



State of West Virginia
 Department of Administration
 Purchasing Division
 2019 Washington Street East
 Post Office Box 50130
 Charleston, WV 25305-0130

Request for Quotation

RFQ NUMBER
858C2046

PAGE
1

ADDRESS CORRESPONDENCE TO ATTENTION OF
**MICHAEL AUSTIN
 304-558-2402**

RFQ COPY
 TYPE NAME/ADDRESS HERE

*COMADE, INC
 17915-D Sky Park Circle
 AD
 IRVING, CA. 92614*

DIVISION OF HIGHWAYS
 VARIOUS LOCALES AS INDICATED
 BY ORDER

DATE PRINTED	TERMS OF SALE	SHIP VIA	FOB	FREIGHT TERMS
06/12/2008				

BID OPENING DATE: **07/02/2008** BID OPENING TIME **01:30PM**

LINE	QUANTITY	UOP	CAT NO	ITEM NUMBER	UNIT PRICE	AMOUNT
0001	1	LS		210-16		
<p>GALVANIZED U-CHANNEL</p> <p>OPEN END CONTRACT</p> <p>TO PROVIDE THE WV DIVISION OF HIGHWAYS MAINTENANCE DIVISION WITH GALVANIZED U-CHANNEL. PER THE ATTACHED SPECIFICATIONS.</p> <p>EXHIBIT 3</p> <p>LIFE OF CONTRACT: THIS CONTRACT BECOMES EFFECTIVE ON AND EXTENDS FOR A PERIOD OF ONE (1) YEAR OR UNTIL SUCH "REASONABLE TIME" THEREAFTER AS IS NECESSARY TO OBTAIN A NEW CONTRACT OR RENEW THE ORIGINAL CONTRACT. THE "REASONABLE TIME" PERIOD SHALL NOT EXCEED TWELVE (12) MONTHS. DURING THIS "REASONABLE TIME" THE VENDOR MAY TERMINATE THIS CONTRACT FOR ANY REASON UPON GIVING THE DIRECTOR OF PURCHASING 30 DAYS WRITTEN NOTICE.</p> <p>UNLESS SPECIFIC PROVISIONS ARE STIPULATED ELSEWHERE IN THIS CONTRACT DOCUMENT, THE TERMS, CONDITIONS AND PRICING SET HEREIN ARE FIRM FOR THE LIFE OF THE CONTRACT.</p> <p>RENEWAL: THIS CONTRACT MAY BE RENEWED UPON THE MUTUAL WRITTEN CONSENT OF THE SPENDING UNIT AND VENDOR, SUBMITTED TO THE DIRECTOR OF PURCHASING THIRTY (30) DAYS PRIOR TO THE EXPIRATION DATE. SUCH RENEWAL SHALL BE IN ACCORDANCE WITH THE TERMS AND CONDITIONS OF THE</p>						

RECEIVED
 2008 JUN 30 A 10:30
 DIVISION OF HIGHWAYS
 STATE OF WV

SEE REVERSE SIDE FOR TERMS AND CONDITIONS

SIGNATURE <i>[Signature]</i>	TELEPHONE 919-474-0160	DATE 6-25-08
TITLE <i>Division Manager</i>	FEIN <i>33-01-771</i>	ADDRESS CHANGES TO BE NOTED ABOVE

WHEN RESPONDING TO RFQ, INSERT NAME AND ADDRESS IN SPACE ABOVE LABELED 'VENDOR'

**GENERAL TERMS & CONDITIONS
REQUEST FOR QUOTATION (RFQ) AND REQUEST FOR PROPOSAL (RFP)**

1. Awards will be made in the best interest of the State of West Virginia.
2. The State may accept or reject in part, or in whole, any bid.
3. All quotations are governed by the *West Virginia Code* and the *Legislative Rules* of the Purchasing Division.
4. Prior to any award, the apparent successful vendor must be properly registered with the Purchasing Division and have paid the required \$125.00 registration fee.
5. All services performed or goods delivered under State Purchase Orders/Contracts are to be continued for the term of the Purchase Order/Contract, contingent upon funds being appropriated by the Legislature or otherwise being made available. In the event funds are not appropriated or otherwise available for these services or goods, this Purchase Order/Contract becomes void and of no effect after June 30.
6. Payment may only be made after the delivery and acceptance of goods or services.
7. Interest may be paid for late payment in accordance with the *West Virginia Code*.
8. Vendor preference will be granted upon written request in accordance with the *West Virginia Code*.
9. The State of West Virginia is exempt from federal and state taxes and will not pay or reimburse such taxes.
10. The Director of Purchasing may cancel any Purchase Order/Contract upon 30 days written notice to the seller.
11. The laws of the State of West Virginia and the *Legislative Rules* of the Purchasing Division shall govern all rights and duties under the Contract, including without limitation the validity of this Purchase Order/Contract.
12. Any reference to automatic renewal is hereby deleted. The Contract may be renewed only upon mutual written agreement of the parties.
13. **BANKRUPTCY:** In the event the vendor/contractor files for bankruptcy protection, this Contract may be deemed null and void, and terminated without further order.
14. **HIPAA Business Associate Addendum** - The West Virginia State Government HIPAA Business Associate Addendum (BAA), approved by the Attorney General, and available online at the Purchasing Division's web site (<http://www.state.wv.us/admin/purchase/vrc/hipaa.htm>) is hereby made part of the agreement. Provided that, the Agency meets the definition of a Covered Entity (45 CFR §160.103) and will be disclosing Protected Health Information (45 CFR §160.103) to the vendor.

INSTRUCTIONS TO BIDDERS

1. Use the quotation forms provided by the Purchasing Division.
2. **SPECIFICATIONS:** Items offered must be in compliance with the specifications. Any deviation from the specifications must be clearly indicated by the bidder. Alternates offered by the bidder as **EQUAL** to the specifications must be clearly defined. A bidder offering an alternate should attach complete specifications and literature to the bid. The Purchasing Division may waive minor deviations to specifications.
3. Complete all sections of the quotation form.
4. Unit prices shall prevail in cases of discrepancy.
5. All quotations are considered F.O.B. destination unless alternate shipping terms are clearly identified in the quotation.
6. **BID SUBMISSION:** All quotations must be delivered by the bidder to the office listed below prior to the date and time of the bid opening. Failure of the bidder to deliver the quotations on time will result in bid disqualifications.

SIGNED BID TO:

Department of Administration
Purchasing Division
2019 Washington Street East
Post Office Box 50130
Charleston, WV 25305-0130



State of West Virginia
 Department of Administration
 Purchasing Division
 2019 Washington Street East
 Post Office Box 50130
 Charleston, WV 25305-0130

Request for Quotation

RFQ NUMBER
858C2046

PAGE
2

ADDRESS CORRESPONDENCE TO ATTENTION OF:
**MICHAEL AUSTIN
 304-558-2402**

RFQ COPY
 TYPE NAME/ADDRESS HERE

VENDOR

*COMADE, INC
 17915-B Sky Park Circle
 Irvine, CA 92614*

SHIP TO

DIVISION OF HIGHWAYS
 VARIOUS LOCALES AS INDICATED
 BY ORDER

DATE PRINTED 06/12/2008	TERMS OF SALE	SHIP VIA	FOB	FREIGHT TERMS
BID OPENING DATE: 07/02/2008		BID OPENING TIME 01:30PM		

LINE	QUANTITY	UOP	CAT NO	ITEM NUMBER	UNIT PRICE	AMOUNT
<p>ORIGINAL CONTRACT AND SHALL BE LIMITED TO TWO (2) ONE (1) YEAR PERIODS.</p> <p>CANCELLATION: THE DIRECTOR OF PURCHASING RESERVES THE RIGHT TO CANCEL THIS CONTRACT IMMEDIATELY UPON WRITTEN NOTICE TO THE VENDOR IF THE COMMODITIES AND/OR SERVICE SUPPLIED ARE OF AN INFERIOR QUALITY OR DO NOT CONFORM TO THE SPECIFICATIONS OF THE BID AND CONTRACT HEREIN.</p> <p>OPEN MARKET CLAUSE: THE DIRECTOR OF PURCHASING MAY AUTHORIZE A SPENDING UNIT TO PURCHASE ON THE OPEN MARKET, WITHOUT THE FILING OF A REQUISITION OR COST ESTIMATE, ITEMS SPECIFIED ON THIS CONTRACT FOR IMMEDIATE DELIVERY IN EMERGENCIES DUE TO UNFORESEEN CAUSES (INCLUDING BUT NOT LIMITED TO DELAYS IN TRANSPORTATION OR AN UNANTICIPATED INCREASE IN THE VOLUME OF WORK.)</p> <p>QUANTITIES: QUANTITIES LISTED IN THE REQUISITION ARE APPROXIMATIONS ONLY, BASED ON ESTIMATES SUPPLIED BY THE STATE SPENDING UNIT. IT IS UNDERSTOOD AND AGREED THAT THE CONTRACT SHALL COVER THE QUANTITIES ACTUALLY ORDERED FOR DELIVERY DURING THE TERM OF THE CONTRACT, WHETHER MORE OR LESS THAN THE QUANTITIES SHOWN.</p> <p>ORDERING PROCEDURE: SPENDING UNIT(S) SHALL ISSUE A WRITTEN STATE CONTRACT ORDER (FORM NUMBER WV-39) TO THE VENDOR FOR COMMODITIES COVERED BY THIS CONTRACT. THE ORIGINAL COPY OF THE WV-39 SHALL BE MAILED TO THE VENDOR AS AUTHORIZATION FOR SHIPMENT, A SECOND COPY MAILED TO THE PURCHASING DIVISION, AND A THIRD COPY RETAINED BY THE SPENDING UNIT.</p> <p>BANKRUPTCY: IN THE EVENT THE VENDOR/CONTRACTOR FILES FOR BANKRUPTCY PROTECTION, THIS CONTRACT IS AUTOMATICALLY NULL AND VOID, AND IS TERMINATED WITHOUT FURTHER</p>						

SEE REVERSE SIDE FOR TERMS AND CONDITIONS

SIGNATURE <i>[Signature]</i>	TELEPHONE 949-474-0160	DATE 6-25-08
TITLE <i>Traffic Division Manager</i>	FEIN 85-101311	ADDRESS CHANGES TO BE NOTED ABOVE

WHEN RESPONDING TO RFQ, INSERT NAME AND ADDRESS IN SPACE ABOVE LABELED 'VENDOR'



State of West Virginia
 Department of Administration
 Purchasing Division
 2019 Washington Street East
 Post Office Box 50130
 Charleston, WV 25305-0130

**Request for
 Quotation**

RFQ NUMBER
858C2046

PAGE
3

ADDRESS CORRESPONDENCE TO ATTENTION OF
**MICHAEL AUSTIN
 304-558-2402**

RFQ COPY
 TYPE NAME/ADDRESS HERE

*AD
 COMABE, INC
 17915-B Sky Park Circle
 Irvine, CA. 92614*

DIVISION OF HIGHWAYS
 VARIOUS LOCALES AS INDICATED
 BY ORDER

DATE PRINTED	TERMS OF SALE	SHIP VIA	F.O.B.	FREIGHT TERMS		
06/12/2008						
BID OPENING DATE: 07/02/2008		BID OPENING TIME 01:30PM				
LINE	QUANTITY	UOP	CAT NO	ITEM NUMBER	UNIT PRICE	AMOUNT
<p>ORDER.</p> <p>THE TERMS AND CONDITIONS CONTAINED IN THIS CONTRACT SHALL SUPERSEDE ANY AND ALL SUBSEQUENT TERMS AND CONDITIONS WHICH MAY APPEAR ON ANY ATTACHED PRINTED DOCUMENTS SUCH AS PRICE LISTS, ORDER FORMS, SALES AGREEMENTS OR MAINTENANCE AGREEMENTS, INCLUDING ANY ELECTRONIC MEDIUM SUCH AS CD-ROM.</p> <p>REV. 04/11/2001</p> <p>PURCHASING CARD ACCEPTANCE: THE STATE OF WEST VIRGINIA CURRENTLY UTILIZES A VISA PURCHASING CARD PROGRAM WHICH IS ISSUED THROUGH A BANK. THE SUCCESSFUL VENDOR MUST ACCEPT THE STATE OF WEST VIRGINIA VISA PURCHASING CARD FOR PAYMENT OF ALL ORDERS PLACED BY ANY STATE AGENCY AS A CONDITION OF AWARD.</p> <p>EXHIBIT 10</p> <p>REQUISITION NO.:</p> <p>ADDENDUM ACKNOWLEDGEMENT</p> <p>I HEREBY ACKNOWLEDGE RECEIPT OF THE FOLLOWING CHECKED ADDENDUM(S) AND HAVE MADE THE NECESSARY REVISIONS TO MY PROPOSAL, PLANS AND/OR SPECIFICATION, ETC.</p> <p>ADDENDUM NO.'S:</p> <p>NO. 1</p> <p>NO. 2</p>						

SEE REVERSE SIDE FOR TERMS AND CONDITIONS

SIGNATURE *[Signature]* TELEPHONE **949-474-0160** DATE **6-25-08**

TITLE *Public Division Manager* FEIN **37-103311** ADDRESS CHANGES TO BE NOTED ABOVE

WHEN RESPONDING TO RFQ, INSERT NAME AND ADDRESS IN SPACE ABOVE LABELED 'VENDOR'



State of West Virginia
 Department of Administration
 Purchasing Division
 2019 Washington Street East
 Post Office Box 50130
 Charleston, WV 25305-0130

**Request for
 Quotation**

RFQ NUMBER
 858C2046

PAGE
 4

ADDRESS CORRESPONDENCE TO ATTENTION OF
 MICHAEL AUSTIN
 304-558-2402

RFQ COPY
 TYPE NAME/ADDRESS HERE

*COMADE, INC
 17915-B Sky Park Circle
 IRVINE, CA. 92614*

DIVISION OF HIGHWAYS
 VARIOUS LOCALES AS INDICATED
 BY ORDER

DATE PRINTED 06/12/2008	TERMS OF SALE	SHIP VIA	F.O.B.	FREIGHT TERMS
----------------------------	---------------	----------	--------	---------------

BID OPENING DATE: 07/02/2008 BID OPENING TIME 01:30PM

LINE	QUANTITY	UOP	CAT NO	ITEM NUMBER	UNIT PRICE	AMOUNT
NO. 3					
NO. 4					
NO. 5					
<p>I UNDERSTAND THAT FAILURE TO CONFIRM THE RECEIPT OF THE ADDENDUM(S) MAY BE CAUSE FOR REJECTION OF BIDS.</p> <p>VENDOR MUST CLEARLY UNDERSTAND THAT ANY VERBAL REPRESENTATION MADE OR ASSUMED TO BE MADE DURING ANY ORAL DISCUSSION HELD BETWEEN VENDOR'S REPRESENTATIVES AND ANY STATE PERSONNEL IS NOT BINDING. ONLY THE INFORMATION ISSUED IN WRITING AND ADDED TO THE SPECIFICATIONS BY AN OFFICIAL ADDENDUM IS BINDING.</p> <p>..... SIGNATURE <i>COMADE, INC</i> COMPANY 6-24-08 DATE</p> <p>REV. 11/96</p> <p>VENDOR PREFERENCE CERTIFICATE</p> <p>CERTIFICATION AND APPLICATION* IS HEREBY MADE FOR PREFERENCE IN ACCORDANCE WITH WEST VIRGINIA CODE, 5A-3-37 (DOES NOT APPLY TO CONSTRUCTION CONTRACTS).</p>						

SEE REVERSE SIDE FOR TERMS AND CONDITIONS

SIGNATURE <i>[Signature]</i>	TELEPHONE 204-474-0160	DATE 6-25-08
TITLE Traffic Division Manager	FEIN 37-1012311	ADDRESS CHANGES TO BE NOTED ABOVE

WHEN RESPONDING TO RFQ, INSERT NAME AND ADDRESS IN SPACE ABOVE LABELED 'VENDOR'



State of West Virginia
 Department of Administration
 Purchasing Division
 2019 Washington Street East
 Post Office Box 50130
 Charleston, WV 25305-0130

**Request for
 Quotation**

RFQ NUMBER
 858C2046

PAGE
 5

ADDRESS CORRESPONDENCE TO ATTENTION OF
 MICHAEL AUSTIN
 304-558-2402

RFQ COPY
 TYPE NAME/ADDRESS HERE

*COMAPE, INC
 17915-B Sky Park Circle
 Irvine, CA 92614*

DIVISION OF HIGHWAYS
 VARIOUS LOCALES AS INDICATED
 BY ORDER

DATE PRINTED	TERMS OF SALE	SHIP VIA	F.O.B.	FREIGHT TERMS
06/12/2008				

BID OPENING DATE: 07/02/2008 BID OPENING TIME 01:30PM

LINE	QUANTITY	UOP	CAT NO	ITEM NUMBER	UNIT PRICE	AMOUNT
<p>A. APPLICATION IS MADE FOR 2.5% PREFERENCE FOR THE REASON CHECKED:</p> <p>() BIDDER IS AN INDIVIDUAL RESIDENT VENDOR AND HAS RESIDED CONTINUOUSLY IN WEST VIRGINIA FOR FOUR (4) YEARS IMMEDIATELY PRECEDING THE DATE OF THIS CERTIFICATION; OR</p> <p>() BIDDER IS A PARTNERSHIP, ASSOCIATION OR CORPORATION RESIDENT VENDOR AND HAS MAINTAINED ITS HEAD-QUARTERS OR PRINCIPAL PLACE OF BUSINESS CONTINUOUSLY IN WEST VIRGINIA FOR FOUR (4) YEARS IMMEDIATELY PRECEDING THE DATE OF THIS CERTIFICATION; OR 80% OF THE OWNERSHIP INTEREST OF BIDDER IS HELD BY ANOTHER INDIVIDUAL, PARTNERSHIP, ASSOCIATION OR CORPORATION RESIDENT VENDOR WHO HAS MAINTAINED ITS HEADQUARTERS OR PRINCIPAL PLACE OF BUSINESS CONTINUOUSLY IN WEST VIRGINIA FOR FOUR (4) YEARS IMMEDIATELY PRECEDING THE DATE OF THIS CERTIFICATION; OR</p> <p>() BIDDER IS A CORPORATION NONRESIDENT VENDOR WHICH HAS AN AFFILIATE OR SUBSIDIARY WHICH EMPLOYS A MINIMUM OF ONE HUNDRED STATE RESIDENTS AND WHICH HAS MAINTAINED ITS HEADQUARTERS OR PRINCIPAL PLACE OF BUSINESS WITHIN WEST VIRGINIA CONTINUOUSLY FOR THE FOUR (4) YEARS IMMEDIATELY PRECEDING THE DATE OF THIS CERTIFICATION.</p> <p>B. APPLICATION IS MADE FOR 2.5% PREFERENCE FOR THE REASON CHECKED:</p> <p>() BIDDER IS A RESIDENT VENDOR WHO CERTIFIES THAT, DURING THE LIFE OF THE CONTRACT, ON AVERAGE AT LEAST 75% OF THE EMPLOYEES WORKING ON THE PROJECT BEING BID ARE RESIDENTS OF WEST VIRGINIA WHO HAVE RESIDED IN</p>						

SEE REVERSE SIDE FOR TERMS AND CONDITIONS

SIGNATURE <i>[Signature]</i>	TELEPHONE 948-474-0160	DATE 6-25-08
TITLE Traffic Division Manager	FEIN 33-10371	ADDRESS CHANGES TO BE NOTED ABOVE

WHEN RESPONDING TO RFQ, INSERT NAME AND ADDRESS IN SPACE ABOVE LABELED 'VENDOR'



State of West Virginia
 Department of Administration
 Purchasing Division
 2019 Washington Street East
 Post Office Box 50130
 Charleston, WV 25305-0130

Request for Quotation

RFQ NUMBER
 858C2046

PAGE
 6

ADDRESS CORRESPONDENCE TO ATTENTION OF
 MICHAEL AUSTIN
 304-558-2402

RFQ COPY

TYPE NAME/ADDRESS HERE

VENDOR

COMADE, INC
 17915-R Sky Park Circle
 Irvine, CA 92614

SHIP TO

DIVISION OF HIGHWAYS
 VARIOUS LOCALES AS INDICATED
 BY ORDER

DATE PRINTED 06/12/2008	TERMS OF SALE	SHIP VIA	F.O.B.	FREIGHT TERMS
BID OPENING DATE: 07/02/2008		BID OPENING TIME 01:30PM		

LINE	QUANTITY	UOP	CAT NO	ITEM NUMBER	UNIT PRICE	AMOUNT
<p>THE STATE CONTINUOUSLY FOR THE TWO YEARS IMMEDIATELY PRECEDING SUBMISSION OF THIS BID; OR () BIDDER IS A NONRESIDENT VENDOR EMPLOYING A MINIMUM OF ONE HUNDRED STATE RESIDENTS OR IS A NONRESIDENT VENDOR WITH AN AFFILIATE OR SUBSIDIARY WHICH MAINTAINS ITS HEADQUARTERS OR PRINCIPAL PLACE OF BUSINESS WITHIN WEST VIRGINIA EMPLOYING A MINIMUM OF ONE HUNDRED STATE RESIDENTS WHO CERTIFIES THAT, DURING THE LIFE OF THE CONTRACT, ON AVERAGE AT LEAST 75% OF THE EMPLOYEES OR BIDDERS' AFFILIATE'S OR SUBSIDIARY'S EMPLOYEES ARE RESIDENTS OF WEST VIRGINIA WHO HAVE RESIDED IN THE STATE CONTINUOUSLY FOR THE TWO YEARS IMMEDIATELY PRECEDING SUBMISSION OF THIS BID.</p> <p>BIDDER UNDERSTANDS IF THE SECRETARY OF TAX & REVENUE DETERMINES THAT A BIDDER RECEIVING PREFERENCE HAS FAILED TO CONTINUE TO MEET THE REQUIREMENTS FOR SUCH PREFERENCE, THE SECRETARY MAY ORDER THE DIRECTOR OF PURCHASING TO: (A) RESCIND THE CONTRACT OR PURCHASE ORDER ISSUED; OR (B) ASSESS A PENALTY AGAINST SUCH BIDDER IN AN AMOUNT NOT TO EXCEED 5% OF THE BID AMOUNT AND THAT SUCH PENALTY WILL BE PAID TO THE CONTRACTING AGENCY OR DEDUCTED FROM ANY UNPAID BALANCE ON THE CONTRACT OR PURCHASE ORDER.</p> <p>BY SUBMISSION OF THIS CERTIFICATE, BIDDER AGREES TO DISCLOSE ANY REASONABLY REQUESTED INFORMATION TO THE PURCHASING DIVISION AND AUTHORIZES THE DEPARTMENT OF TAX AND REVENUE TO DISCLOSE TO THE DIRECTOR OF PURCHASING APPROPRIATE INFORMATION VERIFYING THAT BIDDER HAS PAID THE REQUIRED BUSINESS TAXES, PROVIDED THAT SUCH INFORMATION DOES NOT CONTAIN THE AMOUNTS OF TAXES PAID NOR ANY OTHER INFORMATION DEEMED BY THE TAX COMMISSIONER TO BE CONFIDENTIAL.</p>						

SEE REVERSE SIDE FOR TERMS AND CONDITIONS

SIGNATURE 	TELEPHONE 949-414-0160	DATE 6-21-08
TITLE Traffic Division Manager	FEIN 33-1013311	ADDRESS CHANGES TO BE NOTED ABOVE

WHEN RESPONDING TO RFQ, INSERT NAME AND ADDRESS IN SPACE ABOVE LABELED 'VENDOR'



State of West Virginia
 Department of Administration
 Purchasing Division
 2019 Washington Street East
 Post Office Box 50130
 Charleston, WV 25305-0130

Request for Quotation

RFQ NUMBER
858C2046

PAGE
7

ADDRESS CORRESPONDENCE TO ATTENTION OF
**MICHAEL AUSTIN
 304-558-2402**

REVENUE REPORT

RFQ COPY
 TYPE NAME/ADDRESS HERE

*COMADE, INC
 17915-J Sky Park Circle
 Irvine, CA 92614*

SHIP TO

DIVISION OF HIGHWAYS
 VARIOUS LOCALES AS INDICATED
 BY ORDER

DATE PRINTED	TERMS OF SALE	SHIP VIA	F.O.B.	FREIGHT TERMS
06/12/2008				

BID OPENING DATE: **07/02/2008** BID OPENING TIME **01:30PM**

LINE	QUANTITY	UOP	CAT NO	ITEM NUMBER	UNIT PRICE	AMOUNT
<p>UNDER PENALTY OF LAW FOR FALSE SWEARING (WEST VIRGINIA CODE 61-5-3), BIDDER HEREBY CERTIFIES THAT THIS CERTIFICATE IS TRUE AND ACCURATE IN ALL RESPECTS; AND THAT IF A CONTRACT IS ISSUED TO BIDDER AND IF ANYTHING CONTAINED WITHIN THIS CERTIFICATE CHANGES DURING THE TERM OF THE CONTRACT, BIDDER WILL NOTIFY THE PURCHASING DIVISION IN WRITING IMMEDIATELY.</p> <p>BIDDER: <i>COMADE, INC</i></p> <p>DATE: <i>6-24-08</i></p> <p>SIGNED: <i>[Signature]</i></p> <p>TITLE: <i>Traffic Division Manager</i></p> <p>* CHECK ANY COMBINATION OF PREFERENCE CONSIDERATION(S) IN EITHER "A" OR "B", OR BOTH "A" AND "B" WHICH YOU ARE ENTITLED TO RECEIVE. YOU MAY REQUEST UP TO THE MAXIMUM 5% PREFERENCE FOR BOTH "A" AND "B". (REV. 12/00)</p> <p>NOTICE</p> <p>A SIGNED BID MUST BE SUBMITTED TO:</p> <p>DEPARTMENT OF ADMINISTRATION PURCHASING DIVISION BUILDING 15 2019 WASHINGTON STREET, EAST CHARLESTON, WV 25305-0130</p>						

SEE REVERSE SIDE FOR TERMS AND CONDITIONS			
SIGNATURE <i>[Signature]</i>	TELEPHONE <i>949-474-0160</i>	DATE <i>6-25-08</i>	
TITLE <i>Traffic Division Manager</i>	FEIN <i>33-101371</i>	ADDRESS CHANGES TO BE NOTED ABOVE	

WHEN RESPONDING TO RFQ, INSERT NAME AND ADDRESS IN SPACE ABOVE LABELED 'VENDOR'

SCOPE OF CONTRACT

The purpose of this Contract shall be to supply WVDOH maintenance personnel with galvanized u-channel for standard maintenance.

SPECIFICATIONS FOR ITEMS

Galvanized u-channel supports (Items 1-31): Acceptance of u-channel supports supplied as part of this Contract shall be in accordance with the normal WVDOH acceptance procedures. U-channel posts are to be of a material that meets the requirements of Section 657 of the West Virginia Division of Highways' Standard Specifications For Roads and Bridges, latest edition. U-channel posts shall meet the shape and dimensional requirements shown on Sheet TE1-7A of the WVDOH, Standard Details Book, Volume 2, latest edition. Post lengths shall be as specified with a tolerance of +/- one (1) inch. Galvanized posts are to be galvanized in accordance with ASTM Specification A123. Posts supplied shall be manufactured only by approved manufacturers listed on the Division Approved Products List (APL), and shall be limited on this Contract to posts manufactured by Nucor-Marion Steel and Franklin Steel.

AWARD CONSIDERATIONS IN REGARDS TO EXISTING INVENTORY

The WVDOH reserves the right to award key items on this Contract to two separate vendors for the purpose of maintaining compatibility of items being supplied under the new contract with existing items in inventory.

PRICE ADJUSTMENT CLASUE

The State of West Virginia will consider proposed price adjustments prior to the original expiration date of the Contract, provided that such price adjustment covers both upward and downward movement of the commodity price, and that adjustment is based on the "pass through" increase or decrease of raw materials and/or labor, which make up all or a substantial part of a product. Adjustments are to be based upon an actual dollar figure, not a percentage. All price adjustment requests must be substantiated in a manner acceptable to the Director of the WV Purchasing Division (e.g. governmental bench marks, general market increases, and published price lists). All documentation of price increases incurred by the vendor shall be based on governmental bench marks, general market increases, published price lists, etc. in effect on the original effective date of the Contract, or the effective date of the currently approved price increase in effect, as applicable. Such requests for price increases shall be received in writing by the Director of the Traffic Engineering Division at least 30-days in advance of the proposed effective date of the increase. The price increase request will be evaluated by the Traffic Engineering Division and will be forwarded to the Purchasing Division for concurrence. The vendor may not submit a request for a price increase with a proposed effective date less than 90-days from the original effective date of the Contract. Subsequent requests for price increases may not have a proposed effective date less than 90-days from the effective date of the currently approved price increase in effect. Any time the vendor requests a price adjustment, the Purchasing Division may either accept the price adjustment and amend the Contract accordingly or reject the adjustment and cancel the Contract.

MINIMUM ORDERS

When ordering Items listed on lines 1 through 31, the total combined material ordered, based on these Item numbers, shall be a minimum of 24,000 lbs.

DELIVERY

The supplier shall be allowed sixty (60) calendar days A.R.O. for delivery. The WVDOH shall assess liquidating damages against the supplier for each day that any delivery of material is delayed beyond the sixty (60) day limit. The District may waive a portion or all of the late delivery charges at their discretion provided an ample supply of material is in stock at the District.

The total amount of the liquidating damages shall be \$490 per day, per order, and is in accordance with Section 108.7 of the West Virginia Standard Specifications, Roads and Bridges.

The vendor must notify the receiving District a minimum of 72 hours (3 working days) prior to delivery.

BID SCHEDULE

The following estimated quantities are for bid purposes only. Actual quantities will be determined by needs of the West Virginia Division of Highways and may be increased or decreased.

Item Number	Estimated Quantity	Description	Unit Cost <i>AD</i>	Amount	Inventory Class / Type / Subcode (DOH Use Only)
1	700	Galvanized U-Channel, 2 # per foot, 4 foot long	9.28	\$ 6,496.00	019 014 200004
2	10	Galvanized U-Channel, 2 # per foot, 5 foot long	11.60	\$ 116.00	019 014 200005
3	300	Galvanized U-Channel, 2 # per foot, 6 foot long	13.56	\$ 4,068.00	019 014 200006
4	1100	Galvanized U-Channel, 2 # per foot, 7 foot long	15.82	\$ 17,402.00	019 014 200007
5	2000	Galvanized U-Channel, 2 # per foot, 8 foot long	18.08	\$ 36,160.00	019 014 200008
6	10	Galvanized U-Channel, 2 # per foot, 9 foot long	20.34	\$ 203.40	019 014 200009
7	2000	Galvanized U-Channel, 2 # per foot, 10 foot long	22.60	\$ 45,200.00	019 014 200010
8	10	Galvanized U-Channel, 2 # per foot, 11 foot long	24.86	\$ 248.60	019 014 200011
9	10	Galvanized U-Channel, 2 # per foot, 12 foot long	27.12	\$ 271.20	019 014 200012
10	10	Galvanized U-Channel, 2 # per foot, 20 foot long	45.20	\$ 452.00	019 014 200020
11	6100	Galvanized U-Channel, 3 # per foot, 4 foot long	13.52	\$ 82,472.00	019 014 300004
12	10	Galvanized U-Channel, 3 # per foot, 5-1/2 foot long	18.59	\$ 185.90	019 014 300055
13	10	Galvanized U-Channel, 3 # per foot, 6 foot long	19.68 <i>AD</i>	\$ 196.80	019 014 300006
14	500	Galvanized U-Channel, 3 # per foot, 7 foot long	22.96	\$ 11,480.00	019 014 300007
15	10	Galvanized U-Channel, 3 # per foot, 8 foot long	26.24	\$ 262.40	019 014 300008
16	1900	Galvanized U-Channel, 3 # per foot, 9 foot long	29.52	\$ 56,088.00	019 014 300009
17	2700	Galvanized U-Channel, 3 # per foot, 10 foot long	32.80	\$ 88,560.00	019 014 300010
18	800	Galvanized U-Channel, 3 # per foot, 11 foot long	36.08	\$ 28,864.00	019 014 300011
19	700	Galvanized U-Channel, 3 # per foot, 12 foot long	39.36	\$ 27,552.00	019 014 300012
20	10	Galvanized U-Channel, 3 # per foot, 13 foot long	42.64	\$ 426.40	019 014 300013
21	10	Galvanized U-Channel, 3 # per foot, 14 foot long	45.92	\$ 459.20	019 014 300014
22	10	Galvanized U-Channel, 3 # per foot, 16 foot long	52.48	\$ 524.80	019 014 300016
23	10	Galvanized U-Channel, 3 # per foot, 18 foot long	59.04	\$ 590.40	019 014 300018
24	10	Galvanized U-Channel, 3 # per foot, 20 foot long	65.60	\$ 656.00	019 014 300020
25**	10	Galvanized U-Channel, 4 # per foot, 4 foot long	19.52	\$ 195.20	019 014 400004
26**	10	Galvanized U-Channel, 4 # per foot, 6 foot long	28.50	\$ 285.00	019 014 400006
27**	10	Galvanized U-Channel, 4 # per foot, 12 foot long	57.00	\$ 570.00	019 014 400012
28**	10	Galvanized U-Channel, 4 # per foot, 14 foot long	66.50	\$ 665.00	019 014 400014
29**	10	Galvanized U-Channel, 4 # per foot, 16 foot long	76.00	\$ 760.00	019 014 400016
30**	10	Galvanized U-Channel, 4 # per foot, 18 foot long	85.50	\$ 855.00	019 014 400018
31**	10	Galvanized U-Channel, 4 # per foot, 20 foot long	95.00	\$ 950.00	019 014 400020
TOTAL				\$ 413,182.50	

Total combined wt. of these items must be 24,000# min.

** 4# per foot u-channel, 4# back to back u-channel, and 6# back to back u-channel supports, without an approved slip base or breakaway ground connection, are allowed to be installed only where the speed limit is 35 MPH or less, behind guardrail, or outside the "clear zone" as defined in the AASHTO Roadside Design Guide. Also, when using 3 or more 2# or 3# u-channel posts for an assembly, post spacing must be greater than 3-1/2 ft., unless a manufacturer supplied breakaway splice connection is used.

**CONTACT PERSON AND DELIVERY ADDRESS FOR EACH
DIVISION OF HIGHWAYS DESTINATION**

Delivery Address	Contact	Phone Number
WVDOH - D1 Sign Shop 75 Pickens Rd. Nitro, WV 25143	Jim Russell	304-759-0708 304-558-3001*
WVDOH - D2 Sign Shop 801 Madison Ave. Huntington, WV 25704	Tim Mills	304-528-5679 304-528-5600*
WVDOH - D3 Sign Shop 720 Depot St. Parkersburg, WV 26101	Tom Potts	304-420-4815 304-420-4645*
WVDOH - D4 Sign Shop US-19 - 1 mile N. of Clarksburg (gore yard) Clarksburg, WV 26301	Rick Reed	304-627-2401 304-842-1500*
WVDOH - D5 Sign Shop US-50 - 14 miles E. of Keyser Burlington, WV 26710	Doug Placka	304-289-3521 304-289-3521*
WVDOH - D6 Sign Shop US-40 - E. of Wheeling (Middle Creek Rd. 39) Triadelphia, WV 26059	Jim Wurtzbacher	304-238-1205 304-238-4008*
WVDOH - D7 Sign Shop US-33 - 1/2 mile E. of Weston Weston, WV 26452	Tyrone Campbell	304-269-0460 304-269-0414*
WVDOH - D8 Sign Shop Rt. 219 - 1 mile N. of Elkins Elkins, WV 26241	Mike Westfall	304-637-0215 304-637-0220*
WVDOH - D9 Sign Shop US-219 - 1-1/2 miles N. of Lewisburg Country Club Rd. - Brush Rd. Lewisburg, WV 24901	Harry Honaker	304-647-7551 304-647-7450*
WVDOH - D10 Sign Shop 270 Hardwood Lane Princeton, WV 24740	Curtis Whitlow	304-487-5283 304-487-5228*
WVDOH - Traffic Services Complex 180 Dry Branch Rd. Charleston, WV 25306	Chuck Swigger Ted Whitmore	304-558-6356 304-558-9468

* District/Division headquarters phone number

STATE OF WEST VIRGINIA
Purchasing Division**PURCHASING AFFIDAVIT**

West Virginia Code §5A-3-10a states: No contract or renewal of any contract may be awarded by the state or any of its political subdivisions to any vendor or prospective vendor when the vendor or prospective vendor or a related party to the vendor or prospective vendor is a debtor and the debt owed is an amount greater than one thousand dollars in the aggregate

DEFINITIONS:

"Debt" means any assessment, premium, penalty, fine, tax or other amount of money owed to the state or any of its political subdivisions because of a judgment, fine, permit violation, license assessment, defaulted workers' compensation premium, penalty or other assessment presently delinquent or due and required to be paid to the state or any of its political subdivisions, including any interest or additional penalties accrued thereon.

"Debtor" means any individual, corporation, partnership, association, limited liability company or any other form or business association owing a debt to the state or any of its political subdivisions. "Political subdivision" means any county commission; municipality; county board of education; any instrumentality established by a county or municipality; any separate corporation or instrumentality established by one or more counties or municipalities, as permitted by law; or any public body charged by law with the performance of a government function or whose jurisdiction is coextensive with one or more counties or municipalities. "Related party" means a party, whether an individual, corporation, partnership, association, limited liability company or any other form or business association or other entity whatsoever, related to any vendor by blood, marriage, ownership or contract through which the party has a relationship of ownership or other interest with the vendor so that the party will actually or by effect receive or control a portion of the benefit, profit or other consideration from performance of a vendor contract with the party receiving an amount that meets or exceeds five percent of the total contract amount.

EXCEPTION: The prohibition of this section does not apply where a vendor has contested any tax administered pursuant to chapter eleven of this code, workers' compensation premium, permit fee or environmental fee or assessment and the matter has not become final or where the vendor has entered into a payment plan or agreement and the vendor is not in default of any of the provisions of such plan or agreement.

LICENSING: Vendors must be licensed and in good standing in accordance with any and all state and local laws and requirements by any state or local agency of West Virginia, including, but not limited to, the West Virginia Secretary of State's Office, the West Virginia Tax Department, West Virginia Insurance Commission, or any other state agencies or political subdivision. Furthermore, the vendor must provide all necessary releases to obtain information to enable the Director or spending unit to verify that the vendor is licensed and in good standing with the above entities.

CONFIDENTIALITY: The vendor agrees that he or she will not disclose to anyone, directly or indirectly, any such personally identifiable information or other confidential information gained from the agency, unless the individual who is the subject of the information consents to the disclosure in writing or the disclosure is made pursuant to the agency's policies, procedures and rules. Vendors should visit www.state.wv.us/admin/purchase/privacy for the Notice of Agency Confidentiality Policies.

Under penalty of law for false swearing (West Virginia Code, §61-5-3), it is hereby certified that the vendor acknowledges the information in this said affidavit and are in compliance with the requirements as stated.

Vendor's Name: COMADE INC

Authorized Signature:  Date: 6-24-08

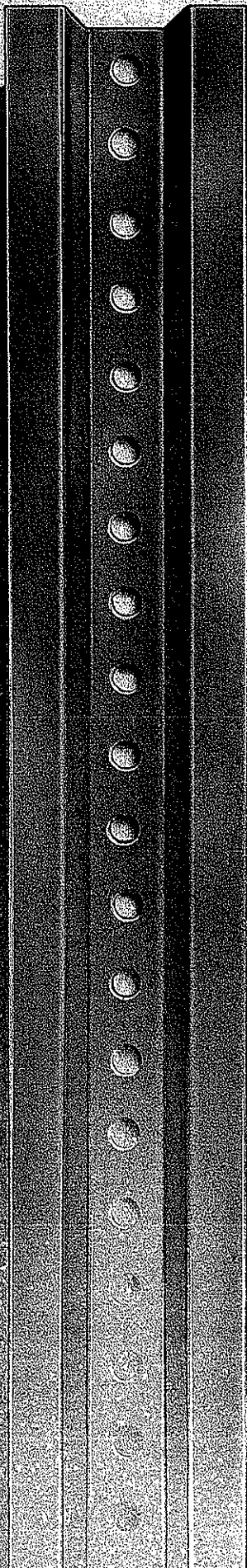

Sign Up With The Specialists



**Chicago
Heights
Steel**

Steel Sign Posts

The sign of a specialist is a quality product. Our sign posts are rolled from superior rail steel—the steel that runs the railroads. For strength—from steel that supports the great weight of trains. For resiliency—from steel that makes a smooth ride by flexing without permanently bending. Posts combining durability and flexibility to stand above the competition.

Sign up with the specialists, and you'll find quality in every aspect of our steel sign posts—from production to delivery.

- **Steel** produced from hot-rolled rail steel 91 lbs./yard and above. Certified to ASTM A-499 Grade 60. 60,000 psi minimum yield strength/ 90,000 psi minimum tensile strength.
- **Punch holes** 3/8" diameter, on 1" centers, starting 1" from the top of post. Custom punching, tapering, various hole sizes, and welded anchor plates also available.
- **Finishes** baked-on green enamel, powder coat, or galvanized to ASTM specification 123, after fabrication is completed. Special colors available.
- **Weights:** 1.12, 2, 2.5, 3, and 4 lbs., with other weights available. Weights of 2 lbs. and above posts plus or minus 5% before punching.
- **Lengths:** 5-14 feet, with length tolerance of plus or minus 1". Custom lengths available.
- **Packaging:** 50-piece nested bundles. Custom packaging upon request.

COMADE, INC.
17915 SKY PARK CIRCLE # B
IRVINE, CA, 92614
949-474-0160

Watts: 1-800-424-4487
Local: 708-756-5662

MEMBER



Superior Strength and Finish

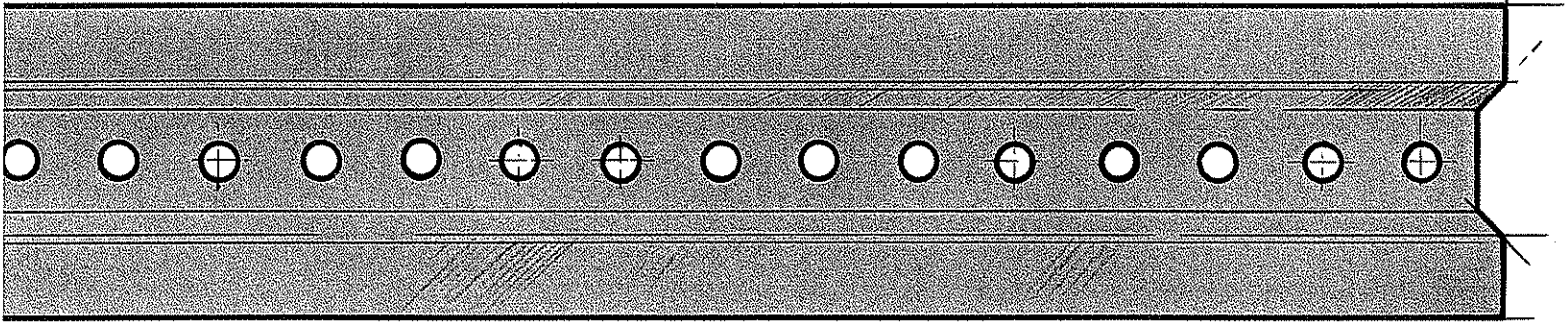

1.12

C-120

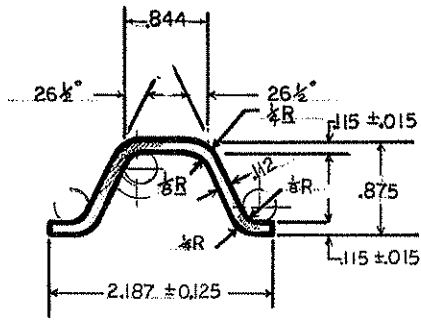

2.50

C-127

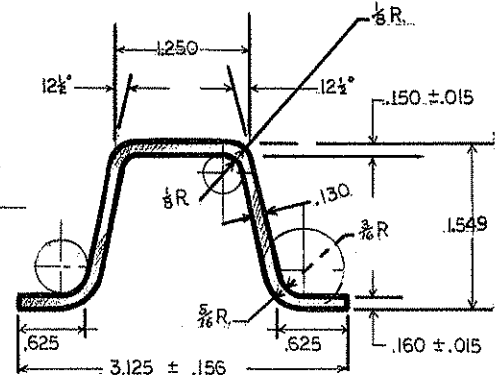

2.00

C-128

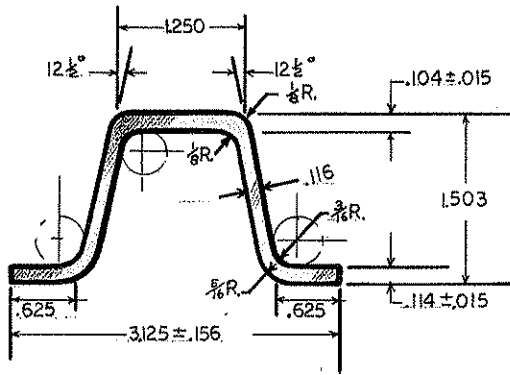

3.00

C-129

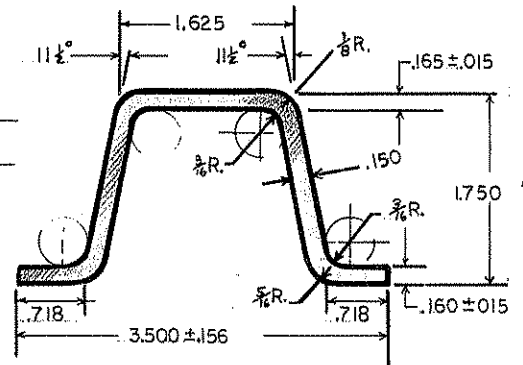

4.00

C-134

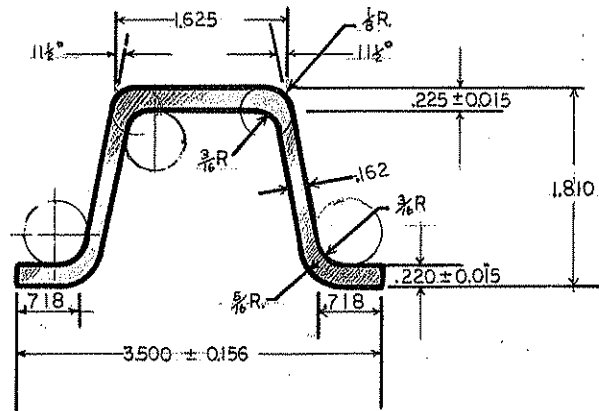

HSI

HIGHWAY STEEL, INC.

211 E. MAIN P.O. BOX 129 CHICAGO HEIGHTS, IL 60411
 708-756-5619 1-800-424-4487
 FAX 708-756-5628

Comade, Inc.

A Commerce Trading Company

17915 Sky Park Circle, Suite B
Irvine, CA 92614

Tel 949 474 0160

Fax 949 474 0161

Email sales@comade.com

Web Page www.comade.com

June 18, 2008

CORPORATE RESOLUTION

At the June 13, 2008 meeting of Directors of Comade, Incorporated, a quorum being there present, on motion duly made and seconded it was resolved:

Chris Schaller, President of Comade, Inc., acting on behalf of the company appoint the persons and positions identified below as having the authority to bind Comade, Inc. in the execution of documents of bids, contracts, and solicitations, and to receive and receipt therefore all purchase orders and notices issues pursuant to the provisions of any such bid or contract, this corporation hereby ratifying approving, confirming, and accepting each and every such act performed by said agent acting on behalf of the company.

Maureen Conway, Marketing Manager

Brandy Sara, Project Manager

Jeff Hebenstreit, Project Manager

Al Berger, Project Manager

Brad Drage, Project Manager

I hereby certify the foregoing to be a true and correct copy of an excerpt of the minutes of the above dated meeting of the Board of Directors of Comade Inc., and the same has not been revoked or rescinded.

Chris Schaller
Secretary-Treasurer