



State of West Virginia
 Department of Administration
 Purchasing Division
 2019 Washington Street East
 Post Office Box 50130
 Charleston, WV 25305-0130

Request for Quotation

RFQ NUMBER
77900045

PAGE
1

ADDRESS CORRESPONDENCE TO ATTENTION OF
MICHAEL AUSTIN
304-558-2402

VENDOR

*709052353 304-562-3538
BLUE RIDGE MACHINERY & TOOLS I
PO BOX 536
2905 PUTNAM AVE
HURRICANE WV 25526

SHIP TO

DIVISION OF HIGHWAYS
CONTRACT ADMINISTRATION DIV
MATERIALS TESTING SECTION
312 MICHIGAN AVENUE
CHARLESTON, WV
25311

DATE PRINTED	TERMS OF SALE	SHIP VIA	F.O.B.	FREIGHT TERMS
03/11/2009				

BID OPENING DATE: **03/25/2009** BID OPENING TIME **01:30PM**

LINE	QUANTITY	UOP	CAT NO	ITEM NUMBER	UNIT PRICE	AMOUNT
0001	1	EA		545-84	23440.00	23440.00
<p>HYDRAULIC SHEAR</p> <p>TO PROVIDE MODEL NO. NH4825 48" HYDRAULIC SHEAR OR EQUAL WITH MODEL NO. NBG48 FRONT OPERATED DIGITAL BACK GAUGE AND MODEL NO. NSA48 SQUARING ARM PER THE ATTACHED SPECIFICATIONS.</p> <p>THE MODEL/BRAND/SPECIFICATIONS NAMED HEREIN ESTABLISH THE ACCEPTABLE LEVEL OF QUALITY ONLY AND ARE NOT INTENDED TO REFLECT A PREFERENCE OR FAVOR ANY PARTICULAR BRAND OR VENDOR. VENDORS WHO ARE BIDDING ALTERNATES SHOULD SO STATE AND INCLUDE PERTINENT LITERATURE AND SPECIFICATIONS. FAILURE TO PROVIDE INFORMATION FOR ANY ALTERNATES MAY BE GROUNDS FOR REJECTION OF THE BID. THE STATE RESERVES THE RIGHT TO WAIVE MINOR IRREGULARITIES IN BIDS OR SPECIFICATIONS IN ACCORDANCE WITH SECTION 148-1-4(F) OF THE WEST VIRGINIA LEGISLATIVE RULES AND REGULATIONS.</p> <p>EXHIBIT 10</p> <p>REQUISITION NO.:</p> <p>ADDENDUM ACKNOWLEDGEMENT</p> <p>I HEREBY ACKNOWLEDGE RECEIPT OF THE FOLLOWING CHECKED ADDENDUM(S) AND HAVE MADE THE NECESSARY REVISIONS TO MY PROPOSAL, PLANS AND/OR SPECIFICATION, ETC.</p> <p>ADDENDUM NO.'S:</p>						

RECEIVED
2009 MAR 19 AM 9:55
WV PURCHASING DIVISION

SEE REVERSE SIDE FOR TERMS AND CONDITIONS			
SIGNATURE 	TELEPHONE 304-562-3538	DATE 03/18/2009	
TITLE Sales Manager	FAX 55-063-0945	ADDRESS CHANGES TO BE NOTED ABOVE	

WHEN RESPONDING TO RFQ, INSERT NAME AND ADDRESS IN SPACE ABOVE LABELED 'VENDOR'

**GENERAL TERMS & CONDITIONS
REQUEST FOR QUOTATION (RFQ) AND REQUEST FOR PROPOSAL (RFP)**

1. Awards will be made in the best interest of the State of West Virginia.
2. The State may accept or reject in part, or in whole, any bid.
3. All quotations are governed by the *West Virginia Code* and the *Legislative Rules* of the Purchasing Division.
4. Prior to any award, the apparent successful vendor must be properly registered with the Purchasing Division and have paid the required \$125 fee.
5. All services performed or goods delivered under State Purchase Order/Contracts are to be continued for the term of the Purchase Order/Contracts, contingent upon funds being appropriated by the Legislature or otherwise being made available. In the event funds are not appropriated or otherwise available for these services or goods, this Purchase Order/Contract becomes void and of no effect after June 30.
6. Payment may only be made after the delivery and acceptance of goods or services.
7. Interest may be paid for late payment in accordance with the *West Virginia Code*.
8. Vendor preference will be granted upon written request in accordance with the *West Virginia Code*.
9. The State of West Virginia is exempt from federal and state taxes and will not pay or reimburse such taxes.
10. The Director of Purchasing may cancel any Purchase Order/Contract upon 30 days written notice to the seller.
11. The laws of the State of West Virginia and the *Legislative Rules* of the Purchasing Division shall govern all rights and duties under the Contract, including without limitation the validity of this Purchase Order/Contract.
12. Any reference to automatic renewal is hereby deleted. The Contract may be renewed only upon mutual written agreement of the parties.
13. **BANKRUPTCY:** In the event the vendor/contractor files for bankruptcy protection, this Contract may be deemed null and void, and terminated without further order.
14. **HIPAA BUSINESS ASSOCIATE ADDENDUM:** The West Virginia State Government HIPAA Business Associate Addendum (BAA), approved by the Attorney General, and available online at the Purchasing Division's web site (<http://www.state.wv.us/admin/purchase/vrc/hipaa.htm>) is hereby made part of the agreement. Provided that, the Agency meets the definition of a Cover Entity (45 CFR §160.103) and will be disclosing Protected Health Information (45 CFR §160.103) to the vendor.
15. **WEST VIRGINIA ALCOHOL & DRUG-FREE WORKPLACE ACT:** If this Contract constitutes a public improvement construction contract as set forth in Article 1D, Chapter 21 of the West Virginia Code ("The West Virginia Alcohol and Drug-Free Workplace Act"), then the following language shall hereby become part of this Contract: "The contractor and its subcontractors shall implement and maintain a written drug-free workplace policy in compliance with the West Virginia Alcohol and Drug-Free Workplace Act, as set forth in Article 1D, Chapter 21 of the West Virginia Code. The contractor and its subcontractors shall provide a sworn statement in writing, under the penalties of perjury, that they maintain a valid drug-free work place policy in compliance with the West Virginia and Drug-Free Workplace Act. It is understood and agreed that this Contract shall be cancelled by the awarding authority if the Contractor: 1) Fails to implement its drug-free workplace policy; 2) Fails to provide information regarding implementation of the contractor's drug-free workplace policy at the request of the public authority; or 3) Provides to the public authority false information regarding the contractor's drug-free workplace policy."

INSTRUCTIONS TO BIDDERS

1. Use the quotation forms provided by the Purchasing Division.
2. **SPECIFICATIONS:** Items offered must be in compliance with the specifications. Any deviation from the specifications must be clearly indicated by the bidder. Alternates offered by the bidder as **EQUAL** to the specifications must be clearly defined. A bidder offering an alternate should attach complete specifications and literature to the bid. The Purchasing Division may waive minor deviations to specifications.
3. Complete all sections of the quotation form.
4. Unit prices shall prevail in case of discrepancy.
5. All quotations are considered F.O.B. destination unless alternate shipping terms are clearly identified in the quotation.
6. **BID SUBMISSION:** All quotations must be delivered by the bidder to the office listed below prior to the date and time of the bid opening. Failure of the bidder to deliver the quotations on time will result in bid disqualifications: Department of Administration, Purchasing Division, 2019 Washington Street East, P.O. Box 50130, Charleston, WV 25305-0130



State of West Virginia
 Department of Administration
 Purchasing Division
 2019 Washington Street East
 Post Office Box 50130
 Charleston, WV 25305-0130

Request for Quotation

RFQ NUMBER
 77900045

PAGE
 2

ADDRESS CORRESPONDENCE TO ATTENTION OF
 MICHAEL AUSTIN
 304-558-2402

VENDOR

*709052353 304-562-3538
 BLUE RIDGE MACHINERY & TOOLS I
 PO BOX 536
 2905 PUTNAM AVE
 HURRICANE WV 25526

SHIP TO

DIVISION OF HIGHWAYS
 CONTRACT ADMINISTRATION DIV
 MATERIALS TESTING SECTION
 312 MICHIGAN AVENUE
 CHARLESTON, WV
 25311

DATE PRINTED	TERMS OF SALE	SHIP VIA	FOB	FREIGHT TERMS
03/11/2009				

BID OPENING DATE: 03/25/2009 BID OPENING TIME 01:30PM

LINE	QUANTITY	UOP	CAT NO	ITEM NUMBER	UNIT PRICE	AMOUNT
NO. 1					
NO. 2					
NO. 3					
NO. 4					
NO. 5					
<p>I UNDERSTAND THAT FAILURE TO CONFIRM THE RECEIPT OF TH ADDENDUM(S) MAY BE CAUSE FOR REJECTION OF BIDS.</p> <p>VENDOR MUST CLEARLY UNDERSTAND THAT ANY VERBAL REPRESENTATION MADE OR ASSUMED TO BE MADE DURING ANY ORAL DISCUSSION HELD BETWEEN VENDOR'S REPRESENTATIVES AND ANY STATE PERSONNEL IS NOT BINDING. ONLY THE INFORMATION ISSUED IN WRITING AND ADDED TO THE SPECIFICATIONS BY AN OFFICIAL ADDENDUM IS BINDING.</p> <p style="text-align: center;">..... SIGNATURE</p> <p style="text-align: center;">Blue Ridge Machinery & Tools, Inc. COMPANY</p> <p style="text-align: center;">03/18/2009 DATE</p> <p>REV. 11/96</p> <p style="text-align: center;">NOTICE</p>						

SEE REVERSE SIDE FOR TERMS AND CONDITIONS

SIGNATURE	TELEPHONE	DATE
TITLE	FEIN	ADDRESS CHANGES TO BE NOTED ABOVE

WHEN RESPONDING TO RFQ, INSERT NAME AND ADDRESS IN SPACE ABOVE LABELED 'VENDOR'



State of West Virginia
 Department of Administration
 Purchasing Division
 2019 Washington Street East
 Post Office Box 50130
 Charleston, WV 25305-0130

Request for Quotation

RFQ NUMBER
 77900045

PAGE
 3

ADDRESS CORRESPONDENCE TO ATTENTION OF
 MICHAEL AUSTIN
 304-558-2402

VENDOR

*709052353 304-562-3538
 BLUE RIDGE MACHINERY & TOOLS I
 PO BOX 536
 2905 PUTNAM AVE
 HURRICANE WV 25526

SHIP TO

DIVISION OF HIGHWAYS
 CONTRACT ADMINISTRATION DIV
 MATERIALS TESTING SECTION
 312 MICHIGAN AVENUE
 CHARLESTON, WV
 25311

DATE PRINTED	TERMS OF SALE	SHIP VIA	F.O.B.	FREIGHT TERMS
03/11/2009				

BID OPENING DATE: 03/25/2009 BID OPENING TIME 01:30PM

LINE	QUANTITY	UOP	CAT. NO.	ITEM NUMBER	UNIT PRICE	AMOUNT
<p>A SIGNED BID MUST BE SUBMITTED TO:</p> <p>DEPARTMENT OF ADMINISTRATION PURCHASING DIVISION BUILDING 15 2019 WASHINGTON STREET, EAST CHARLESTON, WV 25305-0130</p> <p>THE BID SHOULD CONTAIN THIS INFORMATION ON THE FACE OF THE ENVELOPE OR THE BID MAY NOT BE CONSIDERED:</p> <p>SEALED BID</p> <p>BUYER:-----</p> <p>RFQ. NO.:-----</p> <p>BID OPENING DATE:-----</p> <p>BID OPENING TIME:-----</p> <p>PLEASE PROVIDE A FAX NUMBER IN CASE IT IS NECESSARY TO CONTACT YOU REGARDING YOUR BID:</p> <p>-----304-562-5311-----</p> <p>CONTACT PERSON (PLEASE PRINT CLEARLY):</p> <p>-----Charles Keeney-----</p>						

SEE REVERSE SIDE FOR TERMS AND CONDITIONS

SIGNATURE	TELEPHONE	DATE
TITLE	FEIN	ADDRESS CHANGES TO BE NOTED ABOVE

WHEN RESPONDING TO RFQ, INSERT NAME AND ADDRESS IN SPACE ABOVE LABELED 'VENDOR'



State of West Virginia
 Department of Administration
 Purchasing Division
 2019 Washington Street East
 Post Office Box 50130
 Charleston, WV 25305-0130

Request for Quotation

RFQ NUMBER
77900045

PAGE
4

ADDRESS CORRESPONDENCE TO ATTENTION OF
**MICHAEL AUSTIN
 304-558-2402**

VENDOR

*709052353 304-562-3538
**BLUE RIDGE MACHINERY & TOOLS I
 PO BOX 536
 2905 PUTNAM AVE
 HURRICANE WV 25526**

SHIP TO

**DIVISION OF HIGHWAYS
 CONTRACT ADMINISTRATION DIV
 MATERIALS TESTING SECTION
 312 MICHIGAN AVENUE
 CHARLESTON, WV
 25311**

DATE PRINTED	TERMS OF SALE	SHIP VIA	F.O.B.	FREIGHT TERMS
03/11/2009				

BID OPENING DATE: **03/25/2009** BID OPENING TIME **01:30PM**

LINE	QUANTITY	UOP	CAT. NO.	ITEM NUMBER	UNIT PRICE	AMOUNT
***** THIS IS THE END OF RFQ 77900045 ***** TOTAL:						23440.00

SEE REVERSE SIDE FOR TERMS AND CONDITIONS

SIGNATURE	TELEPHONE	DATE
TITLE	FEIN	ADDRESS CHANGES TO BE NOTED ABOVE

WHEN RESPONDING TO RFQ, INSERT NAME AND ADDRESS IN SPACE ABOVE LABELED 'VENDOR'

SPECIFICATION FOR 48" HYDRAULIC SHEAR

1. Model No. NH4825 48" Hydraulic Shear **or Equal**
2. Capacity – ¼"/6.4mm mild steel, 1/8"/3.2 mm stainless steel
3. Strokes Per Minute – Approx. 20
4. Cutting Length 48"
5. Approximate Floor Space w/Gauges 66 ½" x 98" x 54"/1689 x 2489 x 1372mm
6. Oil reservoir capacity 24 gal/91 liters
7. Motor – 7 ½ h.p.
8. Cutting Cap ¼"
9. High carbon, high chromium blades w/4 cutting edges of premium tool steel
10. Equipped with a fully integrated hydraulic unit, conforms to JIC
11. Complete with electrical hydraulic valve
12. Hydraulic rubber inserted hold downs
13. Foot switch allows unit to return to top of stroke when operator removes foot from switch
14. Heavy duty double acting cylinders
15. Fully enclosed control panel
16. Actuated by portable shrouded electric foot switch attached to a long flexible cable for easy operator positioning
17. Quick adjusting hand wheel back gauge for direct reading with a positive lock
18. Low profile shear with under drive construction with downward cylinders and major hydraulics under the bed.
19. 3 Year Warranty.

VENDOR PREFERENCE CERTIFICATE

Certification and application* is hereby made for Preference in accordance with *West Virginia Code*, §5A-3-37. (Does not apply to construction contracts). *West Virginia Code*, §5A-3-37, provides an opportunity for qualifying vendors to request (at the time of bid) preference for their residency status. Such preference is an evaluation method only and will be applied only to the cost bid in accordance with the *West Virginia Code*. This certificate for application is to be used to request such preference. The Purchasing Division will make the determination of the Resident Vendor Preference, if applicable.

1. **Application is made for 2.5% resident vendor preference for the reason checked:**
 Bidder is an individual resident vendor and has resided continuously in West Virginia for four (4) years immediately preceding the date of this certification; or,
 Bidder is a partnership, association or corporation resident vendor and has maintained its headquarters or principal place of business continuously in West Virginia for four (4) years immediately preceding the date of this certification; or 80% of the ownership interest of Bidder is held by another individual, partnership, association or corporation resident vendor who has maintained its headquarters or principal place of business continuously in West Virginia for four (4) years immediately preceding the date of this certification; or,
 Bidder is a nonresident vendor which has an affiliate or subsidiary which employs a minimum of one hundred state residents and which has maintained its headquarters or principal place of business within West Virginia continuously for the four (4) years immediately preceding the date of this certification; or,
2. **Application is made for 2.5% resident vendor preference for the reason checked:**
 Bidder is a resident vendor who certifies that, during the life of the contract, on average at least 75% of the employees working on the project being bid are residents of West Virginia who have resided in the state continuously for the two years immediately preceding submission of this bid; or,
3. **Application is made for 2.5% resident vendor preference for the reason checked:**
 Bidder is a nonresident vendor employing a minimum of one hundred state residents or is a nonresident vendor with an affiliate or subsidiary which maintains its headquarters or principal place of business within West Virginia employing a minimum of one hundred state residents who certifies that, during the life of the contract, on average at least 75% of the employees or Bidder's affiliate's or subsidiary's employees are residents of West Virginia who have resided in the state continuously for the two years immediately preceding submission of this bid; or,
4. **Application is made for 5% resident vendor preference for the reason checked:**
 Bidder meets either the requirement of both subdivisions (1) and (2) or subdivision (1) and (3) as stated above; or,
5. **Application is made for 3.5% resident vendor preference who is a veteran for the reason checked:**
 Bidder is an individual resident vendor who is a veteran of the United States armed forces, the reserves or the National Guard and has resided in West Virginia continuously for the four years immediately preceding the date on which the bid is submitted; or,
6. **Application is made for 3.5% resident vendor preference who is a veteran for the reason checked:**
 Bidder is a resident vendor who is a veteran of the United States armed forces, the reserves or the National Guard, if, for purposes of producing or distributing the commodities or completing the project which is the subject of the vendor's bid and continuously over the entire term of the project, on average at least seventy-five percent of the vendor's employees are residents of West Virginia who have resided in the state continuously for the two immediately preceding years.

Bidder understands if the Secretary of Revenue determines that a Bidder receiving preference has failed to continue to meet the requirements for such preference, the Secretary may order the Director of Purchasing to: (a) reject the bid; or (b) assess a penalty against such Bidder in an amount not to exceed 5% of the bid amount and that such penalty will be paid to the contracting agency or deducted from any unpaid balance on the contract or purchase order.

By submission of this certificate, Bidder agrees to disclose any reasonably requested information to the Purchasing Division and authorizes the Department of Revenue to disclose to the Director of Purchasing appropriate information verifying that Bidder has paid the required business taxes, provided that such information does not contain the amounts of taxes paid nor any other information deemed by the Tax Commissioner to be confidential.

Under penalty of law for false swearing (*West Virginia Code*, §61-5-3), Bidder hereby certifies that this certificate is true and accurate in all respects; and that if a contract is issued to Bidder and if anything contained within this certificate changes during the term of the contract, Bidder will notify the Purchasing Division in writing immediately.

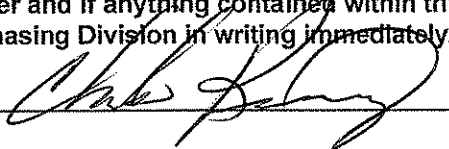
Bidder: Blue Ridge Machinery & Tools, Inc Signed: 

Date: 03/18/2009 Title: Sales Manager

*Check any combination of preference consideration(s) indicated above, which you are entitled to receive.

STATE OF WEST VIRGINIA
Purchasing Division**PURCHASING AFFIDAVIT****VENDOR OWING A DEBT TO THE STATE:**

West Virginia Code §5A-3-10a provides that: No contract or renewal of any contract may be awarded by the state or any of its political subdivisions to any vendor or prospective vendor when the vendor or prospective vendor or a related party to the vendor or prospective vendor is a debtor and the debt owed is an amount greater than one thousand dollars in the aggregate.

PUBLIC IMPROVEMENT CONTRACTS & DRUG-FREE WORKPLACE ACT:

If this is a solicitation for a public improvement construction contract, the vendor, by its signature below, affirms that it has a written plan for a drug-free workplace policy in compliance with Article 1D, Chapter 21 of the *West Virginia Code*. The vendor **must** make said affirmation with its bid submission. Further, public improvement construction contract may not be awarded to a vendor who does not have a written plan for a drug-free workplace policy in compliance with Article 1D, Chapter 21 of the *West Virginia Code* and who has not submitted that plan to the appropriate contracting authority in timely fashion. For a vendor who is a subcontractor, compliance with Section 5, Article 1D, Chapter 21 of the *West Virginia Code* may take place before their work on the public improvement is begun.

ANTITRUST:

In submitting a bid to any agency for the state of West Virginia, the bidder offers and agrees that if the bid is accepted the bidder will convey, sell, assign or transfer to the state of West Virginia all rights, title and interest in and to all causes of action it may now or hereafter acquire under the antitrust laws of the United States and the state of West Virginia for price fixing and/or unreasonable restraints of trade relating to the particular commodities or services purchased or acquired by the state of West Virginia. Such assignment shall be made and become effective at the time the purchasing agency tenders the initial payment to the bidder.

I certify that this bid is made without prior understanding, agreement, or connection with any corporation, firm, limited liability company, partnership or person or entity submitting a bid for the same materials, supplies, equipment or services and is in all respects fair and without collusion or fraud. I further certify that I am authorized to sign the certification on behalf of the bidder or this bid.

LICENSING:

Vendors must be licensed and in good standing in accordance with any and all state and local laws and requirements by any state or local agency of West Virginia, including, but not limited to, the West Virginia Secretary of State's Office, the West Virginia Tax Department, West Virginia Insurance Commission, or any other state agencies or political subdivision. Furthermore, the vendor must provide all necessary releases to obtain information to enable the Director or spending unit to verify that the vendor is licensed and in good standing with the above entities.

CONFIDENTIALITY:

The vendor agrees that he or she will not disclose to anyone, directly or indirectly, any such personally identifiable information or other confidential information gained from the agency, unless the individual who is the subject of the information consents to the disclosure in writing or the disclosure is made pursuant to the agency's policies, procedures and rules. Vendor further agrees to comply with the Confidentiality Policies and Information Security Accountability Requirements, set forth in <http://www.state.wv.us/admin/purchase/privacy/noticeConfidentiality.pdf>.

Under penalty of law for false swearing (*West Virginia Code* §61-5-3), it is hereby certified that the vendor affirms and acknowledges the information in this affidavit and is in compliance with the requirements as stated.

Vendor's Name: Blue Ridge Machinery & Tools, Inc.

Authorized Signature: _____

Date: 3/18/09

SHEAR BRAKING POWER

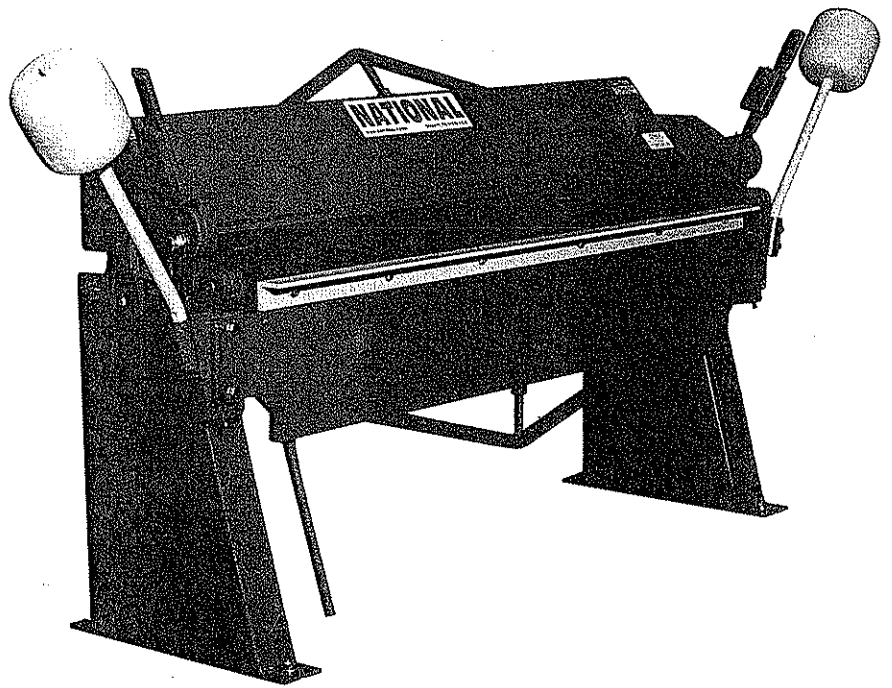

NATIONAL

3 Year Warranty
Made in the U.S.A.

NATIONAL

52" 16 Gauge Metal Shears

National foot shears are designed for precise shearing through 16 gauge mild steel. This shear is also recommended for shearing aluminum, plastic, copper, brass and lead. All cast iron body with four cutting edge high carbon, high chromium blades, back gauges, table gauges, spring actuated hold down, front arm extensions, bottom treadle safety stop and full three year warranty.

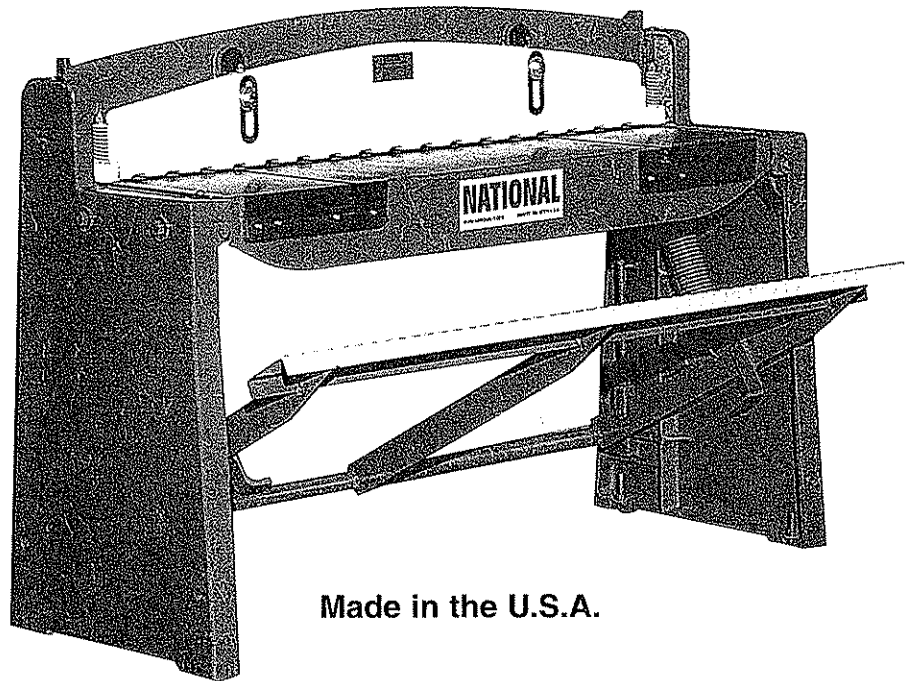

Made in the U.S.A.

STANDARD HIGH CARBON
HIGH CHROMIUM BLADES

3 Year Warranty

Specifications

Model	N5216
Capacity: (Tensile Strength 55,000 lbs. @ rated capacity)	Mild Steel 16 Gauge: 1.6mm Stainless Steel 20 Gauge: .9 mm
Cutting length	52" 1321mm
Shipping Weight	980lbs 445 kgs
Floor Space w/Gauges	61" x 75 7/8" x 42 1/4" 1549 x 1927 x 1073mm
Floor Space w/o Gauges	61" x 34 1/4" x 42 1/4" 1549 x 870 x 1073mm

NATIONAL

National offers three heavy duty all cast iron body shears. These air shears are standard with four cutting edge high carbon high chromium blades, front arm extensions, table gauges, back gauges, and heavy duty foot switch.

Optional Accessories:

57" Squaring arm
Model NSA 52

Air Shears

36" 12 Gauge

52" 16 Gauge

52" 12 Gauge

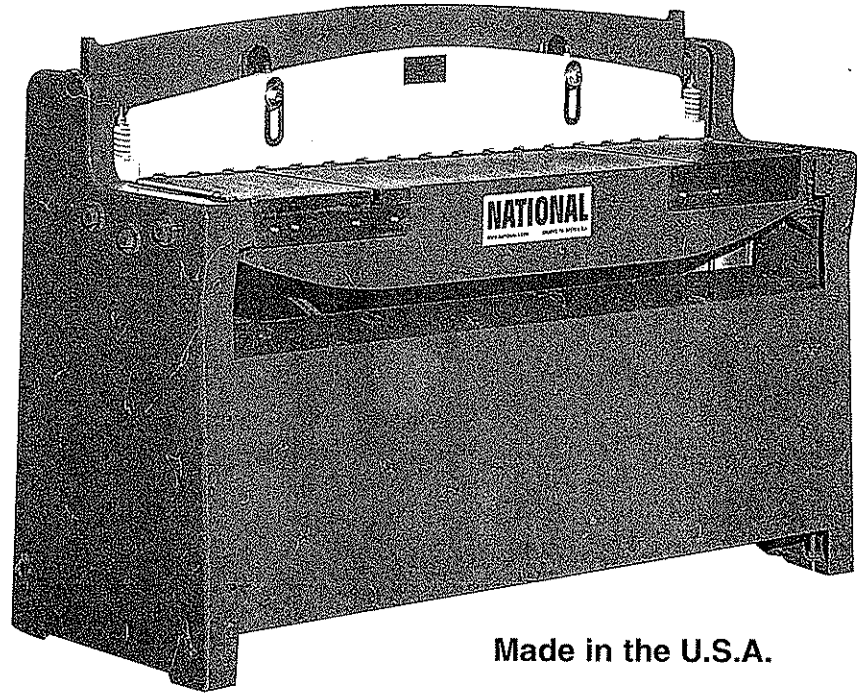

Made in the U.S.A.

3 Year Warranty

STANDARD HIGH CARBON
HIGH CHROMIUM BLADES

Specifications

Model	NA3612	NA5216	NA5212
Capacity:	Mild Steel	Mild Steel	Mild Steel
(Tensile Strength	12 Gauge: 2.7mm	16 Gauge: 1.6mm	12 Gauge: 2.7mm
55,000 lbs. @ rated capacity)	Stainless Steel	Stainless Steel	Stainless Steel
	16 Gauge: 1.6mm	20 Gauge: .9mm	16 Gauge: 1.6mm
Strokes Per Minute	Approx. 40	Approx. 40	Approx. 40
Cutting length	36"	52"	52"
	914mm	1321mm	1321mm
Shipping Weight	1100lbs	1400lbs	1600lbs
	499kgs	635kgs	726kgs
Floor Space w/Gauges	45" x 75 7/8" x 42 1/4"	61" x 75 7/8" x 42 1/4"	62" x 75 7/8" x 42 1/4"
	1143 x 1927 x 1073mm	1549 x 1927 x 1073mm	1575 x 1927 x 1073mm
Floor Space w/o Gauges	45" x 22 3/4" x 42 1/4"	61" x 22 3/4" x 42 1/4"	62" x 22 3/4" x 42 1/4"
	1143 x 578 x 1073mm	1549 x 578 x 1073mm	1575 x 578 x 1073mm
Recommended p.s.i.	100	100	100

NATIONAL

Hydraulic Shears

36" 12 Gauge

52" 16 Gauge

52" 12 Gauge

52" 10 Gauge

National heavy duty power shears are equipped with a fully integrated hydraulic unit. Complete with electrical hydraulic valve, pilot operated-pressure relief valve, heavy duty foot switch that allows this unit to return to the top of the stroke when the operator removes his foot from the foot switch. Heavy duty double acting cylinders Fully enclosed control panel.

The National shear is actuated by a portable shrouded electric foot switch attached to a long flexible cable so it may be positioned comfortable to the operator

Extra Heavy cast iron body with solid 4-edge high carbon high chromium blades. Quick adjusting back gauge for direct reading with a positive lock. Standard with table gauges and front arm extensions

Optional Accessories:

Front operated digital back gauge

Models: NBG36, NBG52

Squaring Arm

Model: NSA52

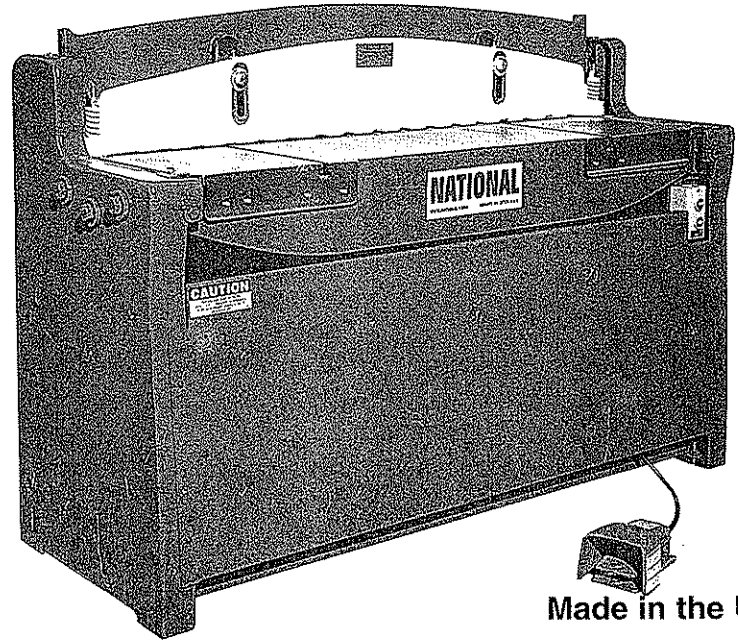

Made in the U.S.A.

3 Year Warranty

STANDARD HIGH CARBON
HIGH CHROMIUM BLADES

Specifications

Model	NH3612	NH5216	NH5212	NH5210
Capacity: (Tensile Strength 55,000 lbs. @ rated capacity)	Mild Steel 12 Gauge: 2.7mm Stainless Steel 16 Gauge: 1.6mm	Mild Steel 16 Gauge: 1.6mm Stainless Steel 20 Gauge: .9mm	Mild Steel 12 Gauge: 2.7mm Stainless Steel 16 Gauge: 1.6mm	Mild Steel 10 Gauge: 3.4mm Stainless Steel 14 Gauge: 1.9mm
Strokes Per Minute	Approx. 40	Approx. 25	Approx. 25	Approx. 25
Cutting length	36" 914mm	52" 1321mm	52" 1321mm	52" 1321mm
Shipping Weight	1200lbs 544kgs	1400lbs 635kgs	1600lbs 726kgs	1950lbs 885kgs
Floor Space w/Gauges	45" x 75 7/8" x 42 1/4" 1143 x 1927 x 1073mm	61" x 75 7/8" x 42 1/4" 1549 x 1927 x 1073mm	61" x 75 7/8" x 42 1/4" 1549 x 1927 x 1073mm	62" x 79 7/8" x 42 1/4" 1575 x 2029 x 1073mm
Floor Space w/o Gauges	45" x 22 3/4" x 42 1/4" 1143 x 578 x 1073mm	61" x 22 3/4" x 42 1/4" 1549 x 578 x 1073mm	61" x 22 3/4" x 42 1/4" 1549 x 578 x 1073mm	62" x 22 3/4" x 42 1/4" 1575 x 578 x 1073mm
Oil Reservoir Capacity	14 gal 53 liters	24 gal 91 liters	24 gal 91 liters	24 gal 91 liters
Motor	3 h.p. 208 volt 1800 rpm 240 volt 3 phase 460 volt	3 h.p. 208 volt 1800 rpm 240 volt 3 phase 460 volt	3 h.p. 208 volt 1800 rpm 240 volt 3 phase 460 volt	5 h.p. 208 volt 1800 rpm 240 volt 3 phase 460 volt

NATIONAL

Hydraulic Shears

6' 1/4"

4' 1/4"

National offers two powerful heavy duty cast iron precision hydraulic shears standard with hydraulic rubber inserted rollers, quick adjusting hand wheel back gauge for direct reading with a positive lock, front arm extensions, table gauges, heavy duty foot switch and well lighted work area. You receive a full three year warranty. The hydraulic unit conforms to J.I.C. standards featuring simplicity of design. The National hydraulic system is simple to maintain with standard replacement parts such as valves, cylinders, hoses and oil. The National shear is actuated by a portable shrouded electric foot switch attached to a long flexible cable so it may be positioned comfortable to the operator.

National Shears have high carbon, high chromium blades with four cutting edges of premium quality tool steel and will withstand nicking and wear better than relieved blades. National blades are secured to the shear with tempered flat head screws through countersunk holes in blades. Complete cuts of full width pieces are 2" longer than specified cutting length. The high strength cast iron constructed frame is made of the highest tensile strength metal needed for long life and accurate shearing. Underdrive construction with downward cylinders and major hydraulics under the bed gives the shear a low profile.

Optional Accessories:

Front operated digital back gauge

Models: NBG48, NBG72

Squaring Arm

Models: NSA48, NSA72

3 Year Warranty



Made in the U.S.A.

STANDARD HIGH CARBON
HIGH CHROMIUM BLADES

Specifications

	NH4825	NH7225
Model	NH4825	NH7225
Capacity: (Tensile Strength 55,000 lbs. @ rated capacity)	Mild Steel 1/4"/6.4mm Stainless 1/8"/3.2mm	Mild Steel 1/4"/6.4mm Stainless 1/8"/3.2mm
Strokes Per Minute	Approx. 20	Approx. 20
Cutting length	48"/1219mm	72"/1829mm
Shipping Weight	5000lbs/2268kgs	6000lbs/2722kgs
Floor Space w/Gauges	66 1/2" x 98" x 54" 1689 x 2489 x 1372mm	84" x 98" x 54" 2134 x 2489 x 1372mm
Floor Space w/o Gauges	66 1/2" x 38" x 54" 1689 x 965 x 1372mm	84" x 38" x 54" 2134 x 965 x 1372mm
Oil Reservoir Capacity	24gal/91 liters	24gal/91 liters
Motor	7 1/2 h.p. 208 volt 1800 rpm 240 volt 3 phase 460 volt	7 1/2 h.p. 208 volt 1800 rpm 240 volt 3 phase 460 volt

NATIONAL

48" 16 Gauge Heavy Duty Brakes

Simplicity of design allows these brakes to work in the most direct fashion. Easy to set up and operate. Body sections are welded steel plates, with heavy truss rods and braces for longer life and greater strength. These brakes are standard with extension handles, apron stop for repeat bends, and replaceable bushings at points of wear.

Made in the U.S.A.

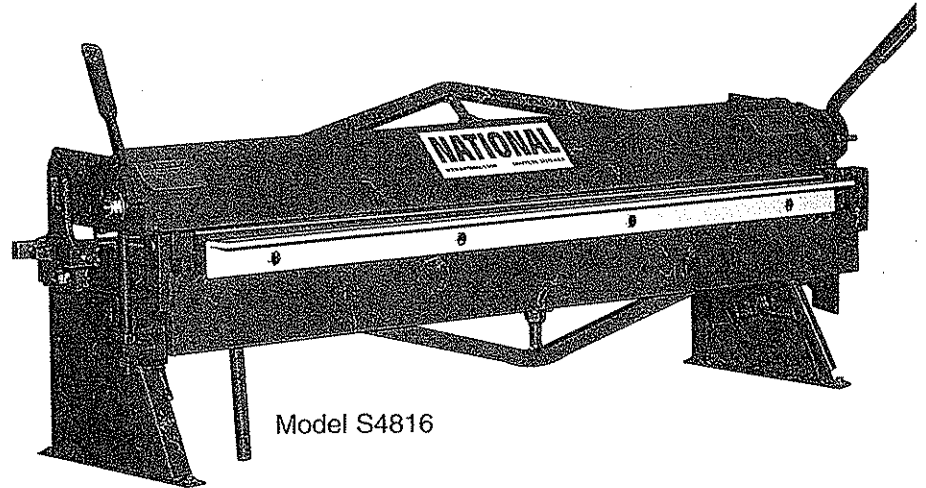

Model S4816

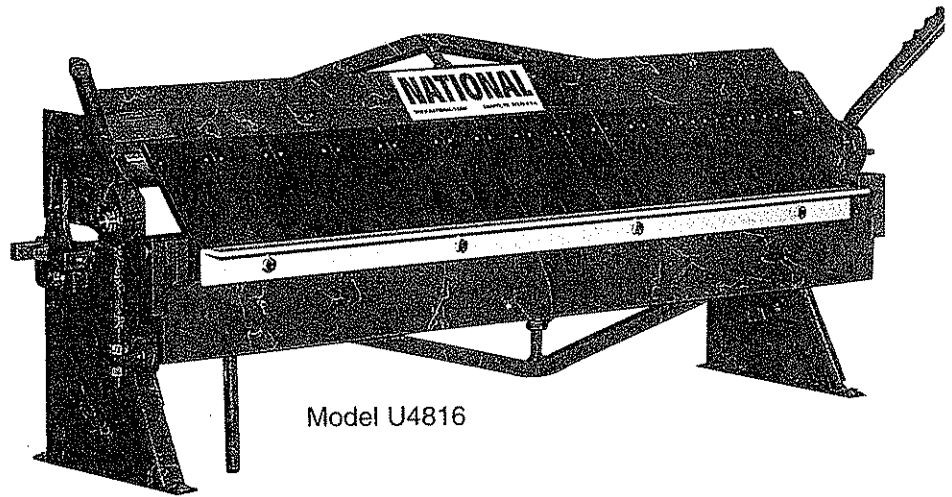

Model U4816

3 Year Warranty

Specifications

	U4816	S4816	Stand
Model	U4816	S4816	Stand
Capacity: (Yield Strength 30,000 lbs. @ rated capacity)	Mild Steel 16 Gauge 1.6mm Stainless 20 Gauge .9mm	Mild Steel 16 Gauge 1.6mm Stainless 20 Gauge .9mm	
Maximum Lift of Beam	1 1/4"/32mm	1 1/4"/32mm	
Finger Width	2" 3" 4" 51mm 76mm 102mm		
Maximum Depth of Box	4"/102mm		
Bending Length	48 1/4"/1226mm	48 1/4"/1226mm	
Shipping Weight	500lbs/227kgs 1689 x 965 x 1372mm	470lbs/213kgs 2134 x 965 x 1372mm	100lbs/45kgs
Floor Space			54"x19"x27 1/4" 1372x483x692mm

NATIONAL

National has four popular floor model box and pan brakes designed to be easy and simple to operate. Standard with 2", 3" and 4" finger widths, stop rods for repeat bends, no large counterweights, and precision bearings on the apron. All steel body construction with extra heavy tie rods for minimum deflection.

Box and Pan Brakes

4' 12 Gauge

6' 16 Gauge

6' 12 Gauge

8' 16 Gauge

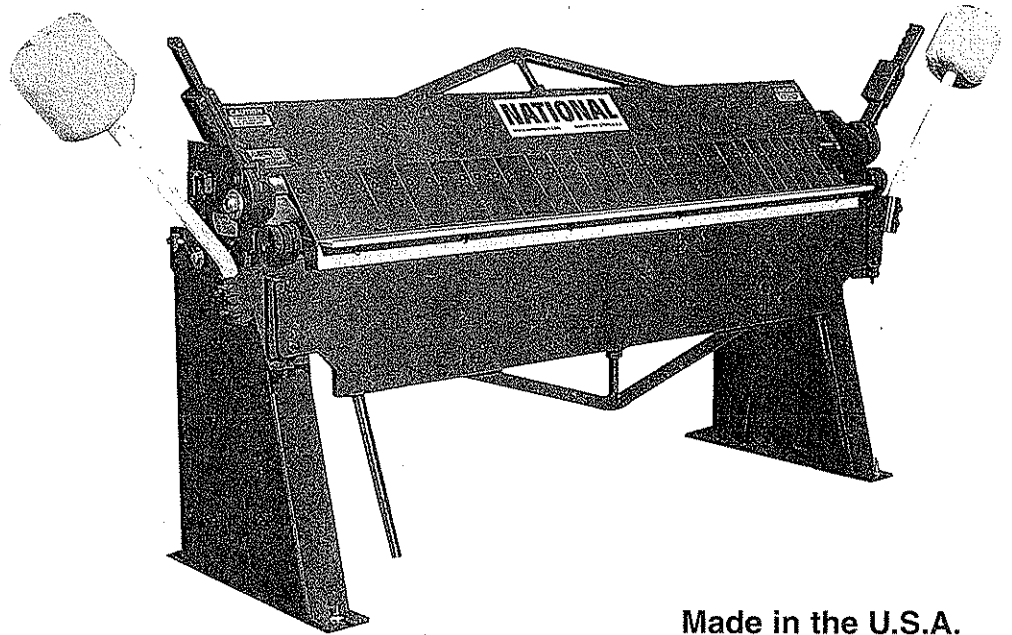

Made in the U.S.A.

3 Year Warranty

Specifications

Model	U4812	U7216	U7212	U9616
Capacity: (Yield Strength 30,000 lbs. @ rated capacity)	Mild Steel 12 Gauge: 2.7mm Stainless Steel 16 Gauge: 1.6mm	Mild Steel 16 Gauge: 1.6mm Stainless Steel 20 Gauge: .9mm	Mild Steel 12 Gauge: 2.7mm Stainless Steel 16 Gauge: 1.6mm	Mild Steel 16 Gauge: 1.6mm Stainless Steel 20 Gauge: .9mm
Finger Width	2", 3", 4" 51, 76, 102mm	2", 3", 4" 51, 76, 102mm	2", 3", 4" 51, 76, 102mm	2", 3", 4" 51, 76, 102mm
Minimum Depth of Box	4"/102mm	4"/102mm	4"/102mm	4"/102mm
Bending Length	49"/1245mm	73"/1854mm	73"/1854mm	97"/2464mm
Shipping Weight	1150lbs/522kgs	1850lbs/839kgs	2100lbs/953kgs	2200lbs/998kgs
Floor Space w/counterweight	95" x 27" x 55" 2413 x 686 x 1397mm	119" x 27" x 55" 3023 x 686 x 1397mm	129" x 27" x 59" 3277 x 686 x 1499mm	143" x 27" x 55" 3632 x 686 x 1397mm

NATIONAL

Heavy Duty Box and Pan Brakes 6" Box Depth

Made in the U.S.A.

National offers four heavy duty box and pan brakes made in the U.S.A. Standard with heavy body construction, precision bearings on the apron, two large cast iron counterweights and apron stop for repeat bends. The National name means quality.

Section fingers are precision machined from rolled steel bar stock for maximum strength. The fingers can be adjusted or removed quickly by the loosening of a thumb screw. Heavy duty steel plates and tension bars are precision incorporated for minimum deflection.

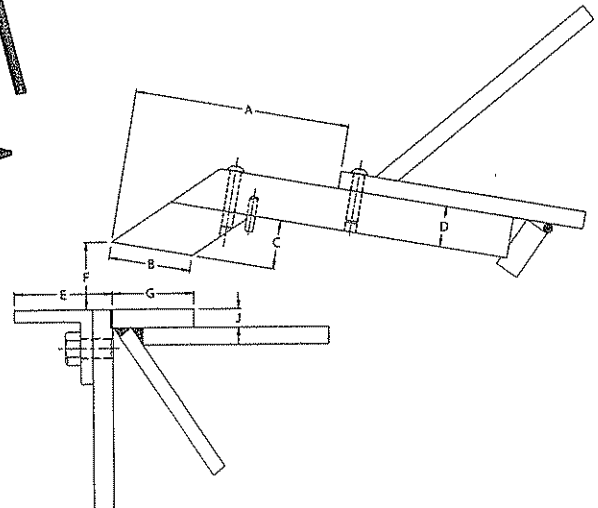
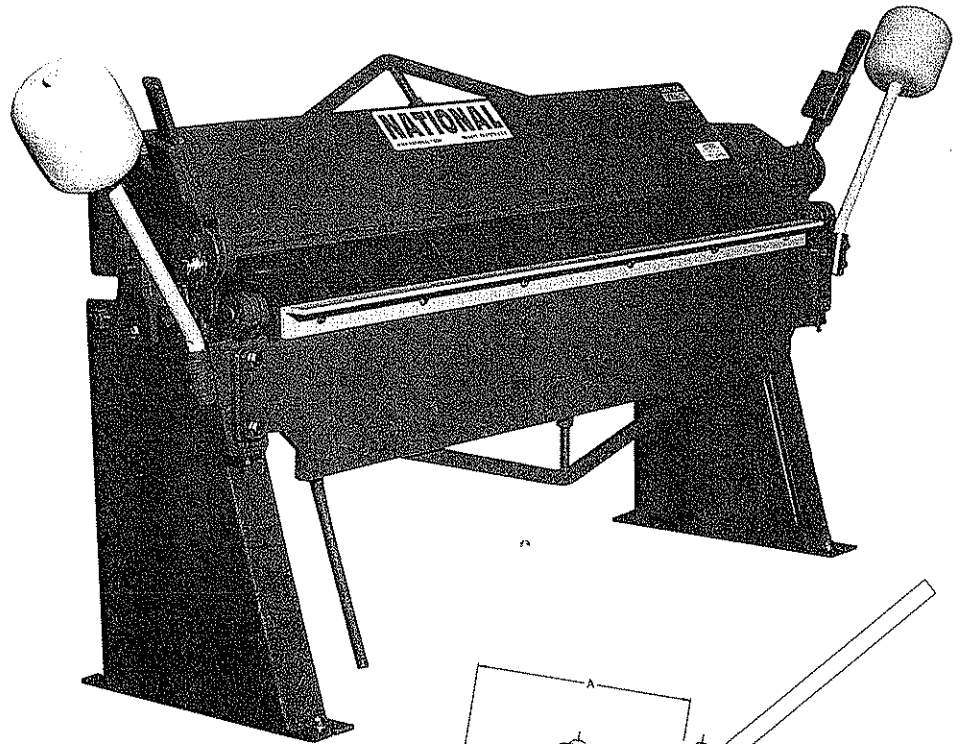

- A - 6 5/16"
- B - 2 1/2"
- C - 1 1/2"
- D - 1 1/4"
- E - Approx. 3"
- F - 2 5/16"
- G - Approx. 2 1/2"
- J - Approx. 9/16"

3 Year Warranty

Finger Width	3" 76mm	4" 102mm	5" 127mm	6" 152mm	Total
U6-4812	5	2	5	0	12
U6-7212	5	4	7	1	17
U6-9614	5	6	9	2	22
U6-12016	6	10	10	2	28

Specifications

	U6-4812	U6-7212	U6-9614	U6-12016
Model	U6-4812	U6-7212	U6-9614	U6-12016
Capacity: (Yield Strength 30,000 lbs. @ rated capacity)	Mild Steel 12 Gauge: 2.7mm Stainless Steel 16 Gauge: 1.6mm	Mild Steel 12 Gauge: 2.7mm Stainless Steel 16 Gauge: 1.6mm	Mild Steel 14 Gauge: 1.9mm Stainless Steel 18 Gauge: 1.2mm	Mild Steel 16 Gauge: 1.6mm Stainless Steel 20 Gauge: .9mm
Minimum Depth of Box	6"/152mm	6"/152mm	6"/152mm	6"/152mm
Bending Length	49"/1245mm	73"/1854mm	97"/2464mm	121"/3073mm
Shipping Weight	1900lbs/862kgs	2530lbs/1148kgs	2800lbs/1270kgs	3200lbs/1452kgs
Floor Space w/counterweight	95" x 27" x 55" 2413 x 686 x 1397mm	126 1/2" x 29" x 59" 3213 x 737 x 1499mm	153" x 27" x 59" 3886 x 686 x 1499mm	177" x 29" x 59" 4496 x 737 x 1499mm

NATIONAL

National offers these hand brakes with a great deal of pride. A simple design, utmost strength with a long life of dependable service. Streamline designed for fast accurate bending — even for the inexperienced workman. Heavy steel body construction with extra heavy tie rods for perfect alignment. Precision bearings on the drum assures you of a smooth operating brake. These brakes come with a full three year warranty.

Hand Brakes

4' 12 Gauge

6' 12 Gauge

8' 16 Gauge

8' 14 Gauge

10' 16 Gauge

10' 14 Gauge

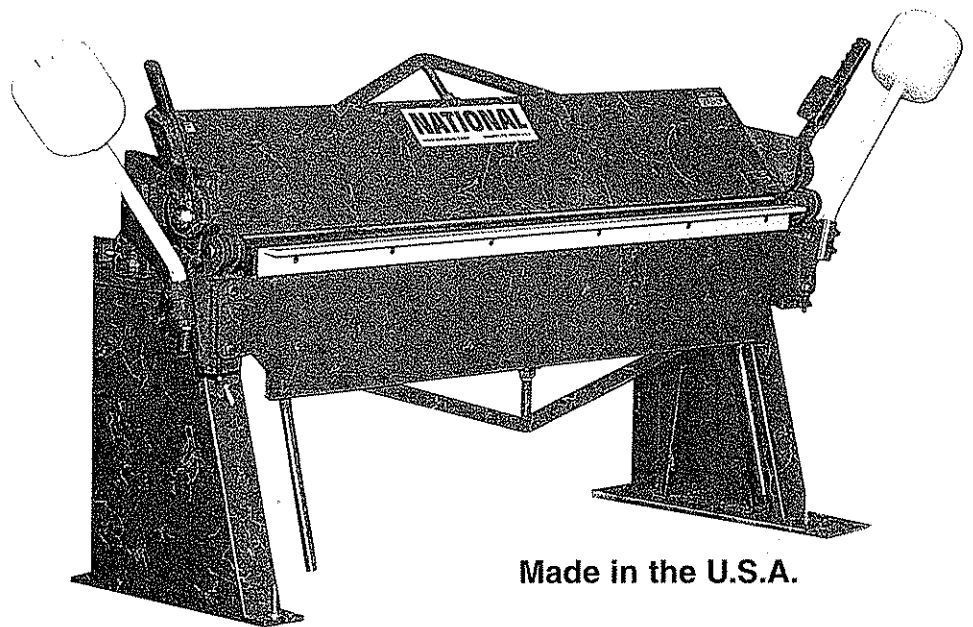

Made in the U.S.A.

3 Year Warranty

Specifications

Model	N4812	N7212	N9616
Capacity: (Yield Strength 30,000 lbs. @ rated capacity)	Mild Steel 12 Gauge: 2.7mm Stainless 16 Gauge: 1.6mm	Mild Steel 12 Gauge: 2.7mm Stainless 16 Gauge: 1.6mm	Mild Steel 16 Gauge: 1.6mm Stainless 20 Gauge: .9mm
Bending Length	49"/1245mm	73"/1854mm	97"/2464mm
Shipping Weight	1050lbs/476kgs	1800lbs/816kgs	1600lbs/726kgs
Floor Space w/Counterweight	95" x 27" x 55" 2413 x 686 x 1397mm	129" x 27" x 59" 3277 x 686 x 1499mm	143" x 27" x 55" 3632 x 686 x 1397mm
Model	N9614	N12016	N12014
Capacity: (Yield Strength 30,000 lbs. @ rated capacity)	Mild Steel 14 Gauge: 1.9mm Stainless 18 Gauge: 1.2mm	Mild Steel 16 Gauge: 1.6mm Stainless 20 Gauge: .9mm	Mild Steel 14 Gauge: 1.9mm Stainless 18 Gauge: 1.2mm
Bending Length	97"/2464mm	121"/3073mm	121"/3073mm
Shipping Weight	1750lbs/794kgs	2800lbs/1270kgs	3200lbs/1452kgs
Floor Space w/Counterweight	153" x 27" x 59" 3886 x 686 x 1499mm	177" x 29" x 59" 4496 x 737 x 1499mm	177" x 29" x 59" 4496 x 737 x 1499mm

NATIONAL

48" and 72" x 16 Gauge Power Roll Forming Machine

National's 3" power rolls are designed for simple operation. All three rolls are power driven. Standard with forward and reverse drum switch. Quick release upper roll. Positive chain drive. Heavy duty gear box. Front guard for additional safety. Heavy duty stand is standard.

National's rolls incorporate three precision turned, ground, and polished high carbon steel rolls. Extra heavy duty end frames with quick release handle on the right front for speedy production forming.

The drive train is powered with a heavy duty precision reduction gear box to assure durability and long life. The electric panel and gear box are housed in a ventilated stand for protection.

Precision roll adjustment is achieved by turning the hand wheel on the left end of the roll. Repeatability is maintained by the forming scale above the hand wheel.

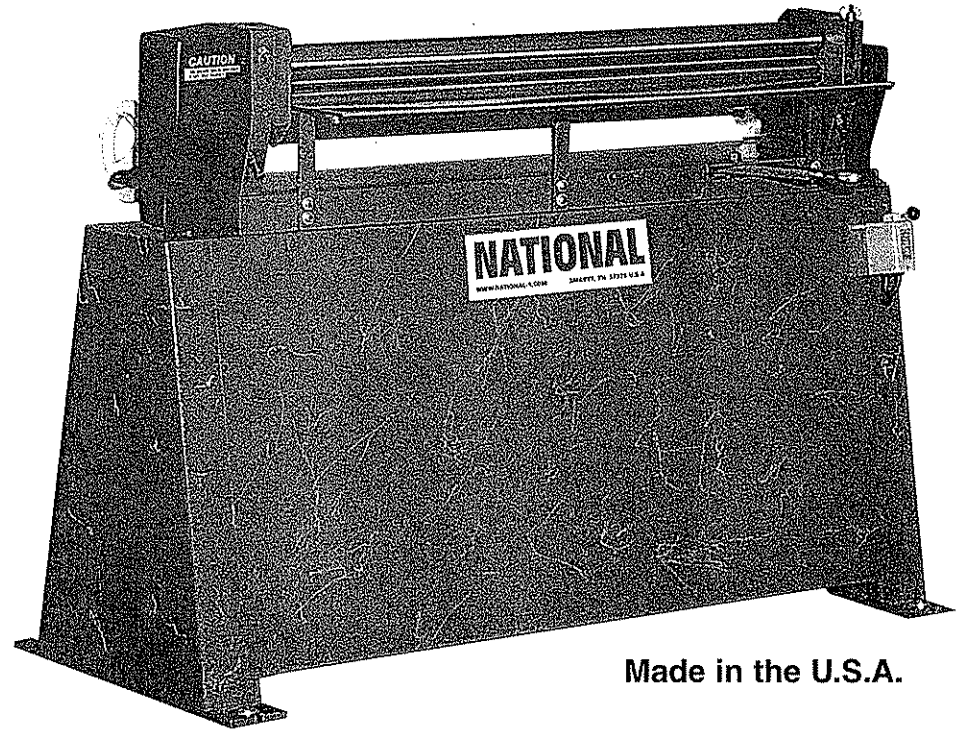

Made in the U.S.A.

3 Year Warranty

Specifications

	NR4816	NR7216
Model	NR4816	NR7216
Capacity: (Yield Strength 30,000 lbs. @ rated capacity)	16 Gauge: 1.6mm	16 Gauge: 1.6mm
Maximum Forming Length	48 1/4"/1226mm	72 1/4"/1835mm
Diameter of Roll	3"/76mm	4"/102mm
Minimum Forming Radius	1 1/2"/38mm	2"/51mm
Wire Grooves (Optional)	3/8", 1/2", 5/8"/10mm, 13mm, 16mm	3/8", 1/2", 5/8"/10mm, 13mm, 16mm
Roll Speed	18 rpm/14.13 sfpm	18 rpm/14.13 sfpm
Motor: 110-220 Single PH 208-220-440 3 PH	1 hp	1 hp
Floor Space (l x w x h)	64" x 37" x 44 1/2" 1626 x 940 x 1130mm	88" x 26" x 43 3/4" 2335 x 660 x 1111mm
Shipping Weight	970lbs/440kgs	1740lbs/814kgs

NATIONAL

Front Operated Digital Back Gauge

L.E.D. CONTROL

Precision digital front operated back gauge
 Control panel located out of the work area, yet convenient for the operator.
 Precision Thomson bearings
 Max travel 30"/762mm
 Precision reliable repeatability improves cutting accuracy.
 Shipped assembled for easy mounting
 Digital readout in increments of one thousandth of an inch
 No memory loss due to power failure
 Easy mounting; can be retrofitted to any National shear

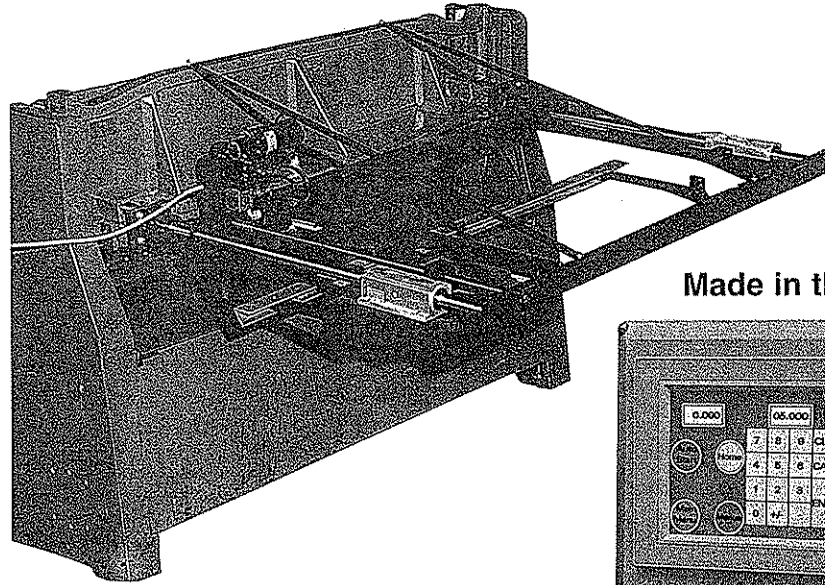

Made in the U.S.A.

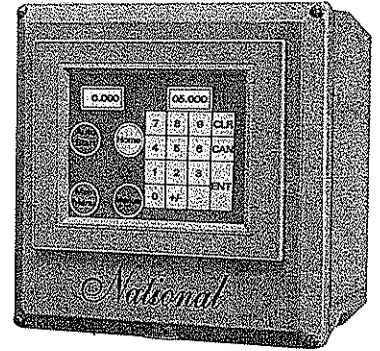

3 Year Warranty

Specifications

Model	NBG36	NBG52	NBG48	NBG72
Floor Space (l x w x h)	36" x 44" x 16 1/2"	51 1/2" x 44" x 16 1/2"	51 1/2" x 48" x 19"	72" x 48" x 19"
	915 x 1118 x 419mm	1302 x 1118 x 419mm	1302 x 1219 x 483mm	1829 x 1219 x 483mm
Shipping Weight	300lbs/136kgs	340lbs/154kgs	380lbs/172kgs	480lbs/218kgs
Travel	30"/762mm	30"/762mm	30"/762mm	30"/762mm

Squaring Arm

National brings to you a squaring arm constructed of high tensile strength, durable solid cast iron. National's squaring arm comes with 57" to 60" black oxidized scale with 1/16" increments. This squaring arm comes with jack screws for easy leveling. National's squaring arms are easily assembled on the left side of the machine.

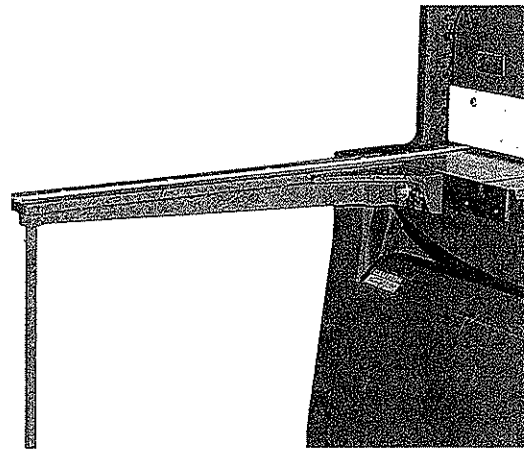

Made in the U.S.A.

3 Year Warranty

Specifications

Model	NSA52	NSA48	NSA72
Length	43 1/2"/1105mm	45"/1143mm	45"/1143mm
Shipping Weight	72lbs/33kgs	107lbs/49kgs	107lbs/49kgs

NATIONAL

Made in the U.S.A.

Sheet Metal Machines, Inc.

P.O. Box 72
Smartt, Tennessee 37378
Phone: 931-668-3643
Fax: 931-668-3177
www.national-1.com
National_1@blomand.net

Warranty

Each machine will be warranted for a period of three years from date of shipment. The warranty will cover the cost of any parts found to be defective upon our examination. We will not be liable for any shipping charges, installation costs or any other expenses. This Warranty will not apply to modified machines, misuse or unauthorized repair work.

National Sheet Metal Machines, Inc. reserves the right to change design and parts for the enhancement of machines at our discretion.

3 Year Warranty

Distributed By: