



State of West Virginia
 Department of Administration
 Purchasing Division
 2019 Washington Street East
 Post Office Box 50130
 Charleston, WV 25305-0130

Request for Quotation

RFQ NUMBER
709EC006

PAGE
1

ADDRESS CORRESPONDENCE TO ATTENTION OF
MICHAEL AUSTIN
304-558-2402

VENDOR
 *709054014 304-776-4406
 STATE EQUIPMENT INC
 PO BOX 3939
 CHARLESTON WV 25339

SHIP TO
 DIVISION OF HIGHWAYS
 EQUIPMENT DIVISION
 ROUTE 33
 BRUSHY FORK ROAD
 BUCKHANNON, WV
 26201 304-472-1750

DATE PRINTED 09/23/2008	TERMS OF SALE <i>Net 30 Days</i>	SHIP VIA <i>State Equipment</i>	F.O.B. <i>Buckhannon WV</i>	FREIGHT TERMS
-----------------------------------	-------------------------------------	------------------------------------	--------------------------------	---------------

BID OPENING DATE: **10/22/2008** BID OPENING TIME **01:30PM**

LINE	QUANTITY	UOP	CAT NO	ITEM NUMBER	UNIT PRICE	AMOUNT
0001	1	EA		968-39 <i>Case CX135</i>	<i>\$98,500.00</i>	<i>\$98,500.00</i>
<p>OPEN END CONTRACT</p> <p>TO PROVIDE HYDRAULIC TRACK EXCAVATOR FOR THE WEST VIRGINIA DIVISION OF HIGHWAYS PER THE ATTACHED SPECIFICATIONS.</p> <p>THERE WILL BE A MANDATORY PRE-BID CONFERENCE AT THE EQUIPMENT DIVISION IN BUCKHANNON, WEST VIRGINIA AT 10:00 AM ON 10/09/2008. FAILURE TO ATTEND THE PRE-BID WILL RESULT IN BID DISQUALIFICATION.</p> <p>QUESTIONS: WRITTEN QUESTIONS MUST BE RECEIVED BY CLOSE OF BUSINESS (5:00 PM EST.) ON FRIDAY, 10/03/08. SEND YOUR QUESTIONS TO: PURCHASING DIVISION ATTENTION MICHAEL AUSTIN 2019 WASHINGTON STREET EAST CHARLESTON, WV 25305</p> <p>QUESTIONS MAY BE SENT VIA FAX, E-MAIL OR REGULAR MAIL. E-MAIL: MICHAEL.D.AUSTIN@WV.GOV FAX: 304-558-4115</p> <p>IT IS THE VENDORS RESPONSIBILITY TO VERIFY THAT THEIR QUESTIONS HAVE BEEN RECEIVED BY CALLING 304-558-2402.</p> <p>EXHIBIT 2</p> <p>LIFE OF CONTRACT: THIS CONTRACT BECOMES EFFECTIVE ON AND EXTENDS FOR A PERIOD OF ONE (1)</p>						

RECEIVED
 2008 NOV 12 P 12:58
 PURCHASING DIVISION
 STATE OF WV

SEE REVERSE SIDE FOR TERMS AND CONDITIONS

SIGNATURE <i>[Signature]</i>	TELEPHONE <i>304 776 4405</i>	DATE <i>10/27/08</i>
TITLE <i>Vice President</i>	FEIN <i>55-0658298</i>	ADDRESS CHANGES TO BE NOTED ABOVE

WHEN RESPONDING TO RFQ, INSERT NAME AND ADDRESS IN SPACE ABOVE LABELED 'VENDOR'

**GENERAL TERMS & CONDITIONS
REQUEST FOR QUOTATION (RFQ) AND REQUEST FOR PROPOSAL (RFP)**

1. Awards will be made in the best interest of the State of West Virginia.
2. The State may accept or reject in part, or in whole, any bid.
3. All quotations are governed by the *West Virginia Code* and the *Legislative Rules* of the Purchasing Division.
4. Prior to any award, the apparent successful vendor must be properly registered with the Purchasing Division and have paid the required \$125 fee.
5. All services performed or goods delivered under State Purchase Order/Contracts are to be continued for the term of the Purchase Order/Contracts, contingent upon funds being appropriated by the Legislature or otherwise being made available. In the event funds are not appropriated or otherwise available for these services or goods, this Purchase Order/Contract becomes void and of no effect after June 30.
6. Payment may only be made after the delivery and acceptance of goods or services.
7. Interest may be paid for late payment in accordance with the *West Virginia Code*.
8. Vendor preference will be granted upon written request in accordance with the *West Virginia Code*.
9. The State of West Virginia is exempt from federal and state taxes and will not pay or reimburse such taxes.
10. The Director of Purchasing may cancel any Purchase Order/Contract upon 30 days written notice to the seller.
11. The laws of the State of West Virginia and the *Legislative Rules* of the Purchasing Division shall govern all rights and duties under the Contract, including without limitation the validity of this Purchase Order/Contract.
12. Any reference to automatic renewal is hereby deleted. The Contract may be renewed only upon mutual written agreement of the parties.
13. **BANKRUPTCY:** In the event the vendor/contractor files for bankruptcy protection, this Contract may be deemed null and void, and terminated without further order.
14. **HIPAA BUSINESS ASSOCIATE ADDENDUM:** The West Virginia State Government HIPAA Business Associate Addendum (BAA), approved by the Attorney General, and available online at the Purchasing Division's web site (<http://www.state.wv.us/admin/purchase/vrc/hipaa.htm>) is hereby made part of the agreement. Provided that, the Agency meets the definition of a Cover Entity (45 CFR §160.103) and will be disclosing Protected Health Information (45 CFR §160.103) to the vendor.
15. **WEST VIRGINIA ALCOHOL & DRUG-FREE WORKPLACE ACT:** If this Contract constitutes a public improvement construction contract as set forth in Article 1D, Chapter 21 of the West Virginia Code ("The West Virginia Alcohol and Drug-Free Workplace Act"), then the following language shall hereby become part of this Contract: "The contractor and its subcontractors shall implement and maintain a written drug-free workplace policy in compliance with the West Virginia Alcohol and Drug-Free Workplace Act, as set forth in Article 1D, Chapter 21 of the West Virginia Code. The contractor and its subcontractors shall provide a sworn statement in writing, under the penalties of perjury, that they maintain a valid drug-free work place policy in compliance with the West Virginia and Drug-Free Workplace Act. It is understood and agreed that this Contract shall be cancelled by the awarding authority if the Contractor: 1) Fails to implement its drug-free workplace policy; 2) Fails to provide information regarding implementation of the contractor's drug-free workplace policy at the request of the public authority; or 3) Provides to the public authority false information regarding the contractor's drug-free workplace policy."

INSTRUCTIONS TO BIDDERS

1. Use the quotation forms provided by the Purchasing Division.
2. **SPECIFICATIONS:** Items offered must be in compliance with the specifications. Any deviation from the specifications must be clearly indicated by the bidder. Alternates offered by the bidder as **EQUAL** to the specifications must be clearly defined. A bidder offering an alternate should attach complete specifications and literature to the bid. The Purchasing Division may waive minor deviations to specifications.
3. Complete all sections of the quotation form.
4. Unit prices shall prevail in case of discrepancy.
5. All quotations are considered F.O.B. destination unless alternate shipping terms are clearly identified in the quotation.
6. **BID SUBMISSION:** All quotations must be delivered by the bidder to the office listed below prior to the date and time of the bid opening. Failure of the bidder to deliver the quotations on time will result in bid disqualifications: Department of Administration, Purchasing Division, 2019 Washington Street East, P.O. Box 50130, Charleston, WV 25305-0130



State of West Virginia
 Department of Administration
 Purchasing Division
 2019 Washington Street East
 Post Office Box 50130
 Charleston, WV 25305-0130

Request for Quotation

RFQ NUMBER
709EC006

PAGE
2

ADDRESS CORRESPONDENCE TO ATTENTION OF
MICHAEL AUSTIN 304-558-2402

VENDOR

*709054014 304-776-4406
 STATE EQUIPMENT INC
 PO BOX 3939
 CHARLESTON WV 25339

SHIP TO

DIVISION OF HIGHWAYS
 EQUIPMENT DIVISION
 ROUTE 33
 BRUSHY FORK ROAD
 BUCKHANNON, WV
 26201 304-472-1750

DATE PRINTED	TERMS OF SALE	SHIP VIA	FOB	FREIGHT TERMS
09/23/2008				

BID OPENING DATE: 10/22/2008 BID OPENING TIME 01:30PM

LINE	QUANTITY	UOP	CAT NO	ITEM NUMBER	UNIT PRICE	AMOUNT
<p>YEAR OR UNTIL SUCH "REASONABLE TIME" THEREAFTER AS IS NECESSARY TO OBTAIN A NEW CONTRACT OR RENEW THE ORIGINAL CONTRACT. THE "REASONABLE TIME" PERIOD SHALL NOT EXCEED TWELVE (12) MONTHS. DURING THIS "REASONABLE TIME" THE VENDOR MAY TERMINATE THIS CONTRACT FOR ANY REASON UPON GIVING THE DIRECTOR OF PURCHASING THIRTY (30) DAYS WRITTEN NOTICE.</p> <p>UNLESS SPECIFIC PROVISIONS ARE STIPULATED IN THIS CONTRACT DOCUMENT, THE TERMS, CONDITIONS, AND PRICING SET HEREIN ARE FIRM FOR THE LIFE OF THE CONTRACT.</p> <p>RENEWAL: THIS CONTRACT MAY BE RENEWED UPON THE MUTUAL WRITTEN CONSENT OF THE SPENDING UNIT AND VENDOR, SUBMITTED TO THE DIRECTOR OF PURCHASING THIRTY (30) DAYS PRIOR TO THE EXPIRATION DATE. SUCH RENEWAL SHALL BE IN ACCORDANCE WITH THE TERMS AND CONDITIONS OF THE ORIGINAL CONTRACT AND SHALL BE LIMITED TO TWO (2) ONE (1) YEAR PERIODS.</p> <p>CANCELLATION: THE DIRECTOR OF PURCHASING RESERVES THE RIGHT TO CANCEL THIS CONTRACT IMMEDIATELY UPON WRITTEN NOTICE TO THE VENDOR IF THE COMMODITIES AND/OR SERVICES SUPPLIED ARE OF AN INFERIOR QUALITY OR DO NOT CONFORM WITH THE SPECIFICATIONS OF THE BID AND CONTRACT HEREIN.</p> <p>OPEN MARKET CLAUSE: THE DIRECTOR OF PURCHASING MAY AUTHORIZE A SPENDING UNIT TO PURCHASE ON THE OPEN MARKET, WITHOUT THE FILING OF A REQUISITION OR COST ESTIMATE, ITEMS SPECIFIED ON THIS CONTRACT FOR IMMEDIATE DELIVERY IN EMERGENCIES DUE TO UNFORESEEN CAUSES (INCLUDING BUT NOT LIMITED TO DELAYS IN TRANSPORTATION OR AN UNANTICIPATED INCREASE IN THE VOLUME OF WORK).</p> <p>QUANTITIES: QUANTITIES LISTED IN THE REQUISITION ARE APPROXIMATIONS ONLY, BASED ON ESTIMATES SUPPLIES BY TH</p>						

SEE REVERSE SIDE FOR TERMS AND CONDITIONS

SIGNATURE	TELEPHONE	DATE
TITLE	FEIN	ADDRESS CHANGES TO BE NOTED ABOVE

WHEN RESPONDING TO RFQ, INSERT NAME AND ADDRESS IN SPACE ABOVE LABELED 'VENDOR'



State of West Virginia
 Department of Administration
 Purchasing Division
 2019 Washington Street East
 Post Office Box 50130
 Charleston, WV 25305-0130

Request for Quotation

RFO NUMBER
709EC006

PAGE
3

ADDRESS CORRESPONDENCE TO ATTENTION OF
**MICHAEL AUSTIN
 304-558-2402**

AUCTION PROPERTY

*709054014 304-776-4406
**STATE EQUIPMENT INC
 PO BOX 3939
 CHARLESTON WV 25339**

SHIP TO

**DIVISION OF HIGHWAYS
 EQUIPMENT DIVISION
 ROUTE 33
 BRUSHY FORK ROAD
 BUCKHANNON, WV
 26201 304-472-1750**

DATE PRINTED 09/23/2008	TERMS OF SALE	SHIP VIA	FOB	FREIGHT TERMS
-----------------------------------	---------------	----------	-----	---------------

BID OPENING DATE: **10/22/2008** BID OPENING TIME **01:30PM**

LINE	QUANTITY	UOP	CAT NO	ITEM NUMBER	UNIT PRICE	AMOUNT
<p>STATE SPENDING UNIT. IT IS UNDERSTOOD AND AGREED THAT THE CONTRACT SHALL COVER THE QUANTITIES ACTUALLY ORDERED FOR DELIVERY DURING THE TERM OF CONTRACT, WHETHER MORE OR LESS THAN THE QUANTITIES SHOWN.</p> <p>ORDERING PROCEDURE: SPENDING UNIT(S) SHALL ISSUE A WRITTEN EQUIPMENT CONTRACT ORDER (FORM NUMBER WV-35) FOR COMMODITIES COVERED BY THIS CONTRACT. THE ORIGINAL WV-35 MUST BE SENT TO THE PURCHASING DIVISION OF THE DEPARTMENT OF ADMINISTRATION. AFTER APPROVAL AND ENCUMBRANCE, ONE COPY OF THE PURCHASE ORDER WILL BE RETURNED TO THE SPENDING UNIT AND ONE COPY FORWARDED TO THE VENDOR AS AUTHORIZATION FOR SHIPMENT. NO ORDER IS VALID UNLESS APPROVED AND ENCUMBERED BY THE PURCHASING DIVISION.</p> <p>BANKRUPTCY: IN THE EVENT THE VENDOR/CONTRACTOR FILES FOR BANKRUPTCY PROTECTION, THIS CONTRACT IS AUTOMATICALLY NULL AND VOID, AND IS TERMINATED WITHOUT FURTHER ORDER.</p> <p>REV. 9/98</p> <p>EXHIBIT 4</p> <p>LOCAL GOVERNMENT BODIES: UNLESS THE VENDOR INDICATES IN THE BID HIS REFUSAL TO EXTEND THE PRICES, TERMS, AND CONDITIONS OF THE BID TO COUNTY, SCHOOL, MUNICIPAL AND OTHER LOCAL GOVERNMENT BODIES, THE BID SHALL EXTEND TO POLITICAL SUBDIVISIONS OF THE STATE OF WEST VIRGINIA. IF THE VENDOR DOES NOT WISH TO EXTEND THE PRICES, TERMS, AND CONDITIONS OF THE BID TO ALL POLITICAL SUBDIVISIONS OF THE STATE, THE VENDOR MUST CLEARLY INDICATE SUCH REFUSAL IN HIS BID. SUCH REFUSAL SHALL NOT PREJUDICE THE AWARD OF THIS CONTRACT IN ANY</p>						

SEE REVERSE SIDE FOR TERMS AND CONDITIONS

SIGNATURE	TELEPHONE	DATE
TITLE	FEIN	ADDRESS CHANGES TO BE NOTED ABOVE

WHEN RESPONDING TO RFQ, INSERT NAME AND ADDRESS IN SPACE ABOVE LABELED 'VENDOR'



State of West Virginia
 Department of Administration
 Purchasing Division
 2019 Washington Street East
 Post Office Box 50130
 Charleston, WV 25305-0130

Request for Quotation

RFQ NUMBER
709EC006

PAGE
4

ADDRESS CORRESPONDENCE TO ATTENTION OF
MICHAEL AUSTIN
304-558-2402

VENDOR

*709054014 304-776-4406
 STATE EQUIPMENT INC
 PO BOX 3939
 CHARLESTON WV 25339

SHIP TO

DIVISION OF HIGHWAYS
 EQUIPMENT DIVISION
 ROUTE 33
 BRUSHY FORK ROAD
 BUCKHANNON, WV
 26201 304-472-1750

DATE PRINTED	TERMS OF SALE	SHIP VIA	F.O.B.	FREIGHT TERMS
09/23/2008				

BID OPENING DATE: **10/22/2008** BID OPENING TIME **01:30PM**

LINE	QUANTITY	UOP	CAT NO	ITEM NUMBER	UNIT PRICE	AMOUNT
	<p>MANNER.</p> <p>REV. 3/88</p> <p>EXHIBIT 6</p> <p>PRICE ADJUSTMENT PROVISION: THE STATE OF WEST VIRGINIA WILL CONSIDER BIDS THAT CONTAIN PROVISIONS FOR PRICE ADJUSTMENTS PRIOR TO THE ORIGINAL EXPIRATION OF THE CONTRACT, PROVIDED THAT SUCH PRICE ADJUSTMENT COVERS BOTH UPWARD AND DOWNWARD MOVEMENT OF THE COMMODITY PRICE, AND THAT ADJUSTMENT IS BASED ON THE "PASS THROUGH" INCREASE OR DECREASE OF RAW MATERIALS AND/OR LABOR, WHICH MAKE UP ALL OR A SUBSTANTIAL PART OF A PRODUCT. ADJUSTMENTS ARE TO BE BASED UPON AN ACTUAL DOLLAR FIGURE, NOT A PERCENTAGE. ALL PRICE ADJUSTMENT REQUESTS MUST BE SUBSTANTIATED IN A MANNER ACCEPTABLE TO THE DIRECTOR PURCHASING, E.G. GOVERNMENTAL BENCH MARKS, GENERAL MARKET INCREASE, PUBLISHED PRICE LISTS. SUCH REQUESTS FOR AND INCREASE SHOULD BE RECEIVED IN WRITING BY THE DIRECTOR OF PURCHASING AT LEAST 30 DAYS IN ADVANCE OF THE EFFECTIV DATE OF THE INCREASE. ANY TIME THE VENDOR REQUESTS A PRICE ADJUSTMENT, THE PURCHASING DIVISION MAY EITHER ACCEPT THE PRICE ADJUSTMENT AND AMEND THE CONTRACT ACCORDINGLY OR REJECT THE ADJUSTMENT IN ITS ENTIRETY AND CANCEL THE CONTRACT.</p> <p>EXHIBIT 10</p> <p>REQUISITION NO.:</p> <p>ADDENDUM ACKNOWLEDGEMENT</p>					

SEE REVERSE SIDE FOR TERMS AND CONDITIONS

SIGNATURE	TELEPHONE	DATE
-----------	-----------	------

TITLE	FEIN	ADDRESS CHANGES TO BE NOTED ABOVE
-------	------	-----------------------------------

WHEN RESPONDING TO RFQ, INSERT NAME AND ADDRESS IN SPACE ABOVE LABELED 'VENDOR'



State of West Virginia
 Department of Administration
 Purchasing Division
 2019 Washington Street East
 Post Office Box 50130
 Charleston, WV 25305-0130

Request for Quotation

RFQ NUMBER
709EC006

PAGE
5

ADDRESS CORRESPONDENCE TO ATTENTION OF
MICHAEL AUSTIN 304-558-2402

RODNEY

*709054014 304-776-4406
 STATE EQUIPMENT INC
 PO BOX 3939
 CHARLESTON WV 25339

SHIP TO

DIVISION OF HIGHWAYS
 EQUIPMENT DIVISION
 ROUTE 33
 BRUSHY FORK ROAD
 BUCKHANNON, WV
 26201 304-472-1750

DATE PRINTED	TERMS OF SALE	SHIP VIA	FOB	FREIGHT TERMS
09/23/2008				

BID OPENING DATE: **10/22/2008** BID OPENING TIME **01:30PM**

LINE	QUANTITY	UOP	CAT NO	ITEM NUMBER	UNIT PRICE	AMOUNT
<p>I HEREBY ACKNOWLEDGE RECEIPT OF THE FOLLOWING CHECKED ADDENDUM(S) AND HAVE MADE THE NECESSARY REVISIONS TO MY PROPOSAL, PLANS AND/OR SPECIFICATION, ETC.</p> <p>ADDENDUM NO.'S:</p> <p>NO. 1 ✓</p> <p>NO. 2 ✓</p> <p>NO. 3 ✓</p> <p>NO. 4</p> <p>NO. 5</p> <p>I UNDERSTAND THAT FAILURE TO CONFIRM THE RECEIPT OF TH ADDENDUM(S) MAY BE CAUSE FOR REJECTION OF BIDS.</p> <p>VENDOR MUST CLEARLY UNDERSTAND THAT ANY VERBAL REPRESENTATION MADE OR ASSUMED TO BE MADE DURING ANY ORAL DISCUSSION HELD BETWEEN VENDOR'S REPRESENTATIVES AND ANY STATE PERSONNEL IS NOT BINDING. ONLY THE INFORMATION ISSUED IN WRITING AND ADDED TO THE SPECIFICATIONS BY AN OFFICIAL ADDENDUM IS BINDING.</p> <p>..... SIGNATURE <i>State Equipment, Inc.</i> COMPANY DATE</p>						

SEE REVERSE SIDE FOR TERMS AND CONDITIONS

SIGNATURE	TELEPHONE	DATE
-----------	-----------	------

TITLE	FEIN	ADDRESS CHANGES TO BE NOTED ABOVE
-------	------	-----------------------------------

WHEN RESPONDING TO RFQ, INSERT NAME AND ADDRESS IN SPACE ABOVE LABELED 'VENDOR'



State of West Virginia
 Department of Administration
 Purchasing Division
 2019 Washington Street East
 Post Office Box 50130
 Charleston, WV 25305-0130

Request for Quotation

RFQ NUMBER
709EC006

PAGE
6

ADDRESS CORRESPONDENCE TO ATTENTION OF
MICHAEL AUSTIN 304-558-2402

VENDOR

*709054014 304-776-4406
 STATE EQUIPMENT INC
 PO BOX 3939
 CHARLESTON WV 25339

SHIP TO

DIVISION OF HIGHWAYS
 EQUIPMENT DIVISION
 ROUTE 33
 BRUSHY FORK ROAD
 BUCKHANNON, WV
 26201 304-472-1750

DATE PRINTED	TERMS OF SALE	SHIP VIA	FOB	FREIGHT TERMS
09/23/2008				

BID OPENING DATE: **10/22/2008** BID OPENING TIME **01:30PM**

LINE	QUANTITY	UOP	CAT NO	ITEM NUMBER	UNIT PRICE	AMOUNT
<p>REV. 11/96</p> <p style="text-align: center;">NOTICE</p> <p>A SIGNED BID MUST BE SUBMITTED TO:</p> <p style="text-align: center;">DEPARTMENT OF ADMINISTRATION PURCHASING DIVISION BUILDING 15 2019 WASHINGTON STREET, EAST CHARLESTON, WV 25305-0130</p> <p>THE BID SHOULD CONTAIN THIS INFORMATION ON THE FACE OF THE ENVELOPE OR THE BID MAY NOT BE CONSIDERED:</p> <p>SEALED BID</p> <p>BUYER: 33</p> <p>RFQ. NO.: 709EC006</p> <p>BID OPENING DATE: 10/22/08 11/12/08</p> <p>BID OPENING TIME: 1:30 P.M.</p> <p>PLEASE PROVIDE A FAX NUMBER IN CASE IT IS NECESSARY TO CONTACT YOU REGARDING YOUR BID:</p> <p style="text-align: center;">----- 304 776 4409 -----</p>						

SEE REVERSE SIDE FOR TERMS AND CONDITIONS		
SIGNATURE	TELEPHONE	DATE
TITLE	FEIN	ADDRESS CHANGES TO BE NOTED ABOVE

WHEN RESPONDING TO RFQ, INSERT NAME AND ADDRESS IN SPACE ABOVE LABELED 'VENDOR'



State of West Virginia
 Department of Administration
 Purchasing Division
 2019 Washington Street East
 Post Office Box 50130
 Charleston, WV 25305-0130

Request for Quotation

RFQ NUMBER
709EC006

PAGE
7

ADDRESS CORRESPONDENCE TO ATTENTION OF
**MICHAEL AUSTIN
 304-558-2402**

VENDOR
 *709054014 304-776-4406
 STATE EQUIPMENT INC
 PO BOX 3939
 CHARLESTON WV 25339

SHIP TO
 DIVISION OF HIGHWAYS
 EQUIPMENT DIVISION
 ROUTE 33
 BRUSHY FORK ROAD
 BUCKHANNON, WV
 26201 304-472-1750

DATE PRINTED	TERMS OF SALE	SHIP VIA	F.O.B.	FREIGHT TERMS
09/23/2008				

BID OPENING DATE: **10/22/2008** BID OPENING TIME **01:30PM**

LINE	QUANTITY	UOP	CAT NO	ITEM NUMBER	UNIT PRICE	AMOUNT
CONTACT PERSON (PLEASE PRINT CLEARLY):						
<i>Jason Lamm</i>						
***** THIS IS THE END OF RFQ 709EC006 ***** TOTAL:						<u>\$98,500.00</u>

SEE REVERSE SIDE FOR TERMS AND CONDITIONS

SIGNATURE		TELEPHONE		DATE
TITLE	FEIN	ADDRESS CHANGES TO BE NOTED ABOVE		

WHEN RESPONDING TO RFQ, INSERT NAME AND ADDRESS IN SPACE ABOVE LABELED 'VENDOR'

WEST VIRGINIA DEPARTMENT OF TRANSPORTATION
DIVISION OF HIGHWAYS
EQUIPMENT DIVISION

PROCUREMENT SPECIFICATIONS
NO. 310-1-D

HYDRAULIC TRACK EXCAVATOR

1.0 PURPOSE

It is the purpose of these specifications to describe a Hydraulic Track Excavator (hereinafter referred to as an "excavator" or a "unit") to be purchased for use by the West Virginia Division of Highways (DOH) on an Open End Contract basis.

2.0 BIDDING PROCEDURES

The current purchasing procedures regarding bidding as established by the Department of Administration, Purchasing Division, shall apply. Failure to submit the "Request for Quotation" forms, complete in its entirety and according to directions indicated, may subject the bidder to disqualification. **Each bid submitted shall also be accompanied by a Bidder's Evaluation Report completed in detail.** Addendums in order, along with exception sheets, should be with Bidder's Evaluation Report. **FAILURE TO SUBMIT THE BIDDER'S EVALUATION REPORT, COMPLETE IN ITS ENTIRETY, MAY RESULT IN AUTOMATIC DISQUALIFICATION.**

3.0 SPECIFICATIONS

The specifications named herein, mandatory and non-mandatory, establish the acceptable level of quality only and are not intended to reflect a preference or favor any particular brand or vendor.

3.1 EXCEPTIONS TO NON-MANDATORY SPECIFICATIONS

Exception to a non-mandatory unit specification may be made by the bidder, providing the exception is not available from the manufacturer. **Any such exception must be noted on the bidder's evaluation report and should be accompanied by supporting documentation/literature from the manufacturer. Any exception must be indicated on a separate attachment to the bidder's evaluation report and labeled as "Exception to Specifications".** The state reserves the right to determine whether the stated exception does or does not reduce the quality and performance of the unit. Failure to provide information for any exceptions may be grounds for rejection of the bid. The state reserves the right to waive minor irregularities in bids or specifications in accordance with §148-1-4(f) of the WV Legislative Rules and Regulations.

3.2 MANDATORY SPECIFICATIONS

All specifications preceded by "shall, will, and/or must" or are stated as a "minimum and/or maximum" are mandatory as stated in Purchasing Divisions Policies and Procedures. Any bid failing to meet any mandatory item shall be immediately disqualified. Failure to respond in the appropriate evaluation section may also be grounds for immediate disqualification at the discretion of the State.

A mandatory pre-bid conference is scheduled for this equipment purchase as stated in the RFQ. Vendors having products with variations or exceptions in specified mandatory items are expected to address any such variations or exceptions during the pre-bid conference. **The State shall review and consider any such variation or exception, and may at its sole discretion, issue an addendum to change mandatory specifications deemed to be in the State's best interest. Bids from any vendor failing to attend the mandatory pre-bid shall be disqualified. Bids containing any variation or exception to a mandatory specification that was not addressed during the pre-bid conference and accepted by the issuance of an Addendum shall be disqualified.**

4.0 REPRESENTATIVE UNIT FOR TEST

The successful vendor must (if specified) provide DOH one (1) completed representative unit to be observed and evaluated on each order to insure compliance with specification. If requested, the time period for testing and evaluation shall be seven (7) working days following receipt of the unit. DOH will incur no obligation for deterioration of surfaces, finishes, seals, and mechanical or electrical parts on the unit resulting from operation and testing within the limits of these specifications; nor will DOH incur obligation for damage to the unit resulting from failure to meet specifications when due care and attention is given by DOH and testing is done within the limits of these specifications. Failure of the pilot unit to satisfactorily meet specifications as bid shall be cause for cancellation of the purchase order, and return of the delivered unit along with all associated equipment to the vendor at the vendor's expense.

4.1 CONDITION OF UNIT(S) UPON DELIVERY

All units must arrive at the prescribed delivery point having been completely preserviced with oil, lubricants, and coolant. All prescribed precautions pertaining to first operations and break-in of the unit are to be posted conspicuously on the unit for ready observance by the operator.

4.2 DELIVERY

Delivery point of the completely assembled representative unit will be the DOH, Equipment Division, Route 33 at Brushy Fork Road, Buckhannon, West Virginia (26201).

The vendor is responsible for guaranteeing delivery of the completed units within the time specified and agreed to by the State. Delivery is preferred within 90 days after receipt of purchase agreement. The vendor is responsible for establishing and coordinating delivery terms with allied manufacturers or suppliers. **Delivery terms shall be stated in the bid and the State reserves the right to accept or negotiate such terms.** Failure to reach an agreement may result in rejection of the bid. **The successful bidder shall provide their manufacturer's confirmation of the order to the WVDOH contact person within seven (7) working days after receiving the approved purchase order.**

A completed pilot model for inspection must be provided within 30 calendar days after receipt of the purchase agreement by the successful vendor.

Delivery is an integral part of this specification and failure to comply will be cause to initiate a D.O.T. Administrative Form WV-82, Vendor Performance Form. The WV-82 Form will provide a means of officially notifying the Purchasing Division and the vendor of unsatisfactory performance; such as late deliveries, poor service, inadequate parts supplies, etc.

The decision to initiate subject Form will be at the sole discretion of the D.O.H. Commissioner's established Equipment Review Board.

Issuance of the WV-82 Vendor Complaint Form on unsatisfactory delivery against any vendor will be cause to refuse to consider similar items from those vendors on future Request For Quotations.

(NOTE: Delivery time could be altered due to labor strikes, severe inclement weather conditions, etc.)

5.0 AWARD CRITERIA

- 5.1 DOH will recommend the award in accordance with the RFQ evaluation criteria described in the requisition. **The award shall be made to the lowest unit cost vendor that meets or exceeds the specifications.**

Prices for the units shall be in quantities of 1-10, 11-20, 21 and over. However, for evaluation purposes, we will use quantities 1-10. DOH reserves the right to place multiple orders in any quantity.

6.0 SPECIFICATIONS AND GUIDELINES - GENERAL

6.1 IDENTIFICATION OF THE UNIT BEING PROPOSED

The bidder must identify the unit by manufacturer, model, series, and year of manufacture, in the bid to enable identification by DOH in the manufacturer's

specifications of the proposed unit. The bidder will submit complete descriptive literature of the proposed unit, to establish that the bid is the manufacturer's most current model, including latest engineering improvements, which have been, or will imminently be, regularly advertised and sold on the open market. The unit specified herein and offered to be manufactured after January 1, 2008 and be clearly identified and marked with date of manufacture.

6.2 OPERATING AND SERVICE MANUALS AND PARTS LISTS

An operator's manual must be included with each unit upon delivery. A "line sheet" (if applicable) and Equipment Preventative Maintenance Questionnaire (as shown in X6.2 of the Bidder's Evaluation Report) must be with pilot unit upon delivery. In addition, there must be 12 service, shop, or maintenance manuals; ten (10) to be distributed to the Districts and two (2) for the Equipment Division. Also, there must be 14 parts manuals; ten (10) to be distributed to the Districts and four (4) for Equipment Division use. CD ROM is preferred in lieu of parts manuals.

*** NOTE: MANUALS SHALL BE DELIVERED UPON COMPLETION OF DELIVERY OF TOTAL UNITS. FAILURE TO DO SO WILL DELAY PAYMENT.**

6.3 TRAINING:

Manufacturers and/or dealers will be required to stage a thorough seminar on the subjects of Preventative Maintenance, Operator and Mechanic Training. **In order to keep the operators and mechanics updated, the successful vendor shall conduct training with each purchase order against this open end contract.** Training is preferred within 2 working days after delivery of the pilot unit on the individual purchase order.

Manufacturers and/or dealers shall be required to furnish the Training Academy with one (1) Operator's Manual to be shipped direct to WVDOH Training Academy, Post Office Box 610, Buckhannon, West Virginia 26201 prior to delivery of the pilot.

The seminar to be held at the W. Va. Division of Highways, Equipment Division, Buckhannon, West Virginia.

6.4 PREVENTIVE MAINTENANCE AND OPERATOR PROCEDURES:

Manufacturers and/or dealers will be required to submit to the Equipment Division, in addition to the operating and service manuals, booklets and pamphlets explaining the Preventive Maintenance and Operator Procedures to be used by the operators of this equipment, and must include such things as daily prestart inspection procedure, service schedule, and routine maintenance required, safety precautions, etc.

The successful vendor shall furnish all training aids; i.e., videos, projectors, etc. required in conducting the training.

6.5 WARRANTY AND SERVICE POLICY

The Manufacturers warranty or service policy is to apply to the unit. Such warranty or service policy is to be recognized at any authorized unit dealer, representing manufacturer of proposed unit throughout the State of West Virginia. The applicable warranty or service policy will not be contingent upon obtaining routine service, lubrication, and servicing of the unit from factory authorized agencies. It will be the responsibility of the bidder to have available labor to repair or replace any defective replacement parts, components and materials, and to have available those replacement parts, components, and/or materials found to be defective during the terms of the warranty period. The bidder should state the labor rates, locations where parts will be stocked, availability of parts, and discounts offered for parts, when terms of the warranty offer a pro-rated cost for parts and labor. In addition, the successful bidder should offer field work to repair or replace defective parts, components, and materials found to be defective during the terms of the warranty and should provide mechanic's travel rates, mileage charges, field mechanic rates, and any surcharge for miscellaneous items, if applicable, for field work during the warranty period. Submit to Division of Highways any technical or engineering improvements during the term of the warranty. **The unit must be accompanied upon delivery by the unit's manufacturer's executed warranty or service policy.**

A mandatory minimum two (2) year bumper to bumper basic parts and labor warranty excluding abuse and normal wear items is required for this unit.

THE "WARRANTY AND SERVICE POLICY QUESTIONNAIRE" ATTACHED IN THE BIDDER'S EVALUATION REPORT MUST BE COMPLETED IN ITS ENTIRETY BY THE SUCCESSFUL BIDDER OR MANUFACTURER PRIOR TO DELIVERY OF THE PILOT MODEL. (SEE SECTION X6.5 OF BIDDER'S EVALUATION REPORT).

6.6 EVALUATION COMMITTEE REQUIREMENTS

Detailed component specifications, product literature, component models, required for specification compliance determination by the Evaluation Committee should be provided with each bid. Any information supplied that is contrary to/or conflicting with the specifications and/or attached Bidders Evaluation Report may be sufficient cause for rejection of bid.

6.7 UNSPECIFIED ACCESSORIES & FEATURES

All parts, equipment, accessories, material, design and performance characteristics not specified herein, but which are necessary to provide a complete unit, must be furnished with each unit and required to conform to strength, quality of material,

and quality of workmanship to those which are advertised and provided to the market in general by the unit industry.

All parts and accessories advertised and regularly supplied as standard shall be included, except those which would represent duplication of these specified, and except those which, by specification, are not to be furnished. All standard safety features, required by Federal and State Law, shall be included.

7.0 SPECIFICATIONS OF THE QUOTED UNIT ARE AS FOLLOWS:

Shall be Kobelco SK135SR or equal

7.1 Operating weight shall be no less than 28,000 pounds and not more than 32,291 pounds.

7.2 Engine:

7.2.1 Engine will be 84 horsepower minimum.

7.2.2 Engine should be turbocharged diesel.

7.2.3 Pressurized liquid cooling system with thermostat, filled with manufacturers approved extended life permanent type anti-freeze that provides freeze protection to at least -30 degrees F.

7.2.4 Air cleaner, double element with auto dust evacuation.

7.2.5 Fuel filtering system shall be manufacturer's heaviest duty available.

7.2.6 Dust proof net for radiator and oil cooler should be provided.

7.2.7 Manufacturer's heaviest duty electrical system shall be provided.

7.3 Hydraulic System:

7.3.1 Hydraulic system to maintain manufacturers recommended safe oil temperature within recommended operating range during continuous operation under maximum working combinations.

7.3.2 System to have manufacturer's heaviest variable capacity piston type pumps with load sensing for maximum efficiency.

7.3.3 Boom length should be no less then 15 feet and controlled by two (2) hydraulic cylinders.

- 7.3.4 Arm length should be no less than 8 feet and controlled by one (1) hydraulic cylinder and equipped with multi function hydraulics with piping to the end of arm with foot controls.
- 7.3.5 Shut off valve at end of piping.
- 7.3.5.1 **Unit shall be equipped with a hydraulic thumb approximately 18 inches x 46 inches.**
- 7.3.5.2 Tine thickness of thumb to be 1 inch with a pin diameter of approximately 2 inches.
- 7.3.6 Bucket to be approximately 0.60 cubic yard capacity, **shall be with teeth and side cutters and controlled by one (1) hydraulic cylinder.**
- 7.3.7 **Drive shall be hydrostatic design with independent track control.**
- 7.3.8 Wet multiple disk brakes that automatically release while propelling and apply when stationary.
- 7.3.9 **Unit swing shall be capable of 360 degrees.**
- 7.3.10 Swing speed should be approximately 10 R.P.M.
- 7.3.11 **Swing brake shall be SAHR for safety.**
- 7.3.12 **Unit shall be joystick controlled with one (1) additional actuator for auxiliary hydraulics.**
- 7.4 Undercarriage:
- 7.4.1 **Undercarriage frame shall be manufacturers standard for model bid.**
- 7.4.2 **Unit shall have sealed type track.**
- 7.4.3 **A minimum of one (1) top carrier roller each side for proper track support.**
- 7.4.4 **Track guides shall be provided to prevent track misalignment.**
- 7.4.5 **Track adjustment shall be of hydraulic design.**
- 7.4.6 Manufacturers triple grouser shoes.
- 7.4.7 Track length approximately 11 feet 6 inches.

7.4.8 **Maximum tail swing 4.82 feet including manufacturers needed weight(s)**

7.5 Cab:

7.5.1 **Cab shall be all weather steel isolation mounted.**

7.5.2 **Unit will have a deep cushioned fully adjustable seat with padded arm rests.**

7.5.3 **Cab shall be equipped manufacturers heater and air condition system.**

7.5.4 **Cold weather starting aid shall be provided.**

7.5.5 Cab equipped with front windshield wiper and washer, intermittent features.

7.5.6 **Manufacturers vandalism protection package shall be provided.**

7.5.7 Interior cab light.

7.5.8 Work lights at boom and cab for sufficient night shift operations.

7.5.9 Tinted safety glass at all locations.

7.5.10 AM and FM radio with antenna.

7.6 Paint:

7.6.1 **Unit will be painted manufacturers standard color.**

7.6.2 Manufacturers standard plant painting procedures for cleaning, degreasing, preparing, priming and painting are sufficient to meet the requirements for painting unit.

7.7 **Vendor must certify that unit offered will meet or exceed the "Occupational Safety and Health Act or 1970" and subsequent amendments.**

7.8 Advertising: No visible decals or name plates or painted on names representing the manufacturer or model number or trademark should appear on the exterior surface of the unit. Such logos created through the stamping or casting process of manufacture are accepted.

WEST VIRGINIA DEPARTMENT OF TRANSPORTATION
DIVISION OF HIGHWAYS
EQUIPMENT DIVISION

BIDDER'S EVALUATION REPORT

PROCUREMENT SPECIFICATIONS FOR OPEN END CONTRACT
NO. 310-1-D

HYDRAULIC TRACK EXCAVATOR

NOTE TO BIDDER: Procurement Specification No. 310-1-D, Paragraph 2.0 recommends the completion and submittal of this Report with your bid. Purpose of this Report is to enable the West Virginia Division of Highways Evaluation Committee to make full and fair evaluation of the bid. Addendums in order, along with a summary of exception as a separate attachment, should be with Bidder's Evaluation Report. FAILURE TO SUBMIT THIS REPORT, COMPLETE IN ITS ENTIRETY, MAY SUBJECT THE BIDDER TO DISQUALIFICATION.

Reference Requisition No.: 709EC006

Bidder's Name: State Equipment Inc.

Address: 560 New Goff Mtn. Rd. Cross Lanes, WV 25313

Telephone Number: 304 774 4405

Years Bidder has been registered to do business with the State of West Virginia: 23 YRS.

Years Company has been an authorized dealer for proposed unit: 23 YRS.

X3.2 Have you complied with all mandatory specifications? YES NO

X4.2 DELIVERY:

X4.2.1 Delivery date of completed representative unit: 60 Calendar Days After
Receipt of Purchase Agreement

X4.2.2 Delivery date of balance of completed units: 90-120 Calendar Days After Receipt of
Purchase Agreement

X5.0 AWARD CRITERIA;

X5.1 Prices for units:

1-10	<u>\$ 98,500.00</u> per unit
11-20	<u>\$ 98,500.00</u> per unit
21 and over	<u>\$ 98,500.00</u> per unit

X6.0 SPECIFICATIONS - GENERAL

X6.1 Manufacturer, model, series, and date of manufacture of proposed unit:

2009 Case CX135

Is descriptive literature, fully describing proposed unit attached to your bid? YES NO

If not, why? _____

X6.2 Will the required number of service manuals, and complete parts list be delivered to the Equipment Division at Buckhannon upon completion of delivery of total units?

YES NO

Will the required Equipment Preventive Maintenance Form (Section X6.2 of Bidders Evaluation Report) be provided upon inspection of the pilot unit?

YES NO

X6.2
2-10-00

EQUIPMENT PREVENTATIVE MAINTENANCE QUESTIONNAIRE

THIS FORM MUST BE COMPLETED IN ITS ENTIRETY BY SUCCESSFUL BIDDER OR MANUFACTURER'S TECHNICAL REPRESENTATIVE PRIOR TO DELIVERY OF PILOT MODEL TO THE WVD0H.

DESCRIPTION: _____ MAKE: _____

MODEL: _____ YEAR: _____ PURCHASE AMOUNT: _____

ENGINE: MAKE: _____ MODEL: _____ FUEL TYPE: _____

HORSEPOWER: _____ CYLINDER: _____ ENGINE SERIAL: _____

COOLING SYSTEM CAPACITY: _____

BELTS: DESCRIPTION: _____ PART NUMBERS: _____

GVW: _____ AXLE CAPACITY: FRONT: _____ REAR: _____

TIRES: FRONT MAKE & SIZE: _____

REAR MAKE & SIZE: _____

DIMENSIONS OF UNIT: LENGTH: _____ WIDTH: _____ LENGTH: _____

VENDOR CONTACT PERSON: _____ PHONE: _____

PARTS:

BATTERY MAKE: _____ MODEL: _____ CCA: _____

TOP OR SIDE POST: _____ DIMENSIONS: LENGTH _____ WIDTH _____ HEIGHT _____

SPARK PLUGS OR FUEL INJECTORS MAKE: _____ PART # _____

FUEL PUMP OR INJECTION PUMP MAKE: _____ MODEL: _____

ALTERNATOR MAKE: _____ PART #: _____

STARTER MAKE: _____ PART #: _____

TURBO CHARGER MAKE: _____ PART #: _____

TRANS. MAKE: _____ MODEL: _____ AUTO/MANUAL: _____

HYDRAULIC PUMP MAKE: _____ MODEL: _____

FILTERS	MAKE	PART NO.	LUBRICANT	MANUFACTURER TYPE
OIL	_____	_____	ENGINE	_____
AIR INNER	_____	_____	TRANSMISSION	_____
AIR OUTER	_____	_____	POWER STEERING	_____
FUEL PRIMARY	_____	_____	HYDRAULIC	_____
FUEL SECONDARY	_____	_____	DIFFERENTIALS	_____
COOLANT	_____	_____	BRAKE FLUID	_____
HYDRAULIC	_____	_____	COOLANT	_____
OTHER	_____	_____	OTHER	_____

X6.3 TRAINING:

Will training seminar be conducted on Preventive Maintenance, Operator and Mechanic Training YES NO

Will you conduct training with each purchase order against this open end contract? YES NO

Will training be conducted within 2 working days from the delivery of the pilot unit on the individual purchase order? YES NO

If NO, explain time frame _____

Will an Operator's Manual be furnished directly to Training Academy prior to the delivery of the pilot? YES NO

X6.4 If you are the successful vendor, will you furnish all training aids, i.e., videos, projectors, required in conducting the training? YES NO

X6.4.1 Will all manuals, booklets, etc. explaining preventive maintenance, operator procedures, and service schedule be delivered with each unit? YES NO

If NO, explain _____

X6.5 WARRANTY AND SERVICE POLICY

Will the warranty and service you provide comply with all areas as stated in Section 6.5 of specifications YES NO

Is warranty literature attached? YES NO

Is a minimum two (2) year bumper to bumper basic parts and labor warranty excluding abuse and normal wear items included? YES NO

Describe:

Full Machine 2yr 2400 hr 0 deductible
Excluding normal wear + normal maintenance

X6.5 WARRANTY AND SERVICE POLICY QUESTIONNAIRE
THIS FORM MUST BE COMPLETED IN ITS ENTIRETY AND SUBMITTED WITH YOUR BID.

(If additional lines are needed, make copies of form.)

1. Define the terms of the standard warranty. If not offered, so state. (Attach copy)

Full Machine 2yr 2400 hr. 0 deductible
Excluding normal wear and normal maintenance

2. Define warranty service to be performed at DOH facilities and warranty service to be performed at manufacturer's representative facility. List name and location of manufacturer's representative.

All warranty work to be performed at dealer locations
Charleston WV, Bridgeport WV, Beckley WV, Parkersburg WV,
Ashland KY

3. List locations for parts inventories that are within the State of West Virginia. Also, list availability levels, if known.

Bridgeport, WV, Parkersburg WV, Charleston WV, Beckley, WV

4. During the term of warranty, list the guarantee discount to manufacturer's published list price for parts that bidder will sell the parts to owner.

- A. Terms: Net 30 Manufacturer's published list price less: 0 % discount
- B. Terms: Net 60 Manufacturer's published list price less: 0 % discount
- C. Terms: Net 90 Manufacturer's published list price less: 0 % discount

5. During the term of warranty, will all manufacturers or engineering improvements be submitted to Division of Highways? YES NO

6. During the term of warranty, list the guaranteed rates charged for repair to the unit.

- A. Shop Rate \$ 90.00 per mechanic hour
- B. Travel Time Charge \$ 90.00 per mechanic hour
(Specify if one-way) _____; port to port
- C. Mileage Charge \$ 2.15 per vehicle mile
(Specify if one-way) _____; port to port
- D. Field Mechanic Rate \$ 90.00 per mechanic hour
- E. Specify period of time that prices are in effect: 1 year
- F. Surcharge for miscellaneous items: 2 %

X6.6 EVALUATION COMMITTEE REQUIREMENTS

Is all component specifications, product literature, component models provided for Evaluation Committee bid determination? YES NO

X6.7 Will all parts, equipment, accessories, material, design and performance characteristics not specified herein, but which are necessary to provide a complete unit, be furnished with the unit and conform in strength, quality of material, and quality of workmanship to those which are advertised and provided to the market in general by the unit industry? YES NO

X6.7.1 Are all parts and accessories adequate and regularly supplied as standard to be included except those which may be duplications of specifications herein, and except these by specification are not to be furnished? YES NO

X6.7.2 Are all standard safety features that are required by Federal and State statutes of law included? YES NO

X7.0 SPECIFICATIONS OF THE QUOTED UNIT:

The bidder should complete the following schedule in order for the Division to compare the actual bid unit to the specifications. Should the bidder except a requirement, then such exception may be only on the basis that such feature is not offered by the manufacturer. The Division will have the sole discretion as to whether the bidder's substitution meets the requirements of the specification.

Manufacturer: Case Model: CX135

X7.1 Specify operating weight 30,767 pounds.

X7.2 Engine:

X7.2.1 Specify engine 95 HP.

X7.2.2 Is engine turbocharged diesel? YES NO

X7.2.3 Is pressurized liquid cooling system w/thermostat, filled with manufacturers approved extended life permanent type anti-freeze that provides freeze protection to at least -30° F? YES NO

ADD: To Bidder's Evaluation Report

X7.2.4 Is air cleaner, double element with auto dust evacuation? YES ___ NO

X7.2.5 Is fuel filtering system manufacturers heaviest duty available? YES ___ NO

X7.2.6 Is dust proof net for radiator and oil cooler provided? YES ___ NO

X7.2.7 Will Manufacturers heaviest duty electrical system be provided?
 YES ___ NO

X7.3 Hydraulic System:

X7.3.1 Will proposed hydraulic system maintain manufacturers recommended safe oil temperature within recommended operating range during continuous operation under maximum working combinations? YES ___ NO

X7.3.2 Does system provide manufacturer heaviest variable capacity piston type pumps With load sensing for maximum efficiency? YES ___ NO

X7.3.3 Is boom controlled by two (2) hydraulic cylinders? YES ___ NO
Specify boom length 15'6" feet

X7.3.4 Is arm controlled by one (1) hydraulic cylinder/equipped with multi function hydraulic with piping to the end of arm with foot controls? YES ___ NO
Specify arm length 9'4" feet

X7.3.5 Is shut off valve at end of piping? YES ___ NO

X7.3.5.1 Is unit equipped with a hydraulic thumb? YES ___ NO
Specify size 18 inches x 50 inches

X7.3.5.2 Tine thickness of thumb 1 inch with a pin diameter 2 inch

X7.3.6 Bucket 73 cubic yard with teeth and side cutters YES ___ NO

Controlled by one (1) hydraulic cylinder YES ___ NO

X7.3.7 Is drive hydrostatic design with independent track control? YES ___ NO

ADD: To Bidder's Evaluation Report

X7.3.8 Does unit have wet multiple disk brakes that automatically releases while propelling and applies when stationary? YES NO

X7.3.9 Is unit swing capable of 360 degrees? YES NO

X7.3.10 Specify swing speed 10 R.P.M.

X7.3.11 Is swing brake SAHR for safety? YES NO

If not specify: _____

X7.3.12 Is unit joystick controlled with one (1) additional actuator for auxiliary hydraulics? YES NO

X7.4 Undercarriage:

X7.4.1 Is undercarriage frame manufacturers standard for model bid? YES NO

X7.4.2 Does unit have sealed type track YES NO

X7.4.3 Does unit have a minimum of one (1) top carrier roller each side for proper track support YES NO

X7.4.4 Are track guides provided to prevent track misalignment YES NO

X7.4.5 Is track adjustment of hydraulic design YES NO

X7.4.6 Does unit have manufacturers triple grouser shoes? YES NO

X7.4.7 Specify track length 11 feet 6 inches

X7.4.8 Tail Swing including manufacturers needed weight(s): 4'10" feet

X7.5 Cab:

X7.5.1 Is proposed cab all weather steel isolation mounted? YES NO

X7.5.2 Does proposed unit have a deep cushioned fully adjustable seat with padded arm rests? YES NO

X7.5.3 Is cab equipped with manufacturers heater and air condition system? YES NO

X7.5.4 Is cold weather starting aid provided? YES NO

- X7.5.5 Is cab equipped with front windshield wiper/washer with intermittent features? YES NO
- X7.5.6 Is manufacturers vandalism protection package provided? YES NO
- X7.5.7 Is unit provided with interior cab light? YES NO
- X7.5.8 Are work lights provided at boom and cab adequate for night shift operations? YES NO
- X7.5.9 Is tinted safety glass provided at all locations? YES NO
- X7.5.10 Is AM/FM radio with antenna provided? YES NO
- X7.6 Paint:
- X7.6.1 Will unit be painted manufacturers standard color? YES NO
- X7.6.2 Does painting procedures for cleaning, degreasing, preparing, priming/painting meet manufacturers standard requirement for painting unit? YES NO
- X7.7 Does unit meet OSHA requirements as specified? YES NO
- X7.8 Does unit meet advertising guidelines as specified? YES NO

VENDOR PREFERENCE CERTIFICATE

Certification and application* is hereby made for Preference in accordance with West Virginia Code, §5A-3-37. (Does not apply to construction contracts). West Virginia Code, §5A-3-37, provides an opportunity for qualifying vendors to request (at the time of bid) preference for their residency status. Such preference is an evaluation method only and will be applied only to the cost bid in accordance with the West Virginia Code. This certificate for application is to be used to request such preference. The Purchasing Division will make the determination of the Resident Vendor Preference, if applicable.

- 1. Application is made for 2.5% resident vendor preference for the reason checked: Bidder is an individual resident vendor and has resided continuously in West Virginia for four (4) years immediately preceding the date of this certification; or, Bidder is a partnership, association or corporation resident vendor and has maintained its headquarters or principal place of business continuously in West Virginia for four (4) years immediately preceding the date of this certification; or 80% of the ownership interest of Bidder is held by another individual, partnership, association or corporation resident vendor who has maintained its headquarters or principal place of business continuously in West Virginia for four (4) years immediately preceding the date of this certification; or, Bidder is a nonresident vendor which has an affiliate or subsidiary which employs a minimum of one hundred state residents and which has maintained its headquarters or principal place of business within West Virginia continuously for the four (4) years immediately preceding the date of this certification; or,
2. Application is made for 2.5% resident vendor preference for the reason checked: Bidder is a resident vendor who certifies that, during the life of the contract, on average at least 75% of the employees working on the project being bid are residents of West Virginia who have resided in the state continuously for the two years immediately preceding submission of this bid; or,
3. Application is made for 2.5% resident vendor preference for the reason checked: Bidder is a nonresident vendor employing a minimum of one hundred state residents or is a nonresident vendor with an affiliate or subsidiary which maintains its headquarters or principal place of business within West Virginia employing a minimum of one hundred state residents who certifies that, during the life of the contract, on average at least 75% of the employees or Bidder's affiliate's or subsidiary's employees are residents of West Virginia who have resided in the state continuously for the two years immediately preceding submission of this bid; or,
4. Application is made for 5% resident vendor preference for the reason checked: Bidder meets either the requirement of both subdivisions (1) and (2) or subdivision (1) and (3) as stated above; or,
5. Application is made for 3.5% resident vendor preference who is a veteran for the reason checked: Bidder is an individual resident vendor who is a veteran of the United States armed forces, the reserves or the National Guard and has resided in West Virginia continuously for the four years immediately preceding the date on which the bid is submitted; or,
6. Application is made for 3.5% resident vendor preference who is a veteran for the reason checked: Bidder is a resident vendor who is a veteran of the United States armed forces, the reserves or the National Guard, if, for purposes of producing or distributing the commodities or completing the project which is the subject of the vendor's bid and continuously over the entire term of the project, on average at least seventy-five percent of the vendor's employees are residents of West Virginia who have resided in the state continuously for the two immediately preceding years.

Bidder understands if the Secretary of Revenue determines that a Bidder receiving preference has failed to continue to meet the requirements for such preference, the Secretary may order the Director of Purchasing to: (a) reject the bid; or (b) assess a penalty against such Bidder in an amount not to exceed 5% of the bid amount and that such penalty will be paid to the contracting agency or deducted from any unpaid balance on the contract or purchase order.

By submission of this certificate, Bidder agrees to disclose any reasonably requested information to the Purchasing Division and authorizes the Department of Revenue to disclose to the Director of Purchasing appropriate information verifying that Bidder has paid the required business taxes, provided that such information does not contain the amounts of taxes paid nor any other information deemed by the Tax Commissioner to be confidential.

Under penalty of law for false swearing (West Virginia Code, §61-5-3), Bidder hereby certifies that this certificate is true and accurate in all respects; and that if a contract is issued to Bidder and if anything contained within this certificate changes during the term of the contract, Bidder will notify the Purchasing Division in writing immediately.

Bidder: State Equipment, Inc Signed: [Signature]
Date: 10/27/08 Title: Vice President

*Check any combination of preference consideration(s) indicated above, which you are entitled to receive.

STATE OF WEST VIRGINIA
Purchasing Division

PURCHASING AFFIDAVIT

VENDOR OWING A DEBT TO THE STATE:

West Virginia Code §5A-3-10a provides that: No contract or renewal of any contract may be awarded by the state or any of its political subdivisions to any vendor or prospective vendor when the vendor or prospective vendor or a related party to the vendor or prospective vendor is a debtor and the debt owed is an amount greater than one thousand dollars in the aggregate.

PUBLIC IMPROVEMENT CONTRACTS & DRUG-FREE WORKPLACE ACT:

West Virginia Code §21-1D-5 provides that: Any solicitation for a public improvement construction contract shall require each vendor that submits a bid for the work to submit at the same time an affidavit that the vendor has a written plan for a drug-free workplace policy in compliance with Article 1D, Chapter 21 of the West Virginia Code. A public improvement construction contract may not be awarded to a vendor who does not have a written plan for a drug-free workplace policy in compliance with Article 1D, Chapter 21 of the West Virginia Code and who has not submitted that plan to the appropriate contracting authority in timely fashion. For a vendor who is a subcontractor, compliance with Section 5, Article 1D, Chapter 21 of the West Virginia Code may take place before their work on the public improvement is begun.

ANTITRUST:

In submitting a bid to any agency for the state of West Virginia, the bidder offers and agrees that if the bid is accepted the bidder will convey, sell, assign or transfer to the state of West Virginia all rights, title and interest in and to all causes of action it may now or hereafter acquire under the antitrust laws of the United States and the state of West Virginia for price fixing and/or unreasonable restraints of trade relating to the particular commodities or services purchased or acquired by the state of West Virginia. Such assignment shall be made and become effective at the time the purchasing agency tenders the initial payment to the bidder.

I certify that this bid is made without prior understanding, agreement, or connection with any corporation, firm, limited liability company, partnership or person or entity submitting a bid for the same materials, supplies, equipment or services and is in all respects fair and without collusion or fraud. I further certify that I am authorized to sign the certification on behalf of the bidder or this bid.

LICENSING:

Vendors must be licensed and in good standing in accordance with any and all state and local laws and requirements by any state or local agency of West Virginia, including, but not limited to, the West Virginia Secretary of State's Office, the West Virginia Tax Department, West Virginia Insurance Commission, or any other state agencies or political subdivision. Furthermore, the vendor must provide all necessary releases to obtain information to enable the Director or spending unit to verify that the vendor is licensed and in good standing with the above entities.

CONFIDENTIALITY:

The vendor agrees that he or she will not disclose to anyone, directly or indirectly, any such personally identifiable information or other confidential information gained from the agency, unless the individual who is the subject of the information consents to the disclosure in writing or the disclosure is made pursuant to the agency's policies, procedures and rules. Vendors should visit www.state.wv.us/admin/purchase/privacy for the Notice of Agency Confidentiality Policies.

Under penalty of law for false swearing (*West Virginia Code* §61-5-3), it is hereby certified that the vendor acknowledges the information in this said affidavit and is in compliance with the requirements as stated.

Vendor's Name: State Equipment Inc.

Authorized Signature:  Date: 10/27/08



CX135

**EXCAVATOR
TIER III CERTIFIED**

ENGINE

Model	Isuzu AJ-4JJ1X, Tier III certified
Type	4-stroke, turbocharged
Cylinders	4
Bore/Stroke	3.76 in x 4.13 in (95.4 x 104.9 mm)
Displacement	183 in ³ (2999 cc)
Fuel Injection	Direct
Fuel injection pump	Electronic
Fuel	Diesel
Fuel filter	In-line strainer
Cooling	Liquid
Horsepower per SAE J1349	
Net	95 hp (70.9 kW) @ 2000 rpm
Maximum torque @ 1600 rpm	
Net	265 lb-ft (359 N·m)

BOOM/ARM

Boom 15 ft 6 in (4.73 m)	
Boom w/arm cylinder & plumbing	2,147 lb (974 kg)
Hoist cylinders(2)	269 lb (122 kg) ea
Total weight	2,686 lb (1218 kg)
9 ft 4 in Arm (2.85 m)	
Bare arm	853 lb (387 kg)
Bucket cylinder linkage & plumbing	479 lb (217 kg)
Total weight	1,332 lb (604 kg)
7 ft 10 in Arm (2.39 m)	
Bare arm	669 lb (304 kg)
Bucket cylinder linkage & plumbing	479 lb (217 kg)
Total weight	1,148 lb (521 kg)

UNDERCARRIAGE

Number of top rollers	
Top, each track	1
Bottom, each track	6
Number of shoes	
Triple grouser – each track	43
Link pitch	6.75 in (171.5 mm)
Gradeability	70%

HYDRAULICS

Pumps (2)	Variable displacement axial piston design
Capacity –	
Maximum	2 x 31.0 gpm (117.2 L/min)
System relief pressure –	
Standard	4,975 psi (34.3 MPa)
Control valves –	
1-spool blade (optional)	
4-spool section for left track travel, boom, bucket and arm	
5-spool section for right track travel, boom, auxiliary, swing and arm	
Boom and arm anti-drift valves	
Pilot control hydraulic system –	
Pump (1)	Gear design
Maximum capacity	5.3 gpm (20 L/min)
Relief pressure	566 psi (3.9 MPa)
Swing –	
Motor (1)	Fixed displacement axial piston design
Speed	0-10.0 rpm
Brake	Mechanical disc
Travel –	
Motor (2)	Two-speed axial piston design
Final drive	Planetary gear reduction
Drawbar pull	25,853 lb (115 kN)
Travel Speeds – 2	
Auto shift high to low	
	Forward/Reverse
Low	1.9 mph (3.1 km/h)
High	3.1 mph (5.0 km/h)
Travel control valve –	
Dual stage relief and counter-balance design	

HYDRAULIC CYLINDERS

Boom cylinders (2) –	
Bore diameter	4.1 in (105 mm)
Rod diameter	3.0 in (75 mm)
Stroke	44.1 in (1120 mm)
Arm cylinder (1) –	
Bore diameter	4.5 in (115 mm)
Rod diameter	3.1 in (80 mm)
Stroke	43.6 in (1108 mm)
Bucket cylinder (1) –	
Bore diameter	3.7 in (95 mm)
Rod diameter	2.6 in (65 mm)
Stroke	34.7 in (881 mm)

ELECTRICAL

Voltage	24 volts, negative ground
Alternator	50 amp
Batteries (2)12V	Low-maintenance 72 Ah (5 hr rate)

SERVICE CAPACITIES

Hydraulic tank	
Refill capacity	21 gal (81 L)
Total system	34 gal (130 L)
Final drive (per side)	2.2 qt (2.1 L)
Swing drive	3.2 qt (3.0 L)
Engine	
w/filter change	18.2 qt (17.2 L)
Fuel	44 gal (165 L)
Radiator	14.9 qt (14.1 L)

OPERATING WEIGHT

With 7 ft 10 in (2.39 m) arm, 23.6 in (600 mm) track shoes, 750 lb (340 kg) bucket, 165 lb (75 kg) operator, full fuel and standard equipment 29,631 lb (13 440 kg)

LIFT CAPACITIES

9 ft 4 in (2.85 m) Arm Lift capacities calculated using a 750 lb (340 kg) bucket and 7,099 lb (3220 kg) counterweight in "Standard" Mode.

Load (Lift Point) Height	5 ft (1.52 m)		10 ft (3.05 m)		15 ft (4.57 m)		20 ft (6.1 m)		25 ft (7.62 m)		MAXIMUM REACH			
	END	SIDE	END	SIDE	END	SIDE	END	SIDE	END	SIDE	@	END	SIDE	
+25 ft (7.62 m)												18 ft 3 in (5.56 m)	3,750 lb* (1701 kg)*	3,750 lb* (1701 kg)*
+20 ft (6.1 m)					6,750 lb* (3062 kg)*	6,750 lb* (3062 kg)*						23 ft 0 in (7.01 m)	3,350 lb* (1520 kg)*	3,350 lb* (1520 kg)*
+15 ft (4.57 m)					7,600 lb* (3447 kg)*	7,350 lb* (3334 kg)*	6,300 lb (2858 kg)	4,450 lb (2018 kg)				25 ft 8 in (7.82 m)	3,200 lb* (1451 kg)*	2,800 lb* (1270 kg)*
+10 ft (3.05)			11,700 lb* (5307 kg)*	11,700 lb* (5307 kg)*	9,550 lb* (4332 kg)*	7,000 lb (3175 kg)	6,100 lb (2767 kg)	4,300 lb (1950 kg)				27 ft 0 in (8.23 m)	3,300 lb* (1497 kg)*	2,400 lb (1089 kg)
+5 ft (1.52 m)			17,750 lb* (8051 kg)*	12,150 lb (5511 kg)	9,300 lb (4218 kg)	6,400 lb (2903 kg)	5,800 lb (2631 kg)	4,000 lb (1814 kg)	4,000 lb (1817 kg)	2,700 lb (1255 kg)		27 ft 3 in (8.31 m)	3,450 lb (1565 kg)	2,300 lb (1043 kg)
Ground- line			17,450 lb (7915 kg)	10,900 lb (4944 kg)	8,750 lb (3969 kg)	5,850 lb (2654 kg)	5,550 lb (2517 kg)	3,750 lb (1701 kg)	3,900 lb (1769 kg)	2,600 lb (1179 kg)		26 ft 5 in (8.05 m)	3,550 lb (1610 kg)	2,350 lb (1066 kg)
-5 ft (-1.52 m)	10,800 lb* (4899 kg)*	10,800 lb* (4899 kg)*	17,000 lb (7711 kg)	10,600 lb (4808 kg)	8,450 lb (3833 kg)	5,600 lb (2540 kg)	5,400 lb (2449 kg)	3,600 lb (1633 kg)				24 ft 5 in (7.44 m)	4,000 lb (1814 kg)	2,650 lb (1202 kg)
-10 ft (-3.05 m)	16,550 lb* (7507 kg)*	18,550 lb* (7507 kg)*	17,000 lb (7711 kg)	10,700 lb (4853 kg)	8,400 lb (3810 kg)	5,500 lb (2517 kg)	5,400 lb (2449 kg)	3,600 lb (1633 kg)				20 ft 10 in (6.35 m)	5,200 lb (2359 kg)	3,500 lb (1588 kg)
-15 ft (-4.57 m)	18,600 lb* (8437 kg)*	18,600 lb* (8437 kg)*	12,050 lb* (5466 kg)*	10,950 lb* (4967 kg)	7,900 lb* (3583 kg)*	5,800 lb (2631 kg)								

7 ft 10 in (2.39 m) Arm Lift capacities calculated using a 750 lb (340 kg) bucket and 7,099 lb (3220 kg) counterweight in "Standard" Mode.

Load (Lift Point) Height	5 ft (1.52 m)		10 ft (3.05 m)		15 ft (4.57 m)		20 ft (6.1 m)		MAXIMUM REACH				
	END	SIDE	END	SIDE	END	SIDE	END	SIDE	@	END	SIDE		
+25 ft (7.62 m)										16 ft 4 in (4.98 m)	3,565 lb* (1617 kg)*	3,565 lb* (1617 kg)*	
+20 ft (6.1 m)					6,965 lb* (3159 kg)*	6,965 lb* (3159 kg)*					21 ft 6 in (6.55 m)	3,065 lb* (1390 kg)*	3,065 lb* (1390 kg)*
+15 ft (4.57 m)					8,765 lb* (3976 kg)*	7,349 lb (3333 kg)	6,249 lb (2834 kg)	4,449 lb (2018 kg)			24 ft 4 in (7.42 m)	2,915 lb* (1322 kg)*	2,915 lb* (1322 kg)*
+10 ft (3.05)			14,265 lb* (6470 kg)*	13,499 lb (6123 kg)	9,899 lb (4490 kg)	6,899 lb (3129 kg)	6,099 lb (2766 kg)	4,299 lb (1950 kg)			25 ft 9 in (7.85 m)	2,915 lb* (1322 kg)*	2,699 lb (1224 kg)
+5 ft (1.52 m)			18,459 lb (8414 kg)	11,849 lb (5375 kg)	9,249 lb (4195 kg)	6,349 lb (2880 kg)	5,849 lb (2653 kg)	4,049 lb (1837 kg)			26 ft 0 in (7.92 m)	3,115 lb* (1413 kg)*	2,549 lb (1156 kg)
Ground- line			17,299 lb (7847 kg)	10,889 lb (4944 kg)	8,799 lb (3991 kg)	5,899 lb (2676 kg)	5,649 lb (2562 kg)	3,849 lb (1746 kg)			25 ft 2 in (7.67 m)	3,465 lb* (1572 kg)*	2,649 lb (1202 kg)
-5 ft (-1.52 m)	11,515 lb* (5223 kg)*	11,515 lb* (5223 kg)*	17,249 lb (7824 kg)	10,799 lb (4898 kg)	8,549 lb (3878 kg)	5,699 lb (2585 kg)	5,499 lb (2494 kg)	3,749 lb (1701 kg)			23 ft 1 in (7.04 m)	4,115 lb* (1866 kg)*	3,049 lb (1383 kg)
-10 ft (-3.05 m)	18,465 lb* (8376 kg)*	18,465 lb* (8376 kg)*	16,365 lb* (7423 kg)*	10,999 lb (4898 kg)	8,599 lb (3900 kg)	5,749 lb (2608 kg)					19 ft 2 in (5.84 m)	5,565 lb* (2524 kg)*	4,149 lb (1882 kg)
-15 ft (-4.57 m)			9,665 lb* (4384 kg)*	9,665 lb* (4384 kg)*									

NOTE: *Lift capacities do not exceed 75% of the minimum tipping load or 87% of the hydraulic lift capacity.
Capacities that are marked with an asterisk are hydraulic limited.

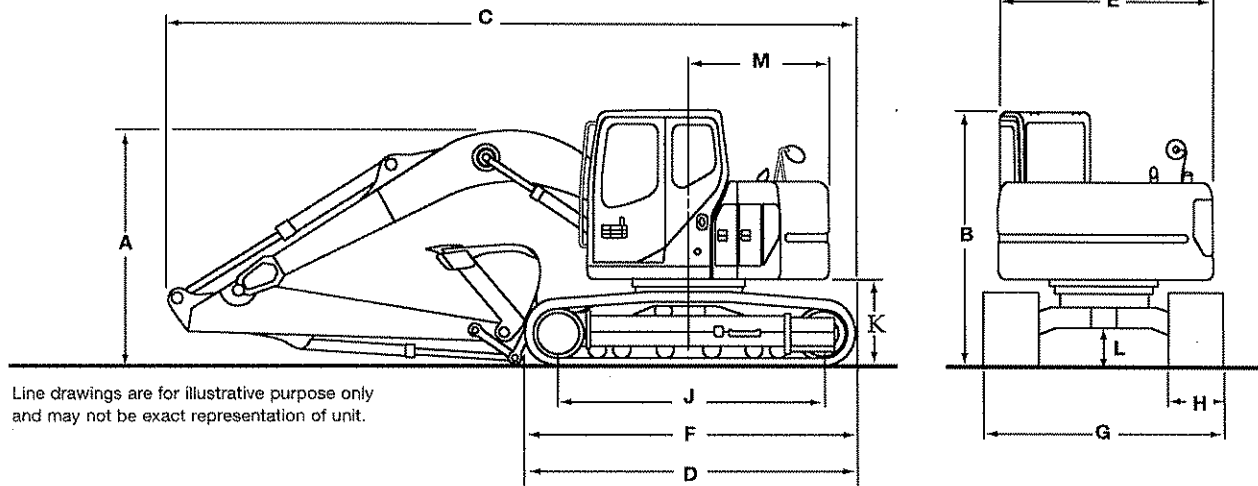

DIMENSIONS

	9 ft 4 in (2.85 m) Arm	7 ft 10 in (2.39 m) Arm
A. Overall height	9 ft 0 in (2.75 m)	9 ft 0 in (2.75 m)
B. Cab height	9 ft 0 in (2.75 m)	9 ft 0 in (2.75 m)
C. Overall length	23 ft 9 in (7.23 m)	23 ft 9 in (7.23 m)
D. w/o attachment	11 ft 6 in (3.51 m)	11 ft 6 in (3.51 m)
E. Width of upperstructure	7 ft 11 in (2.42 m)	7 ft 11 in (2.42 m)
F. Track overall length	11 ft 6 in (3.51 m)	11 ft 6 in (3.51 m)
G. Track overall width w/23.6 in (600 mm) shoes	8 ft 6 in (2.59 m)	8 ft 6 in (2.59 m)
H. Track shoe width	23.6 in (600 mm)	23.6 in (600 mm)
J. Center to center (idler to sprocket)	9 ft 2 in (2.79 m)	9 ft 2 in (2.79 m)
K. Upperstructure ground clearance	2 ft 11 in (0.88 m)	2 ft 11 in (0.88 m)
L. Minimum ground clearance	1 ft 5 in (0.44 m)	1 ft 5 in (0.44 m)
M. Tail swing radius	4 ft 10 in (1.48 m)	4 ft 10 in (1.48 m)
Working weight*	29,814 lb (13 523 kg)	29,631 lb (13 440 kg)
Ground pressure	5.3 psi (36 kPa)	5.3 psi (36 kPa)

*With 23.6 in (600 mm) track shoe, 750 lb (340 kg) bucket, 165 lb (75 kg) operator, full fuel and standard equipment.

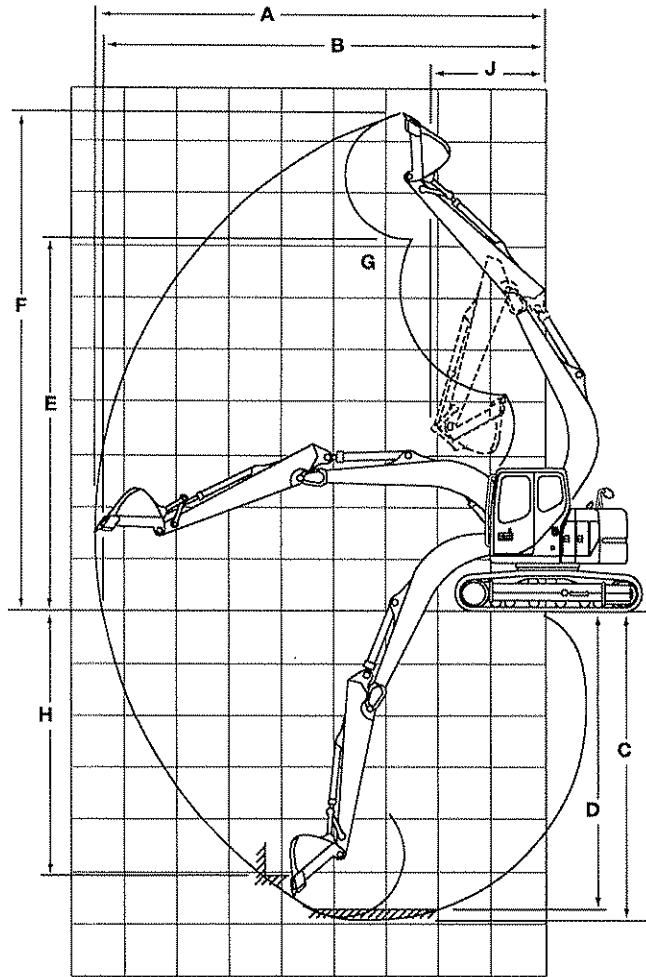

PERFORMANCE SPECS

	9 ft 4 in (2.85 m) Arm	7 ft 10 in (2.39 m) Arm
A. Maximum dig radius	28 ft 1 in (8.57 m)	26 ft 11 in (8.21 m)
B. Dig radius at groundline	27 ft 8 in (8.43 m)	26 ft 6 in (8.07 m)
C. Maximum dig depth	19 ft 5 in (5.91 m)	17 ft 11 in (5.47 m)
D. Dig depth - 8 ft 0 in (2.44 m) level bottom	18 ft 9 in (5.72 m)	17 ft 3 in (5.25 m)
E. Dump height	23 ft 5 in (7.13 m)	22 ft 8 in (6.91 m)
F. Overall reach height	31 ft 3 in (9.52 m)	30 ft 6 in (9.31 m)
G. Bucket rotation	178°	178°
H. Vertical straight wall dig depth	16 ft 8 in (5.08 m)	15 ft 11 in (4.85 m)
J. Minimum swing radius	7 ft 4 in (2.23 m)	5 ft 10 in (1.78 m)
Arm digging force		
Standard	13,399 lb (59.6 kN)	14,365 lb (63.9 kN)
Bucket digging force		
Standard	20,165 lb (89.7 kN)	20,165 lb (89.7 kN)

STANDARD EQUIPMENT

OPERATOR'S COMPARTMENT

Cab with Isomount® system
 Adjustable deluxe seat with
 3 in (76 mm) seat belt
 Safety glass
 Air conditioning
 AM/FM Radio w/auto tuner
 Skylight
 Sliding front windows
 Windshield wiper w/washer

ENGINE

Isuzu AJ-4JJ1X turbocharged diesel
 Tier III certified
 Glow plug
 Selectable one touch accelerator/decelerator

ELECTRICAL

Batteries (2) 12V
 Horn, dual

HYDRAULICS

ISO pattern pilot controls
 Position mode selector: S, E
 Variable flow piston pumps
 Neutral pump destroke
 Auxiliary hydraulic valve
 Boom and arm anti-drift valves
 Ultra Clean filtration system

UNDERCARRIAGE

Shoes: 23.6 in (600 mm) 3-bar, 43 per side
 Track length: 11 ft 6 in (3.51 m)
 Track gauge: 6 ft 6 in (1.99 m)

TRACK DRIVE

2-speed hydrostatic travel
 Straight tracking travel priority
 Disc-type parking brakes

UPPERSTRUCTURE

Boom: 15 ft 6 in (4.73 m) one piece
 Hammer adaptable, no reinforcing required
 Swing brake

OTHER

Counterweight: 7,099 lb (3220 kg)
 Single key vandal lockup

OPTIONAL EQUIPMENT

UPPERSTRUCTURE

Arm: 9 ft 4 in (2.85 m)

UPPERCARRIAGE

Track Shoes: 28 in (700 mm)
 Rubber Link Track
 Dozer blade
 Width: 8 ft 2 in (2.49 m)
 Height: 1 ft 10 in (.57 m)

HYDRAULICS

Auxiliary hydraulics
 Single acting, one pump
 Double acting, single or dual pump
 (includes heavy-duty bucket linkage)
 Double acting general purpose
 for use with thumb kit
 Control pattern selector valve

OTHER

Load holding control devices
 Cylinder mounted
 Case/JRB Slide-Loc® Hydraulic
 Coupler

BUCKETS

Application	Width	SAE Heaped Capacity
General Purpose	24 in thru 42 in (0.6 m thru 1.067 m)	0.50 yd³ thru 0.98 yd³ (0.40 m³ thru 0.75 m³)
Heavy-duty	24 in thru 39 in (0.6 m thru 1.00 m)	0.50 yd³ thru 0.89 yd³ (0.38 m³ thru 0.68 m³)
Ditching	60 in thru 66 in (1.52 m thru 1.68 m)	0.86 yd³ thru 0.96 yd³ (0.57 m³ thru 0.67 m³)

This page intentionally left blank.

NOTE: All specifications are stated in accordance with SAE Standards or Recommended Practices, where applicable.

NOTE: All engines meet current EPA emissions requirements.

IMPORTANT: CNH America LLC reserves the right to change these specifications without notice and without incurring any obligation relating to such change. CNH America LLC does not warrant the safety or reliability of attachments from other manufacturers.

Case is a registered trademark of CNH America LLC. Any trademarks referred to herein, in association with goods and/or services of companies other than CNH America LLC, are the property of those respective companies.



www.casece.com

PURCHASED PROTECTION PLAN TERMS AND CONDITIONS

This document sets out the terms and conditions that exclusively govern the Purchased Protection Plan. You are encouraged to familiarize yourself with its contents.

1. Definitions:

(a) As used herein, "Plan" means the purchased protection plan, in respect of the Goods, sold by the Provider to the Customer in return for a payment that is non-refundable to the extent permitted by applicable law.

(b) As used herein, "Provider" means EPG Insurance, Inc.

(c) As used herein, "Customer" means the purchaser of the Plan, or an assignee thereof as expressly permitted hereunder.

2. The Plan is a contract between the Provider and the Customer under which the Provider agrees to protect certain specified whole goods purchased by the Customer (the "Goods") according to the terms and conditions set out herein. **THE SCOPE AND EFFECTIVENESS OF THE PLAN IS HEREBY LIMITED EXCLUSIVELY TO THE TERMS AND CONDITIONS EXPRESSED HEREIN, AND THE CUSTOMER IS BOUND BY THESE TERMS AND CONDITIONS.**

3. Protection under the Plan applies, exclusively, to specified new or used Goods sold and registered by authorized CNH dealerships in the United States and operated exclusively in the United States, Puerto Rico and Canada.

4. Protection under the Plan is limited to reimbursement of the cost of parts, and labor for repairs, approved by the Provider, and made by a service center authorized by the Provider, if a defect in material or workmanship is found in the Goods; provided, however, that such reimbursement, as to Goods classified as "used" at the time they are purchased by the Customer, shall not exceed, in the aggregate for all claims made under the Plan, fifty percent (50%) of the value of the Goods at the time they were purchased by the Customer. The Master Parts Schedule attached hereto, and incorporated herein by this reference, lists the only parts protected under the Plan.

5. Protection under the Plan is limited to repairs to the Goods in accordance with the terms and conditions set out herein in consequence of a request for reimbursement authorized by the Provider for failure, due to defects in parts listed on the Master Parts Schedule, that occurs (a) during the term of the Plan, (b) after the expiration of the term of any applicable manufacturer's base warranty period, or any applicable manufacturer's extended warranty, in respect of such Goods, and (c) in respect of defects in the Goods arising after such expiration.

6. If parts are needed to effect an authorized repair, the Provider may require that only parts authorized by the Provider or genuine CNH remanufactured parts be used; such parts shall be protected exclusively under any CNH Replacement Parts Warranty while it remains in effect, and only thereafter under the Plan.

7. The Customer shall be solely responsible for payment for travel by personnel of the authorized service center to the Goods to repair them, including, without limitation, payment for the time of such personnel, unless the Plan specifies otherwise.

8. Protection under the Plan applies to the exploratory dismantling of the Goods only (a) in the event of a defect within the scope of such protection, and (b) with the prior authorization of the Customer; provided, however, that the Customer shall be responsible for all charges for exploratory dismantling if, as a result of such dismantling, the Provider determines that there has not been a failure that falls within the scope of protection under the Plan.

9. The Provider neither offers nor provides to the Customer any warranty, expressed or implied, for any component, or other item, that is separately warranted by such part's manufacturer.

10. For new Goods, protection under the Plan starts on the later of (i) the date the Goods are first registered for their base warranty by the selling dealership, as specified in the Warranty and Limitation of Liability Agreement signed by the Customer at the time of purchase of the Goods, and (ii) the time of expiration of the term of any applicable manufacturer's base warranty period, or any applicable manufacturer's extended warranty, in respect of such Goods, and ends on the earlier of (a) the expiration date of the Plan, or (b) the date on which the Goods have been operated for the maximum number of hours permitted. For greater certainty, the term of protection under the Plan does not include the term of the base warranty for such Goods.

11. For used Goods, protection under the Plan starts on the effective date of the Plan and ends on the earlier of (a) the expiration date of the Plan, or (b) the date on which the Goods have been operated for the maximum number of hours permitted.

12. Any transportation, travel, or other expenses will not be credited toward any applicable deductible, unless the Plan specifies otherwise. For new agricultural equipment, one deductible will apply to all reported failures that occur within any thirty (30) consecutive calendar days. For new construction equipment, and all used equipment, one deductible will apply to each reported failure.

13. To be eligible to receive any payment under the Plan, the Customer must have:

(a) performed all required maintenance on the Goods, at the recommended intervals specified in the Good's manufacturer's operator's manual, and must first present to the Provider proof of such maintenance, satisfactory to the Provider,

(b) operated the Goods exclusively within their rated capacity as specified in the Good's manufacturer's operator's manual, and

(c) promptly reported to the Provider any problems with respect to the performance of Goods.

14. CNH AMERICA LLC, ITS AFFILIATES, SUBSIDIARIES AND AUTHORIZED DEALERSHIPS AND THE PROVIDER, IF A DIFFERENT ENTITY, ARE NOT RESPONSIBLE FOR INCIDENTAL OR CONSEQUENTIAL DAMAGES. INCIDENTAL OR CONSEQUENTIAL DAMAGES INCLUDE, BUT ARE NOT LIMITED TO, LOST CROPS, LOST CONTRACTS, LOST INCOME, FINES, THEFT, FIRE, VANDALISM OR COLLISIONS. CNH AMERICA LLC, ITS AFFILIATES, SUBSIDIARIES AND AUTHORIZED DEALERSHIPS AND THE PROVIDER, IF A

DIFFERENT ENTITY, SPECIFICALLY HEREBY EXCLUDE THE IMPLIED WARRANTIES OF MERCHANTABILITY AND FITNESS FOR A PARTICULAR PURPOSE.

15. Protection under the Plan, in respect of Goods classified as "new" at the time the Customer purchased them, may be transferred to a new purchaser (a "New Purchaser") by a Customer at any time during the effective term of the Plan, upon the Provider accepting, from the New Purchaser, a Plan Registration Transfer Form satisfactory to the Provider. To transfer such protection under the Plan from the Customer to the New Purchaser, the Provider must first have received any required application fee as well as such Plan Registration Transfer Form. Such form must include, without limitation, the correct serial number(s) of the relevant Goods. Protection under the Plan in respect of Goods classified as "used" at the time they were purchased by the Customer may not be transferred.

16. If Goods, new when purchased by the Customer and protected under the Plan, are stolen or destroyed within their applicable base warranty period, due to no act, omission, or negligence on the part of the Customer, the Customer may, within six (6) months after such event of theft or destruction, transfer protection under the Plan to goods that are purchased from an authorized CNH dealership at a price acceptable to the Provider in its sole discretion.

17. No person, dealer or agent may in any way alter or extend the terms and conditions expressed herein without the prior written authorization of the Provider. Any accommodation made to the Customer by any party shall not constitute a waiver, modification or extension of the terms and conditions of the Plan as expressed herein.

18. A Customer may upgrade the scope of the Plan applicable to such Customer's Goods, by selecting a different Plan option at any time during the manufacturer's base warranty period applicable to such Goods, upon written request to the Provider and payment to the Provider of any additional cost of such different Plan option.

19. The Plan, and all protection thereunder, shall be void if:

(a) the Goods protected thereby are modified or altered, except with the prior written consent of the Provider or at the direction of the manufacturer of the Goods,

(b) the Goods' hour meter is changed or altered, other than by an authorized CNH dealership at the direction of the manufacturer of the Goods,

(c) the Goods' fuel or hydraulic system is changed or altered, without the prior written consent of the Provider,

(d) the Goods are used in any application for which they were not designed to be used,

(e) the Goods are scrapped, salvaged, stolen, junked, or totaled, or

(f) misrepresentation has occurred on the Purchased Protection Plan Registration as to the application(s) for which the Goods will be used.

20. Any dispute between the Customer and the Provider in respect of a payment due the Customer under the Plan shall be referred exclusively to an arbitrator to be appointed in accordance with the commercial rules of the American Arbitration Association.

PPP U.S. December 2007-RCF-20071114 Page 3

This literature is descriptive only. The precise protection afforded is subject to the terms, conditions and exclusions of the contract as issued. Program participation is subject to customer credit qualification. Programs may be changed or cancelled without notice. Capitalized terms used in this literature, unless defined herein, have the meanings assigned to them in the contract as issued.

21. The Plan gives the Customer specific legal rights and the Customer may also have other rights, which may vary, from state to state.

22. The following limitations and exclusions may not be allowed by some states and shall not apply to the extent not allowed by applicable state law:

(a) The Plan shall not protect Goods with respect to failure due to operating conditions, accidents, abuse, misuse, neglect, damage, weathering, or failure to follow the recommended adjustments or maintenance as described in the applicable manufacturer's operator's manual. Failure resulting from these factors is not eligible for reimbursement under the Plan.

(b) The Provider is not responsible for failure resulting from improper repair, or use of parts that are not authorized by the Provider or genuine CNH remanufactured parts.

(c) Reimbursement under the Plan shall not extend to the replacement of wear items normally replaced during the term of the Plan period, including, but not limited to, lights, flasher switches, ignition points, fuses and belts, brake or clutch linings, knives, bucket cutting edges and teeth, steel or rubber tracks and track components, crawler track pads and track components, crop processing and cutting components, external drive sprockets and chains, soil engaging tools, universal joints, resistors, disk bands, roller bearings and seals on undercarriage, quick couplers and grease fittings, lug nuts and studs, lubricated joints, pins and bushings, shovels and sweeps, and accessories or items replaced solely at the Customer's preference.

(d) Reimbursement under the Plan shall not extend to:

(i) normal maintenance parts and service, including, but not limited to, replenishment of oils, lubricants, spark plugs, coolants, thermostats, filters, and fuel injectors; provided, however, that lubricants, filters, and coolants may qualify for Plan reimbursement if they require replacement as a direct result of a defect in material or workmanship;

(ii) costs for coolant, fuel, or lube oil analysis, or supplies and lab recommendations relating thereto;

(iii) the repair of damage, including, but not limited to, damage resulting from air or water leaks caused by aged weather stripping, to Customer comfort items, including, but not limited to, carpets and floor mats, mirrors, glass, hinges, interior cab moldings and panels, knobs for switches, handles, and seat cushions;

(iv) repairs related exclusively to noise, such as rattles and squeaks;

(v) Goods covered by warranties or extended warranties, including, but not limited to, tires, batteries, fuel injection, transmissions, engines and advanced farming systems;

(vi) travel costs associated with transporting Goods to and from the location of repair without the prior written authorization of the Provider, unless the Plan specifies otherwise;

(vii) failure arising from the use of attachments not authorized in advance in writing by the Provider;

(viii) failure arising from the storage or deterioration of, or failure to properly maintain, the Goods, or negligence, improper use of the Goods, collision, accident, vandalism, fire, or other peril or casualty, or operation of the Goods beyond their rated capacity or specifications;

(ix) charges for labor performed other than by a service center authorized in advance in writing by the Provider;

(x) failure arising from abuse or neglect, including, but not limited to, operation without adequate coolant or lubricants, adjustments to the fuel system outside the Goods' manufacturer's specifications, illegal or improper speeding, or from improper storage, starting, warm-up, or shutdown practices, or use of incorrect or contaminated fuel, oil or other fluids; or failure arising from non-compliance with instructions provided by the manufacturer to prevent such failure;

(xi) failure of the Goods, their implements or attachments caused by improper field application, or overloading, beyond the manufacturer's specifications;

(xii) costs charged for overtime labor costs or out-of-shop expenses;

(xiii) economic loss, including, but not limited to, lost profits, crop loss, or cost of equipment rental;

(xiv) the cost of cleaning of Goods, in preparation for servicing;

(xv) loss or damage of the Goods during shipment;

(xvi) claims involving Goods damaged in transit or handling and subsequently sold as "salvage" Goods;

(xvii) the cost of initial setup or installation of any optional equipment or attachments to the Goods;

(xviii) items used for repairs, including, but not limited to, solvents, cleaners, anti-seize lubricants, oil-dry, special tools, shop towels, or other shop supplies;

(xix) the cost of normal maintenance services, including, but not limited to, checks, adjustments, and shimming, engine tune-ups, replacement of fuses, and engine fuel system cleaning, such as replacing fuel filters, cleaning, setting, or replacement of components due to fuel contamination, normal wear and/or low pressure, and repair of corrosion, decay and deterioration to items such as radiators and coolers;

(xx) repairs subsequent to, or in connection with, unauthorized modification of, or "field fixes" to, the Goods;

(xxi) claims in respect of a complete assembly, if the combined cost of parts and labor to repair the assembly are less than the replacement cost of the entire assembly, other than with the prior written authorization of the Provider or at the direction of the manufacturer of the Goods;

(xxii) claims in respect of the inspection or reconditioning of the Goods;

(xxiii) any duplicate, repeat, or comeback repair resulting from improper diagnosis, testing, or poor service work within sixty (60) days after a protected failure;

(xxiv) the cost of removing optional equipment or attachments that were installed without the prior written permission of the Provider, including, but not limited to, loaders, duals, and tanks;

(xxv) Goods sold "as is", other than with the written authorization of the Provider at the time of sale;

(xxvi) lost or stolen equipment;

(xxvii) costs related to the failure of a part replaced pursuant to an OEM parts warranty;

(xxviii) original equipment repair of Goods covered by a warranty issued to the retail purchaser; or repair covered by the manufacturer under a field campaign or recall policy;

(xxix) diagnosis, except according to published CNH labor time schedules in respect of hydraulic pump testing;

(xxx) parts or repairs covered by a warranty supplied by the parts manufacturer;

(xxxi) repairs to CNH remanufactured fuel injection pumps (as such pumps must be replaced);

(xxxii) ensuing loss arising from a failure, including, without limitation, such loss caused by fire;

(xxxiii) severe usage, unless the Plan provides otherwise;

(xxxiv) severe duty applications, including, without limitation, the use of Goods in demolition, foundry, scrap, waste recycling, landfill, mining, tree mowing, or forestry work or in the warehousing of chemicals, unless the Plan specifies otherwise.

(e) Reimbursement under the Plan shall not extend to failure due to tampering with, adjustments or additions of components to, or replacements for Goods, when such actions could contribute to increasing the published horsepower rating of any engine-powered Goods.

(f) Any part installed on the Goods, if such part is under a manufacturer's whole goods warranty or service parts warranty, shall be deemed to be under whichever of such warranties that terminates last.

23. THE REMEDIES OF HAVING A DEFECT IN MATERIAL OR WORKMANSHIP REPAIRED, OR HAVING DEFECTIVE MATERIALS REPLACED, AT A SERVICE CENTER AUTHORIZED BY THE PROVIDER UNDER THE TERMS AND CONDITIONS OF THE PLAN ARE THE CUSTOMER'S EXCLUSIVE REMEDIES UNDER THE PLAN AND ARE IN LIEU OF ANY OTHER REMEDY OR REMEDIES OTHERWISE AVAILABLE.

PPP U.S. December 2007-RCF-20071114 Page 6

This literature is descriptive only. The precise protection afforded is subject to the terms, conditions and exclusions of the contract as issued. Program participation is subject to customer credit qualification. Programs may be changed or cancelled without notice. Capitalized terms used in this literature, unless defined herein, have the meanings assigned to them in the contract as issued.

24. Only the Provider has any liability in respect of claims made under the Plan.

25. The Plan does not provide protection in respect of any agricultural tractor used in a scraper, earthmoving or non-agricultural application for which the Customer receives compensation unless such tractor is designated by its manufacturer as suitable for such application. A Customer using a scraper on his or her own farm to level land for agricultural crop preparation may use an agricultural tractor in such application for not more than (50%) of such tractor's total annual hours of operation; exceeding this limit in any period of twelve (12) consecutive months will make such tractor ineligible for further protection under the Plan. Use of an agricultural tractor in any of the following commercial applications will make such tractor ineligible for further protection under the Plan: site preparation, excavation, pond-building and forestry applications.

26. The terms and conditions set out herein supercede and replace any and all agreements, representations, understandings, and terms and conditions whatsoever made by any party whatsoever prior to the issuance hereof to the Customer and contain the entire understanding of the Customer, and all other parties named herein, with respect to the subject matter hereof. The unenforceability of any term or condition set out herein shall not be construed to limit the enforceability of any other term or condition set out herein. The waiver or non-enforcement by a party named herein, other than the Customer, of a right, requirement, term or condition set out herein shall not operate in law or in equity to prevent such party from later enforcing such or similar rights, requirements, terms or conditions. No changes may be made to the Plan unless approved by the Provider in writing.

27. The Plan shall be interpreted for all purposes in accordance with the laws of the state of Wisconsin.

28. The Plan does not guarantee days or time of service. The Provider is not liable for any damages whatsoever arising out of delays, either before or after a day or time of service is agreed upon.

29. If the Provider pays for repairs under this Plan and the Customer is also repaid for the same repairs by someone else, the Customer's payment will become the Provider's property up to the amount that the Provider paid for the repairs.

Master Parts Schedule- New Construction Equipment (see exclusions in PPP Policy Document)

Powertrain Only	Powertrain Plus Electronics	Powertrain Plus Hydraulics	Full Machine
<p>The Powertrain Only coverage provides for the following engine and driveline Components. Any Component not listed below is not covered under the Powertrain Only Coverage.</p> <p><u>Engine</u> All internal, lubricated parts that are captured between the valve cover and oil pan, cylinder block and head, front cover and flywheel housing, turbocharger and water pump.</p> <p><u>Drive Line</u> Drive (flex) plates/flywheel Drive axle assembly Drive couplings Drive shafts Final drive/planetary Hydraulic Drive Motor (on Hydrostatically Driven units only, including Excavators) Hydraulic Drive Pump(on Hydrostatically driven units Only, including Excavators) Hydraulic Pump (when used as a Swing Reducer) Transmission Torque converter Track Steering Brakes Transfer Gear Group Transmission Charge Pump Transmission/Transmission Control Valve Turntable Bearing/ Swing Gear/ Hydraulic Swivel Electronic Engine Controls Injection Pumps Wet Brakes/Wet clutch MFWD Assemblies</p>	<p>Powertrain Plus Electronics includes Powertrain Only Components along with the following Major Components systems:</p> <p><u>Drive Train Electronic Controls</u> Traction Control System Electronic Control Module Wheel Speed Sensor Brake Proportional Solenoid Valve On / Off Pilot Solenoid Valve Articulation Angle Position Sensor Brake Pressure Reducing Valve Drive Train Electronic Control Module Brake Position Sensor</p> <p><u>Implement Electronic Controls</u> Implement Electronic Control Module Frame Level Control Linkage Position Sensor Control Lever Position Sensor</p> <p><u>Exclusions:</u> Wiring Harnesses, Instruments Gauges Resistors Indicators Light Bulbs Circuit Breakers Fuses Switches Motors Electric Joysticks Batteries</p>	<p>Powertrain Plus Hydraulics includes the Powertrain Only components along with the following Major Component systems:</p> <p><u>Hydraulics</u> Main Hydraulic Pump Steering pump Main control valves Hydraulic lift cylinders Hydraulic lift/dump cylinders Hydraulic steering cylinders Hydraulic boom cylinders Hydraulic stick cylinders Hydraulic bucket cylinders</p> <p>Hoses, excluding external packing, seals, o-rings and bonded washers, quick connects.</p> <p>O-ring failures in hoses, not related to loose fittings or worn out seals, are covered.</p>	<p>Full Machine includes the Powertrain Only, Powertrain Plus Electronics, and Powertrain Plus Hydraulics, along with the following Major Component systems:</p> <p><u>Fuel system</u> Fuel Transfer/ lift pumps, Injection pumps and lines that do not fall into the Emissions Warranty guidelines.</p> <p><u>Electrical</u> Wiring harnesses Sensors Instruments Gauges Indicators Circuit Breakers Relays Switches Motors Joysticks</p> <p><u>Hydraulics</u> Steering Hydraulic Components</p> <p><u>Chassis/ Frame/Cab</u> Weldment failures A/C system (excludes Dryer Failures) Exhaust system: includes manifolds and muffler Internal door latch mechanisms/ Weldment failures Cooling System: Radiator and cooler failures not related to corrosion, decay, or deterioration</p> <p><u>Exclusions:</u> Comfort Items listed in policy document</p>
<p>*Note: Emissions and Parts Warranty related failures should be filed back to the manufacturer, and NOT through PPP; in accordance with the manufacturer's operating guidelines and conditions</p>			
<p>**Note: Field Campaigns/factory directed repairs should NOT be filed through the PPP. Please direct to the Manufacturer.</p>			

Revised 7.24.2007

This literature is descriptive only. The precise protection afforded is subject to the terms, conditions and exclusions of the contract as issued. Program participation is subject to customer credit qualification. Programs may be changed or cancelled without notice. Capitalized terms used in this literature, unless defined herein, have the meanings assigned to them in the contract as issued.

MASTER PARTS SCHEDULE – USED CONSTRUCTION EQUIPMENT

POWERTRAIN

ENGINE

Engine Block
Cylinder Liners
Front & Rear Engine Covers
Crankshaft
Crankshaft Bearings & Gear
Front & Rear Crankshaft Seals
Flywheel, Ring Gear
Cylinder Heads
Rocker Arm Assembly
Valves (Intake / Exhaust)
Valve Cover
Camshaft
Camshaft Bearings
Camshaft Drive Gear
Timing Gears
Accessory Gears
Pistons & Rings
Connecting Rods & Bearings
Turbocharger
Oil Pump
Oil Pan

TRANSMISSION

Transmission Case
Counter Shaft Clutch
Transmission Pump
Torque Converter Pump
Transmission Gears, Bearings, & Shafts
Torque Converter
Splitter Drive
Transfer Drive
Hydraulic Transmission-
Control Valves
Hydrostatic Transmission Charge
Pump Hydrostatic Transmission
Variable-
Displacement Pump
Hydrostatic Transmission Rotary
Group.
Internal Transmission Control
Linkage

DRIVE LINE

Axle Shaft

AIR COMPRESSOR

Air end (excludes separator)

DIFFERENTIAL / FINAL DRIVE

Differential Housing
Differential Pinion Gear / Ring
Gear
Drive Axle Hub
Final Drive Planetary Gears
Final Drive Pinion
Planetary Gear Carrier

DIFFERENTIAL / FINAL DRIVE (HYDROSTATIC EQUIPMENT)

Hydraulic Drive Pump
Hydraulic Drive / Travel Motor
Swing Motor and Swing Gear Box
Control Valve (Travel and Swing
functions only. Travel & Swing
sections of valve, Excludes Dig
Functions)

COMPACTION/PAVING EQUIPMENT

Propulsion System Hydraulic
Components
Torque Hubs
Pump Drive
Splitter Box
Reduction Unit
Vibration System Hydraulic
Components
Eccentric Mechanism & bearings

POWERTRAIN PLUS HYDRAULICS

Pumps

Valves

Hydraulic cylinders

Exclusions: packing, seals, o-rings, bonded washers, hoses, couplers, filters, quick connect, pipes, breathers and oil

The following wear item parts are NOT covered:

Water Pump

Clutch Plates (wet only)

Fuel Lift Pump

Clutch Discs (wet only)

Injection Pump

Wet steering clutches

Damper

Drive Shaft Support Bearing

Universal Joints

Mud Pump