

*Golden Equipment Co., Inc.*

Main Office ♦ PO Box 873 ♦ Mars, Pennsylvania 16046  
(800) 242-1494 ♦ (724) 625-3100 ♦ Fax (724)625-3744

Public Works

Sewer

Contractors Equipment

---

---

West Virginia Department of Transportation  
Attn: Purchasing Division

October 22, 2008

Dear WV. D.O.T.

Thank you for the opportunity to bid on your trailer mounted Hot Patcher Units. We have bid with one minor exception to your published specification. That deviation is the rearward slope angle, specifications call for a 60 degree, and we are offering a 45 degree slope. In no way does this minor exception affect the performance of the Spaulding unit. We have enclosed a diagram showing the different slopes.

Spaulding MFG. has an excellent reputation in manufacturing quality products and Golden Equipment Co., Inc has the same reputation in providing service and parts in a timely manner.

If you have any questions or require additional information, please contact us at your convenience. We look forward to serving your equipment needs.

Sincerely,

Mark A. Golden  
President



State of West Virginia  
 Department of Administration  
 Purchasing Division  
 2019 Washington Street East  
 Post Office Box 50130  
 Charleston, WV 25305-0130

# Request for Quotation

RFQ NUMBER  
**709EC005**

PAGE  
**1**

ADDRESS CORRESPONDENCE TO ATTENTION OF  
**MICHAEL AUSTIN  
 304-558-2402**

RFQ COPY  
 TYPE NAME/ADDRESS HERE



Golden Equipment Co., Inc.  
 P.O. Box 873  
 Mars, PA 16046-0873

SHIP TO

DIVISION OF HIGHWAYS  
 EQUIPMENT DIVISION  
 ROUTE 33  
 BRUSHY FORK ROAD  
 BUCKHANNON, WV  
 26201 304-472-1750

DATE PRINTED	TERMS OF SALE	SHIP VIA	F.O.B.	FREIGHT TERMS
09/23/2008				
BID OPENING DATE: 10/22/2008		BID OPENING TIME 01:30PM		

LINE	QUANTITY	UOP	CAT NO	ITEM NUMBER	UNIT PRICE	AMOUNT
0001	1	EA		070-61	22,530.00	22,530.00
	2 CUBIC YARD	3 TON TRAILER MOUNTED HOT PATCH UNIT				
		OPEN END CONTRACT				
		TO PROVIDE 2 CUBIC YARD 3 TON TRAILER MOUNTED HOT PATCH UNIT FOR THE WEST VIRGINIA DIVISION OF HIGHWAYS PER THE ATTACHED SPECIFICATIONS.				
		THERE WILL BE A MANDATORY PRE-BID CONFERENCE AT THE EQUIPMENT DIVISION BUCKHANNON, WV AT 1:00 PM ON 10/09/2008. FAILURE TO ATTEND THE PRE-BID WILL RESULT IN BID DISQUALIFICATION.				
		QUESTIONS: WRITTEN QUESTIONS MUST BE RECEIVED BY CLOSE OF BUSINESS (5:00 PM EST.) ON FRIDAY, 10/03/08. SEND YOUR QUESTIONS TO: PURCHASING DIVISION ATTENTION MICHAEL AUSTIN 2019 WASHINGTON STREET EAST CHARLESTON, WV 25305				
		QUESTIONS MAY BE SENT VIA FAX, E-MAIL OR REGULAR MAIL. E-MAIL: MICHAEL.D.AUSTIN@WV.GOV FAX: 304-558-4115				
		IT IS THE VENDORS RESPONSIBILITY TO VERIFY THAT THEIR QUESTIONS HAVE BEEN RECEIVED BY CALLING 304-558-2402.				
		EXHIBIT 2				
		LIFE OF CONTRACT: THIS CONTRACT BECOMES EFFECTIVE ON ..... AND EXTENDS FOR A PERIOD OF ONE (1)				

RECEIVED  
 OCT 21 2008  
 DIVISION OF HIGHWAYS

SEE REVERSE SIDE FOR TERMS AND CONDITIONS			
SIGNATURE <i>[Signature]</i>	TELEPHONE 1-800-242-1494	DATE 10-22-08	
TITLE PRESIDENT	FEIN 25-153-7261	ADDRESS CHANGES TO BE NOTED ABOVE	

WHEN RESPONDING TO RFQ, INSERT NAME AND ADDRESS IN SPACE ABOVE LABELED 'VENDOR'

**GENERAL TERMS & CONDITIONS**  
**REQUEST FOR QUOTATION (RFQ) AND REQUEST FOR PROPOSAL (RFP)**

1. Awards will be made in the best interest of the State of West Virginia
2. The State may accept or reject in part, or in whole, any bid.
3. All quotations are governed by the *West Virginia Code* and the *Legislative Rules* of the Purchasing Division
4. Prior to any award, the apparent successful vendor must be properly registered with the Purchasing Division and have paid the required \$125 fee.
5. All services performed or goods delivered under State Purchase Order/Contracts are to be continued for the term of the Purchase Order/Contracts, contingent upon funds being appropriated by the Legislature or otherwise being made available. In the event funds are not appropriated or otherwise available for these services or goods, this Purchase Order/Contract becomes void and of no effect after June 30.
6. Payment may only be made after the delivery and acceptance of goods or services
7. Interest may be paid for late payment in accordance with the *West Virginia Code*
8. Vendor preference will be granted upon written request in accordance with the *West Virginia Code*
9. The State of West Virginia is exempt from federal and state taxes and will not pay or reimburse such taxes.
10. The Director of Purchasing may cancel any Purchase Order/Contract upon 30 days written notice to the seller
11. The laws of the State of West Virginia and the *Legislative Rules* of the Purchasing Division shall govern all rights and duties under the Contract, including without limitation the validity of this Purchase Order/Contract.
12. Any reference to automatic renewal is hereby deleted. The Contract may be renewed only upon mutual written agreement of the parties.
13. **BANKRUPTCY:** In the event the vendor/contractor files for bankruptcy protection, this Contract may be deemed null and void, and terminated without further order.
14. **HIPAA BUSINESS ASSOCIATE ADDENDUM:** The West Virginia State Government HIPAA Business Associate Addendum (BAA), approved by the Attorney General, and available online at the Purchasing Division's web site (<http://www.state.wv.us/admin/purchase/vrc/hipaa.htm>) is hereby made part of the agreement. Provided that, the Agency meets the definition of a Cover Entity (45 CFR §160.103) and will be disclosing Protected Health Information (45 CFR §160.103) to the vendor
15. **WEST VIRGINIA ALCOHOL & DRUG-FREE WORKPLACE ACT:** If this Contract constitutes a public improvement construction contract as set forth in Article 1D, Chapter 21 of the West Virginia Code ("The West Virginia Alcohol and Drug-Free Workplace Act"), then the following language shall hereby become part of this Contract: "The contractor and its subcontractors shall implement and maintain a written drug-free workplace policy in compliance with the West Virginia Alcohol and Drug-Free Workplace Act, as set forth in Article 1D, Chapter 21 of the West Virginia Code. The contractor and its subcontractors shall provide a sworn statement in writing, under the penalties of perjury, that they maintain a valid drug-free work place policy in compliance with the West Virginia and Drug-Free Workplace Act. It is understood and agreed that this Contract shall be cancelled by the awarding authority if the Contractor: 1) Fails to implement its drug-free workplace policy; 2) Fails to provide information regarding implementation of the contractor's drug-free workplace policy at the request of the public authority; or 3) Provides to the public authority false information regarding the contractor's drug-free workplace policy."

---

**INSTRUCTIONS TO BIDDERS**

1. Use the quotation forms provided by the Purchasing Division.
2. **SPECIFICATIONS:** Items offered must be in compliance with the specifications. Any deviation from the specifications must be clearly indicated by the bidder. Alternates offered by the bidder as **EQUAL** to the specifications must be clearly defined. A bidder offering an alternate should attach complete specifications and literature to the bid. The Purchasing Division may waive minor deviations to specifications.
3. Complete all sections of the quotation form
4. Unit prices shall prevail in case of discrepancy.
5. All quotations are considered F.O.B destination unless alternate shipping terms are clearly identified in the quotation.
6. **BID SUBMISSION:** All quotations must be delivered by the bidder to the office listed below prior to the date and time of the bid opening. Failure of the bidder to deliver the quotations on time will result in bid disqualifications: Department of Administration, Purchasing Division, 2019 Washington Street East, P.O. Box 50130, Charleston, WV 25305-0130



State of West Virginia  
 Department of Administration  
 Purchasing Division  
 2019 Washington Street East  
 Post Office Box 50130  
 Charleston, WV 25305-0130

# Request for Quotation

RFQ NUMBER
709EC005

PAGE
2

ADDRESS CORRESPONDENCE TO ATTENTION OF
MICHAEL AUSTIN 304-558-2402

RFQ COPY  
 TYPE NAME/ADDRESS HERE



Golden Equipment Co., Inc.  
 P.O. Box 873  
 Mars, PA 16046-0873

DIVISION OF HIGHWAYS  
 EQUIPMENT DIVISION  
 ROUTE 33  
 BRUSHY FORK ROAD  
 BUCKHANNON, WV  
 26201 304-472-1750

DATE PRINTED	TERMS OF SALE	SHIP VIA	F.O.B.	FREIGHT TERMS
09/23/2008				

BID OPENING DATE: 10/22/2008 BID OPENING TIME 01:30PM

LINE	QUANTITY	LOP	CAT NO	ITEM NUMBER	UNIT PRICE	AMOUNT
<p>YEAR OR UNTIL SUCH "REASONABLE TIME" THEREAFTER AS IS NECESSARY TO OBTAIN A NEW CONTRACT OR RENEW THE ORIGINAL CONTRACT. THE "REASONABLE TIME" PERIOD SHALL NOT EXCEED TWELVE (12) MONTHS. DURING THIS "REASONABLE TIME" THE VENDOR MAY TERMINATE THIS CONTRACT FOR ANY REASON UPON GIVING THE DIRECTOR OF PURCHASING THIRTY (30) DAYS WRITTEN NOTICE.</p> <p>UNLESS SPECIFIC PROVISIONS ARE STIPULATED IN THIS CONTRACT DOCUMENT, THE TERMS, CONDITIONS, AND PRICING SET HEREIN ARE FIRM FOR THE LIFE OF THE CONTRACT.</p> <p>RENEWAL: THIS CONTRACT MAY BE RENEWED UPON THE MUTUAL WRITTEN CONSENT OF THE SPENDING UNIT AND VENDOR, SUBMITTED TO THE DIRECTOR OF PURCHASING THIRTY (30) DAYS PRIOR TO THE EXPIRATION DATE. SUCH RENEWAL SHALL BE IN ACCORDANCE WITH THE TERMS AND CONDITIONS OF THE ORIGINAL CONTRACT AND SHALL BE LIMITED TO TWO (2) ONE (1) YEAR PERIODS.</p> <p>CANCELLATION: THE DIRECTOR OF PURCHASING RESERVES THE RIGHT TO CANCEL THIS CONTRACT IMMEDIATELY UPON WRITTEN NOTICE TO THE VENDOR IF THE COMMODITIES AND/OR SERVICES SUPPLIED ARE OF AN INFERIOR QUALITY OR DO NOT CONFORM WITH THE SPECIFICATIONS OF THE BID AND CONTRACT HEREIN.</p> <p>OPEN MARKET CLAUSE: THE DIRECTOR OF PURCHASING MAY AUTHORIZE A SPENDING UNIT TO PURCHASE ON THE OPEN MARKET, WITHOUT THE FILING OF A REQUISITION OR COST ESTIMATE, ITEMS SPECIFIED ON THIS CONTRACT FOR IMMEDIATE DELIVERY IN EMERGENCIES DUE TO UNFORESEEN CAUSES (INCLUDING BUT NOT LIMITED TO DELAYS IN TRANSPORTATION OR AN UNANTICIPATED INCREASE IN THE VOLUME OF WORK).</p> <p>QUANTITIES: QUANTITIES LISTED IN THE REQUISITION ARE APPROXIMATIONS ONLY, BASED ON ESTIMATES SUPPLIES BY TH</p>						

SEE REVERSE SIDE FOR TERMS AND CONDITIONS

SIGNATURE	TELEPHONE	DATE
TITLE	FEIN	ADDRESS CHANGES TO BE NOTED ABOVE

WHEN RESPONDING TO RFQ, INSERT NAME AND ADDRESS IN SPACE ABOVE LABELED 'VENDOR'



State of West Virginia  
 Department of Administration  
 Purchasing Division  
 2019 Washington Street East  
 Post Office Box 50130  
 Charleston, WV 25305-0130

# Request for Quotation

RFQ NUMBER  
**709EC005**

PAGE  
**3**

ADDRESS CORRESPONDENCE TO ATTENTION OF  
**MICHAEL AUSTIN**  
**304-558-2402**

**RFQ COPY**  
 TYPE NAME/ADDRESS HERE

VENDOR



Golden Equipment Co., Inc.  
 P.O. Box 873  
 Mars, PA 16046-0873

SHIP TO

**DIVISION OF HIGHWAYS**  
**EQUIPMENT DIVISION**  
**ROUTE 33**  
**BRUSHY FORK ROAD**  
**BUCKHANNON, WV**  
**26201**      **304-472-1750**

DATE PRINTED	TERMS OF SALE	SHIP VIA	F.O.B.	FREIGHT TERMS
<b>09/23/2008</b>				

BID OPENING DATE: **10/22/2008**      BID OPENING TIME **01:30PM**

LINE	QUANTITY	UOP	CAT NO	ITEM NUMBER	UNIT PRICE	AMOUNT
<p>STATE SPENDING UNIT. IT IS UNDERSTOOD AND AGREED THAT THE CONTRACT SHALL COVER THE QUANTITIES ACTUALLY ORDERED FOR DELIVERY DURING THE TERM OF CONTRACT, WHETHER MORE OR LESS THAN THE QUANTITIES SHOWN.</p> <p>ORDERING PROCEDURE: SPENDING UNIT(S) SHALL ISSUE A WRITTEN EQUIPMENT CONTRACT ORDER (FORM NUMBER WV-35) FOR COMMODITIES COVERED BY THIS CONTRACT. THE ORIGINAL WV-35 MUST BE SENT TO THE PURCHASING DIVISION OF THE DEPARTMENT OF ADMINISTRATION. AFTER APPROVAL AND ENCUMBRANCE, ONE COPY OF THE PURCHASE ORDER WILL BE RETURNED TO THE SPENDING UNIT AND ONE COPY FORWARDED TO THE VENDOR AS AUTHORIZATION FOR SHIPMENT. NO ORDER IS VALID UNLESS APPROVED AND ENCUMBERED BY THE PURCHASING DIVISION.</p> <p>BANKRUPTCY: IN THE EVENT THE VENDOR/CONTRACTOR FILES FOR BANKRUPTCY PROTECTION, THIS CONTRACT IS AUTOMATICALLY NULL AND VOID, AND IS TERMINATED WITHOUT FURTHER ORDER.</p> <p>REV. 9/98</p> <p>EXHIBIT 4</p> <p>LOCAL GOVERNMENT BODIES: UNLESS THE VENDOR INDICATES IN THE BID HIS REFUSAL TO EXTEND THE PRICES, TERMS, AND CONDITIONS OF THE BID TO COUNTY, SCHOOL, MUNICIPAL AND OTHER LOCAL GOVERNMENT BODIES, THE BID SHALL EXTEND TO POLITICAL SUBDIVISIONS OF THE STATE OF WEST VIRGINIA. IF THE VENDOR DOES NOT WISH TO EXTEND THE PRICES, TERMS, AND CONDITIONS OF THE BID TO ALL POLITICAL SUBDIVISIONS OF THE STATE, THE VENDOR MUST CLEARLY INDICATE SUCH REFUSAL IN HIS BID. SUCH REFUSAL SHALL NOT PREJUDICE THE AWARD OF THIS CONTRACT IN ANY</p>						

SEE REVERSE SIDE FOR TERMS AND CONDITIONS

SIGNATURE	TELEPHONE	DATE
TITLE	FEIN	ADDRESS CHANGES TO BE NOTED ABOVE

WHEN RESPONDING TO RFQ, INSERT NAME AND ADDRESS IN SPACE ABOVE LABELED 'VENDOR'



State of West Virginia  
 Department of Administration  
 Purchasing Division  
 2019 Washington Street East  
 Post Office Box 50130  
 Charleston, WV 25305-0130

# Request for Quotation

RFQ NUMBER  
**709EC005**

PAGE  
**4**

ADDRESS CORRESPONDENCE TO ATTENTION OF  
**MICHAEL AUSTIN  
 304-558-2402**

RFQ COPY  
 TYPE NAME/ADDRESS HERE



Golden Equipment Co., Inc.  
 P.O. Box 873  
 Mars, PA 16046-0873

DIVISION OF HIGHWAYS  
 EQUIPMENT DIVISION  
 ROUTE 33  
 BRUSHY FORK ROAD  
 BUCKHANNON, WV  
 26201 304-472-1750

DATE PRINTED	TERMS OF SALE	SHIP VIA	F.O.B.	FREIGHT TERMS
09/23/2008				

BID OPENING DATE: **10/22/2008** BID OPENING TIME **01:30PM**

LINE	QUANTITY	UOP	CAT NO	ITEM NUMBER	UNIT PRICE	AMOUNT
	MANNER.					
	REV. 3/88					
	EXHIBIT 6					
	<p>PRICE ADJUSTMENT PROVISION:            THE STATE OF WEST VIRGINIA WILL CONSIDER BIDS THAT CONTAIN PROVISIONS FOR PRICE ADJUSTMENTS PRIOR TO THE ORIGINAL EXPIRATION OF THE CONTRACT, PROVIDED THAT SUCH PRICE ADJUSTMENT COVERS BOTH UPWARD AND DOWNWARD MOVEMENT OF THE COMMODITY PRICE, AND THAT ADJUSTMENT IS BASED ON THE "PASS THROUGH" INCREASE OR DECREASE OF RAW MATERIALS AND/OR LABOR, WHICH MAKE UP ALL OR A SUBSTANTIAL PART OF A PRODUCT. ADJUSTMENTS ARE TO BE BASED UPON AN ACTUAL DOLLAR FIGURE, NOT A PERCENTAGE. ALL PRICE ADJUSTMENT REQUESTS MUST BE SUBSTANTIATED IN A MANNER ACCEPTABLE TO THE DIRECTOR PURCHASING, E.G. GOVERNMENTAL BENCH MARKS, GENERAL MARKET INCREASE, PUBLISHED PRICE LISTS. SUCH REQUESTS FOR AND INCREASE SHOULD BE RECEIVED IN WRITING BY THE DIRECTOR OF PURCHASING AT LEAST 30 DAYS IN ADVANCE OF THE EFFECTIVE DATE OF THE INCREASE. ANY TIME THE VENDOR REQUESTS A PRICE ADJUSTMENT, THE PURCHASING DIVISION MAY EITHER ACCEPT THE PRICE ADJUSTMENT AND AMEND THE CONTRACT ACCORDINGLY OR REJECT THE ADJUSTMENT IN ITS ENTIRETY AND CANCEL THE CONTRACT.</p>					
	EXHIBIT 10					
	ADDENDUM ACKNOWLEDGEMENT					
				REQUISITION NO.: 709.EC.005...		

SEE REVERSE SIDE FOR TERMS AND CONDITIONS

SIGNATURE	TELEPHONE	DATE
TITLE	FERN	ADDRESS CHANGES TO BE NOTED ABOVE

WHEN RESPONDING TO RFQ, INSERT NAME AND ADDRESS IN SPACE ABOVE LABELED 'VENDOR'



State of West Virginia  
 Department of Administration  
 Purchasing Division  
 2019 Washington Street East  
 Post Office Box 50130  
 Charleston, WV 25305-0130

# Request for Quotation

RFQ NUMBER
709EC005

PAGE
5

ADDRESS CORRESPONDENCE TO ATTENTION OF
MICHAEL AUSTIN 304-558-2402

RFQ COPY  
 TYPE NAME/ADDRESS HERE

VENDOR



Golden Equipment Co., Inc.  
 P.O. Box 873  
 Mars, PA 16046-0873

SHIP TO

DIVISION OF HIGHWAYS  
 EQUIPMENT DIVISION  
 ROUTE 33  
 BRUSHY FORK ROAD  
 BUCKHANNON, WV  
 26201 304-472-1750

DATE PRINTED	TERMS OF SALE	SHIP VIA	FOR	FREIGHT TERMS
09/23/2008				

BID OPENING DATE: 10/22/2008 BID OPENING TIME 01:30PM

LINE	QUANTITY	UOP	CAT NO	ITEM NUMBER	UNIT PRICE	AMOUNT
<p>I HEREBY ACKNOWLEDGE RECEIPT OF THE FOLLOWING CHECKED ADDENDUM(S) AND HAVE MADE THE NECESSARY REVISIONS TO MY PROPOSAL, PLANS AND/OR SPECIFICATION, ETC.</p> <p>ADDENDUM NO.'S:</p> <p>NO. 1 .....</p> <p>NO. 2 .....</p> <p>NO. 3 .....</p> <p>NO. 4 .....</p> <p>NO. 5 .....</p> <p>I UNDERSTAND THAT FAILURE TO CONFIRM THE RECEIPT OF TH ADDENDUM(S) MAY BE CAUSE FOR REJECTION OF BIDS.</p> <p>VENDOR MUST CLEARLY UNDERSTAND THAT ANY VERBAL REPRESENTATION MADE OR ASSUMED TO BE MADE DURING ANY ORAL DISCUSSION HELD BETWEEN VENDOR'S REPRESENTATIVES AND ANY STATE PERSONNEL IS NOT BINDING. ONLY THE INFORMATION ISSUED IN WRITING AND ADDED TO THE SPECIFICATIONS BY AN OFFICIAL ADDENDUM IS BINDING.</p> <p>..... SIGNATURE</p> <p>.....Golden Equipment Co, Inc..... COMPANY</p> <p>.....10-22-08..... DATE</p>						

SEE REVERSE SIDE FOR TERMS AND CONDITIONS

SIGNATURE	TELEPHONE	DATE
TITLE	FEIN	ADDRESS CHANGES TO BE NOTED ABOVE

WHEN RESPONDING TO RFQ, INSERT NAME AND ADDRESS IN SPACE ABOVE LABELED 'VENDOR'



State of West Virginia  
 Department of Administration  
 Purchasing Division  
 2019 Washington Street East  
 Post Office Box 50130  
 Charleston, WV 25305-0130

# Request for Quotation

RFQ NUMBER  
**709EC005**

PAGE  
**6**

ADDRESS CORRESPONDENCE TO ATTENTION OF  
**MICHAEL AUSTIN  
 304-558-2402**

RFQ COPY  
 TYPE NAME/ADDRESS HERE



Golden Equipment Co., Inc.  
 P.O. Box 873  
 Mars, PA 16046-0873

DIVISION OF HIGHWAYS  
 EQUIPMENT DIVISION  
 ROUTE 33  
 BRUSHY FORK ROAD  
 BUCKHANNON, WV  
 26201 304-472-1750

DATE PRINTED	TERMS OF SALE	SHIP VIA	FOB	FREIGHT TERMS
09/23/2008				

BID OPENING DATE: **10/22/2008** BID OPENING TIME **01:30PM**

LINE	QUANTITY	UOF	CAT NO	ITEM NUMBER	UNIT PRICE	AMOUNT
<p>REV. 11/96</p> <p style="text-align: center;"><b>NOTICE</b></p> <p><b>A SIGNED BID MUST BE SUBMITTED TO:</b></p> <p style="text-align: center;">DEPARTMENT OF ADMINISTRATION            PURCHASING DIVISION            BUILDING 15            2019 WASHINGTON STREET, EAST            CHARLESTON, WV 25305-0130</p> <p><b>THE BID SHOULD CONTAIN THIS INFORMATION ON THE FACE OF THE ENVELOPE OR THE BID MAY NOT BE CONSIDERED:</b></p> <p><b>SEALED BID</b></p> <p><b>BUYER:</b> 33</p> <p><b>RFQ. NO.:</b> 709EC005</p> <p><b>BID OPENING DATE:</b> 10-22-08</p> <p><b>BID OPENING TIME:</b> 1:30 pm</p> <p><b>PLEASE PROVIDE A FAX NUMBER IN CASE IT IS NECESSARY TO CONTACT YOU REGARDING YOUR BID:</b></p> <p style="text-align: center;">724-625-3744</p>						

SEE REVERSE SIDE FOR TERMS AND CONDITIONS

SIGNATURE	TELEPHONE	DATE
TITLE	FEIN	ADDRESS CHANGES TO BE NOTED ABOVE

WHEN RESPONDING TO RFQ, INSERT NAME AND ADDRESS IN SPACE ABOVE LABELED 'VENDOR'





State of West Virginia  
 Department of Administration  
 Purchasing Division  
 2019 Washington Street East  
 Post Office Box 50130  
 Charleston, WV 25305-0130

# Request for Quotation

RFQ NUMBER  
**709EC005**

PAGE  
**7**

ADDRESS CORRESPONDENCE TO ATTENTION OF  
**MICHAEL AUSTIN**  
**304-558-2402**

RFQ COPY  
 TYPE NAME/ADDRESS HERE

VENDOR



Golden Equipment Co., Inc.  
 P.O. Box 873  
 Mars, PA 16046-0873

SHIP TO

DIVISION OF HIGHWAYS  
 EQUIPMENT DIVISION  
 ROUTE 33  
 BRUSHY FORK ROAD  
 BUCKHANNON, WV  
 26201 304-472-1750

DATE PRINTED	TERMS OF SALE	SHIP VIA	F.O.B.	FREIGHT TERMS
09/23/2008				

BID OPENING DATE: **10/22/2008** BID OPENING TIME **01:30PM**

LINE	QUANTITY	UOP	CAT NO	ITEM NUMBER	UNIT PRICE	AMOUNT
CONTACT PERSON (PLEASE PRINT CLEARLY):						
----- MARK A. Golden -----						
***** THIS IS THE END OF RFQ 709EC005 ***** TOTAL:						(Each) <u>22,530.00</u>

SEE REVERSE SIDE FOR TERMS AND CONDITIONS

SIGNATURE 	TELEPHONE 1-800-242-1494	DATE 10-22-08
TITLE President	FEIN 25-1537261	ADDRESS CHANGES TO BE NOTED ABOVE

WHEN RESPONDING TO RFQ, INSERT NAME AND ADDRESS IN SPACE ABOVE LABELED 'VENDOR'

WEST VIRGINIA DEPARTMENT OF TRANSPORTATION  
DIVISION OF HIGHWAYS  
EQUIPMENT DIVISION

PROCUREMENT SPECIFICATIONS  
NO. 502-1-B

2 CUBIC YARD 3 TON TRAILER MOUNTED HOT PATCH UNIT

1.0 PURPOSE

It is the purpose of these specifications to describe a 2 Cubic Yard 3 Ton Trailer Mounted Hot Patch Unit (hereinafter referred to as a "unit") to be purchased for use by the West Virginia Division of Highways (DOH) on an Open End Contract basis.

2.0 BIDDING PROCEDURES

**The current purchasing procedures regarding bidding as established by the Department of Administration, Purchasing Division, shall apply.** Failure to submit the "Request for Quotation" forms, complete in its entirety and according to directions indicated, may subject the bidder to disqualification. **Each bid submitted shall also be accompanied by a Bidder's Evaluation Report completed in detail.** Addendums in order, along with exception sheets, should be with Bidder's Evaluation Report. **FAILURE TO SUBMIT THE BIDDER'S EVALUATION REPORT, COMPLETE IN ITS ENTIRETY, MAY RESULT IN AUTOMATIC DISQUALIFICATION.**

3.0 SPECIFICATIONS

The specifications named herein, mandatory and non-mandatory, establish the acceptable level of quality only and are not intended to reflect a preference or favor any particular brand or vendor.

3.1 EXCEPTIONS TO NON-MANDATORY SPECIFICATIONS

Exception to a non-mandatory unit specification may be made by the bidder, providing the exception is not available from the manufacturer. **Any such exception must be noted on the bidder's evaluation report and should be accompanied by supporting documentation/literature from the manufacturer. Any exception must be indicated on a separate attachment to the bidder's evaluation report and labeled as "Exception to Specifications".** The state reserves the right to determine whether the stated exception does or does not reduce the quality and performance of the unit. Failure to provide information for any exceptions may be grounds for rejection of the bid. The state reserves the right to waive minor irregularities in bids or specifications in accordance with §148-1-4(f) of the WV Legislative Rules and Regulations.

### 3.2 MANDATORY SPECIFICATIONS

All specifications preceded by "shall, will, and/or must" or are stated as a "minimum and/or maximum" are mandatory as stated in Purchasing Divisions Policies and Procedures. Any bid failing to meet any mandatory item shall be immediately disqualified. Failure to respond in the appropriate evaluation section may also be grounds for immediate disqualification at the discretion of the State.

A mandatory pre-bid conference is scheduled for this equipment purchase as stated in the RFQ. Vendors having products with variations or exceptions in specified mandatory items are expected to address any such variations or exceptions during the pre-bid conference. **The State shall review and consider any such variation or exception, and may at its sole discretion, issue an addendum to change mandatory specifications deemed to be in the State's best interest. Bids from any vendor failing to attend the mandatory pre-bid shall be disqualified. Bids containing any variation or exception to a mandatory specification that was not addressed during the pre-bid conference and accepted by the issuance of an Addendum shall be disqualified.**

### 4.0 REPRESENTATIVE UNIT FOR TEST

**The successful vendor must (if specified) provide DOH one (1) completed representative unit to be observed and evaluated on each order to insure compliance with specification. If requested, the time period for testing and evaluation shall be seven (7) working days following receipt of the unit. DOH will incur no obligation for deterioration of surfaces, finishes, seals, and mechanical or electrical parts on the unit resulting from operation and testing within the limits of these specifications; nor will DOH incur obligation for damage to the unit resulting from failure to meet specifications when due care and attention is given by DOH and testing is done within the limits of these specifications. Failure of the pilot unit to satisfactorily meet specifications as bid shall be cause for cancellation of the purchase order, and return of the delivered unit along with all associated equipment to the vendor at the vendor's expense.**

### 4.1 CONDITION OF UNIT(S) UPON DELIVERY

**All units must arrive at the prescribed delivery point having been completely preserviced with oil, lubricants, and coolant.** All prescribed precautions pertaining to first operations and break-in of the unit are to be posted conspicuously on the unit for ready observance by the operator.

### 4.2 DELIVERY

Delivery point of the completely assembled representative unit will be the DOH, Equipment Division, Route 33 at Brushy Fork Road, Buckhannon, West Virginia (26201).

The vendor is responsible for guaranteeing delivery of the completed units within the time specified and agreed to by the State. Delivery is preferred within 120 days after receipt of purchase agreement. The vendor is responsible for establishing and coordinating delivery terms with allied manufacturers or suppliers. **Delivery terms shall**

**be stated in the bid and the State reserves the right to accept or negotiate such terms. Failure to reach an agreement may result in rejection of the bid. The successful bidder shall provide their manufacturer's confirmation of the order to the WVDOH contact person within seven (7) working days after receiving the approved purchase order.**

**A completed pilot model for inspection must be provided within 30 calendar days after receipt of the purchase agreement by the successful vendor.**

Delivery is an integral part of this specification and failure to comply will be cause to initiate a D.O.T. Administrative Form WV-82, Vendor Performance Form. The WV-82 Form will provide a means of officially notifying the Purchasing Division and the vendor of unsatisfactory performance; such as late deliveries, poor service, inadequate parts supplies, etc.

The decision to initiate subject Form will be at the sole discretion of the D.O.H. Commissioner's established Equipment Review Board.

Issuance of the WV-82 Vendor Complaint Form on unsatisfactory delivery against any vendor will be cause to refuse to consider similar items from those vendors on future Request For Quotations.

(NOTE: Delivery time could be altered due to labor strikes, severe inclement weather conditions, etc.)

## 5.0 AWARD CRITERIA

- 5.1 DOH will recommend the award in accordance with the RFQ evaluation criteria described in the requisition. **The award shall be made to the lowest unit cost vendor that meets or exceeds the specifications.**

**Prices for the units shall be in quantities of 1-5, 6-10, and 11 and over.** However, for evaluation purposes, we will use quantities 1-5. DOH reserves the right to place multiple orders in any quantity.

## 6.0 SPECIFICATIONS AND GUIDELINES - GENERAL

### 6.1 IDENTIFICATION OF THE UNIT BEING PROPOSED

**The bidder must identify the unit by manufacturer, model, series, and year of manufacture, in the bid to enable identification by DOH in the manufacturer's specifications of the proposed unit.** The bidder will submit complete descriptive literature of the proposed unit, to establish that the bid is the manufacturer's most current model, including latest engineering improvements, which have been, or will imminently be, regularly advertised and sold on the open market. The unit specified herein and offered to be manufactured after January 1, 2008 and be clearly identified and marked with date of manufacture.

### 6.2 OPERATING AND SERVICE MANUALS AND PARTS LISTS

**An operator's manual must be included with each unit upon delivery. A "line sheet" (if applicable) and Equipment Preventative Maintenance Questionnaire (as shown in X6.2 of the Bidder's Evaluation Report) must be with pilot unit upon**

**delivery. In addition, there must be 12 service, shop, or maintenance manuals; ten (10) to be distributed to the Districts and two (2) for the Equipment Division. Also, there must be 14 parts manuals; ten (10) to be distributed to the Districts and four (4) for Equipment Division use. CD ROM is preferred in lieu of parts manuals.**

\* **NOTE: MANUALS SHALL BE DELIVERED UPON COMPLETION OF DELIVERY OF TOTAL UNITS. FAILURE TO DO SO WILL DELAY PAYMENT.**

### 6.3 TRAINING:

Manufacturers and/or dealers will be required to stage a thorough seminar on the subjects of Preventative Maintenance, Operator and Mechanic Training. **In order to keep the operators and mechanics updated, the successful vendor shall conduct training with each purchase order against this open end contract.** Training is preferred within 2 working days after delivery of the pilot unit on the individual purchase order.

**Manufacturers and/or dealers shall be required to furnish the Training Academy with one (1) Operator's Manual to be shipped direct to WVDOH Training Academy, Post Office Box 610, Buckhannon, West Virginia 26201 prior to delivery of the pilot.**

The seminar to be held at the W. Va. Division of Highways, Equipment Division, Buckhannon, West Virginia.

### 6.4 PREVENTIVE MAINTENANCE AND OPERATOR PROCEDURES:

**Manufacturers and/or dealers will be required to submit to the Equipment Division, in addition to the operating and service manuals, booklets and pamphlets explaining the Preventive Maintenance and Operator Procedures to be used by the operators of this equipment, and must include such things as daily prestart inspection procedure, service schedule, and routine maintenance required, safety precautions, etc.**

**The successful vendor shall furnish all training aids; i.e., videos, projectors, etc. required in conducting the training.**

### 6.5 WARRANTY AND SERVICE POLICY

The Manufacturers warranty or service policy is to apply to the unit. Such warranty or service policy is to be recognized at any authorized unit dealer, representing manufacturer of proposed unit throughout the State of West Virginia. The applicable warranty or service policy will not be contingent upon obtaining routine service, lubrication, and servicing of the unit from factory authorized agencies. It will be the responsibility of the bidder to have available labor to repair or replace any defective replacement parts, components and materials, and to have available those replacement parts, components, and/or materials found to be defective during the terms of the warranty period. The bidder should state the labor rates, locations where parts will be stocked, availability of parts, and discounts offered for parts, when terms of the warranty offer a pro-rated cost for parts and labor. In addition, the successful bidder should offer field work to repair or replace defective parts, components, and materials found to be defective during the terms of the warranty and should provide mechanic's travel rates, mileage charges, field mechanic rates, and any surcharge for miscellaneous items, if

applicable, for field work during the warranty period. Submit to Division of Highways any technical or engineering improvements during the term of the warranty.

**The unit must be accompanied upon delivery by the unit's manufacturer's executed warranty or service policy.**

A mandatory minimum two (2) year bumper to bumper basic parts and labor warranty excluding abuse and normal wear items is required for this unit.

**THE "WARRANTY AND SERVICE POLICY QUESTIONNAIRE" ATTACHED IN THE BIDDER'S EVALUATION REPORT MUST BE COMPLETED IN ITS ENTIRETY BY THE SUCCESSFUL BIDDER OR MANUFACTURER PRIOR TO DELIVERY OF THE PILOT MODEL. (SEE SECTION X6.5 OF BIDDER'S EVALUATION REPORT).**

#### 6.6 EVALUATION COMMITTEE REQUIREMENTS

Detailed component specifications, product literature, component models, required for specification compliance determination by the Evaluation Committee should be provided with each bid. Any information supplied that is contrary to/or conflicting with the specifications and/or attached Bidders Evaluation Report may be sufficient cause for rejection of bid.

#### 6.7 UNSPECIFIED ACCESSORIES & FEATURES

**All parts, equipment, accessories, material, design and performance characteristics not specified herein, but which are necessary to provide a complete unit, must be furnished with each unit and required to conform to strength, quality of material, and quality of workmanship to those which are advertised and provided to the market in general by the unit industry.**

**All parts and accessories advertised and regularly supplied as standard shall be included, except those which would represent duplication of these specified, and except those which, by specification, are not to be furnished. All standard safety features, required by Federal and State Law, shall be included.**

#### 7.0 SPECIFICATIONS OF THE QUOTED UNIT ARE AS FOLLOWS:

These specifications describe a 2 Cubic Yard 3 Ton Trailer Mounted Hot Patch which is to be used for patching with hot patch or heated cold mix.

#### 7.1 Container:

- 7.1.1 Unit shall be 2 cubic yard – 3 ton capacity
- 7.1.2 Unit to be double wall construction
- 7.1.3 Interior: 10 gauge

- 7.1.4 Exterior: 12 gauge
- 7.1.5 Insulation: To be 2 inch – 6 lb. density throughout, including rear and top doors
- 7.1.6 Doors:
  - 7.1.6.1 Top loading doors to be strut cylinder assisted
  - 7.1.6.2 Rear shoveling doors to be strut cylinder assisted
- 7.1.7 Shoveling Apron:
  - 7.1.7.1 To be width of the rear door of 10 gauge HR steel
  - 7.1.7.2 To be mounted at the rear
  - 7.1.7.3 **Shall be heated**
- 7.1.8 Floor
  - 7.1.8.1 To be rearward sloping 60 degree angle so as to discharge material
  - 7.1.8.2 To be ¼ inch (steel plate)
- 7.2 Heating System:
  - 7.2.1 To have a single 60,000 BTU burner
  - 7.2.2 To use propane gas vapor fuel, with high limit shut off
  - 7.2.3 To have 100 degrees F – 300 degree F thermostat
  - 7.2.4 To have a 100% shut off valve control by a flame sensing thermo couple
  - 7.2.5 **Must have duct work and passageways to circulate heated air around load**
  - 7.2.6 **Must have a 0 degree – 300 degree F thermometer**
  - 7.2.7 **Unit shall have two (2) 100 lb. (25 gallon) LPG tank with contents gauge**
- 7.3 Trailer:
  - 7.3.1 **Minimum five (5) inch channel construction, single tire, leaf spring, and tandem axle**
  - 7.3.2 **Unit shall have surge brake system with breakaway protection**
  - 7.3.3 **Chassis will have 12,000 lb. GVW rating, with fenders**

- 7.3.4 To have three (3) inch tow eye, adjustable from 28 inches to 34 inches
- 7.3.5 Unit to have 2,000 lb. top wind folding front tongue jack
- 7.3.6 Must have two (2) safety chains**
- 7.3.7 Shall have ICC lighting**
- 7.3.8 To have storage area for shovel, lutes, rakes and small hand tools
- 7.3.9 Paint – manufacturers standard
- 7.4 Options:
  - 7.4.1 Hand torch
    - 7.4.1.1 Shall have pilot with valve control**
    - 7.4.1.2 Capacity of 200,000 BTU
    - 7.4.1.3 Shall have 25 foot hose**
  - 7.4.2 Emulsion Spray Unit:
    - 7.4.2.1 Unit to have emulsion or cutback sprayer for tack oil, PS60, 50/10 diesel
  - 7.4.3 Drip Pan:
    - 7.4.3.1 To have 10 gallon drip pan/waste oil combination mounted under patcher body
    - 7.4.3.2 All necessary valves for draining and cleaning shall be provided**
  - 7.4.4 Shovel Cleaning Compartment:
    - 7.4.4.1 Will be mounted in an easy to use location and be constructed of 16 gauge material with splash guard compartments, drain plug and rain tight cover**
  - 7.4.5 Hose Reels:
    - 7.4.5.1 To have emulsion spray, and hand torch hose reels
    - 7.4.5.2 Hose reels shall be designed to accommodate 25 foot hoses.**
- 7.5 Advertising:
  - 7.5.1 Visible decals or name plates or painted on names representing the Manufacturer or model number or trademark appearing on the exterior surface of the unit should be minimal.



7.6 Paint:

7.6.1 Unit to be painted manufacturer's standard color.

7.6.2 Areas a distinct color for safety reasons should be painted as they normally would be.

7.7 **Vendor must certify that the unit offered will meet or exceed the "Occupational Safety and Health Act of 1970" and subsequent amendments.**

WEST VIRGINIA DEPARTMENT OF TRANSPORTATION  
 DIVISION OF HIGHWAYS  
 EQUIPMENT DIVISION

BIDDER'S EVALUATION REPORT

PROCUREMENT SPECIFICATIONS FOR OPEN END CONTRACT  
 NO. 502-1-B

2 CUBIC YARD 3 TON TRAILER MOUNTED HOT PATCH UNIT

NOTE TO BIDDER: Procurement Specification No. 502-1-B, Paragraph 2.0 recommends the completion and submittal of this Report with your bid. Purpose of this Report is to enable the West Virginia Division of Highways Evaluation Committee to make full and fair evaluation of the bid. Addendums in order, along with a summary of exception as a separate attachment, should be with Bidder's Evaluation Report.  
 FAILURE TO SUBMIT THIS REPORT, COMPLETE IN ITS ENTIRETY, MAY SUBJECT THE BIDDER TO DISQUALIFICATION.

Reference Requisition No.: 709EC005

Bidder's Name: GOLDEN EQUIPMENT CO., INC.

MAIN OFFICE

Address: P.O. Box 873 MARS, PA. 16046

Telephone Number: 1-800-242-1494

Years Bidder has been registered to do business with the State of West Virginia: 20 YRS.

Years Company has been an authorized dealer for proposed unit: 9 YRS.

X3.2 Have you complied with all mandatory specifications? YES  NO

ONE MINOR EXCEPTION 7.1.8.1 45° SLOPE INSTEAD OF 60° / INFORMATION DIAGRAM ENCLOSED  
 X4.2 DELIVERY:

X4.2.1 Delivery date of completed representative unit: 60-90 Calendar Days After  
 Receipt of Purchase Agreement

X4.2.2 Delivery date of balance of completed units: 60-90 Calendar Days After Receipt of  
 Purchase Agreement

## X5.0 AWARD CRITERIA;

## X5.1 Prices for units:

1-5	<u>22,530.<sup>00</sup></u> per unit
6-10	<u>22,230.<sup>00</sup></u> per unit
11 and over	<u>22,030.<sup>00</sup></u> per unit

## X6.0 SPECIFICATIONS - GENERAL

## X6.1 Manufacturer, model, series, and date of manufacture of proposed unit:

SPaulding RS3Is descriptive literature, fully describing proposed unit attached to your bid?  YES  NO

If not, why? \_\_\_\_\_

## X6.2 Will the required number of service manuals, and complete parts list be delivered to the Equipment Division at Buckhannon upon completion of delivery of total units?

 YES  NO

Will the required Equipment Preventive Maintenance Form (Section X6.2 of Bidders Evaluation Report) be provided upon inspection of the pilot unit?

 YES  NO

X6.2  
2-10-00

EQUIPMENT PREVENTATIVE MAINTENANCE QUESTIONNAIRE

THIS FORM MUST BE COMPLETED IN ITS ENTIRETY BY SUCCESSFUL BIDDER OR MANUFACTURER'S TECHNICAL REPRESENTATIVE PRIOR TO DELIVERY OF PILOT MODEL TO THE WVDOH.

DESCRIPTION: 3 TON MAKE: SPaulding  
MODEL: RMVRS 3 YEAR: 2008 PURCHASE AMOUNT: 22,530.00 (EACH)  
ENGINE: MAKE: Honda Tack Sprayer MODEL: Gx 120 FUEL TYPE: GAS  
HORSEPOWER: 4 CYLINDER: \_\_\_\_\_ ENGINE SERIAL: \_\_\_\_\_  
COOLING SYSTEM CAPACITY: \_\_\_\_\_

BELTS: DESCRIPTION: \_\_\_\_\_ PART NUMBERS: \_\_\_\_\_  
\_\_\_\_\_  
\_\_\_\_\_

GVW: 12,000 AXLE CAPACITY: FRONT: 6000 REAR: 6,000

TIRES: FRONT MAKE & SIZE: 235 80 16 R  
REAR MAKE & SIZE: 235 80 16 R

DIMENSIONS OF UNIT: LENGTH: 171" WIDTH: 86" LENGTH: 171"

VENDOR CONTACT PERSON: MARK Golden PHONE: 1-800-242-1494

PARTS:  
BATTERY MAKE: INTERSTATE MODEL: GROUP 24 CCA: 550  
TOP OR SIDE POST: BOTH DIMENSIONS: LENGTH \_\_\_\_\_ WIDTH \_\_\_\_\_ HEIGHT \_\_\_\_\_  
SPARK PLUGS OR FUEL INJECTORS MAKE: \_\_\_\_\_ PART # \_\_\_\_\_  
FUEL PUMP OR INJECTION PUMP MAKE: \_\_\_\_\_ MODEL: \_\_\_\_\_  
ALTERNATOR MAKE: \_\_\_\_\_ PART #: \_\_\_\_\_  
STARTER MAKE: \_\_\_\_\_ PART #: \_\_\_\_\_  
TURBO CHARGER MAKE: \_\_\_\_\_ PART #: \_\_\_\_\_  
TRANS. MAKE: \_\_\_\_\_ MODEL: \_\_\_\_\_ AUTO/MANUAL: \_\_\_\_\_  
HYDRAULIC PUMP MAKE: \_\_\_\_\_ MODEL: \_\_\_\_\_

FILTERS	MAKE	PART NO	LUBRICANT	MANUFACTURER TYPE
OIL	_____	_____	ENGINE	_____
AIR INNER	_____	_____	TRANSMISSION	_____
AIR OUTER	_____	_____	POWER STEERING	_____
FUEL PRIMARY	<u>WIC</u>	<u>7386</u>	HYDRAULIC	_____
FUEL SECONDARY	_____	_____	DIFFERENTIALS	_____
COOLANT	_____	_____	BRAKE FLUID	<u>SAE 40104</u>
HYDRAULIC	_____	_____	COOLANT	_____
OTHER	_____	_____	OTHER	_____

## X6.3 TRAINING:

Will training seminar be conducted on Preventive Maintenance, Operator and Mechanic Training  
 YES  NO

Will you conduct training with each purchase order against this open end contract?  
 YES  NO

Will training be conducted within 2 working days from the delivery of the pilot unit on the individual purchase order?  
 YES  NO

If NO, explain time frame \_\_\_\_\_

Will an Operator's Manual be furnished directly to Training Academy prior to the delivery of the pilot?  
 YES  NO

X6.4 If you are the successful vendor, will you furnish all training aids, i.e., videos, projectors, required in conducting the training?  
 YES  NO *ON SITE TRAINING*

X6.4.1 Will all manuals, booklets, etc. explaining preventive maintenance, operator procedures, and service schedule be delivered with each unit?  
 YES  NO  
 If NO, explain \_\_\_\_\_

## X6.5 WARRANTY AND SERVICE POLICY

Will the warranty and service you provide comply with all areas as stated in Section 6.5 of specifications  
 YES  NO

Is warranty literature attached?  
 YES  NO

Is a minimum two (2) year bumper to bumper basic parts and labor warranty excluding abuse and normal wear items included?  
 YES  NO  
 Describe:  
 \_\_\_\_\_  
 \_\_\_\_\_

## X6.5 WARRANTY AND SERVICE POLICY QUESTIONNAIRE

### THIS FORM MUST BE COMPLETED IN ITS ENTIRETY AND SUBMITTED WITH YOUR BID.

(If additional lines are needed, make copies of form.)

1. Define the terms of the standard warranty. If not offered, so state. (Attach copy)

ENCLOSED

2. Define warranty service to be performed at DOH facilities and warranty service to be performed at manufacturer's representative facility. List name and location of manufacturer's representative.

Golden Equipment Co., Inc 502 Russell St Charleston WV. 25302

Golden Equipment Co., Inc P.O. Box 873 MARS PA. 16046

Golden Equipment Co., Inc 2390 Camp Swatara Rd. MYSTERTON PA. 17067

3. List locations for parts inventofies that are within the State of West Virginia. Also, list availability levels, if known.

THESE UNITS ARE VERY LOW MAINTENANCE. MINIMAL PARTS REQUIRED  
LOCATIONS LISTED ABOVE.

4. During the term of warranty, list the guarantee discount to manufacturer's published list price for parts that bidder will sell the parts to owner.

A.	Terms: Net 30	Manufacturer's published list price less: <u>2.5</u> % discount
B.	Terms: Net 60	Manufacturer's published list price less: <u>N/A</u> % discount
C.	Terms: Net 90	Manufacturer's published list price less: <u>N/A</u> % discount

5. During the term of warranty, will all manufacturers or engineering improvements be submitted to Division of Highways? X YES      NO

6. During the term of warranty, list the guaranteed rates charged for repair to the unit.

A.	Shop Rate	\$ <u>75.00</u> per mechanic hour
B.	Travel Time Charge (Specify if one-way)	\$ <u>75.00</u> per mechanic hour _____ ; port to port <u>X</u>
C.	Mileage Charge (Specify if one-way)	\$ <u>N/A</u> per vehicle mile _____ ; port to port <u>X</u>
D.	Field Mechanic Rate	\$ <u>75.00</u> per mechanic hour
E.	Specify period of time that prices are in effect:	<u>2008-2009</u>
F.	Surcharge for miscellaneous items:	<u>N/A</u> %

## X6.6 EVALUATION COMMITTEE REQUIREMENTS

Is all component specifications, product literature, component models provided for Evaluation Committee bid determination?  YES  NO

**X6.7 Will all parts, equipment, accessories, material, design and performance characteristics not specified herein, but which are necessary to provide a complete unit, be furnished with the unit and conform in strength, quality of material, and quality of workmanship to those which are advertised and provided to the market in general by the unit industry?**

YES  NO

**X6.7.1 Are all parts and accessories adequate and regularly supplied as standard to be included except those which may be duplications of specifications herein, and except these by specification are not to be furnished?**

YES  NO

**X6.7.2 Are all standard safety features that are required by Federal and State statutes of law included?**

YES  NO

## X7.0 SPECIFICATIONS OF THE QUOTED UNIT

The bidder should complete the following schedule in order for the Division to compare the actual bid unit to the specifications. Should the bidder except a requirement, then such exception may be only on the basis that such feature is not offered by the manufacturer. The Division will have the sole discretion as to whether the bidder's substitution meets the requirements of the specifications.

Manufacturer: SPAULING MFG. Model: RS 3

X7.1 Container:

X7.1.1 Is the unit 2 cubic yard - 3 ton capacity  YES  NO

X7.1.2 Is unit double wall construction  YES  NO

X7.1.3 Interior: 10 gauge

X7.1.4 Exterior: 12 gauge

X7.1.5 Insulation: 6 lb density throughout including rear and top doors  YES  NO

X7.1.6 Doors:

X7.1.6.1 Are top loading doors strut cylinder (assisted)  YES  NO

X7.1.6.2 Are rear shoveling doors strut cylinder (assisted)  YES  NO

X7.1.7 Shoveling Apron:

X7.1.7.1 Width of rear door  YES  NO of 1/4 <sup>PLATE</sup> gauge HR steel

- X7.1.7.2 Mounted at the rear  YES  NO
- X7.1.7.3 Heated  YES  NO
- X7.1.8 Floor:
- X7.1.8.1 Rearward sloping 60 degree angle so as to discharge material  YES  NO 45°
- X7.1.8.2 1/4 inch (steel plate) *DIAGRAM ENCLOSED*
- X7.2 Heating System:
- X7.2.1 Single 60,000 BTU burner  YES  NO
- X7.2.2 Propane gas vapor fuel, with high limit shut off  YES  NO
- X7.2.3 Thermostat 0-350° degree F
- X7.2.4 Has a 100% shut off valve control by a flame sensing thermo couple  YES  NO
- X7.2.5 Has duct work and passageways to circulate heated air around load  YES  NO
- X7.2.6 Does it have a 0 degree - 300 degree F thermometer  YES  NO
- X7.2.7 Does unit have two (2) 100 lb. (25 gallon) LPG tank with contents gauge  YES  NO
- X7.3 Trailer:
- X7.3.1 5 inch channel construction, single tire, leaf spring, and tandem axle  YES  NO
- X7.3.2 Unit has surge brake system with breakaway protection  YES  NO
- X7.3.3 Chassis has 12,000 lb. GVW rating, with fenders  YES  NO
- X7.3.4 Has three (3) inch tow eye, adjustable from 28 inches to 34 inches  YES  NO
- X7.3.5 Does unit have 2,000 lb. top wind folding front tongue jack  YES  NO
- X7.3.6 Does unit have two (2) safety chains  YES  NO
- X7.3.7 Does unit have ICC lighting  YES  NO
- X7.3.8 Does unit have storage area for shovel, lutes, rakes, and small hand tools  YES  NO
- X7.3.9 Is paint manufacturers standard  YES  NO



## X7.4 Options:

- X7.4.1 Hand torch  YES  NO
- X7.4.1.1 Pilot with valve control**  YES  NO
- X7.4.1.2 Capacity 200,000 BTU
- X7.4.1.3 25 foot hose**  YES  NO
- X7.4.2 Emulsion Spray unit:
- X7.4.2.1 Does unit have emulsion or cutback sprayer for tack oil, PS60, 50/10 diesel  
 YES  NO
- X7.4.3 Drip Pan:
- X7.4.3.1 Does unit have 10 gallon drip pan/waste oil combination mounted under patcher body  
 YES  NO
- X7.4.3.2 Are all necessary valves for draining and cleaning provided**  YES  NO
- X7.4.4 Shovel Cleaning Compartment:
- X7.4.4.1 Will it be mounted in an easy to use location and be constructed of 16 gauge material with splash guard compartments, drain plug and rain tight cover**  YES  NO
- X7.4.5 Hose Reels:
- X7.4.5.1 Does it have emulsion spray and hand torch hose reels  YES  NO
- X7.4.5.2 Are hose reels designed to accommodate 25 foot hoses**  YES  NO
- X7.5 Advertising:
- X7.5.1 Does unit conform to advertising guidelines  YES  NO
- X7.6 Paint:
- X7.6.1 Is unit manufacturer's standard color  YES  NO
- X7.6.2 Areas a distinct color for safety reasons are painted as normally done  YES  NO
- X7.7 Does unit meet or exceed OSHA of 1970 and amendments**  YES  NO

**VENDOR PREFERENCE CERTIFICATE**

Certification and application\* is hereby made for Preference in accordance with *West Virginia Code*, §5A-3-37. (Does not apply to construction contracts). *West Virginia Code*, §5A-3-37, provides an opportunity for qualifying vendors to request (at the time of bid) preference for their residency status. Such preference is an evaluation method only and will be applied only to the cost bid in accordance with the *West Virginia Code*. This certificate for application is to be used to request such preference. The Purchasing Division will make the determination of the Resident Vendor Preference, if applicable

- 1. **Application is made for 2.5% resident vendor preference for the reason checked:**  
 Bidder is an individual resident vendor and has resided continuously in West Virginia for four (4) years immediately preceding the date of this certification; **or**,  
 Bidder is a partnership, association or corporation resident vendor and has maintained its headquarters or principal place of business continuously in West Virginia for four (4) years immediately preceding the date of this certification; or 80% of the ownership interest of Bidder is held by another individual, partnership, association or corporation resident vendor who has maintained its headquarters or principal place of business continuously in West Virginia for four (4) years immediately preceding the date of this certification; **or**,  
 Bidder is a nonresident vendor which has an affiliate or subsidiary which employs a minimum of one hundred state residents and which has maintained its headquarters or principal place of business within West Virginia continuously for the four (4) years immediately preceding the date of this certification; **or**,
- 2. **Application is made for 2.5% resident vendor preference for the reason checked:**  
 Bidder is a resident vendor who certifies that, during the life of the contract, on average at least 75% of the employees working on the project being bid are residents of West Virginia who have resided in the state continuously for the two years immediately preceding submission of this bid; **or**,
- 3. **Application is made for 2.5% resident vendor preference for the reason checked:**  
 Bidder is a nonresident vendor employing a minimum of one hundred state residents or is a nonresident vendor with an affiliate or subsidiary which maintains its headquarters or principal place of business within West Virginia employing a minimum of one hundred state residents who certifies that, during the life of the contract, on average at least 75% of the employees or Bidder's affiliate's or subsidiary's employees are residents of West Virginia who have resided in the state continuously for the two years immediately preceding submission of this bid; **or**,
- 4. **Application is made for 5% resident vendor preference for the reason checked:**  
 Bidder meets either the requirement of both subdivisions (1) and (2) or subdivision (1) and (3) as stated above; **or**,
- 5. **Application is made for 3.5% resident vendor preference who is a veteran for the reason checked:**  
 Bidder is an individual resident vendor who is a veteran of the United States armed forces, the reserves or the National Guard and has resided in West Virginia continuously for the four years immediately preceding the date on which the bid is submitted; **or**,
- 6. **Application is made for 3.5% resident vendor preference who is a veteran for the reason checked:**  
 Bidder is a resident vendor who is a veteran of the United States armed forces, the reserves or the National Guard, if, for purposes of producing or distributing the commodities or completing the project which is the subject of the vendor's bid and continuously over the entire term of the project, on average at least seventy-five percent of the vendor's employees are residents of West Virginia who have resided in the state continuously for the two immediately preceding years

Bidder understands if the Secretary of Revenue determines that a Bidder receiving preference has failed to continue to meet the requirements for such preference, the Secretary may order the Director of Purchasing to: (a) reject the bid; or (b) assess a penalty against such Bidder in an amount not to exceed 5% of the bid amount and that such penalty will be paid to the contracting agency or deducted from any unpaid balance on the contract or purchase order.

By submission of this certificate, Bidder agrees to disclose any reasonably requested information to the Purchasing Division and authorizes the Department of Revenue to disclose to the Director of Purchasing appropriate information verifying that Bidder has paid the required business taxes, provided that such information does not contain the amounts of taxes paid nor any other information deemed by the Tax Commissioner to be confidential.

Under penalty of law for false swearing (*West Virginia Code*, §61-5-3), Bidder hereby certifies that this certificate is true and accurate in all respects; and that if a contract is issued to Bidder and if anything contained within this certificate changes during the term of the contract, Bidder will notify the Purchasing Division in writing immediately.

Bidder: \_\_\_\_\_ Signed: \_\_\_\_\_

Date: \_\_\_\_\_ Title: \_\_\_\_\_

\*Check any combination of preference consideration(s) indicated above which you are entitled to receive

STATE OF WEST VIRGINIA  
Purchasing Division

# PURCHASING AFFIDAVIT

**VENDOR OWING A DEBT TO THE STATE:**

*West Virginia Code* §5A-3-10a provides that: No contract or renewal of any contract may be awarded by the state or any of its political subdivisions to any vendor or prospective vendor when the vendor or prospective vendor or a related party to the vendor or prospective vendor is a debtor and the debt owed is an amount greater than one thousand dollars in the aggregate.

**PUBLIC IMPROVEMENT CONTRACTS & DRUG-FREE WORKPLACE ACT:**

*West Virginia Code* §21-1D-5 provides that: Any solicitation for a public improvement construction contract shall require each vendor that submits a bid for the work to submit at the same time an affidavit that the vendor has a written plan for a drug-free workplace policy in compliance with Article 1D, Chapter 21 of the West Virginia Code. A public improvement construction contract may not be awarded to a vendor who does not have a written plan for a drug-free workplace policy in compliance with Article 1D, Chapter 21 of the West Virginia Code and who has not submitted that plan to the appropriate contracting authority in timely fashion. For a vendor who is a subcontractor, compliance with Section 5, Article 1D, Chapter 21 of the West Virginia Code may take place before their work on the public improvement is begun.

**ANTITRUST:**

In submitting a bid to any agency for the state of West Virginia, the bidder offers and agrees that if the bid is accepted the bidder will convey, sell, assign or transfer to the state of West Virginia all rights, title and interest in and to all causes of action it may now or hereafter acquire under the antitrust laws of the United States and the state of West Virginia for price fixing and/or unreasonable restraints of trade relating to the particular commodities or services purchased or acquired by the state of West Virginia. Such assignment shall be made and become effective at the time the purchasing agency tenders the initial payment to the bidder.

I certify that this bid is made without prior understanding, agreement, or connection with any corporation, firm, limited liability company, partnership or person or entity submitting a bid for the same materials, supplies, equipment or services and is in all respects fair and without collusion or fraud. I further certify that I am authorized to sign the certification on behalf of the bidder or this bid.

**LICENSING:**

Vendors must be licensed and in good standing in accordance with any and all state and local laws and requirements by any state or local agency of West Virginia, including, but not limited to, the West Virginia Secretary of State's Office, the West Virginia Tax Department, West Virginia Insurance Commission, or any other state agencies or political subdivision. Furthermore, the vendor must provide all necessary releases to obtain information to enable the Director or spending unit to verify that the vendor is licensed and in good standing with the above entities.

**CONFIDENTIALITY:**

The vendor agrees that he or she will not disclose to anyone, directly or indirectly, any such personally identifiable information or other confidential information gained from the agency, unless the individual who is the subject of the information consents to the disclosure in writing or the disclosure is made pursuant to the agency's policies, procedures and rules. Vendors should visit [www.state.wv.us/admin/purchase/privacy](http://www.state.wv.us/admin/purchase/privacy) for the Notice of Agency Confidentiality Policies.

Under penalty of law for false swearing (West Virginia Code §61-5-3), it is hereby certified that the vendor acknowledges the information in this said affidavit and is in compliance with the requirements as stated.

Vendor's Name: Golden Equipment Co, Inc.

Authorized Signature:  Date: 10-22-08



# Golden Equipment Co., Inc.

Main Office ♦ PO Box 873 ♦ Mars, Pennsylvania 16046  
(800) 242-1494 ♦ (724) 625-3100 ♦ Fax (724)625-3744

Public Works

Sewer

Contractors Equipment

## OPTIONS INCLUDED IN BID THAT MAY BE DEDUCTED:

HAND TORCH w/ 25' HOSE	deduct	\$225.00
HEATED TACK OIL TANK w/ AUTO TEMP	deduct	\$1,400.00
HONDA ENGINE w/ TACK PUMP	deduct	\$1,750.00
SOLVENT TANK	deduct	\$150.00
EMULSION HOSE REEL	deduct	\$220.00
PROPANR HOSE TORCH	deduct	\$230.00

Items listed above are already included in the Bid price. Please deduct any options you may feel are not necessary.

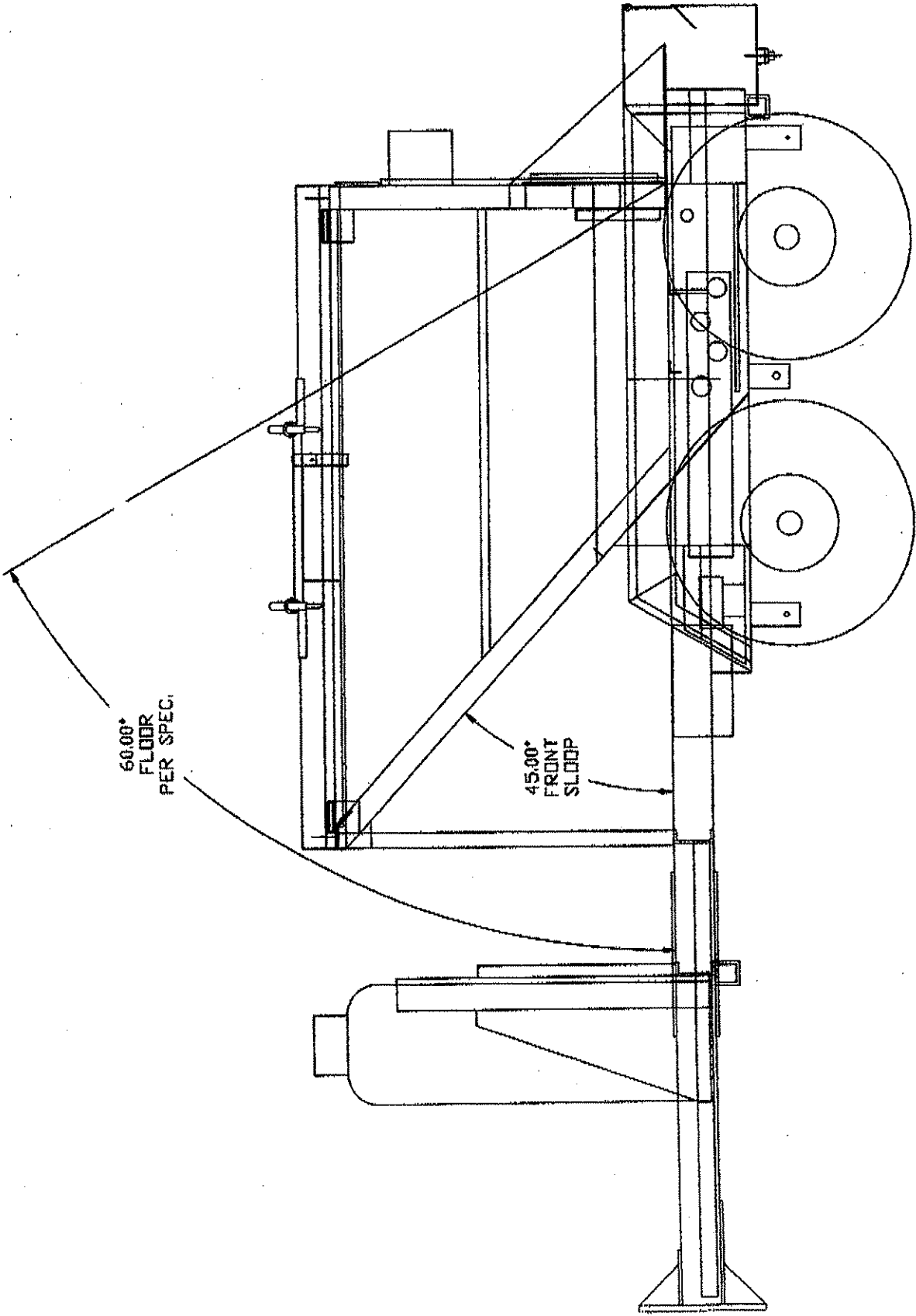

# Spaulding MFG., Inc.

## “RMVRS 4 Ton”

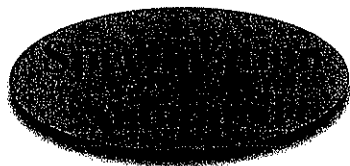

- Weight ..... 3360 lbs.
- Height..... 71 Inches
- Length..... 171 Inches
- Width..... 86 Inches
- Door Opening..... 120 Inches
- Hopper size.....84X86 Inches
- Fuel Souces .....Diesel / Propane
- 115,000 BTU Burner
- Easy Replaceable Combustion Chamber
- 12 Volt Electrical System
- Heavy Duty Frame with Continuous Welds
- Large Hopper Opening for Loading
- Rear Curbside Controls
- Dual Guitine Style Doors

### Contact Info:

Address : Spaulding Mfg., Inc.  
5366 East Rd.  
Saginaw, Mi 48601

Phone: 989-777-4550

Fax: 989-777-7430

E-mail: [sales@spauldingmfg.com](mailto:sales@spauldingmfg.com)

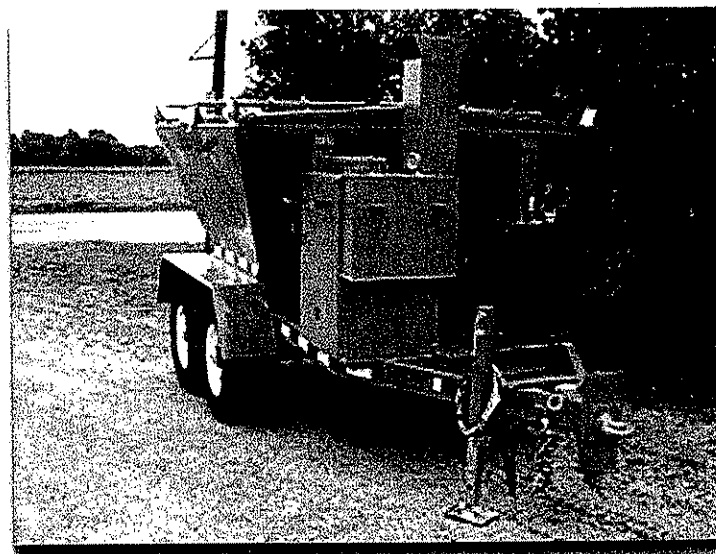
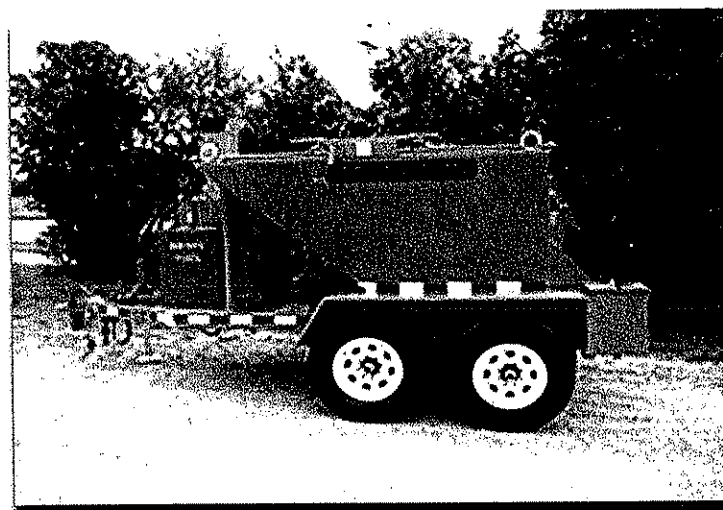

\* Also Available in 3 Ton

# Spaulding MFG., Inc.

## “RMV RS 2 Ton”



The latest product on the Spaulding Mfg., Inc. line is the “RMV RS”. This unique heated hopper trailer comes in 1-4 ton sizes, and is equipped with a new state of the art “surrounding exhaust system”. Powered by either deisel or propane, the “RMV RS” revolutionizes the quality and productivity for patching potholes.

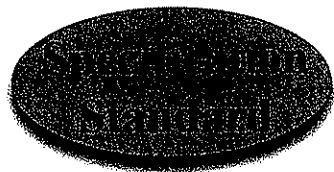

- Weight ..... 2100 lbs.
- Height..... 70 Inches
- Length..... 144 Inches
- Width..... 78 Inches
- Door Opening..... 101 Inches
- Fuel Souces ....Diesel / Propane
- 105,000 BTU Burner
- Easy Replaceable Combustion Chamber
- 12 Volt Electrical System
- Heavy Duty Frame with Continuous Welds
- Large Hopper Opening for Loading
- Rear Curbside Controls
- Dual Guitine Style Doors
- Recessed Lighting

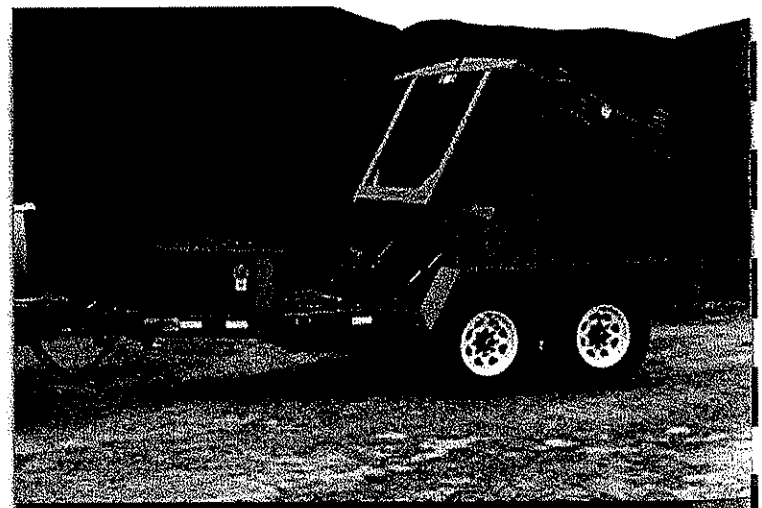
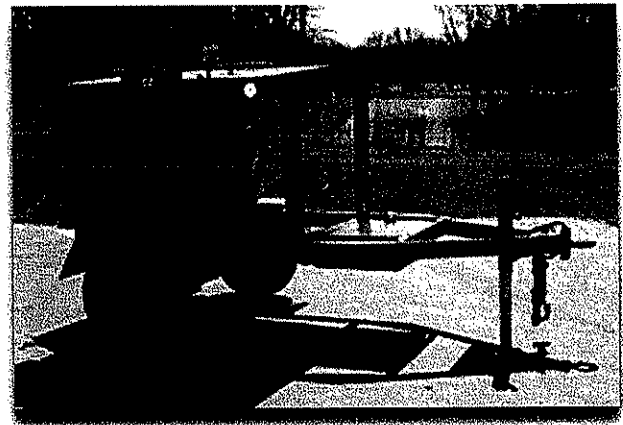

**\*Optional Hydraulic Dumping Hopper**

### Contact Info:

Address · Spaulding Mfg. Inc.

GOLDEN EQUIPMENT CO., INC.  
1-800-242-1494

[www.goldenequipmentcompany.com](http://www.goldenequipmentcompany.com)

E-mail: [sales@spauldingmfg.com](mailto:sales@spauldingmfg.com)

**INTENT**

It is the intent of this specification to provide for the purchase of one (1) new and unused trailer patcher. The specification as listed is based upon a Spaulding Manufacturing, Inc. RMV Road Savor. The City/County's Public Works Department has evaluated different types of trailer patchers and has determined that this product is best suited for the City/County's needs in safety, quality, performance, and standardization. This specification is not to be interpreted as restrictive, but rather as a measure of the safety, quality and performance against which all trailer patchers will be compared.

In comparing proposals, consideration will not be confined to price only. The successful bidder will be one whose product is judged to best serve the interests of the City/County when standardization, price, product, safety, quality and delivery are considered. The City/County reserves the right to reject any or all bids or any part thereof, and to waive any minor technicalities. A contract will be awarded to the bidder submitting the lowest responsible bid meeting the requirements of this specification.

**EQUIVALENT PRODUCT**

Bids will be accepted for consideration on any make or model that is equal or superior to the trailer patcher specified. Decisions of equivalency will be at the sole interpretation of the City/County. A blanket statement that equipment proposed will meet all requirements will not be sufficient to establish equivalence. Original manufacturer's brochures of the proposed unit are to be submitted with the proposal.

All modifications made to the standard production unit described in the manufacturer's brochures must be certified by the manufacturer and submitted with the bid, or the bid will be deemed "non-responsive" and rejected without further review. Bidder must be prepared to demonstrate a unit similar to the one proposed, if requested.

**GENERAL SPECIFICATIONS OF RS 4-TON ASPHALT HAULER-DIESEL**

<b>GENERAL</b>	<b>YES</b>	<b>NO</b>
Tandem Axle trailer mounted asphalt hauler - 4-Ton capacity	_____	_____
Pintle Hitch with 3 inch I.D.	_____	_____
Tail lights, directional, and stoplights recessed into hopper	_____	_____
7-pin plug in connector	_____	_____
Surge brakes on all four wheels/breakaway	_____	_____
6000 lb. heavy wall axle 12000 G.V.W.R.	_____	_____



**HOPPER**

4-Ton Capacity

Double Wall Construction

3 Inch space between material and air walls

1 1/2 Inch space between air and ceramic insulation walls

Air baffles for heat circulation with a variable exhaust system

Insulated wall chambers to hold 2" of high heat temperature  
Ceramic insulation secure 6 lb density

10 gauge center wall heat duct angled inside of hopper

Radiate heat from front to back and side to side

10 Gauge inner walls baffled

12 Gauge outer walls

1/4 Inch plate floor baffled heat chambers under floor

work table - 26 aprox" off ground w/ 8 x 14.5 tires

Allows full hopper access from the ground

Dual 14 x 17 x 18 door opening's with tee  
handle to open with one hand sliding roller style guide

Automatic action to lock flip action to release

Door opening provides full access to 38 inches in width of 1/4 plate floor  
for removing asphalt with shovel from the ground with heated shoveling plate

Continuous welds the full length of the floor bottom, sides,  
inside and out of hopper

Top loading doors 40 inches in width and 109 inches to top of

door when fully extended

peak styled doors are insulated, bushing hinged with grease insert  
and removable from hopper. When opened form a funnel for loading

Steel outer skins framed on square tubing with angle iron reinforced

Removable manually retractable, centered handles, 3/4" Schedule 80 pipe  
with strut cylinder assist

7 inch grab handles, solid round stock with no open ends

_____	_____
_____	_____
_____	_____
_____	_____
_____	_____

**YES**

**NO**

**TRAILER**

3-1/4" OD Axles, rated at 6000# each

2-inch wide Slipper spring leaf spring suspension

Wheels – heavy duty commercial tires -- 8 x 14.5 or 235/80/16R

2000 lb. Park Jack with steel landing foot plate

Overall length 159 inches

Height 72 3/4 inches

Width of hopper 88 inches

Weight – 3000lbs. without fuel

Safety chains are 70 Grade Transport chains DOT approved

3/8 Clevis Hooks with safety clip

Trailer Frame is constructed of 5 inch channel

4 Cross members on the horizontal and 2 on the vertical

Fenders fabricated of heavy steel with full steel skirt

Tail lights, LED directional, stop and turn flush to hopper to prevent asphalt  
Build up ICC lighting

_____	_____
_____	_____
_____	_____
_____	_____
_____	_____
_____	_____
_____	_____
_____	_____
_____	_____
_____	_____
_____	_____
_____	_____

Gusset construction hitch adjuster

\_\_\_\_\_

Holes for adjusting the height, 18.5" to 34"

\_\_\_\_\_

YES

NO

**SOLVENT TANK**

Solvent tank for shovels located off back fender flush to  
Top of fender with dual flip access doors spring snap latch  
next access door and bolts on – holds two shovels

\_\_\_\_\_

Square in Shape 13x13x16 inches

\_\_\_\_\_

11.5 Gallon Capacity

\_\_\_\_\_

12 GA Steel

\_\_\_\_\_

Spring bolt automatic lock drop spill proof lid

\_\_\_\_\_

**HEAT SYSTEM**

Combustion chamber 100 sq in mounted on to front of hopper

\_\_\_\_\_

Removable bottom drop box insulated with inspection cover

\_\_\_\_\_

2 – 100 Lb propane tanks secured to 7 ga bracket with full metal back

\_\_\_\_\_

Pressure gauge shows continuous working pressure

\_\_\_\_\_

Fuel solenoids powered by 12-volt system

\_\_\_\_\_

12vdc solenoid controls flow of fuel to burner

\_\_\_\_\_

Spark ignition system powered by 12-volt system

\_\_\_\_\_

Automatic shut down system safety feature

\_\_\_\_\_

Sensor rod monitors flame in burner

\_\_\_\_\_

Spark ignition to supply to electrodes to ignite fuel

\_\_\_\_\_

Power on switch in nema 3r lockable box bolted on hopper	_____	_____
Digital snap in thermostat no rewiring shows set temp and actual temp	_____	_____
Controlled by a 1/16 Din microprocessor-based auto temp control	_____	_____
Interstate deep cycle battery set in battery box ready for recharge system	_____	_____

**PAINT**

Orange or yellow	_____	_____
All bolt on parts disassemble from chassis to paint	_____	_____
All wiring , l.p. parts , regulators ect. Not to be painted	_____	_____
All parts and trailer and hopper sandblasted and ground smooth edges	_____	_____
Auto primer on all parts and entire unit	_____	_____
Two coats of urethane finish topcoat for 6 mil thickness	_____	_____

**MANUALS**

- 2 – Manuals
- 2 – Operational Video CD
- 2 – Year Warranty

**OPTIONS:**

Hand torch to deliver 200,000 BTU with pilot and valve control with holder for easy access  
Along with 25 ft of hose on a retractable hose reel which bolts on to the ¼ plate pad \_\_\_\_\_

**Emulsion Spray unit**

The emulsion spray unit shall be designed for tack oil and hold 50 gallon. It will be insulated and heated with it own separate burner. The automatic temperature control system will turn the tank off when

The desired temperature is meet and will re-ignite after a 20 degree drop.  
 It will have a 10 gallon flush tank to clean the pump . 25 ft hose with hose reel and  
 Lines. They are powered by a 4 HP Honda engine with a 6 to 1 gear reducer  
 A 10 gallon drip pan with a clean out is also for the waste from the above.

**Shovel Cleaning Compartment**  
 Is made of 12 ga and holds two shovels, it has a splash guard and a 1.5 inch drain plug  
 And a rain tight cover with front shovel entry.

**SERVICE AND TRAINING**

Vendors shall have parts and service facility within a reasonable distance from the City/County Garage.  
 State location and distance. \_\_\_\_\_

A qualified technician shall provide complete training to the City/County personnel at the City/County  
 Garage. Training shall include safety, operation, maintenance and service. \_\_\_\_\_

**REFERENCES**

Bidder shall state length of time in service as an authorized Dealer and/or Manufacturer for the product  
 being proposed. Bidder shall state length of time Manufacturer has been building product being  
 proposed and location of manufacturing  
 facility. \_\_\_\_\_

Bidder shall submit name, address, responsible party and phone number of not less than (10) Wisconsin  
 based Municipal owners of comparable models to that being offered, who have used such models over a  
 (5) Year span. If none, state so.

1. \_\_\_\_\_
2. \_\_\_\_\_
3. \_\_\_\_\_
4. \_\_\_\_\_
5. \_\_\_\_\_
6. \_\_\_\_\_
7. \_\_\_\_\_
8. \_\_\_\_\_
9. \_\_\_\_\_
10. \_\_\_\_\_

**EXCEPTIONS AND DEVIATIONS**

Bidder shall fully describe very variance, exception, and/or deviation. If additional space is needed,  
 please include additional sheets.

**PROPOSAL FORM**

The undersigned declares that they have carefully examined the requirements of specifications contained herein, and propose to furnish and deliver to the City/County the apparatus listed below. The City/County may, at its sole discretion, buy the proposed product that is in the best interest of the City/County.

**ONE (1) NEW UNUSED FOUR (2) TON TRAILER "HOT PATCHER", MODEL RMV OR EQUIVALENT**

<b>MANUFACTURER</b>	<b>MODEL</b>
<b>PURCHASE PRICE:@ \$</b>	<b>TOTAL \$</b>
<b>(IN WORDS)</b>	
<b>TRADE VALUE</b>	
<b>NET PRICE AFTER TRADE</b>	
<b>DELIVERY AFTER RECEIPT OF ORDER</b>	
<b>WARRANTY</b>	

**NAME OF COMPANY** \_\_\_\_\_

**ADDRESS** \_\_\_\_\_

**TELEPHONE** \_\_\_\_\_

**FAX** \_\_\_\_\_

**EMAIL** \_\_\_\_\_

**AUTHORIZED REPRESENTATIVE** \_\_\_\_\_

**AUTHORIZED SIGNATURE** \_\_\_\_\_

**TITLE** \_\_\_\_\_

**DATE** \_\_\_\_\_

By: **SPAULDING MFG., INC.**

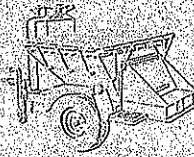

Manufactured by:  
**Spaulding, MFG., Inc.**

5366 East Road  
Saginaw, Michigan 48601  
(989) 777-4550 • (989) 777-0699  
Fax (989) 777-7430  
E-mail: sales@spauldingmfg.com  
website: www.spauldingmfg.com

# 4 TON RMV "HOT PATCHER" Road Maintenance Vehicle

## SPECIFICATIONS- STANDARD

Capacity.....4 ton  
Height.....74 Inches  
Length .....15 Feet  
Width outside fender/fender....73 Inches  
Weight Unladen .....3800 lbs.

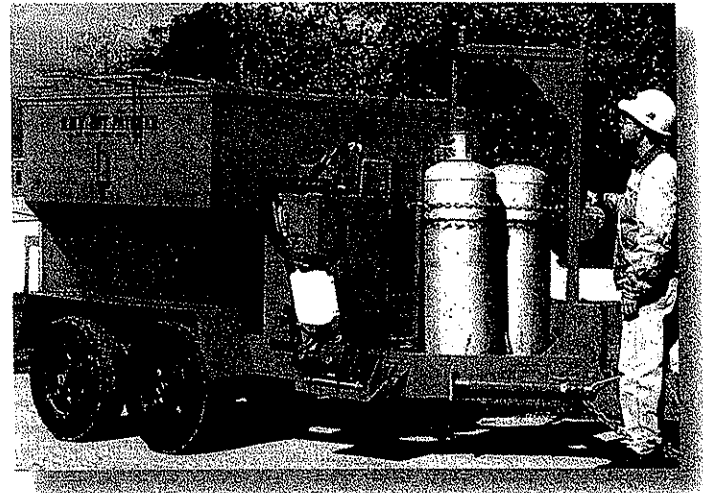

## STANDARD FEATURES

- Insulated Hopper and Doors
- Triple Wall Construction
- Continuous Welds
- Tandem Axles with Electric Brakes
- Heated Unloading Platform
- Adjustable Hitch-12 Positions
- L.P. Tank Rack for 2 Tanks (cylinders not included)
- Excess Flow Control Valves L.P.
- 150,000 BTU Stainless Steel Burner L.P. Gas
- Commercial Rated Tires
- Heavy Duty Rims
- Bolt on Fenders
- Solvent Tank for Shovels
- Retractable Handles on Top Doors
- Safety Latch Top Doors
- U.L. Rated L.P. Gas Hose



Bulldog 500 Vibratory Roller

By: **SPAULDING MFG., INC.**



Manufactured by:  
**Spaulding, MFG., Inc.**

5366 East Road  
Saginaw, Michigan 48601  
(989) 777-4550 • (989) 777-0699  
Fax (989) 777-7430  
E-mail: sales@spauldingmfg.com  
website: www.spauldingmfg.com

# **4** RMV 'HOT PATCHER' Road Maintenance Vehicle

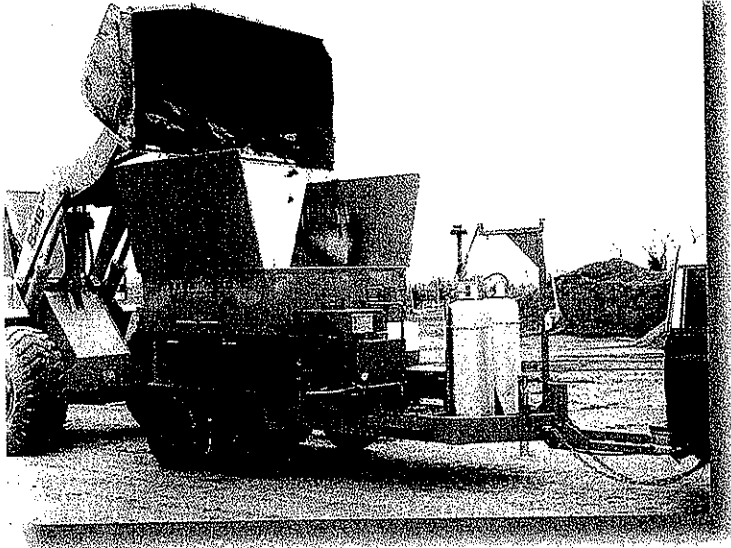

## **OPTIONAL EQUIPMENT**

- Automatic Temperature Control
- Beacon Warning Light/Strobe/Arrow Stick
- Hydraulic Surge Brakes
- Temperature Control Insulated Tack Tank
- Spray Wand and Hose for Tack Tank
- Hand Held Torch with Hose
- Hoist with Area for Roller or Plate Tamper
- Vibratory Roller
- 15 Gallon Water Tank
- Thermometer Dial at Back of Hopper
- Reclaimer Hopper
- Battery Pack
- Generator

## **4** Reclaimer

### **FUEL SOURCES**

- L.P. Gas
- Diesel
- Electric
- CNG

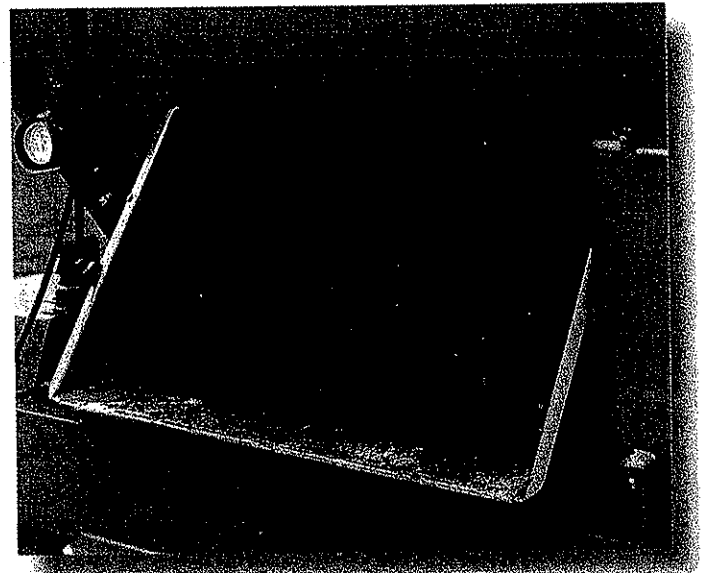

(Reclaimed Asphalt from above photo)

Dealer:

**GOLDEN EQUIPMENT CO., INC.**  
1-800-242-1494  
www.goldenequipmentcompany.com

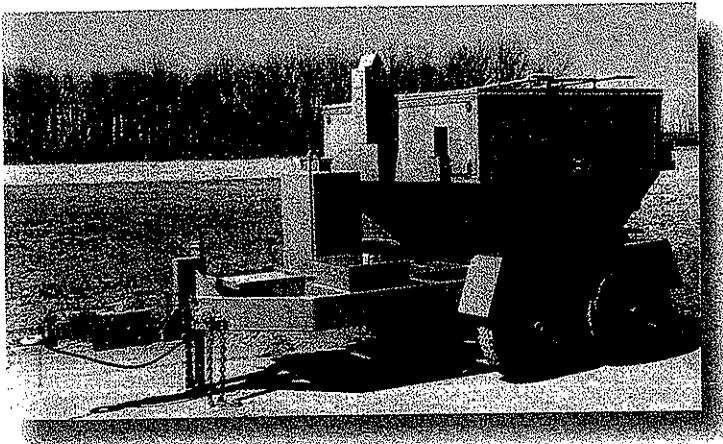

## **4** Diesel



## WARRANTY

Spaulding Manufacturing warrants to the original purchaser for a period of 24 months after the date of delivery, the replacement of any parts found defective on material or workmanship. The obligation of the company is limited to repairing or replacing any defective part returned to the company and will not be responsible for consequential damages or any further loss by reason of such defect. Repairs or replacements to be made F.O.B. Saginaw Michigan or a point designated by the company. This warranty does not obligate the company to bear cost of labor or transportation charges in connection with replacement or repair of defective parts. Nor does this warranty apply to machines on which unauthorized repairs or alterations have been made or to products not manufactured by the company except to the extent of the warranty given by the original manufacturer.



# Golden Equipment Co., Inc.

Public Works

Sewer

Contractors Equipment

## 1-800-242-1494

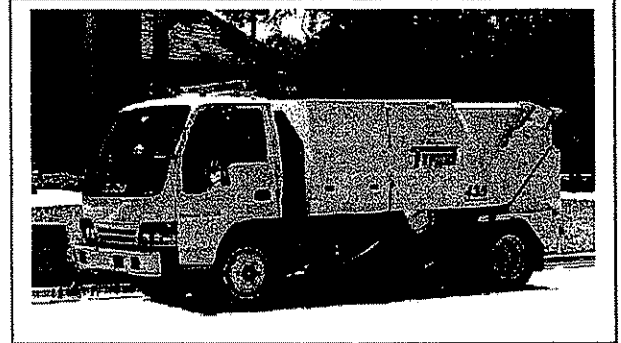
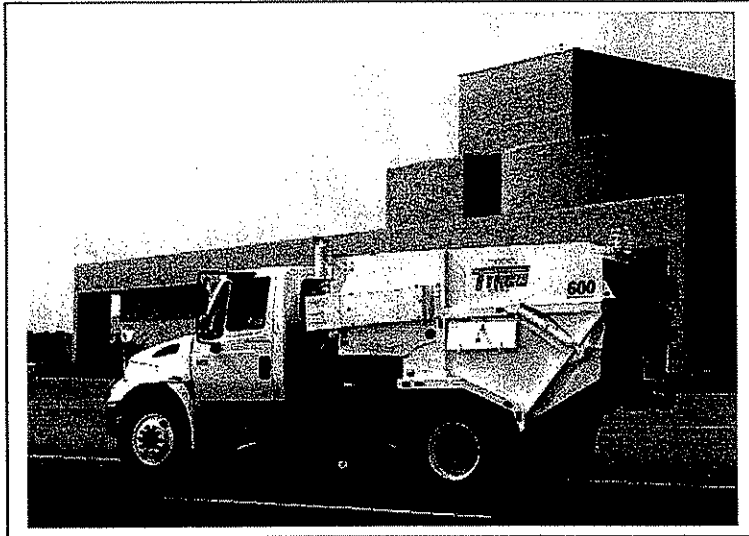

**STREET SWEEPERS**

**\*\*GOLDEN EQUIPMENT CO., INC.** has been offering the finest quality Sales, Service and Parts for over 20 years. We offer convenient **NO BID PROGRAMS** for our Municipal customers and flexible financing and leasing options. Our knowledgeable staff can provide information on our Top of the line products such as STREET SWEEPERS, SEWER FLUSHERS and SANITARY TV INSPECTION EQUIPMENT to name a few. Refurbished / preowned equipment / rentals and contracting are also available.

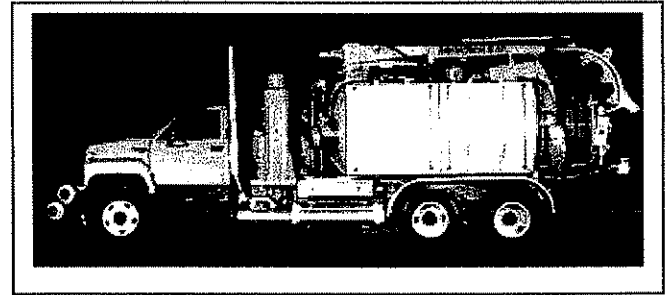
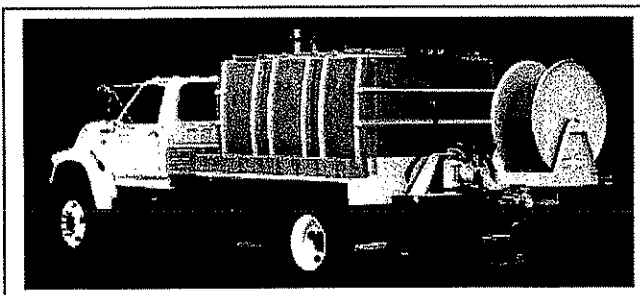
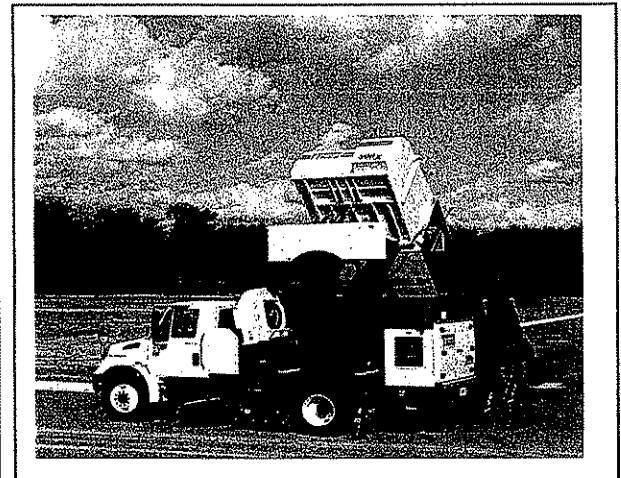

**COMBINATION SEWER CLEANERS**

\* Sales

\* Service

\* Parts

Myerstown, PA

Mars, PA

Charleston, WV

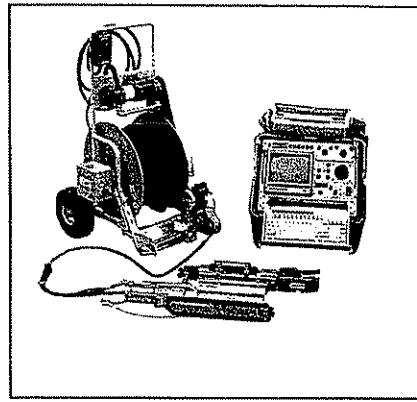

**SEWER LINE INSPECTION  
EQUIPMENT**

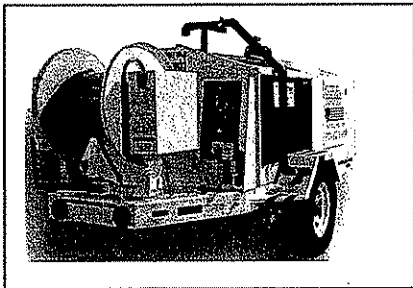

**GOLDEN EQUIPMENT CO., INC.**

**SERVING PENNSYLVANIA AND WEST VIRGINIA**

**1-800-242-1494**

[www.goldenequipmentcompany.com](http://www.goldenequipmentcompany.com)

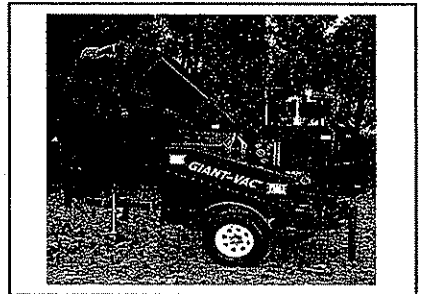

**\*\*\*PREOWNED EQUIPMENT AND CONTRACTING AVAILABLE\*\*\***

**HYDROJETTERS**

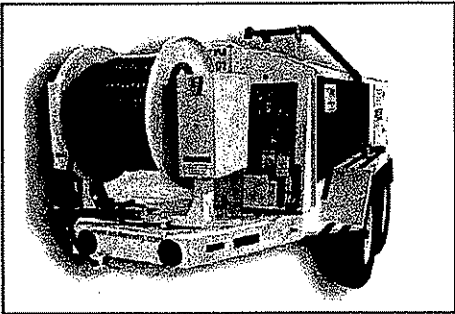

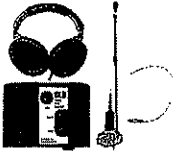

**LEAK DETECTORS**



**LOCATORS**

**LEAF LOADERS / CHIPPERS**

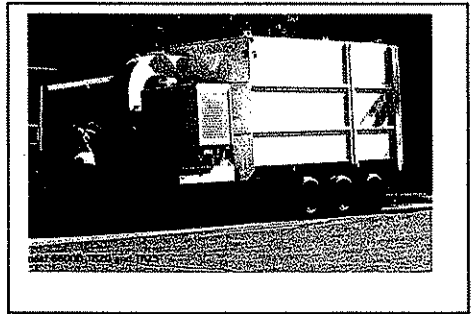

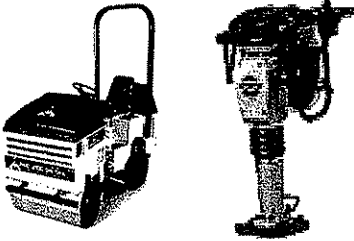

**CONSTRUCTION  
EQUIPMENT**

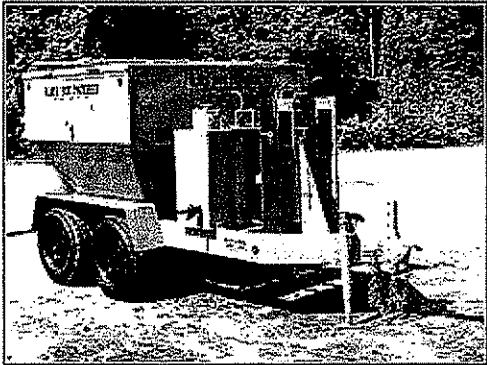

**HOT PATCHERS**



**SPREADERS/SNOW PLOWS**



## **History of Golden Equipment Co., Inc.**

Golden Equipment Co. Inc. was started in the mid 70's in Mars Pennsylvania, selling and servicing sewer cleaners and accessories. In the mid 80's Golden Equipment Co., was incorporated and a second office was opened in Charleston West Virginia. At this time Golden Equipment Co. picked up the Tymco street sweeper account and other accounts affiliated with the public works departments. Due to Golden Equipment Company's reputation in sales and service our manufacturers we represent have expanded our territories to include all of PA. and WV. With this commitment from our manufacturers, and in order to better serve our customers in Eastern PA, we opened our third office in Myerstown PA in the late 90's.

Golden Equipment Co., Inc. has over 25 years of experience in the sales and service of municipal equipment. We now have three locations and sixteen full time employees. Our service departments have mobile maintenance vehicles with factory trained technicians to make any necessary adjustments or repairs at the customers facility.

**Golden Equipment Company, Inc**

<http://www.goldenequipmentcompany.com>