



State of West Virginia  
 Department of Administration  
 Purchasing Division  
 2019 Washington Street East  
 Post Office Box 50130  
 Charleston, WV 25305-0130

# Request for Quotation

RFQ NUMBER  
**709EC003**

PAGE  
**1**

ADDRESS: CORRESPONDENCE TO ATTENTION OF  
**MICHAEL AUSTIN**  
**304-558-2402**

**\*709051756**      **304-346-5301**  
**WV TRACTOR COMPANY**  
**PO BOX 473**  
  
**CHARLESTON WV 25322**

**DIVISION OF HIGHWAYS**  
**EQUIPMENT DIVISION**  
**ROUTE 33**  
**BRUSHY FORK ROAD**  
**BUCKHANNON, WV**  
**26201**      **304-472-1750**

DATE PRINTED <b>08/26/2008</b>	TERMS OF SALE <b>Net 30 Days</b>	SHIP VIA <b>Truck</b>	F.O.B. <b>Buckhannon</b>	FREIGHT TERMS <b>Prepaid</b>
-----------------------------------	-------------------------------------	--------------------------	-----------------------------	---------------------------------

BID OPENING DATE: **09/17/2008**      BID OPENING TIME **01:30PM**

LINE	QUANTITY	UOP	CAT NO	ITEM NUMBER	UNIT PRICE	AMOUNT
<b>0001</b>	<b>1</b>	<b>EA</b>		<b>755-35 LAYTON F525</b>		
<p><b>HYDRAULIC CONTROLLED, TOWED TYPE, BITUMINOUS PAVER</b></p> <p><b>OPEN END CONTRACT</b></p> <p><b>TO PROVIDE HYDRAULIC CONTROLLED, TOWED TYPE BITUMINOUS PAVER (LAYTON BOX) FOR THE WEST VIRGINIA DIVISION OF HIGHWAYS PER THE ATTACHED SPECIFICATIONS.</b></p> <p><b>THERE WILL BE A MANDATORY PRE-BID CONFERENCE AT THE WEST VIRGINIA DIVISION OF HIGHWAYS EQUIPMENT DIVISION BUCKHANNON, WV 26201 AT 10:00 AM ON 09/11/08. FAILURE TO ATTEND THE PRE-BID WILL RESULT IN BID DISQUALIFICATION.</b></p> <p><b>QUESTIONS: WRITTEN QUESTIONS MUST BE RECEIVED BY CLOSE OF BUSINESS (5:00 AM EST) ON MONDAY 09/08/08. SEND YOUR QUESTIONS TO: PURCHASING DIVISION ATTENTION MICHAEL AUSTIN 2019 WASHINGTON ST. E., CHARLESTON, WV 25305</b></p> <p><b>QUESTIONS MAY BE SENT VIA FAX, E-MAIL OR REGULAR MAIL            E-MAIL: MICHAEL.D.AUSTIN@WV.GOV            FAX: 304-558-4115</b></p> <p><b>IT IS THE VENDORS RESPONSIBILITY TO VERIFY THAT THEIR QUESTIONS HAVE BEEN RECEIVED BY CALLING 304-558-2402.</b></p> <p><b>EXHIBIT 2</b></p>						

**RECEIVED**  
**2008 OCT -8 P 12:33**  
**PURCHASING DIVISION**  
**STATE OF WV**

SEE REVERSE SIDE FOR TERMS AND CONDITIONS			
SIGNATURE <i>Michael D. Austin</i>	TELEPHONE <b>346-5301</b>	DATE <b>9/22-08</b>	
TITLE <b>President</b>	FEIN <b>550621655</b>	<b>ADDRESS CHANGES TO BE NOTED ABOVE</b>	

WHEN RESPONDING TO RFQ, INSERT NAME AND ADDRESS IN SPACE ABOVE LABELED 'VENDOR'

**GENERAL TERMS & CONDITIONS  
REQUEST FOR QUOTATION (RFQ) AND REQUEST FOR PROPOSAL (RFP)**

1. Awards will be made in the best interest of the State of West Virginia.
2. The State may accept or reject in part, or in whole, any bid.
3. All quotations are governed by the *West Virginia Code* and the *Legislative Rules* of the Purchasing Division.
4. Prior to any award, the apparent successful vendor must be properly registered with the Purchasing Division and have paid the required \$125 fee.
5. All services performed or goods delivered under State Purchase Order/Contracts are to be continued for the term of the Purchase Order/Contracts, contingent upon funds being appropriated by the Legislature or otherwise being made available. In the event funds are not appropriated or otherwise available for these services or goods, this Purchase Order/Contract becomes void and of no effect after June 30.
6. Payment may only be made after the delivery and acceptance of goods or services.
7. Interest may be paid for late payment in accordance with the *West Virginia Code*.
8. Vendor preference will be granted upon written request in accordance with the *West Virginia Code*.
9. The State of West Virginia is exempt from federal and state taxes and will not pay or reimburse such taxes.
10. The Director of Purchasing may cancel any Purchase Order/Contract upon 30 days written notice to the seller.
11. The laws of the State of West Virginia and the *Legislative Rules* of the Purchasing Division shall govern all rights and duties under the Contract, including without limitation the validity of this Purchase Order/Contract.
12. Any reference to automatic renewal is hereby deleted. The Contract may be renewed only upon mutual written agreement of the parties.
13. **BANKRUPTCY:** In the event the vendor/contractor files for bankruptcy protection, this Contract may be deemed null and void, and terminated without further order.
14. **HIPAA BUSINESS ASSOCIATE ADDENDUM:** The West Virginia State Government HIPAA Business Associate Addendum (BAA), approved by the Attorney General, and available online at the Purchasing Division's web site (<http://www.state.wv.us/admin/purchase/vrc/hipaa.htm>) is hereby made part of the agreement. Provided that, the Agency meets the definition of a Cover Entity (45 CFR §160.103) and will be disclosing Protected Health Information (45 CFR §160.103) to the vendor.
15. **WEST VIRGINIA ALCOHOL & DRUG-FREE WORKPLACE ACT:** If this Contract constitutes a public improvement construction contract as set forth in Article 1D, Chapter 21 of the West Virginia Code ("The West Virginia Alcohol and Drug-Free Workplace Act"), then the following language shall hereby become part of this Contract: "The contractor and its subcontractors shall implement and maintain a written drug-free workplace policy in compliance with the West Virginia Alcohol and Drug-Free Workplace Act, as set forth in Article 1D, Chapter 21 of the West Virginia Code. The contractor and its subcontractors shall provide a sworn statement in writing, under the penalties of perjury, that they maintain a valid drug-free work place policy in compliance with the West Virginia and Drug-Free Workplace Act. It is understood and agreed that this Contract shall be cancelled by the awarding authority if the Contractor: 1) Fails to implement its drug-free workplace policy; 2) Fails to provide information regarding implementation of the contractor's drug-free workplace policy at the request of the public authority; or 3) Provides to the public authority false information regarding the contractor's drug-free workplace policy."

---

**INSTRUCTIONS TO BIDDERS**

1. Use the quotation forms provided by the Purchasing Division.
2. **SPECIFICATIONS:** Items offered must be in compliance with the specifications. Any deviation from the specifications must be clearly indicated by the bidder. Alternates offered by the bidder as **EQUAL** to the specifications must be clearly defined. A bidder offering an alternate should attach complete specifications and literature to the bid. The Purchasing Division may waive minor deviations to specifications.
3. Complete all sections of the quotation form.
4. Unit prices shall prevail in case of discrepancy.
5. All quotations are considered F.O.B. destination unless alternate shipping terms are clearly identified in the quotation.
6. **BID SUBMISSION:** All quotations must be delivered by the bidder to the office listed below prior to the date and time of the bid opening. Failure of the bidder to deliver the quotations on time will result in bid disqualifications: Department of Administration, Purchasing Division, 2019 Washington Street East, P.O. Box 50130, Charleston, WV 25305-0130



State of West Virginia  
 Department of Administration  
 Purchasing Division  
 2019 Washington Street East  
 Post Office Box 50130  
 Charleston, WV 25305-0130

# Request for Quotation

RFQ NUMBER
709EC003

PAGE
2

ADDRESS CORRESPONDENCE TO ATTENTION OF
MICHAEL AUSTIN 304-558-2402

VENDOR

\*709051756      304-346-5301  
 WV TRACTOR COMPANY  
 PO BOX 473  
  
 CHARLESTON WV 25322

SHIP TO

DIVISION OF HIGHWAYS  
 EQUIPMENT DIVISION  
 ROUTE 33  
 BRUSHY FORK ROAD  
 BUCKHANNON, WV  
 26201      304-472-1750

DATE PRINTED	TERMS OF SALE	SHIP VIA	F.O.B.	FREIGHT TERMS
08/26/2008				

BID OPENING DATE: **09/17/2008**      BID OPENING TIME **01:30PM**

LINE	QUANTITY	UOP	CAT NO	ITEM NUMBER	UNIT PRICE	AMOUNT
<p>LIFE OF CONTRACT: THIS CONTRACT BECOMES EFFECTIVE ON ..... AND EXTENDS FOR A PERIOD OF ONE (1) YEAR OR UNTIL SUCH "REASONABLE TIME" THEREAFTER AS IS NECESSARY TO OBTAIN A NEW CONTRACT OR RENEW THE ORIGINAL CONTRACT. THE "REASONABLE TIME" PERIOD SHALL NOT EXCEED TWELVE (12) MONTHS. DURING THIS "REASONABLE TIME" THE VENDOR MAY TERMINATE THIS CONTRACT FOR ANY REASON UPON GIVING THE DIRECTOR OF PURCHASING THIRTY (30) DAYS WRITTEN NOTICE.</p> <p>UNLESS SPECIFIC PROVISIONS ARE STIPULATED IN THIS CONTRACT DOCUMENT, THE TERMS, CONDITIONS, AND PRICING SET HEREIN ARE FIRM FOR THE LIFE OF THE CONTRACT.</p> <p>RENEWAL: THIS CONTRACT MAY BE RENEWED UPON THE MUTUAL WRITTEN CONSENT OF THE SPENDING UNIT AND VENDOR, SUBMITTED TO THE DIRECTOR OF PURCHASING THIRTY (30) DAYS PRIOR TO THE EXPIRATION DATE. SUCH RENEWAL SHALL BE IN ACCORDANCE WITH THE TERMS AND CONDITIONS OF THE ORIGINAL CONTRACT AND SHALL BE LIMITED TO TWO (2) ONE (1) YEAR PERIODS.</p> <p>CANCELLATION: THE DIRECTOR OF PURCHASING RESERVES THE RIGHT TO CANCEL THIS CONTRACT IMMEDIATELY UPON WRITTEN NOTICE TO THE VENDOR IF THE COMMODITIES AND/OR SERVICES SUPPLIED ARE OF AN INFERIOR QUALITY OR DO NOT CONFORM WITH THE SPECIFICATIONS OF THE BID AND CONTRACT HEREIN.</p> <p>OPEN MARKET CLAUSE: THE DIRECTOR OF PURCHASING MAY AUTHORIZE A SPENDING UNIT TO PURCHASE ON THE OPEN MARKET, WITHOUT THE FILING OF A REQUISITION OR COST ESTIMATE, ITEMS SPECIFIED ON THIS CONTRACT FOR IMMEDIATE DELIVERY IN EMERGENCIES DUE TO UNFORESEEN CAUSES (INCLUDING BUT NOT LIMITED TO DELAYS IN TRANSPORTATION OR AN UNANTICIPATED INCREASE IN THE VOLUME OF WORK).</p>						

SEE REVERSE SIDE FOR TERMS AND CONDITIONS

SIGNATURE	TELEPHONE	DATE
TITLE	FEIN	ADDRESS CHANGES TO BE NOTED ABOVE

WHEN RESPONDING TO RFQ, INSERT NAME AND ADDRESS IN SPACE ABOVE LABELED 'VENDOR'



State of West Virginia  
 Department of Administration  
 Purchasing Division  
 2019 Washington Street East  
 Post Office Box 50130  
 Charleston, WV 25305-0130

# Request for Quotation

RFO NUMBER  
**709EC003**

PAGE  
**3**

ADDRESS CORRESPONDENCE TO ATTENTION OF:  
**MICHAEL AUSTIN**  
**304-558-2402**

**VENDOR**  
 \*709051756 304-346-5301  
**WV TRACTOR COMPANY**  
**PO BOX 473**  
**CHARLESTON WV 25322**

**SHIP TO**  
**DIVISION OF HIGHWAYS**  
**EQUIPMENT DIVISION**  
**ROUTE 33**  
**BRUSHY FORK ROAD**  
**BUCKHANNON, WV**  
**26201 304-472-1750**

DATE PRINTED	TERMS OF SALE	SHIP VIA	FOB	FREIGHT TERMS
08/26/2008				

BID OPENING DATE: **09/17/2008** BID OPENING TIME **01:30PM**

LINE	QUANTITY	UOP	CAT NO	ITEM NUMBER	UNIT PRICE	AMOUNT
<p><b>QUANTITIES:</b> QUANTITIES LISTED IN THE REQUISITION ARE APPROXIMATIONS ONLY, BASED ON ESTIMATES SUPPLIES BY THE STATE SPENDING UNIT. IT IS UNDERSTOOD AND AGREED THAT THE CONTRACT SHALL COVER THE QUANTITIES ACTUALLY ORDERED FOR DELIVERY DURING THE TERM OF CONTRACT, WHETHER MORE OR LESS THAN THE QUANTITIES SHOWN.</p> <p><b>ORDERING PROCEDURE:</b> SPENDING UNIT(S) SHALL ISSUE A WRITTEN EQUIPMENT CONTRACT ORDER (FORM NUMBER WV-35) FOR COMMODITIES COVERED BY THIS CONTRACT. THE ORIGINAL WV-35 MUST BE SENT TO THE PURCHASING DIVISION OF THE DEPARTMENT OF ADMINISTRATION. AFTER APPROVAL AND ENCUMBRANCE, ONE COPY OF THE PURCHASE ORDER WILL BE RETURNED TO THE SPENDING UNIT AND ONE COPY FORWARDED TO THE VENDOR AS AUTHORIZATION FOR SHIPMENT. NO ORDER IS VALID UNLESS APPROVED AND ENCUMBERED BY THE PURCHASING DIVISION.</p> <p><b>BANKRUPTCY:</b> IN THE EVENT THE VENDOR/CONTRACTOR FILES FOR BANKRUPTCY PROTECTION, THIS CONTRACT IS AUTOMATICALLY NULL AND VOID, AND IS TERMINATED WITHOUT FURTHER ORDER.</p> <p>REV. 9/98</p> <p>EXHIBIT 6</p> <p><b>PRICE ADJUSTMENT PROVISION:</b>            THE STATE OF WEST VIRGINIA WILL CONSIDER BIDS THAT CONTAIN PROVISIONS FOR PRICE ADJUSTMENTS PRIOR TO THE ORIGINAL EXPIRATION OF THE CONTRACT, PROVIDED THAT SUCH PRICE ADJUSTMENT COVERS BOTH UPWARD AND DOWNWARD MOVEMENT OF THE COMMODITY PRICE, AND THAT ADJUSTMENT IS BASED ON THE "PASS THROUGH" INCREASE OR DECREASE OF</p>						

SEE REVERSE SIDE FOR TERMS AND CONDITIONS

SIGNATURE	TELEPHONE	DATE
TITLE	FEIN	ADDRESS CHANGES TO BE NOTED ABOVE

WHEN RESPONDING TO RFQ, INSERT NAME AND ADDRESS IN SPACE ABOVE LABELED 'VENDOR'



State of West Virginia  
 Department of Administration  
 Purchasing Division  
 2019 Washington Street East  
 Post Office Box 50130  
 Charleston, WV 25305-0130

# Request for Quotation

RFQ NUMBER  
**709EC003**

PAGE  
**4**

ADDRESS CORRESPONDENCE TO ATTENTION OF  
**MICHAEL AUSTIN**  
**304-558-2402**

VENDOR

\*709051756      304-346-5301  
 WV TRACTOR COMPANY  
 PO BOX 473  
  
 CHARLESTON WV 25322

SHIP TO

DIVISION OF HIGHWAYS  
 EQUIPMENT DIVISION  
 ROUTE 33  
 BRUSHY FORK ROAD  
 BUCKHANNON, WV  
 26201      304-472-1750

DATE PRINTED	TERMS OF SALE	SHIP VIA	F.O.B.	FREIGHT TERMS
08/26/2008				

BID OPENING DATE: **09/17/2008**      BID OPENING TIME **01:30PM**

LINE	QUANTITY	UOP	CAT NO	ITEM NUMBER	UNIT PRICE	AMOUNT
				<p>RAW MATERIALS AND/OR LABOR, WHICH MAKE UP ALL OR A SUBSTANTIAL PART OF A PRODUCT. ADJUSTMENTS ARE TO BE BASED UPON AN ACTUAL DOLLAR FIGURE, NOT A PERCENTAGE. ALL PRICE ADJUSTMENT REQUESTS MUST BE SUBSTANTIATED IN A MANNER ACCEPTABLE TO THE DIRECTOR PURCHASING, E.G. GOVERNMENTAL BENCH MARKS, GENERAL MARKET INCREASE, PUBLISHED PRICE LISTS. SUCH REQUESTS FOR AND INCREASE SHOULD BE RECEIVED IN WRITING BY THE DIRECTOR OF PURCHASING AT LEAST 30 DAYS IN ADVANCE OF THE EFFECTIVE DATE OF THE INCREASE. ANY TIME THE VENDOR REQUESTS A PRICE ADJUSTMENT, THE PURCHASING DIVISION MAY EITHER ACCEPT THE PRICE ADJUSTMENT AND AMEND THE CONTRACT ACCORDINGLY OR REJECT THE ADJUSTMENT IN ITS ENTIRETY AND CANCEL THE CONTRACT.</p>		
					709EC003	
				REQUISITION NO.: .....		
				ADDENDUM ACKNOWLEDGEMENT		
				I HEREBY ACKNOWLEDGE RECEIPT OF THE FOLLOWING CHECKED ADDENDUM(S) AND HAVE MADE THE NECESSARY REVISIONS TO M PROPOSAL, PLANS AND/OR SPECIFICATION, ETC.		
				ADDENDUM NO.'S:		
				NO. 1    x		
				NO. 2    x		
				NO. 3    X		
				NO. 4    .....		

SEE REVERSE SIDE FOR TERMS AND CONDITIONS

SIGNATURE	TELEPHONE	DATE
TITLE	FEIN	ADDRESS CHANGES TO BE NOTED ABOVE

WHEN RESPONDING TO RFQ, INSERT NAME AND ADDRESS IN SPACE ABOVE LABELED 'VENDOR'



State of West Virginia  
 Department of Administration  
 Purchasing Division  
 2019 Washington Street East  
 Post Office Box 50130  
 Charleston, WV 25305-0130

# Request for Quotation

RFQ NUMBER  
**709EC003**

PAGE  
**5**

ADDRESS CORRESPONDENCE TO ATTENTION OF  
**MICHAEL AUSTIN**  
**304-558-2402**

**VENDOR**  
 \*709051756      304-346-5301  
**WV TRACTOR COMPANY**  
**PO BOX 473**  
**CHARLESTON WV 25322**

**SHIP TO**  
**DIVISION OF HIGHWAYS**  
**EQUIPMENT DIVISION**  
**ROUTE 33**  
**BRUSHY FORK ROAD**  
**BUCKHANNON, WV**  
**26201      304-472-1750**

DATE PRINTED <b>08/26/2008</b>	TERMS OF SALE	SHIP VIA	F.O.B.	FREIGHT TERMS
-----------------------------------	---------------	----------	--------	---------------

BID OPENING DATE: **09/17/2008**      BID OPENING TIME **01:30PM**

LINE	QUANTITY	UOP	CAT NO	ITEM NUMBER	UNIT PRICE	AMOUNT
	<b>NO. 5</b>					
<p>I UNDERSTAND THAT FAILURE TO CONFIRM THE RECEIPT OF THE ADDENDUM(S) MAY BE CAUSE FOR REJECTION OF BIDS.</p> <p>VENDOR MUST CLEARLY UNDERSTAND THAT ANY VERBAL REPRESENTATION MADE OR ASSUMED TO BE MADE DURING ANY ORAL DISCUSSION HELD BETWEEN VENDOR'S REPRESENTATIVES AND ANY STATE PERSONNEL IS NOT BINDING. ONLY THE INFORMATION ISSUED IN WRITING AND ADDED TO THE SPECIFICATIONS BY AN OFFICIAL ADDENDUM IS BINDING.</p> <p style="text-align: right;"> <i>Garrett Gray</i>            .....            SIGNATURE            .....            West Virginia Tractor Company            .....            COMPANY            .....            9-22-08            .....            DATE         </p> <p>REV. 11/96</p> <p style="text-align: center;"><b>VENDOR PREFERENCE CERTIFICATE</b></p> <p>CERTIFICATION AND APPLICATION* IS HEREBY MADE FOR PREFERENCE IN ACCORDANCE WITH WEST VIRGINIA CODE, 5A-3-37 (DOES NOT APPLY TO CONSTRUCTION CONTRACTS).</p> <p>A. APPLICATION IS MADE FOR 2.5% PREFERENCE FOR THE REASON CHECKED:</p> <p>( ) BIDDER IS AN INDIVIDUAL RESIDENT VENDOR AND</p>						

SEE REVERSE SIDE FOR TERMS AND CONDITIONS

SIGNATURE	TELEPHONE	DATE
TITLE	FEIN	ADDRESS CHANGES TO BE NOTED ABOVE

WHEN RESPONDING TO RFQ, INSERT NAME AND ADDRESS IN SPACE ABOVE LABELED 'VENDOR'



State of West Virginia  
 Department of Administration  
 Purchasing Division  
 2019 Washington Street East  
 Post Office Box 50130  
 Charleston, WV 25305-0130

# Request for Quotation

RFQ NUMBER  
**709EC003**

PAGE  
**6**

ADDRESS CORRESPONDENCE TO ATTENTION OF  
**MICHAEL AUSTIN**  
**304-558-2402**

VENDOR

\*709051756      304-346-5301  
 WV TRACTOR COMPANY  
 PO BOX 473  
  
 CHARLESTON WV 25322

SHIP TO

DIVISION OF HIGHWAYS  
 EQUIPMENT DIVISION  
 ROUTE 33  
 BRUSHY FORK ROAD  
 BUCKHANNON, WV  
 26201      304-472-1750

DATE PRINTED <b>08/26/2008</b>	TERMS OF SALE	SHIP VIA	F.O.B.	FREIGHT TERMS
-----------------------------------	---------------	----------	--------	---------------

BID OPENING DATE: **09/17/2008**      BID OPENING TIME **01:30PM**

LINE	QUANTITY	UOP	CAT NO	ITEM NUMBER	UNIT PRICE	AMOUNT
<p>HAS RESIDED CONTINUOUSLY IN WEST VIRGINIA FOR FOUR (4) YEARS IMMEDIATELY PRECEDING THE DATE OF THIS CERTIFICATION; OR</p> <p>( XX ) BIDDER IS A PARTNERSHIP, ASSOCIATION OR CORPORATION RESIDENT VENDOR AND HAS MAINTAINED ITS HEAD-QUARTERS OR PRINCIPAL PLACE OF BUSINESS CONTINUOUSLY IN WEST VIRGINIA FOR FOUR (4) YEARS IMMEDIATELY PRECEDING THE DATE OF THIS CERTIFICATION; OR 80% OF THE OWNERSHIP INTEREST OF BIDDER IS HELD BY ANOTHER INDIVIDUAL, PARTNERSHIP, ASSOCIATION OR CORPORATION RESIDENT VENDOR WHO HAS MAINTAINED ITS HEADQUARTERS OR PRINCIPAL PLACE OF BUSINESS CONTINUOUSLY IN WEST VIRGINIA FOR FOUR (4) YEARS IMMEDIATELY PRECEDING THE DATE OF THIS CERTIFICATION; OR</p> <p>( ) BIDDER IS A CORPORATION NONRESIDENT VENDOR WHICH HAS AN AFFILIATE OR SUBSIDIARY WHICH EMPLOYS A MINIMUM OF ONE HUNDRED STATE RESIDENTS AND WHICH HAS MAINTAINED ITS HEADQUARTERS OR PRINCIPAL PLACE OF BUSINESS WITHIN WEST VIRGINIA CONTINUOUSLY FOR THE FOUR (4) YEARS IMMEDIATELY PRECEDING THE DATE OF THIS CERTIFICATION.</p> <p>B. APPLICATION IS MADE FOR 2.5% PREFERENCE FOR THE REASON CHECKED:</p> <p>( XX ) BIDDER IS A RESIDENT VENDOR WHO CERTIFIES THAT, DURING THE LIFE OF THE CONTRACT, ON AVERAGE AT LEAST 75% OF THE EMPLOYEES WORKING ON THE PROJECT BEING BID ARE RESIDENTS OF WEST VIRGINIA WHO HAVE RESIDED IN THE STATE CONTINUOUSLY FOR THE TWO YEARS IMMEDIATELY PRECEDING SUBMISSION OF THIS BID;          OR          ( ) BIDDER IS A NONRESIDENT VENDOR EMPLOYING A MINIMUM OF ONE HUNDRED STATE RESIDENTS OR IS A</p>						

SEE REVERSE SIDE FOR TERMS AND CONDITIONS

SIGNATURE	TELEPHONE	DATE
-----------	-----------	------

TITLE	FEIN	ADDRESS CHANGES TO BE NOTED ABOVE
-------	------	-----------------------------------

WHEN RESPONDING TO RFQ, INSERT NAME AND ADDRESS IN SPACE ABOVE LABELED 'VENDOR'



State of West Virginia  
 Department of Administration  
 Purchasing Division  
 2019 Washington Street East  
 Post Office Box 50130  
 Charleston, WV 25305-0130

# Request for Quotation

RFQ NUMBER  
**709EC003**

PAGE  
**7**

ADDRESS CORRESPONDENCE TO ATTENTION OF  
**MICHAEL AUSTIN**  
**304-558-2402**

**VENDOR**  
 \*709051756      304-346-5301  
**WV TRACTOR COMPANY**  
**PO BOX 473**  
  
**CHARLESTON WV 25322**

**SHIP TO**  
**DIVISION OF HIGHWAYS**  
**EQUIPMENT DIVISION**  
**ROUTE 33**  
**BRUSHY FORK ROAD**  
**BUCKHANNON, WV**  
**26201**      **304-472-1750**

DATE PRINTED <b>08/26/2008</b>	TERMS OF SALE	SHIP VIA	F.O.B.	FREIGHT TERMS
-----------------------------------	---------------	----------	--------	---------------

BID OPENING DATE: **09/17/2008**      BID OPENING TIME **01:30PM**

LINE	QUANTITY	UOP	CAT NO	ITEM NUMBER	UNIT PRICE	AMOUNT
<p>NONRESIDENT VENDOR WITH AN AFFILIATE OR SUBSIDIARY WHICH MAINTAINS ITS HEADQUARTERS OR PRINCIPAL PLACE OF BUSINESS WITHIN WEST VIRGINIA EMPLOYING A MINIMUM OF ONE HUNDRED STATE RESIDENTS WHO CERTIFIES THAT, DURING THE LIFE OF THE CONTRACT, ON AVERAGE AT LEAST 75% OF THE EMPLOYEES OR BIDDERS' AFFILIATE'S OR SUBSIDIARY'S EMPLOYEES ARE RESIDENTS OF WEST VIRGINIA WHO HAVE RESIDED IN THE STATE CONTINUOUSLY FOR THE TWO YEARS IMMEDIATELY PRECEDING SUBMISSION OF THIS BID.</p> <p>BIDDER UNDERSTANDS IF THE SECRETARY OF TAX &amp; REVENUE DETERMINES THAT A BIDDER RECEIVING PREFERENCE HAS FAILED TO CONTINUE TO MEET THE REQUIREMENTS FOR SUCH PREFERENCE, THE SECRETARY MAY ORDER THE DIRECTOR OF PURCHASING TO: (A) RESCIND THE CONTRACT OR PURCHASE ORDER ISSUED; OR (B) ASSESS A PENALTY AGAINST SUCH BIDDER IN AN AMOUNT NOT TO EXCEED 5% OF THE BID AMOUNT AND THAT SUCH PENALTY WILL BE PAID TO THE CONTRACTING AGENCY OR DEDUCTED FROM ANY UNPAID BALANCE ON THE CONTRACT OR PURCHASE ORDER.</p> <p>BY SUBMISSION OF THIS CERTIFICATE, BIDDER AGREES TO DISCLOSE ANY REASONABLY REQUESTED INFORMATION TO THE PURCHASING DIVISION AND AUTHORIZES THE DEPARTMENT OF TAX AND REVENUE TO DISCLOSE TO THE DIRECTOR OF PURCHASING APPROPRIATE INFORMATION VERIFYING THAT BIDDER HAS PAID THE REQUIRED BUSINESS TAXES, PROVIDED THAT SUCH INFORMATION DOES NOT CONTAIN THE AMOUNTS OF TAXES PAID NOR ANY OTHER INFORMATION DEEMED BY THE TAX COMMISSIONER TO BE CONFIDENTIAL.</p> <p>UNDER PENALTY OF LAW FOR FALSE SWEARING (WEST VIRGINIA CODE 61-5-3), BIDDER HEREBY CERTIFIES THAT THIS CERTIFICATE IS TRUE AND ACCURATE IN ALL RESPECTS; AND THAT IF A CONTRACT IS ISSUED TO BIDDER AND IF ANYTHING CONTAINED WITHIN THIS CERTIFICATE CHANGES DURING THE</p>						

SEE REVERSE SIDE FOR TERMS AND CONDITIONS

SIGNATURE	TELEPHONE	DATE
-----------	-----------	------

TITLE	FEIN	ADDRESS CHANGES TO BE NOTED ABOVE
-------	------	-----------------------------------

WHEN RESPONDING TO RFQ, INSERT NAME AND ADDRESS IN SPACE ABOVE LABELED 'VENDOR'





State of West Virginia  
 Department of Administration  
 Purchasing Division  
 2019 Washington Street East  
 Post Office Box 50130  
 Charleston, WV 25305-0130

# Request for Quotation

RFO NUMBER
709EC003

PAGE
8

ADDRESS CORRESPONDENCE TO ATTENTION OF
MICHAEL AUSTIN 304-558-2402

VENDOR

\*709051756      304-346-5301  
 WV TRACTOR COMPANY  
 PO BOX 473  
 CHARLESTON WV 25322

SHIP TO

DIVISION OF HIGHWAYS  
 EQUIPMENT DIVISION  
 ROUTE 33  
 BRUSHY FORK ROAD  
 BUCKHANNON, WV  
 26201      304-472-1750

DATE PRINTED	TERMS OF SALE	SHIP VIA	F.O.B.	FREIGHT TERMS
08/26/2008				

BID OPENING DATE: **09/17/2008**      BID OPENING TIME **01:30PM**

LINE	QUANTITY	UOP	CAT NO	ITEM NUMBER	UNIT PRICE	AMOUNT
<p>TERM OF THE CONTRACT, BIDDER WILL NOTIFY THE PURCHASING DIVISION IN WRITING IMMEDIATELY.</p> <p style="text-align: center;">West Virginia Tractor Company</p> <p>BIDDER: -----</p> <p style="text-align: center;">9-22-08</p> <p>DATE: -----</p> <p>SIGNED: <i>Gayle Gray</i></p> <p style="text-align: center;">President</p> <p>TITLE: -----</p> <p>* CHECK ANY COMBINATION OF PREFERENCE CONSIDERATION(S) IN EITHER "A" OR "B", OR BOTH "A" AND "B" WHICH YOU ARE ENTITLED TO RECEIVE. YOU MAY REQUEST UP TO THE MAXIMUM 5% PREFERENCE FOR BOTH "A" AND "B". (REV. 12/00)</p> <p style="text-align: center;">NOTICE</p> <p>A SIGNED BID MUST BE SUBMITTED TO:</p> <p style="text-align: center;">DEPARTMENT OF ADMINISTRATION          PURCHASING DIVISION          BUILDING 15          2019 WASHINGTON STREET, EAST          CHARLESTON, WV 25305-0130</p> <p>THE BID SHOULD CONTAIN THIS INFORMATION ON THE FACE OF THE ENVELOPE OR THE BID MAY NOT BE CONSIDERED:</p> <p>SEALED BID</p>						

SEE REVERSE SIDE FOR TERMS AND CONDITIONS

SIGNATURE	TELEPHONE	DATE
TITLE	FEIN	ADDRESS CHANGES TO BE NOTED ABOVE

WHEN RESPONDING TO RFQ, INSERT NAME AND ADDRESS IN SPACE ABOVE LABELED 'VENDOR'



State of West Virginia  
 Department of Administration  
 Purchasing Division  
 2019 Washington Street East  
 Post Office Box 50130  
 Charleston, WV 25305-0130

# Request for Quotation

RFQ NUMBER
709EC003

PAGE
9

ADDRESS CORRESPONDENCE TO ATTENTION OF:
MICHAEL AUSTIN 304-558-2402

SHIP TO

\*709051756      304-346-5301  
 WV TRACTOR COMPANY  
 PO BOX 473  
 CHARLESTON WV 25322

SHIP TO

DIVISION OF HIGHWAYS  
 EQUIPMENT DIVISION  
 ROUTE 33  
 BRUSHY FORK ROAD  
 BUCKHANNON, WV  
 26201      304-472-1750

DATE PRINTED	TERMS OF SALE	SHIP VIA	F.O.B.	FREIGHT TERMS
08/26/2008				

BID OPENING DATE: **09/17/2008**      BID OPENING TIME **01:30PM**

LINE	QUANTITY	UOP	CAT. NO.	ITEM NUMBER	UNIT PRICE	AMOUNT
BUYER:				33		
RFQ. NO.:				709EC003		
BID OPENING DATE:				9-24-08		
BID OPENING TIME:				1:30 PM		
PLEASE PROVIDE A FAX NUMBER IN CASE IT IS NECESSARY TO CONTACT YOU REGARDING YOUR BID:						
				346-5305		
CONTACT PERSON (PLEASE PRINT CLEARLY):						
				Gary Grady		
***** THIS IS THE END OF RFQ 709EC003 ***** TOTAL:						_____

SEE REVERSE SIDE FOR TERMS AND CONDITIONS

SIGNATURE	TELEPHONE	DATE
TITLE	FEIN	ADDRESS CHANGES TO BE NOTED ABOVE

WHEN RESPONDING TO RFQ, INSERT NAME AND ADDRESS IN SPACE ABOVE LABELED 'VENDOR'

WEST VIRGINIA DEPARTMENT OF TRANSPORTATION  
DIVISION OF HIGHWAYS  
EQUIPMENT DIVISION

BIDDER'S EVALUATION REPORT

PROCUREMENT SPECIFICATIONS FOR OPEN END CONTRACT  
NO. 546-2-G

HYDRAULIC CONTROLLED, TOWED TYPE, BITUMINOUS PAVER  
(LAYTON BOX)

NOTE TO BIDDER: Procurement Specification No. 546-2-G, Paragraph 2.0 recommends the completion and submittal of this Report with your bid. Purpose of this Report is to enable the West Virginia Division of Highways Evaluation Committee to make full and fair evaluation of the bid. Addendums in order, along with a summary of exception as a separate attachment, should be with Bidder's Evaluation Report. FAILURE TO SUBMIT THIS REPORT, COMPLETE IN ITS ENTIRETY; MAY SUBJECT THE BIDDER TO DISQUALIFICATION.

Reference Requisition No.: 709EC003

Bidder's Name: West Virginia Tractor Company

Address: P.O. Box 473 Charleston, WV 25322

Telephone Number: 346-5301

Years Bidder has been registered to do business with the State of West Virginia: 26 YRS.

Years Company has been an authorized dealer for proposed unit: 26 YRS.

X3.2 Have you complied with all mandatory specifications?  YES  NO

X4.2 DELIVERY:

X4.2.1 Delivery date of completed representative unit: 30 Calendar Days After  
Receipt of Purchase Agreement

X4.2.2 Delivery date of balance of completed units: 90-120 Calendar Days After Receipt of  
Purchase Agreement

**Bidder's Evaluation Report available for download on Purchasing's Web site at [www.state.wv.us/admin/purchase](http://www.state.wv.us/admin/purchase)**

7

**X5.0 AWARD CRITERIA:**

<b>X5.1 Prices for units:</b>	1-10	\$37,400	per unit
	11-20	\$37,400	per unit
	21 and over	\$37,400	per unit

**X6.0 SPECIFICATIONS - GENERAL****X6.1 Manufacturer, model, series, and date of manufacture of proposed unit:**

Eayton F525

2008 and later as ordered

Is descriptive literature, fully describing proposed unit attached to your bid?  YES  NO

If not, why? \_\_\_\_\_

**X6.2 Will the required number of service manuals, and complete parts list be delivered to the Equipment Division at Buckhannon upon completion of delivery of total units?** YES  NO**Will the required Equipment Preventive Maintenance Form (Section X6.2 of Bidders Evaluation Report) be provided upon inspection of the pilot unit?** YES  NO

X6.2  
2-10-00

**EQUIPMENT PREVENTATIVE MAINTENANCE QUESTIONNAIRE**

THIS FORM MUST BE COMPLETED IN ITS ENTIRETY BY SUCCESSFUL BIDDER OR MANUFACTURER'S TECHNICAL REPRESENTATIVE PRIOR TO DELIVERY OF PILOT MODEL TO THE WVDOH.

DESCRIPTION: \_\_\_\_\_ MAKE: \_\_\_\_\_

MODEL: \_\_\_\_\_ YEAR: \_\_\_\_\_ PURCHASE AMOUNT: \_\_\_\_\_

ENGINE: MAKE: \_\_\_\_\_ MODEL: \_\_\_\_\_ FUEL TYPE: \_\_\_\_\_

HORSEPOWER: \_\_\_\_\_ CYLINDER: \_\_\_\_\_ ENGINE SERIAL: \_\_\_\_\_

COOLING SYSTEM CAPACITY: \_\_\_\_\_

BELTS: DESCRIPTION: \_\_\_\_\_ PART NUMBERS: \_\_\_\_\_

\_\_\_\_\_  
\_\_\_\_\_

GVW: \_\_\_\_\_ AXLE CAPACITY: \_\_\_\_\_ FRONT: \_\_\_\_\_ REAR: \_\_\_\_\_

TIRES: FRONT MAKE & SIZE: \_\_\_\_\_

REAR MAKE & SIZE: \_\_\_\_\_

DIMENSIONS OF UNIT: LENGTH: \_\_\_\_\_ WIDTH: \_\_\_\_\_ LENGTH: \_\_\_\_\_

VENDOR CONTACT PERSON: \_\_\_\_\_ PHONE: \_\_\_\_\_

**PARTS:**

BATTERY MAKE: \_\_\_\_\_ MODEL: \_\_\_\_\_ CCA: \_\_\_\_\_

TOP OR SIDE POST: \_\_\_\_\_ DIMENSIONS: LENGTH \_\_\_\_\_ WIDTH \_\_\_\_\_ HEIGHT \_\_\_\_\_

SPARK PLUGS OR FUEL INJECTORS MAKE: \_\_\_\_\_ PART # \_\_\_\_\_

FUEL PUMP OR INJECTION PUMP MAKE: \_\_\_\_\_ MODEL: \_\_\_\_\_

ALTERNATOR MAKE: \_\_\_\_\_ PART #: \_\_\_\_\_

STARTER MAKE: \_\_\_\_\_ PART #: \_\_\_\_\_

TURBO CHARGER MAKE: \_\_\_\_\_ PART #: \_\_\_\_\_

TRANS. MAKE: \_\_\_\_\_ MODEL: \_\_\_\_\_ AUTO/MANUAL: \_\_\_\_\_

HYDRAULIC PUMP MAKE: \_\_\_\_\_ MODEL: \_\_\_\_\_

FILTERS	MAKE	PART NO.	LUBRICANT	MANUFACTURER TYPE
OIL	_____	_____	ENGINE	_____
AIR INNER	_____	_____	TRANSMISSION	_____
AIR OUTER	_____	_____	POWER STEERING	_____
FUEL PRIMARY	_____	_____	HYDRAULIC	_____
FUEL SECONDARY	_____	_____	DIFFERENTIALS	_____
COOLANT	_____	_____	BRAKE FLUID	_____
HYDRAULIC	_____	_____	COOLANT	_____
OTHER	_____	_____	OTHER	_____

X6.3 TRAINING:

Will training seminar be conducted on Preventive Maintenance, Operator and Mechanic Training  YES  NO

Will you conduct training with each purchase order against this open end contract?  YES  NO

Will training be conducted within 2 working days from the delivery of the pilot unit on the individual purchase order?  YES  NO

If NO, explain time frame \_\_\_\_\_

Will an Operator's Manual be furnished directly to Training Academy prior to the delivery of the pilot?  YES  NO

X6.4 If you are the successful vendor, will you furnish all training aids, i.e., videos, projectors, required in conducting the training?  YES  NO

X6.4.1 Will all manuals, booklets, etc. explaining preventive maintenance, operator procedures, and service schedule be delivered with each unit?  YES  NO  
If NO, explain \_\_\_\_\_

X6.5 WARRANTY AND SERVICE POLICY

Will the warranty and service you provide comply with all areas as stated in Section 6.5 of specifications  YES  NO

Is warranty literature attached?  YES  NO

Is a minimum two (2) year bumper to bumper basic parts and labor warranty excluding abuse and normal wear items included?  YES  NO

Describe:  
Two years parts and labor bumper to bumper



## X6.6 EVALUATION COMMITTEE REQUIREMENTS

Is all component specifications, product literature, component models provided for Evaluation Committee bid determination?  YES  NO

**X6.7 Will all parts, equipment, accessories, material, design and performance characteristics not specified herein, but which are necessary to provide a complete unit, be furnished with the unit and conform in strength, quality of material, and quality of workmanship to those which are advertised and provided to the market in general by the unit industry?**

YES  NO

**X6.7.1 Are all parts and accessories adequate and regularly supplied as standard to be included except those which may be duplications of specifications herein, and except these by specification are not to be furnished?**

YES  NO

**X6.7.2 Are all standard safety features that are required by Federal and State statutes of law included?**

YES  NO

## X7.0 SPECIFICATIONS OF THE QUOTED UNIT:

The bidder should complete the following schedule in order for the Division to compare the actual bid unit to the specifications. Should the bidder except a requirement, then such exception may be only on the basis that such feature is not offered by the manufacturer. The Division will have the sole discretion as to whether the bidder's substitution meets the requirements of the specification.

Manufacturer: Layton Model: F525

X7.0 Paver:

**X7.1 Is paver capable of laying asphalt from a minimum depth, (determined by the size aggregate in mix) to a maximum thickness of approximately six (6) inches?**  YES  NO

**X7.2 Is paver capable of paving from eight (8) to (12) foot width and is paver capable of varying width while paving?**  YES  NO

**X7.3 Is unit designed to be transported on the rear of a tandem or single axle dump truck?**  YES  NO

X7.4 Hopper:

X7.4.1 Specify paver hopper storage capacity 3 tons

X7.4.2 Does hopper have a shut off safe gate capable of closing with a full hopper?  YES  NO

X7.4.3 Is hopper equipped with adjustable side plates for deflecting material into hopper?  YES  NO



- X7.4.4 Is unit equipped with a truck tailgate stop?  YES  NO
- X7.5 Under Carriage:
- X7.5.1 The paver is supported during paving operations by 8 tires and wheels by **eight (8) tires and wheels?**  YES  NO
- X7.5.2 Are tires and wheels located to give full support during paving operations and keep stable during hook-up and disconnect from truck?  YES  NO
- X7.6 Screed:
- X7.6.1 Is screed equipped with a bolt-on, reversible and replaceable screed plate?**  YES  NO
- X7.6.2 Screed plate: 3/16 inches thick
- X7.6.3 Is screed plate heat-treated and of abrasion-resistant steel?  YES  NO
- X7.6.4 Is screed capable of a crown or inverted crown of up to three (3) inches?  YES  NO
- X7.6.5 Is paving depth controlled manually on each side of screed?  YES  NO
- X7.6.6 Are screed strike-off extensions for paving 12 inches left and 12 inches right provided?  YES  NO
- X7.6.7 Is screed heater provided on paver fueled by propane only**  YES  NO
- X7.6.8 Is screed heater connected to a five (5) gallon propane tank?  YES  NO
- X7.6.9 Is propane tank equipped with an adjustable pressure regulator and pressure gauge?  YES  NO
- X7.7 Hydraulic System:
- X7.7.1 Is paver equipped with an electric powered hydraulic system?  YES  NO
- X7.7.2 Is central hydraulic hand pump provided for back-up use?  YES  NO
- X7.7.3 Electric power source: 12 Volts with 90 amp battery?
- X7.7.4 Are hydraulic controls mounted on left side of paver for operator to maintain eye and hand signal contact with driver?  YES  NO
- X7.7.5 Is unit equipped with independently controlled augers?  YES  NO
- X7.7.6 Are augers mounted low in hopper for right/left side distribution of material?  YES  NO

X7.8 Does unit conform to specified advertising guidelines?  YES  NO

X7.9 Paint:

Describe proposed method of painting the unit: Steel is cleaned, degreased,  
primed and painted with two coats of Layton green finish  
coats (lead free)

X7.9.1 Is unit painted manufacturer's standard color?  YES  NO

X7.9.2 Are areas a distinct color for safety reasons painted as they normally would be?  YES  NO

X7.10 Does proposed unit meet or exceed the "OSHA OF 1970" and/or subsequent changes?  
 YES  NO

709EC003  
PRE BID ADDENDUM #3

HYDRAULIC CONTROLLED, TOWED TYPE, BITUMINOUS PAVER  
(LAYTON BOX)

CHANGES TO BIDDER'S EVALUATION REPORT

ADD EXHIBIT 4 TO DEPARTMENT OF ADMINISTRATION FRONT FORMAT:

X4.2 DELIVERY:  
3<sup>RD</sup> PARAGRAPH – NO CHANGE REQUIRED

X4.2.1 Delivery date of completed representative unit: 30 Calendar Days After  
Receipt of Purchase Agreement

ADD:

X7.4.5 Is hopper notched in center to accommodate the trucks pintle hitch  
 x  YES   NO

\*\*\*CHANGE NUMBERING SYSTEM OF X7.7 THROUGH AND INCLUDING X7.10

ADD:

X7.7 Hitch Arms:

X7.7.1 Are hitch arms heavy duty alloy steel  x  YES   NO

X7.7.2 Does unit have tapered roller bearings in rim rolls   YES  x  NO

X7.7.3 Does unit have roller thrust bearings in side rolls  x  YES   NO

X7.7.4 Are hitch arms adjustable in 3 inch increments up to 15 inches  
 x  YES   NO

## X7.8 Hydraulic System:

FROM:

X7.7.1 Is paver equipped with an electric powered hydraulic system \_\_\_\_\_ YES \_\_\_\_\_ NO

CHANGE TO READ:

X7.8.1 Is paver equipped with two (2) propane fueled engines on each side of unit for better weight distribution   x   YES \_\_\_\_\_ NO

**Does each engine power all low pressure hydraulic functions for its respective Side**   x   YES \_\_\_\_\_ NO

FROM:

X7.7.2 Is central hydraulic hand pump provided for back up use \_\_\_\_\_ YES \_\_\_\_\_ NO

TO:

X7.8.2 Is central hydraulic hand pump provided for back up use   x   YES \_\_\_\_\_ NO

FROM:

X7.7.3 Electric power source: \_\_\_\_\_ volts with \_\_\_\_\_ amp battery

CHANGE TO READ:

X7.8.3 **Are engines equipped with electric starter and alternator**   x   YES \_\_\_\_\_ NO

FROM:

X7.7.4 Are hydraulic controls mounted on left side of paver for operator to maintain eye and hand signal contact with driver \_\_\_\_\_ YES \_\_\_\_\_ NO

TO:

X7.8.4 Are hydraulic controls mounted on left side of paver for operator to maintain eye and hand signal contact with driver   x   YES \_\_\_\_\_ NO

FROM:

X7.7.5 Is unit equipped with independently controlled augers \_\_\_\_\_ YES \_\_\_\_\_ NO

TO:

X7.8.5 Is unit equipped with independently controlled augers   x   YES \_\_\_\_\_ NO



WEST VIRGINIA TRACTOR COMPANY

709EC003 Exceptions to Specifications

- 7.7.2 The standard hitch arms have tapered roller bearings. However, the optional adjustable hitch arms, which are specified, have bushings.

# Warranty

CUSTOMER TO RETAIN THIS CARD  
MACHINE MODEL NO.  
SERIAL NO.

Standard warranty extended to  
two years parts and labor

**WARRANTY:** LAYTON MANUFACTURING CO., 4725 Turner Road, Salem, Oregon 97301, hereby warrants to the purchaser of its products from its manufacturing facility or any authorized LAYTON MANUFACTURING CO. DISTRIBUTOR or REPRESENTATIVE for a period of twelve (12) months from the date of purchase, that the product shall be free from defects in material and workmanship.

**UNAUTHORIZED REPAIR OR ABUSE:** The Warranty included herein shall not apply to any product that shall have been serviced or repaired by other than the Manufacturer or its authorized service or repair facility, or authorized DISTRIBUTOR, or altered in any way that would, in the Manufacturer's judgment, affect its operation or reliability, or the product or any component thereof shall have been subjected to misuse by negligence or accident or failure to adhere to the written instructions prescribed in the Operation and Service Manuals provided by the Manufacturer.

**EXPRESS WARRANTY IN LIEU OF ALL OTHER WARRANTIES:** This Warranty is express and in lieu of any and all other warranties relating to the product, express or implied, including but not limited to, any warranty of merchantability and any other statements made which might imply liability on the part of the Manufacturer. It is expressly understood that any such statements were not intended to, and did not, form a part of the purchase agreement and that said statements were merely made in the course of negotiations of the parties. There are NO warranties which extend beyond the face hereof.

**MANUFACTURER TO REPAIR OR REPLACE:** LAYTON MANUFACTURING CO. will, at its option, without charge to the original purchaser, supply materials and labor and replace or repair any part or parts found upon examination by any authorized LAYTON MANUFACTURING CO. REPRESENTATIVE or at the LAYTON MANUFACTURING CO. facility in Salem, Oregon to be defective in material or workmanship, or both, within twelve (12) months from the date of original purchase from an authorized LAYTON MANUFACTURING CO. DISTRIBUTOR or REPRESENTATIVE.

**PLACE OF REPAIR:** LAYTON MANUFACTURING CO. authorizes its DISTRIBUTOR to perform the warranty service work at the original purchaser's site or at such other location as may be convenient.

**RISK OF LOSS AND SHIPPING COST:** Any transportation charges for, or the risk of damage or loss incurred in connection with the transportation of the product or component parts submitted to LAYTON MANUFACTURING CO. for inspection and replacement or repair, or both, under this Warranty, shall be borne by the purchaser.

**NON-LIABILITY OF LAYTON FOR LOSS OF USE:** LAYTON MANUFACTURING CO. shall not be liable for loss of profit or any other damages or claims for damages arising out of, or in connection with, delays or interruptions of the use of the product by purchaser whether such shall occur by reason of defective material or workmanship or both, or any delays or interruptions in the use of the product occurring by reason of the shipment or transportation to the LAYTON MANUFACTURING CO. facility or its DISTRIBUTOR.

**NON-LIABILITY OF LAYTON FOR INJURY OR DAMAGE:** LAYTON MANUFACTURING CO. shall not, under any circumstances, be held liable or responsible for injuries or damages to persons or property arising out of, or in connection with, the willful or negligent misuse, including operation beyond rated capacity or other use even if in accordance with Manufacturer's printed instructions, or any injuries or damages to persons or property arising out of, or in connection with, the use or operation of any of its products.

**"AS IS" SALE OF USED EQUIPMENT:** The Warranty included herein shall not apply to used equipment or products, and the purchaser thereof waives any warranties, express or implied, by law and such equipment is sold "as is" with all defects unless such a warranty is made in writing and in a form and manner authorized by the Manufacturer.

**DESIGN CHANGES:** LAYTON MANUFACTURING CO. reserves the right to make changes in design, or to make additions to, or improve its products without imposing any obligation upon itself to install them on its products previously sold.



LAYTON MANUFACTURING CO 4725 Turner Rd., Salem, OR. 97301

WEST VIRGINIA TRACTOR COMPANY

COMPLIANCE WITH WEST VIRGINIA PURCHASING RULES

As required by law and West Virginia Department of Administration, Purchasing Division Legislative Rule 148 CSR 1, West Virginia Tractor Company is licensed and in good standing with any and all state and local laws and requirements, including the West Virginia Secretary of State's office, the West Virginia Tax Department, the West Virginia Insurance Commission, or any other state agencies or political subdivisions, including the West Virginia Division of Motor Vehicles as a trailer dealer (DTR-1594) and as a new vehicle dealer (D-43).

West Virginia Code 5A-3-10a. Prohibition for awarding contracts to vendors which owe a debt to the state or its political subdivisions, stipulates that this applies to contracts or renewal of contracts to be awarded by the state or any of its political subdivisions, which includes counties and municipalities.

West Virginia Tractor Company does not discriminate against any employee or applicant for employment because of race, religion, color, sex, handicap, or national origin.



STATE OF WEST VIRGINIA  
Purchasing Division**PURCHASING AFFIDAVIT****VENDOR OWING A DEBT TO THE STATE:**

*West Virginia Code* §5A-3-10a provides that: No contract or renewal of any contract may be awarded by the state or any of its political subdivisions to any vendor or prospective vendor when the vendor or prospective vendor or a related party to the vendor or prospective vendor is a debtor and the debt owed is an amount greater than one thousand dollars in the aggregate.

**PUBLIC IMPROVEMENT CONTRACTS & DRUG-FREE WORKPLACE ACT:**

*West Virginia Code* §21-1D-5 provides that: Any solicitation for a public improvement construction contract shall require each vendor that submits a bid for the work to submit at the same time an affidavit that the vendor has a written plan for a drug-free workplace policy in compliance with Article 1D, Chapter 21 of the West Virginia Code. A public improvement construction contract may not be awarded to a vendor who does not have a written plan for a drug-free workplace policy in compliance with Article 1D, Chapter 21 of the West Virginia Code and who has not submitted that plan to the appropriate contracting authority in timely fashion. For a vendor who is a subcontractor, compliance with Section 5, Article 1D, Chapter 21 of the West Virginia Code may take place before their work on the public improvement is begun.

**ANTITRUST:**

In submitting a bid to any agency for the state of West Virginia, the bidder offers and agrees that if the bid is accepted the bidder will convey, sell, assign or transfer to the state of West Virginia all rights, title and interest in and to all causes of action it may now or hereafter acquire under the antitrust laws of the United States and the state of West Virginia for price fixing and/or unreasonable restraints of trade relating to the particular commodities or services purchased or acquired by the state of West Virginia. Such assignment shall be made and become effective at the time the purchasing agency tenders the initial payment to the bidder.

I certify that this bid is made without prior understanding, agreement, or connection with any corporation, firm, limited liability company, partnership or person or entity submitting a bid for the same materials, supplies, equipment or services and is in all respects fair and without collusion or fraud. I further certify that I am authorized to sign the certification on behalf of the bidder or this bid.

**LICENSING:**

Vendors must be licensed and in good standing in accordance with any and all state and local laws and requirements by any state or local agency of West Virginia, including, but not limited to, the West Virginia Secretary of State's Office, the West Virginia Tax Department, West Virginia Insurance Commission, or any other state agencies or political subdivision. Furthermore, the vendor must provide all necessary releases to obtain information to enable the Director or spending unit to verify that the vendor is licensed and in good standing with the above entities.

**CONFIDENTIALITY:**

The vendor agrees that he or she will not disclose to anyone, directly or indirectly, any such personally identifiable information or other confidential information gained from the agency, unless the individual who is the subject of the information consents to the disclosure in writing or the disclosure is made pursuant to the agency's policies, procedures and rules. Vendors should visit [www.state.wv.us/admin/purchase/privacy](http://www.state.wv.us/admin/purchase/privacy) for the Notice of Agency Confidentiality Policies.

Under penalty of law for false swearing (West Virginia Code §61-5-3), it is hereby certified that the vendor acknowledges the information in this said affidavit and is in compliance with the requirements as stated.

Vendor's Name: West Virginia Tractor Company  
 Authorized Signature:  Date: 9/22/08



State of West Virginia  
 Department of Administration  
 Purchasing Division  
 2019 Washington Street East  
 Post Office Box 50130  
 Charleston, WV 25305-0130

# Request for Quotation

RFO NUMBER  
**709EC003**

PAGE  
**1**

ADDRESS CORRESPONDENCE TO ATTENTION OF  
**MICHAEL AUSTIN**  
**304-558-2402**

PROPERTY

\*709051756      304-346-5301  
**WV TRACTOR COMPANY**  
**PO BOX 473**  
  
**CHARLESTON WV 25322**

SHIP TO

**DIVISION OF HIGHWAYS**  
**EQUIPMENT DIVISION**  
**ROUTE 33**  
**BRUSHY FORK ROAD**  
**BUCKHANNON, WV**  
**26201**      **304-472-1750**

DATE PRINTED	TERMS OF SALE	SHIP VIA	F.O.B.	FREIGHT TERMS
09/15/2008	Net 30 Days	Truck	Buckhannon	Prepaid

BID OPENING DATE: **09/24/2008**      **BID OPENING TIME 01:30PM**

LINE	QUANTITY	UOP	CAT NO	ITEM NUMBER	UNIT PRICE	AMOUNT
<b>ADDENDUM NO. 1</b>						
<b>BID OPENING DATE AND TIME CHANGED</b>						
<b>FROM: 09/17/08 AT 1:30 P.M.</b>						
<b>TO: 09/24/09 AT 1:30 P.M.</b>						
<b>NO OTHER CHANGES</b>						
0001	1	EA		755-35 Layton F525		
<b>HYDRAULIC CONTROLLED, TOWED TYPE, BITUMINOUS PAVER</b>						
<b>***** THIS IS THE END OF RFQ 709EC003 ***** TOTAL:</b>						

SEE REVERSE SIDE FOR TERMS AND CONDITIONS

SIGNATURE <i>Gayle Gray</i>	TELEPHONE 346-5301	DATE 9-22-08
TITLE President	FEIN 550621655	ADDRESS CHANGES TO BE NOTED ABOVE

WHEN RESPONDING TO RFQ, INSERT NAME AND ADDRESS IN SPACE ABOVE LABELED 'VENDOR'



State of West Virginia  
 Department of Administration  
 Purchasing Division  
 2019 Washington Street East  
 Post Office Box 50130  
 Charleston, WV 25305-0130

# Request for Quotation

RFQ NUMBER  
 709EC003

PAGE  
 1

ADDRESS CORRESPONDENCE TO ATTENTION OF  
 MICHAEL AUSTIN  
 304-558-2402

\*709051756 304-346-5301  
 WV TRACTOR COMPANY  
 PO BOX 473  
 CHARLESTON WV 25322

DIVISION OF HIGHWAYS  
 EQUIPMENT DIVISION  
 ROUTE 33  
 BRUSHY FORK ROAD  
 BUCKHANNON, WV  
 26201 304-472-1750

DATE PRINTED	TERMS OF SALE	SHIP VIA	F.O.B	FREIGHT TERMS
09/22/2008	Net 30 Days	Truck	Buckhannon	Prepaid

BID OPENING DATE: 10/01/2008 BID OPENING TIME 01:30PM

LINE	QUANTITY	UOP	CAT NO	ITEM NUMBER	UNIT PRICE	AMOUNT
ADDENDUM NO. 2						
BID OPENING DATE AND TIME CHANGED						
FROM: 09/24/08 AT 1:30 P.M.						
TO: 10/01/08 AT 1:30 P.M.						
NO OTHER CHANGES						
0001	1	EA		755-35 LAYTON F525		
HYDRAULIC CONTROLLED, TOWED TYPE, BITUMINOUS PAVER						
***** THIS IS THE END OF RFQ 709EC003 ***** TOTAL:						

SEE REVERSE SIDE FOR TERMS AND CONDITIONS

SIGNATURE <i>Paul W. Gray</i>	TELEPHONE 346-9372	DATE 9-26-08
TITLE President	FEIN 550621655	ADDRESS CHANGES TO BE NOTED ABOVE

WHEN RESPONDING TO RFQ, INSERT NAME AND ADDRESS IN SPACE ABOVE LABELED 'VENDOR'

**GENERAL TERMS & CONDITIONS  
REQUEST FOR QUOTATION (RFQ) AND REQUEST FOR PROPOSAL (RFP)**

1. Awards will be made in the best interest of the State of West Virginia.
2. The State may accept or reject in part, or in whole, any bid.
3. All quotations are governed by the *West Virginia Code* and the *Legislative Rules* of the Purchasing Division.
4. Prior to any award, the apparent successful vendor must be properly registered with the Purchasing Division and have paid the required \$125 fee.
5. All services performed or goods delivered under State Purchase Order/Contracts are to be continued for the term of the Purchase Order/Contracts, contingent upon funds being appropriated by the Legislature or otherwise being made available. In the event funds are not appropriated or otherwise available for these services or goods, this Purchase Order/Contract becomes void and of no effect after June 30.
6. Payment may only be made after the delivery and acceptance of goods or services.
7. Interest may be paid for late payment in accordance with the *West Virginia Code*.
8. Vendor preference will be granted upon written request in accordance with the *West Virginia Code*.
9. The State of West Virginia is exempt from federal and state taxes and will not pay or reimburse such taxes.
10. The Director of Purchasing may cancel any Purchase Order/Contract upon 30 days written notice to the seller.
11. The laws of the State of West Virginia and the *Legislative Rules* of the Purchasing Division shall govern all rights and duties under the Contract, including without limitation the validity of this Purchase Order/Contract.
12. Any reference to automatic renewal is hereby deleted. The Contract may be renewed only upon mutual written agreement of the parties.
13. **BANKRUPTCY:** In the event the vendor/contractor files for bankruptcy protection, this Contract may be deemed null and void, and terminated without further order.
14. **HIPAA BUSINESS ASSOCIATE ADDENDUM:** The West Virginia State Government HIPAA Business Associate Addendum (BAA), approved by the Attorney General, and available online at the Purchasing Division's web site (<http://www.state.wv.us/admin/purchase/vrc/hipaa.htm>) is hereby made part of the agreement. Provided that, the Agency meets the definition of a Cover Entity (45 CFR §160.103) and will be disclosing Protected Health Information (45 CFR §160.103) to the vendor.
15. **WEST VIRGINIA ALCOHOL & DRUG-FREE WORKPLACE ACT:** If this Contract constitutes a public improvement construction contract as set forth in Article 1D, Chapter 21 of the West Virginia Code ("The West Virginia Alcohol and Drug-Free Workplace Act"), then the following language shall hereby become part of this Contract: "The contractor and its subcontractors shall implement and maintain a written drug-free workplace policy in compliance with the West Virginia Alcohol and Drug-Free Workplace Act, as set forth in Article 1D, Chapter 21 of the West Virginia Code. The contractor and its subcontractors shall provide a sworn statement in writing, under the penalties of perjury, that they maintain a valid drug-free work place policy in compliance with the West Virginia and Drug-Free Workplace Act. It is understood and agreed that this Contract shall be cancelled by the awarding authority if the Contractor: 1) Fails to implement its drug-free workplace policy; 2) Fails to provide information regarding implementation of the contractor's drug-free workplace policy at the request of the public authority; or 3) Provides to the public authority false information regarding the contractor's drug-free workplace policy."

---

**INSTRUCTIONS TO BIDDERS**

1. Use the quotation forms provided by the Purchasing Division.
2. **SPECIFICATIONS:** Items offered must be in compliance with the specifications. Any deviation from the specifications must be clearly indicated by the bidder. Alternates offered by the bidder as **EQUAL** to the specifications must be clearly defined. A bidder offering an alternate should attach complete specifications and literature to the bid. The Purchasing Division may waive minor deviations to specifications.
3. Complete all sections of the quotation form.
4. Unit prices shall prevail in case of discrepancy.
5. All quotations are considered F.O.B. destination unless alternate shipping terms are clearly identified in the quotation.
6. **BID SUBMISSION:** All quotations must be delivered by the bidder to the office listed below prior to the date and time of the bid opening. Failure of the bidder to deliver the quotations on time will result in bid disqualifications: Department of Administration, Purchasing Division, 2019 Washington Street East, P.O. Box 50130, Charleston, WV 25305-0130



State of West Virginia  
 Department of Administration  
 Purchasing Division  
 2019 Washington Street East  
 Post Office Box 50130  
 Charleston, WV 25305-0130

# Request for Quotation

RFQ NUMBER  
 709EC003

PAGE  
 1

ADDRESS CORRESPONDENCE TO ATTENTION OF:  
 MICHAEL AUSTIN  
 304-558-2402

VENDOR

\*709051756 304-346-5301  
 WV TRACTOR COMPANY  
 PO BOX 473  
 CHARLESTON WV 25322

SHIP TO

DIVISION OF HIGHWAYS  
 EQUIPMENT DIVISION  
 ROUTE 33  
 BRUSHY FORK ROAD  
 BUCKHANNON, WV  
 26201 304-472-1750

DATE PRINTED	TERMS OF SALE	SHIP VIA	FOB	FREIGHT TERMS
09/29/2008	Net 30 Days	Truck	Buckhannon	Prepaid

BID OPENING DATE: 10/08/2008 BID OPENING TIME 01:30PM

LINE	QUANTITY	UOP	CAT NO	ITEM NUMBER	UNIT PRICE	AMOUNT
ADDENDUM NO. 3						
CHANGES TO THE SPECIFICATIONS ATTACHED.						
BID OPENING DATE AND TIME CHANGED						
FROM: 10/01/08 AT 1:30 P.M.						
TO: 10/08/08 AT 1:30 P.M.						
NO OTHER CHANGES.						
0001	1	EA		755-35 LAYTON F525		
HYDRAULIC CONTROLLED, TOWED TYPE, BITUMINOUS PAVER						
***** THIS IS THE END OF RFQ 709EC003 ***** TOTAL:						

SEE REVERSE SIDE FOR TERMS AND CONDITIONS

SIGNATURE: *Paul Gray* TELEPHONE: 346-5301 DATE: 10-3-08

TITLE: President FEIN: 550621055

ADDRESS CHANGES TO BE NOTED ABOVE

WHEN RESPONDING TO RFQ, INSERT NAME AND ADDRESS IN SPACE ABOVE LABELED 'VENDOR'



*Asphalt paving  
Equipment specialists!*

# MODEL F-525 PAVER

It's been proven . . . There's No Finer Tow-Pavers Manufactured than LAYTON! Designed for Performance, Dependability, and Long Life —

*A Layton Tradition!*

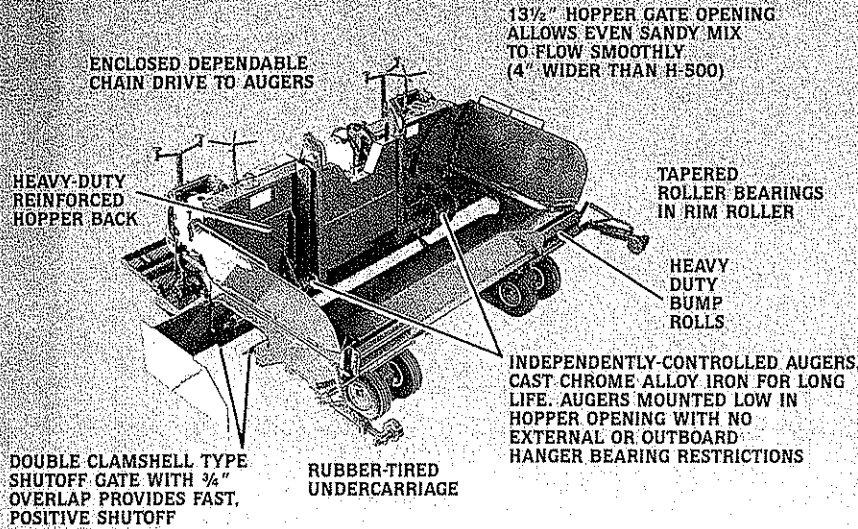

A "Tow Paver" designed for the user who regularly needs to pave wider than 10 feet without extra shoveling. The independent, dual-controlled augers move enough material to allow paving 12 feet wide, 2 inches deep at the rate of 100 feet per minute with 300° hot mix. The paver is pictured below with an *optional* screed heater and electric-hydraulic controls.

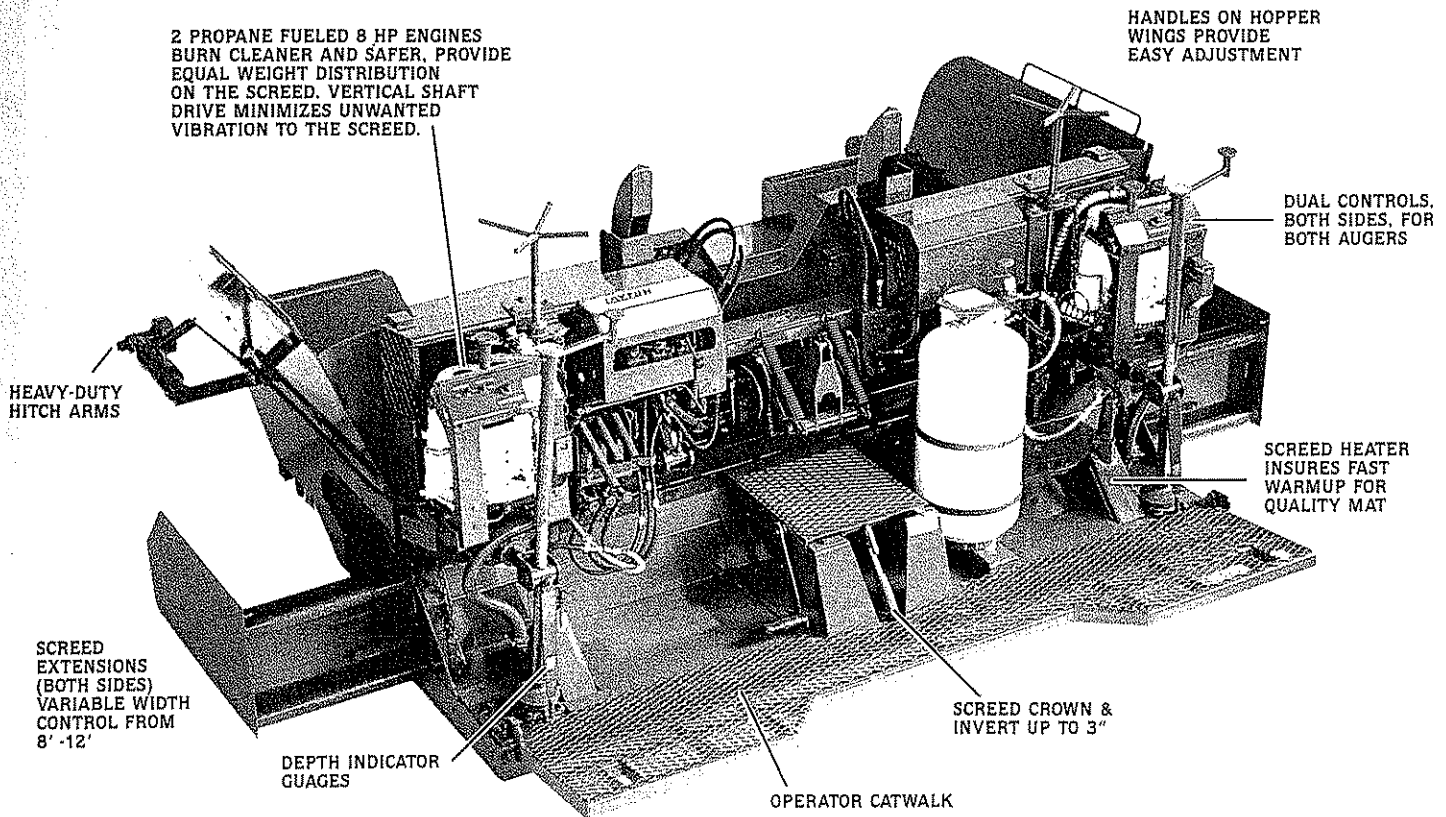



MODEL F-525

# PAVER SPECIFICATIONS

## MISCELLANEOUS SPECIFICATIONS

Height ..... 5' 4"  
 Length ..... 6' 5"  
 Width ..... 8'  
 Spread depth ..... 0"-6" or 4"-10"  
 Screed width ..... 8' -12'  
 Operation speed... 12' wide, 2" deep, 100' per minute  
 Weight (Basic Machine) ..... 3600 lbs. (approx.)

## ENGINES

2 heavy-duty vertical shaft Tecumseh ..... 8 h.p.  
 Electric starter ..... standard  
 Alternator (7 AMP) ..... standard  
 Hand recoil starter ..... standard  
 Aluminum block ..... standard  
 w/ Cast iron cylinder liner

## FUEL SYSTEM

Propane ..... 10 gal. tank supplies  
 a common fuel for both engines and  
 "optional" screed heater

## HITCH ARMS

Heavy-duty alloy steel ..... standard  
 Tapered roller bearings in rim rolls ..... standard  
 Roller thrust bearings in side rolls ..... standard

## CONTROLS

Hitch arms ..... hand pump or electric hydraulic unit  
 Shutoff gate ..... hand pump or electric hydraulic unit  
 Screed hoist ..... hand pump or electric hydraulic unit  
 Screed extension ..... manual\*  
 Depth controls ..... manual  
 Augers ..... dual control, toggle switches

## AUGERS

Material ..... cast chrome alloy iron  
 Auger flights ..... 3/8" thick, 20" long, 9" diameter  
 Double #50 roller chain drive ..... standard  
 Shaft ..... 2 3/8" diameter, A140 alloy steel  
 Speed ..... 100 r.p.m.  
 Installation ..... low in hopper w/no external hanger bearings

## UNDERCARRIAGE

Rubber tires (8 total) ..... two sets of dual tandem pneumatic  
 Size ..... 5.30 x 6 six-ply mounted in line  
 Each set walking beam mounted ..... standard

## HOPPER

Capacity ..... 3 tons  
 Shutoff ..... coordinated double clamshell type  
 shutoff gate with 3/4" overlap  
 Hopper opening ..... 13 1/2"

## SCREED PLATE

Bolt-on type reversible ..... standard  
 Hardness ..... 360-400 brinell  
 Thickness ..... 3/16"  
 Heat treated, abrasion resistant ..... standard  
 Tensile strength ..... 190,000 p.s.i.

## SCREED CROWN & INVERT

Maximum crown or invert ..... 3"  
 Ratchet operated ..... both trailing and leading edge  
 controlled simultaneously  
 Mounted on universal joints ..... standard

## SCREED HOIST

Two cylinders with single arm ..... hydraulically operated

## HYDRAULIC SYSTEM

Auger ..... engine driven hydraulic pumps,  
 one engine driven pump for each side  
 Hitch arms, shutoff gate, screed hoist ..... manual  
 hand pump or optional electric hydraulic unit

## OPTIONAL EQUIPMENT

### Electric Hydraulic System

D.C. motor, battery powered, charged by engine  
 alternator, hand pump backup system

### Screed Heater

2 burner externally mounted  
 Heat conductor

### Ditch Plates

Attach to screed extension  
 Adjustable from 2' to 9' wide

### \*Hydraulic Powered Extensions (factory option only)

Extensions powered by engine driven hydraulic

### Joint Matching Extensions

Two plates ..... each 1' or 2' wide  
 Attach to end of screed  
 Each plate with separate heat

### Adjustable Hitch Arms

Adjustable in 3-inch increments up to 15"

*We reserve the right to revise or change specifications without obligation or notice.*

**WARRANTY — ONE YEAR PARTS & LABOR**