



State of West Virginia
 Department of Administration
 Purchasing Division
 2019 Washington Street East
 Post Office Box 50130
 Charleston, WV 25305-0130

Request for Quotation

RFQ NUMBER
709C0009

PAGE
1

ADDRESS CORRESPONDENCE TO ATTENTION OF
MICHAEL AUSTIN 304-558-2402

VENDOR

*709051756 304-346-5301
 WV TRACTOR COMPANY
 PO BOX 473
 CHARLESTON WV 25322

SHIP TO

DIVISION OF HIGHWAYS
 EQUIPMENT DIVISION
 ROUTE 33
 BRUSHY FORK ROAD
 BUCKHANNON, WV
 26201 304-472-1750

DATE PRINTED	TERMS OF SALE	SHIP VIA	FOB	FREIGHT TERMS
01/14/2009	Net 30 Days	Truck	Buckhannon	Prepaid

BID OPENING DATE: 01/28/2009 BID OPENING TIME 01:30PM

LINE	QUANTITY	UOP	CAT NO	ITEM NUMBER	UNIT PRICE	AMOUNT
0001	1	EA		060-74 POWERTILT PT-7 REPLACEMENT PARTS FOR LOADER, BACKHOE		
OPEN END CONTRACT						
TO PROVIDE TEREX MODEL TX760B LOADER, BACKHOE BOOM SWIVEL PARTS OR EQUAL WHICH MAY BE REQUIRED BY THE WEST VIRGINIA DIVISION OF HIGHWAYS PER THE ATTACHED SPECIFICATIONS.						
THIS CONTRACT EXCLUDES THE PURCHASE OF WHOLE UNIT COMPONENTS WHICH MAY BE LISTED WITHIN THE MANUFACTURERS PRICE LIST.						
THE MODEL/BRAND/SPECIFICATIONS NAMED HEREIN ESTABLISH THE ACCEPTABLE LEVEL OF QUALITY ONLY AND ARE NOT INTENDED TO REFLECT A PREFERENCE OR FAVOR ANY PARTICULAR BRAND OR VENDOR. VENDORS WHO ARE BIDDING ALTERNATES SHOULD SO STATE AND INCLUDE PERTINENT LITERATURE AND SPECIFICATIONS. FAILURE TO PROVIDE INFORMATION FOR ANY ALTERNATES MAY BE GROUNDS FOR REJECTION OF THE BID. THE STATE RESERVES THE RIGHT TO WAIVE MINOR IRREGULARITIES IN BIDS OR SPECIFICATIONS IN ACCORDANCE WITH SECTION 148-1-4(F) OF THE WEST VIRGINIA LEGISLATIVE RULES AND REGULATIONS.						
EXHIBIT 3						
LIFE OF CONTRACT: THIS CONTRACT BECOMES EFFECTIVE ON AND EXTENDS FOR A PERIOD OF ONE (1						

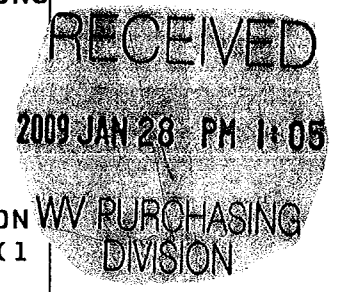

SEE REVERSE SIDE FOR TERMS AND CONDITIONS			
SIGNATURE	TELEPHONE	DATE	
<i>Ray Gray</i>	346-5301	1-27-09	
TITLE	FEIN	ADDRESS CHANGES TO BE NOTED ABOVE	
President	550621655		

WHEN RESPONDING TO RFQ, INSERT NAME AND ADDRESS IN SPACE ABOVE LABELED 'VENDOR'

GENERAL TERMS & CONDITIONS
REQUEST FOR QUOTATION (RFQ) AND REQUEST FOR PROPOSAL (RFP)

1. Awards will be made in the best interest of the State of West Virginia.
2. The State may accept or reject in part, or in whole, any bid.
3. All quotations are governed by the *West Virginia Code* and the *Legislative Rules* of the Purchasing Division.
4. Prior to any award, the apparent successful vendor must be properly registered with the Purchasing Division and have paid the required \$125 fee.
5. All services performed or goods delivered under State Purchase Order/Contracts are to be continued for the term of the Purchase Order/Contracts, contingent upon funds being appropriated by the Legislature or otherwise being made available. In the event funds are not appropriated or otherwise available for these services or goods, this Purchase Order/Contract becomes void and of no effect after June 30.
6. Payment may only be made after the delivery and acceptance of goods or services.
7. Interest may be paid for late payment in accordance with the *West Virginia Code*.
8. Vendor preference will be granted upon written request in accordance with the *West Virginia Code*.
9. The State of West Virginia is exempt from federal and state taxes and will not pay or reimburse such taxes.
10. The Director of Purchasing may cancel any Purchase Order/Contract upon 30 days written notice to the seller.
11. The laws of the State of West Virginia and the *Legislative Rules* of the Purchasing Division shall govern all rights and duties under the Contract, including without limitation the validity of this Purchase Order/Contract.
12. Any reference to automatic renewal is hereby deleted. The Contract may be renewed only upon mutual written agreement of the parties.
13. **BANKRUPTCY:** In the event the vendor/contractor files for bankruptcy protection, this Contract may be deemed null and void, and terminated without further order.
14. **HIPAA BUSINESS ASSOCIATE ADDENDUM:** The West Virginia State Government HIPAA Business Associate Addendum (BAA), approved by the Attorney General, and available online at the Purchasing Division's web site (<http://www.state.wv.us/admin/purchase/vrc/hipaa.htm>) is hereby made part of the agreement. Provided that, the Agency meets the definition of a Cover Entity (45 CFR §160.103) and will be disclosing Protected Health Information (45 CFR §160.103) to the vendor.
15. **WEST VIRGINIA ALCOHOL & DRUG-FREE WORKPLACE ACT:** If this Contract constitutes a public improvement construction contract as set forth in Article 1D, Chapter 21 of the West Virginia Code ("The West Virginia Alcohol and Drug-Free Workplace Act"), then the following language shall hereby become part of this Contract: "The contractor and its subcontractors shall implement and maintain a written drug-free workplace policy in compliance with the West Virginia Alcohol and Drug-Free Workplace Act, as set forth in Article 1D, Chapter 21 of the West Virginia Code. The contractor and its subcontractors shall provide a sworn statement in writing, under the penalties of perjury, that they maintain a valid drug-free work place policy in compliance with the West Virginia and Drug-Free Workplace Act. It is understood and agreed that this Contract shall be cancelled by the awarding authority if the Contractor: 1) Fails to implement its drug-free workplace policy; 2) Fails to provide information regarding implementation of the contractor's drug-free workplace policy at the request of the public authority; or 3) Provides to the public authority false information regarding the contractor's drug-free workplace policy."

INSTRUCTIONS TO BIDDERS

1. Use the quotation forms provided by the Purchasing Division.
2. **SPECIFICATIONS:** Items offered must be in compliance with the specifications. Any deviation from the specifications must be clearly indicated by the bidder. Alternates offered by the bidder as **EQUAL** to the specifications must be clearly defined. A bidder offering an alternate should attach complete specifications and literature to the bid. The Purchasing Division may waive minor deviations to specifications.
3. Complete all sections of the quotation form.
4. Unit prices shall prevail in case of discrepancy.
5. All quotations are considered F.O.B. destination unless alternate shipping terms are clearly identified in the quotation.
6. **BID SUBMISSION:** All quotations must be delivered by the bidder to the office listed below prior to the date and time of the bid opening. Failure of the bidder to deliver the quotations on time will result in bid disqualifications: Department of Administration, Purchasing Division, 2019 Washington Street East, P.O. Box 50130, Charleston, WV 25305-0130



State of West Virginia
 Department of Administration
 Purchasing Division
 2019 Washington Street East
 Post Office Box 50130
 Charleston, WV 25305-0130

Request for Quotation

RFQ NUMBER
709C0009

PAGE
2

ADDRESS CORRESPONDENCE TO ATTENTION OF
MICHAEL AUSTIN 304-558-2402

*709051756 304-346-5301
 WV TRACTOR COMPANY
 PO BOX 473
 CHARLESTON WV 25322

DIVISION OF HIGHWAYS
 EQUIPMENT DIVISION
 ROUTE 33
 BRUSHY FORK ROAD
 BUCKHANNON, WV
 26201 304-472-1750

VENDOR

SHIP TO

DATE PRINTED	TERMS OF SALE	SHIP VIA	F.O.B.	FREIGHT TERMS
01/14/2009				

BID OPENING DATE: 01/28/2009 BID OPENING TIME 01:30PM

LINE	QUANTITY	UOP	CAT. NO.	ITEM NUMBER	UNIT PRICE	AMOUNT
<p>YEAR OR UNTIL SUCH "REASONABLE TIME" THEREAFTER AS IS NECESSARY TO OBTAIN A NEW CONTRACT OR RENEW THE ORIGINAL CONTRACT. THE "REASONABLE TIME" PERIOD SHALL NOT EXCEED TWELVE (12) MONTHS. DURING THIS "REASONABLE TIME" THE VENDOR MAY TERMINATE THIS CONTRACT FOR ANY REASON UPON GIVING THE DIRECTOR OF PURCHASING 30 DAYS WRITTEN NOTICE.</p> <p>UNLESS SPECIFIC PROVISIONS ARE STIPULATED ELSEWHERE IN THIS CONTRACT DOCUMENT, THE TERMS, CONDITIONS AND PRICING SET HEREIN ARE FIRM FOR THE LIFE OF THE CONTRACT.</p> <p>RENEWAL: THIS CONTRACT MAY BE RENEWED UPON THE MUTUAL WRITTEN CONSENT OF THE SPENDING UNIT AND VENDOR, SUBMITTED TO THE DIRECTOR OF PURCHASING THIRTY (30) DAYS PRIOR TO THE EXPIRATION DATE. SUCH RENEWAL SHALL BE IN ACCORDANCE WITH THE TERMS AND CONDITIONS OF THE ORIGINAL CONTRACT AND SHALL BE LIMITED TO TWO (2) ONE (1) YEAR PERIODS.</p> <p>CANCELLATION: THE DIRECTOR OF PURCHASING RESERVES THE RIGHT TO CANCEL THIS CONTRACT IMMEDIATELY UPON WRITTEN NOTICE TO THE VENDOR IF THE COMMODITIES AND/OR SERVICE SUPPLIED ARE OF AN INFERIOR QUALITY OR DO NOT CONFORM TO THE SPECIFICATIONS OF THE BID AND CONTRACT HEREIN.</p> <p>OPEN MARKET CLAUSE: THE DIRECTOR OF PURCHASING MAY AUTHORIZE A SPENDING UNIT TO PURCHASE ON THE OPEN MARKET, WITHOUT THE FILING OF A REQUISITION OR COST ESTIMATE, ITEMS SPECIFIED ON THIS CONTRACT FOR IMMEDIATE DELIVERY IN EMERGENCIES DUE TO UNFORESEEN CAUSES (INCLUDING BUT NOT LIMITED TO DELAYS IN TRANSPORTATION OR AN UNANTICIPATED INCREASE IN THE VOLUME OF WORK.)</p>						

SEE REVERSE SIDE FOR TERMS AND CONDITIONS

SIGNATURE	TELEPHONE	DATE
-----------	-----------	------

TITLE	FEIN	ADDRESS CHANGES TO BE NOTED ABOVE
-------	------	-----------------------------------

WHEN RESPONDING TO RFQ, INSERT NAME AND ADDRESS IN SPACE ABOVE LABELED 'VENDOR'



State of West Virginia
 Department of Administration
 Purchasing Division
 2019 Washington Street East
 Post Office Box 50130
 Charleston, WV 25305-0130

Request for Quotation

RFO NUMBER
709C0009

PAGE
3

ADDRESS CORRESPONDENCE TO ATTENTION OF
MICHAEL AUSTIN 304-558-2402

VENDOR

*709051756 304-346-5301
 WV TRACTOR COMPANY
 PO BOX 473

 CHARLESTON WV 25322

SHIP TO

DIVISION OF HIGHWAYS
 EQUIPMENT DIVISION
 ROUTE 33
 BRUSHY FORK ROAD
 BUCKHANNON, WV
 26201 304-472-1750

DATE PRINTED	TERMS OF SALE	SHIP VIA	F.O.B.	FREIGHT TERMS
01/14/2009				

BID OPENING DATE: **01/28/2009** BID OPENING TIME **01:30PM**

LINE	QUANTITY	UOP	CAT NO.	ITEM NUMBER	UNIT PRICE	AMOUNT
<p>QUANTITIES: QUANTITIES LISTED IN THE REQUISITION ARE APPROXIMATIONS ONLY, BASED ON ESTIMATES SUPPLIED BY THE STATE SPENDING UNIT. IT IS UNDERSTOOD AND AGREED THAT THE CONTRACT SHALL COVER THE QUANTITIES ACTUALLY ORDERED FOR DELIVERY DURING THE TERM OF THE CONTRACT, WHETHER MORE OR LESS THAN THE QUANTITIES SHOWN.</p> <p>ORDERING PROCEDURE: SPENDING UNIT(S) SHALL ISSUE A WRITTEN STATE CONTRACT ORDER (FORM NUMBER WV-39) TO THE VENDOR FOR COMMODITIES COVERED BY THIS CONTRACT. THE ORIGINAL COPY OF THE WV-39 SHALL BE MAILED TO THE VENDOR AS AUTHORIZATION FOR SHIPMENT, A SECOND COPY MAILED TO THE PURCHASING DIVISION, AND A THIRD COPY RETAINED BY THE SPENDING UNIT.</p> <p>BANKRUPTCY: IN THE EVENT THE VENDOR/CONTRACTOR FILES FOR BANKRUPTCY PROTECTION, THIS CONTRACT IS AUTOMATICALLY NULL AND VOID, AND IS TERMINATED WITHOUT FURTHER ORDER.</p> <p>THE TERMS AND CONDITIONS CONTAINED IN THIS CONTRACT SHALL SUPERSEDE ANY AND ALL SUBSEQUENT TERMS AND CONDITIONS WHICH MAY APPEAR ON ANY ATTACHED PRINTED DOCUMENTS SUCH AS PRICE LISTS, ORDER FORMS, SALES AGREEMENTS OR MAINTENANCE AGREEMENTS, INCLUDING ANY ELECTRONIC MEDIUM SUCH AS CD-ROM.</p> <p>REV. 04/11/2001</p> <p>EXHIBIT 10</p> <p>ADDENDUM ACKNOWLEDGEMENT</p> <p style="text-align: right;">709C0009 REQUISITION NO.:</p>						

SEE REVERSE SIDE FOR TERMS AND CONDITIONS

SIGNATURE	TELEPHONE	DATE
-----------	-----------	------

TITLE	FEIN	ADDRESS CHANGES TO BE NOTED ABOVE
-------	------	-----------------------------------

WHEN RESPONDING TO RFQ, INSERT NAME AND ADDRESS IN SPACE ABOVE LABELED 'VENDOR'



State of West Virginia
 Department of Administration
 Purchasing Division
 2019 Washington Street East
 Post Office Box 50130
 Charleston, WV 25305-0130

Request for Quotation

RFQ NUMBER
709C0009

PAGE
4

ADDRESS CORRESPONDENCE TO ATTENTION OF:
MICHAEL AUSTIN
304-558-2402

VENDOR

*709051756 304-346-5301
WV TRACTOR COMPANY
PO BOX 473

CHARLESTON WV 25322

SHIP TO

DIVISION OF HIGHWAYS
EQUIPMENT DIVISION
ROUTE 33
BRUSHY FORK ROAD
BUCKHANNON, WV
26201 **304-472-1750**

DATE PRINTED 01/14/2009	TERMS OF SALE	SHIP VIA	F.O.B.	FREIGHT TERMS
BID OPENING DATE: 01/28/2009		BID OPENING TIME 01:30PM		

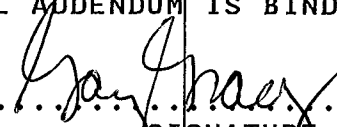
LINE	QUANTITY	UOP	CAT. NO.	ITEM NUMBER	UNIT PRICE	AMOUNT
<p>I HEREBY ACKNOWLEDGE RECEIPT OF THE FOLLOWING CHECKED ADDENDUM(S) AND HAVE MADE THE NECESSARY REVISIONS TO MY PROPOSAL, PLANS AND/OR SPECIFICATION, ETC.</p> <p>ADDENDUM NO.'S:</p> <p>NO. 1</p> <p>NO. 2</p> <p>NO. 3</p> <p>NO. 4</p> <p>NO. 5</p> <p>I UNDERSTAND THAT FAILURE TO CONFIRM THE RECEIPT OF THE ADDENDUM(S) MAY BE CAUSE FOR REJECTION OF BIDS.</p> <p>VENDOR MUST CLEARLY UNDERSTAND THAT ANY VERBAL REPRESENTATION MADE OR ASSUMED TO BE MADE DURING ANY ORAL DISCUSSION HELD BETWEEN VENDOR'S REPRESENTATIVES AND ANY STATE PERSONNEL IS NOT BINDING. ONLY THE INFORMATION ISSUED IN WRITING AND ADDED TO THE SPECIFICATIONS BY AN OFFICIAL ADDENDUM IS BINDING.</p> <p style="text-align: center;">  SIGNATURE West Virginia Tractor Company COMPANY 1/27/09 DATE </p>						

SEE REVERSE SIDE FOR TERMS AND CONDITIONS

SIGNATURE	TELEPHONE	DATE
TITLE	FEIN	ADDRESS CHANGES TO BE NOTED ABOVE

WHEN RESPONDING TO RFQ, INSERT NAME AND ADDRESS IN SPACE ABOVE LABELED 'VENDOR'



State of West Virginia
 Department of Administration
 Purchasing Division
 2019 Washington Street East
 Post Office Box 50130
 Charleston, WV 25305-0130

Request for Quotation

RFQ NUMBER
709C0009

PAGE
6

ADDRESS: CORRESPONDENCE TO ATTENTION OF:
MICHAEL AUSTIN 304-558-2402

VENDOR
 *709051756 304-346-5301
 WV TRACTOR COMPANY
 PO BOX 473
 CHARLESTON WV 25322

SHIP TO
 DIVISION OF HIGHWAYS
 EQUIPMENT DIVISION
 ROUTE 33
 BRUSHY FORK ROAD
 BUCKHANNON, WV
 26201 304-472-1750

DATE PRINTED	TERMS OF SALE	SHIP VIA	F.O.B.	FREIGHT TERMS
01/14/2009				

BID OPENING DATE: **01/28/2009** BID OPENING TIME **01:30PM**

LINE	QUANTITY	UOP	CAT. NO.	ITEM NUMBER	UNIT PRICE	AMOUNT
				Gary Grady		

***** THIS IS THE END OF RFQ 709C0009 ***** TOTAL: _____						

SEE REVERSE SIDE FOR TERMS AND CONDITIONS		
SIGNATURE	TELEPHONE	DATE
TITLE	FEIN	ADDRESS CHANGES TO BE NOTED ABOVE

WHEN RESPONDING TO RFQ, INSERT NAME AND ADDRESS IN SPACE ABOVE LABELED 'VENDOR'

Equipment Division

WV Division of Highways
 PO Box 610
 Buckhannon, WV 26201
 ATTENTION: Kevin Riley (FOUR COPYS)

WVDOT/Division of Highways
 D-1
 1340 Smith St.
 Charleston, WV 25301
 Attn: Melissa Mullens

WVDOT/Division of Highways
 D-2
 Po. Box 880
 Huntington, WV 25712
 Attn: Keith Chapman

WVDOT/Division of Highways
 D-3
 626 Depot St.
 Parkersburg, WV 26101
 Attn: Mark Kimes

WVDOT/Division of Highways
 D-4
 P.O. BOX 2570
 Clarksburg, WV 26301
 Attn: John Bartlett

WVDOT/Division of Highways
 D-5
 PO BOX 99
 BURLINGTON, WV 26710
 Attn: Pat Broadhurst

WVDOT/Division of Highways
 D-6
 1 DOT Drive.
 Moundsville, WV 26041-2353
 Attn: Carol Ryan

WVDOT/Division Highways
 D-7
 Drawer 1228
 Weston, WV 26452
 Attn: Melissa Jordan

WVDOT/Division of Highways
 D-8
 PO Box 1516
 Elkins, WV 26241
 Attn: Debbie Barnett

WVDOT/Division of Highways
 D-9
 103 ½ Church Street
 Lewisburg, WV 24901
 Attn: Keith Brown

WVDOT/Division of Highways
 D-10
 270 Hardwood Lane
 Princeton, WV 24740
 Attn: Tommy Camden

This contract provides for the updating of the manufacturers price lists only, and the percent of discount remains constant throughout the life of contract. If the manufacturer changes parts numbers, add new parts, makes price changes, such changes may be obtained by submitting copies of the manufacturers changes of the published price list to all agencies listed .

Any late changes from the indicated delivery schedule without prior approval by the Division of Highways may be cause for cancellation.

ORDERING INFORMATION: Parts orders against this contract may be placed by the WV DOH Equipment Division and the ten (10) WVDOH District locations as listed . These parts orders may be placed by telephone and /or facsimile.

METHOD OF PAYMENT: The Purchasing card (Visa) is the preferred method of payment. Vendor must supply a credit receipt, sales receipt, or cash register receipt. Vendor shall not charge until parts are shipped.

PURCHASING CARD ACCEPTANCE: The State of West Virginia currently utilizes a VISA purchasing card program which is issued through a local bank. The successful vendor must accept the State of West Virginia VISA purchasing card for payment of all orders placed by any state agency.

DELIVERY: Delivery shall be made to the WVDOT/DIVISION OF HIGHWAYS locations as shown on Page 10.

ALL SHIPMENTS ARE TO BE FOB DESTINATION.

FREIGHT CHARGE WILL ONLY BE ALLOWED FOR 24 HR. SERVICE.

Delivery is an integral part of this contract and failure to comply will be cause to initiate a D.O.T Administrative Form WV-82, Vendor Performance Form. The WV-82 Form will provide a means of officially notifying the Purchasing Division and the vendor of unsatisfactory performance; such as late deliveries, poor service, inadequate parts, supplies, etc.

All warranty claims that require field service shall be done by the vendor at no cost to the WV Division of Highways.

The vendor shall furnish any technical engineering service which might be needed in the proper installation of these parts at no extra cost to the WV Division of Highways.

Material Safety Data Sheet: In addition to meeting current Federal & State laws and requirements concerning Hazardous Chemicals, vendor shall forward with shipment a proper and current Material Safety Date Sheet (MSDS) to the Equipment Division in Buckhannon. Furthermore, vendor shall furnish the State and/or its agencies additional MSDS as requested. By offering and signing a bid response the vendor agrees to these conditions.

The vendor will furnish the State of West Virginia with current price lists and supplement sheets as published by each manufacturer as listed above, manuals and catalogs as may be required. The Department of Highways cannot process invoices for payment until the most current price list is received. Also the State Auditors Office will not approve any invoices for payment without the most current price list. **ALL DETAILS PERTAINING TO THE PRICE LISTS AND SUPPLEMENTS WILL BE HANDLED BY THE PROCURMENT OFFICE OF THE WEST VIRGINIA DIVISION OF HIGHWAYS, CHARLESTON, WV.** The Division of highways reserves the right to revise this section of the contract pertaining the district listing should the amount of the districts increase. The afore mentioned price lists should be forward directly to the addresses listed below:

Vendor must guarantee that he will maintain in his warehouse adequate stock to supply the needs of the WV Division of Highways at all times. ORDERS MUST NOT BE HELD BY THE VENDOR UNTIL A MAXIMUM ORDER POINT HAS BEEN REACHED. Orders should be delivered in a MAXIMUM OF THREE (3) WORKING DAYS OR THE WVDIVISION OF HIGHWAYS PARTS EXPEDITOR MAY GO OFF CONTRACT TO PURCHASE THE PARTS ON THE OPEN MARKET AFTER 5 DAYS WITH THEAPPROVAL OF THE EQUIPMENT DIVISION DIRECTOR OR/THE DISTRICT EQUIPMENT SUPERVISOR OR HIS DESIGNEE. ALL OPEN MARKETPURCHASES MUST BE MADE IN ACCORDANCE WITH THE DEPARTMENT OF ADMINISTRATION PURCHASING DIVISION REGULATIONS.

A restocking charge can only be attached by the vendor with prior mutual consent. Any new parts placed on the market by the manufacturer during the contract period shall be made available to the WV Division of Highways at the Manufacturers published Fleet price less the discount listed above.

All deliveries of merchandise and/or shipping documents at each organization must be properly marked on the outside of the carton showing the WV Division of Highways Purchase Order Number. Any material delivered without this information on the outside of the carton or on documents will be returned to the shipper at shipper expense.

BID SCHEDULE

DESCRIPTION – WAIN ROY SIDE ANGLE COUPLER SYSTEM

	Unit Price
1. NEW MANUAL SWINGER SIDE ANGLE COUPLER SYSTEM, 40 DEGREE ANGLE Powertilt PT-7	<u>\$4,900</u>
2. AUXILLARY HYDRAULIC KIT FOR COUPLER P.H.T.	<u>\$ 800</u>
3. NEW 36" GRADING BUCKET WITH BOLT ON EDGE C & P 36049-D	<u>\$1,500</u>

**MUST HAVE CAPABILITY OF QUICK DISCONNECT BUCKET BY
REMOVAL OF PIN.**

**MUST BE COMPATABLE WITH BUCKET SUPPLIED BY MANUFACTURER
CURRENTLY ON HOE.**

EXISTING WAIN ROY BUCKET MUST FIT UNIT QUOTED.

OPTIONAL

Bucket or Powertilt pin, add..... \$ 265 EA

VENDOR PREFERENCE CERTIFICATE

Certification and application* is hereby made for Preference in accordance with *West Virginia Code*, §5A-3-37. (Does not apply to construction contracts). *West Virginia Code*, §5A-3-37, provides an opportunity for qualifying vendors to request (at the time of bid) preference for their residency status. Such preference is an evaluation method only and will be applied only to the cost bid in accordance with the *West Virginia Code*. This certificate for application is to be used to request such preference. The Purchasing Division will make the determination of the Resident Vendor Preference, if applicable.

- 1. Application is made for 2.5% resident vendor preference for the reason checked:
 Bidder is an individual resident vendor and has resided continuously in West Virginia for four (4) years immediately preceding the date of this certification; or,
 Bidder is a partnership, association or corporation resident vendor and has maintained its headquarters or principal place of business continuously in West Virginia for four (4) years immediately preceding the date of this certification; or 80% of the ownership interest of Bidder is held by another individual, partnership, association or corporation resident vendor who has maintained its headquarters or principal place of business continuously in West Virginia for four (4) years immediately preceding the date of this certification; or,
 Bidder is a nonresident vendor which has an affiliate or subsidiary which employs a minimum of one hundred state residents and which has maintained its headquarters or principal place of business within West Virginia continuously for the four (4) years immediately preceding the date of this certification; or,
- 2. Application is made for 2.5% resident vendor preference for the reason checked:
 Bidder is a resident vendor who certifies that, during the life of the contract, on average at least 75% of the employees working on the project being bid are residents of West Virginia who have resided in the state continuously for the two years immediately preceding submission of this bid; or,
- 3. Application is made for 2.5% resident vendor preference for the reason checked:
 Bidder is a nonresident vendor employing a minimum of one hundred state residents or is a nonresident vendor with an affiliate or subsidiary which maintains its headquarters or principal place of business within West Virginia employing a minimum of one hundred state residents who certifies that, during the life of the contract, on average at least 75% of the employees or Bidder's affiliate's or subsidiary's employees are residents of West Virginia who have resided in the state continuously for the two years immediately preceding submission of this bid; or,
- 4. Application is made for 5% resident vendor preference for the reason checked:
 Bidder meets either the requirement of both subdivisions (1) and (2) or subdivision (1) and (3) as stated above; or,
- 5. Application is made for 3.5% resident vendor preference who is a veteran for the reason checked:
 Bidder is an individual resident vendor who is a veteran of the United States armed forces, the reserves or the National Guard and has resided in West Virginia continuously for the four years immediately preceding the date on which the bid is submitted; or,
- 6. Application is made for 3.5% resident vendor preference who is a veteran for the reason checked:
 Bidder is a resident vendor who is a veteran of the United States armed forces, the reserves or the National Guard, if, for purposes of producing or distributing the commodities or completing the project which is the subject of the vendor's bid and continuously over the entire term of the project, on average at least seventy-five percent of the vendor's employees are residents of West Virginia who have resided in the state continuously for the two immediately preceding years.

Bidder understands if the Secretary of Revenue determines that a Bidder receiving preference has failed to continue to meet the requirements for such preference, the Secretary may order the Director of Purchasing to: (a) reject the bid; or (b) assess a penalty against such Bidder in an amount not to exceed 5% of the bid amount and that such penalty will be paid to the contracting agency or deducted from any unpaid balance on the contract or purchase order.

By submission of this certificate, Bidder agrees to disclose any reasonably requested information to the Purchasing Division and authorizes the Department of Revenue to disclose to the Director of Purchasing appropriate information verifying that Bidder has paid the required business taxes, provided that such information does not contain the amounts of taxes paid nor any other information deemed by the Tax Commissioner to be confidential.

Under penalty of law for false swearing (*West Virginia Code*, §61-5-3), Bidder hereby certifies that this certificate is true and accurate in all respects; and that if a contract is issued to Bidder and if anything contained within this certificate changes during the term of the contract, Bidder will notify the Purchasing Division in writing immediately.

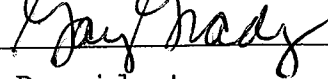
Bidder: West Virginia Tractor Company Signed: 
 Date: 1/27/09 Title: President

*Check any combination of preference consideration(s) indicated above, which you are entitled to receive.

STATE OF WEST VIRGINIA
Purchasing Division

PURCHASING AFFIDAVIT

VENDOR OWING A DEBT TO THE STATE:

West Virginia Code §5A-3-10a provides that: No contract or renewal of any contract may be awarded by the state or any of its political subdivisions to any vendor or prospective vendor when the vendor or prospective vendor or a related party to the vendor or prospective vendor is a debtor and the debt owed is an amount greater than one thousand dollars in the aggregate.

PUBLIC IMPROVEMENT CONTRACTS & DRUG-FREE WORKPLACE ACT:

If this is a solicitation for a public improvement construction contract, the vendor, by its signature below, affirms that it has a written plan for a drug-free workplace policy in compliance with Article 1D, Chapter 21 of the *West Virginia Code*. The vendor **must** make said affirmation with its bid submission. Further, public improvement construction contract may not be awarded to a vendor who does not have a written plan for a drug-free workplace policy in compliance with Article 1D, Chapter 21 of the *West Virginia Code* and who has not submitted that plan to the appropriate contracting authority in timely fashion. For a vendor who is a subcontractor, compliance with Section 5, Article 1D, Chapter 21 of the *West Virginia Code* may take place before their work on the public improvement is begun.

ANTITRUST:

In submitting a bid to any agency for the state of West Virginia, the bidder offers and agrees that if the bid is accepted the bidder will convey, sell, assign or transfer to the state of West Virginia all rights, title and interest in and to all causes of action it may now or hereafter acquire under the antitrust laws of the United States and the state of West Virginia for price fixing and/or unreasonable restraints of trade relating to the particular commodities or services purchased or acquired by the state of West Virginia. Such assignment shall be made and become effective at the time the purchasing agency tenders the initial payment to the bidder.

I certify that this bid is made without prior understanding, agreement, or connection with any corporation, firm, limited liability company, partnership or person or entity submitting a bid for the same materials, supplies, equipment or services and is in all respects fair and without collusion or fraud. I further certify that I am authorized to sign the certification on behalf of the bidder or this bid.

LICENSING:

Vendors must be licensed and in good standing in accordance with any and all state and local laws and requirements by any state or local agency of West Virginia, including, but not limited to, the West Virginia Secretary of State's Office, the West Virginia Tax Department, West Virginia Insurance Commission, or any other state agencies or political subdivision. Furthermore, the vendor must provide all necessary releases to obtain information to enable the Director or spending unit to verify that the vendor is licensed and in good standing with the above entities.

CONFIDENTIALITY:

The vendor agrees that he or she will not disclose to anyone, directly or indirectly, any such personally identifiable information or other confidential information gained from the agency, unless the individual who is the subject of the information consents to the disclosure in writing or the disclosure is made pursuant to the agency's policies, procedures and rules. Vendor further agrees to comply with the Confidentiality Policies and Information Security Accountability Requirements, set forth in <http://www.state.wv.us/admin/purchase/privacy/noticeConfidentiality.pdf>.

Under penalty of law for false swearing (*West Virginia Code* §61-5-3), it is hereby certified that the vendor affirms and acknowledges the information in this affidavit and is in compliance with the requirements as stated.

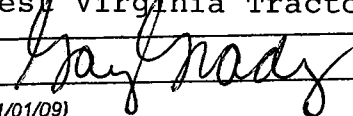
Vendor's Name: West Virginia Tractor Company
Authorized Signature:  Date: 1/27/09

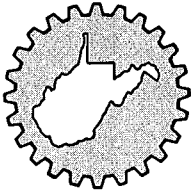

**WEST VIRGINIA
TRACTOR COMPANY**
CONSTRUCTION, MINING, MUNICIPAL & INDUSTRIAL EQUIPMENT

P. O. BOX 473, 214 VIRGINIA ST. W., CHARLESTON, WV 25322/25302 • (304) 346-5301

December 27, 2009

WV DOT-Highways
Equipment Division
P.O. Box 610
Buckhannon, WV 26201

Subj: Tilt Coupler/Bucket Bid - RFQ 709C0009 - Due 1/28/09, 1:30 PM

Ladies and Gentlemen:

We are pleased to offer the following described equipment for your consideration:

POWERTILT Model PT-7 hydraulic bucket rotator attachment complete with an operating weight of 320 lbs., 180 degrees of total swing, 1.5-3 GPM oil flow required, and all standard equipment for use with your Terex TX760B backhoe loaders with extending stick and hammer hydraulics.

PRICE: F.O.B. Buckhannon or Charleston.....\$4,900 EA

P.H.T. diverter valve hydraulic kits to power the rotator through the Terex TX760B extending stick hydraulic circuit.

PRICE: F.O.B. Buckhannon or Charleston.....\$ 800 EA

C & P 36049-D 36" wide ditch cleaning/grading buckets, 11.42 cubic feet heaped and 8.85 cubic feet struck capacity with bolt-on cutting edge.

PRICE: F.O.B. Buckhannon or Charleston.....\$1,500 EA

TOTAL PRICE PER UNIT.....\$7,200 EA

OPTIONAL

Powertilt or bucket pins, add.....\$ 265 EA

Terms: Net 30. Please note that by requiring us to accept payment by credit card, we have added additional money to our bid in order to compensate for the credit card charges we incur.

Availability: Currently about 30-45 days.

The WVDOH currently uses Powertilt attachments on Kobelco excavators and Terex TX760 backhoe loaders. The Powertilt can be used with the C & P grading bucket and the standard Terex buckets and any other pin-on buckets. Our quoted prices do not include installation, and you may have to supply some fittings and hoses.

The Powertilt exceeds your specifications, especially the 180 degree swing in lieu of only 40 degree swing.

Manufacturers' standard warranty terms and conditions will apply to this proposal. Work under warranty to be performed at West Virginia Tractor Company in Charleston.

Please note that, as required by law, we are registered with the West Virginia Dept. of Tax and Revenue and Secretary of State and current with all taxes and license fees.

We qualify for and request the West Virginia Resident Vendor Preference in accordance with West Virginia Code 5A-3-37 and we have completed your Vendor Preference form. Our State of West Virginia Vendor ID Number is 709051756. Our West Virginia Tax ID is 1038-0884.

Thank you very much for your consideration. If you have any questions or need any additional information, please feel free to call me on our toll free number, 1 800 640-8245, at any time. We invite you to visit us at www.wvtractor.com. Again, thanks.

Sincerely,

A handwritten signature in black ink that reads "Gary Grady". The signature is written in a cursive style with a long, sweeping flourish at the end.

Gary W. Grady, President

HELAC
CORPORATION

POWERTILT®

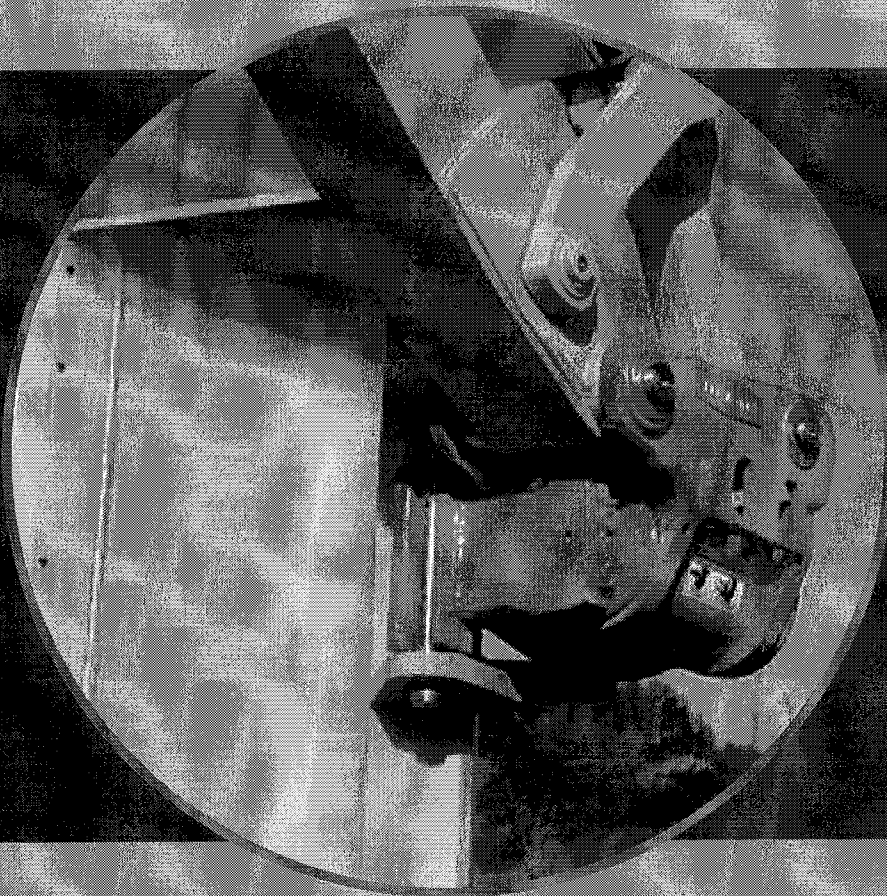

Site development

Landscaping

Ditch cleaning

Demolition

Brushcutting

Specialty applications

Ripping



Save time and increase productivity by 12 percent or more

Helac PowerTilt®, a construction equipment attachment from Helac Corporation, can increase the productivity, profitability and versatility of your backhoe or excavator by simply tilting your attachment instead of moving the entire machine. Over a decade of innovation and engineering design has gone into making PowerTilt an integral solution for increasing work site efficiency.

PowerTilt is ideal for performing every day tasks, or completing jobs that you never thought were possible. Thousands of contractors worldwide have come to rely on PowerTilt since 1990 for cleaning ditches, clearing land, digging beveled trenches, spreading rip-rap, and positioning brushcutters, mowers and hydraulic hammers.

When used in combination with Helac PowerGrip®, a multi-purpose bucket, you can achieve unmatched, hand-like manipulation and dexterity, dramatically maximizing productivity.

Use Helac PowerTilt with a variety of attachments to improve your machine's versatility

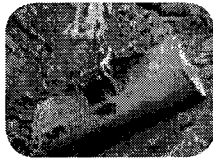

Wide bucket

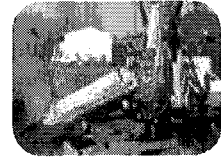

Hydraulic hammer

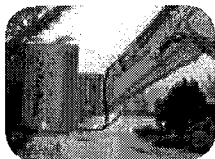

Brushcutter

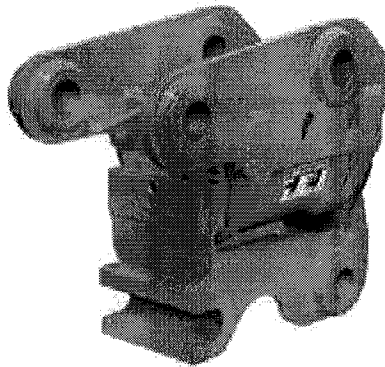

Helac PowerGrip



Narrow bucket

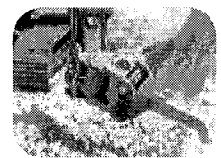

Ripper tooth



"PowerTilts have increased our machine productivity 25 to 30 percent as well as reduced undercarriage wear. We now equip all DNR backhoes and excavators with PowerTilts."

— Don Roller, Equipment Manager,
Washington State Department of Natural Resources

Built from the inside out for durable, reliable performance

Engineered with a unique combination of features, Helac PowerTilt will provide you with the ability to get more work done in less time. Whether you buy, lease or

rent a machine with a PowerTilt, you'll receive a tilting attachment with unmatched versatility and durability.

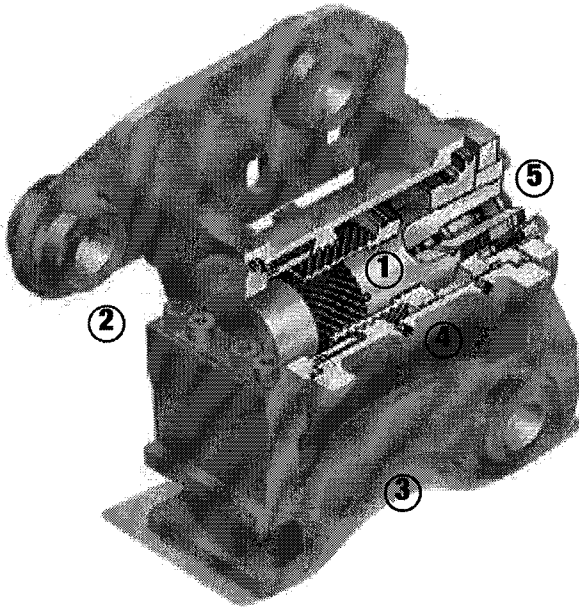

- 1 Maximum Tilt**
Up to 180 degree side-to-side tilt achieved with our exclusive, sliding spline technology.
- 2 Narrow, Compact Configuration**
Use with any of your machine's attachments – even your narrowest trenching bucket.
- 3 Built-in Quick Coupler**
Compatible with your machine's OEM specification buckets and attachments, making tool changes fast and easy.
- 4 Moving Parts Are Enclosed**
No cylinder rods or external moving parts result in low maintenance costs and longer life.
- 5 Internal Cross-Port Relief Valve**
The built-in relief valve provides hydraulic overload protection.

Coupler Options

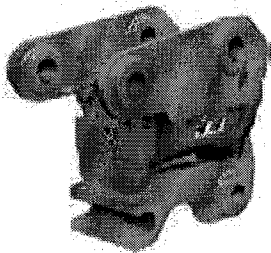

Standard pin-on couplers
All PowerTilt models come with a standard half-hitch coupler. Coupler option varies by model.



Universal couplers
For use with C&P Attachments and WainRoy® quick-hitch buckets

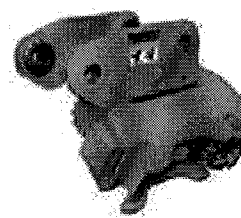

Hydraulic quick couplers
Available through partnerships with attachment manufacturers

Countless ways to perform work faster, safer and easier

The application possibilities for Helac PowerTilt are endless. Our PowerTilt attachment can be used to perform common everyday tasks, or complete jobs you haven't yet tried, allowing you to function with less equipment. The ability to tilt your bucket can reduce the need for specialty equipment on the job site, and at the same time, increase the productivity and profitability of the machines you use on a daily basis. Several common applications for PowerTilt are shown below.

- Site development
- Landscaping
- Ditch cleaning
- Demolition
- Brushcutting
- Specialty applications
- Combined with Helac PowerGrip multi-purpose bucket
- Ripping

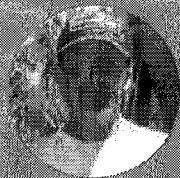
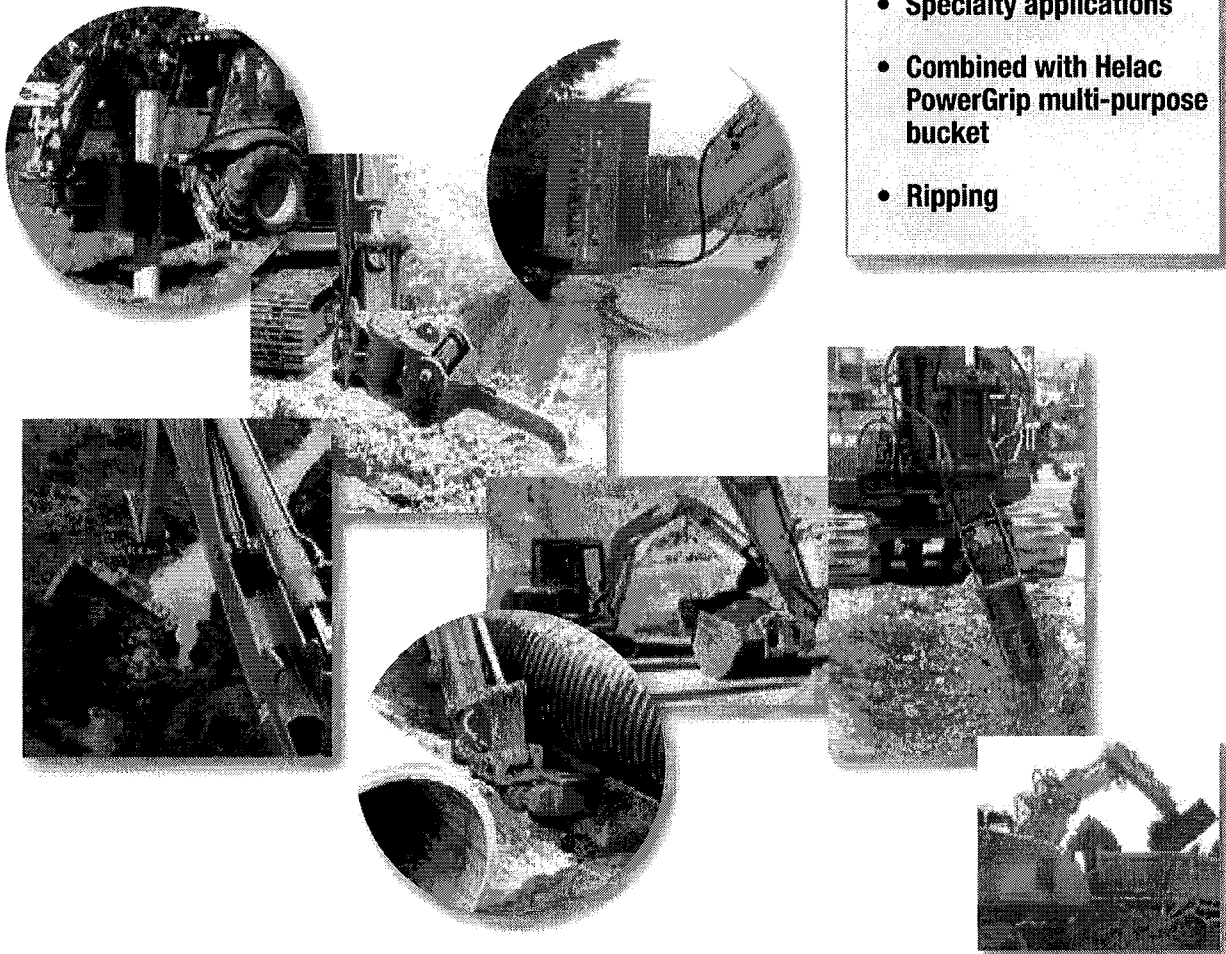

"When I use the PowerTilt/PowerGrip combination, I never have to get out of my seat. I can easily and efficiently manipulate any task on the job site, saving me both time and money."

—Bruce Craik, President,
Nor Cal Construction and Excavating

Models available for a wide variety of machines

Helac PowerTilt is available in a range of models, sized for backhoes and excavators to 75,000 lbs. Each model is engineered for a specific class of machinery and individually customized to fit your machine. If you are purchasing a new or used

machine, it's easy to roll the cost of the PowerTilt into the financing package. You will begin saving time—up to an hour per day—and increasing productivity as soon as your equipment is delivered.

Model		PT-6	PT-6W	PT-7	PT-8	PT-9	PT-10	PT-11	PT-12
Maximum Machine Weight	lb (kg)	8,400 (3,800)	10,500 (4,775)	15,000 (6,800)	20,000 (9,100)	28,700 (13,000)	45,000 (20,000)	60,000 (27,000)	75,000 (34,000)
Approximate PowerTilt Weight	lb (kg)	160 (75)	180 (85)	320 (145)	425 (195)	575 (260)	850 (385)	1,200 (545)	1,500 (680)
Total Tilt		180°*	180°*	180°	180°	134°	134°	134°	134°
Required Oil Flow	gpm (l/min)	.8 – 1.5 (3 – 6)	.8 – 1.5 (3 – 6)	1.5 – 3 (6 – 12)	3 – 5 (12 – 20)	6 – 7 (24 – 28)	6 – 8 (24 – 32)	8 – 11 (32 – 44)	9 – 13 (36 – 52)
Operating Pressure Range		2,200 – 3,750 psi (150 – 250 bar) (Applies to all models)							

Note: A two-way auxiliary hydraulic circuit is required for operation.

* Actual rotation may vary slightly.

Special PowerTilt Designs

Helac PowerTilts are available in several configurations for special applications and for bucket and attachment manufacturers to integrate into their products.

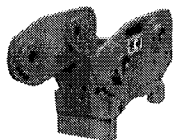

PT Series

Standard housing with welded-on ears. Lower end can be welded directly to a quick coupler or bucket.

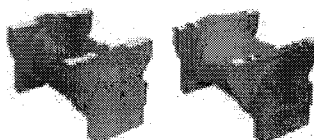

PTA/PTB Series

The housing and shaft are designed for customization. Ideal for integrating quick couplers at both the top and bottom. PTA Series housing is designed for welding; PTB Series incorporates blind drilled and tapped holes for bolt mounting.



Custom Designs

Depending on the order quantity, custom-engineered configurations can be provided.

Our exclusive sliding spline operating technology

PowerTilt uses Helac Corporation's innovative, sliding-spline operating technology to convert linear piston motion into powerful shaft rotation. Each actuator is composed of a housing and two moving parts — the central shaft and piston. Helical spline teeth on the shaft engage matching teeth on the piston's inside diameter. A second set of helical splines on the piston's outside diameter mesh with the gear in the housing.

STARTING POSITION

The piston is completely bottomed out. Bars indicate starting positions of piston and shaft. Arrows indicate directions they will rotate. The housing with integral ring gear remains stationary.

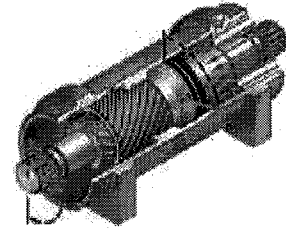
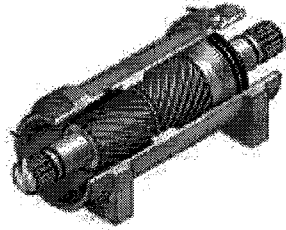

ENDING POSITION

When hydraulic pressure is applied to the piston, it moves axially, while the helical gearing causes the piston and shaft to rotate simultaneously. Applying pressure to the opposite port will return the piston and shaft to their original starting positions.

Helac PowerGrip



Handle multiple tasks with Helac Corporation's PowerGrip multi-purpose backhoe or excavator bucket.

PowerGrip can be used as a trenching, grading or clamshell bucket, or as a grapple or hydraulic thumb. When used in combination with PowerTilt, you will maximize work site efficiency and productivity.

About Helac Corporation

A leader in the fluid power industry for over 30 years, Helac Corporation manufactures a comprehensive line of helical, hydraulic rotary actuators. Our products are used as component parts by OEMs and after-market attachments by the construction equipment industry. Helac rotary actuators are best known for their tremendous torque output, compact dimensions and exceptional load bearing capability. Thousands of worldwide customers in diverse industries depend on Helac actuators for quality, reliability, ease-of-use and durability.



Helac Corporation
225 Battersby Avenue
Enumclaw, WA 98022 USA

U.S. and Canada: 800.PWR.TILT
800.797.8458

Worldwide: 360.802.1039
Fax: 360.802.1030
Email: attachments@helac.com
Web: www.helac.com

PowerTilt - U.S. patent #4906161; Europe #356738;
Japan #2614922

© 2008 Helac Corporation. All rights reserved.

www.helac.com

CG 02-08/10M

[Home](#)
[Rotary Actuators
for OEMs](#)
[Construction
Attachments](#)
[Service](#)
[Company](#)
[Careers](#)
[News & Events](#)
[Contact
Us](#)

PowerTilt Quick Reference Guide

[Print](#)

Quick Reference Guide for Tilting Bucket Attachments

Attachment Features	Helac PowerTilt®	Cylinder Style Tilt Attachments
Total Degrees of Side Swing	180° (PT-6, PT-7, PT-8) 134° (PT-9, PT-10, PT-11, PT-12)	80° – 90°
Constant Swing Speed	Yes	No
Constant Holding Torque Thru Full Rotation	Yes	No
Equal Holding Torque, Both Directions	Yes	No
Integral Hydraulic Protection	Yes	No
Holding Torque Approx. 2X Swing Force	Yes	No
Swivel Linkage Pins	No	Yes
More Than Two Grease Fittings	No	Yes
Standard Mechanical Quick Hitch	Yes	Yes
Digging Depth Limited with Narrow Buckets	No	Yes

[Sitemap](#) / [Feedback](#) / [Request Literature](#)

©2008 Helac Corporation. All rights reserved.



Home

- Rotary Actuators for OEMs
- Construction Attachments
- Service
- Company
- Careers
- News & Events
- Contact Us

PowerTilt Models



Print

PowerTilt Models

Model	Maximum Machine Weight	Approx. Weight	Total Tilt	Required Oil Flow
PT-6	8,400 lb (3,800 kg)	160 lb (75 kg)	180°	0.8-1.5 gpm (3-6 l/min)
PT-6W	10,500 lb (4,775 kg)	180 lb (85 kg)	180°	0.8-1.5 gpm (3-6 l/min)
PT-7	15,000 lb (6,800 kg)	320 lb (145 kg)	180°	1.5-3 gpm (6-12 l/min)
PT-8	20,000 lb (9,100 kg)	425 lb (195 kg)	180°	3-5 gpm (12-20 l/min)
PT-9	28,700 lb (13,000 kg)	575 lb (260 kg)	134°	6-7 gpm (24-28 l/min)
PT-10	45,000 lb (20,000 kg)	850 lb (385 kg)	134°	6-8 gpm (24-32 l/min)
PT-11	60,000 lb (27,000 kg)	1,200 lb (545 kg)	134°	8-11 gpm (32-44 l/min)
PT-12	75,000 lb (35,000 kg)	1,500 lb (680 kg)	134°	9-13 gpm (36-52 l/min)

[Sitemap](#) / [Feedback](#) / [Request Literature](#)

©2008 Helac Corporation. All rights reserved.