



State of West Virginia  
 Department of Administration  
 Purchasing Division  
 2019 Washington Street East  
 Post Office Box 50130  
 Charleston, WV 25305-0130

# Request for Quotation

RFQ NUMBER  
**0890190**

PAGE  
**1**

ADDRESS CORRESPONDENCE TO ATTENTION OF:  
**MICHAEL AUSTIN  
 304-558-2402**

VENDOR

\*621152258      304-842-0367  
**JAMATT INC**  
**RT 1 351 CLEMANS RD**  
  
**FLEMINGTON WV 26347**

SHIP TO

**DIVISION OF HIGHWAYS  
 JOBSITE  
 SEE SPECIFICATIONS**

DATE PRINTED <b>02/17/2009</b>	TERMS OF SALE	SHIP VIA	F.O.B.	FREIGHT TERMS
-----------------------------------	---------------	----------	--------	---------------

BID OPENING DATE: **03/04/2009**      BID OPENING TIME **01:30PM**

LINE	QUANTITY	UOP	CAT. NO.	ITEM NUMBER	UNIT PRICE	AMOUNT
0001	1	LS		570-84		<i>\$19,334.64</i>
<p><b>STRUTURAL STEEL/FOR THE LEFT FORK BRIDGE</b></p> <p>TO PROVIDE GALVANIZED STRUCTURAL STEEL FOR THE LEFT FORK BRIDGE PROJECT NO. S342-30-3.87 FOR THE WEST VIRGINIA DIVISION OF HIGHWAYS PER THE ATTACHED SPECIFICATIONS.</p> <p>PRICE TO INCLUDE DELIVERY TO THE DISTRICT EIGHT LOT, LOCATED ON US ROUTE 219, 1 MILE NORTH OF ELKINS, WV.</p> <p>PRICES MUST BE HELD FIRM FROM AWARD OF CONTRACT TO THE DELIVERY OF MATERIALS.</p> <p>EXHIBIT 10</p> <p>REQUISITION NO.: <i>0890190.....</i></p> <p>ADDENDUM ACKNOWLEDGEMENT</p> <p>I HEREBY ACKNOWLEDGE RECEIPT OF THE FOLLOWING CHECKED ADDENDUM(S) AND HAVE MADE THE NECESSARY REVISIONS TO MY PROPOSAL, PLANS AND/OR SPECIFICATION, ETC.</p> <p>ADDENDUM NO.'S:</p> <p>NO. 1 .....</p> <p>NO. 2 .....</p> <p>NO. 3 .....</p>						

**RECEIVED**  
 2009 MAR -4 A 8:19  
 PURCHASING DIVISION  
 STATE OF WV

SEE REVERSE SIDE FOR TERMS AND CONDITIONS			
SIGNATURE <i>James P. Mattingly</i>	TELEPHONE <i>304-842-0367</i>	DATE <i>02/27/09</i>	
TITLE <i>PRESIDENT</i>	FEIN <i>20-1894398</i>	ADDRESS CHANGES TO BE NOTED ABOVE	

WHEN RESPONDING TO RFQ, INSERT NAME AND ADDRESS IN SPACE ABOVE LABELED 'VENDOR'

**GENERAL TERMS & CONDITIONS  
REQUEST FOR QUOTATION (RFQ) AND REQUEST FOR PROPOSAL (RFP)**

1. Awards will be made in the best interest of the State of West Virginia.
2. The State may accept or reject in part, or in whole, any bid.
3. All quotations are governed by the *West Virginia Code* and the *Legislative Rules* of the Purchasing Division.
4. Prior to any award, the apparent successful vendor must be properly registered with the Purchasing Division and have paid the required \$125 fee.
5. All services performed or goods delivered under State Purchase Order/Contracts are to be continued for the term of the Purchase Order/Contracts, contingent upon funds being appropriated by the Legislature or otherwise being made available. In the event funds are not appropriated or otherwise available for these services or goods, this Purchase Order/Contract becomes void and of no effect after June 30.
6. Payment may only be made after the delivery and acceptance of goods or services.
7. Interest may be paid for late payment in accordance with the *West Virginia Code*.
8. Vendor preference will be granted upon written request in accordance with the *West Virginia Code*.
9. The State of West Virginia is exempt from federal and state taxes and will not pay or reimburse such taxes.
10. The Director of Purchasing may cancel any Purchase Order/Contract upon 30 days written notice to the seller.
11. The laws of the State of West Virginia and the *Legislative Rules* of the Purchasing Division shall govern all rights and duties under the Contract, including without limitation the validity of this Purchase Order/Contract.
12. Any reference to automatic renewal is hereby deleted. The Contract may be renewed only upon mutual written agreement of the parties.
13. **BANKRUPTCY:** In the event the vendor/contractor files for bankruptcy protection, this Contract may be deemed null and void, and terminated without further order.
14. **HIPAA BUSINESS ASSOCIATE ADDENDUM:** The West Virginia State Government HIPAA Business Associate Addendum (BAA), approved by the Attorney General, and available online at the Purchasing Division's web site (<http://www.state.wv.us/admin/purchase/vrc/hipaa.htm>) is hereby made part of the agreement. Provided that, the Agency meets the definition of a Cover Entity (45 CFR §160.103) and will be disclosing Protected Health Information (45 CFR §160.103) to the vendor.
15. **WEST VIRGINIA ALCOHOL & DRUG-FREE WORKPLACE ACT:** If this Contract constitutes a public improvement construction contract as set forth in Article 1D, Chapter 21 of the West Virginia Code ("The West Virginia Alcohol and Drug-Free Workplace Act"), then the following language shall hereby become part of this Contract: "The contractor and its subcontractors shall implement and maintain a written drug-free workplace policy in compliance with the West Virginia Alcohol and Drug-Free Workplace Act, as set forth in Article 1D, Chapter 21 of the West Virginia Code. The contractor and its subcontractors shall provide a sworn statement in writing, under the penalties of perjury, that they maintain a valid drug-free work place policy in compliance with the West Virginia and Drug-Free Workplace Act. It is understood and agreed that this Contract shall be cancelled by the awarding authority if the Contractor: 1) Fails to implement its drug-free workplace policy; 2) Fails to provide information regarding implementation of the contractor's drug-free workplace policy at the request of the public authority; or 3) Provides to the public authority false information regarding the contractor's drug-free workplace policy."

---

**INSTRUCTIONS TO BIDDERS**

1. Use the quotation forms provided by the Purchasing Division.
2. **SPECIFICATIONS:** Items offered must be in compliance with the specifications. Any deviation from the specifications must be clearly indicated by the bidder. Alternates offered by the bidder as **EQUAL** to the specifications must be clearly defined. A bidder offering an alternate should attach complete specifications and literature to the bid. The Purchasing Division may waive minor deviations to specifications.
3. Complete all sections of the quotation form.
4. Unit prices shall prevail in case of discrepancy.
5. All quotations are considered F.O.B. destination unless alternate shipping terms are clearly identified in the quotation.
6. **BID SUBMISSION:** All quotations must be delivered by the bidder to the office listed below prior to the date and time of the bid opening. Failure of the bidder to deliver the quotations on time will result in bid disqualifications: Department of Administration, Purchasing Division, 2019 Washington Street East, P.O. Box 50130, Charleston, WV 25305-0130



State of West Virginia  
 Department of Administration  
 Purchasing Division  
 2019 Washington Street East  
 Post Office Box 50130  
 Charleston, WV 25305-0130

# Request for Quotation

RFQ NUMBER
0890190

PAGE
2

ADDRESS CORRESPONDENCE TO ATTENTION OF
MICHAEL AUSTIN 304-558-2402

VENDOR

\*621152258      304-842-0367  
 JAMATT INC  
 RT 1 351 CLEMANS RD  
 FLEMINGTON WV 26347

SHIP TO

DIVISION OF HIGHWAYS  
 JOBSITE  
 SEE SPECIFICATIONS

DATE PRINTED	TERMS OF SALE	SHIP VIA	F.O.B	FREIGHT TERMS
02/17/2009				

BID OPENING DATE: 03/04/2009      BID OPENING TIME 01:30PM

LINE	QUANTITY	UOP	CAT NO.	ITEM NUMBER	UNIT PRICE	AMOUNT
	NO. 4 .....					
	NO. 5 .....					
<p>I UNDERSTAND THAT FAILURE TO CONFIRM THE RECEIPT OF THE ADDENDUM(S) MAY BE CAUSE FOR REJECTION OF BIDS.</p> <p>VENDOR MUST CLEARLY UNDERSTAND THAT ANY VERBAL REPRESENTATION MADE OR ASSUMED TO BE MADE DURING ANY ORAL DISCUSSION HELD BETWEEN VENDOR'S REPRESENTATIVES AND ANY STATE PERSONNEL IS NOT BINDING. ONLY THE INFORMATION ISSUED IN WRITING AND ADDED TO THE SPECIFICATIONS BY AN OFFICIAL ADDENDUM IS BINDING.</p> <p style="text-align: center;"> <i>James P. Mattingly</i>            .....            SIGNATURE    <i>JAMATT, INC</i>            .....            COMPANY    <i>02/27/09</i>            .....            DATE         </p>						
REV. 11/96						
NOTICE						
A SIGNED BID MUST BE SUBMITTED TO:						
DEPARTMENT OF ADMINISTRATION PURCHASING DIVISION BUILDING 15 2019 WASHINGTON STREET, EAST						

SEE REVERSE SIDE FOR TERMS AND CONDITIONS			
SIGNATURE	TELEPHONE	DATE	
TITLE	FEIN	ADDRESS CHANGES TO BE NOTED ABOVE	

WHEN RESPONDING TO RFQ, INSERT NAME AND ADDRESS IN SPACE ABOVE LABELED 'VENDOR'



State of West Virginia  
 Department of Administration  
 Purchasing Division  
 2019 Washington Street East  
 Post Office Box 50130  
 Charleston, WV 25305-0130

# Request for Quotation

RFQ NUMBER
0890190

PAGE
3

ADDRESS CORRESPONDENCE TO ATTENTION OF
MICHAEL AUSTIN 304-558-2402

VENDOR

\*621152258      304-842-0367  
 JAMATT INC  
 RT 1 351 CLEMANS RD  
 FLEMINGTON WV 26347

SHIP TO

DIVISION OF HIGHWAYS  
 JOBSITE  
 SEE SPECIFICATIONS

DATE PRINTED	TERMS OF SALE	SHIP VIA	F.O.B.	FREIGHT TERMS
02/17/2009				

BID OPENING DATE: 03/04/2009      BID OPENING TIME 01:30PM

LINE	QUANTITY	UOP	CAT NO.	ITEM NUMBER	UNIT PRICE	AMOUNT
				CHARLESTON, WV 25305-0130		
				THE BID SHOULD CONTAIN THIS INFORMATION ON THE FACE OF THE ENVELOPE OR THE BID MAY NOT BE CONSIDERED:		
				SEALED BID		
				BUYER: 33		
				RFQ. NO.: 0890190		
				BID OPENING DATE: -----		
				BID OPENING TIME: -----		
				PLEASE PROVIDE A FAX NUMBER IN CASE IT IS NECESSARY TO CONTACT YOU REGARDING YOUR BID:		
				----- 304-842-2634 -----		
				CONTACT PERSON (PLEASE PRINT CLEARLY):		
				----- JIM MATTINGLY -----		
				***** THIS IS THE END OF RFQ 0890190 ***** TOTAL:		#79,334.64

SEE REVERSE SIDE FOR TERMS AND CONDITIONS		
SIGNATURE	TELEPHONE	DATE
TITLE	FEIN	ADDRESS CHANGES TO BE NOTED ABOVE

WHEN RESPONDING TO RFQ, INSERT NAME AND ADDRESS IN SPACE ABOVE LABELED 'VENDOR'

# JAMATT INC.

Route 1, 351 Cleman's Road  
Flemington, WV 26847

Item No.	Quantity	Description	Unit Price	Amount
1	53,415 lbs	W21x111, Galvanized W-Shaped Structural Steel, AASHTO M270, Grade 50.  Ship: 9 pcs. @ 53'- 5 <sup>5</sup> / <sub>8</sub> " fabricated in accordance with Sketch # 1.	<u>\$ 0.94</u>	<u>\$ 50,210.<sup>10</sup></u>
2	3,000 lbs.	C12x25, Galvanized Structural Steel Channel, AASHTO M270, Grade 50.  Ship: 6 pcs @ 20' -0"	<u>1.13</u>	<u>3,390.<sup>00</sup></u>
3	1,296 lbs.	L 6" x 4" x 1/2" (16.2 #/LF) Galvanized Structural Steel Angle, AASHTO M270, Grade 50.  Ship: 4 pcs. @ 20' -0"	<u>1.00</u>	<u>1,296.<sup>00</sup></u>
4	1,536 lbs.	L 4" x 4" x 1/2" (12.8 #/LF) Galvanized Structural Steel Angle, AASHTO M270, Grade 50.  Ship: 120 pcs @ 1' -0" fabricated in accordance with Sketch # 2	<u>4.92</u>	<u>7,557.<sup>12</sup></u>
5	2,819 lbs.	6" x 6" x 1/2" Galvanized Structural Steel Tubing (35.24 #/LF) ASTM A500.  Ship: 4 pcs. @ 20' -0"	<u>0.75</u>	<u>2,114.<sup>25</sup></u>
6	623 lbs.	6" x 4" x 5/16" Galvanized Structural Steel Tubing (19.08 #/LF), ASTM A500.  Ship: 28 pcs. @ 1'- 2" fabricated in accordance with Sketch # 4	<u>2.37</u>	<u>1,476.<sup>51</sup></u>
7	291 lbs.	1" x 6" Galvanized Structural Steel Bar (20.4 #/LF), AASHTO M270, Grade 50.  Ship: 6 pcs. @ 2'- 4 <sup>1</sup> / <sub>2</sub> " fabricated in accordance with Mark P1 on Sketch # 3.	<u>1.70</u>	<u>494.<sup>70</sup></u>
8	1,224 lbs.	3/4" x 6" Galvanized Structural Steel Bar (15.3 #/LF) AASHTO M270, Grade 50.  Ship: 4 pcs. @ 20' - 0"	<u>0.90</u>	<u>1,101.<sup>60</sup></u>

# JAMATT INC.

Route 1, 351 Cleman's Road  
Remington, WV 26447

Item No.	Quantity	Description	Unit Price	Amount
9	317 lbs.	3/4" x 6" Galvanized Structural Steel Bar (15.3 #/LF) AASHTO M270, Grade 50.  Ship: 6 pcs. @ 3'- 5 1/2" fabricated in accordance with Mark P2 on Sketch # 3.	<u>1.62</u>	<u>513.54</u>
10	2,670 lbs.	Galvanized #8 Reinforcing Steel Bars (2.67 #/LF) AASHTO M31, Grade 60.  Ship: 50 pcs. @ 20' -0"	<u>1.75</u>	<u>4,672.50</u>
11	2,086 lbs.	Galvanized #5 Reinforcing Steel Bars (1.043 #/LF) AASHTO M31, Grade 60.  Ship: 100 pcs. @ 20' -0"	<u>3.12</u>	<u>6,508.32</u>
<b>TOTAL</b>				<u>\$ 79,334.64</u>
<ol style="list-style-type: none"> <li>1. The above listed materials are to be delivered to the WVDOH, District Eight lot, located on US Route 219, approximately 1 mile north of Elkins WV.</li> <li>2. The District Eight Storekeeper must be notified at (304) 637-0226 at least 48 hours in advance of delivery to provide necessary personnel and equipment for unloading.</li> <li>3. Delivery will only be accepted during normal working hours of 7:30am to 4:00pm, Monday - Friday.</li> <li>4. All galvanizing shall be in accordance with AASHTO MIII.</li> <li>5. Steel designated as AASHTO M270 shall conform to Section S4. Non-Fracture-Critical, Zone 2, toughness testing and requirements.</li> <li>6. The project is scheduled for August, 2009.</li> </ol>				

W. Va. Dept. of Transportation—Division of Highways  
District 8; PO Box 1516  
Elkins, WV 26241

PO No. 089-0190  
Page No. 5 of 8  
Sketch No. 1

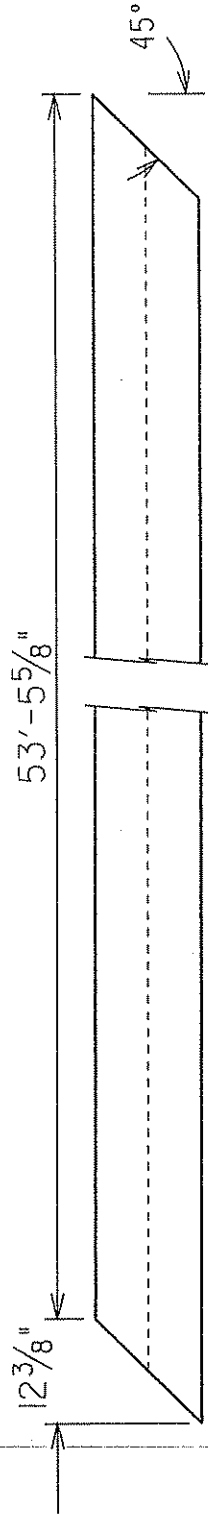

GALVANIZED W21X11 W-BEAM  
(9- Required)

W. Va. Department of Transportation  
Division of Highways, District 8  
PO Box 1516  
Elkins, WV 26241  
RPO No. 089-0190  
Page No. 6 of 8  
Sketch No. 2

ALL HOLES  $1\frac{3}{16}$ " DIAMETER

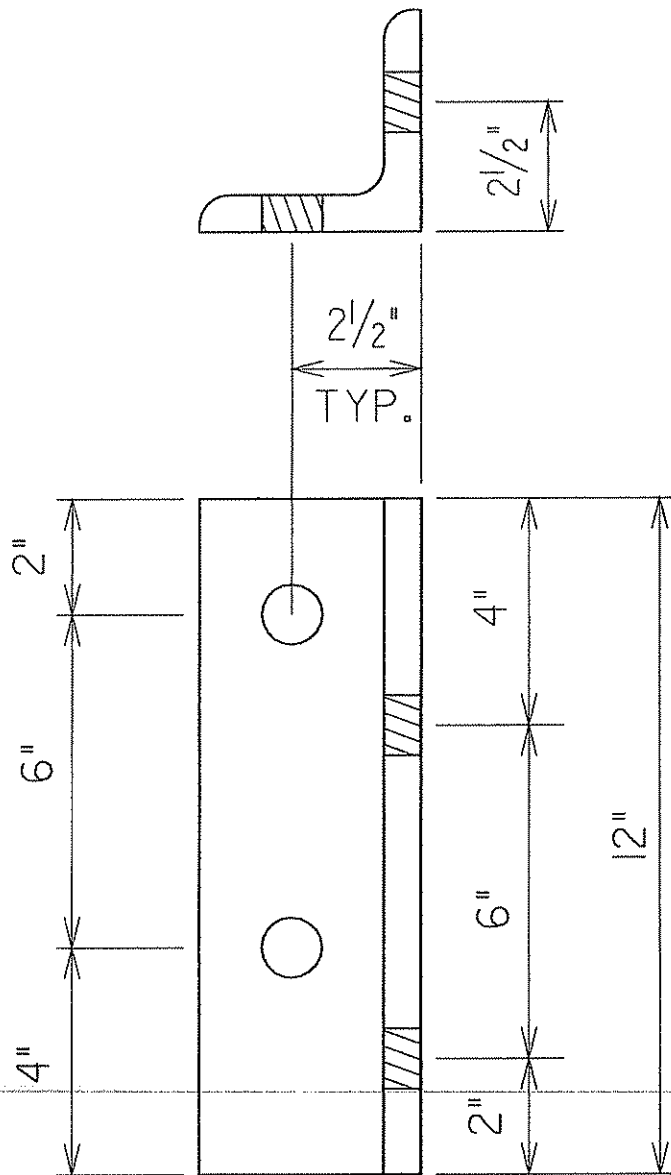

GALVANIZED CLIP ANGLE

ANGLE 4"x4"x1/2" - 120 REQUIRED



W. Va. Department of Transportation—Division of Highways  
District 8, PO Box 1516, Elkins, WV 26241

PO No. 089-0190

Page No. 7 of 8

Sketch No. 3

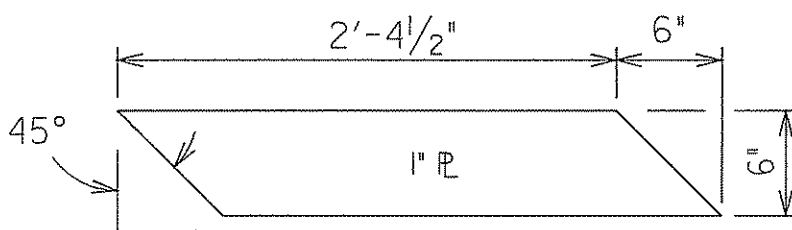

GALVANIZED 1" PLATE - MARK P1  
( 6 - Required )

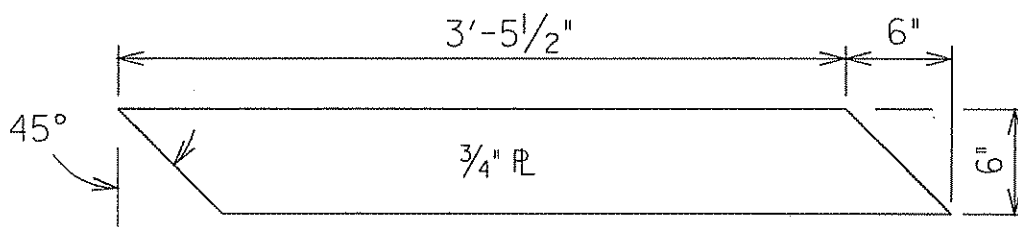

GALVANIZED 3/4" PLATE - MARK P2  
( 6 - Required )

W. Va. Department of Transportation—Division of Highways  
District 8, PO Box 1516, Elkins, WV 26241

PO No. 089-0190

Page No. 8 of 8

Sketch No. 4

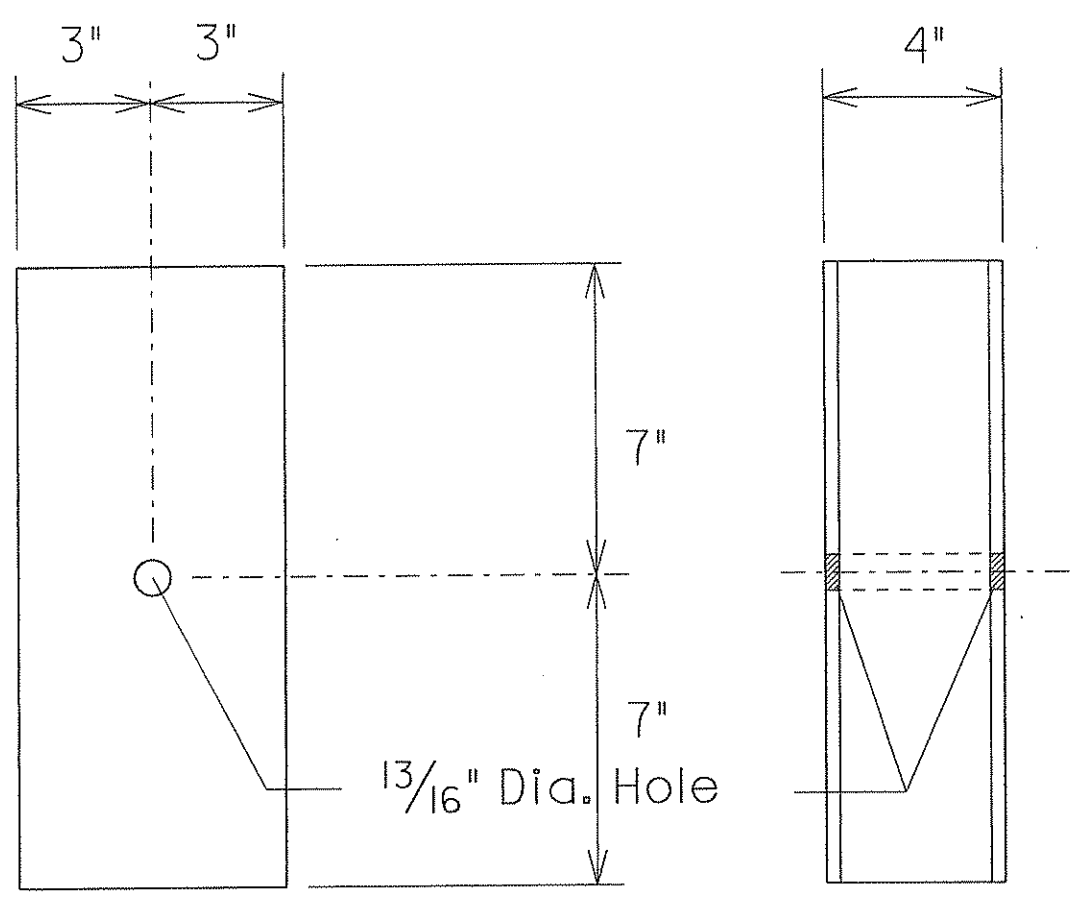

Galvanized  
6"x 4"x 5/16" Structural Tubing  
28 Required

VENDOR PREFERENCE CERTIFICATE

Certification and application\* is hereby made for Preference in accordance with West Virginia Code, §5A-3-37. (Does not apply to construction contracts). West Virginia Code, §5A-3-37, provides an opportunity for qualifying vendors to request (at the time of bid) preference for their residency status. Such preference is an evaluation method only and will be applied only to the cost bid in accordance with the West Virginia Code. This certificate for application is to be used to request such preference. The Purchasing Division will make the determination of the Resident Vendor Preference, if applicable.

- 1. Application is made for 2.5% resident vendor preference for the reason checked: Bidder is an individual resident vendor and has resided continuously in West Virginia for four (4) years immediately preceding the date of this certification; or, Bidder is a partnership, association or corporation resident vendor and has maintained its headquarters or principal place of business continuously in West Virginia for four (4) years immediately preceding the date of this certification; or 80% of the ownership interest of Bidder is held by another individual, partnership, association or corporation resident vendor who has maintained its headquarters or principal place of business continuously in West Virginia for four (4) years immediately preceding the date of this certification; or, Bidder is a nonresident vendor which has an affiliate or subsidiary which employs a minimum of one hundred state residents and which has maintained its headquarters or principal place of business within West Virginia continuously for the four (4) years immediately preceding the date of this certification; or,
2. Application is made for 2.5% resident vendor preference for the reason checked: Bidder is a resident vendor who certifies that, during the life of the contract, on average at least 75% of the employees working on the project being bid are residents of West Virginia who have resided in the state continuously for the two years immediately preceding submission of this bid; or,
3. Application is made for 2.5% resident vendor preference for the reason checked: Bidder is a nonresident vendor employing a minimum of one hundred state residents or is a nonresident vendor with an affiliate or subsidiary which maintains its headquarters or principal place of business within West Virginia employing a minimum of one hundred state residents who certifies that, during the life of the contract, on average at least 75% of the employees or Bidder's affiliate's or subsidiary's employees are residents of West Virginia who have resided in the state continuously for the two years immediately preceding submission of this bid; or,
4. Application is made for 5% resident vendor preference for the reason checked: Bidder meets either the requirement of both subdivisions (1) and (2) or subdivision (1) and (3) as stated above; or,
5. Application is made for 3.5% resident vendor preference who is a veteran for the reason checked: Bidder is an individual resident vendor who is a veteran of the United States armed forces, the reserves or the National Guard and has resided in West Virginia continuously for the four years immediately preceding the date on which the bid is submitted; or,
6. Application is made for 3.5% resident vendor preference who is a veteran for the reason checked: Bidder is a resident vendor who is a veteran of the United States armed forces, the reserves or the National Guard, if, for purposes of producing or distributing the commodities or completing the project which is the subject of the vendor's bid and continuously over the entire term of the project, on average at least seventy-five percent of the vendor's employees are residents of West Virginia who have resided in the state continuously for the two immediately preceding years:

Bidder understands if the Secretary of Revenue determines that a Bidder receiving preference has failed to continue to meet the requirements for such preference, the Secretary may order the Director of Purchasing to: (a) reject the bid; or (b) assess a penalty against such Bidder in an amount not to exceed 5% of the bid amount and that such penalty will be paid to the contracting agency or deducted from any unpaid balance on the contract or purchase order.

By submission of this certificate, Bidder agrees to disclose any reasonably requested information to the Purchasing Division and authorizes the Department of Revenue to disclose to the Director of Purchasing appropriate information verifying that Bidder has paid the required business taxes, provided that such information does not contain the amounts of taxes paid nor any other information deemed by the Tax Commissioner to be confidential.

Under penalty of law for false swearing (West Virginia Code, §61-5-3), Bidder hereby certifies that this certificate is true and accurate in all respects; and that if a contract is issued to Bidder and if anything contained within this certificate changes during the term of the contract, Bidder will notify the Purchasing Division in writing immediately.

Bidder: JAMATT, INC. Signed: [Signature]
Date: 02/27/09 Title: PRESIDENT

\*Check any combination of preference consideration(s) indicated above, which you are entitled to receive.

STATE OF WEST VIRGINIA  
Purchasing Division**PURCHASING AFFIDAVIT****VENDOR OWING A DEBT TO THE STATE:**

*West Virginia Code* §5A-3-10a provides that: No contract or renewal of any contract may be awarded by the state or any of its political subdivisions to any vendor or prospective vendor when the vendor or prospective vendor or a related party to the vendor or prospective vendor is a debtor and the debt owed is an amount greater than one thousand dollars in the aggregate.

**PUBLIC IMPROVEMENT CONTRACTS & DRUG-FREE WORKPLACE ACT:**

If this is a solicitation for a public improvement construction contract, the vendor, by its signature below, affirms that it has a written plan for a drug-free workplace policy in compliance with Article 1D, Chapter 21 of the *West Virginia Code*. The vendor **must** make said affirmation with its bid submission. Further, public improvement construction contract may not be awarded to a vendor who does not have a written plan for a drug-free workplace policy in compliance with Article 1D, Chapter 21 of the *West Virginia Code* and who has not submitted that plan to the appropriate contracting authority in timely fashion. For a vendor who is a subcontractor, compliance with Section 5, Article 1D, Chapter 21 of the *West Virginia Code* may take place before their work on the public improvement is begun.

**ANTITRUST:**

In submitting a bid to any agency for the state of West Virginia, the bidder offers and agrees that if the bid is accepted the bidder will convey, sell, assign or transfer to the state of West Virginia all rights, title and interest in and to all causes of action it may now or hereafter acquire under the antitrust laws of the United States and the state of West Virginia for price fixing and/or unreasonable restraints of trade relating to the particular commodities or services purchased or acquired by the state of West Virginia. Such assignment shall be made and become effective at the time the purchasing agency tenders the initial payment to the bidder.

I certify that this bid is made without prior understanding, agreement, or connection with any corporation, firm, limited liability company, partnership or person or entity submitting a bid for the same materials, supplies, equipment or services and is in all respects fair and without collusion or fraud. I further certify that I am authorized to sign the certification on behalf of the bidder or this bid.

**LICENSING:**

Vendors must be licensed and in good standing in accordance with any and all state and local laws and requirements by any state or local agency of West Virginia, including, but not limited to, the West Virginia Secretary of State's Office, the West Virginia Tax Department, West Virginia Insurance Commission, or any other state agencies or political subdivision. Furthermore, the vendor must provide all necessary releases to obtain information to enable the Director or spending unit to verify that the vendor is licensed and in good standing with the above entities.

**CONFIDENTIALITY:**

The vendor agrees that he or she will not disclose to anyone, directly or indirectly, any such personally identifiable information or other confidential information gained from the agency, unless the individual who is the subject of the information consents to the disclosure in writing or the disclosure is made pursuant to the agency's policies, procedures and rules. Vendor further agrees to comply with the Confidentiality Policies and Information Security Accountability Requirements, set forth in <http://www.state.wv.us/admin/purchase/privacy/noticeConfidentiality.pdf>.

Under penalty of law for false swearing (*West Virginia Code* §61-5-3), it is hereby certified that the vendor affirms and acknowledges the information in this affidavit and is in compliance with the requirements as stated.

Vendor's Name: JAMATT, INC.  
Authorized Signature:  Date: 02/27/09