



State of West Virginia
 Department of Administration
 Purchasing Division
 2019 Washington Street East
 Post Office Box 50130
 Charleston, WV 25305-0130

Request for Quotation

RFQ NUMBER
06900188

PAGE
1

ADDRESS CORRESPONDENCE TO ATTENTION OF
MICHAEL AUSTIN 304-558-2402

VENDOR

*709055926 304-464-4441
 CARR CONCRETE CORPORATION
 PO BOX 265

 WAVERLY WV 26184-0265

SHIP TO

DIVISION OF HIGHWAYS
 JOBSITE
 SEE SPECIFICATIONS

RECEIVED
 DEC 12 2008

BY:

DATE PRINTED	TERMS OF SALE	SHIP VIA	F.O.B	FREIGHT TERMS
12/09/2008				

BID OPENING DATE: **01/07/2009** BID OPENING TIME **01:30PM**

LINE	QUANTITY	UOP	CAT. NO.	ITEM NUMBER	UNIT PRICE	AMOUNT
0001	48	LF		968-27		
<p>PRECAST BOX CULVERT 20' SPAN BY 10'RISE</p> <p>TO PROVIDE (48) FORTY- EIGHT PRECAST BOX CULVERT 20' SPAN BY 10' RISE (HL-93 LOADING, LESS THAN 2' OF FILL) SECTION LENGTH AS RECOMMENDED BY FABRICATOR.</p> <p>ALL PRECAST CONCRETE BOX SECTIONS SHALL BE MANUFACTURED IN ACCORDANCE WITH THE AMERICAN ASSOCIATION OF STATE HIGHWAY AND TRANSPORTATION OFFICIAL STANDARD SPECIFICATIONS. ALL WEILDED WIRE REINFORCEMENT AND REINFORCING STEEL BARS WHERE ALLOWED SHALL BE COATED IN ACCORDANCE WITH AASHTO M284M-29 (EPOCY COATING) DRAWING ARE ATTACHED.</p> <p>DELIVER TO WEST VIRGINIA DIVISION OF HIGHWAYS: PICKENPAW RUN BRIDGE, PRICETOWN, WV</p> <p>PLEASE CALL 24 HOURS BEFORE ANY DELIVERY @ 304-843-365</p> <p>EXHIBIT 10</p> <p style="text-align: right;">REQUISITION NO.: 06900188...</p> <p>ADDENDUM ACKNOWLEDGEMENT</p> <p>I HEREBY ACKNOWLEDGE RECEIPT OF THE FOLLOWING CHECKED ADDENDUM(S) AND HAVE MADE THE NECESSARY REVISIONS TO MY PROPOSAL, PLANS AND/OR SPECIFICATION, ETC.</p>						

SEE REVERSE SIDE FOR TERMS AND CONDITIONS			
SIGNATURE	TELEPHONE	DATE	
<i>Robert "Burr" Staley</i>	1-304-464-4441	1-20-09	
TITLE	FEIN	ADDRESS CHANGES TO BE NOTED ABOVE	
Project Manager	55-0685425		

WHEN RESPONDING TO RFQ, INSERT NAME AND ADDRESS IN SPACE ABOVE LABELED 'VENDOR'

**GENERAL TERMS & CONDITIONS
REQUEST FOR QUOTATION (RFQ) AND REQUEST FOR PROPOSAL (RFP)**

1. Awards will be made in the best interest of the State of West Virginia.
2. The State may accept or reject in part, or in whole, any bid.
3. All quotations are governed by the *West Virginia Code* and the *Legislative Rules* of the Purchasing Division.
4. Prior to any award, the apparent successful vendor must be properly registered with the Purchasing Division and have paid the required \$125 fee.
5. All services performed or goods delivered under State Purchase Order/Contracts are to be continued for the term of the Purchase Order/Contracts, contingent upon funds being appropriated by the Legislature or otherwise being made available. In the event funds are not appropriated or otherwise available for these services or goods, this Purchase Order/Contract becomes void and of no effect after June 30.
6. Payment may only be made after the delivery and acceptance of goods or services.
7. Interest may be paid for late payment in accordance with the *West Virginia Code*.
8. Vendor preference will be granted upon written request in accordance with the *West Virginia Code*.
9. The State of West Virginia is exempt from federal and state taxes and will not pay or reimburse such taxes.
10. The Director of Purchasing may cancel any Purchase Order/Contract upon 30 days written notice to the seller.
11. The laws of the State of West Virginia and the *Legislative Rules* of the Purchasing Division shall govern all rights and duties under the Contract, including without limitation the validity of this Purchase Order/Contract.
12. Any reference to automatic renewal is hereby deleted. The Contract may be renewed only upon mutual written agreement of the parties.
13. **BANKRUPTCY:** In the event the vendor/contractor files for bankruptcy protection, this Contract may be deemed null and void, and terminated without further order.
14. **HIPAA BUSINESS ASSOCIATE ADDENDUM:** The West Virginia State Government HIPAA Business Associate Addendum (BAA), approved by the Attorney General, and available online at the Purchasing Division's web site (<http://www.state.wv.us/admin/purchase/vrc/hipaa.htm>) is hereby made part of the agreement. Provided that, the Agency meets the definition of a Cover Entity (45 CFR §160.103) and will be disclosing Protected Health Information (45 CFR §160.103) to the vendor.
15. **WEST VIRGINIA ALCOHOL & DRUG-FREE WORKPLACE ACT:** If this Contract constitutes a public improvement construction contract as set forth in Article 1D, Chapter 21 of the West Virginia Code ("The West Virginia Alcohol and Drug-Free Workplace Act"), then the following language shall hereby become part of this Contract: "The contractor and its subcontractors shall implement and maintain a written drug-free workplace policy in compliance with the West Virginia Alcohol and Drug-Free Workplace Act, as set forth in Article 1D, Chapter 21 of the West Virginia Code. The contractor and its subcontractors shall provide a sworn statement in writing, under the penalties of perjury, that they maintain a valid drug-free work place policy in compliance with the West Virginia and Drug-Free Workplace Act. It is understood and agreed that this Contract shall be cancelled by the awarding authority if the Contractor: 1) Fails to implement its drug-free workplace policy; 2) Fails to provide information regarding implementation of the contractor's drug-free workplace policy at the request of the public authority; or 3) Provides to the public authority false information regarding the contractor's drug-free workplace policy."

INSTRUCTIONS TO BIDDERS

1. Use the quotation forms provided by the Purchasing Division.
2. **SPECIFICATIONS:** Items offered must be in compliance with the specifications. Any deviation from the specifications must be clearly indicated by the bidder. Alternates offered by the bidder as **EQUAL** to the specifications must be clearly defined. A bidder offering an alternate should attach complete specifications and literature to the bid. The Purchasing Division may waive minor deviations to specifications.
3. Complete all sections of the quotation form.
4. Unit prices shall prevail in case of discrepancy.
5. All quotations are considered F.O.B. destination unless alternate shipping terms are clearly identified in the quotation.
6. **BID SUBMISSION:** All quotations must be delivered by the bidder to the office listed below prior to the date and time of the bid opening. Failure of the bidder to deliver the quotations on time will result in bid disqualifications: Department of Administration, Purchasing Division, 2019 Washington Street East, P.O. Box 50130, Charleston, WV 25305-0130



State of West Virginia
 Department of Administration
 Purchasing Division
 2019 Washington Street East
 Post Office Box 50130
 Charleston, WV 25305-0130

Request for Quotation

RFQ NUMBER
 06900188

PAGE
 3

ADDRESS CORRESPONDENCE TO ATTENTION OF
 MICHAEL AUSTIN
 304-558-2402

VENDOR

*709055926 304-464-4441
 CARR CONCRETE CORPORATION
 PO BOX 265
 WAVERLY WV 26184-0265

SHIP TO

DIVISION OF HIGHWAYS
 JOBSITE
 SEE SPECIFICATIONS

DATE PRINTED	TERMS OF SALE	SHIP VIA	F.O.B.	FREIGHT TERMS
12/09/2008				

BID OPENING DATE: 01/07/2009 BID OPENING TIME 01:30PM

LINE	QUANTITY	UOP	CAT NO	ITEM NUMBER	UNIT PRICE	AMOUNT
<p>NOTICE</p> <p>A SIGNED BID MUST BE SUBMITTED TO:</p> <p>DEPARTMENT OF ADMINISTRATION PURCHASING DIVISION BUILDING 15 2019 WASHINGTON STREET, EAST CHARLESTON, WV 25305-0130</p> <p>THE BID SHOULD CONTAIN THIS INFORMATION ON THE FACE OF THE ENVELOPE OR THE BID MAY NOT BE CONSIDERED:</p> <p>SEALED BID</p> <p>BUYER: 33</p> <p>RFQ. NO.: 06900188</p> <p>BID OPENING DATE: 1-14-2009</p> <p>BID OPENING TIME: 1:30pm</p> <p>PLEASE PROVIDE A FAX NUMBER IN CASE IT IS NECESSARY TO CONTACT YOU REGARDING YOUR BID:</p> <p>1-304-464-4013</p> <p>CONTACT PERSON (PLEASE PRINT CLEARLY): Burr Stanley</p>						

SEE REVERSE SIDE FOR TERMS AND CONDITIONS

SIGNATURE _____ TELEPHONE 1-304-464-4441 DATE 1-20-09

TITLE Project Manager FEIN 55-0685425 ADDRESS CHANGES TO BE NOTED ABOVE

WHEN RESPONDING TO RFQ, INSERT NAME AND ADDRESS IN SPACE ABOVE LABELED 'VENDOR'



State of West Virginia
 Department of Administration
 Purchasing Division
 2019 Washington Street East
 Post Office Box 50130
 Charleston, WV 25305-0130

Request for Quotation

RFQ NUMBER
06900188

PAGE
2

ADDRESS CORRESPONDENCE TO ATTENTION OF
**MICHAEL AUSTIN
 304-558-2402**

TENDER

*709055926 304-464-4441
CARR CONCRETE CORPORATION
PO BOX 265

WAVERLY WV 26184-0265

SHIP TO

**DIVISION OF HIGHWAYS
 JOBSITE
 SEE SPECIFICATIONS**

DATE PRINTED 12/09/2008	TERMS OF SALE	SHIP VIA	F.O.B.	FREIGHT TERMS
-----------------------------------	---------------	----------	--------	---------------

BID OPENING DATE: **01/07/2009** BID OPENING TIME **01:30PM**

LINE	QUANTITY	UOP	CAT. NO.	ITEM NUMBER	UNIT PRICE	AMOUNT
<p>ADDENDUM NO.'S:</p> <p>NO. 1 NO. 2 NO. 3 NO. 4 NO. 5</p> <p>I UNDERSTAND THAT FAILURE TO CONFIRM THE RECEIPT OF THE ADDENDUM(S) MAY BE CAUSE FOR REJECTION OF BIDS.</p> <p>VENDOR MUST CLEARLY UNDERSTAND THAT ANY VERBAL REPRESENTATION MADE OR ASSUMED TO BE MADE DURING ANY ORAL DISCUSSION HELD BETWEEN VENDOR'S REPRESENTATIVES AND ANY STATE PERSONNEL IS NOT BINDING. ONLY THE INFORMATION ISSUED IN WRITING AND ADDED TO THE SPECIFICATIONS BY AN OFFICIAL ADDENDUM IS BINDING.</p> <p style="text-align: right;"> <i>Robert "Cur" Stanley</i> SIGNATURE <i>Carr Concrete</i> COMPANY 1-20-2009 DATE </p> <p>REV. 11/96</p>						

SEE REVERSE SIDE FOR TERMS AND CONDITIONS		
SIGNATURE	TELEPHONE 1-304-464-4441	DATE 1-20-09
TITLE Project Manager	FEIN 55-0685425	ADDRESS CHANGES TO BE NOTED ABOVE

WHEN RESPONDING TO RFQ, INSERT NAME AND ADDRESS IN SPACE ABOVE LABELED 'VENDOR'



State of West Virginia
 Department of Administration
 Purchasing Division
 2019 Washington Street East
 Post Office Box 50130
 Charleston, WV 25305-0130

Request for Quotation

RFQ NUMBER
06900188

PAGE
4

ADDRESS CORRESPONDENCE TO ATTENTION OF
MICHAEL AUSTIN 304-558-2402

VENDOR

*709055926 304-464-4441
 CARR CONCRETE CORPORATION
 PO BOX 265
 WAVERLY WV 26184-0265

SHIP TO

DIVISION OF HIGHWAYS
 JOBSITE
 SEE SPECIFICATIONS

DATE PRINTED	TERMS OF SALE	SHIP VIA	F.O.B.	FREIGHT TERMS
12/09/2008				

BID OPENING DATE: 01/07/2009 BID OPENING TIME 01:30PM

LINE	QUANTITY	UOP	CAT NO	ITEM NUMBER	UNIT PRICE	AMOUNT
***** THIS IS THE END OF RFQ 06900188 ***** TOTAL:						

SEE REVERSE SIDE FOR TERMS AND CONDITIONS

SIGNATURE	TELEPHONE	DATE
<i>Project Manager</i>	1-304-464-4441	1-20-2009
TITLE	FEIN	ADDRESS CHANGES TO BE NOTED ABOVE
	55-0685425	

WHEN RESPONDING TO RFQ, INSERT NAME AND ADDRESS IN SPACE ABOVE LABELED 'VENDOR'

STATE PROJECT NUMBER	SECTION NUMBER	COUNTY	SHEET NUMBER	TOTAL SHEETS
001-1-30	N/A	WYOMING	11	15

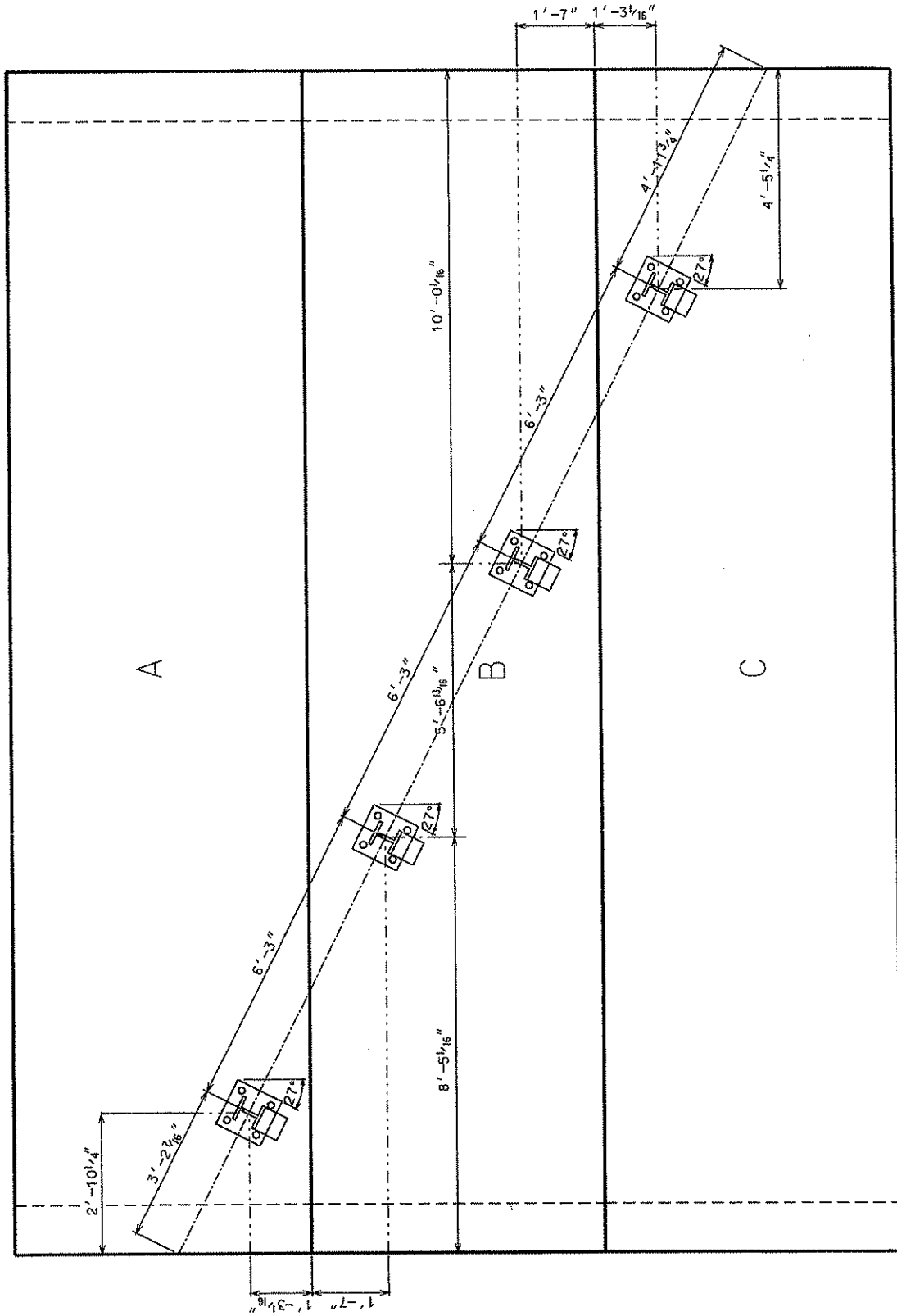

THE WEST VIRGINIA DEPARTMENT OF TRANSPORTATION		DIVISION OF HIGHWAYS	
GUARDRAIL LAYOUT AND DETAILS			
CONCRETE CURB BRIDGE			
DATE	BY	DATE	BY
MAR 02-07	JOS	MAR 02-07	JOS
MAR 02-07	JOS	MAR 02-07	JOS
MAR 02-07	JOS	MAR 02-07	JOS

NOTE:
UPSTREAM AND DOWNSTREAM ATTACHMENTS
ARE THE SAME EXCEPT ROTATED 180°

STATE PROJECT NUMBER	FEDERAL PROJECT NUMBER	STATE PROJECT NUMBER	COUNTY	SHEET NO.	TOTAL SHEETS
2322-H-130	R/A	6	WETZEL	19	25

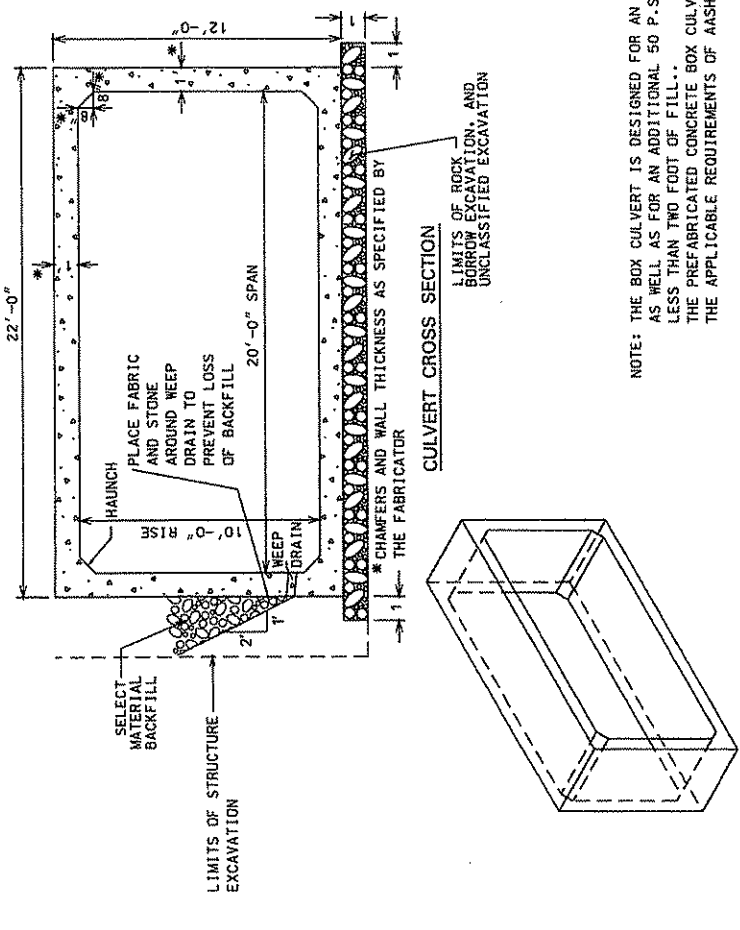
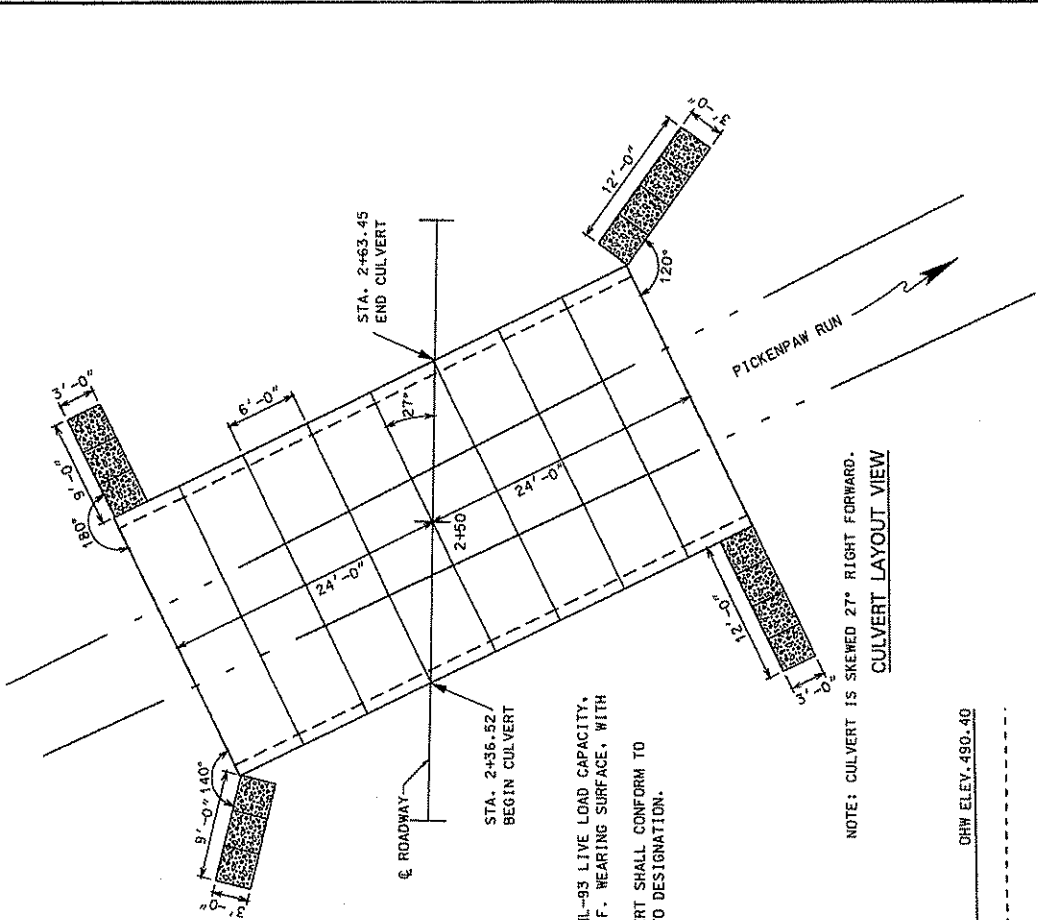

NOTE: THE BOX CULVERT IS DESIGNED FOR AN HL-93 LIVE LOAD CAPACITY, AS WELL AS FOR AN ADDITIONAL 50 P.S.F. WEARING SURFACE, WITH LESS THAN TWO FEET OF FILL. THE PREFABRICATED CONCRETE BOX CULVERT SHALL CONFORM TO THE APPLICABLE REQUIREMENTS OF AASHTO DESIGNATION.

JOINTS BETWEEN BOX SECTIONS SHALL BE SEALED FLUSH, INSIDE AND OUTSIDE, USING A FLEXIBLE PLASTIC MATERIAL, RUBBER RESIN CONCEAL AND/OR GROUT AS RECOMMENDED BY THE BOX CULVERT MANUFACTURER. MATERIAL TO BE SUPPLIED BY THE CONTRACTOR. ALL COSTS ASSOCIATED WITH THE ABOVE WORK SHALL BE INCIDENTAL TO ITEM 604-70(22X10) PRECAST CONCRETE BOX CULVERT.

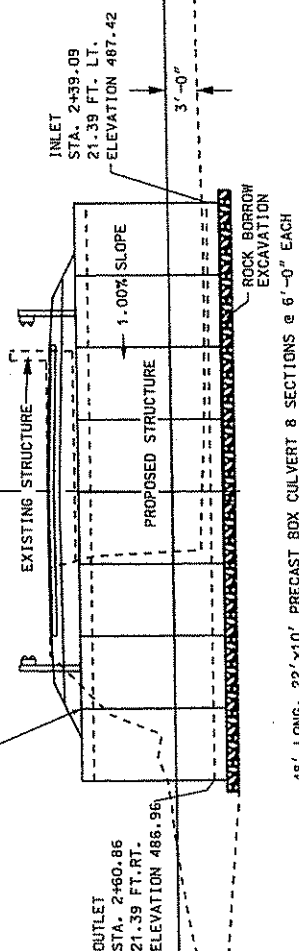

48' LONG, 22' X 10' PRECAST BOX CULVERT 8 SECTIONS @ 6'-0" EACH

CULVERT ELEVATION VIEW

NOTE: CULVERT IS SKEWED 27° RIGHT FORWARD.

CULVERT LAYOUT VIEW

DATE	BY	REVISION
02-07	MAK	DESIGN
02-07	MAK	REVISED
02-07	MAK	REVISED

SCALE	DATE	BY
1" = 10'	02-07	MAK

THE WEST VIRGINIA DEPARTMENT OF TRANSPORTATION
DIVISION OF HIGHWAYS
SUPERSTRUCTURE DETAILS
PICKENAW RUN BRIDGE

STATE PROJECT NUMBER	SECTION NUMBER	STATE NO.	COUNTY	SHEET NO.	TOTAL SHEETS
370-24-330	N/A		HERKULES	11	15

NOTE: ALL COST ASSOCIATED WITH THE GUARDRAIL ASSEMBLIES ARE TO BE INCLUDED IN THEIR RESPECTIVE TYPE GUARDRAIL CLASS 'V'.

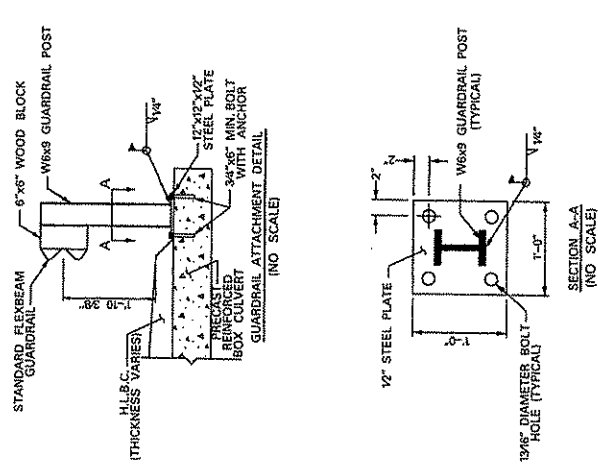

NOTE: AFTER THIS GUARDRAIL POST AND 12\"/>

GUARDRAIL QUANTITIES LIST

FOR INFORMATION ONLY

- 6 SECTIONS OF GUARDRAIL @ 20' RADIUS
- 1 SECTION OF GUARDRAIL @ 10' RADIUS
- 3 SECTIONS OF STRAIGHT GUARDRAIL
- 1 SECTION OF GUARDRAIL @ 10' RADIUS
- 4 GUARDRAIL END SECTIONS
- 4 GUARDRAIL END SECTIONS
- 18 GUARDRAIL POSTS (6'-0" LENGTHS)
- 8 GUARDRAIL POSTS MODIFIED WITH 12" X 12" X 1/2" STEEL PLATE ATTACHMENT ASSEMBLIES
- 26 WOODEN BLOCKS

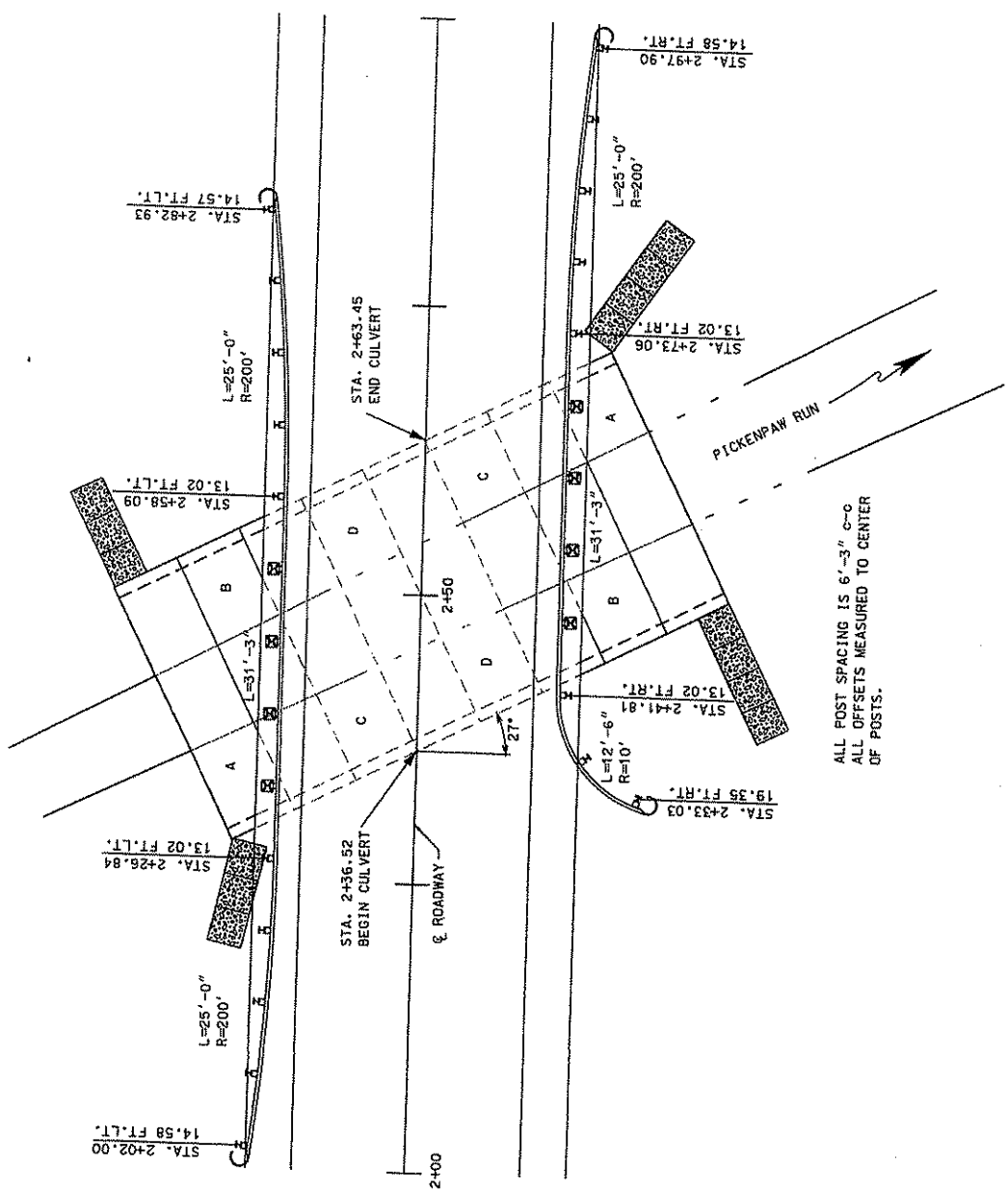

ALL POST SPACING IS 6'-3" C-C
ALL OFFSETS MEASURED TO CENTER OF POSTS.

GUARDRAIL LAYOUT

DATE	BY	REVISION
02-07		
02-07		
02-07		

SCALE	1" = 40'
-------	----------

THE WEST VIRGINIA DEPARTMENT OF TRANSPORTATION
DIVISION OF HIGHWAYS
GUARDRAIL LAYOUT AND DETAILS
PICKENPAW RUN BRIDGE

VENDOR PREFERENCE CERTIFICATE

Certification and application* is hereby made for Preference in accordance with *West Virginia Code*, §5A-3-37. (Does not apply to construction contracts). *West Virginia Code*, §5A-3-37, provides an opportunity for qualifying vendors to request (at the time of bid) preference for their residency status. Such preference is an evaluation method only and will be applied only to the cost bid in accordance with the *West Virginia Code*. This certificate for application is to be used to request such preference. The Purchasing Division will make the determination of the Resident Vendor Preference, if applicable.

- 1. **Application is made for 2.5% resident vendor preference for the reason checked:**
 Bidder is an individual resident vendor and has resided continuously in West Virginia for four (4) years immediately preceding the date of this certification; **or**,
 Bidder is a partnership, association or corporation resident vendor and has maintained its headquarters or principal place of business continuously in West Virginia for four (4) years immediately preceding the date of this certification; or 80% of the ownership interest of Bidder is held by another individual, partnership, association or corporation resident vendor who has maintained its headquarters or principal place of business continuously in West Virginia for four (4) years immediately preceding the date of this certification; **or**,
 Bidder is a nonresident vendor which has an affiliate or subsidiary which employs a minimum of one hundred state residents and which has maintained its headquarters or principal place of business within West Virginia continuously for the four (4) years immediately preceding the date of this certification; **or**,
- 2. **Application is made for 2.5% resident vendor preference for the reason checked:**
 Bidder is a resident vendor who certifies that, during the life of the contract, on average at least 75% of the employees working on the project being bid are residents of West Virginia who have resided in the state continuously for the two years immediately preceding submission of this bid; **or**,
- 3. **Application is made for 2.5% resident vendor preference for the reason checked:**
 Bidder is a nonresident vendor employing a minimum of one hundred state residents or is a nonresident vendor with an affiliate or subsidiary which maintains its headquarters or principal place of business within West Virginia employing a minimum of one hundred state residents who certifies that, during the life of the contract, on average at least 75% of the employees or Bidder's affiliate's or subsidiary's employees are residents of West Virginia who have resided in the state continuously for the two years immediately preceding submission of this bid; **or**,
- 4. **Application is made for 5% resident vendor preference for the reason checked:**
 Bidder meets either the requirement of both subdivisions (1) and (2) or subdivision (1) and (3) as stated above; **or**,
- 5. **Application is made for 3.5% resident vendor preference who is a veteran for the reason checked:**
 Bidder is an individual resident vendor who is a veteran of the United States armed forces, the reserves or the National Guard and has resided in West Virginia continuously for the four years immediately preceding the date on which the bid is submitted; **or**,
- 6. **Application is made for 3.5% resident vendor preference who is a veteran for the reason checked:**
 Bidder is a resident vendor who is a veteran of the United States armed forces, the reserves or the National Guard, if, for purposes of producing or distributing the commodities or completing the project which is the subject of the vendor's bid and continuously over the entire term of the project, on average at least seventy-five percent of the vendor's employees are residents of West Virginia who have resided in the state continuously for the two immediately preceding years.

Bidder understands if the Secretary of Revenue determines that a Bidder receiving preference has failed to continue to meet the requirements for such preference, the Secretary may order the Director of Purchasing to: (a) reject the bid; or (b) assess a penalty against such Bidder in an amount not to exceed 5% of the bid amount and that such penalty will be paid to the contracting agency or deducted from any unpaid balance on the contract or purchase order.

By submission of this certificate, Bidder agrees to disclose any reasonably requested information to the Purchasing Division and authorizes the Department of Revenue to disclose to the Director of Purchasing appropriate information verifying that Bidder has paid the required business taxes, provided that such information does not contain the amounts of taxes paid nor any other information deemed by the Tax Commissioner to be confidential.

Under penalty of law for false swearing (*West Virginia Code*, §61-5-3), Bidder hereby certifies that this certificate is true and accurate in all respects; and that if a contract is issued to Bidder and if anything contained within this certificate changes during the term of the contract, Bidder will notify the Purchasing Division in writing immediately.

Bidder: Carr Conchete

Signed: Robert "Burr" Stanley

Date: 1-20-09

Title: Project Manager

*Check any combination of preference consideration(s) indicated above, which you are entitled to receive.

STATE OF WEST VIRGINIA
Purchasing Division**PURCHASING AFFIDAVIT****VENDOR OWING A DEBT TO THE STATE:**

West Virginia Code §5A-3-10a provides that: No contract or renewal of any contract may be awarded by the state or any of its political subdivisions to any vendor or prospective vendor when the vendor or prospective vendor or a related party to the vendor or prospective vendor is a debtor and the debt owed is an amount greater than one thousand dollars in the aggregate.

PUBLIC IMPROVEMENT CONTRACTS & DRUG-FREE WORKPLACE ACT:

West Virginia Code §21-1D-5 provides that: Any solicitation for a public improvement construction contract shall require each vendor that submits a bid for the work to submit at the same time an affidavit that the vendor has a written plan for a drug-free workplace policy in compliance with Article 1D, Chapter 21 of the West Virginia Code. A public improvement construction contract may not be awarded to a vendor who does not have a written plan for a drug-free workplace policy in compliance with Article 1D, Chapter 21 of the West Virginia Code and who has not submitted that plan to the appropriate contracting authority in timely fashion. For a vendor who is a subcontractor, compliance with Section 5, Article 1D, Chapter 21 of the West Virginia Code may take place before their work on the public improvement is begun.

ANTITRUST:

In submitting a bid to any agency for the state of West Virginia, the bidder offers and agrees that if the bid is accepted the bidder will convey, sell, assign or transfer to the state of West Virginia all rights, title and interest in and to all causes of action it may now or hereafter acquire under the antitrust laws of the United States and the state of West Virginia for price fixing and/or unreasonable restraints of trade relating to the particular commodities or services purchased or acquired by the state of West Virginia. Such assignment shall be made and become effective at the time the purchasing agency tenders the initial payment to the bidder.

I certify that this bid is made without prior understanding, agreement, or connection with any corporation, firm, limited liability company, partnership or person or entity submitting a bid for the same materials, supplies, equipment or services and is in all respects fair and without collusion or fraud. I further certify that I am authorized to sign the certification on behalf of the bidder or this bid.

LICENSING:

Vendors must be licensed and in good standing in accordance with any and all state and local laws and requirements by any state or local agency of West Virginia, including, but not limited to, the West Virginia Secretary of State's Office, the West Virginia Tax Department, West Virginia Insurance Commission, or any other state agencies or political subdivision. Furthermore, the vendor must provide all necessary releases to obtain information to enable the Director or spending unit to verify that the vendor is licensed and in good standing with the above entities.

CONFIDENTIALITY:

The vendor agrees that he or she will not disclose to anyone, directly or indirectly, any such personally identifiable information or other confidential information gained from the agency, unless the individual who is the subject of the information consents to the disclosure in writing or the disclosure is made pursuant to the agency's policies, procedures and rules. Vendors should visit www.state.wv.us/admin/purchase/privacy for the Notice of Agency Confidentiality Policies.

Under penalty of law for false swearing (West Virginia Code §61-5-3), it is hereby certified that the vendor acknowledges the information in this said affidavit and is in compliance with the requirements as stated.

Vendor's Name: Carr Concrete Corporation

Authorized Signature: Robert "Burr" Standley Date: 1-20-09



State of West Virginia
 Department of Administration
 Purchasing Division
 2019 Washington Street East
 Post Office Box 50130
 Charleston, WV 25305-0130

Request for Quotation

RFQ NUMBER
 06900188

PAGE
 1

ADDRESS CORRESPONDENCE TO ATTENTION OF
 MICHAEL AUSTIN
 304-558-2402

*709055926 304-464-4441
 CARR CONCRETE CORPORATION
 PO BOX 265
 WAVERLY WV 26184-0265

DIVISION OF HIGHWAYS
 JOBSITE
 SEE SPECIFICATIONS

DATE PRINTED	TERMS OF SALE	SHIP VIA	F.O.B.	FREIGHT TERMS
12/19/2008				

BID OPENING DATE: 01/14/2009 BID OPENING TIME 01:30PM

LINE	QUANTITY	UOP	CAT. NO.	ITEM NUMBER	UNIT PRICE	AMOUNT
ADDENDUM #01						
BID OPENING DATE AND TIME CHANGE						
FROM: 01/07/2009						
TO: 01/14/2009						
NO OTHER CHANGES						
0001	48	LF	968-27	PRECAST BOX CULVERT 20' SPAN BY 10'RISE	\$ 1,734. ⁰⁰	\$ 83,232. ⁰⁰
***** THIS IS THE END OF RFQ 06900188 ***** TOTAL:						\$ 83,232. ⁰⁰

SEE REVERSE SIDE FOR TERMS AND CONDITIONS

SIGNATURE: *Robert "Bun" Stanley* TELEPHONE: 1-304-464-4441 DATE: 1-20-09

TITLE: Project Manager FEIN: 55-0685425 ADDRESS CHANGES TO BE NOTED ABOVE

WHEN RESPONDING TO RFQ, INSERT NAME AND ADDRESS IN SPACE ABOVE LABELED 'VENDOR'



State of West Virginia
 Department of Administration
 Purchasing Division
 2019 Washington Street East
 Post Office Box 50130
 Charleston, WV 25305-0130

Request for Quotation

RFQ NUMBER
 06900188

PAGE
 1

ADDRESS CORRESPONDENCE TO ATTENTION OF
 MICHAEL AUSTIN
 304-558-2402

VENDOR

*709055926 304-464-4441
 CARR CONCRETE CORPORATION
 PO BOX 265
 WAVERLY WV 26184-0265

SHIP TO

DIVISION OF HIGHWAYS
 JOBSITE
 SEE SPECIFICATIONS

RECEIVED
 JAN 13 2009

BY:

DATE PRINTED	TERMS OF SALE	SHIP VIA	F.O.B.	FREIGHT TERMS
01/12/2009				

BID OPENING DATE: 01/21/2009 BID OPENING TIME 01:30PM

LINE	QUANTITY	UOP	CAT NO	ITEM NUMBER	UNIT PRICE	AMOUNT
ADDENDUM NO. 2						
BID OPENING DATE AND TIME CHANGED						
FROM: 01/14/09 AT 1:30 P.M.						
TO: 01/21/09 AT 1:30 P.M.						
NO OTHER CHANGES						
0001	48	LF		968-27		
PRECAST BOX CULVERT 20' SPAN BY 10' RISE						
***** THIS IS THE END OF RFQ 06900188 ***** TOTAL: _____						

SEE REVERSE SIDE FOR TERMS AND CONDITIONS

SIGNATURE	TELEPHONE	DATE
<i>Project Manager</i>	1-304-46	1-20-09
TITLE	FEIN	ADDRESS CHANGES TO BE NOTED ABOVE
	55-0685425	

WHEN RESPONDING TO RFQ, INSERT NAME AND ADDRESS IN SPACE ABOVE LABELED 'VENDOR'