



State of West Virginia
 Department of Administration
 Purchasing Division
 2019 Washington Street East
 Post Office Box 50130
 Charleston, WV 25305-0130

Request for Quotation

RFQ NUMBER
DEP14241

PAGE
1

ADDRESS CORRESPONDENCE TO ATTENTION OF
CHUCK BOWMAN
304-558-2157

VENDOR
 *709060417 304-984-1115
CARPENTER RECLAMATION INC
PO BOX 13015

SISSONVILLE WV 25360-0015

SHIP TO
ENVIRONMENTAL PROTECTION
DEPARTMENT OF
OFFICE OF AML&R
601 57TH STREET SE
CHARLESTON, WV
25304 ~~304-926-0499~~

| DATE PRINTED | TERMS OF SALE | SHIP VIA | F.O.B. | FREIGHT TERMS |
|--------------|---------------|----------|--------|---------------|
| 01/16/2008 | | | | |

BID OPENING DATE: **02/28/2008** BID OPENING TIME: **01:30PM**

| LINE | QUANTITY | UOP | CAT. NO. | ITEM NUMBER | UNIT PRICE | AMOUNT |
|---|----------|-----|----------|-------------|------------|-------------------|
| 0001 | 1 | LS | | 962-73 | <i>1</i> | <i>134,800.00</i> |
| RECLAMATION: RESTORATION OF LAND & OTHER PROPERTIES THE WEST VIRGINIA PURCHASING DIVISION, FOR THE AGENCY, THE WV DEPARTMENT OF ENVIRONMENTAL PROTECTION, IS SOLICITING BIDS FROM QUALIFIED CONTRACTORS FOR A CONTRACT TO PROVIDE ALL LABOR AND MATERIALS FOR THE RECLAMATION OF 1/2-ACRE ABANDONED MINE PROJECT KNOWN A "WHITMAN (WILLIAMS) DRAINAGE" PROJECT. THE SITE IS LOCATED IN WHITMAN (LOGAN CO.), WV. A MANDATORY ON SITE PREBID CONFERENCE SHALL BE HELD ON 02/05/08 @ 1:30 PM. FAILURE TO ATTEND THE PREBID CONFERENCE WILL RESULT IN BID DISQUALIFICATION. ALSO, PREBIDS WILL INVOLVE EXTENSIVE FOOT TRAVEL OVER DIFFICULT TERRAIN AND/OR DURING INCLEMENT WEATHER. DIRECTIONS TO PREBID: FROM CHARLESTON, TAKE ROUTE 119 SOUTH APPROXIMATELY 55 MILES. TURN LEFT ON THE WHITMAN JUNCTION EXIT. AT STOP SIGN, TURN LEFT ON HOLDEN ROAD. TRAVEL 0.1 MILES AND TURN RIGHT ON WHITMAN CREEK ROAD (9/1). TRAVEL 0.9 MILES TO SOUTHERN WV ASPHALT AND TRI-STATE MINE SERVICE AND TURN LEFT ON CELESTIAL WAY. SITE IS BEHIND TRI STATE MINE SERVICE. PLANS AND SPECIFICATIONS MAY BE OBTAINED FROM WVDEP, OFFICE AML&R, 601 57TH ST., SE, CHARLESTON, WV 25304 PH. 304-926-0485 UPON PAYMENT OF \$10.00 NON-REFUNDABLE FEE. PAYMENT MUST BE MADE BY CHECK OR MONEY ORDER. | | | | | | |

RECEIVED
 2008 MAR -5 A 9:09
 PURCHASING DIVISION
 STATE OF WV

SEE REVERSE SIDE FOR TERMS AND CONDITIONS

SIGNATURE *Ke* TELEPHONE DATE *3/5/08*

TITLE FEIN ADDRESS CHANGES TO BE NOTED ABOVE

WHEN RESPONDING TO RFQ, INSERT NAME AND ADDRESS IN SPACE ABOVE LABELED 'VENDOR'



State of West Virginia
 Department of Administration
 Purchasing Division
 2019 Washington Street East
 Post Office Box 50130
 Charleston, WV 25305-0130

Request for Quotation

RFQ NUMBER:
 DEP14241

PAGE:
 2

ADDRESS CORRESPONDENCE TO ATTENTION OF:
 CHUCK BOWMAN
 304-558-2157

VENDOR
 *709060417 304-984-1115
 CARPENTER RECLAMATION INC
 PO BOX 13015
 SISSONVILLE WV 25360-0015

SHIP TO
 ENVIRONMENTAL PROTECTION
 DEPARTMENT OF
 OFFICE OF AML&R
 601 57TH STREET SE
 CHARLESTON, WV
 25304 304-926-0499

| | | | | |
|--------------|---------------|----------|-----|---------------|
| DATE PRINTED | TERMS OF SALE | SHIP VIA | FOB | FREIGHT TERMS |
| 01/16/2008 | | | | |

BID OPENING DATE: 02/28/2008 BID OPENING TIME 01:30PM

| LINE | QUANTITY | UOP | CAT. NO. | ITEM NUMBER | UNIT PRICE | AMOUNT |
|--|----------|-----|----------|-------------|------------|--------|
| <p>NO CASH WILL BE ACCEPTED.</p> <p>EXHIBIT 5</p> <p>NOTICE TO PROCEED: THIS CONTRACT IS TO BE PERFORMED WITHIN 365 CALENDAR DAYS AFTER THE NOTICE TO PROCEED IS RECEIVED. UNLESS OTHERWISE SPECIFIED, THE FULLY EXECUTED PURCHASE ORDER WILL BE CONSIDERED NOTICE TO PROCEED.</p> <p>CANCELLATION: THE DIRECTOR OF PURCHASING RESERVES THE RIGHT TO CANCEL THIS CONTRACT IMMEDIATELY UPON WRITTEN NOTICE TO THE VENDOR IF THE MATERIALS OR WORKMANSHIP SUPPLIED ARE OF AN INFERIOR QUALITY OR DO NOT CONFORM WITH THE SPECIFICATIONS OF THE THE BID AND CONTRACT HEREIN.</p> <p>WAGE RATES: THE CONTRACTOR OR SUBCONTRACTOR SHALL PAY THE HIGHER OF THE U.S. DEPARTMENT OF LABOR MINIMUM WAGE RATES AS ESTABLISHED FOR LOGAN COUNTY, PURSUANT TO WEST VIRGINIA CODE 21-5A, ET,SEQ.</p> <p>ARBITRATION: ANY REFERENCES MADE TO ARBITRATION OR INTEREST FOR PAYMENTS DUE (EXCEPT FOR ANY INTEREST REQUIRED BY STATE LAW) CONTAINED IN THIS CONTRACT OR IN ANY AMERICAN INSTITUTE OF ARCHITECTS DOCUMENTS PERTAINING TO THIS CONTRACT ARE HEREBY DELETED.</p> <p>WORKERS' COMPENSATION: VENDOR IS REQUIRED TO PROVIDE A CERTIFICATE FROM WORKERS' COMPENSATION IF SUCCESSFUL.</p> <p>ALL OF THE ITEMS CHECKED BELOW WILL BE A REQUIREMENT OF THIS CONTRACT:</p> <p>(XX) INSURANCE: SUCCESSFUL VENDOR SHALL FURNISH PROOF</p> | | | | | | |

SEE REVERSE SIDE FOR TERMS AND CONDITIONS

| | | |
|------------------------|-----------|-----------------------------------|
| SIGNATURE <i>KC</i> | TELEPHONE | DATE <i>3/5/08</i> |
| TITLE | FEIN | ADDRESS CHANGES TO BE NOTED ABOVE |

WHEN RESPONDING TO RFQ, INSERT NAME AND ADDRESS IN SPACE ABOVE LABELED 'VENDOR'



State of West Virginia
 Department of Administration
 Purchasing Division
 2019 Washington Street East
 Post Office Box 50130
 Charleston, WV 25305-0130

Request for Quotation

RFQ NUMBER
DEP14241

PAGE
3

ADDRESS CORRESPONDENCE TO ATTENTION OF
CHUCK BOWMAN
304-558-2157

VENDOR

*709060417 304-984-1115
 CARPENTER RECLAMATION INC
 PO BOX 13015
 SISSONVILLE WV 25360-0015

SHIP TO

ENVIRONMENTAL PROTECTION
 DEPARTMENT OF
 OFFICE OF AML&R
 601 57TH STREET SE
 CHARLESTON, WV
 25304 304-926-0499

| DATE PRINTED | TERMS OF SALE | SHIP VIA | F.O.B. | FREIGHT TERMS |
|--------------|---------------|----------|--------|---------------|
| 01/16/2008 | | | | |

BID OPENING DATE: **02/28/2008** BID OPENING TIME **01:30PM**

| LINE | QUANTITY | UOP | CAT. NO. | ITEM NUMBER | UNIT PRICE | AMOUNT |
|------|----------|-----|----------|--|------------|--------|
| | | | | <p>OF COMMERCIAL GENERAL LIABILITY INSURANCE PRIOR TO ISSUANCE OF CONTRACT. UNLESS OTHERWISE SPECIFIED IN THE BID DOCUMENTS, THE MINIMUM AMOUNT OF INSURANCE COVERAGE REQUIRED IS \$250,000.</p> <p>() BUILDERS RISK INSURANCE: SUCCESSFUL VENDOR SHALL FURNISH PROOF OF BUILDERS RISK - ALL RISK INSURANCE IN AN AMOUNT EQUAL TO 100% OF THE AMOUNT OF THE CONTRACT.</p> <p>(XX) BONDS: FIVE PERCENT (5%) OF THE TOTAL AMOUNT OF THE BID PAYABLE TO THE STATE OF WEST VIRGINIA, SHALL BE SUBMITTED WITH EACH BID AS A BID BOND. THE SUCCESSFUL BIDDER SHALL ALSO FURNISH A PERFORMANCE BOND AND LABOR/MATERIAL BOND FOR 100% OF THE AMOUNT OF THE CONTRACT. BONDS MAY BE PROVIDED IN THE FORM OF A CERTIFIED CHECK, IRREVOCABLE LETTER OF CREDIT, OR BOND FURNISHED BY A SOLVENT SURETY COMPANY AUTHORIZED TO DO BUSINESS IN THE STATE OF WEST VIRGINIA. A LETTER OF CREDIT SUBMITTED IN LIEU OF A PERFORMANCE AND LABOR & MATERIAL BOND WILL ONLY BE ALLOWED FOR PROJECTS UNDER \$100,000. PERSONAL OR BUSINESS CHECKS ARE NOT ACCEPTABLE IN LIEU OF THE 5% BID BOND, PERFORMANCE BOND, OR LABOR/MATERIAL BOND.</p> <p>() MAINTENANCE BOND: A TWO (2) YEAR MAINTENANCE BOND COVERING THE ROOFING SYSTEM WILL BE A REQUIREMENT OF THE SUCCESSFUL VENDOR.</p> <p>***** EXHIBIT 12</p> <p>AML CONTRACTOR INFORMATION FORM OMB #1029-0119 (EXPIRATION DATE: 01/31/2010) IS ATTACHED. YOU MUST COMPLETE THIS ORIGINAL FORM TO OBTAIN AN AVS DATA EVALUATION TO DETERMINE YOUR ELIGIBILITY AS AN AML CONTRACTOR. THIS IS A REQUIREMENT UNDER 30 CFR 874.16. IF THE ORIGINAL OMB #1029-0119 IS NOT ATTACHED TO THE</p> | | |

SEE REVERSE SIDE FOR TERMS AND CONDITIONS

SIGNATURE **Kc** TELEPHONE DATE **3/5/08**

TITLE FEIN ADDRESS CHANGES TO BE NOTED ABOVE

WHEN RESPONDING TO RFQ, INSERT NAME AND ADDRESS IN SPACE ABOVE LABELED 'VENDOR'



State of West Virginia
 Department of Administration
 Purchasing Division
 2019 Washington Street East
 Post Office Box 50130
 Charleston, WV 25305-0130

Request for Quotation

RFQ NUMBER
 DEP14241

PAGE
 4

ADDRESS CORRESPONDENCE TO ATTENTION OF:
 CHUCK BOWMAN
 304-558-2157

VENDOR

*709060417 304-984-1115
 CARPENTER RECLAMATION INC
 PO BOX 13015
 SISSONVILLE WV 25360-0015

SHIP TO

ENVIRONMENTAL PROTECTION
 DEPARTMENT OF
 OFFICE OF AML&R
 601 57TH STREET SE
 CHARLESTON, WV
 25304 304-926-0499

| DATE PRINTED | TERMS OF SALE | SHIP VIA | F.O.B. | FREIGHT TERMS |
|--------------|---------------|----------|--------|---------------|
| 01/16/2008 | | | | |

BID OPENING DATE: **02/28/2008** BID OPENING TIME **01:30PM**

| LINE | QUANTITY | UOP | CAT NO. | ITEM NUMBER | UNIT PRICE | AMOUNT |
|------|----------|-----|---------|--|------------|--------|
| | | | | <p>BIDDING DOCUMENTS YOU CAN CONTACT THE AVS OFFICE AT 800-643-9748 OR WWW.AVS.OSMRE.GOV *****</p> <p>CONTRACTORS LICENSE</p> <p>WEST VIRGINIA STATE CODE 21-11-2 REQUIRES THAT ALL PERSONS DESIRING TO PERFORM CONTRACTING WORK IN THIS STATE MUST BE LICENSED. THE WEST VIRGINIA CONTRACTORS LICENSING BOARD IS EMPOWERED TO ISSUE THE CONTRACTORS LICENSE. APPLICATIONS FOR A CONTRACTORS LICENSE MAY BE MADE BY CONTACTING THE WEST VIRGINIA DIVISION OF LABOR, CAPITOL COMPLEX, BUILDING 3, ROOM 319, CHARLESTON, WV 25305 OR PHONE 304-558-7890.</p> <p>WEST VIRGINIA STATE CODE 21-11-11 REQUIRES ANY PROSPECTIVE BIDDER TO INCLUDE THE CONTRACTORS LICENSE NUMBER ON THEIR BID. BIDDER TO COMPLETE:</p> <p>CONTRACTORS NAME:..... <i>Carpenter Reclamation Inc.</i></p> <p>CONTRACTORS LICENSE #:..... <i>315108</i>.....</p> <p>THE SUCCESSFUL BIDDER WILL BE REQUIRED TO FURNISH A COPY OF THEIR CONTRACTORS LICENSE PRIOR TO ISSUANCE OF A PURCHASE ORDER/CONTRACT.</p> <p>APPLICABLE LAW</p> <p>THE WEST VIRGINIA STATE CODE, PURCHASING DIVISION RULES & REGULATIONS, PURCHASING DIVISION POLICY STATEMENTS, AND THE INFORMATION PROVIDED IN THE "REQUEST FOR QUOTATION" ISSUED BY THE PURCHASING DIVISION IS THE SOLE AUTHORITY GOVERNING THIS PROCUREMENT.</p> | | |

SEE REVERSE SIDE FOR TERMS AND CONDITIONS

| | | |
|------------------------|-----------|-----------------------------------|
| SIGNATURE <i>KC</i> | TELEPHONE | DATE <i>3/5/08</i> |
| TITLE | FEIN | ADDRESS CHANGES TO BE NOTED ABOVE |

WHEN RESPONDING TO RFQ, INSERT NAME AND ADDRESS IN SPACE ABOVE LABELED 'VENDOR'



State of West Virginia
 Department of Administration
 Purchasing Division
 2019 Washington Street East
 Post Office Box 50130
 Charleston, WV 25305-0130

Request for Quotation

RFQ NUMBER
 DEP14241

PAGE
 5

ADDRESS CORRESPONDENCE TO ATTENTION OF:
 CHUCK BOWMAN
 304-558-2157

VENDOR

*709060417 304-984-1115
 CARPENTER RECLAMATION INC
 PO BOX 13015

 SISSONVILLE WV 25360-0015

SHIP TO

ENVIRONMENTAL PROTECTION
 DEPARTMENT OF
 OFFICE OF AML&R
 601 57TH STREET SE
 CHARLESTON, WV
 25304 304-926-0499

| | | | | |
|--|---------------|----------|--------|---------------|
| DATE PRINTED 01/16/2008 | TERMS OF SALE | SHIP VIA | F.O.B. | FREIGHT TERMS |
| BID OPENING DATE: 02/28/2008 BID OPENING TIME 01:30PM | | | | |

| LINE | QUANTITY | UOP | CAT. NO. | ITEM NUMBER | UNIT PRICE | AMOUNT |
|---|----------|-----|----------|-------------|------------|--------|
| <p>ANY INFORMATION PROVIDED IN SPECIFICATION MANUALS, OR ANY OTHER SOURCE, VERBAL OR WRITTEN, WHICH CONTRADICTS OR ALTERS THE INFORMATION PROVIDED FROM THE SOURCES AS DESCRIBED IN THE ABOVE PARAGRAPH IS VOID AND OF NO EFFECT.</p> <p>(1) NOTICE TO PROCEED: THE CONSTRUCTION WORK SPECIFIED HEREIN IS TO BE COMPLETED WITHIN 365 CALENDAR DAYS AFTER THE OFFICIAL NOTICE TO PROCEED IS RECEIVED. IN THE EVENT THAT A PRE-CONSTRUCTION CONFERENCE IS REQUIRED, THE NOTICE TO PROCEED SHALL BE THE SPECIFIC DATE ESTABLISHED IN THE PRE-CONSTRUCTION CONFERENCE.</p> <p>(2) GUARANTEE AND MAINTENANCE: (A) THE MATERIALS AND WORKMANSHIP AFFECTED BY THE CONTRACTOR ARE SUBJECT TO THE GUARANTEE ESTABLISHED BY CUSTOM OF THE RESPECTIVE TRADES. IN THE ABSENCE OF A TRADE GUARANTEE CUSTOM OR A SPECIAL GUARANTEE PROVISION, THE WORK, BOTH AS TO THE MATERIALS AND WORKMANSHIP, SHALL UPON ACCEPTANCE OF FINAL PAYMENT BY THE CONTRACTOR BE CONSIDERED GUARANTEED BY THE CONTRACTOR FOR ONE YEAR FROM THE DATE OF THE ACCEPTANCE OF THE WORK. NEITHER THE FINAL ACCEPTANCE NOR THE FINAL PAYMENT SHALL RELIEVE THE CONTRACTOR OF RESPONSIBILITY FOR NEGLIGENCE OR FAULTY MATERIALS, AND FOR DEFECTS APPEARING WITHIN THE GUARANTEE PERIOD SHALL BE REMEDIATED AT THE EXPENSE OF THE CONTRACTOR UPON WRITTEN NOTICE. (B) DURING THE ONE-YEAR GUARANTEE PERIOD, THE CONTRACTOR WILL MAINTAIN THE PROJECT TO THE CONDITIONS EXISTING AT THE DATE OF THE ACCEPTANCE OF THE WORK. ANY FAILURES DUE TO THE NEGLIGENCE OR WORKMANSHIP OF CONTRACTOR IN ANY OF THE WORK THAT DEVELOPS DURING THE GUARANTEE PERIOD SHALL BE CORRECTED BY THE CONTRACTOR</p> | | | | | | |

SEE REVERSE SIDE FOR TERMS AND CONDITIONS

| | | |
|------------------------|-----------|-----------------------------------|
| SIGNATURE <i>Kc</i> | TELEPHONE | DATE 3/5/08 |
| TITLE | FEIN | ADDRESS CHANGES TO BE NOTED ABOVE |

WHEN RESPONDING TO RFQ, INSERT NAME AND ADDRESS IN SPACE ABOVE LABELED 'VENDOR'



State of West Virginia
 Department of Administration
 Purchasing Division
 2019 Washington Street East
 Post Office Box 50130
 Charleston, WV 25305-0130

Request for Quotation

RFO NUMBER
 DEP14241

PAGE
 6

ADDRESS CORRESPONDENCE TO ATTENTION OF:
 CHUCK BOWMAN
 304-558-2157

VENDOR

*709060417 304-984-1115
 CARPENTER RECLAMATION INC
 PO BOX 13015
 SISSONVILLE WV 25360-0015

SHIP TO

ENVIRONMENTAL PROTECTION
 DEPARTMENT OF
 OFFICE OF AML&R
 601 57TH STREET SE
 CHARLESTON, WV
 25304 304-926-0499

| DATE PRINTED | TERMS OF SALE | SHIP VIA | F.O.B. | FREIGHT TERMS |
|--------------|---------------|----------|--------|---------------|
| 01/16/2008 | | | | |

BID OPENING DATE: **02/28/2008** BID OPENING TIME **01:30PM**

| LINE | QUANTITY | UOP | CAT NO. | ITEM NUMBER | UNIT PRICE | AMOUNT |
|--|----------|-----|---------|-------------|------------|--------|
| | | | | | | |
| <p>AT ITS EXPENSE.</p> <p>(C) THE ONE-YEAR GUARANTEE PERIOD SHALL NOT BE CONSTRUED AS BEING AN EXTENSION OF THE PERFORMANCE TIME ALLOTTED FOR WORK UNDER THE CONTRACT.</p> <p>(D) GUARANTEES CONCERNING REVEGETATION MAY BE FURTHER DEFINED IN THE TECHNICAL SPECIFICATIONS CONTAINED HEREIN.</p> <p>(3) TERMINATION:</p> <p>(1) THIS CONTRACT MAY BE CANCELLED IN WHOLE OR IN PART IN WRITING BY THE DIRECTOR OF PURCHASING, WITHOUT PREJUDICE TO ANY OTHER RIGHT OR REMEDY IT MAY HAVE, PROVIDED THAT THE CONTRACTOR IS GIVEN NOT LESS THAN THIRTY CALENDAR DAYS WRITTEN NOTICE, (DELIVERED BY CERTIFIED MAIL, RETURN RECEIPT REQUESTED) OF INTENT TO TERMINATE.</p> <p>(4) IT SHALL BE THE RESPONSIBILITY OF THE SUCCESSFUL VENDOR TO:</p> <p>(A) OBTAIN ALL NECESSARY DIVISION OF HIGHWAYS PERMITS FOR ALL TRANSPORTATION OF EQUIPMENT AND MATERIALS TO AND FROM THE JOB SITE.</p> <p>(B) OBTAIN ANY AND ALL REQUIRED CONSTRUCTION PERMITS OR RELATED JOB PERMITS.</p> <p>(5) TECHNICAL SPECIFICATIONS:</p> <p>ALL WORK UNDER THIS CONTRACT SHALL BE IN ACCORDANCE WITH THE SPECIFICATIONS PREPARED FOR THE RECLAMATION OF THE "WHITMAN (WILLIAMS) DRAINAGE" PROJECT. SAID PLANS & SPECS ARE INCORPORATED HERE IN BY REFERENCE AND ALL PROVISIONS, CLAUSES AND CONDITIONS THEREIN ARE MADE PROPERLY A PART OF THIS CONTRACT, AND CONSISTS OF 5 DRAWINGS AS PREPARED IN-HOUSE BY THE WEST VIRGINIA DEPARMENT OF ENVIRONMENTAL PROTECTION.</p> <p>(6) PAYMENTS AND COMPLETION:</p> | | | | | | |

SEE REVERSE SIDE FOR TERMS AND CONDITIONS

| | | |
|------------------------|-----------|-----------------------------------|
| SIGNATURE <i>KC</i> | TELEPHONE | DATE 3/5/08 |
| TITLE | FEIN | ADDRESS CHANGES TO BE NOTED ABOVE |

WHEN RESPONDING TO RFQ, INSERT NAME AND ADDRESS IN SPACE ABOVE LABELED 'VENDOR'



State of West Virginia
 Department of Administration
 Purchasing Division
 2019 Washington Street East
 Post Office Box 50130
 Charleston, WV 25305-0130

Request for Quotation

RFQ NUMBER
 DEP14241

PAGE
 7

ADDRESS CORRESPONDENCE TO ATTENTION OF
 CHUCK BOWMAN
 304-558-2157

VENDOR

*709060417 304-984-1115
 CARPENTER RECLAMATION INC
 PO BOX 13015
 SISSONVILLE WV 25360-0015

SHIP TO

ENVIRONMENTAL PROTECTION
 DEPARTMENT OF
 OFFICE OF AML&R
 601 57TH STREET SE
 CHARLESTON, WV
 25304 304-926-0499

| DATE PRINTED | TERMS OF SALE | SHIP VIA | F.O.B. | FREIGHT TERMS |
|--------------|---------------|----------|--------|---------------|
| 01/16/2008 | | | | |

BID OPENING DATE: 02/28/2008 BID OPENING TIME 01:30PM

| LINE | QUANTITY | UOP | CAT NO. | ITEM NUMBER | UNIT PRICE | AMOUNT |
|---|----------|-----|---------|-------------|------------|--------|
| <p>THE CONTRACTOR SHALL FURNISH TO DEP AN APPLICATION FOR PAYMENT WITH AN ITEMIZED SCHEDULE OF VALUES AS HEREIN BEFORE REQUESTED. THE FORM INCLUDED IN THE SPECIFICATIONS SHALL BE USED FOR APPLICATIONS OF PAYMENT. IT IS THE DEP'S INTENT THAT THE PAYMENT TO THE CONTRACTOR BE MADE WITHIN 60 DAYS AFTER RECEIPT OF APPLICATION FOR PAYMENT.</p> <p>(7) APPLICATION FOR PARTIAL PAYMENT: THE CONTRACTOR MAY, ON A PERIODIC BASIS, SUBMIT FOR PARTIAL PAYMENT BASED ON THE AMOUNT OF WORK COMPLETED AT THE TIME OF THE SUBMITTAL. THE AMOUNT OF PAYMENT WILL BE DETERMINED FROM THE ACTUAL QUANTITY OF WORK COMPLETED IF BASED UPON UNIT MEASURES OR THE PERCENT COMPLETED IF BASED UPON A LUMP SUM.</p> <p>BANKRUPTCY: IN THE EVENT THE VENDOR/CONTRACTOR FILES FOR BANKRUPTCY PROTECTION, THIS CONTRACT IS AUTOMATICALLY NULL AND VOID, AND IS TERMINATED WITHOUT FURTHER ORDER.</p> <p>REV. 9/98</p> <p>PREFERENCE FOR USE OF DOMESTIC STEEL PRODUCTS</p> <p>1. EXCEPT WHEN AUTHORIZED BY THE DIRECTOR OF THE PURCHASING DIVISION PURSUANT TO SUBSECTION 2 BELOW, NO CONTRACTOR MAY USE OR SUPPLY STEEL PRODUCTS FOR A STATE CONTRACT PROJECT OTHER THAN THOSE STEEL PRODUCTS MADE IN THE UNITED STATES. AS USED USED I THIS CONTRACT,</p> <p>A. "STATE CONTRACT PROJECT" MEANS ANY ERECTION OR CONSTRUCTION OF, OR ANY ADDITION TO, ALTERATION OF OR OTHER IMPROVEMENT TO ANY BUILDING OR STRUCTURE, INCLUDING, BUT NOT LIMITED TO, ROAD</p> | | | | | | |

SEE REVERSE SIDE FOR TERMS AND CONDITIONS

| | | |
|------------------------|-----------|-----------------------------------|
| SIGNATURE <i>Kc</i> | TELEPHONE | DATE 3/5/08 |
| TITLE | FEIN | ADDRESS CHANGES TO BE NOTED ABOVE |

WHEN RESPONDING TO RFQ, INSERT NAME AND ADDRESS IN SPACE ABOVE LABELED 'VENDOR'



State of West Virginia
 Department of Administration
 Purchasing Division
 2019 Washington Street East
 Post Office Box 50130
 Charleston, WV 25305-0130

Request for Quotation

RFQ NUMBER
 DEP14241

PAGE
 8

ADDRESS CORRESPONDENCE TO ATTENTION OF:
 CHUCK BOWMAN
 304-558-2157

VENDOR
 *709060417 304-984-1115
 CARPENTER RECLAMATION INC
 PO BOX 13015
 SISSONVILLE WV 25360-0015

SHIP TO
 ENVIRONMENTAL PROTECTION
 DEPARTMENT OF
 OFFICE OF AML&R
 601 57TH STREET SE
 CHARLESTON, WV
 25304 304-926-0499

| DATE PRINTED | TERMS OF SALE | SHIP VIA | F.O.B. | FREIGHT TERMS |
|------------------------------|---------------|--------------------------|--------|---------------|
| 01/16/2008 | | | | |
| BID OPENING DATE: 02/28/2008 | | BID OPENING TIME 01:30PM | | |

| LINE | QUANTITY | UOP | CAT. NO. | ITEM NUMBER | UNIT PRICE | AMOUNT |
|------|----------|-----|----------|---|------------|--------|
| | | | | | | |
| | | | | <p>OR HIGHWAYS, OR THE INSTALLATION OF ANY HEATING OR COOLING OR VENTILATING PLANTS OR OTHER EQUIPMENT, OR THE SUPPLY OF AND MATERIALS FOR SUCH PROJECTS, PURSUANT TO A CONTRACT WITH THE STATE OF WEST VIRGINIA FOR WHICH BIDS WERE SOLICITED ON OR AFTER JUNE 6, 2001.</p> <p>B. "STEEL PRODUCTS" MEANS PRODUCTS ROLLED, FORMED, SHAPED, DRAWN, EXTRUDED, FORGED, CAST, FABRICATED OR OTHERWISE SIMILARLY PROCESSED, OR PROCESSED BY A COMBINATION OF TWO OR MORE OF SUCH OPERATIONS, FROM STEEL MADE BY THE OPEN HEARTH, BASIC OXYGEN, ELECTRIC FURNACE, BESSEMER OR OTHER STEEL MAKING PROCESS.</p> <p>C. "UNITED STATES" MEANS THE UNITED STATES OF AMERICA AND INCLUDES ALL TERRITORY, CONTINENTAL OR INSULAR, SUBJECT TO THE JURISDICTION OF THE UNITED STATES.</p> <p>2. THE DIRECTOR OF THE PURCHASING DEPARTMENT MAY, IN WRITING, AUTHORIZE THE USE OF FOREIGN STEEL PRODUCTS IF:</p> <p>A. THE COST FOR EACH CONTRACT ITEM USED DOES NOT EXCEED ONE TENTH OF ONE PERCENT (.1%) OF THE TOTAL CONTRACT COST OR TWO THOUSAND FIVE HUNDRED DOLLARS (\$2,500.00), WHICHEVER IS GREATER. FOR THE PURPOSES OF THIS SECTION, THE COST IS THE VALUE OF THE STEEL PRODUCT AS DELIVERED TO THE PROJECT OR,</p> <p>B. THE DIRECTOR OF THE PURCHASING DIVISION DETERMINES THAT SPECIFIED STEEL MATERIALS ARE NOT PRODUCED IN THE UNITED STATES IN SUFFICIENT QUANTITY OR OTHERWISE ARE NOT REASONABLY</p> | | |

SEE REVERSE SIDE FOR TERMS AND CONDITIONS

SIGNATURE: *RC* TELEPHONE: DATE: *3/5/08*

TITLE: FEIN: ADDRESS CHANGES TO BE NOTED ABOVE

WHEN RESPONDING TO RFQ, INSERT NAME AND ADDRESS IN SPACE ABOVE LABELED 'VENDOR'



State of West Virginia
 Department of Administration
 Purchasing Division
 2019 Washington Street East
 Post Office Box 50130
 Charleston, WV 25305-0130

Request for Quotation

RFQ NUMBER
 DEP14241

PAGE
 9

ADDRESS CORRESPONDENCE TO ATTENTION OF:
 CHUCK BOWMAN
 304-558-2157

VENDOR

*709060417 304-984-1115
 CARPENTER RECLAMATION INC
 PO BOX 13015
 SISSONVILLE WV 25360-0015

SHIP TO

ENVIRONMENTAL PROTECTION
 DEPARTMENT OF
 OFFICE OF AML&R
 601 57TH STREET SE
 CHARLESTON, WV
 25304 304-926-0499

| DATE PRINTED | TERMS OF SALE | SHIP VIA | F.O.B. | FREIGHT TERMS |
|--------------|---------------|----------|--------|---------------|
| 01/16/2008 | | | | |

BID OPENING DATE: 02/28/2008 BID OPENING TIME 01:30PM

| LINE | QUANTITY | UOP | CAT NO | ITEM NUMBER | UNIT PRICE | AMOUNT |
|--|----------|-----|--------|-------------|------------|--------|
| <p>AVAILABLE TO MEET CONTRACT REQUIREMENTS.</p> <p>3. A CONTRACTOR WHO USES STEEL PRODUCTS IN VIOLATION OF THIS SECTION MAY BE SUBJECT TO CIVIL PENALTIES PURSUANT TO W. VA. CODE SECTION 5A-3-56.</p> <p>REV. 10/01/01</p> <p>EXHIBIT 7</p> <p>DOMESTIC ALUMINUM, GLASS & STEEL IN PUBLIC WORKS PROJECTS</p> <p>IN ACCORDANCE WITH WEST VIRGINIA CODE 5-19-1 ET., SEQ., EVERY CONTRACT FOR CONSTRUCTION, RECONSTRUCTION, ALTERATION, REPAIR, IMPROVEMENT OR MAINTENANCE OF PUBLIC WORKS, WHERE THE COST IS MORE THAN \$50,000 AND, IN THE CASE OF STEEL ONLY, WHERE THE COST OF STEEL IS MORE THAN \$50,000 OR WHERE MORE THAN 10,000 POUNDS OF STEEL ARE REQUIRED, THE STATE WILL ACCEPT ONLY ALUMINUM GLASS, OR STEEL PRODUCTS PRODUCED IN THE UNITED STATES. IN ADDITION, ITEMS OF MACHINERY OR EQUIPMENT PURCHASED FOR USE AT THE SITE OF PUBLIC WORKS SHALL BE MADE OF DOMESTIC ALUMINUM, GLASS OR STEEL, UNLESS THE COST OF THE PRODUCT IS LESS THAN \$50,000 OR LESS THAN 10,000 POUNDS OF STEEL ARE USED IN PUBLIC WORKS PROJECTS.</p> <p>FOREIGN MADE ALUMINUM, GLASS OR STEEL PRODUCTS MAY BE ACCEPTED ONLY IF THE COST OF DOMESTIC PRODUCTS IS FOUND TO BE UNREASONABLE. SUCH COST IS UNREASONABLE IF IT IS 20% OR MORE HIGHER THAN THE BID PRICE FOR FOREIGN MADE PRODUCTS. IF THE DOMESTIC ALUMINUM, GLASS OR STEEL PRODUCTS TO BE SUPPLIED OR PRODUCED IN A "SUBSTANTIAL LABOR SURPLUS AREA", AS DEFINED BY THE UNITED STATES DEPARTMENT OF LABOR, FOREIGN PRODUCTS MAY BE SUPPLIED ONLY IF DOMESTIC PRODUCTS ARE 30% OR MORE HIGHER IN</p> | | | | | | |

SEE REVERSE SIDE FOR TERMS AND CONDITIONS

| | | |
|------------------------|-----------|-----------------------------------|
| SIGNATURE <i>KC</i> | TELEPHONE | DATE 3/5/08 |
| TITLE | FEIN | ADDRESS CHANGES TO BE NOTED ABOVE |

WHEN RESPONDING TO RFQ, INSERT NAME AND ADDRESS IN SPACE ABOVE LABELED 'VENDOR'



State of West Virginia
 Department of Administration
 Purchasing Division
 2019 Washington Street East
 Post Office Box 50130
 Charleston, WV 25305-0130

Request for Quotation

RFQ NUMBER
 DEP14241

PAGE
 10

ADDRESS CORRESPONDENCE TO ATTENTION OF:
 CHUCK BOWMAN
 304-558-2157

VENDOR

*709060417 304-984-1115
 CARPENTER RECLAMATION INC
 PO BOX 13015
 SISSONVILLE WV 25360-0015

SHIP TO

ENVIRONMENTAL PROTECTION
 DEPARTMENT OF
 OFFICE OF AML&R
 601 57TH STREET SE
 CHARLESTON, WV
 25304 304-926-0499

| DATE PRINTED | TERMS OF SALE | SHIP VIA | F.O.B. | FREIGHT TERMS |
|--------------|---------------|----------|--------|---------------|
| 01/16/2008 | | | | |

BID OPENING DATE: 02/28/2008 BID OPENING TIME 01:30PM

| LINE | QUANTITY | UOP | CAT NO. | ITEM NUMBER | UNIT PRICE | AMOUNT |
|--|----------|-----|---------|-------------|------------|--------|
| | | | | | | |
| <p>PRICE THAN THE FOREIGN MADE PRODUCTS.</p> <p>IF, PRIOR TO THE AWARD OF A CONTRACT UNDER THE ABOVE PROVISIONS, THE SPENDING OFFICER OF THE SPENDING UNIT DETERMINES THAT THERE EXISTS A BID FOR LIKE FOREIGN ALUMINUM, GLASS OR STEEL THAT IS REASONABLE AND LOWER THAN THE LOWEST BID FOR DOMESTIC PRODUCTS, THE SPENDING OFFICE MAY REQUEST, IN WRITING, A REEVALUATION AND REDUCTION IN THE LOWEST BID FOR SUCH DOMESTIC PRODUCTS. ALL VENDORS MUST INDICATE IN THEIR BID IF THEY ARE SUPPLYING FOREIGN ALUMINUM, GLASS OR STEEL.</p> <p>REV. 3/88</p> <p>EXHIBIT 9</p> <p>NOTICE FOR ISSUANCE & ACKNOWLEDGEMENT OF CONSTRUCTION PROJECT ADDENDA</p> <p>THE ARCHITECT/ENGINEER AND/OR AGENCY SHALL BE REQUIRED TO ABIDE BY THE FOLLOWING SCHEDULE IN ISSUING CONSTRUCTION PROJECT ADDENDA FOR STATE AGENCIES:</p> <p>(1) THE ARCHITECT/ENGINEER SHALL PREPARE THE ADDENDUM AND A LIST OF ALL PARTIES THAT HAVE PROCURED DRAWINGS AND SPECIFICATIONS FOR THE PROJECT. THE ADDENDUM AND AND LIST SHALL BE FORWARDED TO THE BUYER IN THE STATE PURCHASING DIVISION. THE ARCHITECT/ENGINEER SHALL ALSO SEND A COPY OF THE ADDENDUM TO THE STATE AGENCY FOR WHICH THE CONTRACT IS ISSUED.</p> <p>(2) THE BUYER SHALL SEND THE ADDENDUM TO ALL INTERESTED PARTIES AND, IF NECESSARY, EXTEND THE BID OPENING DATE. ANY ADDENDUM SHOULD BE RECEIVED BY THE BUYER WITHIN FOURTEEN (14) DAYS PRIOR TO THE BID</p> | | | | | | |

SEE REVERSE SIDE FOR TERMS AND CONDITIONS

| | | |
|------------------------|-----------|-----------------------------------|
| SIGNATURE <i>KC</i> | TELEPHONE | DATE 3/5/08 |
| TITLE | FEIN | ADDRESS CHANGES TO BE NOTED ABOVE |

WHEN RESPONDING TO RFQ, INSERT NAME AND ADDRESS IN SPACE ABOVE LABELED 'VENDOR'



State of West Virginia
 Department of Administration
 Purchasing Division
 2019 Washington Street East
 Post Office Box 50130
 Charleston, WV 25305-0130

Request for Quotation

RFQ NUMBER
DEP14241

PAGE
11

ADDRESS CORRESPONDENCE TO ATTENTION OF:
CHUCK BOWMAN
304-558-2157

VENDOR

*709060417 304-984-1115
 CARPENTER RECLAMATION INC
 PO BOX 13015
 SISSONVILLE WV 25360-0015

SHIP TO

ENVIRONMENTAL PROTECTION
 DEPARTMENT OF
 OFFICE OF AML&R
 601 57TH STREET SE
 CHARLESTON, WV
 25304 304-926-0499

| DATE PRINTED | TERMS OF SALE | SHIP VIA | F.O.B. | FREIGHT TERMS |
|--------------|---------------|----------|--------|---------------|
| 01/16/2008 | | | | |

BID OPENING DATE: **02/28/2008** BID OPENING TIME **01:30PM**

| LINE | QUANTITY | UOP | CAT NO. | ITEM NUMBER | UNIT PRICE | AMOUNT |
|--|----------|-----|---------|-------------|------------|--------|
| <p>OPENING DATE.</p> <p>(3) ALL ADDENDA SHOULD BE FORMALLY ACKNOWLEDGED BY ALL BIDDERS AND SUBMITTED TO THE STATE PURCHASING DIVISION AND THE STATE AUDITOR'S OFFICE. THE SAME RULES AND REGULATIONS THAT APPLY TO THE ORIGINAL BIDDING DOCUMENT SHALL ALSO APPLY TO AN ADDENDUM DOCUMENT. THE ONLY EXCEPTION MAY BE FOR AN ADDENDUM THAT IS ISSUED FOR THE SOLE PURPOSE OF CHANGING A BID OPENING TIME AND/OR DATE.</p> <p>REV. 11/96</p> <p>EXHIBIT 10</p> <p style="text-align: center;">REQUISITION NO.: .DEP14241</p> <p>ADDENDUM ACKNOWLEDGEMENT</p> <p>I HEREBY ACKNOWLEDGE RECEIPT OF THE FOLLOWING CHECKED ADDENDUM(S) AND HAVE MADE THE NECESSARY REVISIONS TO MY PROPOSAL, PLANS AND/OR SPECIFICATION, ETC.</p> <p>ADDENDUM NO.'S:</p> <p>NO. 1 ✓</p> <p>NO. 2</p> <p>NO. 3</p> <p>NO. 4</p> <p>NO. 5</p> | | | | | | |

SEE REVERSE SIDE FOR TERMS AND CONDITIONS

SIGNATURE *KC* TELEPHONE DATE *2/5/08*

TITLE FEIN ADDRESS CHANGES TO BE NOTED ABOVE

WHEN RESPONDING TO RFQ, INSERT NAME AND ADDRESS IN SPACE ABOVE LABELED 'VENDOR'



State of West Virginia
 Department of Administration
 Purchasing Division
 2019 Washington Street East
 Post Office Box 50130
 Charleston, WV 25305-0130

Request for Quotation

RFQ NUMBER
DEP14241

PAGE
12

ADDRESS CORRESPONDENCE TO ATTENTION OF
CHUCK BOWMAN
304-558-2157

VENDOR

*709060417 304-984-1115
CARPENTER RECLAMATION INC
PO BOX 13015

SISSONVILLE WV 25360-0015

SHIP TO

ENVIRONMENTAL PROTECTION
DEPARTMENT OF
OFFICE OF AML&R
601 57TH STREET SE
CHARLESTON, WV
25304 **304-926-0499**

| DATE PRINTED | TERMS OF SALE | SHIP VIA | F.O.B. | FREIGHT TERMS |
|--------------|---------------|----------|--------|---------------|
| 01/16/2008 | | | | |

BID OPENING DATE: **02/28/2008** BID OPENING TIME **01:30PM**

| LINE | QUANTITY | UOP | CAT NO | ITEM NUMBER | UNIT PRICE | AMOUNT |
|--|----------|-----|--------|-------------|------------|--------|
| <p>I UNDERSTAND THAT FAILURE TO CONFIRM THE RECEIPT OF THE ADDENDUM(S) MAY BE CAUSE FOR REJECTION OF BIDS.</p> <p style="text-align: center;"> <i>Kelly Carpenter</i> SIGNATURE <i>Carpenter Reclamation Inc.</i> COMPANY ... 3/5/08 ... DATE </p> <p>REV. 11/96</p> <p style="text-align: center;">NOTICE</p> <p>A SIGNED BID MUST BE SUBMITTED TO:</p> <p style="text-align: center;"> DEPARTMENT OF ADMINISTRATION PURCHASING DIVISION BUILDING 15 2019 WASHINGTON STREET, EAST CHARLESTON, WV 25305-0130 </p> <p>THE BID SHOULD CONTAIN THIS INFORMATION ON THE FACE OF THE ENVELOPE OR THE BID MAY NOT BE CONSIDERED:</p> <p>SEALED BID</p> <p>BUYER: CB-23</p> | | | | | | |

SEE REVERSE SIDE FOR TERMS AND CONDITIONS

| | | |
|------------------------|-----------|-----------------------------------|
| SIGNATURE <i>KC</i> | TELEPHONE | DATE <i>3/5/08</i> |
| TITLE | FEIN | ADDRESS CHANGES TO BE NOTED ABOVE |

WHEN RESPONDING TO RFQ, INSERT NAME AND ADDRESS IN SPACE ABOVE LABELED 'VENDOR'



State of West Virginia
 Department of Administration
 Purchasing Division
 2019 Washington Street East
 Post Office Box 50130
 Charleston, WV 25305-0130

Request for Quotation

RFQ NUMBER
 DEP14241

PAGE
 13

ADDRESS CORRESPONDENCE TO ATTENTION OF:
 CHUCK BOWMAN
 304-558-2157

VENDOR

*709060417 304-984-1115
 CARPENTER RECLAMATION INC
 PO BOX 13015
 SISSONVILLE WV 25360-0015

SHIP TO

ENVIRONMENTAL PROTECTION
 DEPARTMENT OF
 OFFICE OF AML&R
 601 57TH STREET SE
 CHARLESTON, WV
 25304 304-926-0499

| | | | | |
|--------------|---------------|----------|--------|---------------|
| DATE PRINTED | TERMS OF SALE | SHIP VIA | F.O.B. | FREIGHT TERMS |
| 01/16/2008 | | | | |

BID OPENING DATE: 02/28/2008 BID OPENING TIME 01:30PM

| LINE | QUANTITY | UOP | CAT NO | ITEM NUMBER | UNIT PRICE | AMOUNT |
|---|----------|-----|--------|------------------------------|------------|----------------------|
| | | | | RFQ. NO.: DEP14242 | | |
| | | | | BID OPENING DATE: 02/28/2008 | | |
| | | | | BID OPENING TIME: 1:30 PM | | |
| PLEASE PROVIDE A FAX NUMBER IN CASE IT IS NECESSARY TO CONTACT YOU REGARDING YOUR BID: ----- 304-984-1115 ----- CONTACT PERSON (PLEASE PRINT CLEARLY): Randy Carpenter 984-1115 543-1726 ----- | | | | | | |
| ***** THIS IS THE END OF RFQ DEP14241 ***** | | | | | | TOTAL: \$ 134,800.00 |

SEE REVERSE SIDE FOR TERMS AND CONDITIONS

| | | |
|------------------------|-----------|-----------------------------------|
| SIGNATURE <i>KC</i> | TELEPHONE | DATE 3/5/08 |
| TITLE | FEIN | ADDRESS CHANGES TO BE NOTED ABOVE |

WHEN RESPONDING TO RFQ INSERT NAME AND ADDRESS IN SPACE ABOVE LABELED 'VENDOR'

RFQ#: DEP14241
Bid Date: 02/28/2008
Opening: 1:30 pm

014

**WHITMAN (WILLIAMS) DRAINAGE
BID SHEET**

The bidder agrees to furnish all labor, equipment, and other necessary services for the reclamation of the Whitman (Williams) Drainage project.

The quantity of work done will be paid at the contract lump sum price bid. Payment of said lump sum shall constitute full compensation for doing all the work outlined in the specifications and shown on the plan sheets in a workmanlike and acceptable manner, including the furnishings of all labor, materials, tools, equipment, supplies, and incidentals necessary to complete the work.

TOTAL LUMP SUM BID: \$ 134,800.00
COMPANY: Carpenter Reclamation Inc.
SIGNATURE: Kelly Carpenter
DATE: 3-5-08

RFQ#: DEP14241
Bid Date: 02/28/2008
Opening: 1:30 pm

OMB #1029-0119
Expiration Date: 01/31/2010

015

AML CONTRACTOR INFORMATION FORM

You must complete this form for your AML contracting officer to request an AML eligibility evaluation from the Office of Surface Mining to determine if you are eligible to receive an AML contract. This eligibility requirement applies to contractors and their sub-contractors and is found under OSM's regulations at 30 CFR 874.16.

Part A: General Information

Contractor Name: Carpenter Reclamation Tax Payer ID No.: 55-069349-3
Address: P.O. 13015
City: Seasonville State: WV Zip Code: 25340 Phone: 984-1115
Fax No.: 984-2770 E-mail address: RCARPEN103@AOL.COM

Part B: Legal Structure

Corporation () Sole Proprietorship () Partnership () LLC
() Other (please specify) _____

Part C: Certifying and updating information in the Applicant/Violator System (AVS).

Select only one of the following options, follow the instructions for that option, and sign below.

I, Kelly Carpenter, have the express authority to certify that:
(print name)

Information on the attached Entity OFT from AVS is accurate, complete, and up-to-date. If you select this option, you **must** attach an Entity OFT from AVS to this form. Sign and date below and do not complete Part D.

Part of the information on the attached Entity OFT from AVS is missing or incorrect and the information in AVS for my company must be updated. If you select this option, you **must** attach an Entity OFT from AVS to this form. Use Part D to provide missing or corrected information. Sign and date below and complete Part D.

Our company currently has no information in AVS. If you select this option, you must provide all information required in Part D. Sign and date below and complete Part D.

3/5/08
Date

K. Carpenter
Signature

President
Title

IMPORTANT!

In order to certify in Part C to the accuracy of existing information in AVS, you must obtain a copy of your business' Entity OFT. To obtain an Entity OFT, contact the AVS Office, toll-free, at 800-643-9748 or request it from www.avs.osmre.gov on the Internet.

Part D.

Contractor Name:

Carpenter Reclamation Inc.

If the current entity and Entity OFT information for your business is incomplete or incorrect in AVS, or if there is no information in AVS for your business, you must provide all of the following information as it applies to your business affiliations. Please make as many copies of this page as you require.

- Every officer (President, Vice President, Secretary, Treasurer, etc.);
- All Directors;
- All persons performing a function similar to a Director;
- Every person or business that owns 10% or more of the voting stock in your business;
- Every partner, if your business is a partnership;
- Every member and manager, if your business is a limited liability company; and
- Any other person(s) who has the ability to determine the manner in which the AML reclamation project is being conducted.

Name N/A Position/Title _____
Address _____ Telephone # _____
Begin Date: _____ % of Ownership _____
Ending Date: _____

Name _____ Position/Title _____
Address _____ Telephone # _____
Begin Date: _____ % of Ownership _____
Ending Date: _____

Name _____ Position/Title _____
Address _____ Telephone # _____
Begin Date: _____ % of Ownership _____
Ending Date: _____

Name _____ Position/Title _____
Address _____ Telephone # _____
Begin Date: _____ % of Ownership _____
Ending Date: _____

PAPERWORK REDUCTION STATEMENT

The Paperwork Reduction Act of 1995 (44 U.S.C. 3501) requires us to inform you that: Federal Agencies may not conduct or sponsor, and a person is not required to respond to, a collection of information unless it displays a currently valid OMB control number. This information is necessary for all successful bidders prior to the distribution of AML funds, and is required to obtain a benefit.

Public reporting burden for this form is estimated to average 45 minutes per response, including time for reviewing instructions, gathering and maintaining data, and completing and reviewing the form. Direct comments regarding the burden estimate or any other aspect of this form to the Information Collection Clearance Officer, Office of Surface Mining Reclamation and Enforcement, Room 210 SIB, Constitution Ave., NW, Washington, D.C. 20240.

BID BOND

017

KNOW ALL MEN BY THESE PRESENTS, That we, the undersigned, _____
of _____, _____, as Principal, and _____
of _____, _____, a corporation organized and existing under the laws of the State of _____
with its principal office in the City of _____, as Surety, are held and firmly bound unto the State
of West Virginia, as Obligee, in the penal sum of _____ (\$ _____) for the payment of which,
well and truly to be made, we jointly and severally bind ourselves, our heirs, administrators, executors, successors and assigns.

The Condition of the above obligation is such that whereas the Principal has submitted to the Purchasing Section of the
Department of Administration a certain bid or proposal, attached hereto and made a part hereof, to enter into a contract in writing for

NOW THEREFORE,

- (a) If said bid shall be rejected, or
- (b) If said bid shall be accepted and the Principal shall enter into a contract in accordance with the bid or proposal attached
hereto and shall furnish any other bonds and insurance required by the bid or proposal, and shall in all other respects perform the
agreement created by the acceptance of said bid, then this obligation shall be null and void, otherwise this obligation shall remain in full
force and effect. It is expressly understood and agreed that the liability of the Surety for any and all claims hereunder shall, in no event,
exceed the penal amount of this obligation as herein stated.

The Surety, for the value received, hereby stipulates and agrees that the obligations of said Surety and its bond shall be in no
way impaired or affected by any extension of the time within which the Obligee may accept such bid, and said Surety does hereby
waive notice of any such extension.

IN WITNESS WHEREOF, Principal and Surety have hereunto set their hands and seals, and such of them as are corporations
have caused their corporate seals to be affixed hereunto and these presents to be signed by their proper officers, this
_____ day of _____, 20____.

Principal Corporate Seal

See Attached

(Name of Principal)

By _____
(Must be President or
Vice President)

(Title)

Surety Corporate Seal

(Name of Surety)

Attorney-in-Fact

**IMPORTANT - Surety executing bonds must be licensed in West Virginia to transact surety insurance. Raised corporate seals
must be affixed, a power of attorney must be attached.**

BID BOND PREPARATION INSTRUCTIONS

018
AGENCY (A)
RFQ/RFP# (B)

Bid Bond

- (A) WV State Agency
(Stated on Page 1 "Spending Unit")
Request for Quotation Number (upper
right corner of page #1)
- (C) Your Company Name
- (D) City, Location of your Company
- (E) State, Location of your Company
- (F) Surety Corporate Name
- (G) City, Location of Surety
- (H) State, Location of Surety
- (I) State of Surety Incorporation
- (J) City of Surety Incorporation
- (K) Minimum amount of acceptable bid
bond is 5% of total bid. You may state
"5% of bid" or a specific amount on
this line in words.
- (L) Amount of bond in figures
- (M) Brief Description of scope of work
- (N) Day of the month
- (O) Month
- (P) Year
- (Q) Name of Corporation
- (R) Raised Corporate Seal of Principal
- (S) Signature of President or Vice
President
- (T) Title of person signing
- (U) Raised Corporate Seal of Surety
- (V) Corporate Name of Surety
- (W) Signature of Attorney in Fact of the
Surety

NOTE: Dated, Power of Attorney with Raised
Surety Seal must accompany this bid
bond.

KNOW ALL MEN BY THESE PRESENTS, That we, the undersigned,
 (C) of (D) of (E)
 as Principal, and (F) of (G)
 (H), a corporation organized and existing under the laws
 of the State of (I) with its principal office in the City of
 (J), as Surety, are held and firmly bound unto The State
 of West Virginia, as Obligee, in the penal sum of (K)
 (\$ (L)) for the payment of which, well and truly to be made,
 we jointly and severally bind ourselves, our heirs, administrators, executors,
 successors and assigns.

The Condition of the above obligation is such that whereas the Principal
 has submitted to the Purchasing Section of the Department of Administration
 a certain bid or proposal, attached hereto and made a part hereof to enter into a
 contract in writing for (M)

NOW THEREFORE.

(a) If said bid shall be rejected, or
 (b) If said bid shall be accepted and the Principal shall enter into a
 contract in accordance with the bid or proposal attached hereto and shall furnish
 any other bonds and insurance required by the bid or proposal, and shall in all
 other respects perform the agreement created by the acceptance of said bid then
 this obligation shall be null and void, otherwise this obligation shall remain in full
 force and effect. It is expressly understood and agreed that the liability of the
 Surety for any and all claims hereunder shall, in no event, exceed the penal
 amount of this obligation as herein stated

The Surety for value received, hereby stipulates and agrees that the
 obligations of said Surety and its bond shall be in no way impaired or affected by
 any extension of time within which the Obligee may accept such bid: and said
 Surety does hereby waive notice of any such extension.

IN WITNESS WHEREOF, Principal and Surety have hereunto set their
 hands and seals, and such of them as are corporations have caused their corporate
 seals to be affixed hereto and these presents to be signed by their proper officers,
 this (N) day of (O), 20 (P).

Principal Corporate Seal

(R)

(Q)
 (Name of Principal)
 By (S)
 (Must be President or
 Vice President)
 (T)
 Title

Surety Corporate Seal

(U)

(V)
 (Name of Surety)
 (W)
 Attorney-in-Fact

IMPORTANT – Surety executing bonds must be licensed in West Virginia to
 transact surety insurance. Raised Corporate Seals must be affixed and a Power of
 Attorney must be attached.

STATE OF WEST VIRGINIA
Purchasing Division

019

PURCHASING AFFIDAVIT

West Virginia Code §5A-3-10a states: No contract or renewal of any contract may be awarded by the state or any of its political subdivisions to any vendor or prospective vendor when the vendor or prospective vendor or a related party to the vendor or prospective vendor is a debtor and the debt owed is an amount greater than one thousand dollars in the aggregate

DEFINITIONS:

"Debt" means any assessment, premium, penalty, fine, tax or other amount of money owed to the state or any of its political subdivisions because of a judgment, fine, permit violation, license assessment, defaulted workers' compensation premium, penalty or other assessment presently delinquent or due and required to be paid to the state or any of its political subdivisions, including any interest or additional penalties accrued thereon.

"Debtor" means any individual, corporation, partnership, association, limited liability company or any other form or business association owing a debt to the state or any of its political subdivisions. "Political subdivision" means any county commission; municipality; county board of education; any instrumentality established by a county or municipality; any separate corporation or instrumentality established by one or more counties or municipalities, as permitted by law; or any public body charged by law with the performance of a government function or whose jurisdiction is coextensive with one or more counties or municipalities. "Related party" means a party, whether an individual, corporation, partnership, association, limited liability company or any other form or business association or other entity whatsoever, related to any vendor by blood, marriage, ownership or contract through which the party has a relationship of ownership or other interest with the vendor so that the party will actually or by effect receive or control a portion of the benefit, profit or other consideration from performance of a vendor contract with the party receiving an amount that meets or exceeds five percent of the total contract amount.

EXCEPTION: The prohibition of this section does not apply where a vendor has contested any tax administered pursuant to chapter eleven of this code, workers' compensation premium, permit fee or environmental fee or assessment and the matter has not become final or where the vendor has entered into a payment plan or agreement and the vendor is not in default of any of the provisions of such plan or agreement.

LICENSING: Vendors must be licensed and in good standing in accordance with any and all state and local laws and requirements by any state or local agency of West Virginia, including, but not limited to, the West Virginia Secretary of State's Office, the West Virginia Tax Department, West Virginia Insurance Commission, or any other state agencies or political subdivision. Furthermore, the vendor must provide all necessary releases to obtain information to enable the Director or spending unit to verify that the vendor is licensed and in good standing with the above entities.

CONFIDENTIALITY: The vendor agrees that he or she will not disclose to anyone, directly or indirectly, any such personally identifiable information or other confidential information gained from the agency, unless the individual who is the subject of the information consents to the disclosure in writing or the disclosure is made pursuant to the agency's policies, procedures and rules. Vendors should visit www.state.wv.us/admin/purchase/privacy for the Notice of Agency Confidentiality Policies.

Under penalty of law for false swearing (West Virginia Code, §61-5-3), it is hereby certified that the vendor acknowledges the information in this said affidavit and are in compliance with the requirements as stated.

Vendor's Name: Carpenter Reclamation Inc.Authorized Signature: Kelly CarpenterDate: 3/15/08

Date: 19-Jan-2006

Applicant Violator System
Organizational Family Tree (OFT)

Time :08:20:59

Page: 1

(140618) CARPENTER RECLAMATION INC

Total Number: 4

| Entity ID | Name | Desc Code | Begln Dat: | End Date | Pct. Own. | Hold Code |
|-----------|-------------------|-----------|------------|----------|-----------|-----------|
| 140616 | CARPENTER, KELLEY | PRS | 1-Oct-1989 | | | |
| 140616 | CARPENTER, KELLEY | SH | 1-Oct-1989 | | 50% | |
| 140617 | CARPENTER, MARY | VP | 1-Oct-1989 | | | |
| 140617 | CARPENTER, MARY | SH | 1-Oct-1989 | | 50% | |

Current Information
K. Carpenter - President
3/5/08



State of West Virginia
 Department of Administration
 Purchasing Division
 2019 Washington Street East
 Post Office Box 50130
 Charleston, WV 25305-0130

Request for Quotation

RFQ NUMBER:
 DEP14241

PAGE:
 1

ADDRESS CORRESPONDENCE TO ATTENTION OF:
 CHUCK BOWMAN
 304-558-2157

VENDOR

*709060417 304-984-1115
 CARPENTER RECLAMATION INC
 PO BOX 13015

 SISSONVILLE WV 25360-0015

SHIP TO

ENVIRONMENTAL PROTECTION
 DEPARTMENT OF
 OFFICE OF AML&R
 601 57TH STREET SE
 CHARLESTON, WV
 25304 304-926-0499

| DATE PRINTED | TERMS OF SALE | SHIP VIA | F.O.B. | FREIGHT TERMS |
|--------------|---------------|----------|--------|---------------|
| 02/19/2008 | | | | |

BID OPENING DATE: **03/05/2008** BID OPENING TIME **01:30PM**

| LINE | QUANTITY | UOP | CAT NO | ITEM NUMBER | UNIT PRICE | AMOUNT |
|---|----------|-----|--------|-------------|------------|------------|
| ***** ADDENDUM NO. 1 ***** ADDENDUM ISSUED FOR THE WHITMAN DRAINAGE PROJECT TO DISTRIBUTE THE SIGN-IN SHEET, Q/A, SKETCHES, AND TEST BORING LOGS RESULTING FROM THE 02/05/08 MANDATORY PRE-BID MEETING. BID DATE AND OPENING TIME HAVE BEEN EXTENDED TO 03/05/08 AT 1:30 PM ***** NO OTHER CHANGES ***** | | | | | | |
| 0001 | 1 | LS | | 962-73 | \$/ | 134,800.00 |
| RECLAMATION: RESTORATION OF LAND & OTHER PROPERTIES | | | | | | |

SEE REVERSE SIDE FOR TERMS AND CONDITIONS

SIGNATURE: *Kelley Carpenter* TELEPHONE: *984-1115* DATE: *3/5/08*
 TITLE: *President* FEIN: *550693493* ADDRESS CHANGES TO BE NOTED ABOVE

WHEN RESPONDING TO RFQ, INSERT NAME AND ADDRESS IN SPACE ABOVE LABELED 'VENDOR'

MANDATORY PRE-BID SIGN-IN ATTENDANCE SHEET

PRINT LEGIBLY

002

RFQ # : DEP14241
Project: Whitman (Williams) Drainage

Bid Date: 2/28/08
Pre-Bid Date: 2/5/08

Name : Robert Baines
Company: Baines EXC. INC
Address: P.O. Box 13384
Sissonville
WV 25360
Phone #: 984-1725
Fax #: 984-0074
Email : none

Name : Allen Marker
Company: Garcie R. Marker & Sons
Address: 1119 Jefferson Rd.
So. Chas. Wv, 25309
Phone #: 744-DS9D
Fax #: 746-5203
Email :

Name : GARY Long
Company: M Court & Son Const.
Address: 2790 Centralia Rd
Sutton WV 26601
Phone #: 304 765-5288
Fax #: 304 765-5293
Email :

Name : DAVID H. BOWMAN
Company: GREEN MOUNTAIN CO
Address: 511 50th STREET
CHARLESTON WV
25304
Phone #: 304 925-0253
Fax #: 925 9230
Email : Jody Maye@AOL.COM

Name ★: Wes Addair
Company: A-A ENERGY INC
Address: 151 STEWART ST
WELCH WVA
24801
Phone #: 304-320-3961
Fax #: 304 436-5111
Email : WesAddair@hotmail.com

Name : Archie E. Hubbard
Company: Acme-Ventures
Address: 138 Renee Drive
PO Box 217
Peytona, WV 25154
Phone #: (304) 932-0721
Fax #: 932-0725
Email : Archie@wvexcavator.com

Name ★: Samuel G. Hazzard Jr.
Company: Hazzard's Exc.
Address: P.O. Box 398
Kimball, WVA. 24853
Phone #: 585-7060
Fax #: 585-7062
Email :

Name : Doug Vincent
Company: Breakaway Inc.
Address: 1075 Old Turnpike Rd
Sutton, WV 26601
Phone #: 765-5317
Fax #: 765-5389
Email :

MANDATORY PRE-BID SIGN-IN ATTENDANCE SHEET

003

PRINT LEGIBLY

RFQ # : DEP14241
Project: Whitman(Williams) Drainage

Bid Date: 2/28/08
Pre-Bid Date: 2/5/08

Name [★] : Dale Thexton
Company: Thexton Const Co Inc
Address: PO Box 13279 Charleston
WV 25360

Name : _____
Company: _____
Address: _____

Phone #: 304 984 2249
Fax #: 984 2334
Email : _____

Phone# : _____
Fax # : _____
Email : _____

Name : BASIL CARPENTER
Company: JANN B 2nd INC
Address: 333 A Cell RD
Char WV 25312

Name : _____
Company: _____
Address: _____

Phone #: (304) 984-0388
Fax #: 784-3528
Email : _____

Phone# : _____
Fax # : _____
Email : _____

Name : MARVIN REYNOLDS
Company: DIRTWORKS DEVELOPMENT
Address: 4529 BLANKENSHIP RD.
HUNTINGTON WV 25701

Name : _____
Company: _____
Address: _____

Phone #: 304 736-3719
Fax #: 304 736-8242
Email : dirtworks979@netzero.net

Phone# : _____
Fax # : _____
Email : _____

Name : _____
Company: _____
Address: _____

Name : _____
Company: _____
Address: _____

Phone #: _____
Fax #: _____
Email : _____

Phone# : _____
Fax # : _____
Email : _____

MANDATORY PRE-BID SIGN-IN ATTENDANCE SHEET

PRINT LEGIBLY

004

RFQ # : DEP 14241
Project: Whitman (William) Damage

Bid Date: 2/28/08
Pre-Bid Date: 2/5/08

Name : JACK KEELY
Company: GROUND BREAKERS
Address: P.O. Box 1227
CLARKSBURG WV
26302
Phone #: 304 622-2400
Fax #: 622-2410
Email : _____

Name : GEORGE FRESHOUR
Company: EAGLE EXCAVATION INC
Address: P.O. BOX 218
KENNA WV 25240
Phone #: (304) 372-4378
Fax #: (304) 372-4378
Email : NONE

Name : Bernie McCount
Company: Mountain Movers
Address: 5 Stoony Creek
Sutton wva
Phone #: (304) 765-5003
Fax #: (304) 765-5003
Email : _____

Name : Ann Wardwell
Company: EASTERN AIRLOW *
Address: P.O. Box 4108 LEFT
CHARLESTON, WV SIDE
2 DEB
Phone #: 304 414 6255
Fax #: 6256
Email : _____

Name : Chris Ward
Company: Golf Design Inc.
Address: 1300 Sulliver Rd
Beaver WV 25813
Phone #: 256 0908
Fax #: 256-2482
Email : Ward1@PeoplePC

Name : Robert Dinger
Company: DowUnder CONST
Address: Rt 2 Box 157C
Harts wv
Phone #: 304 855-2384
Fax #: 304 784-2775
Email : _____

Name : Randy Carpenter
Company: Carpenter Reclamation
Address: PO Box 13015
Sissonville, WV
25360
Phone #: 984-1115
Fax #: 984-2770
Email : _____

Name : TRIP SHOWN
Company: BASE ENVIRONMENTAL GROUP
Address: 4200 FIRST AVE, SUITE 104
NITRO, WV 25143
Phone #: 304 204 2500
Fax #: 304 204 2520
Email : TRIP@BASE ENV Com

Req # DEP 14241**Whitman (Williams) Drainage Prebid Addendum #1**

The following additions/questions/answers will not cause any increase in the lump sum bid for the project.

Include in the Construction Specifications, Special Provisions III, Scope of Work "The removal of monitoring wells".

Questions asked at the prebid meeting and answers

Q: Is the drilling elevation the same elevation as the roof of the mine?

A: Approximately the same as the top of the void. The void could be at the top of the coal elevation or slightly higher, depending on whether or not there was a roof fall.

Q: Is there an opening that we are going to drill through?

A: The material that the contractor is going to drill through is unknown. It could be a mixture of collapsed rock, rock backfill and soil. The drilling could be difficult.

Q: Was there a punchout here?

A: It is unknown whether or not there was an active entry here or if the miners punched out from the inside.

Q: If we drill into a void can we stop?

A: No, we want to hit the main body of water at the target location. There could be voids that do not reach the main location.

Q: Is the drill angle 9%?

A: Yes as is shown on the drawings.

Q: Is the monitoring well up there on the hill. If we start here that will be much less than the 75' shown on the profile?

A: The drilling will begin farther down the hill from where we are standing. The drilling will begin at the location shown on the drawing.

Q: Can we face up closer?

A: With approval of the WVDEP but need to maintain the proposed drill elevation.

Q: Are there animal guards required for the mine overflow pipes?

A: Yes, an animal guard detail drawing has been attached.

Q: What are we going to do with this corner? (A rock overhang that has a roof fall beneath it that is located approximately 50' north of the mine overflow pipe).

A: The overhang will need to be backfilled according to the included Specification 9.3.2.

Add Construction Specification 9.3.2 – The rock overhang shall be backfilled with onsite material

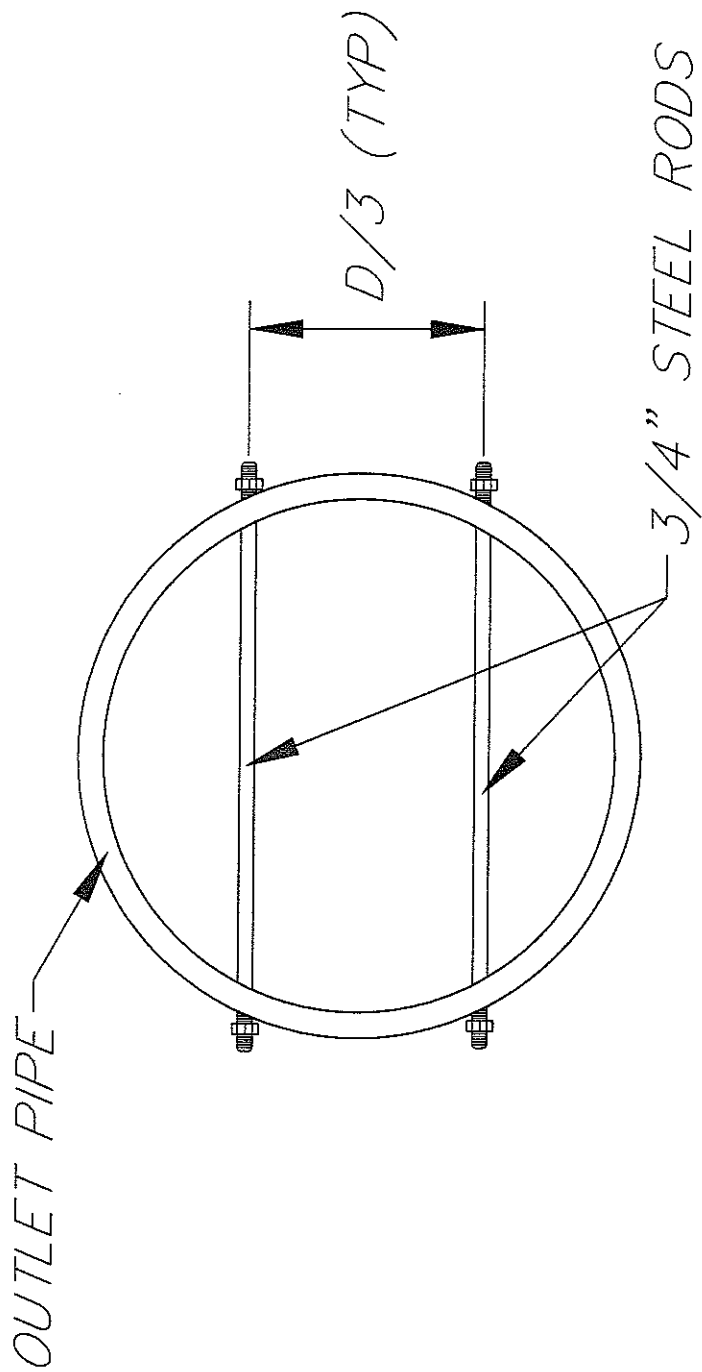

TYPICAL ANIMAL GUARD
DETAIL



TEST BORING LOG

CLIENT WVDEP/AML BORING NO. B-1
 PROJECT WHITMAN (WILLIAMS) DRAINAGE JOB NO. 04-07-0305
 LOCATION OF BORING _____

| SOIL / ROCK DESCRIPTION, | Strata Depth | Depth Scale | SAMPLE | | | | |
|--|--------------|-------------|------------|-----|------|------|------|
| | | | Blows / 6" | No. | Type | Rec. | ROD |
| SURFACE | 0.0 | 0.0 | | | | | |
| Weathered Brown sandstone Auger Refusal | | 8.0 | | | | | |
| Gray sandstone and shale mixed Coal 59.2 to 65.9 into gray shale BTS 68.0 | | 13.0 | / | 1 | RC | 5.0 | 5.0 |
| | | 23.0 | / | 2 | RC | 10.0 | 7.3 |
| | | 33.0 | / | 3 | RC | 9.7 | 6.10 |
| | | 43.0 | / | 4 | RC | 10.0 | 7.9 |
| | | 53.0 | / | 5 | RC | 10.0 | 6.8 |
| | | 63.0 | / | 6 | RC | 10.0 | 6.0 |
| | | 68.0 | / | 7 | RC | 5.5 | 2.5 |

Surf. Elev. N/A Ft. Hammer Wt. N/A lbs. Rock Core Dia. 3.0
 Date: 8-1-07 Hammer Drop N/A in. Boring Method HCA Foreman RAC
 Engineer TAT

- | | | |
|--------------------------|-------------------------------|--|
| <u>Sampler Type</u> | <u>Ground Water Depth</u> | <u>Boring Method</u> |
| SS - DRIVEN SPLIT SPOON | FIRST NOTED <u>Nil</u> FT. | <input checked="" type="checkbox"/> HSA - HOLLOW STEM AUGERS |
| ST - PRESSED SHELBY TUBE | AT COMPLETION <u>72.5</u> FT. | <input type="checkbox"/> CFA - CONTINUOUS FLIGHT AUGERS |
| A - FLIGHT AUGER | AFTER _____ HRS. _____ FT. | <input type="checkbox"/> DC - DRIVING CASING |
| RC - ROCK CORE | BACKFILLED _____ HRS. | <input type="checkbox"/> MD - MUD DRILLING |



TRIAD ENGINEERING, INC.
 ST. ALBANS & MORGANTOWN, WEST VIRGINIA
 OFFICES IN VIRGINIA, MARYLAND & PENNSYLVANIA

TEST BORING LOG

CLIENT WVDEP/AML BORING NO. B-1A
 PROJECT WHITMAN (WILLIAMS) DRAINAGE JOB NO. 04-01-0385
 LOCATION OF BORING _____

| SOIL / ROCK DESCRIPTION | Strata Depth | Depth Scale | SAMPLE | | | | |
|---------------------------|--------------|-------------|------------|-----|------|------|-----|
| | | | Blows / 6" | No. | Type | Rec. | RQD |
| SURFACE | 0.0 | 0-0 | | | | | |
| Weathered Brown Sandstone | | 8-0 | | | | | |
| Riser Refusal | | 13-0 | | | RC | | |
| Good Gray Sandstone and | | 23-0 | | 2 | RC | | |
| Shale mixed | | 33-0 | | 3 | RC | | |
| | | 43-0 | | 4 | RC | | |
| | | 53-0 | | 5 | RC | | |
| void | | 63-0 | | 6 | RC | | |
| 59.2 to 60.4 | | 68-0 | | 7 | RC | | |
| 13.73-68-0 | | | | | | | |
| 60' Riser | | | | | | | |
| 10' SCREEN | | | | | | | |

Surf. Elev. N/A Ft. Hammer Wt. N/A Lbs. Rock Core Dia. _____
 Date: 8-1-07 Hammer Drop N/A In. Boring Method HSA Foreman RAC
 Engineer TJS

Sampler Type
 SS - DRIVEN SPLIT SPOON
 ST - PRESSED SHELBY TUBE
 A - FLIGHT AUGER
 RC - ROCK CORE

Ground Water Depth
 FIRST NOTED _____ FT.
 AT COMPLETION 58.0 FT.
 AFTER _____ HRS. 58.5 FT.
 BACKFILLED _____ HRS.

Boring Method
 HSA - HOLLOW STEM AUGERS
 CPA - CONTINUOUS FLIGHT AUGERS
 DC - DRIVING CASING
 MD - MUD DRILLING



TEST BORING LOG

CLIENT WVDEP/AML BORING NO. B-2
 PROJECT WHITMAN (WILLIAMS) DRAINAGE JOB NO. 04-07-0305
 LOCATION OF BORING _____

| SOIL / ROCK DESCRIPTION | Strata Depth | Depth Scale | SAMPLE | | | | |
|---|--------------|-------------|------------|-----|------|------|-----|
| | | | Blows / 6" | No. | Type | Rec. | RQD |
| SURFACE | 0.0 | 0.0 | | | | | |
| BROWN & GRAY SANDSTONE COAL 49.9 TO 57.4 BTB 60.0 | | 4.0 | | | | | |
| | | 13.0 | / | 1 | RC | 9.0 | 4.7 |
| | | 23.0 | / | 2 | RC | 10.0 | 7.0 |
| | | 33.0 | / | 3 | RC | 9.2 | 7.8 |
| | | 43.0 | / | 4 | RC | 9.4 | 7.5 |
| | | 53.0 | / | 5 | RC | 10.0 | 6.0 |
| | 60.0 | / | 6 | RC | | | |

Surf. Elev. _____ Ft. Hammer Wt. 140 Lbs. Rock Core Dia. 3.0
 Date 9-1-07 Hammer Drop MD In. Boring Method HSA Foreman DNL
 Engineer TAT

- | | | |
|---|---|--|
| <p><u>Sampler Type</u></p> <p>SS - DRIVEN SPLIT SPOON ST - PRESSED SHELBY TUBE A - FLIGHT AUGER RC - ROCK CORE</p> | <p><u>Ground Water Depth</u></p> <p>FIRST NOTED <u>Dr</u> FT. AT COMPLETION <u>57.0</u> FT. AFTER _____ HRS. FT. BACKFILLED _____ HRS.</p> | <p><u>Boring Method</u></p> <p><u>HSA</u> - HOLLOW STEM AUGERS CFA - CONTINUOUS FLIGHT AUGERS DC - DRIVING CASING MD - MUD DRILLING</p> |
|---|---|--|



TRIAD ENGINEERING, INC.
ST. ALBANS & MORGANTOWN, WEST VIRGINIA
OFFICES IN VIRGINIA, MARYLAND & PENNSYLVANIA

TEST BORING LOG

CLIENT WADEP/AML BORING NO. B-2A
PROJECT WHITMAN (WILLIAMS) DRAINAGE JOB NO. 04-07-0305
LOCATION OF BORING _____

| SOIL / ROCK DESCRIPTION | Strata Depth | Depth Scale | SAMPLE | | | | |
|--------------------------|--------------|-------------|------------|-----|------|------|-----|
| | | | Blows / 6" | No. | Type | Rec. | RQD |
| SURFACE | 0.0 | | A | | | | |
| Good Sand Stone | | 5.0 | | | | | |
| | | 10.0 | | | | | |
| | | 15.0 | | | | | |
| | | 20.0 | | | | | |
| | | 25.0 | | | | | |
| | | 30.0 | | | | | |
| | | 35.0 | | | | | |
| 8-1.07 | | 43.5 | | | | | |
| Small void 46.0 to 46.10 | | 53.0 | | | | | |
| void 49.0 to 58.9 | | 63.0 | | | | | |
| INTO SANDSTONE AT 58.9 | | | | | | | |
| PT B-630 | | | | | | | |
| 20' SCREEN | | | | | | | |
| 40' R.SLV | | | | | | | |

Surf. Elev. _____ Ft. Hammer Wt. MA Lbs. Rock Core Dia. 7.0
Date: 8-2-07 Hammer Drop MP In. Boring Method HSD Foreman RC
Engineer TST

Sampler Type
 SS - DRIVEN SPLIT SPOON
 ST - PRESSED SHELBY TUBE
 A - FLIGHT AUGER
 RC - ROCK CORE

Ground Water Depth
 FIRST NOTED 52.3 FT.
 AT COMPLETION _____ FT.
 AFTER _____ HRS. _____ FT.
 BACKFILLED _____ HRS. _____ FT.

Boring Method
 HSA - HOLLOW STEM AUGERS
 CFA - CONTINUOUS FLIGHT AUGERS
 DC - DRIVING CASING
 MD - MUD DRILLING

BID BOND

KNOW ALL MEN BY THESE PRESENTS, That we, the undersigned, Carpenter Reclamation, Inc
of PO Box 13015 Sissonville, WV 25360, as Principal, and Western Surety Company
of U.S. Steel Tower, 600 Grant Street, Suite 500, Pittsburgh, PA a corporation organized and existing under the laws of the State of South Dakota with its principal office in the City of Sioux Falls, as Surety, are held and firmly bound unto the State of West Virginia, as Obligee, in the penal sum of Five Percent (\$ 5%) for the payment of which, well and truly to be made, we jointly and severally bind ourselves, our heirs, administrators, executors, successors and assigns.

The Condition of the above obligation is such that whereas the Principal has submitted to the Purchasing Section of the Department of Administration a certain bid or proposal, attached hereto and made a part hereof, to enter into a contract in writing for DEP 14241, Whitman (Williams) Drng. in Logan County, according to plans and specifications.

NOW THEREFORE,

(a) If said bid shall be rejected, or

(b) If said bid shall be accepted and the Principal shall enter into a contract in accordance with the bid or proposal attached hereto and shall furnish any other bonds and insurance required by the bid or proposal, and shall in all other respects perform the agreement created by the acceptance of said bid, then this obligation shall be null and void, otherwise this obligation shall remain in full force and effect. It is expressly understood and agreed that the liability of the Surety for any and all claims hereunder shall, in no event, exceed the penal amount of this obligation as herein stated.

The Surety, for the value received, hereby stipulates and agrees that the obligations of said Surety and its bond shall be in no way impaired or affected by any extension of the time within which the Obligee may accept such bid, and said Surety does hereby waive notice of any such extension.

IN WITNESS WHEREOF, Principal and Surety have hereunto set their hands and seals, and such of them as are corporations have caused their corporate seals to be affixed hereunto and these presents to be signed by their proper officers, this 13th day of February, 2008.

Principal Corporate Seal

Carpenter Reclamation
(Name of Principal)
By Kelley Carpenter
Kelley Carpenter (Must be President or Vice President)
President
(Title)

Surety Corporate Seal

Western Surety Company
(Name of Surety)
Ross E Johnson
Ross E Johnson Attorney-in-Fact

IMPORTANT – Surety executing bonds must be licensed in West Virginia to transact surety insurance. Corporate seals must be affixed, and a power of attorney must be attached.

Western Surety Company

POWER OF ATTORNEY APPOINTING INDIVIDUAL ATTORNEY-IN-FACT

Know All Men By These Presents, That WESTERN SURETY COMPANY, a South Dakota corporation, is a duly organized and existing corporation having its principal office in the City of Sioux Falls, and State of South Dakota, and that it does by virtue of the signature and seal herein affixed hereby make, constitute and appoint

Ross E. Johnson, Patricia C Baire, Beverly A Holstine, Kathryn K Arthur, Individually

of Charleston, WV, its true and lawful Attorney(s)-in-Fact with full power and authority hereby conferred to sign, seal and execute for and on its behalf bonds, undertakings and other obligatory instruments of similar nature

- In Unlimited Amounts -

and to bind it thereby as fully and to the same extent as if such instruments were signed by a duly authorized officer of the corporation and all the acts of said Attorney, pursuant to the authority hereby given, are hereby ratified and confirmed.

This Power of Attorney is made and executed pursuant to and by authority of the By-Law printed on the reverse hereof, duly adopted, as indicated, by the shareholders of the corporation.

In Witness Whereof, WESTERN SURETY COMPANY has caused these presents to be signed by its Senior Vice President and its corporate seal to be hereto affixed on this 23rd day of October, 2006.



WESTERN SURETY COMPANY

Paul T. Bruflat, Senior Vice President

State of South Dakota }
County of Minnehaha } ss

On this 23rd day of October, 2006, before me personally came Paul T. Bruflat, to me known, who, being by me duly sworn, did depose and say: that he resides in the City of Sioux Falls, State of South Dakota; that he is the Senior Vice President of WESTERN SURETY COMPANY described in and which executed the above instrument; that he knows the seal of said corporation; that the seal affixed to the said instrument is such corporate seal; that it was so affixed pursuant to authority given by the Board of Directors of said corporation and that he signed his name thereto pursuant to like authority, and acknowledges same to be the act and deed of said corporation.

My commission expires

November 30, 2012

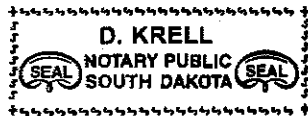

D. Krell, Notary Public

CERTIFICATE

I, L. Nelson, Assistant Secretary of WESTERN SURETY COMPANY do hereby certify that the Power of Attorney hereinabove set forth is still in force, and further certify that the By-Law of the corporation printed on the reverse hereof is still in force. In testimony whereof I have hereto subscribed my name and affixed the seal of the said corporation this 13th day of February 2008.



WESTERN SURETY COMPANY

L. Nelson, Assistant Secretary

Authorizing By-Law

ADOPTED BY THE SHAREHOLDERS OF WESTERN SURETY COMPANY

This Power of Attorney is made and executed pursuant to and by authority of the following By-Law duly adopted by the shareholders of the Company.

Section 7. All bonds, policies, undertakings, Powers of Attorney, or other obligations of the corporation shall be executed in the corporate name of the Company by the President, Secretary, and Assistant Secretary, Treasurer, or any Vice President, or by such other officers as the Board of Directors may authorize. The President, any Vice President, Secretary, any Assistant Secretary, or the Treasurer may appoint Attorneys in Fact or agents who shall have authority to issue bonds, policies, or undertakings in the name of the Company. The corporate seal is not necessary for the validity of any bonds, policies, undertakings, Powers of Attorney or other obligations of the corporation. The signature of any such officer and the corporate seal may be printed by facsimile.