



State of West Virginia  
 Department of Administration  
 Purchasing Division  
 2019 Washington Street East  
 Post Office Box 50130  
 Charleston, WV 25305-0130

# Request for Quotation

RFQ NUMBER  
**DEFK8220**

PAGE  
**1**

ADDRESS CORRESPONDENCE TO ATTENTION OF  
**JOHN ABBOTT**  
**304-558-2544**

RFQ COPY  
 TYPE NAME/ADDRESS HERE

**Glem Company**  
**P.O. Box 2109**  
**Charleston, WV 25328**

**DIV ENGINEERING & FACILITIES**  
**ARMORY BOARD SECTION**

**1707 COONSKIN DRIVE**  
**CHARLESTON, WV**  
**25311-1099 341-6368**

DATE PRINTED	TERMS OF SALE	SHIP VIA	FOB	FREIGHT TERMS
04/09/2008				

BID OPENING DATE: **05/15/2008** BID OPENING TIME **01:30PM**

LINE	QUANTITY	UOP	CAT. NO.	ITEM NUMBER	UNIT PRICE	AMOUNT
0001	1	LS		550-43	63,000. <sup>00</sup>	63,000. <sup>00</sup>
<p><b>TWO-STRAND CABLE VEHICULAR BARRIER</b></p> <p>CONTRACT TO PROVIDE ALL LABOR, MATERIALS, AND EQUIPMENT NECESSARY TO INSTALL A TWO-STRAND CABLE VEHICULAR BARRIER SYSTEM AT THE WV ARMY NATIONAL GUARD, CHARLESTON, WV, PER THE SPECIFICATIONS.</p> <p>MANDATORY ON-SITE PRE-BID: 4/29/2008; 10:30 AM            WVANG            1703 COONSKIN DRIVE            CHARLESTON, WV 25311            304-561-6539</p> <p>EXHIBIT 5</p> <p>NOTICE TO PROCEED: THIS CONTRACT IS TO BE PERFORMED WITHIN 90 CALENDAR DAYS AFTER THE NOTICE TO PROCEED IS RECEIVED. UNLESS OTHERWISE SPECIFIED, THE FULLY EXECUTED PURCHASE ORDER WILL BE CONSIDERED NOTICE TO PROCEED.</p> <p>CANCELLATION: THE DIRECTOR OF PURCHASING RESERVES THE RIGHT TO CANCEL THIS CONTRACT IMMEDIATELY UPON WRITTEN NOTICE TO THE VENDOR IF THE MATERIALS OR WORKMANSHIP SUPPLIED ARE OF AN INFERIOR QUALITY OR DO NOT CONFORM WITH THE SPECIFICATIONS OF THE BID AND CONTRACT HERE IN.</p> <p>WAGE RATES: THE CONTRACTOR OR SUBCONTRACTOR SHALL PAY</p>						

SEE REVERSE SIDE FOR TERMS AND CONDITIONS

SIGNATURE <i>Ken K. Hoffmann, C.S.</i>	TELEPHONE 304-342-2721	DATE 5/22/2008
TITLE CORPORATE SECRETARY	FEIN 55-0179050	ADDRESS CHANGES TO BE NOTED ABOVE

WHEN RESPONDING TO RFQ, INSERT NAME AND ADDRESS IN SPACE ABOVE LABELED 'VENDOR'

**GENERAL TERMS & CONDITIONS  
REQUEST FOR QUOTATION (RFQ) AND REQUEST FOR PROPOSAL (RFP)**

1. Awards will be made in the best interest of the State of West Virginia.
2. The State may accept or reject in part, or in whole, any bid.
3. All quotations are governed by the *West Virginia Code* and the *Legislative Rules* of the Purchasing Division.
4. Prior to any award, the apparent successful vendor must be properly registered with the Purchasing Division and have paid the required \$125.00 registration fee.
5. All services performed or goods delivered under State Purchase Orders/Contracts are to be continued for the term of the Purchase Order/Contract, contingent upon funds being appropriated by the Legislature or otherwise being made available. In the event funds are not appropriated or otherwise available for these services or goods, this Purchase Order/Contract becomes void and of no effect after June 30.
6. Payment may only be made after the delivery and acceptance of goods or services.
7. Interest may be paid for late payment in accordance with the *West Virginia Code*.
8. Vendor preference will be granted upon written request in accordance with the *West Virginia Code*.
9. The State of West Virginia is exempt from federal and state taxes and will not pay or reimburse such taxes.
10. The Director of Purchasing may cancel any Purchase Order/Contract upon 30 days written notice to the seller.
11. The laws of the State of West Virginia and the *Legislative Rules* of the Purchasing Division shall govern all rights and duties under the Contract, including without limitation the validity of this Purchase Order/Contract.
12. Any reference to automatic renewal is hereby deleted. The Contract may be renewed only upon mutual written agreement of the parties.
13. **BANKRUPTCY:** In the event the vendor/contractor files for bankruptcy protection, this Contract may be deemed null and void, and terminated without further order.
14. **HIPAA Business Associate Addendum -** The West Virginia State Government HIPAA Business Associate Addendum (BAA), approved by the Attorney General, and available online at the Purchasing Division's web site (<http://www.state.wv.us/admin/purchase/vrc/hipaa.htm>) is hereby made part of the agreement. Provided that, the Agency meets the definition of a Covered Entity (45 CFR §160.103) and will be disclosing Protected Health Information (45 CFR §160.103) to the vendor.

---

**INSTRUCTIONS TO BIDDERS**

1. Use the quotation forms provided by the Purchasing Division.
2. **SPECIFICATIONS:** Items offered must be in compliance with the specifications. Any deviation from the specifications must be clearly indicated by the bidder. Alternates offered by the bidder as **EQUAL** to the specifications must be clearly defined. A bidder offering an alternate should attach complete specifications and literature to the bid. The Purchasing Division may waive minor deviations to specifications.
3. Complete all sections of the quotation form.
4. Unit prices shall prevail in cases of discrepancy.
5. All quotations are considered F.O.B. destination unless alternate shipping terms are clearly identified in the quotation.
6. **BID SUBMISSION:** All quotations must be delivered by the bidder to the office listed below prior to the date and time of the bid opening. Failure of the bidder to deliver the quotations on time will result in bid disqualifications.

**SIGNED BID TO:**

Department of Administration  
Purchasing Division  
2019 Washington Street East  
Post Office Box 50130  
Charleston, WV 25305-0130



State of West Virginia  
 Department of Administration  
 Purchasing Division  
 2019 Washington Street East  
 Post Office Box 50130  
 Charleston, WV 25305-0130

# Request for Quotation

RFQ NUMBER:  
**DEFK8220**

PAGE:  
**2**

ADDRESS CORRESPONDENCE TO ATTENTION OF:  
**JOHN ABBOTT**  
**304-558-2544**

RFQ COPY  
 TYPE NAME/ADDRESS HERE

**DIV ENGINEERING & FACILITIES**  
**ARMORY BOARD SECTION**

**1707 COONSKIN DRIVE**  
**CHARLESTON, WV**  
**25311-1099 341-6368**

DATE PRINTED	TERMS OF SALE	SHIP VIA	FOB	FREIGHT TERMS
04/09/2008				

BID OPENING DATE: **05/15/2008** BID OPENING TIME **01:30PM**

LINE	QUANTITY	UOP	CAT NO	ITEM NUMBER	UNIT PRICE	AMOUNT
<p>THE HIGHER OF THE U.S. DEPARTMENT OF LABOR MINIMUM WAGE RATES AS ESTABLISHED FOR KANAWHA COUNTY, PURSUANT TO WEST VIRGINIA CODE 21-5A, ET, SEQ. (PREVAILING WAGE RATES APPLY TO THIS PROJECT)</p> <p>ARBITRATION: ANY REFERENCES MADE TO ARBITRATION OR INTEREST FOR PAYMENTS DUE (EXCEPT FOR ANY INTEREST REQUIRED BY STATE LAW) CONTAINED IN THIS CONTRACT OR IN ANY AMERICAN INSTITUTE OF ARCHITECTS DOCUMENTS PERTAINING TO THIS CONTRACT ARE HEREBY DELETED.</p> <p>WORKERS' COMPENSATION: VENDOR IS REQUIRED TO PROVIDE A CERTIFICATE FROM WORKERS' COMPENSATION IF SUCCESSFUL.</p> <p>ALL OF THE ITEMS CHECKED BELOW WILL BE A REQUIREMENT OF THIS CONTRACT:</p> <p>(XX) INSURANCE: SUCCESSFUL VENDOR SHALL FURNISH PROOF OF COMMERCIAL GENERAL LIABILITY INSURANCE PRIOR TO ISSUANCE OF CONTRACT. UNLESS OTHERWISE SPECIFIED IN THE BID DOCUMENTS, THE MINIMUM AMOUNT OF INSURANCE COVERAGE REQUIRED IS \$250,000.</p> <p>( ) BUILDERS RISK INSURANCE: SUCCESSFUL VENDOR SHALL FURNISH PROOF OF BUILDERS RISK - ALL RISK INSURANCE IN AN AMOUNT EQUAL TO 100% OF THE AMOUNT OF THE CONTRACT.</p> <p>(XX) BONDS: FIVE PERCENT (5%) OF THE TOTAL AMOUNT OF THE BID PAYABLE TO THE STATE OF WEST VIRGINIA, SHALL BE SUBMITTED WITH EACH BID AS A BID BOND. THE SUCCESSFUL BIDDER SHALL ALSO FURNISH A PERFORMANCE BOND AND LABOR/MATERIAL BOND FOR 100% OF THE AMOUNT OF THE CONTRACT. BONDS MAY BE PROVIDED IN THE FORM OF A CERTIFIED CHECK, IRREVOCABLE LETTER OF CREDIT, OR BOND FURNISHED BY A SOLVENT SURETY COMPANY AUTHORIZED TO DO BUSINESS IN THE STATE OF WEST VIRGINIA. A LETTER OF CREDIT SUBMITTED</p>						

SEE REVERSE SIDE FOR TERMS AND CONDITIONS

SIGNATURE <i>Ken K. Hoffmann, C.S.</i>	TELEPHONE 304-342-2721	DATE 5/22/2008
TITLE CORPORATE SECRETARY	FBN 55-0179050	ADDRESS CHANGES TO BE NOTED ABOVE

WHEN RESPONDING TO RFQ, INSERT NAME AND ADDRESS IN SPACE ABOVE LABELED 'VENDOR'



State of West Virginia  
 Department of Administration  
 Purchasing Division  
 2019 Washington Street East  
 Post Office Box 50130  
 Charleston, WV 25305-0130

# Request for Quotation

RFQ NUMBER  
**DEFK8220**

PAGE  
**3**

ADDRESS CORRESPONDENCE TO ATTENTION OF  
**JOHN ABBOTT**  
**304-558-2544**

RFQ COPY  
 TYPE NAME/ADDRESS HERE

**DIV ENGINEERING & FACILITIES**  
**ARMORY BOARD SECTION**

**1707 COONSKIN DRIVE**  
**CHARLESTON, WV**  
**25311-1099 341-6368**

DATE PRINTED	TERMS OF SALE	SHIP VIA	FOB	FREIGHT TERMS
04/09/2008				
BID OPENING DATE: 05/15/2008		BID OPENING TIME 01:30PM		

LINE	QUANTITY	UOP	CAT NO.	ITEM NUMBER	UNIT PRICE	AMOUNT
<p>IN LIEU OF A PERFORMANCE AND LABOR &amp; MATERIAL BOND WILL ONLY BE ALLOWED FOR PROJECTS UNDER \$100,000. PERSONAL OR BUSINESS CHECKS ARE NOT ACCEPTABLE IN LIEU OF THE 5% BID BOND, PERFORMANCE BOND, OR LABOR AND MATERIAL BOND.</p> <p>( ) MAINTENANCE BOND: A TWO (2) YEAR MAINTENANCE BOND COVERING THE ROOFING SYSTEM WILL BE A REQUIREMENT OF THE SUCCESSFUL VENDOR.</p> <p>REV. 11/00</p> <p>EXHIBIT 7</p> <p>DOMESTIC ALUMINUM, GLASS &amp; STEEL IN PUBLIC WORKS PROJECTS</p> <p>IN ACCORDANCE WITH WEST VIRGINIA CODE 5-19-1 ET., SEQ., EVERY CONTRACT FOR CONSTRUCTION, RECONSTRUCTION, ALTERATION, REPAIR, IMPROVEMENT OR MAINTENANCE OF PUBLIC WORKS, WHERE THE COST IS MORE THAN \$50,000 AND, IN THE CASE OF STEEL ONLY, WHERE THE COST OF STEEL IS MORE THAN \$50,000 OR WHERE MORE THAN 10,000 POUNDS OF STEEL ARE REQUIRED, THE STATE WILL ACCEPT ONLY ALUMINUM GLASS, OR STEEL PRODUCTS PRODUCED IN THE UNITED STATES. IN ADDITION, ITEMS OF MACHINERY OR EQUIPMENT PURCHASED FOR USE AT THE SITE OF PUBLIC WORKS SHALL BE MADE OF DOMESTIC ALUMINUM, GLASS OR STEEL, UNLESS THE COST OF THE PRODUCT IS LESS THAN \$50,000 OR LESS THAN 10,000 POUNDS OF STEEL ARE USED IN PUBLIC WORKS PROJECTS.</p> <p>FOREIGN MADE ALUMINUM, GLASS OR STEEL PRODUCTS MAY BE ACCEPTED ONLY IF THE COST OF DOMESTIC PRODUCTS IS FOUND TO BE UNREASONABLE. SUCH COST IS UNREASONABLE IF IT IS 20% OR MORE HIGHER THAN THE BID PRICE FOR FOREIGN MADE</p>						

SEE REVERSE SIDE FOR TERMS AND CONDITIONS

SIGNATURE <i>Ron K. Hoffman, C.S.</i>	TELEPHONE 304-342-2721	DATE 5/22/08
TITLE CORPORATE SECRETARY	FEIN 55-0179050	ADDRESS CHANGES TO BE NOTED ABOVE

WHEN RESPONDING TO RFQ, INSERT NAME AND ADDRESS IN SPACE ABOVE LABELED 'VENDOR'



State of West Virginia  
 Department of Administration  
 Purchasing Division  
 2019 Washington Street East  
 Post Office Box 50130  
 Charleston, WV 25305-0130

# Request for Quotation

RFQ NUMBER  
**DEFK8220**

PAGE  
**4**

ADDRESS CORRESPONDENCE TO ATTENTION OF  
**JOHN ABBOTT**  
**304-558-2544**

RFQ COPY  
 TYPE NAME/ADDRESS HERE

**DIV ENGINEERING & FACILITIES**  
**ARMORY BOARD SECTION**

**1707 COONSKIN DRIVE**  
**CHARLESTON, WV**  
**25311-1099 341-6368**

DATE PRINTED	TERMS OF SALE	SHIP VIA	FOB	FREIGHT TERMS
04/09/2008				

BID OPENING DATE: **05/15/2008** BID OPENING TIME **01:30PM**

LINE	QUANTITY	UCP	CAT NO.	ITEM NUMBER	UNIT PRICE	AMOUNT
<p>PRODUCTS. IF THE DOMESTIC ALUMINUM, GLASS OR STEEL PRODUCTS TO BE SUPPLIED OR PRODUCED IN A "SUBSTANTIAL LABOR SURPLUS AREA", AS DEFINED BY THE UNITED STATES DEPARTMENT OF LABOR, FOREIGN PRODUCTS MAY BE SUPPLIED ONLY IF DOMESTIC PRODUCTS ARE 30% OR MORE HIGHER IN PRICE THAN THE FOREIGN MADE PRODUCTS.</p> <p>IF, PRIOR TO THE AWARD OF A CONTRACT UNDER THE ABOVE PROVISIONS, THE SPENDING OFFICER OF THE SPENDING UNIT DETERMINES THAT THERE EXISTS A BID FOR LIKE FOREIGN ALUMINUM, GLASS OR STEEL THAT IS REASONABLE AND LOWER THAN THE LOWEST BID DOMESTIC PRODUCTS, THE SPENDING OFFICE MAY REQUEST, IN WRITING, A REEVALUATION AND REDUCTION IN THE LOWEST BID FOR SUCH DOMESTIC PRODUCTS. ALL VENDORS MUST INDICATE IN THEIR BID IF THEY ARE SUPPLYING FOREIGN ALUMINUM, GLASS OR STEEL.</p> <p>REV. 3/88</p> <p>EXHIBIT 9</p> <p>NOTICE FOR ISSUANCE &amp; ACKNOWLEDGEMENT OF CONSTRUCTION PROJECT ADDENDA</p> <p>THE ARCHITECT/ENGINEER AND/OR AGENCY SHALL BE REQUIRED TO ABIDE BY THE FOLLOWING SCHEDULE IN ISSUING CONSTRUCTION PROJECT ADDENDA FOR STATE AGENCIES:</p> <p>(1) THE ARCHITECT/ENGINEER SHALL PREPARE THE ADDENDUM AND A LIST OF ALL PARTIES THAT HAVE PROCURED DRAWINGS AND SPECIFICATIONS FOR THE PROJECT. THE ADDENDUM AND LIST SHALL BE FORWARDED TO THE BUYER IN THE STATE PURCHASING DIVISION. THE ARCHITECT/ENGINEER SHALL ALSO SEND A COPY OF THE ADDENDUM TO THE STATE AGENCY FOR WHICH THE CONTRACT IS ISSUED.</p>						

SEE REVERSE SIDE FOR TERMS AND CONDITIONS

SIGNATURE <i>Ron K. Hoffman, C.S.</i>	TELEPHONE 304-342-2721	DATE 5/22/2008
TITLE CORPORATE SECRETARY	FEIN 55-0179050	ADDRESS CHANGES TO BE NOTED ABOVE

WHEN RESPONDING TO RFQ, INSERT NAME AND ADDRESS IN SPACE ABOVE LABELED 'VENDOR'



State of West Virginia  
 Department of Administration  
 Purchasing Division  
 2019 Washington Street East  
 Post Office Box 50130  
 Charleston, WV 25305-0130

**Request for Quotation**

RFQ NUMBER  
**DEFK8220**

PAGE  
**5**

ADDRESS CORRESPONDENCE TO ATTENTION OF  
**JOHN ABBOTT  
 304-558-2544**

RFQ COPY  
 TYPE NAME/ADDRESS HERE

PURCHASING

SHIP TO

**DIV ENGINEERING & FACILITIES  
 ARMORY BOARD SECTION  
 1707 COONSKIN DRIVE  
 CHARLESTON, WV  
 25311-1099 341-6368**

DATE PRINTED <b>04/09/2008</b>	TERMS OF SALE	SHIP VIA	FOB	FREIGHT TERMS
-----------------------------------	---------------	----------	-----	---------------

BID OPENING DATE: **05/15/2008** BID OPENING TIME **01:30PM**

LINE	QUANTITY	UOP	CAT NO	ITEM NUMBER	UNIT PRICE	AMOUNT
<p>(2) THE BUYER SHALL SEND THE ADDENDUM TO ALL INTERESTED PARTIES AND, IF NECESSARY, EXTEND THE BID OPENING DATE. ANY ADDENDUM SHOULD BE RECEIVED BY THE BUYER WITHIN FOURTEEN (14) DAYS PRIOR TO THE BID OPENING DATE.</p> <p>(3) ALL ADDENDA SHOULD BE FORMALLY ACKNOWLEDGED BY ALL BIDDERS AND SUBMITTED TO THE STATE PURCHASING DIVISION. THE SAME RULES AND REGULATIONS THAT APPLY TO THE ORIGINAL BIDDING DOCUMENT SHALL ALSO APPLY TO AN ADDENDUM DOCUMENT. THE ONLY EXCEPTION MAY BE FOR AN ADDENDUM THAT IS ISSUED FOR THE SOLE PURPOSE OF CHANGING A BID OPENING TIME AND/OR DATE.</p> <p>REV. 11/96</p> <p>EXHIBIT 10</p> <p>ADDENDUM ACKNOWLEDGEMENT</p> <p>I HEREBY ACKNOWLEDGE RECEIPT OF THE FOLLOWING CHECKED ADDENDUM(S) AND HAVE MADE THE NECESSARY REVISIONS TO MY PROPOSAL, PLANS AND/OR SPECIFICATION, ETC.</p> <p>ADDENDUM NOS.:</p> <p>NO. 1 ..... ✓</p> <p>NO. 2 ..... ✓</p> <p>NO. 3 ..... </p> <p>NO. 4 ..... </p>						

SEE REVERSE SIDE FOR TERMS AND CONDITIONS

SIGNATURE <i>Ron K. Hoffman, C.S.</i>	TELEPHONE <i>304-342-2721</i>	DATE <i>5/22/2008</i>
TITLE <i>CORPORATE SECRETARY</i>	FEBN <i>55-0179050</i>	ADDRESS CHANGES TO BE NOTED ABOVE

WHEN RESPONDING TO RFQ, INSERT NAME AND ADDRESS IN SPACE ABOVE LABELED 'VENDOR'



State of West Virginia  
 Department of Administration  
 Purchasing Division  
 2019 Washington Street East  
 Post Office Box 50130  
 Charleston, WV 25305-0130

# Request for Quotation

RFQ NUMBER  
**DEFK8220**

PAGE  
**6**

ADDRESS CORRESPONDENCE TO ATTENTION OF  
**JOHN ABBOTT**  
**304-558-2544**

RFQ COPY

TYPE NAME/ADDRESS HERE

SHIP TO

DIV ENGINEERING & FACILITIES  
 ARMORY BOARD SECTION  
  
 1707 COONSKIN DRIVE  
 CHARLESTON, WV  
 25311-1099 341-6368

DATE PRINTED	TERMS OF SALE	SHIP VIA	F.O.B.	FREIGHT TERMS
04/09/2008				

BID OPENING DATE: **05/15/2008** BID OPENING TIME **01:30PM**

LINE	QUANTITY	UOP	CAT NO	ITEM NUMBER	UNIT PRICE	AMOUNT
NO. 5						
<p>I UNDERSTAND THAT FAILURE TO CONFIRM THE RECEIPT OF THE ADDENDUM(S) MAY BE CAUSE FOR REJECTION OF THE BIDS.</p> <p>VENDOR MUST CLEARLY UNDERSTAND THAT ANY VERBAL REPRESENTATION MADE OR ASSUMED TO BE MADE DURING ANY ORAL DISCUSSION HELD BETWEEN VENDOR'S REPRESENTATIVES AND ANY STATE PERSONNEL IS NOT BINDING. ONLY THE INFORMATION ISSUED IN WRITING AND ADDED TO THE SPECIFICATIONS BY AN OFFICIAL ADDENDUM IS BINDING.</p> <p>.....<i>Ron K. Hoffman</i>.....SIGNATURE            .....<i>GLEM COMPANY</i>.....COMPANY            .....<i>5/22/2008</i>.....DATE</p> <p>REV. 11/96</p> <p>CONTRACTORS LICENSE</p> <p>WEST VIRGINIA STATE CODE 21-11-2 REQUIRES THAT ALL PERSONS DESIRING TO PERFORM CONTRACTING WORK IN THIS STATE MUST BE LICENSED. THE WEST VIRGINIA CONTRACTORS LICENSING BOARD IS EMPOWERED TO ISSUE THE CONTRACTORS LICENSE. APPLICATIONS FOR A CONTRACTORS LICENSE MAY B MADE BY CONTACTING THE WEST VIRGINIA DIVISION OF LABOR CAPITOL COMPLEX, BUILDING 3, ROOM 319, CHARLESTON, WV 25305. TELEPHONE: (304) 558-7890.</p> <p>WEST VIRGINIA STATE CODE 21-11-11 REQUIRES ANY PROSPECTIVE BIDDER TO INCLUDE THE CONTRACTORS</p>						

SEE REVERSE SIDE FOR TERMS AND CONDITIONS

SIGNATURE <i>Ron K. Hoffman, C.S.</i>	TELEPHONE <i>304-342-2721</i>	DATE <i>5/22/2008</i>
TITLE <i>CORPORATE SECRETARY</i>	FEIN <i>55-0179050</i>	ADDRESS CHANGES TO BE NOTED ABOVE

WHEN RESPONDING TO RFQ, INSERT NAME AND ADDRESS IN SPACE ABOVE LABELED 'VENDOR'



State of West Virginia  
 Department of Administration  
 Purchasing Division  
 2019 Washington Street East  
 Post Office Box 50130  
 Charleston, WV 25305-0130

# Request for Quotation

RFQ NUMBER  
**DEFK8220**

PAGE  
**7**

ADDRESS CORRESPONDENCE TO ATTENTION OF  
**JOHN ABBOTT  
 304-558-2544**

VENDOR

RFQ COPY  
 TYPE NAME/ADDRESS HERE

SHIP TO

DIV ENGINEERING & FACILITIES  
 ARMORY BOARD SECTION  
 1707 COONSKIN DRIVE  
 CHARLESTON, WV  
 25311-1099 341-6368

DATE PRINTED	TERMS OF SALE	SHIP VIA	FOB	FREIGHT TERMS
04/09/2008				

BID OPENING DATE: **05/15/2008** BID OPENING TIME **01:30PM**

LINE	QUANTITY	UOP	CAT NO	ITEM NUMBER	UNIT PRICE	AMOUNT
<p>LICENSE NUMBER ON THEIR BID.</p> <p>BIDDER TO COMPLETE:</p> <p>CONTRACTORS NAME: ..... <i>GLEM COMPANY</i> .....</p> <p>CONTRACTORS LICENSE NO.: ..... <i>WV001795</i> .....</p> <p>THE SUCCESSFUL BIDDER WILL BE REQUIRED TO FURNISH A COPY OF THEIR CONTRACTORS LICENSE PRIOR TO ISSUANCE OF A PURCHASE ORDER/CONTRACT</p> <p>APPLICABLE LAW</p> <p>THE WEST VIRGINIA STATE CODE, PURCHASING DIVISION RULES AND REGULATIONS, AND THE INFORMATION PROVIDED IN THE "REQUEST FOR QUOTATION" ISSUED BY THE PURCHASING DIVISION IS THE SOLE AUTHORITY GOVERNING THIS PROCUREMENT.</p> <p>ANY INFORMATION PROVIDED IN SPECIFICATION MANUALS, OR ANY OTHER SOURCE, VERBAL OR WRITTEN, WHICH CONTRADICTS OR ALTERS THE INFORMATION PROVIDED FROM THE SOURCES AS DESCRIBED IN THE ABOVE PARAGRAPH IS VOID AND OF NO EFFECT.</p> <p>BANKRUPTCY: IN THE EVENT THE VENDOR/CONTRACTOR FILES FOR BANKRUPTCY PROTECTION, THIS CONTRACT IS AUTOMATICALLY NULL AND VOID, AND IS TERMINATED WITHOUT FURTHER ORDER.</p> <p>REV. 1/2005</p> <p>NOTICE</p>						

SEE REVERSE SIDE FOR TERMS AND CONDITIONS

SIGNATURE <i>Ron K. Hoffmann, C.S.</i>	TELEPHONE <i>304-342-2721</i>	DATE <i>5/22/2008</i>
TITLE <i>CORPORATE SECRETARY</i>	FEN <i>55-0179050</i>	ADDRESS CHANGES TO BE NOTED ABOVE

WHEN RESPONDING TO RFQ, INSERT NAME AND ADDRESS IN SPACE ABOVE LABELED 'VENDOR'





State of West Virginia  
 Department of Administration  
 Purchasing Division  
 2019 Washington Street East  
 Post Office Box 50130  
 Charleston, WV 25305-0130

### Request for Quotation

RFQ NUMBER  
**DEFK8220**

PAGE  
**8**

ADDRESS CORRESPONDENCE TO ATTENTION OF  
**JOHN ABBOTT**  
**304-558-2544**

RFQ COPY  
 TYPE NAME/ADDRESS HERE

**DIV ENGINEERING & FACILITIES**  
**ARMORY BOARD SECTION**

**1707 COONSKIN DRIVE**  
**CHARLESTON, WV**  
**25311-1099 341-6368**

DATE PRINTED	TERMS OF SALE	SHIP VIA	FOB	FREIGHT TERMS
04/09/2008				
BID OPENING DATE: 05/15/2008		BID OPENING TIME 01:30PM		

LINE	QUANTITY	UOP	CAT NO	ITEM NUMBER	UNIT PRICE	AMOUNT
<p><b>A SIGNED BID MUST BE SUBMITTED TO:</b></p> <p>DEPARTMENT OF ADMINISTRATION            PURCHASING DIVISION            BUILDING 15            2019 WASHINGTON STREET, EAST            CHARLESTON, WV 25305-0130</p> <p><b>THE BID SHOULD CONTAIN THIS INFORMATION ON THE FACE OF THE ENVELOPE OR THE BID MAY NOT BE CONSIDERED:</b></p> <p>SEALED BID</p> <p>BUYER: JOHN ABBOTT-----</p> <p>REQ. NO.: DEFK8220-----</p> <p>BID OPENING DATE: 05/15/2008-----</p> <p>BID OPENING TIME: 1:30 PM-----</p> <p>PLEASE PROVIDE A FAX NUMBER IN CASE IT IS NECESSARY TO CONTACT YOU REGARDING YOUR BID:            -----  <i>304-344-0833</i></p> <p>PLEASE PRINT OR TYPE NAME OF PERSON TO CONTACT CONCERNING THIS QUOTE:            -----  <i>RON K. HOFFMAN</i></p>						

SEE REVERSE SIDE FOR TERMS AND CONDITIONS

SIGNATURE <i>Ron K. Hoffman, C.S.</i>	TELEPHONE <i>304-342-2721</i>	DATE <i>5/22/2008</i>
TITLE <i>CORPORATE SECRETARY</i>	FEIN <i>55-0179050</i>	ADDRESS CHANGES TO BE NOTED ABOVE

WHEN RESPONDING TO RFQ, INSERT NAME AND ADDRESS IN SPACE ABOVE LABELED 'VENDOR'



State of West Virginia  
 Department of Administration  
 Purchasing Division  
 2019 Washington Street East  
 Post Office Box 50130  
 Charleston, WV 25305-0130

# Request for Quotation

RFQ NUMBER  
**DEFK8220**

PAGE  
**9**

ADDRESS CORRESPONDENCE TO ATTENTION OF  
**JOHN ABBOTT**  
**304-558-2544**

RFQ COPY  
 TYPE NAME/ADDRESS HERE

VENDOR

SHIP TO

**DIV ENGINEERING & FACILITIES**  
**ARMORY BOARD SECTION**

**1707 COONSKIN DRIVE**  
**CHARLESTON, WV**  
**25311-1099 341-6368**

DATE PRINTED	TERMS OF SALE	SHIP VIA	FOB	FREIGHT TERMS
04/09/2008				

BID OPENING DATE: **05/15/2008** BID OPENING TIME **01:30PM**

LINE	QUANTITY	UOP	CAT NO	ITEM NUMBER	UNIT PRICE	AMOUNT
***** THIS IS THE END OF RFQ DEFK8220 ***** TOTAL:						<u>63,000.<sup>00</sup></u>

SEE REVERSE SIDE FOR TERMS AND CONDITIONS

SIGNATURE <i>Kon K. Hojman, C.S.</i>	TELEPHONE 304-342-2721	DATE 5/22/2008
TITLE CORPORATE SECRETARY	FEIN 55-0179050	ADDRESS CHANGES TO BE NOTED ABOVE

WHEN RESPONDING TO RFQ, INSERT NAME AND ADDRESS IN SPACE ABOVE LABELED 'VENDOR'

A. Site: The attached schematic is an approximation provided for general information (See Attachment 1). The awarded contractor will be responsible for field measuring all distances and surveyor support as needed. These specifications include reference to Standard Technical Design (STD) Number 872-90-15 from the Omaha Nebraska District of the US Army Corps of Engineer and dated 03/17/2004 which is provided as attachment 2 and excerpted below for convenience; the STD has precedence if a conflict exists.

B. Cables shall be continuous from deadman to deadman. No splices in cable shall be allowed. Cable barrier shall be US domestic  $\frac{3}{4}$  inch 6X19 class wire rope, regular lay, extra improved plow steel (EIPS), independent wire rope core (IWRC), Class A galvanized, in accordance with (IAW) ASTM F1145. Wire rope clamps shall be Type 1, Class 1, galvanized, IAW FS FF-C-450.

C. U-bolts on line posts shall be installed perpendicular to the strand of the wire rope and shall be tightened after sag in cable barrier has been removed. U-bolts and hex nuts shall be  $\frac{1}{2}$  inch galvanized IAW ASTM A307 and ASTM A563.

D. Brace panels with deadmen shall be spaced at 200 foot maximum interval and at changes in alignment exceeding 45 degrees. Threaded rods shall be 1 -  $\frac{1}{4}$  inch galvanized IAW ASTM A307 or A36. Welded brace rails shall be installed as per the plans and AWS D1.1 (structural welding code - steel) at corner, end, gate, and pull posts. Damage to galvanized surface shall be repair IAW AWS WZC.

E. The contractor is responsible for coordinating for material storage which is limited at this site.

F. The contractor may need to coordinate with the County for traffic control on Coonskin Drive due to constrained workspace.

G. The contractor will seed, fertilize, and mulch all disturbed areas and will submit fertilizer and seed content for approval prior to application.

## CONTINUATION PAGE TWO

H Pre-bid Location: The mandatory prebid conference will be conducted on the date specified above at the Drill Hall, WV Army National Guard Complex, 1703 Coonskin Drive, Charleston, WV. The Drill Hall is the first brick building on the left after going by the Air National Guard. park is available in Visitor's Parking and entry is through the glass doors on the end of the building under the overhang.

I. Liquidated Damages: Liquidated damages shall be imposed at the rate of \$1,345.13 per day each day after failing to meet the contracted completion date. This clause shall in no way be considered exclusive and shall not limit the State or Agency's right to pursue to any other additional remedy to which the State or Agency may have legal cause for action including further damages against the Vendor.

J. The contractor is responsible for developing and submitting runoff and erosion control measures or permits as necessary.

K. Award of a contract for this project is based upon availability of funding.

L. Access to the construction area will be restricted and controlled by the Contractor.

M. Cleanup is required daily. No open dumps of construction materials. Remove surplus soil material, unsuitable topsoil, obstructions, demolished materials, and waste materials including trash and debris, and legally dispose of them off Owner's property. Consideration will be given to relocating crushed pavement, gravel and clean soil on the property with the owner's permission.

N. Contractor is responsible for keeping driveways and entrances serving the premises clear and available for the Owner's use.

O. Repair to damaged structures, contents, and surrounding grounds will be the contractor's responsibility.

P. The contractor shall not use WVARNG facilities without prior approval; this includes dumpsters, restrooms, phones, or utilities.

Q. Contractor shall coordinate storage of materials and equipment park locations with the WVARNG.

R. All personnel shall carry an ID such as a driver's license while working on or around the premises.

S. All work will be supervised. The WVARNG will be provided the name of the on-site person in charge with a means of immediate contact.

T. The contractor is responsible for paying current and applicable prevailing wage rates and providing certified payrolls as directed.

U. Prior to initiation of work, the contractor shall meet with the WVARNG to coordinate the design intent, construction coordination, and deliverable products. Contractors will provide weekly updates to the WVARNG.

V. Prior arrangements must be made to work outside work hours. Normal work hours for this location are 7:30 am to 4:00 pm Monday – Friday.

W. It is the designated contractor's responsibility to conduct all activities in a manner that ensures the safety of crewmembers and avoids damage to vehicles and property of the WVARNG.

Bid:

Base Bid:

Install 1,850' Installed Double Cable Barrier represented as Segments 1-6 & 8-20: \$ 63,000.00

ADD/ALT: Install 125' Double Cable Barrier represented as Segment 7: \$ 63,000.00

## GENERAL NOTES:

1. CABLES SHALL BE CONTINUOUS FROM DEADMAN TO DEADMAN. NO SPLICES IN CABLE SHALL BE ALLOWED. CABLE BARRIER SHALL BE INSTALLED BETWEEN FENCE POSTS AND FENCE FABRIC AS PER PLANS. U-BOLTS ON LINE POSTS SHALL BE INSTALLED PERPENDICULAR TO THE STRANDS OF THE WIRE ROPE AND SHALL BE TIGHTENED AFTER SAG IN CABLE BARRIER HAS BEEN REMOVED. BRACE PANELS W/DEADMEN SHALL BE SPACED AT 200 FOOT MAXIMUM INTERVALS AND AT CHANGES IN ALIGNMENT EXCEEDING 45 DEGREES. DEADMAN SPACING IS BASED ON A SPECIFIC VEHICLE WITH A RESULTANT KINETIC ENERGY OF LESS THAN 400 K FOOT POUNDS. FOR LONGER DEADMAN RUNS AN ANALYSIS WILL HAVE TO BE MADE TO DETERMINE EFFECTIVENESS FOR ACCEPTABLE PENETRATION LIMITS.
2. CABLE BARRIER SHALL BE U.S. DOMESTIC 3/4 INCH 6x19 CLASS WIRE ROPE, REGULAR LAY, EXTRA IMPROVED PLOW STEEL (EIPS), INDEPENDENT WIRE ROPE CORE, (IWRC), CLASS A GALVANIZED, IN ACCORDANCE WITH ASTM A1023/A1023M
3. EYE TO EYE TURNBUCKLES SHALL BE 1-1/4" X 12", TYPE I; FORM 1 CLASS 4 ZINC COATED, IN ACCORDANCE WITH ASTM F1145.
4. WIRE ROPE CLAMPS SHALL BE TYPE I, CLASS 1, GALVANIZED, IN ACCORDANCE WITH FS FF-C-450
5. U-BOLTS AND HEX NUTS SHALL BE 1/2", GALVANIZED; IN ACCORDANCE WITH ASTM A307 AND ASTM A563.
6. THREADED RODS SHALL BE 1-1/4", GALVANIZED, IN ACCORDANCE WITH ASTM A307 OR A36.
7. WELDED BRACE RAILS SHALL BE INSTALLED AS PER THE PLANS AND AWS D1.1 (STRUCTURAL WELDING CODE - STEEL) AT CORNER, END, GATE, AND PULL POSTS. DAMAGE TO THE GALVANIZED SURFACE DUE TO WELDING SHALL BE REPAIRED WITH "REPAIR STICKS" OF ZINC-CADMIUM ALLOYS OR ZINC-TIN LEAD ALLOYS AS PER AWS WZC.
8. FOR EXISTING FENCES, REPLACE THE LINE POSTS AT THE BEGINNING AND END OF EVERY CABLE RUN WITH A 4" ANCHOR POST AND 4" PULL POST.

9. DEADMAN OFFSET IS PROVIDED TO ALLOW ACCESS TO TURNBUCKLES FOR FUTURE ADJUSTMENT AFTER FENCE FABRIC IS INSTALLED. IF FENCE FABRIC IS NOT TO BE INSTALLED ON THE BARRIER POSTS, OFFSET MAY BE ELIMINATED AS APPROVED.

10. WHEN FENCE FABRIC IS NOT TO BE INSTALLED, PROVIDE POSTS AND FITTINGS IN CONFORMANCE WITH DETAILS SHOWN ON THIS SHEET AND THE REQUIREMENTS FOR FENCE TYPE FE5.

WV ARMY NATIONAL GUARD BARRIER PLAN  
COONSKIN DRIVE, CHARLESTON, WV 25311

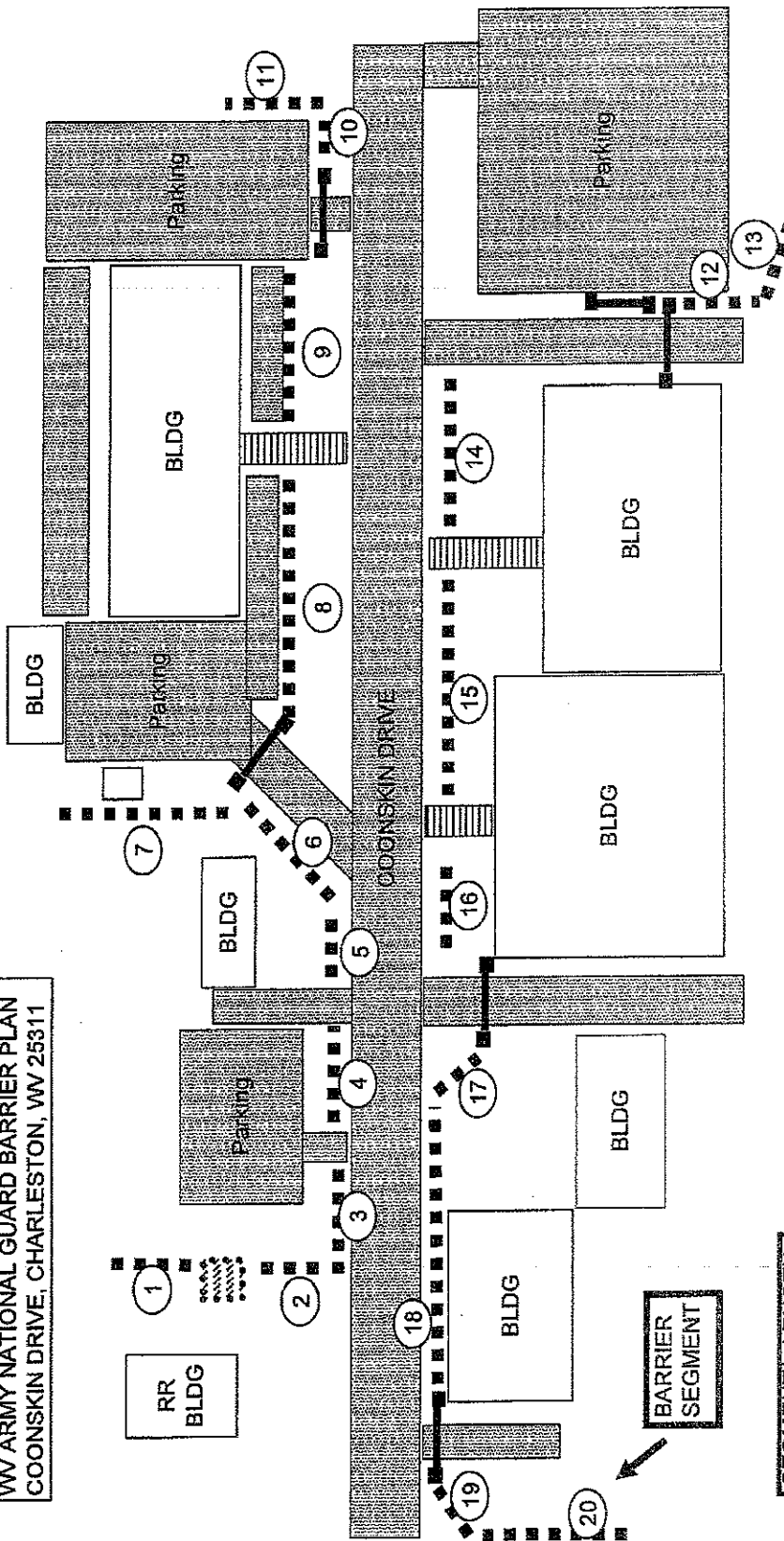

SEGMENT	LENGTH
1	40
2	20
3	15
4	20
5	100
6	110
7	125
8	320

SEGMENT	LENGTH
9	200
10	26
11	100
12	20
13	75
14	140
15	160

SEGMENT	LENGTH
16	110
17	40
18	200
19	50
20	100

TOTAL	1971
-------	------



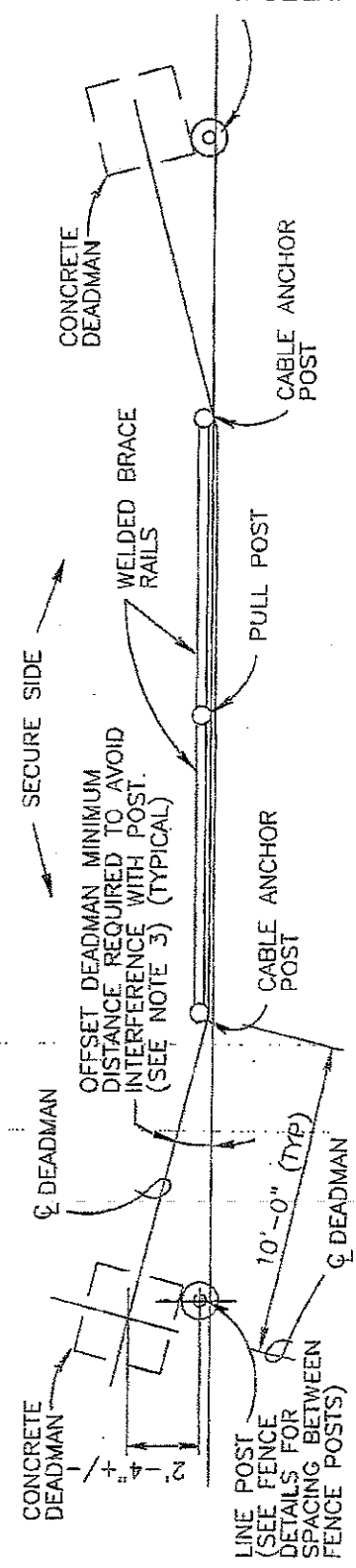
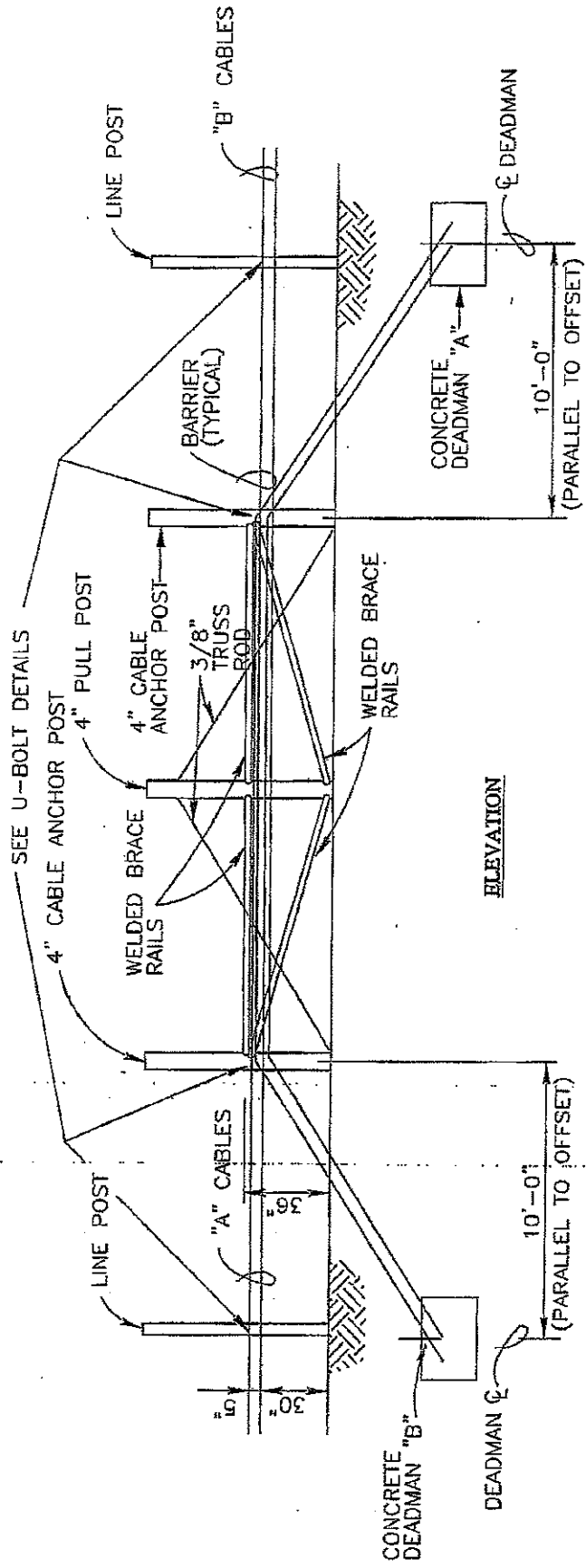

LINE POST (SEE FENCE DETAILS FOR SPACING BETWEEN FENCE POSTS)

LINE POST (SEE FENCE DETAILS FOR SPACING BETWEEN FENCE POSTS)

**NOTES:**

1. FENCE FABRIC NOT SHOWN FOR CLARITY.
2. CABLE 'A' & 'B' DESIGNATIONS ARE FOR CLARIFICATION OF ROUTING OF CABLES.
3. DEADMAN OFFSET MAY BE ELIMINATED WHEN FENCE FABRIC IS NOT TO BE INSTALLED ON CABLE BARRIER POSTS. SEE GENERAL NOTE 9, THIS SHEET.

2

**BRACE PANEL W/ DEADMEN DETAIL**

NO SCALE

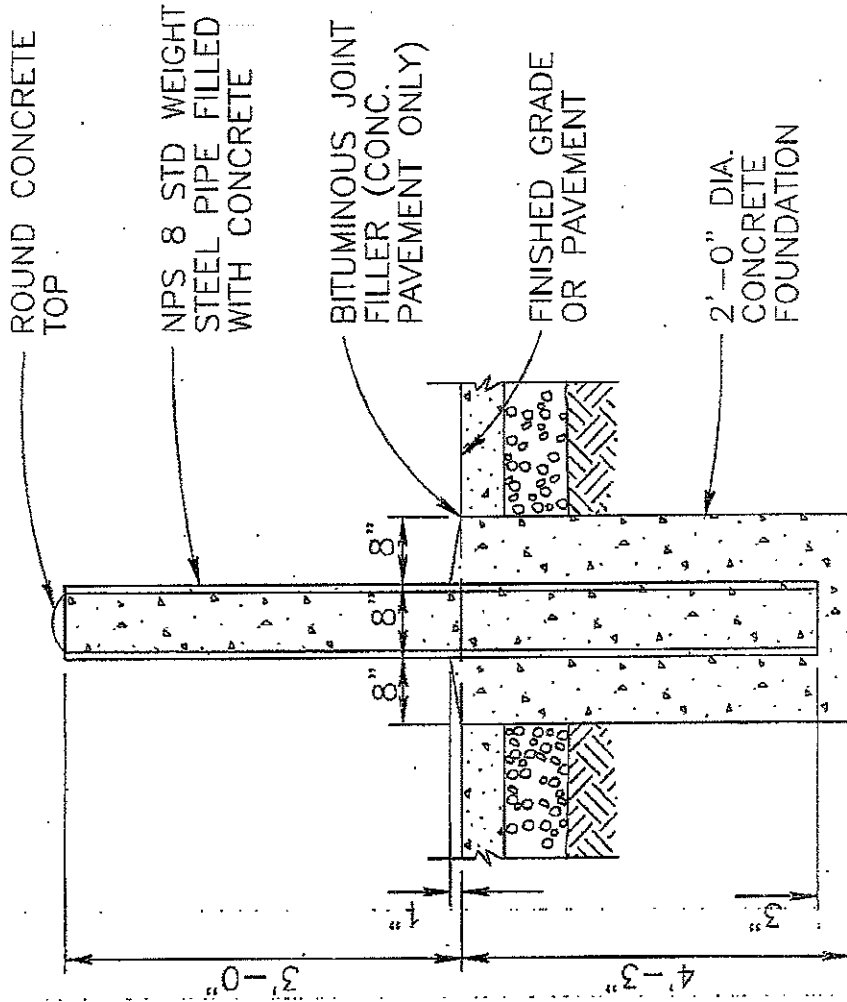

**4 3 1 PIPE GUARD DETAIL**

NO SCALE

**NOTE:**

STEEL PIPE FOR PIPE GUARDS SHALL CONFORM TO ASTM A53, TYPE E OR S, GRADE B GALVANIZED, MINIMUM WALL THICKNESS 0.322 INCHES.

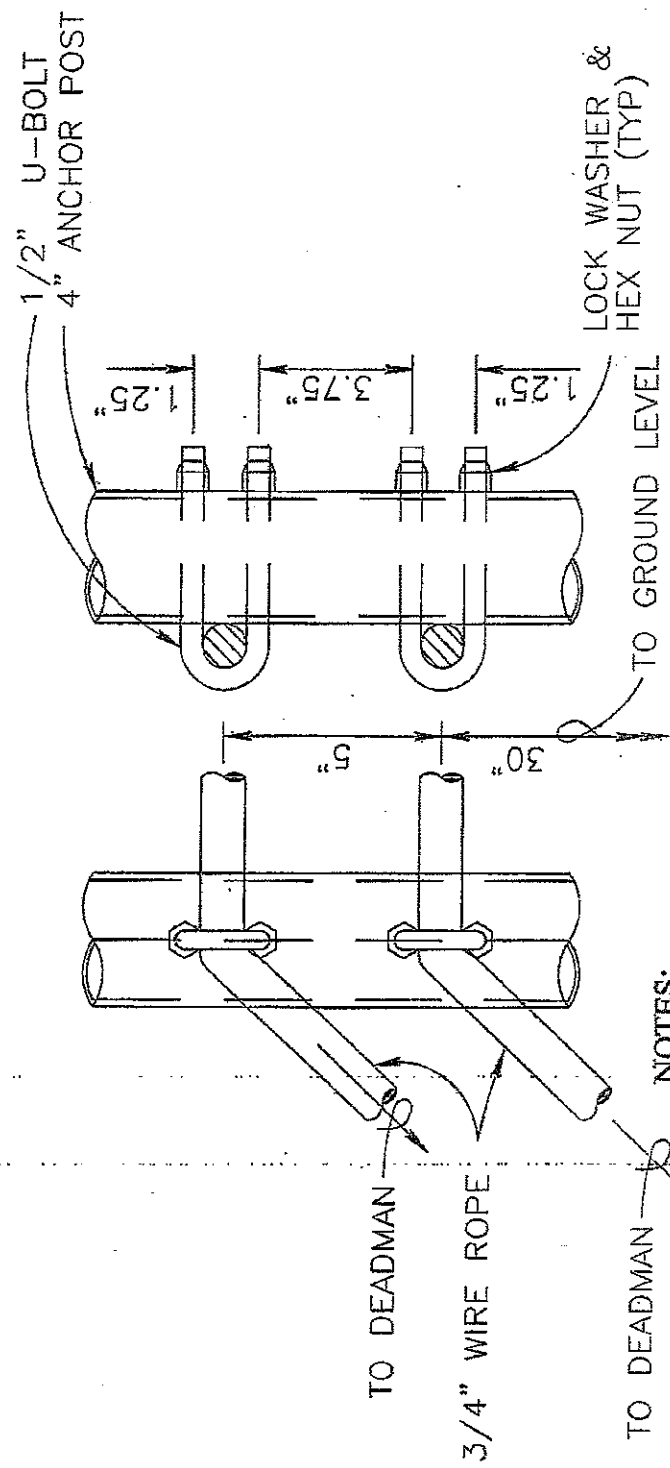

**NOTES:**

1. WHERE "A" AND "B" CABLES OVERLAP, USE U-BOLT AT OVERLAPPING CABLES DETAIL.
2. WIRE ROPE CLAMP NOT SHOWN.
3. VERIFY ASSEMBLY BEFORE ORDERING/FABRICATING.

②

**U-BOLT AT CABLE ANCHOR POST DETAIL**

NO SCALE

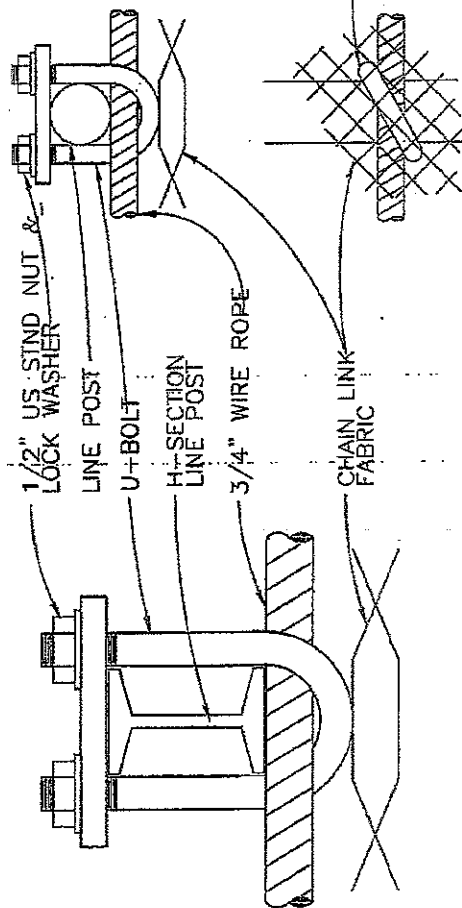

ROUND POSTS: POST O.D. + 0.875"  
H=POSTS: 3.00

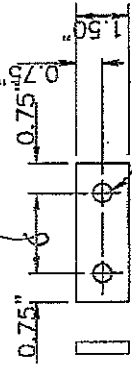

0.563" HOLE (TYP.)  
1/2" -UNC-2A  
STEEL

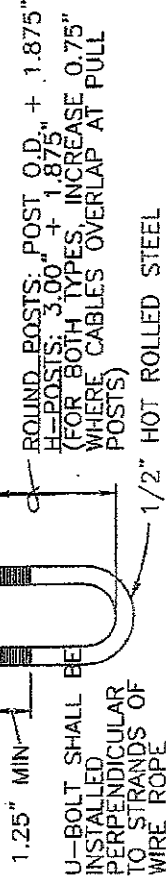

1.25" MIN  
U-BOLT SHALL BE  
INSTALLED  
PERPENDICULAR  
TO STRANDS OF  
WIRE ROPE

ROUND POSTS: POST O.D. + 1.875"  
H=POSTS: 3.00 + 1.875"  
(FOR BOTH TYPES, INCREASE 0.75"  
WHERE CABLES OVERLAP AT PULL  
POSTS)

1/2" HOT ROLLED STEEL

② U-BOLT AT LINE POST DETAILS  
NO SCALE

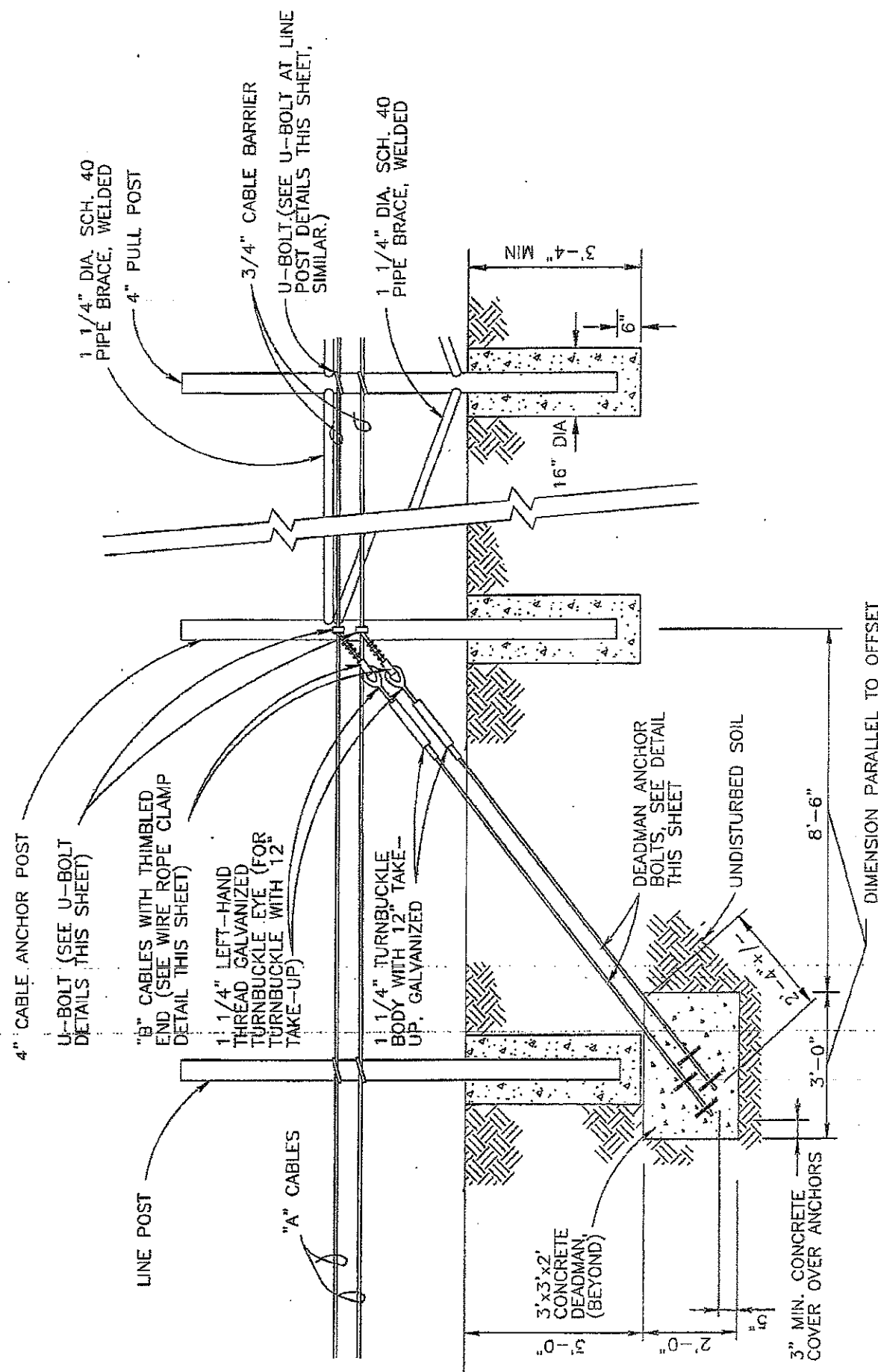

NOTE:  
FENCE FABRIC NOT SHOWN  
FOR CLARITY

DEADMAN DETAIL  
NO SCALE

1

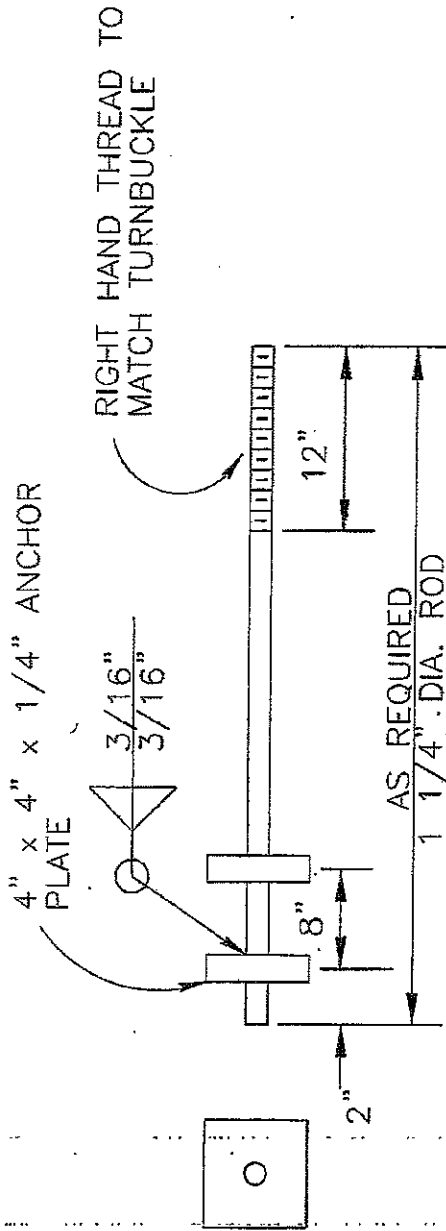

**NOTE:**

HOT DIP GALVANIZE ANCHOR ASSEMBLY AFTER FABRICATION.

**② DEADMAN ANCHOR BOLT DETAIL**

NO SCALE

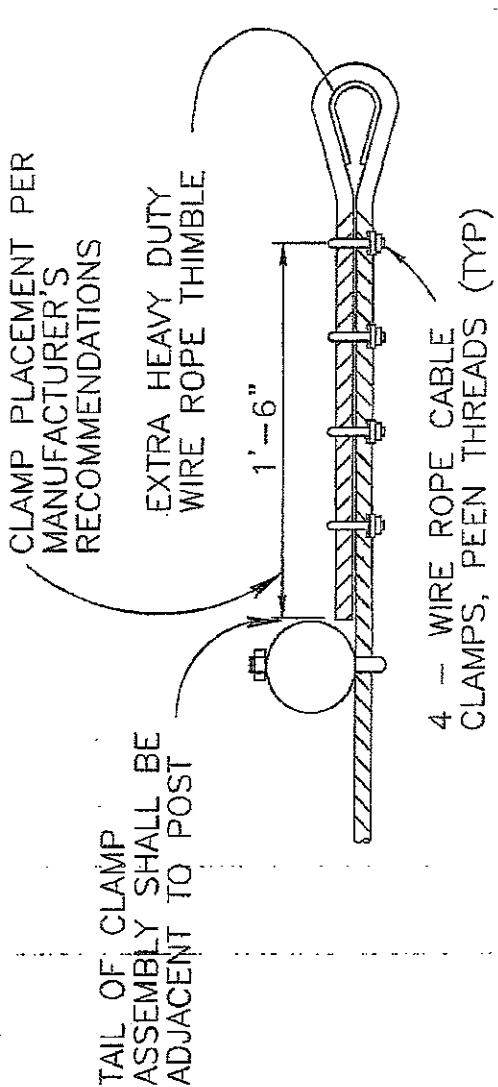

① WIRE ROPE CLAMP DETAIL  
NO SCALE

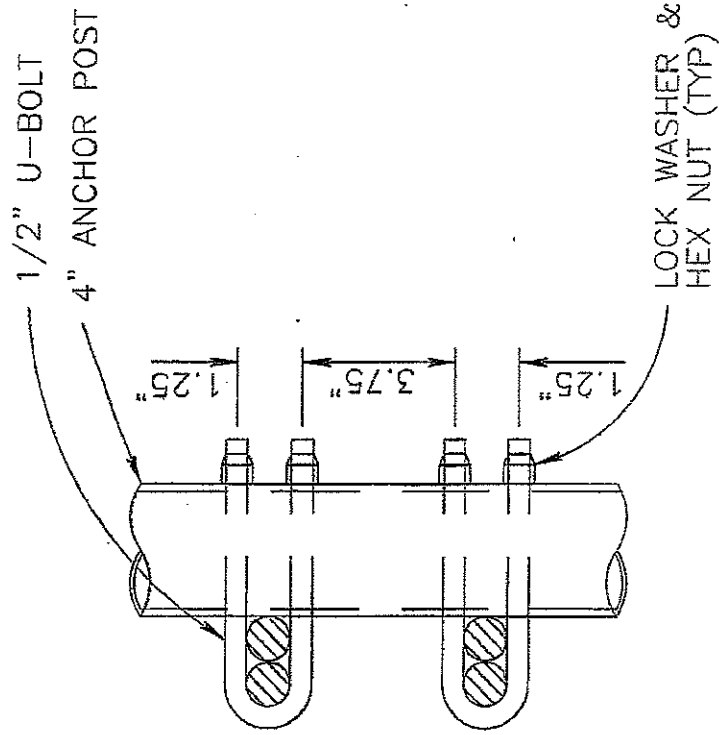

**① U-BOLT AT OVERLAPPING CABLES DETAIL**

NO SCALE



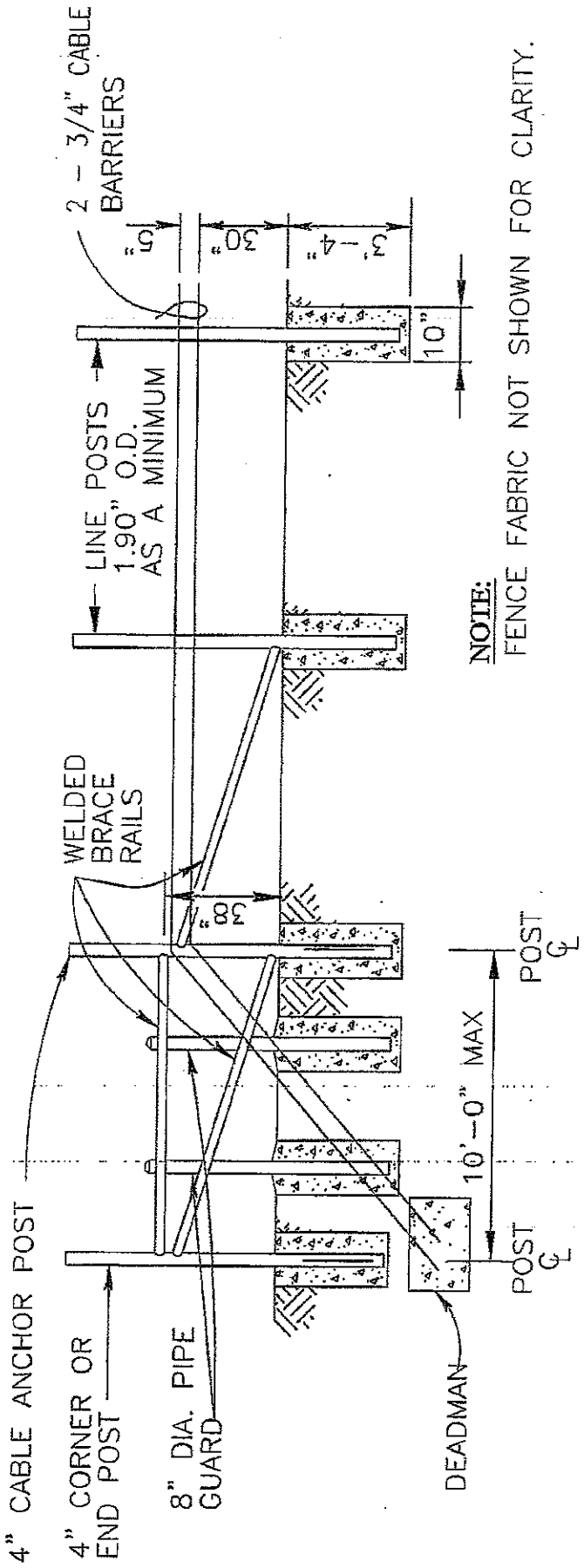

NOTE:  
 FENCE FABRIC NOT SHOWN FOR CLARITY.

**END PANEL ELEVATION**  
 (CORNER PANEL ELEVATION SIMILAR)

---

**3 2 CORNER OR END PANEL WITH DEADMAN DETAIL**  
 NO SCALE

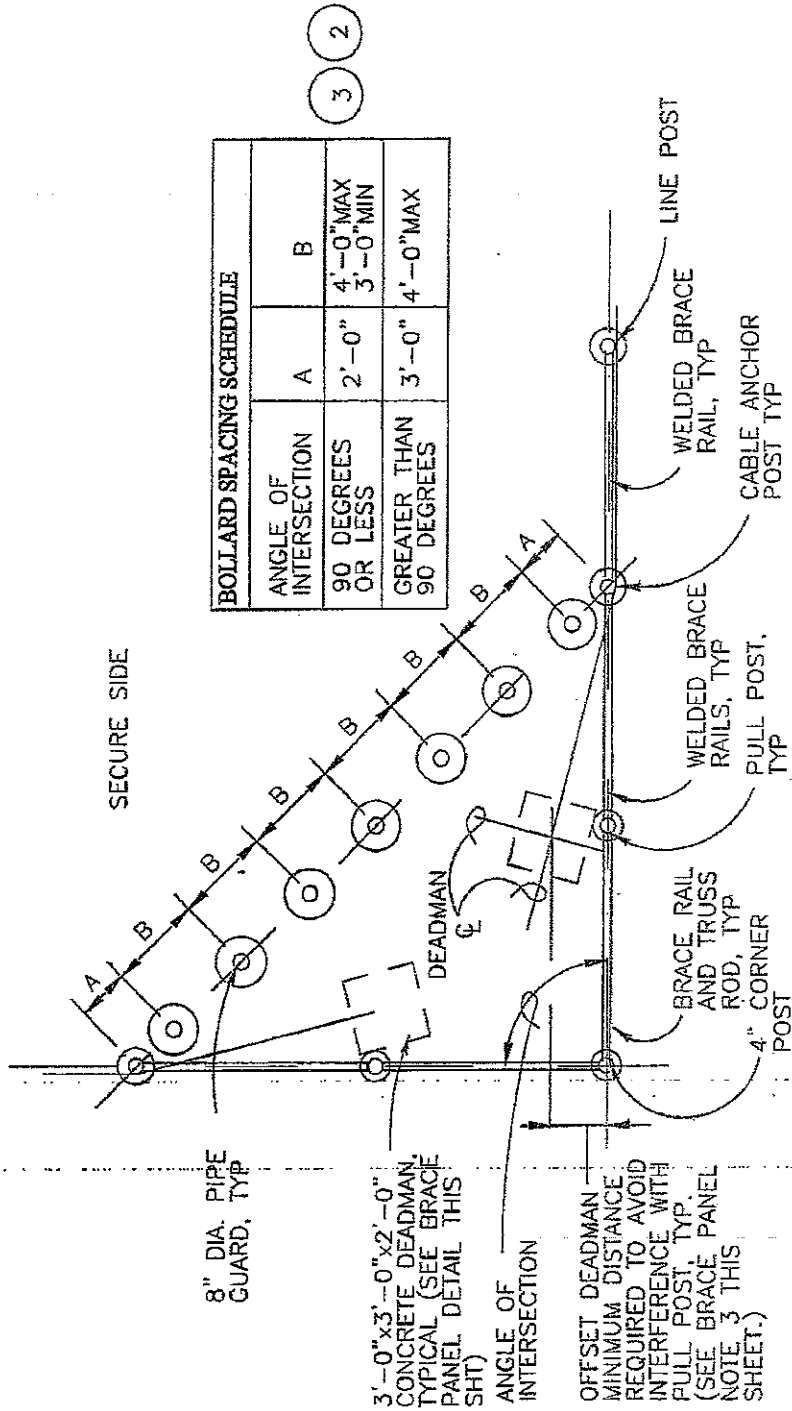

BOLLARD SPACING SCHEDULE		
ANGLE OF INTERSECTION	A	B
90 DEGREES OR LESS	2'-0"	4'-0" MAX 3'-0" MIN
GREATER THAN 90 DEGREES	3'-0"	4'-0" MAX

3

2

CORNER PLAN

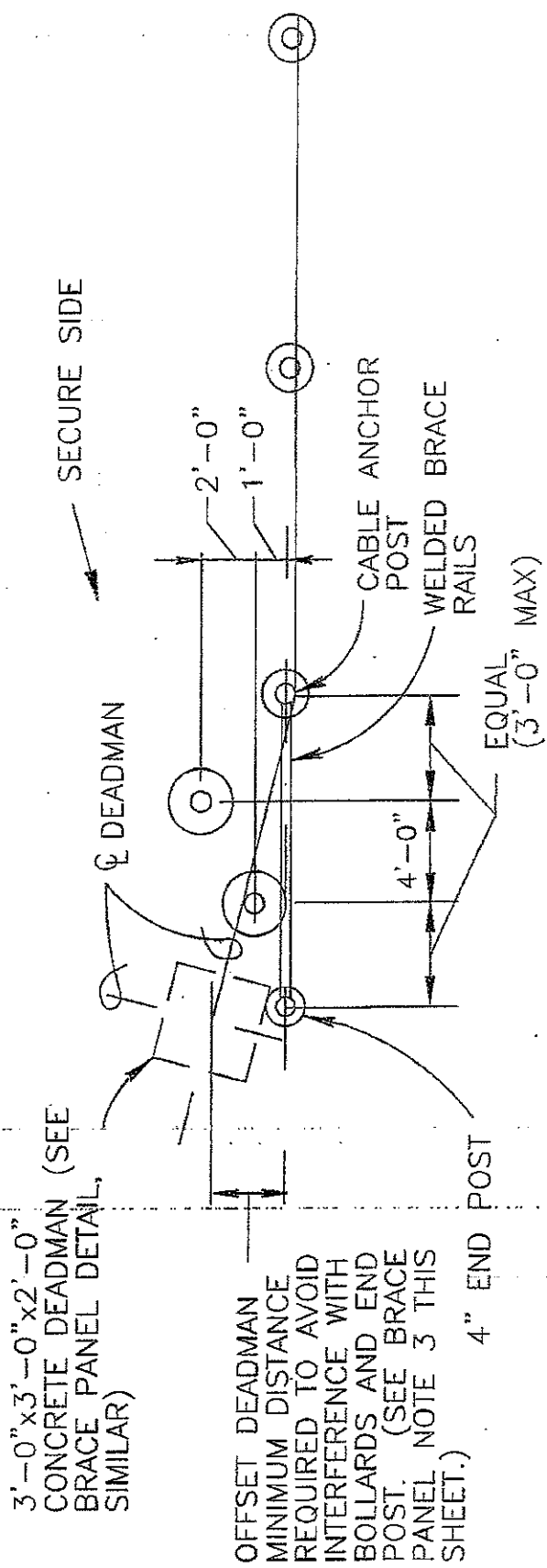

END PANEL PLAN



State of West Virginia  
 Department of Administration  
 Purchasing Division  
 2019 Washington Street East  
 Post Office Box 50130  
 Charleston, WV 25305-0130

# Request for Quotation

RFQ NUMBER  
**DEFK8220**

PAGE  
**1**

ADDRESS CORRESPONDENCE TO ATTENTION OF:  
**JOHN ABBOTT**  
**304-558-2544**

VENDOR

**RFQ COPY**  
**GLEM COMPANY**  
**PO BOX 2109**  
**CHARLESTON WV 25328**

SHIP TO

**DIV ENGINEERING & FACILITIES**  
**ARMORY BOARD SECTION**  
  
**1707 COONSKIN DRIVE**  
**CHARLESTON, WV**  
**25311-1099 341-6368**

DATE PRINTED	TERMS OF SALE	SHIP VIA	FOB	FREIGHT TERMS
05/05/2008				
BID OPENING DATE: 05/15/2008		BID OPENING TIME 01:30PM		

LINE	QUANTITY	UOP	CAT. NO.	ITEM NUMBER	UNIT PRICE	AMOUNT
<b>ADDENDUM #01</b>						
THIS ADDENDUM IS ISSUED TO MODIFY, ADD TO, AND DELETE THE REQUIREMENTS OF THE ORIGINAL REQUEST FOR QUOTATION SPECIFICATIONS, PER THE ATTACHED. INCLUDED IS BONDING FORMS FOR VENDOR'S USE.						
0001	1	LS		550-43	63,000. <sup>00</sup>	63,000. <sup>00</sup>
				TWO-STRAND CABLE VEHICULAR BARRIER		
***** THIS IS THE END OF RFQ DEFK8220 ***** TOTAL:						63,000. <sup>00</sup>

SEE REVERSE SIDE FOR TERMS AND CONDITIONS

SIGNATURE <i>Ken K. Hoffmann, C.S.</i>	TELEPHONE 304-342-2721	DATE 5/22/2008
TITLE CORPORATE SECRETARY	FEIN 55-017-9050	ADDRESS CHANGES TO BE NOTED ABOVE

WHEN RESPONDING TO RFQ, INSERT NAME AND ADDRESS IN SPACE ABOVE LABELED 'VENDOR'

**DEFK8220 - ADDENDUM #01**

- 1. DELETE: First Line Paragraph B, Page 10**
- 2. DELETE: First Line Paragraph D, Page 10**
- 3. DELETE Page 13 & 14, General Notes**
- 4. DELETE: Page 16, Brace Panel W/ Deadmen Detail**
- 5. DELETE: Page Page 17, Pipe Guard Detail,**
- 6. DELETE: Page 20, Deadman Detail**
- 7. DELETE: Page 21, Deadman Anchor**
- 8. DELETE: Page 24, End Panel Elevation**
- 9. DELETE: Page 25, Corner Plan**
- 10. DELETE: Page 26, End Panel Plan**
- 11. ADD: A-1, End of Run Detail, Elevation View**
- 12. ADD: A-2, End of Run Detail, Plan View**
- 13. ADD A-3, Corner Detail, Plan View.**
- 14. CHANGE: Page 15, Segment 1 & 2 are continuous**
- 15. CHANGE: Page 15, Corners will be installed between Segments 1&2, 5&8, 10&11, 17&18, And 19&20.**

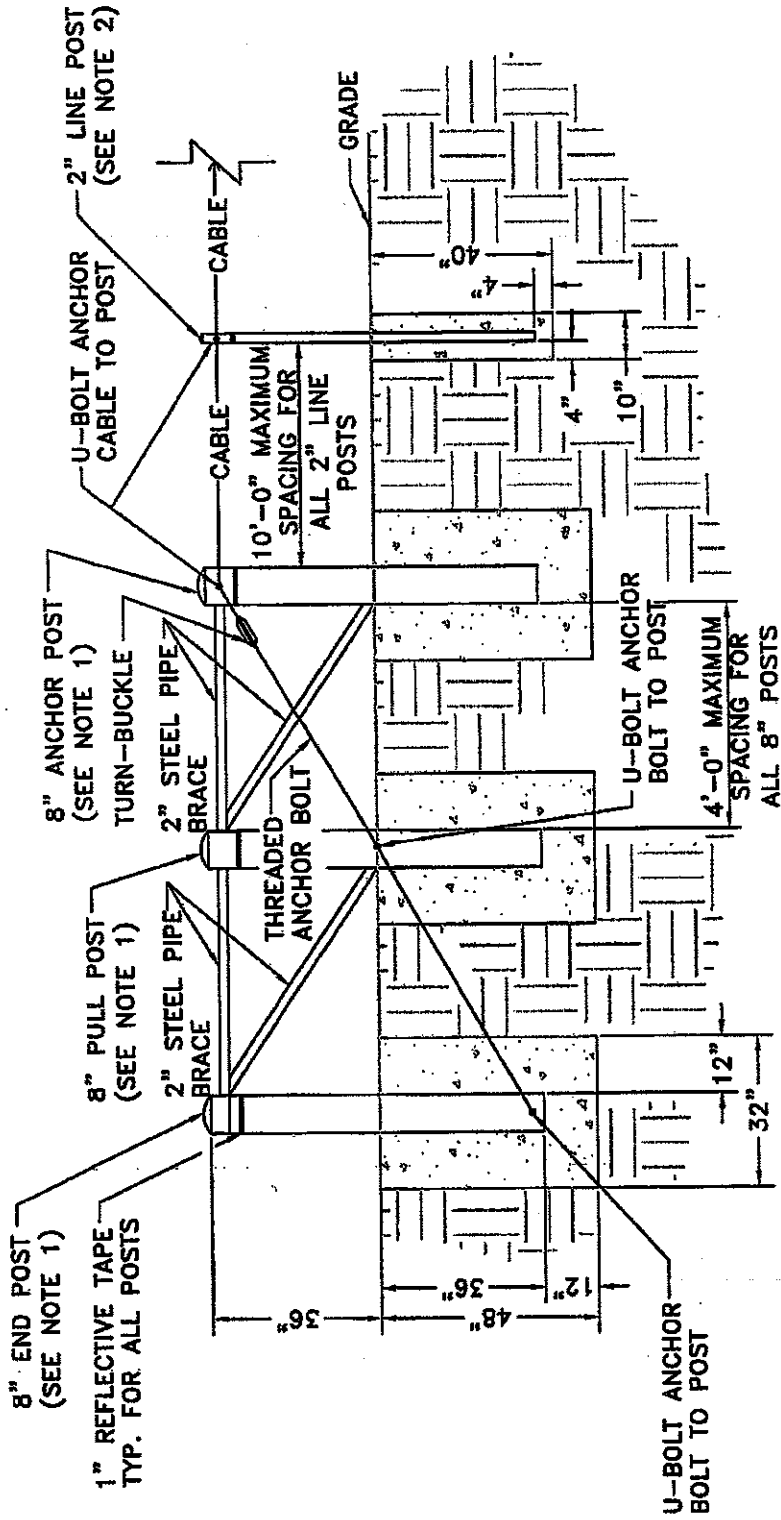

- NOTES:
1. 8"X 6' CONCRETE FILLED TO DOME; STEEL PIPE BOLLARD, WITH ONE WRAP OF 1" REFLECTIVE TAPE.
  2. 2"X 6' LINE POST AND CAP, WITH ONE WRAP OF 1" REFLECTIVE TAPE.

END OF RUN DETAIL  
ELEVATION VIEW

A-1

- NOTES:
1. 8"X 6' CONCRETE FILLED TO DOME, STEEL PIPE BOLLARD, WITH ONE WRAP OF 1" REFLECTIVE TAPE.
  2. 2"X 6' LINE POST AND CAP, WITH ONE WRAP OF 1" REFLECTIVE TAPE.

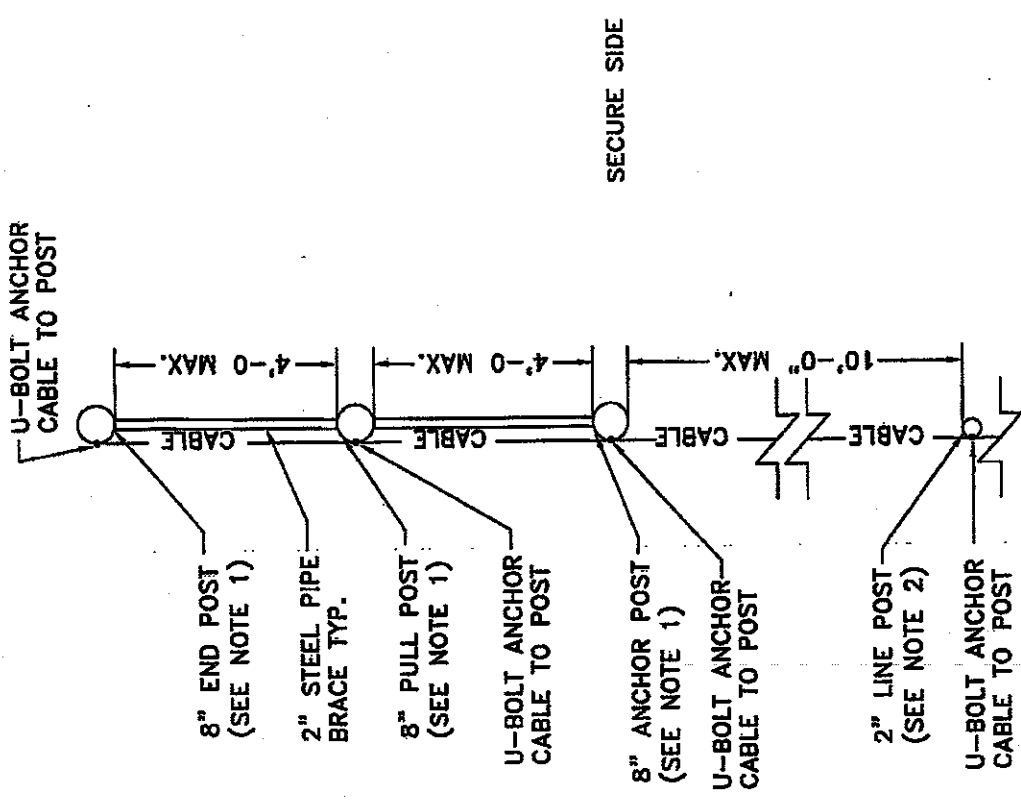

END OF RUN DETAIL  
PLAN VIEW

A-2

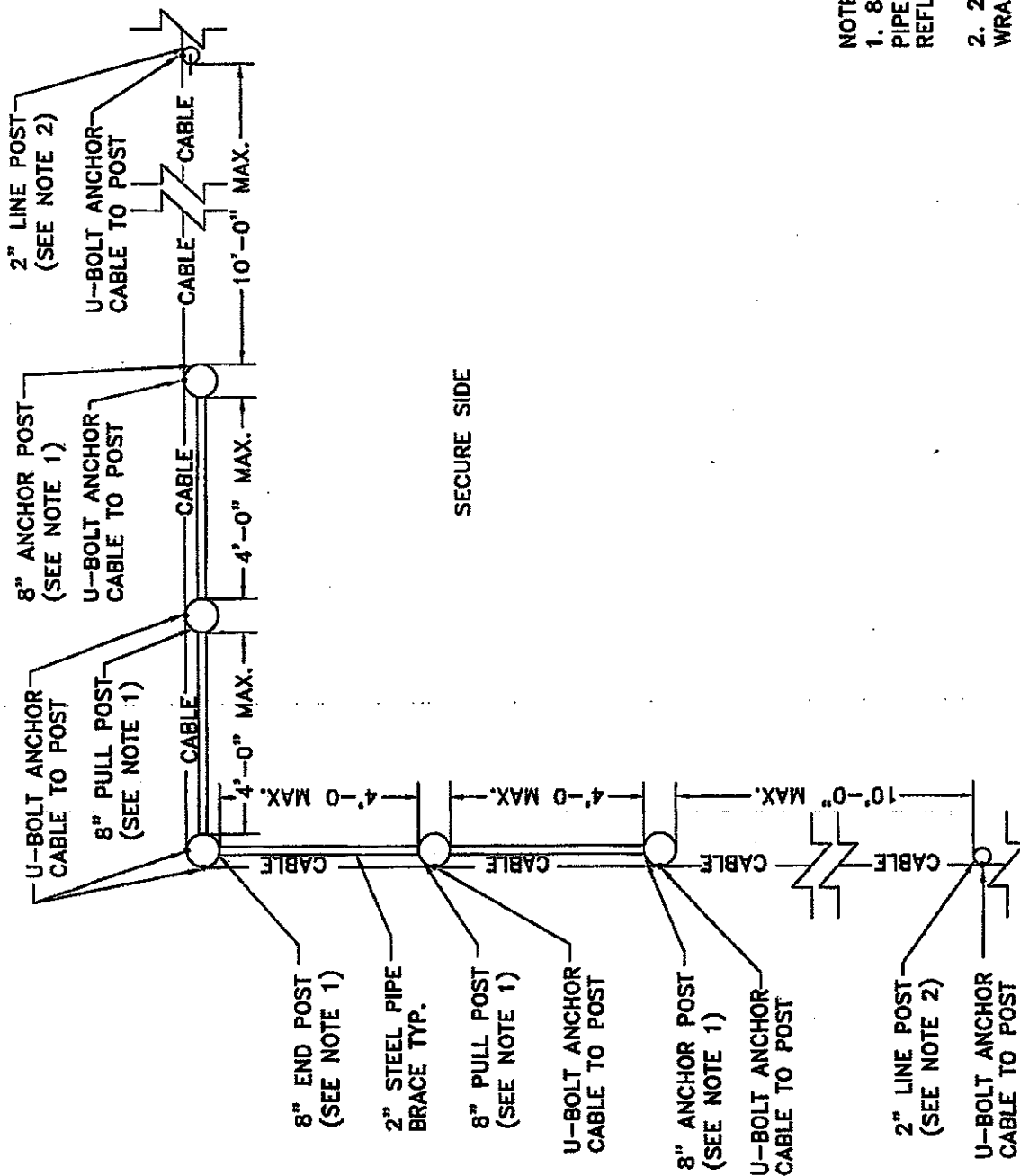

NOTES:

- 1. 8"x6' CONCRETE FILLED TO DOME, STEEL PIPE BOLLARD, WITH ONE WRAP OF 1" REFLECTIVE TAPE.
- 2. 2"x6' LINE POST AND CAP, WITH ONE WRAP OF 1" REFLECTIVE TAPE.
- 3. ELEVATION VIEW FOR CORNER SAME AS END OF RUN DETAIL, WITH A COMMON 8" END POST.

A-B



STATE OF WEST VIRGINIA  
Purchasing Division

## PURCHASING AFFIDAVIT

**West Virginia Code §5A-3-10a states:** No contract or renewal of any contract may be awarded by the state or any of its political subdivisions to any vendor or prospective vendor when the vendor or prospective vendor or a related party to the vendor or prospective vendor is a debtor and the debt owed is an amount greater than one thousand dollars in the aggregate

**DEFINITIONS:**

"Debt" means any assessment, premium, penalty, fine, tax or other amount of money owed to the state or any of its political subdivisions because of a judgment, fine, permit violation, license assessment, defaulted workers' compensation premium, penalty or other assessment presently delinquent or due and required to be paid to the state or any of its political subdivisions, including any interest or additional penalties accrued thereon.

"Debtor" means any individual, corporation, partnership, association, limited liability company or any other form or business association owing a debt to the state or any of its political subdivisions. "Political subdivision" means any county commission; municipality; county board of education; any instrumentality established by a county or municipality; any separate corporation or instrumentality established by one or more counties or municipalities, as permitted by law; or any public body charged by law with the performance of a government function or whose jurisdiction is coextensive with one or more counties or municipalities. "Related party" means a party, whether an individual, corporation, partnership, association, limited liability company or any other form or business association or other entity whatsoever, related to any vendor by blood, marriage, ownership or contract through which the party has a relationship of ownership or other interest with the vendor so that the party will actually or by effect receive or control a portion of the benefit, profit or other consideration from performance of a vendor contract with the party receiving an amount that meets or exceeds five percent of the total contract amount.

**EXCEPTION:** The prohibition of this section does not apply where a vendor has contested any tax administered pursuant to chapter eleven of this code, workers' compensation premium, permit fee or environmental fee or assessment and the matter has not become final or where the vendor has entered into a payment plan or agreement and the vendor is not in default of any of the provisions of such plan or agreement.

**LICENSING:** Vendors must be licensed and in good standing in accordance with any and all state and local laws and requirements by any state or local agency of West Virginia, including, but not limited to, the West Virginia Secretary of State's Office, the West Virginia Tax Department, West Virginia Insurance Commission, or any other state agencies or political subdivision. Furthermore, the vendor must provide all necessary releases to obtain information to enable the Director or spending unit to verify that the vendor is licensed and in good standing with the above entities.

**CONFIDENTIALITY:** The vendor agrees that he or she will not disclose to anyone, directly or indirectly, any such personally identifiable information or other confidential information gained from the agency, unless the individual who is the subject of the information consents to the disclosure in writing or the disclosure is made pursuant to the agency's policies, procedures and rules. Vendors should visit [www.state.wv.us/admin/purchase/privacy](http://www.state.wv.us/admin/purchase/privacy) for the Notice of Agency Confidentiality Policies.

Under penalty of law for false swearing (West Virginia Code, §61-5-3), it is hereby certified that the vendor acknowledges the information in this said affidavit and are in compliance with the requirements as stated.

Vendor's Name: GLEEM COMPANY

Authorized Signature: Ron K. Hoffman, C.I.S. Date: 5/22/2008

**BID BOND PREPARATION INSTRUCTIONS**

AGENCY \_\_\_\_\_ (A)  
 RFQ/RFP# \_\_\_\_\_ (B)

**Bid Bond**

- (A) WV State Agency  
(Stated on Page 1 "Spending Unit")  
Request for Quotation Number (upper  
right corner of page #1)
- (C) Your Company Name
- (D) City, Location of your Company
- (E) State, Location of your Company
- (F) Surety Corporate Name
- (G) City, Location of Surety
- (H) State, Location of Surety
- (I) State of Surety Incorporation
- (J) City of Surety Incorporation
- (K) Minimum amount of acceptable bid  
bond is 5% of total bid. You may state  
"5% of bid" or a specific amount on  
this line in words.
- (L) Amount of bond in figures
- (M) Brief Description of scope of work
- (N) Day of the month
- (O) Month
- (P) Year
- (Q) Name of Corporation
- (R) Raised Corporate Seal of Principal
- (S) Signature of President or Vice  
President
- (T) Title of person signing
- (U) Raised Corporate Seal of Surety
- (V) Corporate Name of Surety
- (W) Signature of Attorney in Fact of the  
Surety

KNOW ALL MEN BY THESE PRESENTS, That we, the undersigned,  
 \_\_\_\_\_ (C) of \_\_\_\_\_ (D) \_\_\_\_\_ (E)  
 as Principal, and \_\_\_\_\_ (F) of \_\_\_\_\_ (G),  
 \_\_\_\_\_ (H), a corporation organized and existing under the laws  
 of the State of \_\_\_\_\_ (I) with its principal office in the City of  
 \_\_\_\_\_ (J), as Surety, are held and firmly bound unto The State  
 of West Virginia, as Obligee, in the penal sum of \_\_\_\_\_ (K)  
 (\$ \_\_\_\_\_ (L)) for the payment of which, well and truly to be made,  
 we jointly and severally bind ourselves, our heirs, administrators, executors,  
 successors and assigns.

The Condition of the above obligation is such that whereas the Principal  
 has submitted to the Purchasing Section of the Department of Administration  
 a certain bid or proposal, attached hereto and made a part hereof to enter into a  
 contract in writing for \_\_\_\_\_ (M)

**NOW THEREFORE.**

(a) If said bid shall be rejected, or  
 (b) If said bid shall be accepted and the Principal shall enter into a  
 contract in accordance with the bid or proposal attached hereto and shall furnish  
 any other bonds and insurance required by the bid or proposal, and shall in all  
 other respects perform the agreement created by the acceptance of said bid then  
 this obligation shall be null and void, otherwise this obligation shall remain in full  
 force and effect. It is expressly understood and agreed that the liability of the  
 Surety for any and all claims hereunder shall, in no event, exceed the penal  
 amount of this obligation as herein stated

The Surety for value received, hereby stipulates and agrees that the  
 obligations of said Surety and its bond shall be in no way impaired or affected by  
 any extension of time within which the Obligee may accept such bid: and said  
 Surety does hereby waive notice of any such extension.

IN WITNESS WHEREOF, Principal and Surety have hereunto set their  
 hands and seals, and such of them as are corporations have caused their corporate  
 seals to be affixed hereto and these presents to be signed by their proper officers,  
 this \_\_\_\_\_ (N) day of \_\_\_\_\_ (O), 20 \_\_\_\_\_ (P).

Principal Corporate Seal

(R)

\_\_\_\_\_  
 (Name of Principal)  
 By \_\_\_\_\_  
 (Must be President or  
 Vice President)  
 \_\_\_\_\_  
 Title

(U)  
 Surety Corporate Seal

\_\_\_\_\_  
 (Name of Surety)

\_\_\_\_\_  
 Attorney-in-Fact

**IMPORTANT** – Surety executing bonds must be licensed in West Virginia to  
 transact surety insurance. Raised Corporate Seals must be affixed and a Power of  
 Attorney must be attached.

Agency \_\_\_\_\_  
REQ.P.O# \_\_\_\_\_

**BID BOND**

KNOW ALL MEN BY THESE PRESENTS, That we, the undersigned, \_\_\_\_\_  
of \_\_\_\_\_, \_\_\_\_\_, as Principal, and \_\_\_\_\_  
of \_\_\_\_\_, \_\_\_\_\_, a corporation organized and existing under the laws of the State of \_\_\_\_\_  
with its principal office in the City of \_\_\_\_\_, as Surety, are held and firmly bound unto the State  
of West Virginia, as Obligee, in the penal sum of \_\_\_\_\_ (\$ \_\_\_\_\_) for the payment of which,  
well and truly to be made, we jointly and severally bind ourselves, our heirs, administrators, executors, successors and assigns.

The Condition of the above obligation is such that whereas the Principal has submitted to the Purchasing Section of the  
Department of Administration a certain bid or proposal, attached hereto and made a part hereof, to enter into a contract in writing for  
\_\_\_\_\_  
\_\_\_\_\_  
\_\_\_\_\_

**NOW THEREFORE,**

(a) If said bid shall be rejected, or  
(b) If said bid shall be accepted and the Principal shall enter into a contract in accordance with the bid or proposal attached  
hereto and shall furnish any other bonds and insurance required by the bid or proposal, and shall in all other respects perform the  
agreement created by the acceptance of said bid, then this obligation shall be null and void, otherwise this obligation shall remain in full  
force and effect. It is expressly understood and agreed that the liability of the Surety for any and all claims hereunder shall, in no event,  
exceed the penal amount of this obligation as herein stated.

The Surety, for the value received, hereby stipulates and agrees that the obligations of said Surety and its bond shall be in no  
way impaired or affected by any extension of the time within which the Obligee may accept such bid, and said Surety does hereby  
waive notice of any such extension.

IN WITNESS WHEREOF, Principal and Surety have hereunto set their hands and seals, and such of them as are corporations  
have caused their corporate seals to be affixed hereunto and these presents to be signed by their proper officers, this  
\_\_\_\_\_ day of \_\_\_\_\_, 20\_\_\_\_\_.

Principal Corporate Seal

\_\_\_\_\_  
(Name of Principal)

By \_\_\_\_\_  
(Must be President or  
Vice President)

\_\_\_\_\_  
(Title)

Surety Corporate Seal

\_\_\_\_\_  
(Name of Surety)

\_\_\_\_\_  
Attorney-in-Fact

**IMPORTANT – Surety executing bonds must be licensed in West Virginia to transact surety insurance. Raised corporate seals  
must be affixed, a power of attorney must be attached.**

**LABOR AND MATERIAL PAYMENT BOND**

KNOW ALL MEN BY THESE PRESENTS:

That \_\_\_\_\_  
(Name, address or legal title of the Contractor)

as Principal, hereinafter called Contractor, and \_\_\_\_\_  
\_\_\_\_\_ a corporation organized and existing under  
the laws of the State of \_\_\_\_\_, with its principal office in the City of \_\_\_\_\_

as Surety, hereinafter called Surety, are held firmly bound unto \_\_\_\_\_  
(Name, address or legal title of Owner)

as Obligee, hereinafter called Owner, for the use and benefit of claimants as herein below defined in the amount of  
\_\_\_\_\_ Dollars (\$ \_\_\_\_\_),  
for the payment whereof Principal and Surety bind themselves, their heirs, executors, administrators, successors and  
assigns, jointly and severally, firmly by these presents.

WHEREAS, Contractor has by written agreement dated \_\_\_\_\_  
\_\_\_\_\_ entered into a contract with Owner for  
\_\_\_\_\_

in accordance with drawings and specifications prepared by \_\_\_\_\_  
\_\_\_\_\_

which contract is by reference made a part hereof, and is hereinafter referred to as the CONTRACT

NOW, THEREFORE, THE CONDITION OF THIS OBLIGATION is such that if Contractor shall, well and truly perform the contract, and shall pay off, satisfy and discharge all claims of subcontractors, labors, materialmen and all persons furnishing material or doing work pursuant to the CONTRACT and shall save Owner and its property harmless from any and all liability over and above the contract price thereof, between the owner and the Contractor, for all of such labor and material, and shall fully pay off and discharge and secure the release of any and all mechanics liens which may be placed upon said property by any such subcontractor, laborer or materialmen, then this obligation shall be null and void. Otherwise, it shall remain in full force and effect.

Signed and sealed this \* \_\_\_\_\_ day of \_\_\_\_\_

Principal Raised Corporate Seal \_\_\_\_\_ (Seal)  
(Contractor Name)

Surety Raised Corporate Seal \_\_\_\_\_ (Seal)  
(Must be President or Vice President)

\_\_\_\_\_  
(Title)

\_\_\_\_\_  
(Surety)

By \_\_\_\_\_ (Seal)

NOTE: Raised Corporate Seals are mandatory.  
Please attach Power of Attorney

NOTE: Applicable Section of attached acknowledge-  
ment must be completed and returned as part of  
the bond.

\* Power of Attorney must be certified on this date or later.

**ACKNOWLEDGEMENTS**

**Acknowledgement by Principal if individual or Partnership**

- 1. STATE OF \_\_\_\_\_
- 2. County of \_\_\_\_\_ to-wit:
- 3. I, \_\_\_\_\_, a Notary Public in and for the
- 4. county and state aforesaid, do hereby certify that \_\_\_\_\_ whose name is signed to the foregoing writing, has this day acknowledged the same before me in my said county.
- 5. Given under my hand this \_\_\_\_\_ day of \_\_\_\_\_ 20\_\_\_\_\_.
- 6. Notary Seal
- 7. \_\_\_\_\_ (Notary Public)
- 8. My commission expires on the \_\_\_\_\_ day of \_\_\_\_\_ 20\_\_\_\_\_.

**Acknowledgement by Principal if Corporation**

- 9. STATE OF \_\_\_\_\_
- 10. County of \_\_\_\_\_ to-wit:
- 11. I, \_\_\_\_\_, a Notary Public in and for the
- 12. county and state aforesaid, do hereby certify that \_\_\_\_\_
- 13. who as, \_\_\_\_\_ signed the foregoing writing for
- 14. \_\_\_\_\_ a corporation, has this day, in my said county, before me, acknowledged the said writing to be the act and deed of the said corporation.
- 15. Given under my hand this \_\_\_\_\_ day of \_\_\_\_\_ 20\_\_\_\_\_.
- 16. Notary Seal
- 17. \_\_\_\_\_ (Notary Public)
- 18. My commission expires on the \_\_\_\_\_ day of \_\_\_\_\_ 20\_\_\_\_\_.

**Acknowledgement by Surety**

- 19. STATE OF \_\_\_\_\_
- 20. County of \_\_\_\_\_ to-wit:
- 21. I, \_\_\_\_\_, a Notary Public in and for the
- 22. county and state aforesaid, do hereby certify that \_\_\_\_\_
- 23. who as, \_\_\_\_\_ signed the foregoing writing for
- 24. \_\_\_\_\_ a corporation, has this day, in my said county, before me, acknowledged the said writing to be the act and deed of the said corporation.
- 25. Given under my hand this \_\_\_\_\_ day of \_\_\_\_\_ 20\_\_\_\_\_.
- 26. Notary Seal
- 27. \_\_\_\_\_ (Notary Public)
- 28. My commission expires on the \_\_\_\_\_ day of \_\_\_\_\_ 20\_\_\_\_\_.

**Sufficiency in Form and Manner  
Of Execution Approved**

**Attorney General**

This \_\_\_\_\_ day of \_\_\_\_\_ 20 \_\_\_\_\_

By \_\_\_\_\_  
(Assistant Attorney General)

PERFORMANCE BOND

KNOW ALL MEN BY THESE PRESENTS:

That \_\_\_\_\_ (Name, address or legal title of the Contractor)

as Principal, hereinafter called Contractor, and \_\_\_\_\_ a corporation organized and existing under the laws of the State of \_\_\_\_\_, with its principal office in the City of \_\_\_\_\_

as Surety, hereinafter called Surety, are held firmly bound unto \_\_\_\_\_ (Name, address or legal title of Owner)

as Obligee, hereinafter called Owner, in the amount of \_\_\_\_\_

Dollars (\$ \_\_\_\_\_ ), for the payment whereof Contractor and Surety bind themselves, their heirs, executors, administrators, successors, and assigns, jointly and severally, firmly by these presents.

WHEREAS, Contractor has by written agreement dated \_\_\_\_\_ entered into a contract with Owner for \_\_\_\_\_

in accordance with drawings and specifications prepared by \_\_\_\_\_

which contract is by reference made a part hereof, and is hereinafter referred to as the CONTRACT

NOW, THEREFORE, THE CONDITION OF THIS OBLIGATION is such that if Contractor shall, promptly and faithfully Perform and CONTRACT, then this obligation shall be null and void, otherwise it shall remain in full force and effect.

The Surety hereby waives notice of any alteration or extension of time made by the Owner.

Whenever Contractor shall be, and declared by Owner to be in default under the CONTRACT, the Owner having performed Owner's obligations thereunder, the Surety may promptly remedy the default, or shall promptly:

- 1. Complete the CONTRACT in accordance with its terms and conditions, and
2. Shall save the Owner harmless from any claims, judgments, or liens arising from the Surety's failure to either remedy the default or to complete the CONTRACT in accordance with its terms and conditions in a timely manner.

No right of action shall accrue on this bond to or for the use of any person or corporation other than the Owner named herein or the successors of Owner.

Signed and sealed this \* \_\_\_\_\_ day of \_\_\_\_\_

Principal Raised Corporate Seal \_\_\_\_\_ (Seal) (Contractor Name)

Surety Raised Corporate Seal By \_\_\_\_\_ (Seal) (Must be President or Vice President)

\_\_\_\_\_  
(Title)

\_\_\_\_\_  
(Surety)

By \_\_\_\_\_ (Seal)

NOTE: Raised Corporate Seals are mandatory. Please attach Power of Attorney

NOTE: Applicable Section of attached acknowledgment must be completed and returned as part of the bond.

\* Power of Attorney must be certified on this date or later.

**Acknowledgement by Principal if individual or Partnership**

- 1. STATE OF \_\_\_\_\_
- 2. County of \_\_\_\_\_ to-wit:
- 3. I, \_\_\_\_\_, a Notary Public in and for the
- 4. county and state aforesaid, do hereby certify that \_\_\_\_\_  
whose name is signed to the foregoing writing, has this day acknowledged the same before me in my said county.
- 5. Given under my hand this \_\_\_\_\_ day of \_\_\_\_\_ 20 \_\_\_\_\_.
- 6. Notary Seal
- 7. \_\_\_\_\_  
(Notary Public)
- 8. My commission expires on the \_\_\_\_\_ day of \_\_\_\_\_ 20 \_\_\_\_\_.

**Acknowledgement by Principal if Corporation**

- 9. STATE OF \_\_\_\_\_
- 10. County of \_\_\_\_\_ to-wit:
- 11. I, \_\_\_\_\_, a Notary Public in and for the
- 12. county and state aforesaid, do hereby certify that \_\_\_\_\_
- 13. who as, \_\_\_\_\_ signed the foregoing writing for
- 14. \_\_\_\_\_ a corporation,  
has this day, in my said county, before me, acknowledged the said writing to be the act and deed of the said corporation.
- 15. Given under my hand this \_\_\_\_\_ day of \_\_\_\_\_ 20 \_\_\_\_\_.
- 16. Notary Seal
- 17. \_\_\_\_\_  
(Notary Public)
- 18. My commission expires on the \_\_\_\_\_ day of \_\_\_\_\_ 20 \_\_\_\_\_.

**Acknowledgement by Surety**

- 19. STATE OF \_\_\_\_\_
- 20. County of \_\_\_\_\_ to-wit:
- 21. I, \_\_\_\_\_, a Notary Public in and for the
- 22. county and state aforesaid, do hereby certify that \_\_\_\_\_
- 23. who as, \_\_\_\_\_ signed the foregoing writing for
- 24. \_\_\_\_\_ a corporation,  
has this day, in my said county, before me, acknowledged the said writing to be the act and deed of the said corporation.
- 25. Given under my hand this \_\_\_\_\_ day of \_\_\_\_\_ 20 \_\_\_\_\_.
- 26. Notary Seal
- 27. \_\_\_\_\_  
(Notary Public)
- 28. My commission expires on the \_\_\_\_\_ day of \_\_\_\_\_ 20 \_\_\_\_\_.

**Sufficiency in Form and Manner  
Of Execution Approved**

**Attorney General**

This \_\_\_\_\_ day of \_\_\_\_\_ 20 \_\_\_\_\_

By \_\_\_\_\_  
(Assistant Attorney General)

---

## ACKNOWLEDGEMENT PREPARATION INSTRUCTIONS

---

1. IF PRINCIPAL IS AN INDIVIDUAL OR PARTNERSHIP, HAVE NOTARY COMPLETE LINES (1) through (8).
2. IF PRINCIPAL IS A CORPORATION, HAVE NOTARY COMPLETE LINES (9) through (18).
3. SURETY MUST HAVE NOTARY COMPLETE LINES (19) through (28).
4. **Notaries must:**

---

### ACKNOWLEDGEMENT BY PRINCIPAL IF INDIVIDUAL OR PARTNERSHIP

---

1. Enter name of State.
2. Enter name of County.
3. Enter name of Notary Public witnessing transactions.
4. Enter name of principal covered by bond if individual or partnership. Notary enters date bond was witnessed.
5. Must be the same as or later than signature date.
6. Affix Notary Seal.
7. Notary affixes his/her signature.
8. Notary enters commission date.

---

### ACKNOWLEDGEMENT BY PRINCIPAL IF CORPORATION

---

9. Enter name of State.
10. Enter name of County.
11. Enter name of Notary Public witnessing transactions.
12. Enter name of Corporate Officer signing bond. (Must be President or Vice President.)
13. Enter Title of Corporate Officer signing bond.
14. Enter name of Company or Corporation.
15. Notary enters date bond was witnessed. Must be the same as or later than signature date.
16. Affix Notary Seal.
17. Notary affixes his/her signature.
18. Notary enters commission date.

---

### ACKNOWLEDGEMENT BY SURETY

---

19. Enter name of State.
20. Enter name of County.
21. Enter name of Notary Public witnessing transactions.
22. Enter name of person having power of attorney to bind Surety Company.
23. Enter Title of person binding Surety Company.
24. Enter name of Insurance Company (Surety).
25. Notary enters date bond was witnessed. Must be the same as or later than signature date.
26. Affix Notary Seal.
27. Notary affixes his/her signature.
28. Notary enters commission date.

---

### POWER OF ATTORNEY INSTRUCTIONS

---

Power of attorney for surety must be attached showing that it was in full force and effect on signature date indicated on the face of the bond. A raised corporate seal must also be affixed to the Power of Attorney form.

- a. Name of attorney in fact must be listed (if attorney is a non-resident, bond must be countersigned by West Virginia resident agent).
- b. Power of Attorney may not exceed imposed limitations.
- c. Certificate date, the signature date of bond must be entered.
- d. Signature of authorizing official must be affixed. (Signature may be facsimile).
- e. **Raised seal must be affixed.**







State of West Virginia  
 Department of Administration  
 Purchasing Division  
 2019 Washington Street East  
 Post Office Box 50130  
 Charleston, WV 25305-0130

# Request for Quotation

RFQ NUMBER  
 DEFK8220

PAGE  
 1

ADDRESS CORRESPONDENCE TO ATTENTION OF  
 JOHN ABBOTT  
 304-558-2544

\*926135203 304-342-2721

VENDOR

GLEM COMPANY  
 PO BOX 2109

CHARLESTON WV 25328

SHIP TO

DIV ENGINEERING & FACILITIES  
 ARMORY BOARD SECTION

1707 COONSKIN DRIVE  
 CHARLESTON, WV  
 25311-1099 341-6368

DATE PRINTED	TERMS OF SALE	SHIP VIA	F.O.B.	FREIGHT TERMS
05/14/2008				
BID OPENING DATE: 05/22/2008		BID OPENING TIME 01:30PM		

LINE	QUANTITY	UOP	CAT. NO.	ITEM NUMBER	UNIT PRICE	AMOUNT
				ADDENDUM #02		
				THIS ADDENDUM IS ISSUED TO EXTEND THE BID OPENING DATE FROM 5/15/2008, TO 5/22/2008; 1:30 PM; AND TO ANSWER VENDOR QUESTIONS, PER THE ATTACHED.		
0001	1	LS		550-43	63,000. <sup>00</sup>	63,000. <sup>00</sup>
				TWO-STRAND CABLE VEHICULAR BARRIER		

SEE REVERSE SIDE FOR TERMS AND CONDITIONS

SIGNATURE <i>Ken K. Hoffmann, Corporate Secretary</i>	TELEPHONE 1-304-342-2721	DATE 5/22/2008
TITLE CORPORATE SECRETARY	FEIN 55-0179050	ADDRESS CHANGES TO BE NOTED ABOVE

WHEN RESPONDING TO RFQ, INSERT NAME AND ADDRESS IN SPACE ABOVE LABELED 'VENDOR'

**DEFK8220 – Addendum #02****Firm Questions With Agency's Response****QUESTIONS:**

- (1) Is this going to be a two cable barrier ?**
- (2) Do we attach turn buckles to cable by means of (4) clamps and thimble ?**
- (3) Is there an area on site for spoils?**
- (4) Is all piping to be galvanized?**
- (5) Does the entire cable bearer get chain link fabric and if so, how does it attach?**

**ANSWERS:**

**Question 1: Yes; two-cable**

**Question 2: Yes; thimble end**

**Question 3: No; spoil will be removed**

**Question 4: Yes; all to be galvanized**

**Question 5: No; no fence fabric**

THIS CHECK IS PRINTED ON CHEMICAL REACTIVE PAPER WHICH CONTAINS A WATERMARK. VERIFY FOR AUTHENTICITY.

**City**  
NATIONAL BANK

NOTICE TO CUSTOMERS: THE PURCHASE OF AN INDEMNITY BOND  
WILL BE REQUIRED BEFORE ANY OFFICIAL CHECK OF THIS BANK  
WILL BE REPLACED OR REFUNDED IN THE EVENT IT IS LOST, MISPLACED  
OR STOLEN. ANY QUESTIONS PLEASE CALL (304) 769-1320.

**CASHIERS CHECK**  
10021656

Date: 5/22/08

Branch: 0010

REMITTER GLEM COMPANY

**PAY** EXACTLY \*\*3,150 AND 00/100 DOLLARS  
**TO THE**  
**ORDER OF** STATE OF WEST VIRGINIA

\$3,150.00

RFO # DEFK8220

*Jerry W. Childers*

