



State of West Virginia
 Department of Administration
 Purchasing Division
 2019 Washington Street East
 Post Office Box 50130
 Charleston, WV 25305-0130

**Request for
 Quotation**

RFQ NUMBER:
DEFK8052

PAGE:
1

ADDRESS CORRESPONDENCE TO ATTENTION OF:
**JOHN ABBOTT
 304-558-2544**

RFQ COPY
 TYPE NAME/ADDRESS HERE

**DIV ENGINEERING & FACILITIES
 ARMORY BOARD SECTION
 1707 COONSKIN DRIVE
 CHARLESTON, WV
 25311-1099 341-6368**

| DATE PRINTED | TERMS OF SALE | SHIP VIA | FOB | FREIGHT TERMS |
|--------------|---------------|----------|-----|---------------|
| 09/17/2007 | | | | |

BID OPENING DATE: **09/26/2007** BID OPENING TIME: **01:30PM**

| LINE | QUANTITY | UOP | CAT. NO. | ITEM NUMBER | UNIT PRICE | AMOUNT |
|---|----------|-----|----------|-------------|------------|---------------------------------|
| ADDENDUM #01 | | | | | | |
| THIS ADDENDUM IS ISSUED TO MODIFY, CLARIFY, ADD TO, AND/OR DELETE THE REQUIREMENTS OF THE ORIGINAL SPECIFICATIONS, AND TO EXTEND THE BID OPENING DATE FROM 9/20/2007 TO 9/26/2007; 1:30 PM. | | | | | | |
| ATTACHMENTS: ADDENDUM #01 & PRE-BID SIGN-IN SHEET | | | | | | |
| NEW BID OPENING DATE: 9/26/2007; 1:30 PM | | | | | | |
| 0001 | 1 | LS | | 550-43 | | |
| SAFETY BARRIERS, TRAFFIC (STATIONARY) | | | | | | |
| ***** THIS IS THE END OF RFQ DEFK8052 ***** TOTAL: | | | | | | <u>\$ 292,360.⁰⁰</u> |

SEE REVERSE SIDE FOR TERMS AND CONDITIONS

SIGNATURE: *[Signature]* TELEPHONE: **304-865-9292** DATE: **9/25/07**
 TITLE: **Owner** PERM: **55-064-0887** ADDRESS CHANGES TO BE NOTED ABOVE

WHEN RESPONDING TO RFQ, INSERT NAME AND ADDRESS IN SPACE ABOVE LABELED 'VENDOR'

**GENERAL TERMS & CONDITIONS
REQUEST FOR QUOTATION (RFQ) AND REQUEST FOR PROPOSAL (RFP)**

1. Awards will be made in the best interest of the State of West Virginia.
2. The State may accept or reject in part, or in whole, any bid.
3. All quotations are governed by the *West Virginia Code* and the *Legislative Rules* of the Purchasing Division.
4. Prior to any award, the apparent successful vendor must be properly registered with the Purchasing Division and have paid the required \$125.00 registration fee.
5. All services performed or goods delivered under State Purchase Orders/Contracts are to be continued for the term of the Purchase Order/Contract, contingent upon funds being appropriated by the Legislature or otherwise being made available. In the event funds are not appropriated or otherwise available for these services or goods, this Purchase Order/Contract becomes void and of no effect after June 30.
6. Payment may only be made after the delivery and acceptance of goods or services.
7. Interest may be paid for late payment in accordance with the *West Virginia Code*.
8. Vendor preference will be granted upon written request in accordance with the *West Virginia Code*.
9. The State of West Virginia is exempt from federal and state taxes and will not pay or reimburse such taxes.
10. The Director of Purchasing may cancel any Purchase Order/Contract upon 30 days written notice to the seller.
11. The laws of the State of West Virginia and the *Legislative Rules* of the Purchasing Division shall govern all rights and duties under the Contract, including without limitation the validity of this Purchase Order/Contract.
12. Any reference to automatic renewal is hereby deleted. The Contract may be renewed only upon mutual written agreement of the parties.
13. **BANKRUPTCY:** In the event the vendor/contractor files for bankruptcy protection, this contract is automatically null and void, and is terminated without further order.
14. **HIPAA Business Associate Addendum** - The West Virginia State Government HIPAA Business Associate Addendum (BAA), approved by the Attorney General, and available online at the Purchasing Division's web site (<http://www.state.wv.us/admin/purchase/vrc/hipaa.htm>) is hereby made part of the agreement. Provided that, the Agency meets the definition of a Covered Entity (45 CFR §160.103) and will be disclosing Protected Health Information (45 CFR §160.103) to the vendor.

INSTRUCTIONS TO BIDDERS

1. Use the quotation forms provided by the Purchasing Division.
2. **SPECIFICATIONS:** Items offered must be in compliance with the specifications. Any deviation from the specifications must be clearly indicated by the bidder. Alternates offered by the bidder as **EQUAL** to the specifications must be clearly defined. A bidder offering an alternate should attach complete specifications and literature to the bid. The Purchasing Division may waive minor deviations to specifications.
3. Complete all sections of the quotation form.
4. Unit prices shall prevail in cases of discrepancy.
5. All quotations are considered F.O.B. destination unless alternate shipping terms are clearly identified in the quotation.
6. **BID SUBMISSION:** All quotations must be delivered by the bidder to the office listed below prior to the date and time of the bid opening. Failure of the bidder to deliver the quotations on time will result in bid disqualifications.

SIGNED BID TO:

Department of Administration
Purchasing Division
2019 Washington Street East
Post Office Box 50130
Charleston, WV 25305-0130

DEFK 8052

ADDENDUM:

1. Change / Clarify Line 0001, Paragraph 8.0: Period of Service is 6 months from Notice to Proceed.
2. ADD to Paragraph 4.1.2: The contractor will place 6" of #57 gravel over filter fabric behind wall prior to backfilling in order to allow drainage through weep holes.
3. Change / Clarify Line 0001, Paragraph 10.0: The Bid will be submitted as:

| Item | Description | Estimated Quantities | Unit Price | Total Cost |
|-----------|-----------------------------------|----------------------|--------------------|------------------------|
| Base Item | Installed Concrete Barrier | 2,000' | 146. ¹⁸ | 292,360. ⁰⁰ |
| ADD / QTY | Additional Wall Section Installed | 1 LF | 146. ¹⁸ | 146. ¹⁸ |
| ADD / QTY | Additional Post Installed | 1 EA | 540. ⁰⁰ | 540. ⁰⁰ |



**WEST VIRGINIA ARMY NATIONAL GUARD
CONSTRUCTION & FACILITIES MANAGEMENT OFFICE**
1703 Coonskin Drive
Charleston, West Virginia 25311-1085
Phone: 304-561-6539 Fax: 304-561-6458 DSN: 623-6331



SUBJECT: Agenda, Pre-Bid, Coonskin Barriers (DEFK8052)

1. Administrative:

- A. Sign-In Sheet
- C. Funding: Federally funded
- D. User: West Virginia Army National Guard

2. Introduction:

- A. C&FMO Representative: Major Harold Butler (304) 561-6539.
- B. State Purchasing Senior Buyer: John Abbott (304) 558-2544
- C. There is non A&E for this project.
- D. Environmental Program Management Officer: COL Gary Blackhurst, (304) 561-6445

3. General:

A. Questions must be submitted to Mr. Abbott.

B. Work Hours/ Access to the Site/Temporary Facilities

- 1. Normal work-hours are from 7: a.m. 4:00 p.m. Monday to Friday.
- 2. Contractor must submit a schedule of work to include a request to extend work hours if needed to the Project Manager.
- 3. Contractor is required to provide to the Project Manager, a listing of personnel, which will be gaining access to the site.

C. Temporary Facilities:

1. Job trailer, equipment and material storage may be located on site with approval from the WVARNG (Limited Space).

2. Contractor must provide all facilities for contractor use.

D. Safety

1. All construction activities will be in conjunction with OSHA, Safety and Health Requirements Manual. All construction activities on site will be a hardhat area and marked as such.

2. Access to the site will be restricted and controlled by the Contractor. A visitor's sign-in and hardhats are to be made available for personnel visiting site.

3. Cleanup is required daily. No open dumps of construction materials. Remove surplus soil material, unsuitable topsoil, obstructions, demolished materials, and waste materials including trash and debris, and legally dispose of them off Owner's property.

4. Contractor is responsible for keeping driveways and entrances serving the premises clear and available for the Owner's use.

E. Supervision of Work:

1. Work must be supervised and the WVARNG must be informed of the responsible person on site.

2. Substitution requests must be submitted within 60 days of commencement of work.

4. Summary of Work:

A. Project Description:

- 1. Review Scope of Work
- 2. View Site

5. Environmental Comments:



State of West Virginia
 Department of Administration
 Purchasing Division
 2019 Washington Street East
 Post Office Box 50130
 Charleston, WV 25305-0130

Request for Quotation

RFO NUMBER
DEFK8052

PAGE
1

ADDRESS CORRESPONDENCE TO ATTENTION OF
JOHN ABBOTT
304-558-2544

VENDOR

T.L. Smith Excavating
357 Old St. Mary's Pike
Parkersburg, WV 26104

SHIP TO

DIV ENGINEERING & FACILITIES
ARMORY BOARD SECTION

1707 COONSKIN DRIVE
CHARLESTON, WV
25311-1099 341-6368

| | | | | |
|-----------------------------------|---------------|----------|--------|---------------|
| DATE PRINTED 08/22/2007 | TERMS OF SALE | SHIP VIA | F.O.B. | FREIGHT TERMS |
|-----------------------------------|---------------|----------|--------|---------------|

BID OPENING DATE: **09/20/2007** BID OPENING TIME **01:30PM**

| LINE | QUANTITY | UOP | CAT NO | ITEM NUMBER | UNIT PRICE | AMOUNT |
|------|----------|-----|--------|--|------------|--------|
| | | | | REQUEST FOR QUOTATION | | |
| | | | | THE PURCHASING DIVISION IS SOLICITING BIDS FOR THE WEST VIRGINIA ARMY NATIONAL GUARD TO PROVIDE ALL LABOR, EQUIPMENT, AND MATERIALS NECESSARY TO INSTALL CONCRETE BARRIER WALLS. | | |
| | | | | ATTACHMENTS: 1. SPECIFICATIONS 2. BID FORM 3. PURCHASING AFFIDAVIT | | |
| | | | | MANDATORY ON-SITE PRE-BID: 9/14/2007; 10:00 AM WV ARMY NATIONAL GUARD 1703 COONSKIN DRIVE CHARLESTON, WV 25311 | | |
| 0001 | 1 | LS | | 550-43 | | |
| | | | | SAFETY BARRIERS, TRAFFIC (STATIONARY) | | |
| | | | | EXHIBIT 5 | | |
| | | | | NOTICE TO PROCEED: THIS CONTRACT IS TO BE PERFORMED WITHIN 90 CALENDAR DAYS AFTER THE NOTICE TO PROCEED IS RECEIVED. UNLESS OTHERWISE SPECIFIED, THE FULLY EXECUTED PURCHASE ORDER WILL BE CONSIDERED NOTICE TO PROCEED. | | |
| | | | | CANCELLATION: THE DIRECTOR OF PURCHASING RESERVES THE RIGHT TO CANCEL THIS CONTRACT IMMEDIATELY UPON WRITTEN NOTICE TO THE VENDOR IF THE MATERIALS OR WORKMANSHIP SUPPLIED ARE OF AN INFERIOR QUALITY OR DO NOT CONFORM | | |

SEE REVERSE SIDE FOR TERMS AND CONDITIONS

| | | |
|--------------------------------|----------------------------------|-----------------------------------|
| SIGNATURE <i>T.L. Smith</i> | TELEPHONE 304-865-9292 | DATE 9/25/07 |
| TITLE owner | FEIN 55-064-0887 | ADDRESS CHANGES TO BE NOTED ABOVE |

WHEN RESPONDING TO RFQ, INSERT NAME AND ADDRESS IN SPACE ABOVE LABELED 'VENDOR'



State of West Virginia
 Department of Administration
 Purchasing Division
 2019 Washington Street East
 Post Office Box 50130
 Charleston, WV 25305-0130

Request for Quotation

RFQ NUMBER
DEFK8052

PAGE
2

ADDRESS CORRESPONDENCE TO ATTENTION OF:
JOHN ABBOTT
304-558-2544

RFQ COPY
 TYPE NAME/ADDRESS HERE

VENDOR

SHIP TO

DIV ENGINEERING & FACILITIES
ARMORY BOARD SECTION

1707 COONSKIN DRIVE
CHARLESTON, WV
25311-1099 341-6368

| DATE PRINTED | TERMS OF SALE | SHIP VIA | F.O.B. | FREIGHT TERMS |
|-------------------|---------------|----------|--------|---------------|
| 08/22/2007 | | | | |

BID OPENING DATE: **09/20/2007** BID OPENING TIME **01:30PM**

| LINE | QUANTITY | UOP | CAT NO | ITEM NUMBER | UNIT PRICE | AMOUNT |
|--|----------|-----|--------|-------------|------------|--------|
| | | | | | | |
| <p>WITH THE SPECIFICATIONS OF THE BID AND CONTRACT HERE IN.</p> <p>WAGE RATES: THE CONTRACTOR OR SUBCONTRACTOR SHALL PAY THE HIGHER OF THE U.S. DEPARTMENT OF LABOR MINIMUM WAGE RATES AS ESTABLISHED FOR KANAWHA COUNTY, PURSUANT TO WEST VIRGINIA CODE 21-5A, ET, SEQ. (PREVAILING WAGE RATES APPLY TO THIS PROJECT)</p> <p>ARBITRATION: ANY REFERENCES MADE TO ARBITRATION OR INTEREST FOR PAYMENTS DUE (EXCEPT FOR ANY INTEREST REQUIRED BY STATE LAW) CONTAINED IN THIS CONTRACT OR IN ANY AMERICAN INSTITUTE OF ARCHITECTS DOCUMENTS PERTAINING TO THIS CONTRACT ARE HEREBY DELETED.</p> <p>WORKERS' COMPENSATION: VENDOR IS REQUIRED TO PROVIDE A CERTIFICATE FROM WORKERS' COMPENSATION IF SUCCESSFUL.</p> <p>ALL OF THE ITEMS CHECKED BELOW WILL BE A REQUIREMENT OF THIS CONTRACT:</p> <p>(XX) INSURANCE: SUCCESSFUL VENDOR SHALL FURNISH PROOF OF COMMERCIAL GENERAL LIABILITY INSURANCE PRIOR TO ISSUANCE OF CONTRACT. UNLESS OTHERWISE SPECIFIED IN THE BID DOCUMENTS, THE MINIMUM AMOUNT OF INSURANCE COVERAGE REQUIRED IS \$250,000.</p> <p>() BUILDERS RISK INSURANCE: SUCCESSFUL VENDOR SHALL FURNISH PROOF OF BUILDERS RISK - ALL RISK INSURANCE IN AN AMOUNT EQUAL TO 100% OF THE AMOUNT OF THE CONTRACT.</p> <p>(XX) BONDS: FIVE PERCENT (5%) OF THE TOTAL AMOUNT OF THE BID PAYABLE TO THE STATE OF WEST VIRGINIA, SHALL BE SUBMITTED WITH EACH BID AS A BID BOND. THE SUCCESSFUL BIDDER SHALL ALSO FURNISH A PERFORMANCE BOND AND LABOR/MATERIAL BOND FOR 100% OF THE AMOUNT OF THE CONTRACT.</p> | | | | | | |

SEE REVERSE SIDE FOR TERMS AND CONDITIONS

| | | |
|---------------------------------|----------------------------------|-----------------------------------|
| SIGNATURE <i>[Signature]</i> | TELEPHONE 304-865-9292 | DATE 9/25/07 |
| TITLE OWNER | FEIN 55-064-0887 | ADDRESS CHANGES TO BE NOTED ABOVE |

WHEN RESPONDING TO RFQ, INSERT NAME AND ADDRESS IN SPACE ABOVE LABELED 'VENDOR'



State of West Virginia
 Department of Administration
 Purchasing Division
 2019 Washington Street East
 Post Office Box 50130
 Charleston, WV 25305-0130

Request for Quotation

RFQ NUMBER
DEFK8052

PAGE
3

ADDRESS CORRESPONDENCE TO ATTENTION OF
JOHN ABBOTT
304-558-2544

RFQ COPY
 TYPE NAME/ADDRESS HERE

VENDOR

SHIP TO

DIV ENGINEERING & FACILITIES
ARMORY BOARD SECTION

1707 COONSKIN DRIVE
CHARLESTON, WV
25311-1099 341-6368

| | | | | |
|-----------------------------------|---------------|----------|--------|---------------|
| DATE PRINTED 08/22/2007 | TERMS OF SALE | SHIP VIA | F.O.B. | FREIGHT TERMS |
|-----------------------------------|---------------|----------|--------|---------------|

BID OPENING DATE: **09/20/2007** BID OPENING TIME **01:30PM**

| LINE | QUANTITY | UOP | CAT. NO. | ITEM NUMBER | UNIT PRICE | AMOUNT |
|---|----------|-----|----------|-------------|------------|--------|
| | | | | | | |
| <p>BONDS MAY BE PROVIDED IN THE FORM OF A CERTIFIED CHECK, IRREVOCABLE LETTER OF CREDIT, OR BOND FURNISHED BY A SOLVENT SURETY COMPANY AUTHORIZED TO DO BUSINESS IN THE STATE OF WEST VIRGINIA. A LETTER OF CREDIT SUBMITTED IN LIEU OF A PERFORMANCE AND LABOR & MATERIAL BOND WILL ONLY BE ALLOWED FOR PROJECTS UNDER \$100,000. PERSONAL OR BUSINESS CHECKS ARE NOT ACCEPTABLE IN LIEU OF THE 5% BID BOND, PERFORMANCE BOND, OR LABOR AND MATERIAL BOND.</p> <p>() MAINTENANCE BOND: A TWO (2) YEAR MAINTENANCE BOND COVERING THE ROOFING SYSTEM WILL BE A REQUIREMENT OF THE SUCCESSFUL VENDOR.</p> <p>REV. 11/00</p> <p>EXHIBIT 7</p> <p>DOMESTIC ALUMINUM, GLASS & STEEL IN PUBLIC WORKS PROJECTS</p> <p>IN ACCORDANCE WITH WEST VIRGINIA CODE 5-19-1 ET., SEQ., EVERY CONTRACT FOR CONSTRUCTION, RECONSTRUCTION, ALTERATION, REPAIR, IMPROVEMENT OR MAINTENANCE OF PUBLIC WORKS, WHERE THE COST IS MORE THAN \$50,000 AND, IN THE CASE OF STEEL ONLY, WHERE THE COST OF STEEL IS MORE THAN \$50,000 OR WHERE MORE THAN 10,000 POUNDS OF STEEL ARE REQUIRED, THE STATE WILL ACCEPT ONLY ALUMINUM GLASS, OR STEEL PRODUCTS PRODUCED IN THE UNITED STATES IN ADDITION, ITEMS OF MACHINERY OR EQUIPMENT PURCHASED FOR USE AT THE SITE OF PUBLIC WORKS SHALL BE MADE OF DOMESTIC ALUMINUM, GLASS OR STEEL, UNLESS THE COST OF THE PRODUCT IS LESS THAN \$50,000 OR LESS THAN 10,000 POUNDS OF STEEL ARE USED IN PUBLIC WORKS PROJECTS.</p> | | | | | | |

SEE REVERSE SIDE FOR TERMS AND CONDITIONS

| | | |
|---------------------------------|----------------------------------|-----------------------------------|
| SIGNATURE <i>[Signature]</i> | TELEPHONE 304-865-9292 | DATE 9/25/07 |
| TITLE Owner | FEIN 55-064-0887 | ADDRESS CHANGES TO BE NOTED ABOVE |

WHEN RESPONDING TO RFQ, INSERT NAME AND ADDRESS IN SPACE ABOVE LABELED 'VENDOR'



State of West Virginia
 Department of Administration
 Purchasing Division
 2019 Washington Street East
 Post Office Box 50130
 Charleston, WV 25305-0130

Request for Quotation

RFO NUMBER
DEFK8052

PAGE
4

ADDRESS CORRESPONDENCE TO ATTENTION OF
JOHN ABBOTT
304-558-2544

RFQ COPY
 TYPE NAME/ADDRESS HERE

SHIP TO

SHIP TO

DIV ENGINEERING & FACILITIES
ARMORY BOARD SECTION

1707 COONSKIN DRIVE
CHARLESTON, WV
25311-1099 341-6368

| | | | | |
|-----------------------------------|---------------|----------|--------|---------------|
| DATE PRINTED 08/22/2007 | TERMS OF SALE | SHIP VIA | F.O.B. | FREIGHT TERMS |
|-----------------------------------|---------------|----------|--------|---------------|

BID OPENING DATE: **09/20/2007** BID OPENING TIME **01:30PM**

| LINE | QUANTITY | UOP | CAT NO | ITEM NUMBER | UNIT PRICE | AMOUNT |
|---|----------|-----|--------|-------------|------------|--------|
| | | | | | | |
| <p>FOREIGN MADE ALUMINUM, GLASS OR STEEL PRODUCTS MAY BE ACCEPTED ONLY IF THE COST OF DOMESTIC PRODUCTS IS FOUND TO BE UNREASONABLE. SUCH COST IS UNREASONABLE IF IT IS 20% OR MORE HIGHER THAN THE BID PRICE FOR FOREIGN MADE PRODUCTS. IF THE DOMESTIC ALUMINUM, GLASS OR STEEL PRODUCTS TO BE SUPPLIED OR PRODUCED IN A "SUBSTANTIAL LABOR SURPLUS AREA", AS DEFINED BY THE UNITED STATES DEPARTMENT OF LABOR, FOREIGN PRODUCTS MAY BE SUPPLIED ONLY IF DOMESTIC PRODUCTS ARE 30% OR MORE HIGHER IN PRICE THAN THE FOREIGN MADE PRODUCTS.</p> <p>IF, PRIOR TO THE AWARD OF A CONTRACT UNDER THE ABOVE PROVISIONS, THE SPENDING OFFICER OF THE SPENDING UNIT DETERMINES THAT THERE EXISTS A BID FOR LIKE FOREIGN ALUMINUM, GLASS OR STEEL THAT IS REASONABLE AND LOWER THAN THE LOWEST BID DOMESTIC PRODUCTS, THE SPENDING OFFICE MAY REQUEST, IN WRITING, A REEVALUATION AND REDUCTION IN THE LOWEST BID FOR SUCH DOMESTIC PRODUCTS ALL VENDORS MUST INDICATE IN THEIR BID IF THEY ARE SUPPLYING FOREIGN ALUMINUM, GLASS OR STEEL.</p> <p>REV. 3/88</p> <p>EXHIBIT 9</p> <p>NOTICE FOR ISSUANCE & ACKNOWLEDGEMENT OF CONSTRUCTION PROJECT ADDENDA</p> <p>THE ARCHITECT/ENGINEER AND/OR AGENCY SHALL BE REQUIRED TO ABIDE BY THE FOLLOWING SCHEDULE IN ISSUING CONSTRUCTION PROJECT ADDENDA FOR STATE AGENCIES:</p> <p>(1) THE ARCHITECT/ENGINEER SHALL PREPARE THE ADDENDUM AND A LIST OF ALL PARTIES THAT HAVE PROCURED DRAWINGS AND SPECIFICATIONS FOR THE PROJECT. THE ADDENDUM</p> | | | | | | |

SEE REVERSE SIDE FOR TERMS AND CONDITIONS

| | | |
|---------------------------------|----------------------------------|-----------------------------------|
| SIGNATURE <i>[Signature]</i> | TELEPHONE 304-865-9292 | DATE 9/25/07 |
| TITLE owner | FEIN 55-064-0887 | ADDRESS CHANGES TO BE NOTED ABOVE |

WHEN RESPONDING TO RFQ, INSERT NAME AND ADDRESS IN SPACE ABOVE LABELED 'VENDOR'



State of West Virginia
 Department of Administration
 Purchasing Division
 2019 Washington Street East
 Post Office Box 50130
 Charleston, WV 25305-0130

Request for Quotation

RFQ NUMBER
DEFK8052

PAGE
5

ADDRESS CORRESPONDENCE TO ATTENTION OF
JOHN ABBOTT
304-558-2544

VENDOR

RFQ COPY
 TYPE NAME/ADDRESS HERE

SHIP TO

DIV ENGINEERING & FACILITIES
ARMORY BOARD SECTION

1707 COONSKIN DRIVE
CHARLESTON, WV
25311-1099 341-6368

| | | | | |
|-----------------------------------|---------------|----------|--------|---------------|
| DATE PRINTED 08/22/2007 | TERMS OF SALE | SHIP VIA | F.O.B. | FREIGHT TERMS |
|-----------------------------------|---------------|----------|--------|---------------|

BID OPENING DATE: **09/20/2007** BID OPENING TIME **01:30PM**

| LINE | QUANTITY | UOP | CAT NO | ITEM NUMBER | UNIT PRICE | AMOUNT |
|--|----------|-----|--------|-------------|------------|--------|
| <p>AND LIST SHALL BE FORWARDED TO THE BUYER IN THE STATE PURCHASING DIVISION. THE ARCHITECT/ENGINEER SHALL ALSO SEND A COPY OF THE ADDENDUM TO THE STATE AGENCY FOR WHICH THE CONTRACT IS ISSUED.</p> <p>(2) THE BUYER SHALL SEND THE ADDENDUM TO ALL INTERESTED PARTIES AND, IF NECESSARY, EXTEND THE BID OPENING DATE. ANY ADDENDUM SHOULD BE RECEIVED BY THE BUYER WITHIN FOURTEEN (14) DAYS PRIOR TO THE BID OPENING DATE.</p> <p>(3) ALL ADDENDA SHOULD BE FORMALLY ACKNOWLEDGED BY ALL BIDDERS AND SUBMITTED TO THE STATE PURCHASING DIVISION. THE SAME RULES AND REGULATIONS THAT APPLY TO THE ORIGINAL BIDDING DOCUMENT SHALL ALSO APPLY TO AN ADDENDUM DOCUMENT. THE ONLY EXCEPTION MAY BE FOR AN ADDENDUM THAT IS ISSUED FOR THE SOLE PURPOSE OF CHANGING A BID OPENING TIME AND/OR DATE.</p> <p>REV. 11/96</p> <p>EXHIBIT 10</p> <p>ADDENDUM ACKNOWLEDGEMENT</p> <p>I HEREBY ACKNOWLEDGE RECEIPT OF THE FOLLOWING CHECKED ADDENDUM(S) AND HAVE MADE THE NECESSARY REVISIONS TO MY PROPOSAL, PLANS AND/OR SPECIFICATION, ETC.</p> <p>ADDENDUM NOS.:</p> <p>NO. 1 <input checked="" type="checkbox"/></p> <p>NO. 2 <input type="checkbox"/></p> | | | | | | |

SEE REVERSE SIDE FOR TERMS AND CONDITIONS

| | | |
|---------------------------------|----------------------------------|-----------------------------------|
| SIGNATURE <i>[Signature]</i> | TELEPHONE 304-865-9292 | DATE 9/25/07 |
| TITLE Owner | FAX 55-064-0887 | ADDRESS CHANGES TO BE NOTED ABOVE |

WHEN RESPONDING TO RFQ, INSERT NAME AND ADDRESS IN SPACE ABOVE LABELED 'VENDOR'



State of West Virginia
 Department of Administration
 Purchasing Division
 2019 Washington Street East
 Post Office Box 50130
 Charleston, WV 25305-0130

Request for Quotation

RFQ NUMBER
DEFK8052

PAGE
6

ADDRESS CORRESPONDENCE TO ATTENTION OF
JOHN ABBOTT
304-558-2544

VENDOR

RFQ COPY
 TYPE NAME/ADDRESS HERE

SHIP TO

DIV ENGINEERING & FACILITIES
ARMORY BOARD SECTION

1707 COONSKIN DRIVE
CHARLESTON, WV
25311-1099 341-6368

| DATE PRINTED | TERMS OF SALE | SHIP VIA | F.O.B | FREIGHT TERMS |
|-------------------|---------------|----------|-------|---------------|
| 08/22/2007 | | | | |

BID OPENING DATE: **09/20/2007** BID OPENING TIME **01:30PM**

| LINE | QUANTITY | UOP | CAT NO. | ITEM NUMBER | UNIT PRICE | AMOUNT |
|---|----------|-------|---------|-------------|------------|--------|
| | NO. 3 | | | | | |
| | NO. 4 | | | | | |
| | NO. 5 | | | | | |
| <p>I UNDERSTAND THAT FAILURE TO CONFIRM THE RECEIPT OF THE ADDENDUM(S) MAY BE CAUSE FOR REJECTION OF THE BIDS.</p> <p>..... <i>TL Smith</i>.....SIGNATURE TL SMITH EXCAVATING.....COMPANY 9/25/07.....DATE</p> <p>REV. 11/96</p> <p>CONTRACTORS LICENSE</p> <p>WEST VIRGINIA STATE CODE 21-11-2 REQUIRES THAT ALL PERSONS DESIRING TO PERFORM CONTRACTING WORK IN THIS STATE MUST BE LICENSED. THE WEST VIRGINIA CONTRACTORS LICENSING BOARD IS EMPOWERED TO ISSUE THE CONTRACTORS LICENSE. APPLICATIONS FOR A CONTRACTORS LICENSE MAY BE MADE BY CONTACTING THE WEST VIRGINIA DIVISION OF LABOR CAPITOL COMPLEX, BUILDING 3, ROOM 319, CHARLESTON, WV 25305. TELEPHONE: (304) 558-7890.</p> <p>WEST VIRGINIA STATE CODE 21-11-11 REQUIRES ANY PROSPECTIVE BIDDER TO INCLUDE THE CONTRACTORS LICENSE NUMBER ON THEIR BID.</p> <p>BIDDER TO COMPLETE:</p> | | | | | | |

SEE REVERSE SIDE FOR TERMS AND CONDITIONS

| | | |
|------------------------------|---------------------------|-----------------------------------|
| SIGNATURE <i>TL Smith</i> | TELEPHONE 304-865-9292 | DATE 9/25/07 |
| TITLE owner | FEIN 55-064-0887 | ADDRESS CHANGES TO BE NOTED ABOVE |

WHEN RESPONDING TO RFQ, INSERT NAME AND ADDRESS IN SPACE ABOVE LABELED 'VENDOR'



State of West Virginia
 Department of Administration
 Purchasing Division
 2019 Washington Street East
 Post Office Box 50130
 Charleston, WV 25305-0130

Request for Quotation

RFQ NUMBER
DEFK8052

PAGE
7

ADDRESS CORRESPONDENCE TO ATTENTION OF
JOHN ABBOTT
304-558-2544

VENDOR

RFQ COPY
 TYPE NAME/ADDRESS HERE

SHIP TO

DIV ENGINEERING & FACILITIES
 ARMORY BOARD SECTION
 1707 COONSKIN DRIVE
 CHARLESTON, WV
 25311-1099 341-6368

| | | | | |
|-------------------------------------|---------------|---------------------------------|--------|---------------|
| DATE PRINTED 08/22/2007 | TERMS OF SALE | SHIP VIA | F.O.B. | FREIGHT TERMS |
| BID OPENING DATE: 09/20/2007 | | BID OPENING TIME 01:30PM | | |

| LINE | QUANTITY | UOP | CAT NO | ITEM NUMBER | UNIT PRICE | AMOUNT |
|--|----------|-----|--------|-------------|------------|--------|
| <p>CONTRACTORS NAME: TL SMITH EXCAVATING</p> <p>CONTRACTORS LICENSE NO.: WV 007502</p> <p>THE SUCCESSFUL BIDDER WILL BE REQUIRED TO FURNISH A COPY OF THEIR CONTRACTORS LICENSE PRIOR TO ISSUANCE OF A PURCHASE ORDER/CONTRACT</p> <p>APPLICABLE LAW</p> <p>THE WEST VIRGINIA STATE CODE, PURCHASING DIVISION RULE AND REGULATIONS, AND THE INFORMATION PROVIDED IN THE "REQUEST FOR QUOTATION" ISSUED BY THE PURCHASING DIVISION IS THE SOLE AUTHORITY GOVERNING THIS PROCUREMENT.</p> <p>ANY INFORMATION PROVIDED IN SPECIFICATION MANUALS, OR ANY OTHER SOURCE, VERBAL OR WRITTEN, WHICH CONTRADICTS OR ALTERS THE INFORMATION PROVIDED FROM THE SOURCES AS DESCRIBED IN THE ABOVE PARAGRAPH IS VOID AND OF NO EFFECT.</p> <p>BANKRUPTCY: IN THE EVENT THE VENDOR/CONTRACTOR FILES FOR BANKRUPTCY PROTECTION, THIS CONTRACT IS AUTOMATICALLY NULL AND VOID, AND IS TERMINATED WITHOUT FURTHER ORDER.</p> <p>REV. 1/2005</p> <p>NOTICE</p> <p>A SIGNED BID MUST BE SUBMITTED TO:</p> <p>DEPARTMENT OF ADMINISTRATION</p> | | | | | | |

SEE REVERSE SIDE FOR TERMS AND CONDITIONS

| | | |
|---------------------------------|----------------------------------|-----------------------------------|
| SIGNATURE <i>[Signature]</i> | TELEPHONE 304 865 9292 | DATE 9/25/07 |
| TITLE Owner | FEIN 55-064-0887 | ADDRESS CHANGES TO BE NOTED ABOVE |

WHEN RESPONDING TO RFQ, INSERT NAME AND ADDRESS IN SPACE ABOVE LABELED 'VENDOR'



State of West Virginia
 Department of Administration
 Purchasing Division
 2019 Washington Street East
 Post Office Box 50130
 Charleston, WV 25305-0130

Request for Quotation

RFQ NUMBER
DEFK8052

PAGE
8

ADDRESS CORRESPONDENCE TO ATTENTION OF
JOHN ABBOTT
304-558-2544

RFQ COPY
 TYPE NAME/ADDRESS HERE

VENDOR

SHIP TO

DIV ENGINEERING & FACILITIES
ARMORY BOARD SECTION

1707 COONSKIN DRIVE
CHARLESTON, WV
25311-1099 341-6368

| DATE PRINTED | TERMS OF SALE | SHIP VIA | F.O.B. | FREIGHT TERMS |
|--------------|---------------|----------|--------|---------------|
| 08/22/2007 | | | | |

BID OPENING DATE: **09/20/2007** BID OPENING TIME **01:30PM**

| LINE | QUANTITY | UOP | CAT NO | ITEM NUMBER | UNIT PRICE | AMOUNT |
|---|----------|-----|--------|-------------|------------|--------|
| | | | | | | |
| <p>PURCHASING DIVISION BUILDING 15 2019 WASHINGTON STREET, EAST CHARLESTON, WV 25305-0130</p> <p>THE BID SHOULD CONTAIN THIS INFORMATION ON THE FACE OF THE ENVELOPE OR THE BID MAY NOT BE CONSIDERED:</p> <p>SEALED BID</p> <p>BUYER: JOHN ABBOTT</p> <p>REQ. NO.: DEFK8052</p> <p>BID OPENING DATE: 9/20/2007</p> <p>BID OPENING TIME: 1:30 PM</p> <p>PLEASE PROVIDE A FAX NUMBER IN CASE IT IS NECESSARY TO CONTACT YOU REGARDING YOUR BID: 304-865-9293</p> <p>PLEASE PRINT OR TYPE NAME OF PERSON TO CONTACT CONCERNING THIS QUOTE: TERRY L SMITH</p> | | | | | | |

SEE REVERSE SIDE FOR TERMS AND CONDITIONS

| | | |
|-----------------------------------|----------------------------------|-----------------------------------|
| SIGNATURE <i>Terry L Smith</i> | TELEPHONE 304 865-9292 | DATE 9/25/07 |
| TITLE owner | FEIN 55-064-0887 | ADDRESS CHANGES TO BE NOTED ABOVE |

WHEN RESPONDING TO RFQ, INSERT NAME AND ADDRESS IN SPACE ABOVE LABELED 'VENDOR'



State of West Virginia
 Department of Administration
 Purchasing Division
 2019 Washington Street East
 Post Office Box 50130
 Charleston, WV 25305-0130

Request for Quotation

| |
|------------|
| RFQ NUMBER |
| DEFK8052 |

| |
|------|
| PAGE |
| 9 |

| |
|---|
| ADDRESS CORRESPONDENCE TO ATTENTION OF: |
| JOHN ABBOTT 304-558-2544 |

VENDOR

RFQ COPY
 TYPE NAME/ADDRESS HERE

SHIP TO

DIV ENGINEERING & FACILITIES
 ARMORY BOARD SECTION
 1707 COONSKIN DRIVE
 CHARLESTON, WV
 25311-1099 341-6368

| | | | | |
|------------------------------|---------------|--------------------------|--------|---------------|
| DATE PRINTED | TERMS OF SALE | SHIP VIA | F.O.B. | FREIGHT TERMS |
| 08/22/2007 | | | | |
| BID OPENING DATE: 09/20/2007 | | BID OPENING TIME 01:30PM | | |

| LINE | QUANTITY | UOP | CAT NO | ITEM NUMBER | UNIT PRICE | AMOUNT |
|--|----------|-----|--------|-------------|------------|--------------------------------|
| ***** THIS IS THE END OF RFQ DEFK8052 ***** TOTAL: | | | | | | <u>\$292,360.⁰⁰</u> |

SEE REVERSE SIDE FOR TERMS AND CONDITIONS

| | | |
|--------------------|--------------|-----------------------------------|
| SIGNATURE | TELEPHONE | DATE |
| <i>[Signature]</i> | 304 865-9292 | 9/25/07 |
| TITLE | FEIN | ADDRESS CHANGES TO BE NOTED ABOVE |
| owner | 55-064-0887 | |

WHEN RESPONDING TO RFQ, INSERT NAME AND ADDRESS IN SPACE ABOVE LABELED 'VENDOR'

**JOINT FORCES HEADQUARTERS BARRIER INSTALLATION
WEST VIRGINIA ARMY NATIONAL GUARD (WVARNG)
1703 COONSKIN DRIVE
CHARLESTON, WV 25311**

1.0 INTRODUCTION

JFHQ is made-up of several buildings and facilities on both sides of Coonskin Drive. The WVARNG intends to reinforce the existing natural or man-made obstacles using a system of concrete and post and cable barriers to provide for a more secure environment

2.0 LOCATION

JFHQ is located on Coonskin Drive prior to entry to Coonskin Park. Coonskin Drive and the buildings are relatively level through the site though the facilities are generally located several feet above the elevation of the road.

3.0 SCOPE / OBJECTIVE

It is the desire of the WVARNG to install a functional barrier system that can be easily maintained, won't detract from the appearance of facilities, and may be modified or removed at a later date and will use the slope between our facilities and Coonskin Drive and incorporates previously installed barriers and gates.

4.0 REQUIREMENTS AND SPECIFICATIONS.

4.1 Project Specific:

4.1.1 Site: The attached schematic is an approximation provided for general information (See Attachment 3). The awarded contractor will be responsible for field measuring all distances and surveyor support as needed. These specifications include reference to Carr Concrete Protector Guard Wall CCC-PGW-100 or like item (See Attachment 1). If used as part of a bid, a submittal for like items must be included that lists materials, dimensions, weight, method of handling, finish, means of manufacture, and manufacture lead-time. Barriers are intended to be parallel or perpendicular to Coonskin Drive whenever possible and generally aligned to one-another. Installation may require modification to specified length of individual barriers.

4.1.2 Concrete Barrier System: The barrier system will be of modular concrete design consistent with Carr Concrete Protector Guard Wall CCC-PGW-100. Installation will be consistent with attached design and will generally be imbedded in slope. All sections will be placed on excavated and compacted soil with a 4" topping of compacted gravel. The excavation will be accomplished so that cut will equal the amount of material needed to fill the up-slope side of the section level to the top (No material is to be removed from the site without consent from the WVARNG) (See Attachment 2).

4.1.3 Runs: A 4' gap, outside edge to outside edge, will be left between stairwell and wall, gatepost and wall, and breaks in wall runs. Continuous lengths of wall run should be no greater than 70'. Barrier segments will begin and end in a post.

4.1.4 Seeding: The contractor will seed, fertilize, and mulch all disturbed areas and will submit fertilizer and seed content for approval prior to application.

4.1.5 Erosion: The contractor is responsible for developing and submitting runoff and erosion control measures or permits as necessary.

4.1.6 Funding: This project is based upon availability of funding; sum or all of the segments in Attachment 3 may represent the final scope of this project.

4.2 General

4.2.1. Construction will follow all national and state building codes.

4.2.2. The developed and approved design will be utilized for all construction.

4.2.3. All construction will result in a complete and functional system unless noted otherwise.

4.2.4. All construction activities will be in conjunction with OSHA, Safety and Health Requirements Manual (US Army Corps of Engineers) and FFA. As noted, the Army safety and health standards mirror OSHA. All construction activities on site will be a hardhat area and marked as such.

4.2.5. Access to the site will be restricted and controlled by the Contractor. A visitor's sign-in and hardhats are to be made available for personnel visiting site.

4.2.6. Fueling and open flame: Any operation will be maintained in accordance with OSHA and WV Fire Marshall Standards to included secondary containment, fire extinguishers, and spill control.

4.2.7. Cleanup is required daily. No open dumps of construction materials. Remove surplus soil material, unsuitable topsoil, obstructions, demolished materials, and waste materials including trash and debris, and legally dispose of them off Owner's property. Consideration will be given to relocating crushed pavement, gravel and clean soil on the property with the owner's permission.

4.2.8 Contractor is responsible for keeping driveways and entrances serving the premises clear and available for the Owner's use.

4.2.9 Repair to damaged structures, contents, and surrounding grounds will be the contractor's responsibility.

4.2.10 The contractor shall not use WVARNG facilities without prior approval; this includes dumpsters, restrooms, phones, or utilities.

4.2.11 Contractor shall coordinate storage of materials and equipment park locations with the WVARNG.

4.2.12 WVARNG sites are secure. Coordination must be made for all personnel, equipment, materials, deliveries, and sub-contractors. ID such as a driver's license is required. All personnel and vehicles are subject to search.

4.2.13 All work will be supervised. The WVARNG will be provided the name of the on-site person in charge with a means of immediate contact.

4.2.14 The contractor is responsible for paying current and applicable prevailing wage rates and providing certified payrolls as directed.

4.2.15 In accordance with FAR 11.504(b) and DFARS 211.504(b), liquidated damages will be assessed for each calendar day required to complete the construction work on this project past the scheduled completion date. The contractor has complete control of the pace of work. Liquidated damages shall be assessed at a rate of \$1,345.13 as follows:

| ITEM | Daily Costs | Notes |
|-------------------------------------|--------------------|--|
| Project Management | | |
| Project Manager | \$ 412.39 | Based upon 8 hours per day at \$51.55/hr |
| Transportation Costs | \$ 131.25 | Based upon 350 miles round trip at \$.375/mile |
| Subtotal cost per Day | \$ 543.64 | |
| Procurement | | |
| Contracting Officer | \$ 412.39 | Based upon 8 hours per day at \$51.55/hr |
| Contract Administrator | \$ 340.35 | Based upon 8 hours per day at \$42.54/hr |
| Transportation Costs | \$ 48.75 | Based upon 130 miles round trip at \$.375/mile |
| Subtotal cost per Day | \$ 801.49 | |
| Total for Liquidated Damages | \$ 1,345.13 | |

5. DATES

Mandatory Prebid Conference

09/14/2007

6.0 MEETINGS AND REVIEWS

6.1 A mandatory prebid conference shall be conducted on the date specified above at the Drill Hall, WV Army National Guard Complex, 1703 Coonskin Drive, Charleston, WV. The Drill Hall is the first brick building on the left after going by the Air National Guard. Potential bidders will park in Visitor's Parking and will enter the glass doors on the end of the building and under the overhang. All interested bidders are required to be present at this meeting. Failure to attend the mandatory prebid conference shall automatically result in disqualification. No one person can represent more than one vendor.

6.2 Prior to initiation of work, the contractor shall meet with the WVARNG. The Contractor will provide weekly updates to Post Engineering during contract period.

7.0 SPECIAL CONSIDERATIONS

The contractors shall coordinate all work with the WVARNG. This will include scheduling work to avoid conflicts with operations. Prior arrangements must be made to work outside work hours. Normal work hours for this location are 7:30 am to 4:00 pm Monday – Friday.

It is the designated contractor's responsibility to conduct all activities in a manner that ensures the safety of crewmembers and avoids damage to vehicles and property of the WVARNG.

8.0 PERIOD OF SERVICE

Construction contractor will have 16 weeks to complete construction upon receipt of Notice to Proceed.

9.0 FINAL INSPECTION AND ACCEPTANCE: Completion of work upon agreement by contractor and WVARNG.

10.0 Bids

Bid Form:

| Item | Description | Estimated Quantities | Unit Price Per Linear Foot | Total Cost |
|-----------|----------------------------|----------------------|----------------------------|---------------------------|
| Base Item | Installed Concrete Barrier | 2,000' | \$ 146. ¹⁸ | \$ 292,365. ⁰⁰ |

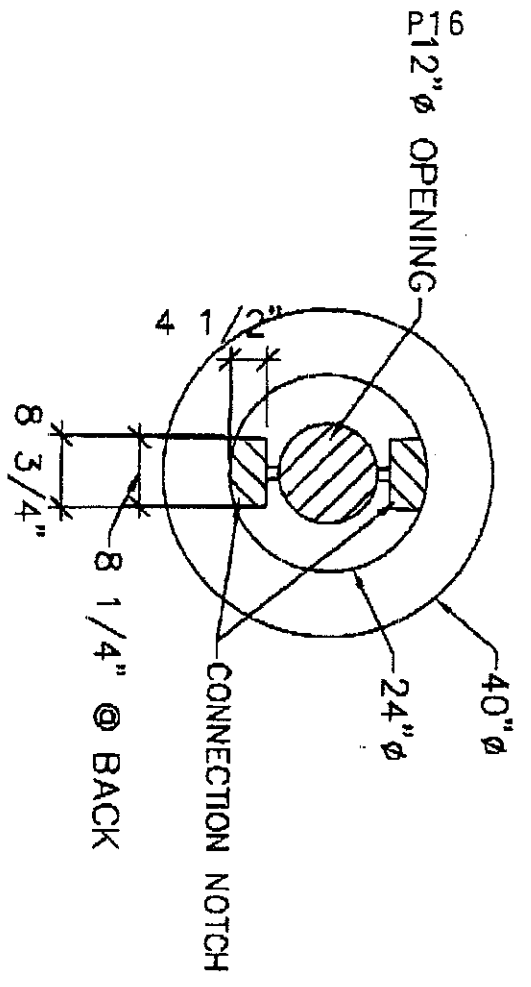

PLAN VIEW

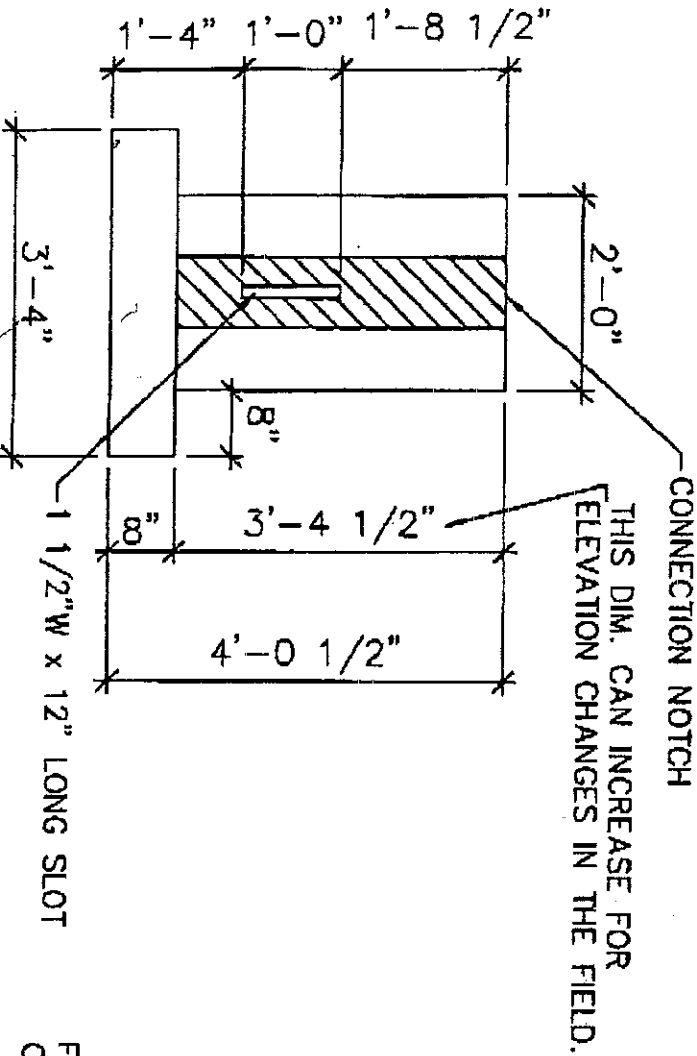

ELEVATION VIEW

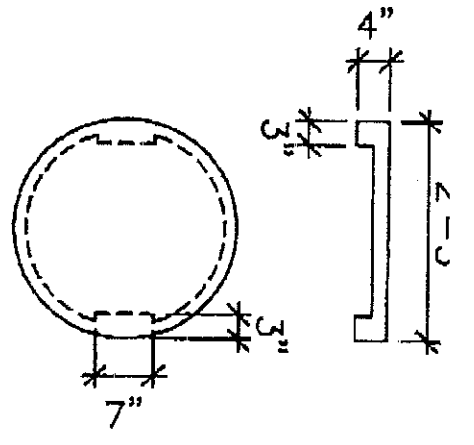

CAP DETAIL

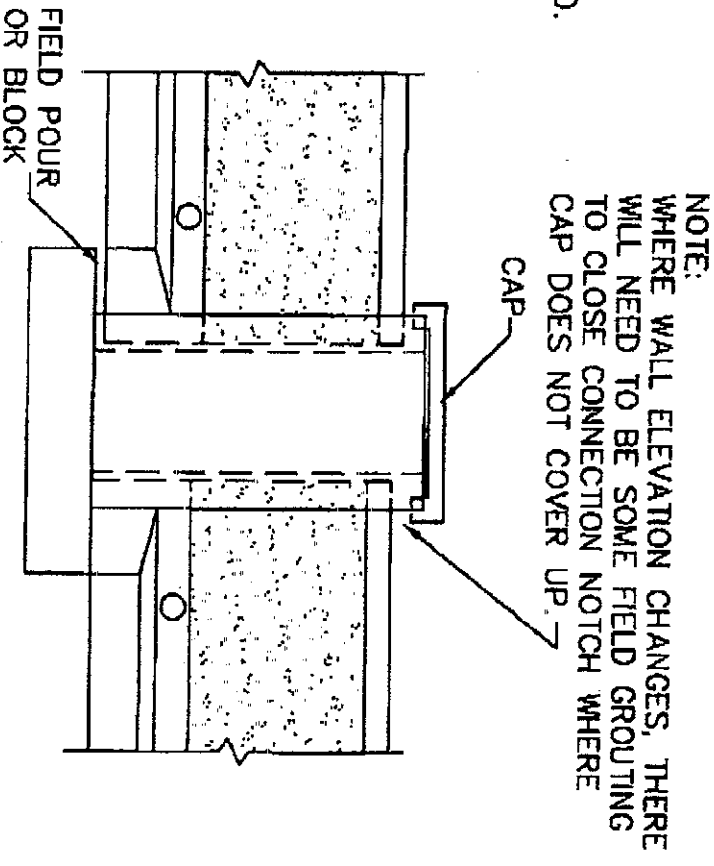

CARR CONCRETE
 CARR CONCRETE CORPORATION
 P.O. BOX 265
 WAVERLY, WV, 26184-0265

PHONE: 800-837-8918
 FAX: 504-464-4013

| | |
|----------------|------------------------|
| PROJECTOR | GUARD WALL CCC-PGW-100 |
| DESIGNER | WVARNG |
| CHARLESTON, WV | |
| DATE | 6-13-07 |
| REV | |
| DATE | |

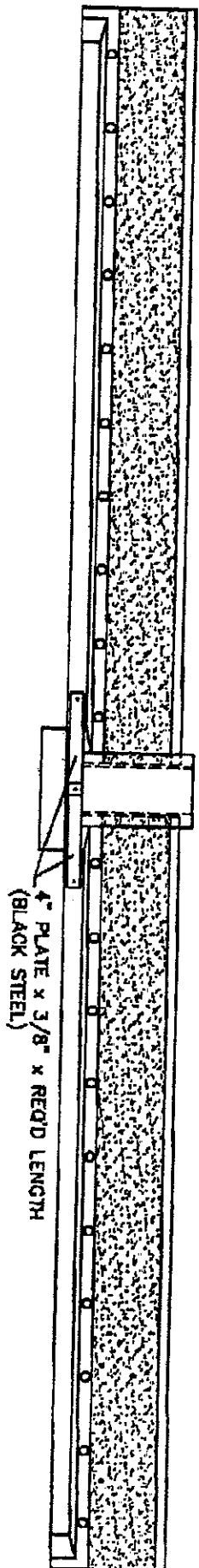

ELEVATION VIEW

4" PLATE x 3/8" x REQ'D LENGTH
(BLACK STEEL)

FIELD DRILL AND INSTALL CHINCH ANCHORS

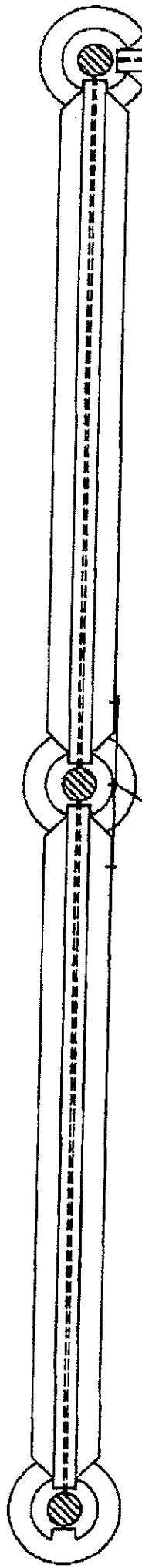

PLAN VIEW



CARR CONCRETE
 CARR CONCRETE CORPORATION
 P.O. BOX 285
 WAVERLY, WV 26184-0285
 PHONE: 800-837-8918
 FAX: 304-464-4013

| | | | | |
|----------------------------------|--------------------|-------|---------|--|
| PROTECTOR GUARD WALL CCC-PGW-100 | | DRAWN | 3 | |
| WYARNG | | DATE | 6-13-07 | |
| CHARLESTON, WV | | REV | 1 | |
| FILE# | DRAWN BY: J MORRIS | DATE | 6-13-07 | |

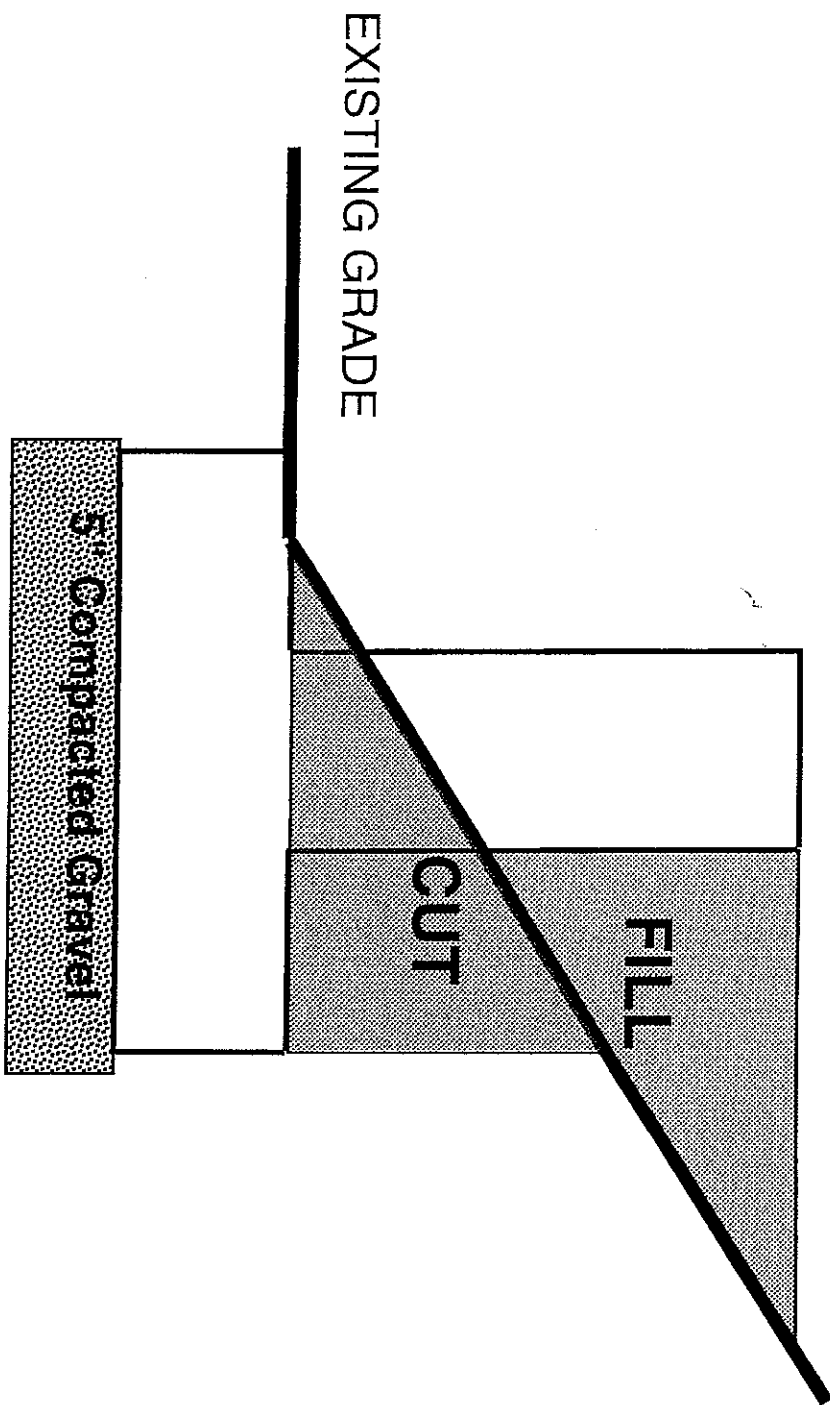

WV ARMY NATIONAL GUARD BARRIER PLAN
COONSKIN DRIVE, CHARLESTON, WV 25311

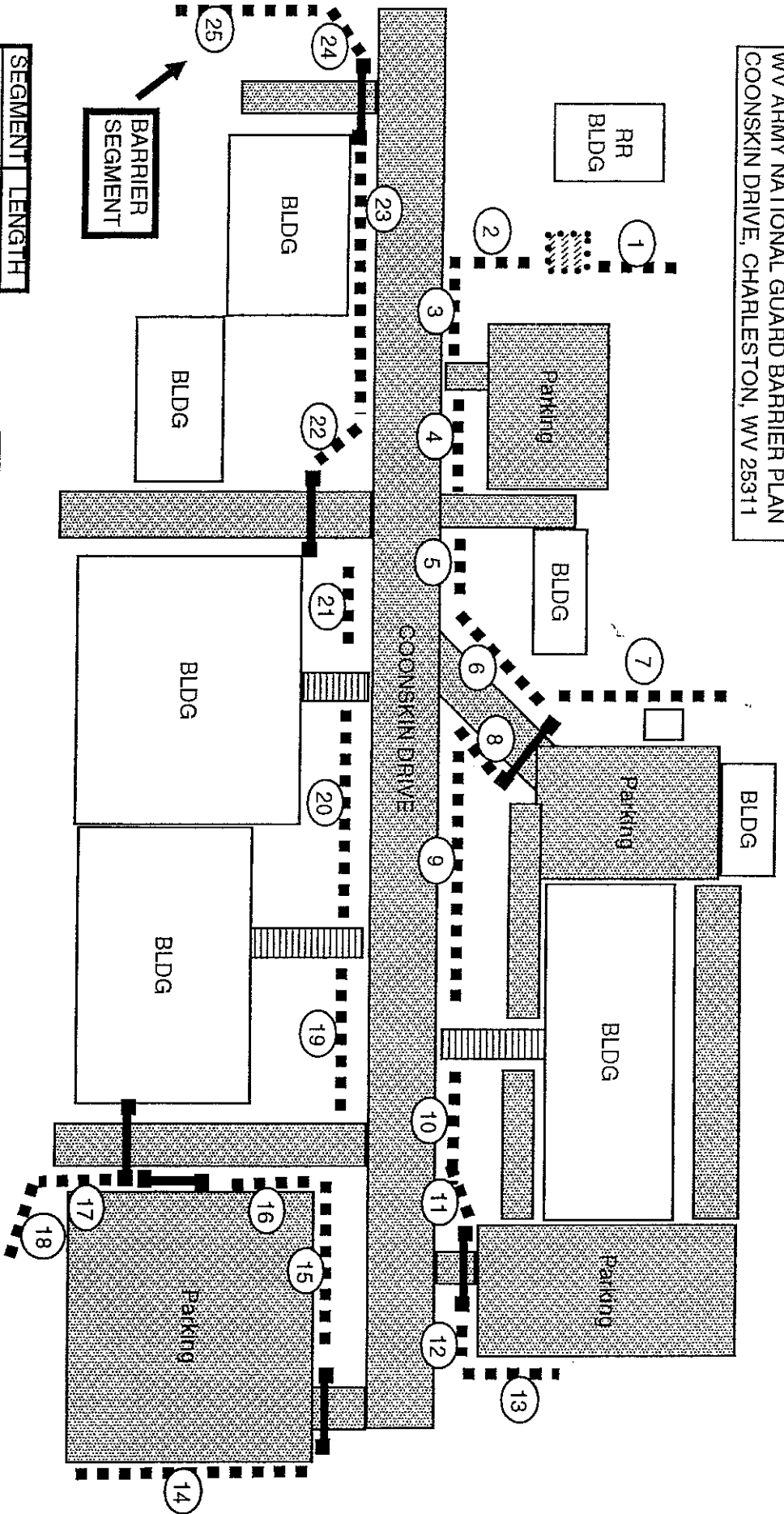

| SEGMENT | LENGTH |
|---------|--------|
| 1 | 40 |
| 2 | 20 |
| 3 | 15 |
| 4 | 20 |
| 5 | 100 |
| 6 | 110 |
| 7 | 125 |
| 8 | 80 |
| 9 | 320 |

| SEGMENT | LENGTH |
|---------|--------|
| 10 | 200 |
| 11 | 35 |
| 12 | 26 |
| 13 | 100 |
| 14 | 40 |
| 15 | 170 |
| 16 | 40 |
| 17 | 20 |

| SEGMENT | LENGTH |
|---------|--------|
| 18 | 75 |
| 19 | 140 |
| 20 | 160 |
| 21 | 110 |
| 22 | 40 |
| 23 | 200 |
| 24 | 50 |
| 25 | 100 |

| | |
|--------------|-------------|
| TOTAL | 2396 |
|--------------|-------------|

STATE OF WEST VIRGINIA
Purchasing Division

PURCHASING AFFIDAVIT

West Virginia Code §5A-3-10a states: No contract or renewal of any contract may be awarded by the state or any of its political subdivisions to any vendor or prospective vendor when the vendor or prospective vendor or a related party to the vendor or prospective vendor is a debtor and the debt owned is an amount greater than one thousand dollars in the aggregate

DEFINITIONS:

“Debt” means any assessment, premium, penalty, fine, tax or other amount of money owed to the state or any of its political subdivisions because of a judgment, fine, permit violation, license assessment, defaulted workers’ compensation premium, penalty or other assessment presently delinquent or due and required to be paid to the state or any of its political subdivisions, including any interest or additional penalties accrued thereon.

“Debtor” means any individual, corporation, partnership, association, limited liability company or any other form or business association owing a debt to the state or any of its political subdivisions. “Political subdivision” means any county commission; municipality; county board of education; any instrumentality established by a county or municipality; any separate corporation or instrumentality established by one or more counties or municipalities, as permitted by law; or any public body charged by law with the performance of a government function or whose jurisdiction is coextensive with one or more counties or municipalities. “Related party” means a party, whether an individual, corporation, partnership, association, limited liability company or any other form or business association or other entity whatsoever, related to any vendor by blood, marriage, ownership or contract through which the party has a relationship of ownership or other interest with the vendor so that the party will actually or by effect receive or control a portion of the benefit, profit or other consideration from performance of a vendor contract with the party receiving an amount that meets or exceed five percent of the total contract amount.

EXCEPTION: The prohibition of this section does not apply where a vendor has contested any tax administered pursuant to chapter eleven of this code, workers’ compensation premium, permit fee or environmental fee or assessment and the matter has not become final or where the vendor has entered into a payment plan or agreement and the vendor is not in default of any of the provisions of such plan or agreement.

LICENSING: Vendors must be licensed and in good standing in accordance with any and all state and local laws and requirements by any state or local agency of West Virginia, including, but not limited to, the West Virginia Secretary of State’s Office, the West Virginia Tax Department, West Virginia Insurance Commission, or any other state agencies or political subdivision. Furthermore, the vendor must provide all necessary releases to obtain information to enable the Director or spending unit to verify that the vendor is licensed and in good standing with the above entities.

CONFIDENTIALITY: The vendor agrees that he or she will not disclose to anyone, directly or indirectly, any such personally identifiable information or other confidential information gained from the agency, unless the individual who is the subject of the information consents to the disclosure in writing or the disclosure is made pursuant to the agency’s policies, procedures and rules. Vendors should visit www.state.wv.us/admin/purchase/privacy for the Notice of Agency Confidentiality Policies.

Under penalty of law for false swearing (West Virginia Code, §61-5-3), it is hereby certified that the vendor acknowledges the information in this said affidavit and are in compliance with the requirements as stated.

Vendor's Name: TL SMITH EXCAVATING

Authorized Signature:  Date: 9/25/07



4700 MacCorkle Ave. S.E. Charleston, West Virginia 25304

PRODUCER:

BrickStreet Mutual Insurance Company
4700 MacCorkle Ave., S.E.
Charleston, WV 25304

CERTIFICATE HOLDER:

TERRY L SMITH
357 OLD ST MARYS PIKE
PARKERSBURG, WEST VIRGINIA, 26104-9730

INSURED:

TERRY L SMITH
357 OLD ST MARYS PIKE
PARKERSBURG, WEST VIRGINIA, 26104-9730

CERTIFICATE OF INSURANCE

The policy of insurance listed below has been issued to the insured named above for the policy period and coverage indicated. This certificate is issued as a matter of information only and confers no rights upon the certificate holder. This certificate does not amend, extend or alter the coverage afforded by the policy below. Coverage is contingent on the insured's compliance with policy conditions and premium payment.

If the policy is canceled before the expiration date, BrickStreet Mutual Insurance Company will endeavor to mail a written notice to the certificate holder within 30 days of cancellation. Failure to mail the notice shall impose no obligation or liability of any kind upon BrickStreet Mutual Insurance Company.

POLICY NUMBER: WC10029727-04

DATE CERTIFICATE ISSUED: 09/25/2007

POLICY EFFECTIVE DATE: 09/24/2007

EXPIRATION DATE: 09/24/2008

WORKERS COMPENSATION AND EMPLOYERS LIABILITY

LIMITS / COVERAGE

WORKERS COMPENSATION - STATUTORY LIMITS

EMPLOYERS LIABILITY LIMITS:

| | | |
|-----------------------------------|----------------------|----------------------|
| BODILY INJURY BY ACCIDENT: | \$ 100,000.00 | EACH ACCIDENT |
| BODILY INJURY BY DISEASE: | \$ 500,000.00 | POLICY LIMIT |
| BODILY INJURY BY DISEASE: | \$ 100,000.00 | EACH EMPLOYEE |

**WV BROAD FORM EMPLOYERS LIABILITY ENDORSEMENT -
COVERAGE FOR WV CODE 23-4-2(d)(2)(ii)**

**FEDERAL COAL MINE HEALTH AND SAFETY ACT COVERAGE ENDORSEMENT -
COVERAGE FOR WV CODE 23-4b-1 - FEDERAL BLACK LUNG COVERAGE**

SPECIAL PROVISIONS IF ANY:

CONTRACTOR LICENSE

Authorized by the

West Virginia Contractor Licensing Board

Number: WV007502

Classification:

SPECIALTY

T. L. SMITH, EXCAVATING
357 OLD ST. MARY PIKE
PARKERSBURG, WV 26104

Date Issued

Expiration Date

SEPTEMBER 26, 2007

SEPTEMBER 26, 2008



**WEST VIRGINIA
CONTRACTOR
LICENSING
BOARD**

Authorized Company Signature

Michael A. Carl
Chair, West Virginia Contractor
Licensing Board

This license, or a copy thereof, must be posted in a conspicuous place at every construction site where work is being performed. This license number must appear in all advertisements, on all bid submissions and on all fully executed and binding contracts. This license cannot be assigned or transferred by licensee. Issued under provisions of West Virginia Code, Chapter 21, Article 11.

LETTER OF CREDIT VERIFICATION

Date: SEPTEMBER 26, 2007

West Virginia Purchasing Division
Department of Administration
State Capitol Complex
2019 Washington Street, East
P.O. Box 50130
Charleston, WV 25305-0130

RE: Irrevocable Letter of Credit Number: # 101
State Agency: DEPT OF ADMINISTRATION - PURCHASING DIV
Requisition Number: DEFK8052
Project Description: SAFETY BARRIERS, TRAFFIC (STATIONARY)

We hereby open an Irrevocable Letter of Credit, hereafter known as Letter of Credit Number # 101, effective 9/26/, 2007, in your favor for the account of T. L. SMITH EXCAVATING, for a sum or sums not exceeding \$ 14618,00 (Vendor), payable in part or in full upon demand and receipt from you of a Notice of Forfeiture.

This Letter of Credit will expire on SEPTEMBER 25, 2008. We agree to notify you by certified mail, return receipt requested, at least ninety (90) days prior to the maturity of our intention to either renew or not renew this Letter of Credit. Our failure to notify you will automatically extend the maturity for an additional period of twelve (12) months. Upon notification by you of forfeiture, the entire amount shall be confessed to judgment and be due and payable. At the time of expiration, you may either elect to obtain cash collateral by drawing your on-sight draft on us for an amount not to exceed the unused balance of this Letter or elect to let the Letter of Credit expire.

We will give prompt notice to both T.L. SMITH EXCAVATING (Vendor) and you of any notice received or action filed: [1] alleging the insolvency or bankruptcy of the bank; or [2] alleging any violation of regulatory requirements to do business. In addition, we will give immediate notice to both T.L. SMITH EXCAVATING (Vendor) and you in the event the bank becomes unable to fulfill its obligation under the Letter of Credit for any reason.

This Letter of Credit is non-assignable, non-transferable and is subject to the Uniform Customs and Practice for Documentary Credits (1993 Revisions), International Chamber of Commerce (Publication #500), and to the Uniform Commercial Code.

Sincerely,



CHIEF EXECUTIVE OFFICER
(Title)

WILLIAMSTOWN BANK, INC.
(Lending Institution)

Bank Raised Corporate
Seal Affixed here