



State of West Virginia
 Department of Administration
 Purchasing Division
 2019 Washington Street East
 Post Office Box 50130
 Charleston, WV 25305-0130

Request for Quotation

RFQ NUMBER
DEFK8052

PAGE
1

ADDRESS CORRESPONDENCE TO ATTENTION OF
JOHN ABBOTT
304-558-2544

RFQ COPY

TYPE NAME/ADDRESS HERE

SMH Construction Co., Inc.
 PO Box 1912
 Beckley, WV 25802

DIV ENGINEERING & FACILITIES
 ARMORY BOARD SECTION

1707 COONSKIN DRIVE
 CHARLESTON, WV
 25311-1099 341-6368

DATE PRINTED	TERMS OF SALE	SHIP VIA	FOB	FREIGHT TERMS
09/17/2007				

BID OPENING DATE: 09/26/2007 BID OPENING TIME 01:30PM

LINE	QUANTITY	UOP	CAT NO	ITEM NUMBER	UNIT PRICE	AMOUNT
ADDENDUM #01						
THIS ADDENDUM IS ISSUED TO MODIFY, CLARIFY, ADD TO, AND/OR DELETE THE REQUIREMENTS OF THE ORIGINAL SPECIFICATIONS, AND TO EXTEND THE BID OPENING DATE FROM 9/20/2007 TO 9/26/2007; 1:30 PM.						
ATTACHMENTS: ADDENDUM #01 & PRE-BID SIGN-IN SHEET						
NEW BID OPENING DATE: 9/26/2007; 1:30 PM						
0001	1	LS		550-43		
SAFETY BARRIERS, TRAFFIC (STATIONARY)						
***** THIS IS THE END OF RFQ DEFK8052 *****						TOTAL: \$354,560.00

SEE REVERSE SIDE FOR TERMS AND CONDITIONS

SIGNATURE	TELEPHONE 304-877-6451	DATE 9/26/07
TITLE President	FEN 55-0674033	ADDRESS CHANGES TO BE NOTED ABOVE

WHEN RESPONDING TO RFQ, INSERT NAME AND ADDRESS IN SPACE ABOVE LABELED 'VENDOR'

**GENERAL TERMS & CONDITIONS
REQUEST FOR QUOTATION (RFQ) AND REQUEST FOR PROPOSAL (RFP)**

1. Awards will be made in the best interest of the State of West Virginia.
2. The State may accept or reject in part, or in whole, any bid.
3. All quotations are governed by the *West Virginia Code* and the *Legislative Rules* of the Purchasing Division.
4. Prior to any award, the apparent successful vendor must be properly registered with the Purchasing Division and have paid the required \$125.00 registration fee.
5. All services performed or goods delivered under State Purchase Orders/Contracts are to be continued for the term of the Purchase Order/Contract, contingent upon funds being appropriated by the Legislature or otherwise being made available. In the event funds are not appropriated or otherwise available for these services or goods, this Purchase Order/Contract becomes void and of no effect after June 30.
6. Payment may only be made after the delivery and acceptance of goods or services.
7. Interest may be paid for late payment in accordance with the *West Virginia Code*.
8. Vendor preference will be granted upon written request in accordance with the *West Virginia Code*.
9. The State of West Virginia is exempt from federal and state taxes and will not pay or reimburse such taxes.
10. The Director of Purchasing may cancel any Purchase Order/Contract upon 30 days written notice to the seller.
11. The laws of the State of West Virginia and the *Legislative Rules* of the Purchasing Division shall govern all rights and duties under the Contract, including without limitation the validity of this Purchase Order/Contract.
12. Any reference to automatic renewal is hereby deleted. The Contract may be renewed only upon mutual written agreement of the parties.
13. **BANKRUPTCY:** In the event the vendor/contractor files for bankruptcy protection, this contract is automatically null and void, and is terminated without further order.
14. **HIPAA Business Associate Addendum** - The West Virginia State Government HIPAA Business Associate Addendum (BAA), approved by the Attorney General, and available online at the Purchasing Division's web site (<http://www.state.wv.us/admin/purchase/vrc/hipaa.htm>) is hereby made part of the agreement. Provided that, the Agency meets the definition of a Covered Entity (45 CFR §160.103) and will be disclosing Protected Health Information (45 CFR §160.103) to the vendor.

INSTRUCTIONS TO BIDDERS

1. Use the quotation forms provided by the Purchasing Division.
2. **SPECIFICATIONS:** Items offered must be in compliance with the specifications. Any deviation from the specifications must be clearly indicated by the bidder. Alternates offered by the bidder as **EQUAL** to the specifications must be clearly defined. A bidder offering an alternate should attach complete specifications and literature to the bid. The Purchasing Division may waive minor deviations to specifications.
3. Complete all sections of the quotation form.
4. Unit prices shall prevail in cases of discrepancy.
5. All quotations are considered F.O.B. destination unless alternate shipping terms are clearly identified in the quotation.
6. **BID SUBMISSION:** All quotations must be delivered by the bidder to the office listed below prior to the date and time of the bid opening. Failure of the bidder to deliver the quotations on time will result in bid disqualifications.

SIGNED BID TO:

Department of Administration
Purchasing Division
2019 Washington Street East
Post Office Box 50130
Charleston, WV 25305-0130

DEFK 8052

ADDENDUM:

1. Change / Clarify Line 0001, Paragraph 8.0: Period of Service is 6 months from Notice to Proceed.
2. ADD to Paragraph 4.1.2: The contractor will place 6" of #57 gravel over filter fabric behind wall prior to backfilling in order to allow drainage through weep holes.
3. Change / Clarify Line 0001, Paragraph 10.0: The Bid will be submitted as:

Item	Description	Estimated Quantities	Unit Price	Total Cost
Base Item	Installed Concrete Barrier	2,000'	\$ 176.00	\$ 352,000.00
ADD / QTY	Additional Wall Section Installed	1 LF	\$ 2140.00	\$ 2140.00
ADD / QTY	Additional Post Installed	1 EA	\$ 420.00	\$ 420.00



WEST VIRGINIA ARMY NATIONAL GUARD
CONSTRUCTION & FACILITIES MANAGEMENT OFFICE
1703 Coonskin Drive
Charleston, West Virginia 25311-1085
Phone: 304-561-6539 Fax: 304-561-6458 DSN: 623-6331



SUBJECT: Agenda, Pre-Bid, Coonskin Barriers (DEFK8052)

1. Administrative:

- A. Sign-In Sheet
- C. Funding: Federally funded
- D. User: West Virginia Army National Guard

2. Introduction:

- A. C&FMO Representative: Major Harold Butler (304) 561-6539.
- B. State Purchasing Senior Buyer: John Abbott (304) 558-2544
- C. There is non A&E for this project.
- D. Environmental Program Management Officer: COL Gary Blackhurst, (304) 561-6445

3. General:

- A. Questions must be submitted to Mr. Abbott.
- B. Work Hours/ Access to the Site/Temporary Facilities
 - 1. Normal work-hours are from 7: a.m. 4:00 p.m. Monday to Friday.
 - 2. Contractor must submit a schedule of work to include a request to extend work hours if needed to the Project Manager.
 - 3. Contractor is required to provide to the Project Manager, a listing of personnel, which will be gaining access to the site.
- C. Temporary Facilities:
 - 1. Job trailer, equipment and material storage may be located on site with approval from the WVARNG (Limited Space).
 - 2. Contractor must provide all facilities for contractor use.
- D. Safety
 - 1. All construction activities will be in conjunction with OSHA, Safety and Health Requirements Manual. All construction activities on site will be a hardhat area and marked as such.
 - 2. Access to the site will be restricted and controlled by the Contractor. A visitor's sign-in and hardhats are to be made available for personnel visiting site.

3. Cleanup is required daily. No open dumps of construction materials. Remove surplus soil material, unsuitable topsoil, obstructions, demolished materials, and waste materials including trash and debris, and legally dispose of them off Owner's property.

4. Contractor is responsible for keeping driveways and entrances serving the premises clear and available for the Owner's use.

E. Supervision of Work:

1. Work must be supervised and the WVARNG must be informed of the responsible person on site.

2. Substitution requests must be submitted within 60 days of commencement of work.

4. Summary of Work:

A. Project Description:

1. Review Scope of Work
2. View Site

5. Environmental Comments:

DEFK 8052 PRE-BID SIGN IN SHEET

<u>COMPANY NAME</u>	<u>COMPANY POC</u>	<u>PHONE NUMBER</u>	<u>EMAIL</u>
---------------------	--------------------	---------------------	--------------

Brown's Excavating, Eric Brown, 304-652-2842, eric.browns@verizon.net

Terry L. Smith Excavating, Terry Smith, 304-865-9292, TSLE@suddenlink.net

Alan Stone Co, Claudia Staley, 304-375-6484, alanstone@verizon.net

Upton Construction Co, Joe Tucker, 304-744-4627, UCCl@earth1net.com

WV Paving, Chet Rodabaugh, 304-768-9733, crodabaugh@wvpaving.com

Orders Const, Jared Clonch, 304-722-4237, jaredc@ordersconstruction.com

SMH Const. Co, Sumith Hapuarachy, 304-877-6451, sh1912beck@aol.com

Carr Concrete, Rodney Carr, 800-837-8918, rcarr@carrconcrete.com

WV/ARNG, Harold Butler, 304-561-6539, harold.g.butler@us.army.mil



State of West Virginia
 Department of Administration
 Purchasing Division
 2019 Washington Street East
 Post Office Box 50130
 Charleston, WV 25305-0130

Request for Quotation

RFQ NUMBER
DEFK8052

PAGE
1

ADDRESS CORRESPONDENCE TO ATTENTION OF
JOHN ABBOTT
304-558-2544

RFQ COPY

TYPE NAME/ADDRESS HERE

SMH Construction Co., Inc.
 PO Box 1912
 Beckley, WV 25802

DIV ENGINEERING & FACILITIES
 ARMORY BOARD SECTION

1707 COONSKIN DRIVE
 CHARLESTON, WV
 25311-1099 341-6368

DATE PRINTED	TERMS OF SALE	SHIP VIA	FOB	FREIGHT TERMS
08/22/2007				

BID OPENING DATE: **09/20/2007** BID OPENING TIME **01:30PM**

LINE	QUANTITY	UOP	CAT NO	ITEM NUMBER	UNIT PRICE	AMOUNT
REQUEST FOR QUOTATION						
THE PURCHASING DIVISION IS SOLICITING BIDS FOR THE WEST VIRGINIA ARMY NATIONAL GUARD TO PROVIDE ALL LABOR, EQUIPMENT, AND MATERIALS NECESSARY TO INSTALL CONCRETE BARRIER WALLS.						
ATTACHMENTS: 1. SPECIFICATIONS 2. BID FORM 3. PURCHASING AFFIDAVIT						
MANDATORY ON-SITE PRE-BID: 9/14/2007; 10:00 AM WV ARMY NATIONAL GUARD 1703 COONSKIN DRIVE CHARLESTON, WV 25311						
0001	1	LS		550-43		
SAFETY BARRIERS, TRAFFIC (STATIONARY)						
EXHIBIT 5						
NOTICE TO PROCEED: THIS CONTRACT IS TO BE PERFORMED WITHIN 90 CALENDAR DAYS AFTER THE NOTICE TO PROCEED IS RECEIVED. UNLESS OTHERWISE SPECIFIED, THE FULLY EXECUTED PURCHASE ORDER WILL BE CONSIDERED NOTICE TO PROCEED.						
CANCELLATION: THE DIRECTOR OF PURCHASING RESERVES THE RIGHT TO CANCEL THIS CONTRACT IMMEDIATELY UPON WRITTEN NOTICE TO THE VENDOR IF THE MATERIALS OR WORKMANSHIP SUPPLIED ARE OF AN INFERIOR QUALITY OR DO NOT CONFORM						

SEE REVERSE SIDE FOR TERMS AND CONDITIONS

SIGNATURE	TELEPHONE 304-877-6451	DATE 9/26/07
TITLE President	FEIN 55-0674033	ADDRESS CHANGES TO BE NOTED ABOVE

WHEN RESPONDING TO RFQ, INSERT NAME AND ADDRESS IN SPACE ABOVE LABELED 'VENDOR'



State of West Virginia
 Department of Administration
 Purchasing Division
 2019 Washington Street East
 Post Office Box 50130
 Charleston, WV 25305-0130

Request for Quotation

RFQ NUMBER
DEFK8052

PAGE
2

ADDRESS CORRESPONDENCE TO ATTENTION OF
**JOHN ABBOTT
 304-558-2544**

VENDOR

**RFQ COPY
 TYPE NAME/ADDRESS HERE**

VENDOR

**DIV ENGINEERING & FACILITIES
 ARMORY BOARD SECTION**

**1707 COONSKIN DRIVE
 CHARLESTON, WV
 25311-1099 341-6368**

DATE PRINTED	TERMS OF SALE	SHIP VIA	FOB	FREIGHT TERMS
08/22/2007				

BID OPENING DATE: **09/20/2007** BID OPENING TIME **01:30PM**

LINE	QUANTITY	UOP	CAT NO	ITEM NUMBER	UNIT PRICE	AMOUNT
<p>WITH THE SPECIFICATIONS OF THE BID AND CONTRACT HERE IN.</p> <p>WAGE RATES: THE CONTRACTOR OR SUBCONTRACTOR SHALL PAY THE HIGHER OF THE U.S. DEPARTMENT OF LABOR MINIMUM WAGE RATES AS ESTABLISHED FOR KANAWHA COUNTY, PURSUANT TO WEST VIRGINIA CODE 21-5A, ET, SEQ. (PREVAILING WAGE RATES APPLY TO THIS PROJECT)</p> <p>ARBITRATION: ANY REFERENCES MADE TO ARBITRATION OR INTEREST FOR PAYMENTS DUE (EXCEPT FOR ANY INTEREST REQUIRED BY STATE LAW) CONTAINED IN THIS CONTRACT OR IN ANY AMERICAN INSTITUTE OF ARCHITECTS DOCUMENTS PERTAINING TO THIS CONTRACT ARE HEREBY DELETED.</p> <p>WORKERS' COMPENSATION: VENDOR IS REQUIRED TO PROVIDE A CERTIFICATE FROM WORKERS' COMPENSATION IF SUCCESSFUL.</p> <p>ALL OF THE ITEMS CHECKED BELOW WILL BE A REQUIREMENT OF THIS CONTRACT:</p> <p><input checked="" type="checkbox"/> INSURANCE: SUCCESSFUL VENDOR SHALL FURNISH PROOF OF COMMERCIAL GENERAL LIABILITY INSURANCE PRIOR TO ISSUANCE OF CONTRACT. UNLESS OTHERWISE SPECIFIED IN THE BID DOCUMENTS, THE MINIMUM AMOUNT OF INSURANCE COVERAGE REQUIRED IS \$250,000.</p> <p><input type="checkbox"/> BUILDERS RISK INSURANCE: SUCCESSFUL VENDOR SHALL FURNISH PROOF OF BUILDERS RISK - ALL RISK INSURANCE IN AN AMOUNT EQUAL TO 100% OF THE AMOUNT OF THE CONTRACT.</p> <p><input checked="" type="checkbox"/> BONDS: FIVE PERCENT (5%) OF THE TOTAL AMOUNT OF THE BID PAYABLE TO THE STATE OF WEST VIRGINIA, SHALL BE SUBMITTED WITH EACH BID AS A BID BOND. THE SUCCESSFUL BIDDER SHALL ALSO FURNISH A PERFORMANCE BOND AND LABOR/MATERIAL BOND FOR 100% OF THE AMOUNT OF THE CONTRACT.</p>						

SEE REVERSE SIDE FOR TERMS AND CONDITIONS

SIGNATURE	TELEPHONE	DATE
TITLE	FEIN	ADDRESS CHANGES TO BE NOTED ABOVE

WHEN RESPONDING TO RFQ, INSERT NAME AND ADDRESS IN SPACE ABOVE LABELED 'VENDOR'



State of West Virginia
 Department of Administration
 Purchasing Division
 2019 Washington Street East
 Post Office Box 50130
 Charleston, WV 25305-0130

Request for Quotation

RFQ NUMBER
DEFK8052

PAGE
3

ADDRESS CORRESPONDENCE TO ATTENTION OF
**JOHN ABBOTT
 304-558-2544**

VENDOR

**RFQ COPY
 TYPE NAME/ADDRESS HERE**

SHIP TO

**DIV ENGINEERING & FACILITIES
 ARMORY BOARD SECTION
 1707 COONSKIN DRIVE
 CHARLESTON, WV
 25311-1099 341-6368**

DATE PRINTED	TERMS OF SALE	SHIP VIA	F.O.B.	FREIGHT TERMS
08/22/2007				

BID OPENING DATE: **09/20/2007** BID OPENING TIME **01:30PM**

LINE	QUANTITY	UOP	CAT NO	ITEM NUMBER	UNIT PRICE	AMOUNT
<p>BONDS MAY BE PROVIDED IN THE FORM OF A CERTIFIED CHECK, IRREVOCABLE LETTER OF CREDIT, OR BOND FURNISHED BY A SOLVENT SURETY COMPANY AUTHORIZED TO DO BUSINESS IN THE STATE OF WEST VIRGINIA. A LETTER OF CREDIT SUBMITTED IN LIEU OF A PERFORMANCE AND LABOR & MATERIAL BOND WILL ONLY BE ALLOWED FOR PROJECTS UNDER \$100,000. PERSONAL OR BUSINESS CHECKS ARE NOT ACCEPCTABLE IN LIEU OF THE 5% BID BOND, PERFORMANCE BOND, OR LABOR AND MATERIAL BOND.</p> <p>() MAINTENANCE BOND: A TWO (2) YEAR MAINTENANCE BOND COVERING THE ROOFING SYSTEM WILL BE A REQUIREMENT OF THE SUCCESSFUL VENDOR.</p> <p>REV. 11/00</p> <p>EXHIBIT 7</p> <p>DOMESTIC ALUMINUM, GLASS & STEEL IN PUBLIC WORKS PROJECTS</p> <p>IN ACCORDANCE WITH WEST VIRGINIA CODE 5-19-1 ET., SEQ., EVERY CONTRACT FOR CONSTRUCTION, RECONSTRUCTION, ALTERATION, REPAIR, IMPROVEMENT OR MAINTENANCE OF PUBLIC WORKS, WHERE THE COST IS MORE THAN \$50,000 AND, IN THE CASE OF STEEL ONLY, WHERE THE COST OF STEEL IS MORE THAN \$50,000 OR WHERE MORE THAN 10,000 POUNDS OF STEEL ARE REQUIRED, THE STATE WILL ACCEPT ONLY ALUMINUM GLASS, OR STEEL PRODUCTS PRODUCED IN THE UNITED STATES IN ADDITION, ITEMS OF MACHINERY OR EQUIPMENT PURCHASED FOR USE AT THE SITE OF PUBLIC WORKS SHALL BE MADE OF DOMESTIC ALUMINUM, GLASS OR STEEL, UNLESS THE COST OF THE PRODUCT IS LESS THAN \$50,000 OR LESS THAN 10,000 POUNDS OF STEEL ARE USED IN PUBLIC WORKS PROJECTS.</p>						

SEE REVERSE SIDE FOR TERMS AND CONDITIONS

SIGNATURE	TELEPHONE	DATE
TITLE	FEIN	ADDRESS CHANGES TO BE NOTED ABOVE

WHEN RESPONDING TO RFQ, INSERT NAME AND ADDRESS IN SPACE ABOVE LABELED 'VENDOR'



State of West Virginia
 Department of Administration
 Purchasing Division
 2019 Washington Street East
 Post Office Box 50130
 Charleston, WV 25305-0130

Request for Quotation

RFQ NUMBER
DEFK8052

PAGE
4

ADDRESS CORRESPONDENCE TO ATTENTION OF
JOHN ABBOTT
304-558-2544

RFQ COPY
 TYPE NAME/ADDRESS HERE

DIV ENGINEERING & FACILITIES
 ARMORY BOARD SECTION
 1707 COONSKIN DRIVE
 CHARLESTON, WV
 25311-1099 341-6368

DATE PRINTED	TERMS OF SALE	SHIP VIA	FOB	FREIGHT TERMS
08/22/2007				

BID OPENING DATE: **09/20/2007** BID OPENING TIME **01:30PM**

LINE	QUANTITY	UOP	CAT NO	ITEM NUMBER	UNIT PRICE	AMOUNT
<p>FOREIGN MADE ALUMINUM, GLASS OR STEEL PRODUCTS MAY BE ACCEPTED ONLY IF THE COST OF DOMESTIC PRODUCTS IS FOUND TO BE UNREASONABLE. SUCH COST IS UNREASONABLE IF IT IS 20% OR MORE HIGHER THAN THE BID PRICE FOR FOREIGN MADE PRODUCTS. IF THE DOMESTIC ALUMINUM, GLASS OR STEEL PRODUCTS TO BE SUPPLIED OR PRODUCED IN A "SUBSTANTIAL LABOR SURPLUS AREA", AS DEFINED BY THE UNITED STATES DEPARTMENT OF LABOR, FOREIGN PRODUCTS MAY BE SUPPLIED ONLY IF DOMESTIC PRODUCTS ARE 30% OR MORE HIGHER IN PRICE THAN THE FOREIGN MADE PRODUCTS.</p> <p>IF, PRIOR TO THE AWARD OF A CONTRACT UNDER THE ABOVE PROVISIONS, THE SPENDING OFFICER OF THE SPENDING UNIT DETERMINES THAT THERE EXISTS A BID FOR LIKE FOREIGN ALUMINUM, GLASS OR STEEL THAT IS REASONABLE AND LOWER THAN THE LOWEST BID DOMESTIC PRODUCTS, THE SPENDING OFFICE MAY REQUEST, IN WRITING, A REEVALUATION AND REDUCTION IN THE LOWEST BID FOR SUCH DOMESTIC PRODUCTS ALL VENDORS MUST INDICATE IN THEIR BID IF THEY ARE SUPPLYING FOREIGN ALUMINUM, GLASS OR STEEL.</p> <p>REV. 3/88</p> <p>EXHIBIT 9</p> <p>NOTICE FOR ISSUANCE & ACKNOWLEDGEMENT OF CONSTRUCTION PROJECT ADDENDA</p> <p>THE ARCHITECT/ENGINEER AND/OR AGENCY SHALL BE REQUIRED TO ABIDE BY THE FOLLOWING SCHEDULE IN ISSUING CONSTRUCTION PROJECT ADDENDA FOR STATE AGENCIES:</p> <p>(1) THE ARCHITECT/ENGINEER SHALL PREPARE THE ADDENDUM AND A LIST OF ALL PARTIES THAT HAVE PROCURED DRAWINGS AND SPECIFICATIONS FOR THE PROJECT. THE ADDENDUM</p>						

SEE REVERSE SIDE FOR TERMS AND CONDITIONS

SIGNATURE	TELEPHONE	DATE
TITLE	FEIN	ADDRESS CHANGES TO BE NOTED ABOVE

WHEN RESPONDING TO RFQ, INSERT NAME AND ADDRESS IN SPACE ABOVE LABELED 'VENDOR'



State of West Virginia
 Department of Administration
 Purchasing Division
 2019 Washington Street East
 Post Office Box 50130
 Charleston, WV 25305-0130

Request for Quotation

RFQ NUMBER
DEFK8052

PAGE
5

ADDRESS CORRESPONDENCE TO ATTENTION OF
JOHN ABBOTT
304-558-2544

RFQ COPY
TYPE NAME/ADDRESS HERE

VENDOR

SHIP TO

DIV ENGINEERING & FACILITIES
ARMORY BOARD SECTION

1707 COONSKIN DRIVE
CHARLESTON, WV
25311-1099 341-6368

DATE PRINTED	TERMS OF SALE	SHIP VIA	FOB	FREIGHT TERMS
08/22/2007				

BID OPENING DATE: **09/20/2007** BID OPENING TIME **01:30PM**

LINE	QUANTITY	UOP	CAT NO	ITEM NUMBER	UNIT PRICE	AMOUNT
<p>AND LIST SHALL BE FORWARDED TO THE BUYER IN THE STATE PURCHASING DIVISION. THE ARCHITECT/ENGINEER SHALL ALSO SEND A COPY OF THE ADDENDUM TO THE STATE AGENCY FOR WHICH THE CONTRACT IS ISSUED.</p> <p>(2) THE BUYER SHALL SEND THE ADDENDUM TO ALL INTERESTED PARTIES AND, IF NECESSARY, EXTEND THE BID OPENING DATE. ANY ADDENDUM SHOULD BE RECEIVED BY THE BUYER WITHIN FOURTEEN (14) DAYS PRIOR TO THE BID OPENING DATE.</p> <p>(3) ALL ADDENDA SHOULD BE FORMALLY ACKNOWLEDGED BY ALL BIDDERS AND SUBMITTED TO THE STATE PURCHASING DIVISION. THE SAME RULES AND REGULATIONS THAT APPLY TO THE ORIGINAL BIDDING DOCUMENT SHALL ALSO APPLY TO AN ADDENDUM DOCUMENT. THE ONLY EXCEPTION MAY BE FOR AN ADDENDUM THAT IS ISSUED FOR THE SOLE PURPOSE OF CHANGING A BID OPENING TIME AND/OR DATE.</p> <p>REV. 11/96</p> <p>EXHIBIT 10</p> <p>ADDENDUM ACKNOWLEDGEMENT</p> <p>I HEREBY ACKNOWLEDGE RECEIPT OF THE FOLLOWING CHECKED ADDENDUM(S) AND HAVE MADE THE NECESSARY REVISIONS TO MY PROPOSAL, PLANS AND/OR SPECIFICATION, ETC.</p> <p>ADDENDUM NOS.:</p> <p>NO. 1 ✓</p> <p>NO. 2 </p>						

SEE REVERSE SIDE FOR TERMS AND CONDITIONS

SIGNATURE _____ TELEPHONE _____ DATE _____

TITLE _____ FEIN _____ ADDRESS CHANGES TO BE NOTED ABOVE

WHEN RESPONDING TO RFQ, INSERT NAME AND ADDRESS IN SPACE ABOVE LABELED 'VENDOR'



State of West Virginia
 Department of Administration
 Purchasing Division
 2019 Washington Street East
 Post Office Box 50130
 Charleston, WV 25305-0130

Request for Quotation

RFQ NUMBER
DEFK8052

PAGE
6

ADDRESS CORRESPONDENCE TO ATTENTION OF
**JOHN ABBOTT
 304-558-2544**

VENDOR

RFQ COPY
 TYPE NAME/ADDRESS HERE

SHIP TO

**DIV ENGINEERING & FACILITIES
 ARMORY BOARD SECTION
 1707 COONSKIN DRIVE
 CHARLESTON, WV
 25311-1099 341-6368**

DATE PRINTED	TERMS OF SALE	SHIP VIA	FOB	FREIGHT TERMS
08/22/2007				

BID OPENING DATE: **09/20/2007** BID OPENING TIME **01:30PM**

LINE	QUANTITY	UOP	CAT NO	ITEM NUMBER	UNIT PRICE	AMOUNT
NO. 3					
NO. 4					
NO. 5					
<p>I UNDERSTAND THAT FAILURE TO CONFIRM THE RECEIPT OF THE ADDENDUM(S) MAY BE CAUSE FOR REJECTION OF THE BIDS.</p> <p>..... <i>SMH Construction Co., Inc.</i>.....SIGNATURE</p> <p>..... <i>SMH Construction Co., Inc.</i>.....COMPANY</p> <p>..... <i>09-26-07</i>.....DATE</p> <p>REV. 11/96</p> <p>CONTRACTORS LICENSE</p> <p>WEST VIRGINIA STATE CODE 21-11-2 REQUIRES THAT ALL PERSONS DESIRING TO PERFORM CONTRACTING WORK IN THIS STATE MUST BE LICENSED. THE WEST VIRGINIA CONTRACTORS LICENSING BOARD IS EMPOWERED TO ISSUE THE CONTRACTORS LICENSE. APPLICATIONS FOR A CONTRACTORS LICENSE MAY BE MADE BY CONTACTING THE WEST VIRGINIA DIVISION OF LABOR CAPITOL COMPLEX, BUILDING 3, ROOM 319, CHARLESTON, WV 25305. TELEPHONE: (304) 558-7890.</p> <p>WEST VIRGINIA STATE CODE 21-11-11 REQUIRES ANY PROSPECTIVE BIDDER TO INCLUDE THE CONTRACTORS LICENSE NUMBER ON THEIR BID.</p> <p>BIDDER TO COMPLETE:</p>						

SEE REVERSE SIDE FOR TERMS AND CONDITIONS

SIGNATURE	TELEPHONE	DATE
TITLE	FEIN	ADDRESS CHANGES TO BE NOTED ABOVE

WHEN RESPONDING TO RFQ, INSERT NAME AND ADDRESS IN SPACE ABOVE LABELED 'VENDOR'



State of West Virginia
 Department of Administration
 Purchasing Division
 2019 Washington Street East
 Post Office Box 50130
 Charleston, WV 25305-0130

Request for Quotation

RFQ NUMBER
DEFK8052

PAGE
7

ADDRESS CORRESPONDENCE TO ATTENTION OF
JOHN ABBOTT
304-558-2544

VENDOR

RFQ COPY
 TYPE NAME/ADDRESS HERE

SHIP TO

DIV ENGINEERING & FACILITIES
ARMORY BOARD SECTION

1707 COONSKIN DRIVE
CHARLESTON, WV
25311-1099 341-6368

DATE PRINTED	TERMS OF SALE	SHIP VIA	FOB	FREIGHT TERMS
08/22/2007				

BID OPENING DATE: **09/20/2007** BID OPENING TIME **01:30PM**

LINE	QUANTITY	UOP	CAT NO	ITEM NUMBER	UNIT PRICE	AMOUNT
<p>CONTRACTORS NAME: <i>SMH Construction Co., Inc.</i></p> <p>CONTRACTORS LICENSE NO.: <i>WV000572</i></p> <p>THE SUCCESSFUL BIDDER WILL BE REQUIRED TO FURNISH A COPY OF THEIR CONTRACTORS LICENSE PRIOR TO ISSUANCE OF A PURCHASE ORDER/CONTRACT</p> <p style="text-align: center;">APPLICABLE LAW</p> <p>THE WEST VIRGINIA STATE CODE, PURCHASING DIVISION RULE AND REGULATIONS, AND THE INFORMATION PROVIDED IN THE "REQUEST FOR QUOTATION" ISSUED BY THE PURCHASING DIVISION IS THE SOLE AUTHORITY GOVERNING THIS PROCUREMENT.</p> <p>ANY INFORMATION PROVIDED IN SPECIFICATION MANUALS, OR ANY OTHER SOURCE, VERBAL OR WRITTEN, WHICH CONTRADICTS OR ALTERS THE INFORMATION PROVIDED FROM THE SOURCES AS DESCRIBED IN THE ABOVE PARAGRAPH IS VOID AND OF NO EFFECT.</p> <p>BANKRUPTCY: IN THE EVENT THE VENDOR/CONTRACTOR FILES FOR BANKRUPTCY PROTECTION, THIS CONTRACT IS AUTOMATICALLY NULL AND VOID, AND IS TERMINATED WITHOUT FURTHER ORDER.</p> <p>REV. 1/2005</p> <p style="text-align: center;">NOTICE</p> <p>A SIGNED BID MUST BE SUBMITTED TO:</p> <p style="text-align: center;">DEPARTMENT OF ADMINISTRATION</p>						

SEE REVERSE SIDE FOR TERMS AND CONDITIONS

SIGNATURE	TELEPHONE	DATE
TITLE	FEIN	ADDRESS CHANGES TO BE NOTED ABOVE

WHEN RESPONDING TO RFQ, INSERT NAME AND ADDRESS IN SPACE ABOVE LABELED 'VENDOR'



State of West Virginia
 Department of Administration
 Purchasing Division
 2019 Washington Street East
 Post Office Box 50130
 Charleston, WV 25305-0130

Request for Quotation

RFQ NUMBER
DEFK8052

PAGE
8

ADDRESS CORRESPONDENCE TO ATTENTION OF
JOHN ABBOTT
304-558-2544

VENDOR

RFQ COPY
 TYPE NAME/ADDRESS HERE

BUYER

DIV ENGINEERING & FACILITIES
ARMORY BOARD SECTION

1707 COONSKIN DRIVE
CHARLESTON, WV
25311-1099 341-6368

DATE PRINTED:	TERMS OF SALE:	SHIP VIA:	FOB:	FREIGHT TERMS:
08/22/2007				

BID OPENING DATE: **09/20/2007** BID OPENING TIME **01:30PM**

LINE	QUANTITY	UOP	CAT NO	ITEM NUMBER	UNIT PRICE	AMOUNT
<p>PURCHASING DIVISION BUILDING 15 2019 WASHINGTON STREET, EAST CHARLESTON, WV 25305-0130</p> <p>THE BID SHOULD CONTAIN THIS INFORMATION ON THE FACE OF THE ENVELOPE OR THE BID MAY NOT BE CONSIDERED:</p> <p>SEALED BID</p> <p>BUYER: JOHN ABBOTT</p> <p>REQ. NO.: DEFK8052</p> <p>BID OPENING DATE: 9/20/2007</p> <p>BID OPENING TIME: 1:30 PM</p> <p>PLEASE PROVIDE A FAX NUMBER IN CASE IT IS NECESSARY TO CONTACT YOU REGARDING YOUR BID: 304-877-5789</p> <p>PLEASE PRINT OR TYPE NAME OF PERSON TO CONTACT CONCERNING THIS QUOTE: Sumith Hapvarechy</p>						

SEE REVERSE SIDE FOR TERMS AND CONDITIONS

SIGNATURE	TELEPHONE	DATE
TITLE	FEIN	ADDRESS CHANGES TO BE NOTED ABOVE

WHEN RESPONDING TO RFQ, INSERT NAME AND ADDRESS IN SPACE ABOVE LABELED 'VENDOR'



State of West Virginia
 Department of Administration
 Purchasing Division
 2019 Washington Street East
 Post Office Box 50130
 Charleston, WV 25305-0130

Request for Quotation

RFQ NUMBER
DEFK8052

PAGE
9

ADDRESS CORRESPONDENCE TO ATTENTION OF
JOHN ABBOTT
304-558-2544

RFQ COPY
TYPE NAME/ADDRESS HERE

SIGNATURE

SIGNATURE

DIV ENGINEERING & FACILITIES
ARMORY BOARD SECTION

1707 COONSKIN DRIVE
CHARLESTON, WV
25311-1099 341-6368

DATE PRINTED	TERMS OF SALE	SHIP VIA	FOB	FREIGHT TERMS
08/22/2007				

BID OPENING DATE: **09/20/2007** BID OPENING TIME **01:30PM**

LINE	QUANTITY	UOP	CAT NO	ITEM NUMBER	UNIT PRICE	AMOUNT
***** THIS IS THE END OF RFQ DEFK8052 ***** TOTAL:						<u>\$354,560.00</u>

SEE REVERSE SIDE FOR TERMS AND CONDITIONS

SIGNATURE		TELEPHONE	DATE
TITLE	FEIN	ADDRESS CHANGES TO BE NOTED ABOVE	

WHEN RESPONDING TO RFQ, INSERT NAME AND ADDRESS IN SPACE ABOVE LABELED 'VENDOR'

**JOINT FORCES HEADQUARTERS BARRIER INSTALLATION
WEST VIRGINIA ARMY NATIONAL GUARD (WVARNG)
1703 COONSKIN DRIVE
CHARLESTON, WV 25311**

1.0 INTRODUCTION

JFHQ is made-up of several buildings and facilities on both sides of Coonskin Drive. The WVARNG intends to reinforce the existing natural or man-made obstacles using a system of concrete and post and cable barriers to provide for a more secure environment

2.0 LOCATION

JFHQ is located on Coonskin Drive prior to entry to Coonskin Park. Coonskin Drive and the buildings are relatively level through the site though the facilities are generally located several feet above the elevation of the road.

3.0 SCOPE / OBJECTIVE

It is the desire of the WVARNG to install a functional barrier system that can be easily maintained, won't detract from the appearance of facilities, and may be modified or removed at a later date and will use the slope between our facilities and Coonskin Drive and incorporates previously installed barriers and gates.

4.0 REQUIREMENTS AND SPECIFICATIONS.

4.1 Project Specific:

4.1.1 Site: The attached schematic is an approximation provided for general information (See Attachment 3). The awarded contractor will be responsible for field measuring all distances and surveyor support as needed. These specifications include reference to Carr Concrete Protector Guard Wall CCC-PGW-100 or like item (See Attachment 1). If used as part of a bid, a submittal for like items must be included that lists materials, dimensions, weight, method of handling, finish, means of manufacture, and manufacture lead-time. Barriers are intended to be parallel or perpendicular to Coonskin Drive whenever possible and generally aligned to one-another. Installation may require modification to specified length of individual barriers.

4.1.2 Concrete Barrier System: The barrier system will be of modular concrete design consistent with Carr Concrete Protector Guard Wall CCC-PGW-100. Installation will be consistent with attached design and will generally be imbedded in slope. All sections will be placed on excavated and compacted soil with a 4" topping of compacted gravel. The excavation will be accomplished so that cut will equal the amount of material needed to fill the up-slope side of the section level to the top (No material is to be removed from the site without consent from the WVARNG) (See Attachment 2).

4.1.3 Runs: A 4' gap, outside edge to outside edge, will be left between stairwell and wall, gatepost and wall, and breaks in wall runs. Continuous lengths of wall run should be no greater than 70'. Barrier segments will begin and end in a post.

4.1.4 Seeding: The contractor will seed, fertilize, and mulch all disturbed areas and will submit fertilizer and seed content for approval prior to application.

4.1.5 Erosion: The contractor is responsible for developing and submitting runoff and erosion control measures or permits as necessary.

4.1.6 Funding: This project is based upon availability of funding; sum or all of the segments in Attachment 3 may represent the final scope of this project.

4.2 General

4.2.1. Construction will follow all national and state building codes.

4.2.2. The developed and approved design will be utilized for all construction.

4.2.3. All construction will result in a complete and functional system unless noted otherwise.

4.2.4. All construction activities will be in conjunction with OSHA, Safety and Health Requirements Manual (US Army Corps of Engineers) and FFA. As noted, the Army safety and health standards mirror OSHA. All construction activities on site will be a hardhat area and marked as such.

4.2.5. Access to the site will be restricted and controlled by the Contractor. A visitor's sign-in and hardhats are to be made available for personnel visiting site.

4.2.6. Fueling and open flame: Any operation will be maintained in accordance with OSHA and WV Fire Marshall Standards to included secondary containment, fire extinguishers, and spill control.

4.2.7. Cleanup is required daily. No open dumps of construction materials. Remove surplus soil material, unsuitable topsoil, obstructions, demolished materials, and waste materials including trash and debris, and legally dispose of them off Owner's property. Consideration will be given to relocating crushed pavement, gravel and clean soil on the property with the owner's permission.

4.2.8 Contractor is responsible for keeping driveways and entrances serving the premises clear and available for the Owner's use.

4.2.9 Repair to damaged structures, contents, and surrounding grounds will be the contractor's responsibility.

4.2.10 The contractor shall not use WVARNG facilities without prior approval; this includes dumpsters, restrooms, phones, or utilities.

4.2.11 Contractor shall coordinate storage of materials and equipment park locations with the WVARNG.

4.2.12 WVARNG sites are secure. Coordination must be made for all personnel, equipment, materials, deliveries, and sub-contractors. ID such as a driver's license is required. All personnel and vehicles are subject to search.

4.2.13 All work will be supervised. The WVARNG will be provided the name of the on-site person in charge with a means of immediate contact.

4.2.14 The contractor is responsible for paying current and applicable prevailing wage rates and providing certified payrolls as directed.

4.2.15 In accordance with FAR 11.504(b) and DFARS 211.504(b), liquidated damages will be assessed for each calendar day required to complete the construction work on this project past the scheduled completion date. The contractor has complete control of the pace of work. Liquidated damages shall be assessed at a rate of \$1,345.13 as follows:

ITEM	Daily Costs	Notes
Project Management		
Project Manager	\$ 412.39	Based upon 8 hours per day at \$51.55/hr
Transportation Costs	\$ 131.25	Based upon 350 miles round trip at \$.375/mile
Subtotal cost per Day	\$ 543.64	
Procurement		
Contracting Officer	\$ 412.39	Based upon 8 hours per day at \$51.55/hr
Contract Administrator	\$ 340.35	Based upon 8 hours per day at \$42.54/hr
Transportation Costs	\$ 48.75	Based upon 130 miles round trip at \$.375/mile
Subtotal cost per Day	\$ 801.49	
Total for Liquidated Damages	\$ 1,345.13	

5. DATES

Mandatory Prebid Conference

09/14/2007

6.0 MEETINGS AND REVIEWS

6.1 A mandatory prebid conference shall be conducted on the date specified above at the Drill Hall, WV Army National Guard Complex, 1703 Coonskin Drive, Charleston, WV. The Drill Hall is the first brick building on the left after going by the Air National Guard. Potential bidders will park in Visitor's Parking and will enter the glass doors on the end of the building and under the overhang. All interested bidders are required to be present at this meeting. Failure to attend the mandatory prebid conference shall automatically result in disqualification. No one person can represent more than one vendor.

6.2 Prior to initiation of work, the contractor shall meet with the WVARNG. The Contractor will provide weekly updates to Post Engineering during contract period.

7.0 SPECIAL CONSIDERATIONS

The contractors shall coordinate all work with the WVARNG. This will include scheduling work to avoid conflicts with operations. Prior arrangements must be made to work outside work hours. Normal work hours for this location are 7:30 am to 4:00 pm Monday – Friday.

It is the designated contractor's responsibility to conduct all activities in a manner that ensures the safety of crewmembers and avoids damage to vehicles and property of the WVARNG.

8.0 PERIOD OF SERVICE

Construction contractor will have 16 weeks to complete construction upon receipt of Notice to Proceed.

9.0 FINAL INSPECTION AND ACCEPTANCE: Completion of work upon agreement by contractor and WVARNG.

10.0 Bids

Bid Form:

Item	Description	Estimated Quantities	Unit Price Per Linear Foot	Total Cost
Base Item	Installed Concrete Barrier	2,000'	\$	\$

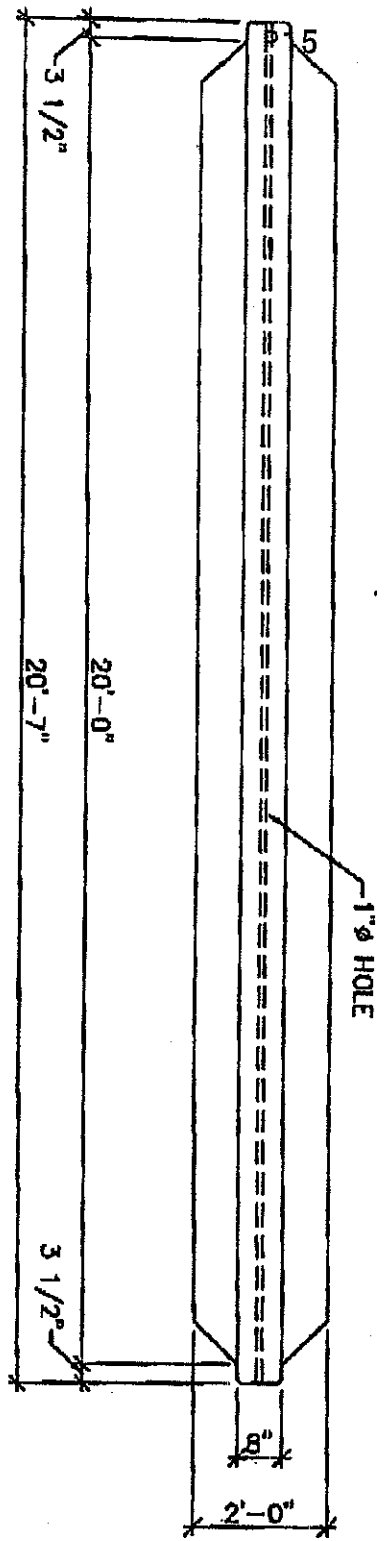

PLAN VIEW

ATTACHMENT 2

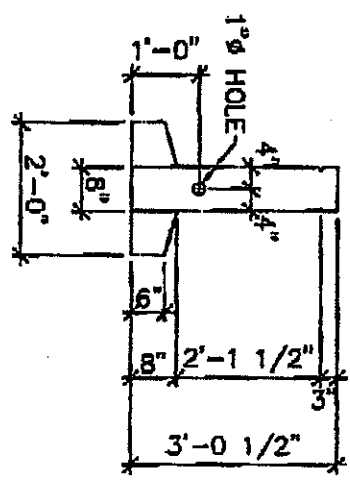

SECTION VIEW

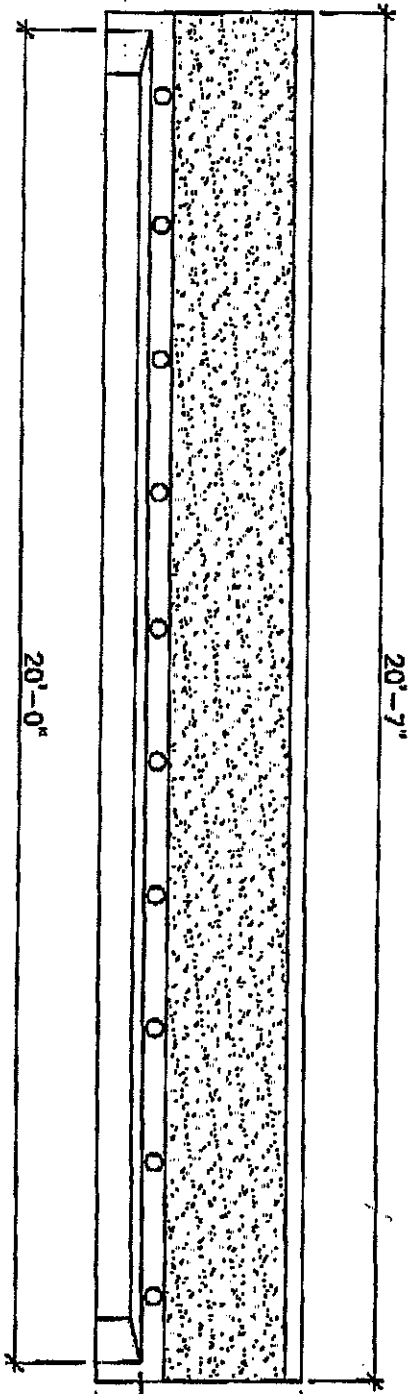

ELEVATION VIEW



CARR CONCRETE
 CARR CONCRETE CORPORATION
 P.O. BOX 265
 WEAVER, WV 26184-0265

PHONE: 800-837-8918
 FAX: 304-464-4013

PROJECT	PROTECTOR GUARD WALL CCC-PGW-100	
LOCATION	WYARNG	
CHARACTER	CHARLESTON, WV	
DRAWN BY	J. NORMAN	DATE
DATE	6-13-07	
NO.	1	
REV.	2	
REV.	3	
REV.	1	
REV.	1	
REV.	1	

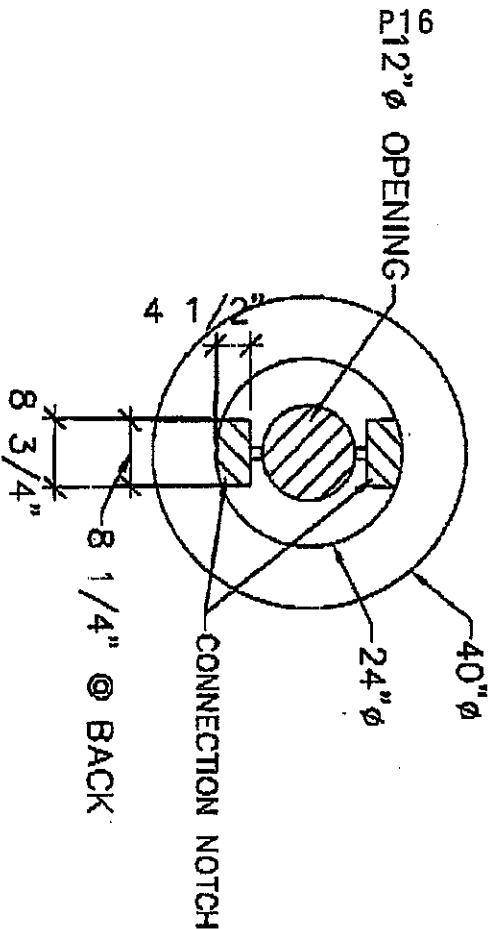

PLAN VIEW

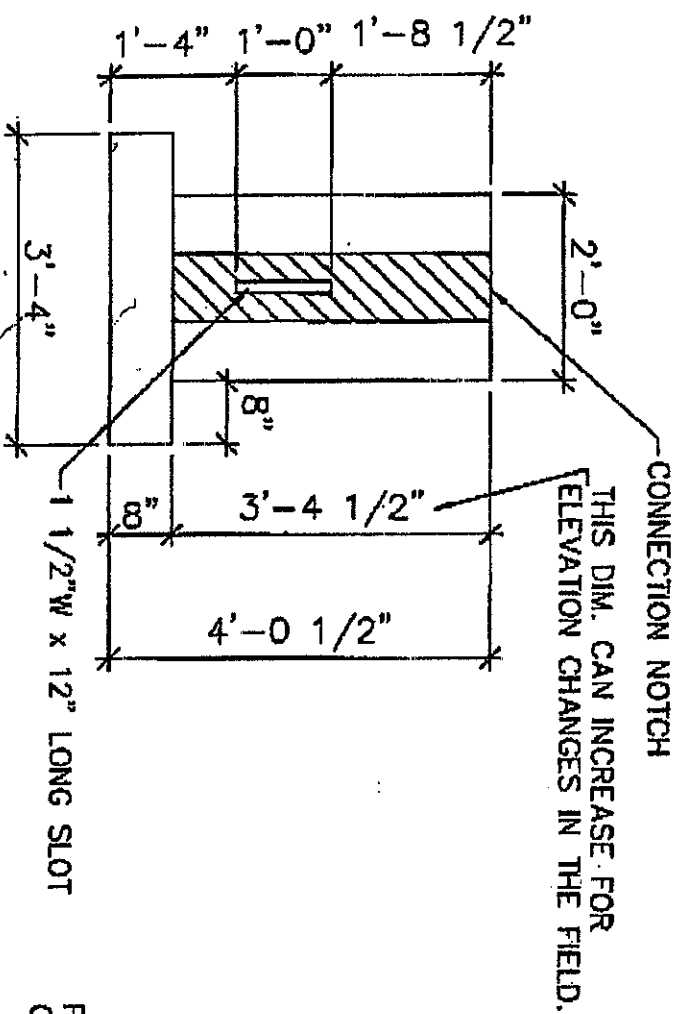

ELEVATION VIEW

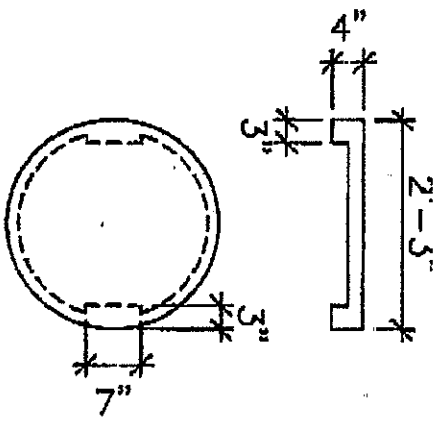

NOTE: WHERE WALL ELEVATION CHANGES, THERE WILL NEED TO BE SOME FIELD GROUTING TO CLOSE CONNECTION NOTCH WHERE CAP DOES NOT COVER UP.

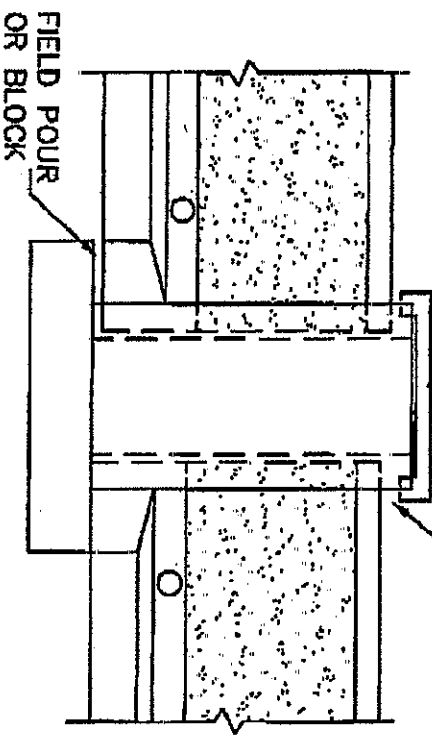

CARR CONCRETE
 CARR CONCRETE CORPORATION
 P.O. BOX 285
 WAVERLY, WV, 26184-0285

PHONE: 800-837-8918
 FAX: 304-464-4013

PROJECTOR	GUARD WALL CCC-PGW-100
DESIGNED BY	WVARRNG
CHARLESTON, WV	
DATE	8-13-07
REV	DATE
1	
2	
3	

P17

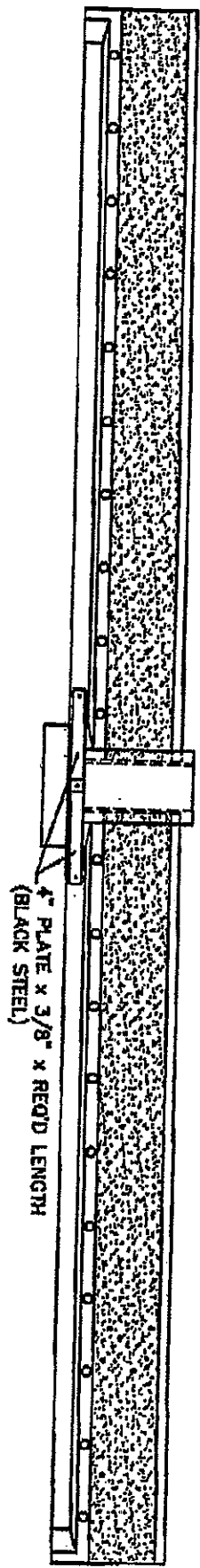

ELEVATION VIEW

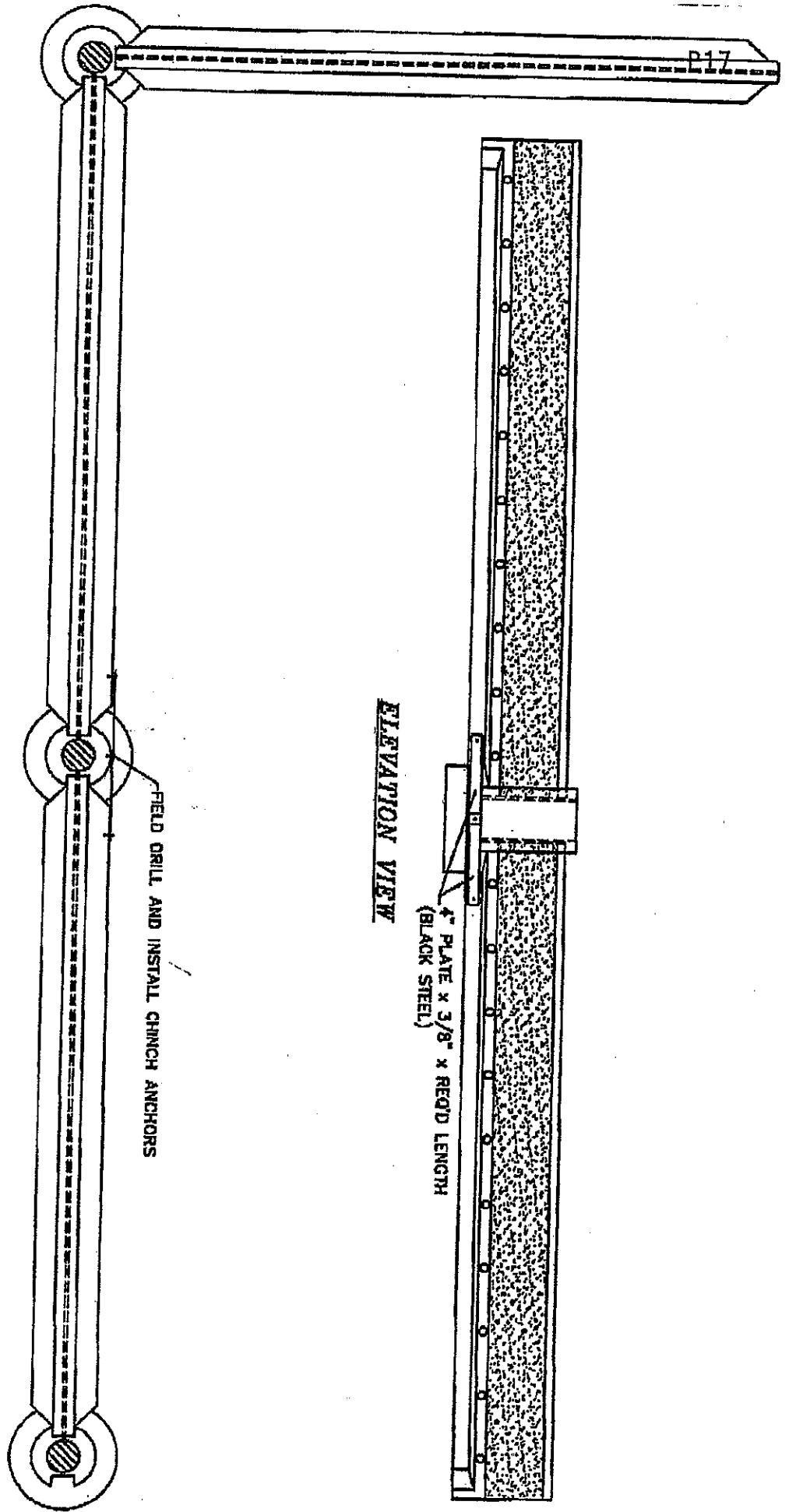

PLAN VIEW



CARR CONCRETE
 CARR CONCRETE CORPORATION
 P.O. BOX 265
 WAVERLY, WV 26184-0265

PHONE: 800-837-8918
 FAX: 304-484-4013

PROJECTOR GUARD WALL CCC-PGW-100		DRAWN BY: J MORGAN	DATE: 6-15-07
WVARNG			
CHARLESTON, WV			
REV	DATE		
3			
3			
3			
3			
3			

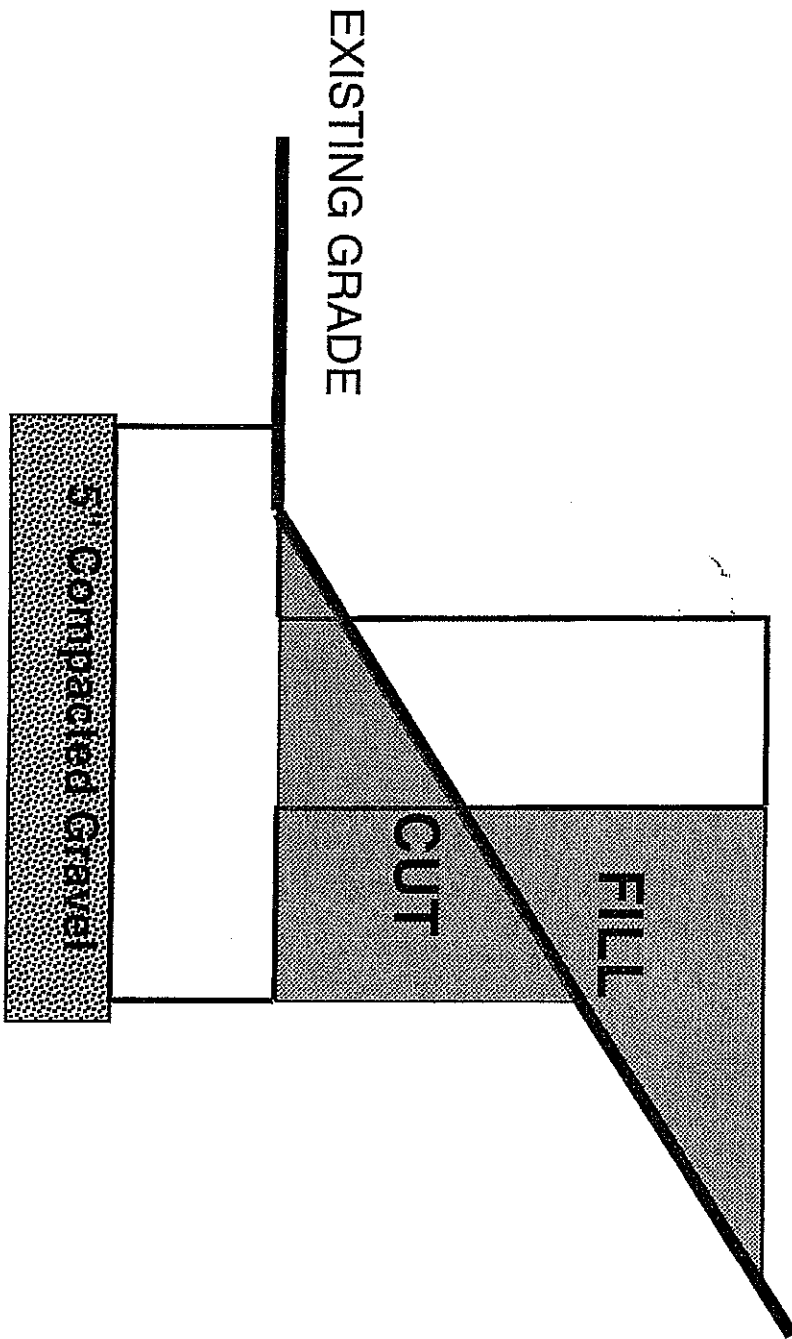

WV ARMY NATIONAL GUARD BARRIER PLAN
 COONSKIN DRIVE, CHARLESTON, WV 25311

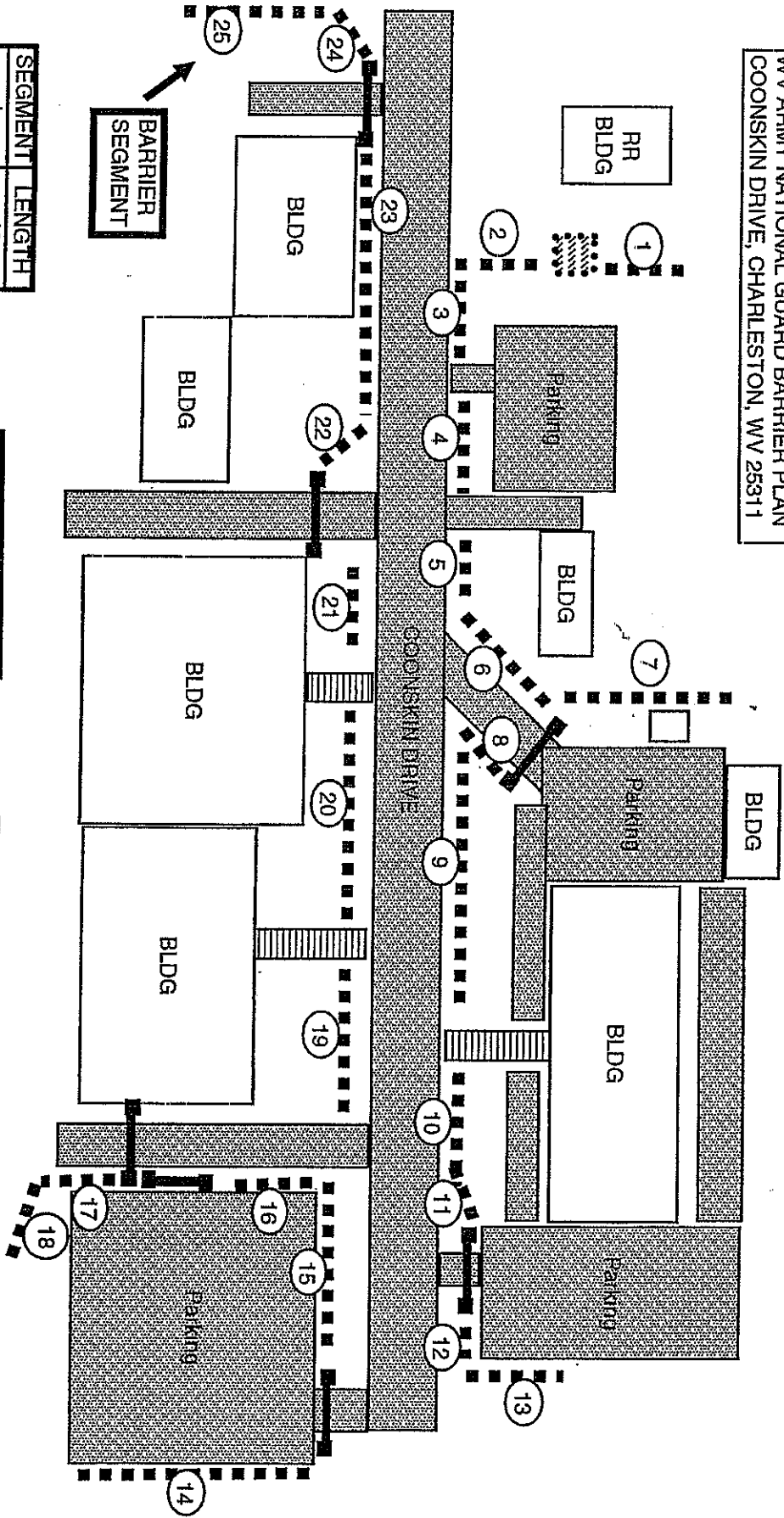

SEGMENT	LENGTH
1	40
2	20
3	15
4	20
5	100
6	110
7	125
8	80
9	320

SEGMENT	LENGTH
10	200
11	35
12	26
13	100
14	40
15	170
16	40
17	20

SEGMENT	LENGTH
18	75
19	140
20	160
21	110
22	40
23	200
24	50
25	100

TOTAL 2336

STATE OF WEST VIRGINIA
Purchasing Division

PURCHASING AFFIDAVIT

West Virginia Code §5A-3-10a states: No contract or renewal of any contract may be awarded by the state or any of its political subdivisions to any vendor or prospective vendor when the vendor or prospective vendor or a related party to the vendor or prospective vendor is a debtor and the debt owned is an amount greater than one thousand dollars in the aggregate

DEFINITIONS:

"Debt" means any assessment, premium, penalty, fine, tax or other amount of money owed to the state or any of its political subdivisions because of a judgment, fine, permit violation, license assessment, defaulted workers' compensation premium, penalty or other assessment presently delinquent or due and required to be paid to the state or any of its political subdivisions, including any interest or additional penalties accrued thereon.

"Debtor" means any individual, corporation, partnership, association, limited liability company or any other form or business association owing a debt to the state or any of its political subdivisions. "Political subdivision" means any county commission; municipality; county board of education; any instrumentality established by a county or municipality; any separate corporation or instrumentality established by one or more counties or municipalities, as permitted by law; or any public body charged by law with the performance of a government function or whose jurisdiction is coextensive with one or more counties or municipalities. "Related party" means a party, whether an individual, corporation, partnership, association, limited liability company or any other form or business association or other entity whatsoever, related to any vendor by blood, marriage, ownership or contract through which the party has a relationship of ownership or other interest with the vendor so that the party will actually or by effect receive or control a portion of the benefit, profit or other consideration from performance of a vendor contract with the party receiving an amount that meets or exceed five percent of the total contract amount.

EXCEPTION: The prohibition of this section does not apply where a vendor has contested any tax administered pursuant to chapter eleven of this code, workers' compensation premium, permit fee or environmental fee or assessment and the matter has not become final or where the vendor has entered into a payment plan or agreement and the vendor is not in default of any of the provisions of such plan or agreement.

LICENSING: Vendors must be licensed and in good standing in accordance with any and all state and local laws and requirements by any state or local agency of West Virginia, including, but not limited to, the West Virginia Secretary of State's Office, the West Virginia Tax Department, West Virginia Insurance Commission, or any other state agencies or political subdivision. Furthermore, the vendor must provide all necessary releases to obtain information to enable the Director or spending unit to verify that the vendor is licensed and in good standing with the above entities.

CONFIDENTIALITY: The vendor agrees that he or she will not disclose to anyone, directly or indirectly, any such personally identifiable information or other confidential information gained from the agency, unless the individual who is the subject of the information consents to the disclosure in writing or the disclosure is made pursuant to the agency's policies, procedures and rules. Vendors should visit www.state.wv.us/admin/purchase/privacy for the Notice of Agency Confidentiality Policies.

Under penalty of law for false swearing (West Virginia Code, §61-5-3), it is hereby certified that the vendor acknowledges the information in this said affidavit and are in compliance with the requirements as stated.

Vendor's Name: SMH Construction Co., Inc.

Authorized Signature: *Albuquerque* Date: 09-26-07

BID BOND

KNOW ALL MEN BY THESE PRESENTS, That we, the undersigned, SMH Construction Co., Inc.
of P.O. Box 1912, Beckley, WV 25802, as Principal and Travelers Casualty and Surety Company
of America of Hartford, Connecticut, a corporation organized and existing under the laws of the State of Connecticut
with its principal office in the City of Hartford, as Surety, are held and firmly bound unto the State
of West Virginia, as Obligee, in the penal sum of five percent of bid (\$ 5%) for the payment of which
well and truly to be made, we jointly and severally bind ourselves, our heirs administrators, executors, successors and assigns.

The Condition of the above obligation is such that whereas the Principal has submitted to the Purchasing Section of the
Department of Administration a certain bid or proposal, attached hereto and made a part hereof, to enter into a contract in writing for
Construction of concrete barrier walls for the West Virginia Army National Guard

NOW THEREFORE,

(a) If said bid shall be rejected, or
(b) If said bid shall be accepted and the Principal shall enter into a contract in accordance with the bid or proposal attached
hereto and shall furnish any other bonds and insurance required by the bid or proposal, and shall in all other respects perform the
agreement created by the acceptance of said bid, then this obligation shall be null and void, otherwise this obligation shall remain in full
force and effect. It is expressly understood and agreed that the liability of the Surety for any and all claims hereunder shall, in no event,
exceed the penal amount of this obligation as herein stated

The Surety, for the value received, hereby stipulates and agrees that the obligations of said Surety and its bond shall be in no
way impaired or affected by any extension of the time within which the Obligee may accept such bid, and said Surety does hereby
waive notice of any such extension

IN WITNESS WHEREOF, Principal and Surety have hereunto set their hands and seals, and such of them as are corporations
have caused their corporate seals to be affixed hereunto and these presents to be signed by their proper officers, this
26th day of September, 2007.

Principal Corporate Seal

SMH Construction Co., Inc.
(Name of Principal)
By [Signature]
(Must be President or
Vice President)
PRESIDENT
(Title)

Surety Corporate Seal

Travelers Casualty and Surety Company of America
(Name of Surety)
By: [Signature]
Attorney-in-Fact

IMPORTANT – Surety executing bonds must be licensed in West Virginia to transact surety insurance. Corporate seals must be affixed
and a power of attorney must be attached.



POWER OF ATTORNEY

Farmington Casualty Company
Fidelity and Guaranty Insurance Company
Fidelity and Guaranty Insurance Underwriters, Inc.
Seaboard Surety Company
St. Paul Fire and Marine Insurance Company

St. Paul Guardian Insurance Company
St. Paul Mercury Insurance Company
Travelers Casualty and Surety Company
Travelers Casualty and Surety Company of America
United States Fidelity and Guaranty Company

Attorney-In Fact No. 218346

Certificate No. 001700109

KNOW ALL MEN BY THESE PRESENTS: That Seaboard Surety Company is a corporation duly organized under the laws of the State of New York. that St Paul Fire and Marine Insurance Company, St Paul Guardian Insurance Company and St. Paul Mercury Insurance Company are corporations duly organized under the laws of the State of Minnesota that Farmington Casualty Company, Travelers Casualty and Surety Company, and Travelers Casualty and Surety Company of America are corporations duly organized under the laws of the State of Connecticut that United States Fidelity and Guaranty Company is a corporation duly organized under the laws of the State of Maryland. that Fidelity and Guaranty Insurance Company is a corporation duly organized under the laws of the State of Iowa, and that Fidelity and Guaranty Insurance Underwriters, Inc. is a corporation duly organized under the laws of the State of Wisconsin (herein collectively called the Companies), and that the Companies do hereby make. constitute and appoint

C. David Thomas, Richard L. Higginbotham, Bunnie Marie Perrine, Jeffery O'Dell, and Robin Hubbard-Sherrod

of the City of Charleston State of West Virginia their true and lawful Attorney(s)-in-Fact, each in their separate capacity if more than one is named above to sign, execute seal and acknowledge any and all bonds, recognizances, conditional undertakings and other writings obligatory in the nature thereof on behalf of the Companies in their business of guaranteeing the fidelity of persons guaranteeing the performance of contracts and executing or guaranteeing bonds and undertakings required or permitted in any actions or proceedings allowed by law

IN WITNESS WHEREOF the Companies have caused this instrument to be signed and their corporate seals to be hereto affixed, this 25th day of June 2007

Farmington Casualty Company
Fidelity and Guaranty Insurance Company
Fidelity and Guaranty Insurance Underwriters, Inc.
Seaboard Surety Company
St. Paul Fire and Marine Insurance Company

St. Paul Guardian Insurance Company
St. Paul Mercury Insurance Company
Travelers Casualty and Surety Company
Travelers Casualty and Surety Company of America
United States Fidelity and Guaranty Company



State of Connecticut
City of Hartford ss.

By: [Signature]
George W Thompson Senior Vice President

On this the 25th day of June 2007, before me personally appeared George W Thompson, who acknowledged himself to be the Senior Vice President of Farmington Casualty Company Fidelity and Guaranty Insurance Company, Fidelity and Guaranty Insurance Underwriters Inc., Seaboard Surety Company St Paul Fire and Marine Insurance Company, St Paul Guardian Insurance Company St Paul Mercury Insurance Company, Travelers Casualty and Surety Company, Travelers Casualty and Surety Company of America and United States Fidelity and Guaranty Company, and that he as such, being authorized so to do, executed the foregoing instrument for the purposes therein contained by signing on behalf of the corporations by himself as a duly authorized officer.

In Witness Whereof, I hereunto set my hand and official seal
My Commission expires the 30th day of June 2011



[Signature]
Marie C. Tetreault Notary Public

This Power of Attorney is granted under and by the authority of the following resolutions adopted by the Boards of Directors of Farmington Casualty Company, Fidelity and Guaranty Insurance Company, Fidelity and Guaranty Insurance Underwriters, Inc., Seaboard Surety Company, St. Paul Fire and Marine Insurance Company, St. Paul Guardian Insurance Company, St. Paul Mercury Insurance Company, Travelers Casualty and Surety Company, Travelers Casualty and Surety Company of America, and United States Fidelity and Guaranty Company, which resolutions are now in full force and effect, reading as follows:

RESOLVED, that the Chairman the President, any Vice Chairman, any Executive Vice President, any Senior Vice President, any Vice President, any Second Vice President, the Treasurer, any Assistant Treasurer, the Corporate Secretary or any Assistant Secretary may appoint Attorneys-in-Fact and Agents to act for and on behalf of the Company and may give such appointee such authority as his or her certificate of authority may prescribe to sign with the Company's name and seal with the Company's seal bonds, recognizances contracts of indemnity, and other writings obligatory in the nature of a bond, recognizance, or conditional undertaking, and any of said officers or the Board of Directors at any time may remove any such appointee and revoke the power given him or her; and it is

FURIHER RESOLVED, that the Chairman, the President, any Vice Chairman, any Executive Vice President any Senior Vice President or any Vice President may delegate all or any part of the foregoing authority to one or more officers or employees of this Company provided that each such delegation is in writing and a copy thereof is filed in the office of the Secretary; and it is

FURTHER RESOLVED that any bond, recognizance, contract of indemnity, or writing obligatory in the nature of a bond, recognizance, or conditional undertaking shall be valid and binding upon the Company when (a) signed by the President, any Vice Chairman, any Executive Vice President, any Senior Vice President or any Vice President, any Second Vice President, the Treasurer, any Assistant Treasurer, the Corporate Secretary or any Assistant Secretary and duly attested and sealed with the Company's seal by a Secretary or Assistant Secretary; or (b) duly executed (under seal if required) by one or more Attorneys-in-Fact and Agents pursuant to the power prescribed in his or her certificate or their certificates of authority or by one or more Company officers pursuant to a written delegation of authority; and it is

FURIHER RESOLVED that the signature of each of the following officers: President, any Executive Vice President, any Senior Vice President, any Vice President any Assistant Vice President, any Secretary, any Assistant Secretary, and the seal of the Company may be affixed by facsimile to any power of attorney or to any certificate relating thereto appointing Resident Vice Presidents, Resident Assistant Secretaries or Attorneys-in-Fact for purposes only of executing and attesting bonds and undertakings and other writings obligatory in the nature thereof, and any such power of attorney or certificate bearing such facsimile signature or facsimile seal shall be valid and binding upon the Company and any such power so executed and certified by such facsimile signature and facsimile seal shall be valid and binding on the Company in the future with respect to any bond or understanding to which it is attached.

I, Kori M Johanson, the undersigned, Assistant Secretary, of Farmington Casualty Company, Fidelity and Guaranty Insurance Company, Fidelity and Guaranty Insurance Underwriters, Inc., Seaboard Surety Company, St. Paul Fire and Marine Insurance Company, St. Paul Guardian Insurance Company, St. Paul Mercury Insurance Company, Travelers Casualty and Surety Company, Travelers Casualty and Surety Company of America, and United States Fidelity and Guaranty Company do hereby certify that the above and foregoing is a true and correct copy of the Power of Attorney executed by said Companies, which is in full force and effect and has not been revoked

IN TESTIMONY WHEREOF, I have hereunto set my hand and affixed the seals of said Companies this 26th day of SEPTEMBER, 2007

WARNING: THIS POWER OF ATTORNEY IS INVALID WITHOUT THE RED BORDER

Kori M Johanson
Kori M Johanson, Assistant Secretary



To verify the authenticity of this Power of Attorney, call 1-800-421-3880 or contact us at www.stpaultravelersbond.com Please refer to the Attorney-In-Fact number, the above-named individuals and the details of the bond to which the power is attached