



State of West Virginia
 Department of Administration
 Purchasing Division
 2019 Washington Street East
 Post Office Box 50130
 Charleston, WV 25305-0130

Request for Quotation

RFQ NUMBER
85803019

PAGE
1

ADDRESS CORRESPONDENCE TO ATTENTION OF
MICHAEL AUSTIN
304-558-2402

SUBJECT

GLEM COMPANY
P.O. Box 2109
CHARLESTON, WV 25328

SHIP TO

DIVISION OF HIGHWAYS
 JOBSITE
 SEE SPECIFICATIONS

| DATE PRINTED | TERMS OF SALE | SHIP VIA | F.O.B. | FREIGHT TERMS |
|--------------|---------------|----------|--------|---------------|
| 04/30/2008 | | | | |

BID OPENING DATE: **05/14/2008** BID OPENING TIME **01:30PM**

| LINE | QUANTITY | UOP | CAT NO | ITEM NUMBER | UNIT PRICE | AMOUNT |
|--|----------|-----|--------|-------------|------------|-----------|
| 0001 | 1 | LS | | 550-85 | 43,614.60 | 43,614.60 |
| <p>SUPPLY & INSTALL NEW POLE, AND RE-ATTACHED EXISTING</p> <p>TO PROVIDE AND INSTALL NEW POLE ON NEW FOUNDATION. RE-ATTACH EXISTING SIGNAL HEADS AND PEDESTRIAN PUSH BUTTON TO NEW POLE AND RE-CONNECT WIRING TO MAKE FUNCTION PROPERLY. ALL WORK TO BE PERFORMED IN ACCORDANCE WITH THE ATTACHED SPECIFICATIONS.</p> <p>RECEIVED 08 MAY 14 AM 11:28 PURCHASING DIVISION STATE OF WV</p> <p>EXHIBIT 5</p> <p>NOTICE TO PROCEED: THIS CONTRACT IS TO BE PERFORMED WITHIN 60 CALENDAR DAYS AFTER THE NOTICE TO PROCEED IS RECEIVED. UNLESS OTHERWISE SPECIFIED, THE FULLY EXECUTED PURCHASE ORDER WILL BE CONSIDERED NOTICE TO PROCEED.</p> <p>CANCELLATION: THE DIRECTOR OF PURCHASING RESERVES THE RIGHT TO CANCEL THIS CONTRACT IMMEDIATELY UPON WRITTEN NOTICE TO THE VENDOR IF THE MATERIALS OR WORKMANSHIP SUPPLIED ARE OF AN INFERIOR QUALITY OR DO NOT CONFORM WITH THE SPECIFICATIONS OF THE BID AND CONTRACT HERE IN.</p> <p>WAGE RATES: THE CONTRACTOR OR SUBCONTRACTOR SHALL PAY THE HIGHER OF THE U.S. DEPARTMENT OF LABOR MINIMUM WAGE RATES AS ESTABLISHED FOR BERKELEY COUNTY, PURSUANT TO WEST VIRGINIA CODE 21-5A, ET, SEQ. (PREVAILING WAGE RATES APPLY TO THIS PROJECT)</p> | | | | | | |

SEE REVERSE SIDE FOR TERMS AND CONDITIONS

| | | |
|--|---------------------------|-----------------------------------|
| SIGNATURE <i>Ken K. Hoffman, C.S.</i> | TELEPHONE 304-342-2721 | DATE 5/14/2008 |
| TITLE CORPORATE SECRETARY | FEIN 55-0179050 | ADDRESS CHANGES TO BE NOTED ABOVE |

WHEN RESPONDING TO RFQ, INSERT NAME AND ADDRESS IN SPACE ABOVE LABELED 'VENDOR'

**GENERAL TERMS & CONDITIONS
REQUEST FOR QUOTATION (RFQ) AND REQUEST FOR PROPOSAL (RFP)**

1. Awards will be made in the best interest of the State of West Virginia.
2. The State may accept or reject in part, or in whole, any bid.
3. All quotations are governed by the *West Virginia Code* and the *Legislative Rules* of the Purchasing Division.
4. Prior to any award, the apparent successful vendor must be properly registered with the Purchasing Division and have paid the required \$125.00 registration fee.
5. All services performed or goods delivered under State Purchase Orders/Contracts are to be continued for the term of the Purchase Order/Contract, contingent upon funds being appropriated by the Legislature or otherwise being made available. In the event funds are not appropriated or otherwise available for these services or goods, this Purchase Order/Contract becomes void and of no effect after June 30.
6. Payment may only be made after the delivery and acceptance of goods or services.
7. Interest may be paid for late payment in accordance with the *West Virginia Code*.
8. Vendor preference will be granted upon written request in accordance with the *West Virginia Code*.
9. The State of West Virginia is exempt from federal and state taxes and will not pay or reimburse such taxes.
10. The Director of Purchasing may cancel any Purchase Order/Contract upon 30 days written notice to the seller.
11. The laws of the State of West Virginia and the *Legislative Rules* of the Purchasing Division shall govern all rights and duties under the Contract, including without limitation the validity of this Purchase Order/Contract.
12. Any reference to automatic renewal is hereby deleted. The Contract may be renewed only upon mutual written agreement of the parties.
13. **BANKRUPTCY:** In the event the vendor/contractor files for bankruptcy protection, this Contract may be deemed null and void, and terminated without further order.
14. **HIPAA Business Associate Addendum -** The West Virginia State Government HIPAA Business Associate Addendum (BAA), approved by the Attorney General, and available online at the Purchasing Division's web site (<http://www.state.wv.us/admin/purchase/vrc/hipaa.htm>) is hereby made part of the agreement. Provided that, the Agency meets the definition of a Covered Entity (45 CFR §160.103) and will be disclosing Protected Health Information (45 CFR §160.103) to the vendor.

INSTRUCTIONS TO BIDDERS

1. Use the quotation forms provided by the Purchasing Division.
2. **SPECIFICATIONS:** Items offered must be in compliance with the specifications. Any deviation from the specifications must be clearly indicated by the bidder. Alternates offered by the bidder as **EQUAL** to the specifications must be clearly defined. A bidder offering an alternate should attach complete specifications and literature to the bid. The Purchasing Division may waive minor deviations to specifications.
3. Complete all sections of the quotation form.
4. Unit prices shall prevail in cases of discrepancy.
5. All quotations are considered F.O.B. destination unless alternate shipping terms are clearly identified in the quotation.
6. **BID SUBMISSION:** All quotations must be delivered by the bidder to the office listed below prior to the date and time of the bid opening. Failure of the bidder to deliver the quotations on time will result in bid disqualifications.

SIGNED BID TO:

Department of Administration
Purchasing Division
2019 Washington Street East
Post Office Box 50130
Charleston, WV 25305-0130



State of West Virginia
 Department of Administration
 Purchasing Division
 2019 Washington Street East
 Post Office Box 50130
 Charleston, WV 25305-0130

Request for Quotation

RFQ NUMBER
85803019

PAGE
2

ADDRESS CORRESPONDENCE TO ATTENTION OF
MICHAEL AUSTIN
304-558-2402

RFQ COPY
 TYPE NAME/ADDRESS HERE

DIVISION OF HIGHWAYS
 JOBSITE
 SEE SPECIFICATIONS

| DATE PRINTED | TERMS OF SALE | SHIP VIA | F.O.B. | FREIGHT TERMS |
|--------------|---------------|----------|--------|---------------|
| 04/30/2008 | | | | |

BID OPENING DATE: **05/14/2008** BID OPENING TIME **01:30PM**

| LINE | QUANTITY | UOP | CAT NO | ITEM NUMBER | UNIT PRICE | AMOUNT |
|---|----------|-----|--------|-------------|------------|--------|
| <p>ARBITRATION: ANY REFERENCES MADE TO ARBITRATION OR INTEREST FOR PAYMENTS DUE (EXCEPT FOR ANY INTEREST REQUIRED BY STATE LAW) CONTAINED IN THIS CONTRACT OR IN ANY AMERICAN INSTITUTE OF ARCHITECTS DOCUMENTS PERTAINING TO THIS CONTRACT ARE HEREBY DELETED.</p> <p>WORKERS' COMPENSATION: VENDOR IS REQUIRED TO PROVIDE A CERTIFICATE FROM WORKERS' COMPENSATION IF SUCCESSFUL.</p> <p>ALL OF THE ITEMS CHECKED BELOW WILL BE A REQUIREMENT OF THIS CONTRACT:</p> <p>(XX) INSURANCE: SUCCESSFUL VENDOR SHALL FURNISH PROOF OF COMMERCIAL GENERAL LIABILITY INSURANCE PRIOR TO ISSUANCE OF CONTRACT. UNLESS OTHERWISE SPECIFIED IN THE BID DOCUMENTS, THE MINIMUM AMOUNT OF INSURANCE COVERAGE REQUIRED IS \$250,000.</p> <p>() BUILDERS RISK INSURANCE: SUCCESSFUL VENDOR SHALL FURNISH PROOF OF BUILDERS RISK - ALL RISK INSURANCE IN AN AMOUNT EQUAL TO 100% OF THE AMOUNT OF THE CONTRACT.</p> <p>(XX) BONDS: FIVE PERCENT (5%) OF THE TOTAL AMOUNT OF THE BID PAYABLE TO THE STATE OF WEST VIRGINIA, SHALL BE SUBMITTED WITH EACH BID AS A BID BOND. THE SUCCESSFUL BIDDER SHALL ALSO FURNISH A PERFORMANCE BOND AND LABOR/MATERIAL BOND FOR 100% OF THE AMOUNT OF THE CONTRACT. BONDS MAY BE PROVIDED IN THE FORM OF A CERTIFIED CHECK, IRREVOCABLE LETTER OF CREDIT, OR BOND FURNISHED BY A SOLVENT SURETY COMPANY AUTHORIZED TO DO BUSINESS IN THE STATE OF WEST VIRGINIA. A LETTER OF CREDIT SUBMITTED IN LIEU OF A PERFORMANCE AND LABOR & MATERIAL BOND WILL ONLY BE ALLOWED FOR PROJECTS UNDER \$100,000. PERSONAL OR BUSINESS CHECKS ARE NOT ACCEPCTABLE IN LIEU OF THE 5% BID BOND, PERFORMANCE BOND, OR LABOR AND MATERIAL</p> | | | | | | |

SEE REVERSE SIDE FOR TERMS AND CONDITIONS

| | | |
|---|---------------------------|-----------------------------------|
| SIGNATURE <i>Ken K. Hoffmann, C.S.</i> | TELEPHONE 304-342-2721 | DATE 5/14/2008 |
| TITLE CORPORATE SECRETARY | FBI# 55-0179050 | ADDRESS CHANGES TO BE NOTED ABOVE |

WHEN RESPONDING TO RFQ, INSERT NAME AND ADDRESS IN SPACE ABOVE LABELED 'VENDOR'



State of West Virginia
 Department of Administration
 Purchasing Division
 2019 Washington Street East
 Post Office Box 50130
 Charleston, WV 25305-0130

Request for Quotation

RFQ NUMBER
85803019

PAGE
4

ADDRESS CORRESPONDENCE TO ATTENTION OF:
**MICHAEL AUSTIN
 304-558-2402**

VENDOR

RFQ COPY
 TYPE NAME/ADDRESS HERE

SHIP TO

DIVISION OF HIGHWAYS
 JOBSITE
 SEE SPECIFICATIONS

| DATE PRINTED | TERMS OF SALE | SHIP VIA | F.O.B. | FREIGHT TERMS |
|--------------|---------------|----------|--------|---------------|
| 04/30/2008 | | | | |

BID OPENING DATE: **05/14/2008** BID OPENING TIME **01:30PM**

| LINE | QUANTITY | UOP | CAT. NO. | ITEM NUMBER | UNIT PRICE | AMOUNT |
|---|----------|-----|----------|-------------|------------|--------|
| <p>ONLY IF DOMESTIC PRODUCTS ARE 30% OR MORE HIGHER IN PRICE THAN THE FOREIGN MADE PRODUCTS.</p> <p>IF, PRIOR TO THE AWARD OF A CONTRACT UNDER THE ABOVE PROVISIONS, THE SPENDING OFFICER OF THE SPENDING UNIT DETERMINES THAT THERE EXISTS A BID FOR LIKE FOREIGN ALUMINUM, GLASS OR STEEL THAT IS REASONABLE AND LOWER THAN THE LOWEST BID DOMESTIC PRODUCTS, THE SPENDING OFFICE MAY REQUEST, IN WRITING, A REEVALUATION AND REDUCTION IN THE LOWEST BID FOR SUCH DOMESTIC PRODUCTS. ALL VENDORS MUST INDICATE IN THEIR BID IF THEY ARE SUPPLYING FOREIGN ALUMINUM, GLASS OR STEEL.</p> <p>REV. 3/88</p> <p>EXHIBIT 9</p> <p>NOTICE FOR ISSUANCE & ACKNOWLEDGEMENT OF CONSTRUCTION PROJECT ADDENDA</p> <p>THE ARCHITECT/ENGINEER AND/OR AGENCY SHALL BE REQUIRED TO ABIDE BY THE FOLLOWING SCHEDULE IN ISSUING CONSTRUCTION PROJECT ADDENDA FOR STATE AGENCIES:</p> <p>(1) THE ARCHITECT/ENGINEER SHALL PREPARE THE ADDENDUM AND A LIST OF ALL PARTIES THAT HAVE PROCURED DRAWINGS AND SPECIFICATIONS FOR THE PROJECT. THE ADDENDUM AND LIST SHALL BE FORWARDED TO THE BUYER IN THE STATE PURCHASING DIVISION. THE ARCHITECT/ENGINEER SHALL ALSO SEND A COPY OF THE ADDENDUM TO THE STATE AGENCY FOR WHICH THE CONTRACT IS ISSUED.</p> <p>(2) THE BUYER SHALL SEND THE ADDENDUM TO ALL INTERESTED PARTIES AND, IF NECESSARY, EXTEND THE BID OPENING DATE. ANY ADDENDUM SHOULD BE RECEIVED BY THE</p> | | | | | | |

SEE REVERSE SIDE FOR TERMS AND CONDITIONS

| | | |
|--|---------------------------|-----------------------------------|
| SIGNATURE <i>Ron K. Hoffman, C.S.</i> | TELEPHONE 304-342-2721 | DATE 5/14/2008 |
| TITLE CORPORATE SECRETARY | FEBN 55-0179050 | ADDRESS CHANGES TO BE NOTED ABOVE |

WHEN RESPONDING TO RFQ, INSERT NAME AND ADDRESS IN SPACE ABOVE LABELED 'VENDOR'



State of West Virginia
 Department of Administration
 Purchasing Division
 2019 Washington Street East
 Post Office Box 50130
 Charleston, WV 25305-0130

Request for Quotation

RFQ NUMBER
85803019

PAGE
5

ADDRESS CORRESPONDENCE TO ATTENTION OF:
**MICHAEL AUSTIN
 304-558-2402**

RFQ COPY
 TYPE NAME/ADDRESS HERE

DIVISION OF HIGHWAYS
 JOBSITE
 SEE SPECIFICATIONS

PURCHASING

SHIP TO

| DATE PRINTED | TERMS OF SALE | SHIP VIA | F.O.B. | FREIGHT TERMS |
|--------------|---------------|----------|--------|---------------|
| 04/30/2008 | | | | |

BID OPENING DATE: **05/14/2008** BID OPENING TIME **01:30PM**

| LINE | QUANTITY | UOP | CAT NO | ITEM NUMBER | UNIT PRICE | AMOUNT |
|---|----------|-----|--------|-------------|------------|--------|
| <p>BUYER WITHIN FOURTEEN (14) DAYS PRIOR TO THE BID OPENING DATE.</p> <p>(3) ALL ADDENDA SHOULD BE FORMALLY ACKNOWLEDGED BY ALL BIDDERS AND SUBMITTED TO THE STATE PURCHASING DIVISION. THE SAME RULES AND REGULATIONS THAT APPLY TO THE ORIGINAL BIDDING DOCUMENT SHALL ALSO APPLY TO AN ADDENDUM DOCUMENT. THE ONLY EXCEPTION MAY BE FOR AN ADDENDUM THAT IS ISSUED FOR THE SOLE PURPOSE OF CHANGING A BID OPENING TIME AND/OR DATE.</p> <p>REV. 11/96</p> <p>EXHIBIT 10</p> <p>ADDENDUM ACKNOWLEDGEMENT</p> <p>I HEREBY ACKNOWLEDGE RECEIPT OF THE FOLLOWING CHECKED ADDENDUM(S) AND HAVE MADE THE NECESSARY REVISIONS TO MY PROPOSAL, PLANS AND/OR SPECIFICATION, ETC.</p> <p>ADDENDUM NOS.:</p> <p>NO. 1</p> <p>NO. 2</p> <p>NO. 3</p> <p>NO. 4</p> <p>NO. 5</p> <p>I UNDERSTAND THAT FAILURE TO CONFIRM THE RECEIPT OF TH</p> | | | | | | |

SEE REVERSE SIDE FOR TERMS AND CONDITIONS

| | | |
|--|---------------------------|-----------------------------------|
| SIGNATURE <i>Ron K. Hoggman, C.S.</i> | TELEPHONE 304-342-2721 | DATE 5/14/2008 |
| TITLE CORPORATE SECRETARY | FEIN 55-0179050 | ADDRESS CHANGES TO BE NOTED ABOVE |

WHEN RESPONDING TO RFQ, INSERT NAME AND ADDRESS IN SPACE ABOVE LABELED 'VENDOR'



State of West Virginia
 Department of Administration
 Purchasing Division
 2019 Washington Street East
 Post Office Box 50130
 Charleston, WV 25305-0130

Request for Quotation

RFQ NUMBER
85803019

PAGE
6

ADDRESS CORRESPONDENCE TO ATTENTION OF
**MICHAEL AUSTIN
 304-558-2402**

RFQ COPY
 TYPE NAME/ADDRESS HERE

DIVISION OF HIGHWAYS
 JOBSITE
 SEE SPECIFICATIONS

| DATE PRINTED | TERMS OF SALE | SHIP VIA | F.O.B. | FREIGHT TERMS |
|--------------|---------------|----------|--------|---------------|
| 04/30/2008 | | | | |

BID OPENING DATE: **05/14/2008** BID OPENING TIME **01:30PM**

| LINE | QUANTITY | UOP | CAT. NO. | ITEM NUMBER | UNIT PRICE | AMOUNT |
|---|----------|-----|----------|-------------|------------|--------|
| <p>ADDENDUM(S) MAY BE CAUSE FOR REJECTION OF THE BIDS.</p> <p>VENDOR MUST CLEARLY UNDERSTAND THAT ANY VERBAL REPRESENTATION MADE OR ASSUMED TO BE MADE DURING ANY ORAL DISCUSSION HELD BETWEEN VENDOR'S REPRESENTATIVES AND ANY STATE PERSONNEL IS NOT BINDING. ONLY THE INFORMATION ISSUED IN WRITING AND ADDED TO THE SPECIFICATIONS BY AN OFFICIAL ADDENDUM IS BINDING.</p> <p><i>Ren K. Hoffmann, Corp. Sec.</i>.....SIGNATURE <i>GLEM COMPANY</i>.....COMPANY <i>5/14/2008</i>.....DATE</p> <p>REV. 11/96</p> <p>CONTRACTORS LICENSE</p> <p>WEST VIRGINIA STATE CODE 21-11-2 REQUIRES THAT ALL PERSONS DESIRING TO PERFORM CONTRACTING WORK IN THIS STATE MUST BE LICENSED. THE WEST VIRGINIA CONTRACTORS LICENSING BOARD IS EMPOWERED TO ISSUE THE CONTRACTORS LICENSE. APPLICATIONS FOR A CONTRACTORS LICENSE MAY BE MADE BY CONTACTING THE WEST VIRGINIA DIVISION OF LABOR CAPITOL COMPLEX, BUILDING 3, ROOM 319, CHARLESTON, WV 25305. TELEPHONE: (304) 558-7890.</p> <p>WEST VIRGINIA STATE CODE 21-11-11 REQUIRES ANY PROSPECTIVE BIDDER TO INCLUDE THE CONTRACTORS LICENSE NUMBER ON THEIR BID.</p> <p>BIDDER TO COMPLETE:</p> <p>CONTRACTORS NAME: <i>GLEM COMPANY</i></p> | | | | | | |

SEE REVERSE SIDE FOR TERMS AND CONDITIONS

| | | |
|---|----------------------------------|-----------------------------------|
| SIGNATURE <i>Ren K. Hoffmann, C.S.</i> | TELEPHONE <i>304-342-2721</i> | DATE <i>5/14/2008</i> |
| TITLE <i>Corporate Secretary</i> | FEN <i>55-0179050</i> | ADDRESS CHANGES TO BE NOTED ABOVE |

WHEN RESPONDING TO RFQ, INSERT NAME AND ADDRESS IN SPACE ABOVE LABELED 'VENDOR'



State of West Virginia
 Department of Administration
 Purchasing Division
 2019 Washington Street East
 Post Office Box 50130
 Charleston, WV 25305-0130

Request for Quotation

| |
|------------|
| RFQ NUMBER |
| 85803019 |

| |
|------|
| PAGE |
| 7 |

| |
|---|
| ADDRESS CORRESPONDENCE TO ATTENTION OF: |
| MICHAEL AUSTIN 304-558-2402 |

RFQ COPY
 TYPE NAME/ADDRESS HERE

VENDOR

SHIP TO

DIVISION OF HIGHWAYS
 JOBSITE
 SEE SPECIFICATIONS

| DATE PRINTED | TERMS OF SALE | SHIP VIA | F.O.B. | FREIGHT TERMS |
|--------------|---------------|----------|--------|---------------|
| 04/30/2008 | | | | |

BID OPENING DATE: 05/14/2008 BID OPENING TIME 01:30PM

| LINE | QUANTITY | UOP | CAT NO | ITEM NUMBER | UNIT PRICE | AMOUNT |
|---|----------|-----|--------|-------------|------------|--------|
| | | | | | | |
| <p>CONTRACTORS LICENSE NO.: WV001795</p> <p>THE SUCCESSFUL BIDDER WILL BE REQUIRED TO FURNISH A COPY OF THEIR CONTRACTORS LICENSE PRIOR TO ISSUANCE OF A PURCHASE ORDER/CONTRACT</p> <p>APPLICABLE LAW</p> <p>THE WEST VIRGINIA STATE CODE, PURCHASING DIVISION RULES AND REGULATIONS, AND THE INFORMATION PROVIDED IN THE "REQUEST FOR QUOTATION" ISSUED BY THE PURCHASING DIVISION IS THE SOLE AUTHORITY GOVERNING THIS PROCUREMENT.</p> <p>ANY INFORMATION PROVIDED IN SPECIFICATION MANUALS, OR ANY OTHER SOURCE, VERBAL OR WRITTEN, WHICH CONTRADICTS OR ALTERS THE INFORMATION PROVIDED FROM THE SOURCES AS DESCRIBED IN THE ABOVE PARAGRAPH IS VOID AND OF NO EFFECT.</p> <p>BANKRUPTCY: IN THE EVENT THE VENDOR/CONTRACTOR FILES FOR BANKRUPTCY PROTECTION, THIS CONTRACT IS AUTOMATICALLY NULL AND VOID, AND IS TERMINATED WITHOUT FURTHER ORDER.</p> <p>REV. 1/2005</p> | | | | | | |
| <p>NOTICE</p> <p>A SIGNED BID MUST BE SUBMITTED TO:</p> <p>DEPARTMENT OF ADMINISTRATION PURCHASING DIVISION BUILDING 15</p> | | | | | | |

SEE REVERSE SIDE FOR TERMS AND CONDITIONS

| | | |
|--|---------------------------|-----------------------------------|
| SIGNATURE <i>Ron K. Hoffman, C.S.</i> | TELEPHONE 304-342-2721 | DATE 5/14/2008 |
| TITLE CORPORATE SECRETARY | FEIN 55-0179050 | ADDRESS CHANGES TO BE NOTED ABOVE |

WHEN RESPONDING TO RFQ, INSERT NAME AND ADDRESS IN SPACE ABOVE LABELED 'VENDOR'

SIGNAL WORK
I-81 SB RAMPS AT WV 51
INWOOD, BERKELEY CO.

SG-1

THE CONTRACTOR SHALL NOTIFY THE WVDOT DISTRICT 5 TRAFFIC ENGINEER
(RANDY SIGLEY / 304-289-2223) AND DISTRICT 5 AREA CONSTRUCTION ENGINEER
(KEN CLOHAN / 304-728-7333) AT LEAST 1 WEEK PRIOR TO BEGINNING WORK

ALL WORK MUST BE COMPLETED WITHIN 60 CALENDAR DAYS FROM 'NOTICE TO PROCEED'

| SIGNAL SUMMARY OF QUANTITIES | | | |
|-------------------------------------|--|------------------|-------|
| ITEM NO. | DESCRIPTION | QUANTITY UNIT | TOTAL |
| 636011-001 | TRAFFIC CONTROL DEVICE | UNIT | 2,460 |
| 636014-001 | FLAGGER | HOUR | 60 |
| 660001-002 | SIGNAL CONTROLLER, INSTALLATION ONLY, 02 | L.S. | 1 |
| 660002-020 | TRAFFIC DETECTOR, VTDS, 02 | L.S. | 1 |
| 660003-006 | SIGNAL SECTION, V-12 | EACH | 14 |
| 660004-041 | SIGNAL SUPPORT, INSTALLATION ONLY, C1 | EACH | 1 |
| 660007-001 | MISCELLANEOUS SIGNAL, 02 | L.S. | 1 |
| 660010-001 | PRIORITY CONTROL SYSTEM DETECTOR, D1 | EACH | 1 |
| 660060-001 | MISCELLANEOUS RADIO INSTALLATION | L.S. | 1 |
| 662007-001 | LUMINAIRE (250W) | EACH | 1 |

ESTIMATE OF QUANTITIES - 1/5 NO. 2 (WV 51 AT I-81 SB RAMPS)

| <u>LIST</u> | <u>QUANTITY</u> | <u>DESCRIPTION</u> |
|-------------|-----------------|---|
| 1 | 1 | POWER SERVICE (REWIRE EXISTING) |
| 2 | AS NEEDED | MESSENGER CABLE, TETHER CABLE |
| 3 | 1 X | STEEL STRAIN POLE (TYPE C1) W/ ANCHOR BOLTS |
| 3A | 1 | FOUNDATION |
| 4 | AS NEEDED | MISCELLANEOUS HARDWARE AND ITEMS |
| 5 | AS NEEDED | CONDUIT AND CONDUCTOR CABLE |
| 6 | 1 | ONE-WAY 5 SECTION 12" R.Y.G.: Y ← G ← : SW (NO. 1) |
| 7 | 1 | ONE-WAY 3 SECTION 12" R.Y.G.: SW (NO. 2) |
| 8 | 1 | TWO-WAY 3 SECTION 12" R.Y.G.: PM (NOs. 5 & 8) |
| 9 | 1 | LUMINAIRE-250W: 120/208/240/277 MULTI-TAP (LU 250/BD/S) TYPE III MEDIUM SEMI CUTOFF, HPS |
| 10 | 1 | VIDEO CAMERA - 660002-020, VTDS, 02 (1 LUM. ARM MTD.) |
| 11 | AS NEEDED | VIDEO CABLE AND VIDEO HARDWARE |
| 12 | 1 | PCS DETECTOR W/CONFIRMATION LIGHT & CABLE |
| 13 | 1 | RADIO ANTENNA (OMNI) W/ RADIO MAST |
| 14 | AS NEEDED | MISC. RADIO HARDWARE, RADIO CABLE |

X - POLE (1) ANCHOR BOLTS (4) TO BE SUPPLIED BY THE WVDOT

SIGNAL WORK - GENERAL NOTES

I-81 SB RAMPS AT WV 51 INWOOD, BERKELEY CO.

GOVERNING SPECIFICATIONS

1. THE WEST VIRGINIA DIVISION OF HIGHWAYS SPECIFICATIONS FOR ROADS AND BRIDGES ADOPTED 2000, AS AMENDED BY THE WVDOH SUPPLEMENTAL SPECIFICATIONS DATED JANUARY 1, 2003, THE CONTRACT DOCUMENTS AND THE CONTRACT PLANS ARE THE GOVERNING PROVISIONS APPLICABLE TO THIS PROJECT.
- 1A. THE NATIONAL ELECTRICAL CODE, STANDARDS OF THE NATIONAL BOARD OF FIRE UNDERWRITERS FOR ELECTRICAL WIRING AND APPARATUS.
2. "INSTALLATION OF THIS SIGNAL SYSTEM SHALL ONLY BE CONSIDERED SUBSTANTIALLY COMPLETE WHEN ALL PRESCRIBED SIGNAL SYSTEMS FUNCTIONS AND ROADWAY DETECTION SYSTEMS ARE OPERATIONAL".

GENERAL NOTES

3. REPLACEMENT OF ALL CONCRETE AND ASPHALT SHALL BE DONE IN ACCORDANCE TO ORIGINAL DESIGN THICKNESS WHERE IT HAS BEEN DISTURBED OR REMOVED TO INSTALL POLES OR CONDUIT AT THE CONTRACTOR'S EXPENSE.
4. ALL AREAS ON THIS PROJECT WHICH HAVE BEEN SEEDED BY OTHERS AND WHICH ARE DISTURBED BY THE CONTRACTOR IN PERFORMING THE REQUIREMENTS OF THIS CONTRACT SHALL BE REPLACED TO THEIR ORIGINAL CONDITION BY APPROVED SEEDING AND MULCHING METHODS AND MATERIALS AS DIRECTED BY THE ENGINEER. NO ADDITIONAL COMPENSATION SHALL BE ALLOWED FOR THIS WORK.
5. THE INFORMATION SHOWN ON THESE DRAWINGS CONCERNING TYPE AND LOCATION OF UNDERGROUND UTILITIES IS NOT GUARANTEED TO BE ACCURATE OR ALL INCLUSIVE. THE CONTRACTOR IS RESPONSIBLE FOR MAKING HIS OWN DETERMINATION AS TO THE TYPE AND LOCATION OF UNDERGROUND UTILITIES AS MAY BE NECESSARY TO AVOID DAMAGE THERETO. ANY DAMAGE INCURRED SHALL BE REPAIRED AT THE CONTRACTOR'S EXPENSE.
6. THE CONTRACTOR SHALL COORDINATE HIS ACTIVITIES WITH THE FOLLOWING AGENCIES IN THE INWOOD AREA:

| | | | | |
|-----------------------------|-----------|--------------------|-----------|--------------|
| ALLEGHENY POWER | — — — — — | MR. JEFFREY HUGHES | — — — — — | 267-3258 |
| VERIZON | — — — — — | MS. NANCY PAUL | — — — — — | 301-790-7126 |
| BERKELEY CO. P.S.D. (WATER) | — — — — — | MS. SYED IMRAN | — — — — — | 267-3855 |
| BERKELEY CO. SEWER DIST. | — — — — — | MR JOHN WOOD | — — — — — | 263-1819 |
| MOUNTAINEER GAS | — — — — — | MR TOM BYERS | — — — — — | 267-3220 |
7. COLOR CODING OF ELECTRICAL CONDUCTORS BY USE OF PHASE TAPE OR FIELD PAINT IS NOT ACCEPTABLE ON THIS PROJECT. CONDUCTORS MUST BE MANUFACTURER-COLORED, STRIPED OR RIGID-MARKED AS SPECIFIED.
8. ALL NEW METALLIC SIGNAL EQUIPMENT SUCH AS POLES, CONDUIT AND CABINETS MUST BE DIRECTLY BONDED TOGETHER BY A SPECIAL RUN SINGLE-CONDUCTOR *8 AWG STRANDED COPPER WIRE. THE WIRE MUST BE INSULATED, COLORED CODED GREEN AND CONNECTED AT EACH BONDING POINT BY USE OF SCREW-TYPE COPPER OR BRONZE LUGS. IN ADDITION TO THIS BONDING, CONDUCTOR MUST BE CONNECTED TO ALL GROUND RODS IN THE SIGNAL SYSTEM AND TO THE EQUIPMENT GROUND BAR BUSS IN THE CONTROLLER CABINET.
9. EXCAVATIONS FOR TRAFFIC SIGNAL CONDUIT NOT UNDER ROADWAY OR SHOULDER AREAS, UNDER 12" IN WIDTH AND 30" IN DEPTH, MAY BE BACKFILLED IN LAYERS NOT EXCEEDING 4" AFTER COMPACTION. SPECIFIC DENSITY TESTS WILL NOT BE REQUIRED WHEN ACCEPTED COMPACTION TECHNIQUES ARE USED AND THE BACKFILLED EXCAVATION DENSITY IS COMPARABLE TO THAT OF THE SURROUNDING GROUND.
10. UTILITY NOTE
THE CONTRACTOR MUST NOTIFY ALL APPLICABLE UTILITIES PRIOR TO ANY EXCAVATION FOR EXACT LOCATION OF THEIR UNDERGROUND FACILITIES. EXTREME CAUTION SHALL BE USED IN THESE AREAS ESPECIALLY IN EXCAVATING FOR FOUNDATIONS AND THE JACKING OF CONDUIT. IF NECESSARY THE CONTRACTOR SHALL HAND DIG TO LOCATE LINES OR SHALL OPEN CUT IN AREAS OF POSSIBLE CONFLICT. THESE AREAS TO BE DETERMINED BY THE PROJECT ENGINEER. CONTACT MISS UTILITY PRIOR TO ANY EXCAVATING.
11. TRAFFIC SIGNAL GROUND ROD CONNECTORS MUST BE ATTACHED AND SECURELY FASTENED BOTH AT FOUNDATION AND INSIDE POLE PRIOR TO ERECTION OF POLE. ENOUGH SLACK IN THE GROUNDING WIRE MUST BE ALLOWED FOR ERECTION OF POLE. BOTH CONNECTIONS MUST AGAIN BE CHECKED AFTER POLE IS INSTALLED.
12. ALL NEW POLE BASES SHALL BE PROVIDED WITH VARMINIT SCREENS.
13. SIGNAL HEAD CONDUCTOR CABLE
ALL SIGNAL HEAD CONDUCTOR CABLE SHALL BE IMSA BLACK PE, 20-1, 7-CONDUCTOR, 14 AWG STRANDED COPPER CABLE RATED AT 600V. THIS CONDUCTOR CABLE SHALL BE RED, ORANGE, GREEN, BLACK, WHITE, AND TWO (2) DIFFERING COLORS. IN ACCORDANCE WITH IMSA SPEC COLOR CODE.

SIGNAL WORK - GENERAL NOTES (cont.)
I-81 SB RAMPS AT WV 51
INWOOD, BERKELEY, CO.

SG-3

11

SIGNAL HEADS

1. ALL NEW SIGNAL HEADS FOR THIS PROJECT SHALL HAVE CUTAWAY VISORS, SIGNAL HEADS NO. 1 & 2 (1/S NO. 2) SHALL HAVE ALUMINUM BODIES, DOORS AND VISORS. ALSO, THESE NOTED SIGNAL HEADS SHALL HAVE BLACK, LOUVERED ALUMINUM BACKPLATES. ALL OTHER NEW SIGNAL HEADS IN THIS PROJECT SHALL BE NON-METALLIC AND NO BACKPLATES. ALL NEW BACKPLATES SHALL BE LOUVERED, BLACK AND SHALL HAVE A RETROREFLECTIVE 1" BORDER WITH A 1" MARGIN. THIS BORDER SHALL COMPRISE OF TYPE IX, FLOURESCENT YELLOW, PRESSURE SENSITIVE RETROREFLECTIVE SHEETING AND PLACED ON PERIMETER FACE OF ALL BACKPLATES.
- 2a. ALL NEW VEHICULAR SIGNAL SECTIONS SHALL UTILIZE LIGHT EMITTING DIODE (L.E.D.) SIGNAL MODULES AT 120 VAC. ALL UNITS SHALL NOT UTILIZE MORE THAN 22 WATTS POWER CONSUMPTION.
 - b. THESE L.E.D. MODULES SHALL BE CAPABLE OF RETROFITTING CURRENT NEMA TS-1 SIGNAL HEADS HOUSINGS.
 - c. ALL L.E.D. TRAFFIC SIGNAL MODULES SHALL BE BID INCIDENTAL TO ITEM 660003-006(V-12).
 - d. ALL TRAFFIC SIGNAL MODULES SHALL CONFORM TO THE WVDOH SPECIFICATION (SEE PROPOSAL) CONCERNING L.E.D. SIGNAL MODULES.
 - e. SEE THE WVDOH "APPROVED PRODUCTS LIST" (APL) FOR APPROVED LED MANUFACTURERS.
3. ALL LED'S SHALL CONFORM TO THE ITE VTC SH LED TRAFFIC SIGNAL LAMP, AS WELL AS THE ITE VTC SH PART 2: LED VEHICLE SIGNAL MODULES (INTERIM) SPECIFICATIONS.
4. VERTICAL CLEARANCE OF 18' (+ OR - 3") TO BE MAINTAINED TO THE BOTTOM OF ALL NEW SIGNAL HEADS.

POLES

1. NEW POLE COUPLINGS SHALL BE 3" WITH A WEATHERHEAD.
2. THE NEW TYPE C1 SIGNAL POLE (P6) IN THIS PROJECT AND ITS ANCHOR BOLTS ARE TO BE SUPPLIED BY THE WVDOH AND PICKED UP BY THE CONTRACTOR AT THE WVDOH SIGNAL SUPPLY YARD IN NITRO. THE CONTRACTOR IS TO SUPPLY EQUIPMENT TO LOAD POLE IN A MANNER AS TO NOT DAMAGE IT. AT LEAST FIVE (5) DAYS NOTICE SHALL BE GIVEN PRIOR TO PICK UP (PHONE 558-3063--BRUCE MILLER OR TED WHITMORE) THE METAL NO. TAGS MUST BE GIVEN TO WVDOH PERSONNEL PRIOR TO POLES LEAVING THE NITRO LOT. APPROVED WVDOH PERSONAL MUST BE ON SITE DURING PICK-UP OF POLES. THE CONTRACTOR SHALL SUPPLY SPAN WIRE CLAMPS, BRACKETS AND OTHER HARDWARE ITEMS NECESSARY FOR COMPLETION OF THIS PROJECT. BID INSTALLATION OF THIS POLE AS ITEM 660004-041.

TETHERING SIGNAL HEADS

NEW TETHER CABLE TO BE INSTALLED FOR ALL NEW CABLE MTD. SIGNAL HEADS USING AN ADJUSTABLE SIGNAL HANGAR AT BOTTOM OF EACH HEAD. THIS TETHER CABLE TO BE EQUAL TO THE ALIGNMENT OF THE NEW MESSENGER CABLE. CAUTION SHALL BE USED IN INSTALLING THIS TETHER CABLE, NEW HEADS TO BE PERPENDICULAR TO ROADWAY (NOT TILTED). TETHER CABLE TO NOT BE OUT OF PLUMB WITH MESSENGER CABLE BY MORE THAN 3". THE TETHER CABLE SHALL BE 1/8" STAINLESS AIRCRAFT CABLE. BID THIS WORK AND MATERIAL AS PART ITEM 660007-001() - * PER INTERSECTION SEE DETAIL 'E', SHEET SG-6. GALVANIZED CLAMPS SHALL BE USED TO ATTACH TETHER CABLE TO SIGNAL POLES.

LUMINAIRE WORK

1. NEW LUMINAIRE (1) TO BE SUPPLIED BY CONTRACTOR AND INSTALLED AS SHOWN IN THIS PROJECT (POLE P6). THIS NEW LUMINAIRE SHALL HAVE AN INTEGRAL PHOTOCCELL. THE 220-VOLT LUMINAIRE CIRCUIT SHALL BE PROTECTED BY A SEPARATE BREAKER PROVIDED IN THE SIGNAL POWER SERVICE ENCLOSURE. LUMINAIRE WIRING SHALL BE SUNLIGHT-RESISTANT, THREE CONDUCTOR #12 ISMA CABLE AND SHALL RUN CONTINUOUSLY WITH NO SPLICING OR IN-LINE FUSING. LUMINAIRE WIRING SHALL BE TAGGED AT ALL ACCESS POINTS. NEW LUMINAIRE WIRING TO BE INSTALLED TO THIS NEW LUMINAIRE (P6) AND ALSO TO THE EXISTING LUMINAIRE ON P8.
2. LUMINAIRE SHALL BE BID AS ITEM 662007-001(250). ALL ROADWAY LUMINAIRE WORK AND MATERIAL SHALL BE BID AS PART OF ITEM 660007-001(02).

SIGNAL WORK DESCRIPTION
I-81 SB RAMPS AT WV 51
INWOOD, BERKELEY CO.

1. THE CONTRACTOR SHALL REMOVE AND PROPERLY DISPOSE OF THE EXISTING SIGNAL POLE P6A, THE 2 POLE MTD. SIGNAL HEADS, ALL CONDUCTOR CABLE, THE P6- P7 AND P6- P5 MESSENGER CABLE. BID AS PART OF ITEM 660007-001(02).
2. THE EXISTING POLE P6A FOUNDATION SHALL BE REMOVED TO 12" BELOW GROUNDLINE AREA SITE GRADED. BID AS PART OF ITEM 660007-001(02).
- 2A. NEW POLE P6 AND ITS ANCHOR BOLTS SHALL BE SUPPLIED BY THE WVDOT AND INSTALLED WITH A NEW FOUNDATION BY THE CONTRACTOR AS SHOWN IN THESE PLANS. BID AS PART OF ITEM 660007-001(02).
- 2B. NEW CONDUIT SHALL BE INSTALLED FROM NEW FOUNDATION TO EXISTING CONTROLLER AS SHOWN IN THESE PLANS. BID AS PART OF ITEM 660007-001(02).
3. NEW MESSENGER CABLE AND CLAMPS TO BE INSTALLED FOR THE P6- P7 SPAN AND ALSO FOR THE P6- P5 SPAN. BID AS PART OF ITEM 660007-001(02)
4. THE EXISTING CONTROLLERS (LOCAL & MASTER) ARE 'EAGLE' AND SHALL BE REUSED. THESE SHALL BE REWIRED AS NECESSARY. PHASING SHALL BE AS SHOWN IN THESE PLANS. BID ALL NECESSARY CONTROLLER WORK AS ITEM 660001-002(02).
5. THE EXISTING POWER SERVICE IS LOCATED AS SHOWN ON PLANS AND SHALL BE REUSED. THE EXISTING POWER BREAKER ASSEMBLY ON EXISTING POLE P6A SHALL BE RELOCATED TO NEW POLE P6. NEW POWER SERVICE CABLE TO BE INSTALLED FROM THE EXISTING POWER BREAKER ASSEMBLY ON POLE P5 ACROSS NEW MESSENGER CABLE TO THE RELOCATED POWER BREAKER ASSEMBLY ON NEW POLE P6 AND THEN INTO EXISTING CONTROLLER AND PROPERLY ATTACHED. BID AS PART OF ITEM 660007-001(02).
6. NEW SIGNAL HEADS NO. 1, 2, 5 & 8 ARE TO BE SUPPLIED AND INSTALLED BY THE CONTRACTOR AND AS SHOWN IN THESE PLANS. BID AS ITEM 660003-006(V-12). SIGNAL HEADS NO. 3, 4, 6 & 7 ARE EXISTING TO REMAIN.
7. NEW CONDUCTOR CABLE TO BE INSTALLED TO ALL NEW AND EXISTING SIGNAL HEADS. BID AS PART OF ITEM 660007-001(02).
8. THE EXISTING LUMINAIRE ARM ON EXISTING POLE P6A SHALL BE RELOCATED TO NEW POLE P6. THIS ARM TO BE STRAIGHTENED, AS MUCH AS POSSIBLE, BY CONTRACTOR PRIOR TO INSTALLATION. BID AS PART OF ITEM 660007-001(02).
9. A NEW LUMINAIRE TO SUPPLIED AND INSTALLED BY CONTRACTOR ON POLE P6. THIS LUMINAIRE AND THE EXISTING LUMINAIRE ON POLE P8 SHALL HAVE NEW CONDUCTOR CABLE INSTALLED TO THEM TO MAKE THEM FUNCTION PROPERLY.
10. A NEW PRIORITY CONTROL SYSTEM DETECTOR TO BE SUPPLIED AND INSTALLED BY THE CONTRACTOR WITH NEW CONDUCTOR CABLE AS SHOWN IN THESE PLANS. BID AS ITEM 660010-001.
11. A NEW SPREAD SPECTRUM RADIO ANTENNA (OMNI) SHALL BE SUPPLIED AND INSTALLED ON POLE P6 BY CONTRACTOR. NEW RADIO CABLE TO BE INSTALLED FROM THIS ANTENNA DOWN POLE AND INTO EXISTING CABINET TO THE EXISTING RADIO TRANSCEIVER AND ATTACHED TO MAKE SYSTEM FUNCTION PROPERLY. BID THIS WORK AND MATERIAL AS ITEM 660060-001.
12. A NEW VIDEO CAMERA (VID 8) TO BE SUPPLIED AND INSTALLED BY CONTRACTOR ON NEW POLE P6 AS SHOWN IN THESE PLANS. NEW VIDEO CONDUCTOR CABLE TO BE INSTALLED TO ALL VIDEO CAMERAS (4). BID THIS WORK AND MATERIAL AS ITEM 660002-020.VTDS, 02. THE VIDEO PROCESSING UNIT IS EXISTING TO BE REUSED WITHIN CONTROLLER CABINET.
13. NEW PHONE LINE TO BE ATTACHED AT 'CUSTOMER CONNECTION BOX' AND INSTALLED AS NECESSARY TO THE CONTROLLER AND ATTACHED TO MAKE FUNCTION PROPERLY. BID AS PART OF ITEM 660007-001(02).
14. NEW TETHER CABLE TO BE INSTALLED FOR ALL NEW CABLE MTD. SIGNAL HEADS. BID AS PART OF ITEM 660007-001(02).
15. THE CONTRACTOR SHALL DELIVER THE EXISTING PCS DETECTOR AND THE EXISTING OMNI ANTENNA TO THE CENTRAL SIGNAL SHOP ON DRY BRANCH RD NEAR CHARLESTON.
16. FINAL INSPECTION TO BE PERFORMED BY THE WVDOT TRAFFIC ENGINEERING DIVISION (558-3063).

NOTE:

THIS INTERSECTION SHALL BE TOTALLY REWIRED WITH NEW CONDUCTOR CABLE. THIS INCLUDES ALL SIGNAL HEADS, VIDEO CAMERAS, PCS DETECTOR, RADIO CABLE, LUMINAIRES AND POWER SERVICE FROM BREAKER ASSEMBLY ON POLE P5. (NO EXISTING FIELD WIRING SHALL BE REUSED)

VIDEO TRAFFIC DETECTION SYSTEM (VTDS)

A VIDEO TRAFFIC DETECTION SYSTEM (VTDS) IS TO BE INSTALLED FOR THIS INTERSECTION AS DESCRIBED IN THESE PLANS.
THIS SHALL BE BID PER INTERSECTION [660002-020, TRAFFIC DETECTORS VTDS, (*)]
THIS INTERSECTION SYSTEM INCLUDES THE NECESSARY CAMERA, CABLE AND RELATED HARDWARE TO MAKE FUNCTION PROPERLY. SEE VIDEO SPECIFICATIONS IN PROPOSAL AND DETAIL 'G' ON SHEET SG-6.

TRAFFIC CONTROL PLAN NOTES
I-81 SB RAMPS AT WV 51
INWOOD, BERKELEY CO.

SG-5 13

MAINTENANCE OF TRAFFIC NOTES

1. MAINTENANCE OF TRAFFIC SHALL BE IN ACCORDANCE WITH SECTION 636 OF THE WEST VIRGINIA DEPARTMENT OF TRANSPORTATION, DIVISION OF HIGHWAYS STANDARD SPECIFICATIONS ROADS AND BRIDGES, ADOPTED 2000, AND THE WEST VIRGINIA DEPARTMENT OF TRANSPORTATION, DIVISIONS OF HIGHWAYS SUPPLEMENTAL SPECIFICATIONS DATED JANUARY 1, 2003 AND THE "MANUAL ON TEMPORARY TRAFFIC CONTROL FOR STREETS AND HIGHWAYS" 2006 EDITION; WHICH IS MADE A PART OF THIS CONTRACT AND THE TRAFFIC PLAN FOR FOR INDIVIDUAL SEGMENTS AS DESCRIBED IN THESE PLANS.
2. REFLECTIVE SHEETING ON TEMPORARY TRAFFIC CONTROL DEVICES SHALL BE OF NEW CONDITION AT THE BEGINNING OF THE PROJECT LIFE. NIGHT VISIBILITY AND LEGIBILITY SHALL BE MAINTAINED. ALL WARNING SIGNS SHALL HAVE MINIMUM DIMENSIONS OF 48" X 48" UNLESS OTHERWISE NOTED. SIGN SIZES AND COLORS ARE SHOWN IN THE WEST VIRGINIA DIVISION OF HIGHWAYS SIGN FABRICATION MANUAL.
3. ACCESS TO ALL HOUSES AND BUSINESSES SHALL BE MAINTAINED AT ALL TIMES.
4. TRAFFIC SHALL BE MAINTAINED THROUGHOUT THE PROJECT AT ALL TIMES.
5. OPEN HOLES TO BE COVERED AND HAVE TYPE II BARRICADES w/TYPE 'A' LIGHTS. THERE IS NO SPECIFIC BID ITEM FOR TYPE 'A' LIGHTS SHALL BE BID INCIDENTAL TO ITEM 636011-001.
6. ALL SIGNS INDICATING "ROAD CONSTRUCTION" SHALL NOW READ "ROAD WORK". FOR EXAMPLE, THE W-20-1 "ROAD CONSTRUCTION NEXT MILES", SHALL READ "ROAD WORK NEXT MILES", AND G20-2 "END CONSTRUCTION" SHALL READ "END ROAD WORK".
7. ALL WORK THROUGH OUT THE LIFE OF THIS PROJECT SHALL BE CO-ORDINATED WITH THE AREA ACTIVITIES TO MINIMIZE EFFECTS ON TRAFFIC FLOW, ESPECIALLY FOR ANY 'SPECIAL EVENTS'. CONTRACTOR SHALL NOTE THESE 'SPECIAL EVENTS' IN ADVANCE TO MINIMIZE DISRUPTIONS.

SEQUENCE OF CONSTRUCTION

1. NON-ROAD - USE CASE A3 OR A4 WITHOUT TYPE 'B' LIGHTS FOR ONE, TWO, THREE, OR FOUR APPROACHES AS NECESSARY.

IN ROADWAY - USE CASES B1, B2, B4A, OR B4B AS APPROPRIATE. DO NOT CLOSE LANES OVERNIGHT.

NOTE: FOR PEDESTRIANS, INSTALL "WORKERS" (W21-1a) SIGNS, TYPE II BARRICADES OR DRUMS, CONSTRUCTION TAPE, AND TYPE 'A' LIGHT OR TYPE II BARRICADE OR DRUM FOR OVERNIGHT AS NECESSARY.
2. CONSTRUCTION OF INDIVIDUAL INTERSECTION.

SIGNAL DETAIL SHEET
I-81 SB RAMPS AT WV 51
INWOOD, BERKELEY CO.

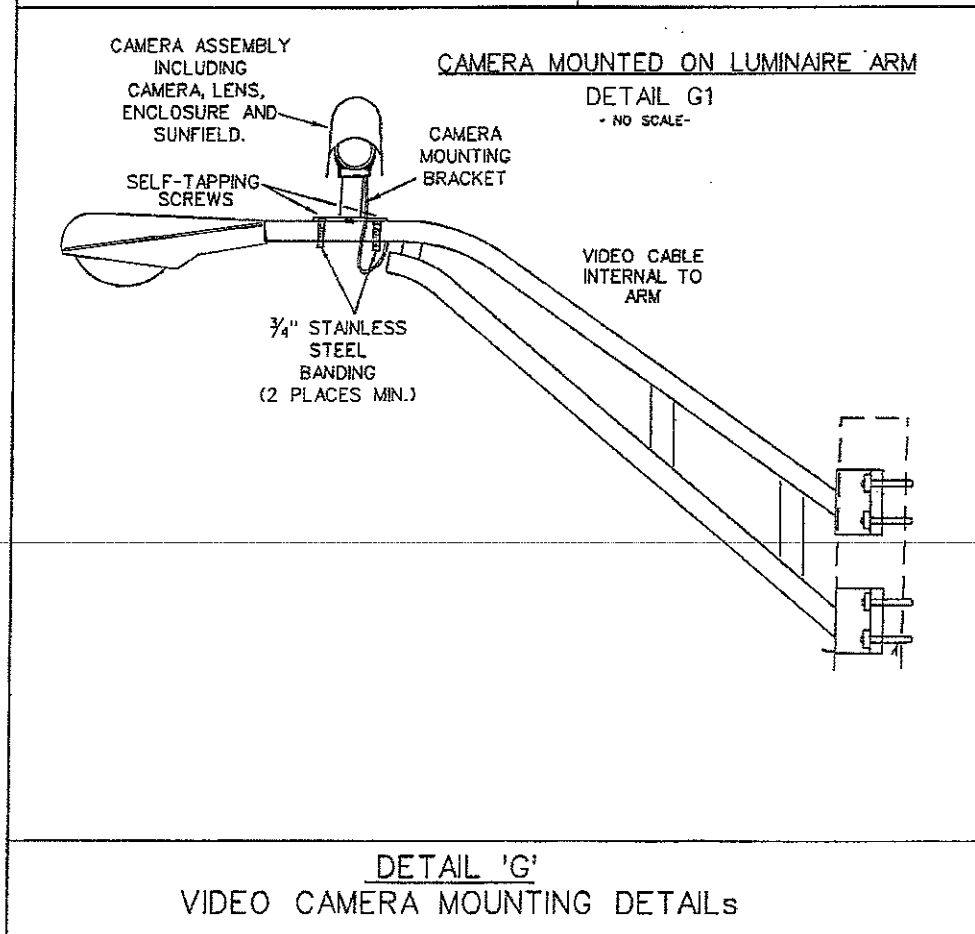
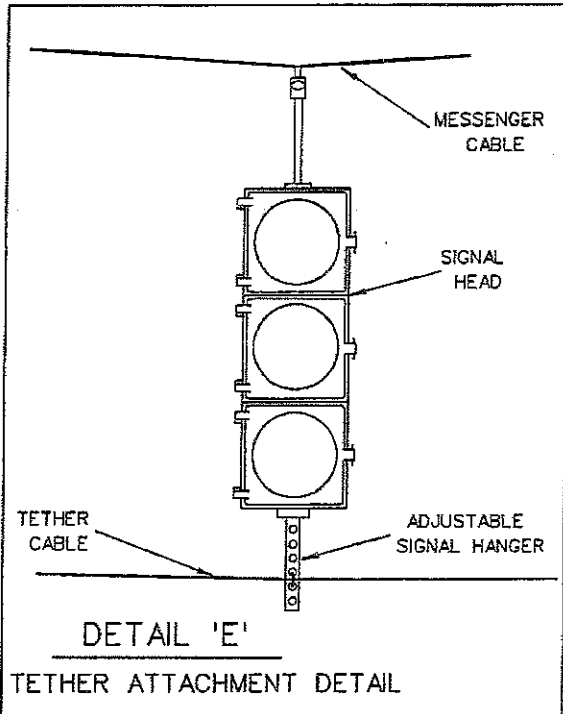

PCS DETAIL SHEET
I-81 SB RAMPS AT WV 51
INWOOD, BERKELEY CO.

SG-7 15

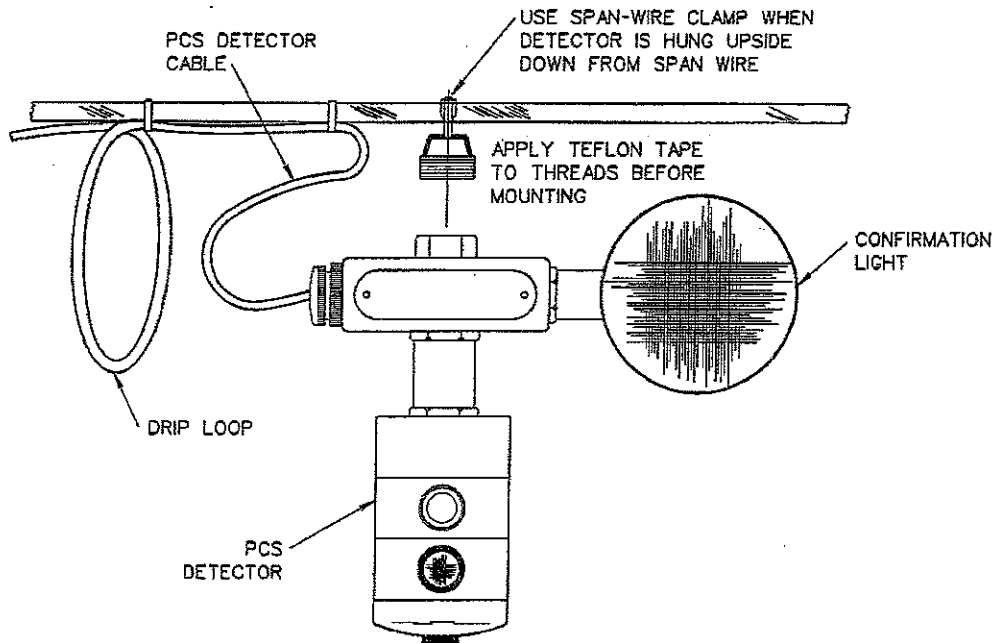

PCS SPAN WIRE INSTALLATION

1. WEEP HOLE(S) MUST BE REMOVED PRIOR TO INSTALLATION. CONTRACTOR IS FULLY LIABLE FOR EQUIPMENT REPLACEMENT DUE TO CORROSION.
2. A DRIP LOOP IS TO BE PROVIDED ADJACENT TO RECEIVER.
3. TEFLON TAPE IS TO BE USED ON ALL PCS RECEIVER THREADED CONNECTIONS.

PRIORITY CONTROL SYSTEM (PCS)

BID AS ITEM 660010-001() - SEE BELOW

THE PRIORITY CONTROL SYSTEM SHALL PROVIDE ADVANCE SIGNAL CONTROL PER INTERSECTION APPROACH AS SHOWN ON THE PLAN SHEETS. THE SYSTEM CONSISTS OF 1 NEW DETECTOR w/CONFIRMATION LIGHT, 1 EXISTING TO BE REWIRED AS NECESSARY CARD RACK MOUNTED SIGNAL INTERFACE UNIT AND ALL NECESSARY PCS WIRING. THIS ALSO INCLUDES MOUNTING HARDWARE AND OTHER HARDWARE ITEMS TO COMPLETE SYSTEM.

AN EMITTER MOUNTED ON A PRIORITY VEHICLE TRANSMITS A SHAPED, OPTICAL PATTERN OF CODED LIGHT TO A DETECTOR AT THE PRIORITIZED INTERSECTION APPROACH. THE INTERFACE UNIT WILL THEN INPUT A CALL TO THE CONTROLLER FOR A PROGRAMMED PREEMPTION ROUTINE. THE TRANSMIT/RECEIVE DISTANCE FOR EACH INTERSECTION APPROACH MUST BE USER PROGRAMMABLE AND WILL BE THE RESPONSIBILITY OF THE DIVISION OF HIGHWAYS TO BE DETERMINE AND SET. A MEANS FOR ADJUSTMENT OF THE TRANSMIT/RECEIVE DISTANCE PER APPROACH MUST BE PROVIDED WITH THE SYSTEM.

BID ALL PCS WORK AND MATERIAL AS ITEM 660010-001(D1)

NEW PCS DETECTOR SHALL BE THE SAME TYPE AND ON THE SAME FREQUENCY AS THE EXISTING PCS DETECTOR AT I/S NO. 1 (I-81 NB RAMPS/ WV 51).

SPREAD SPECTRUM RADIO DETAIL SHEET

I-81 SB RAMPS AT WV 51 INWOOD, BERKELEY CO.

INSTALLATION OF "SPREAD SPECTRUM RADIO SYSTEM"

THESE TWO INTERSECTIONS ARE INTERCONNECTED BY MEANS OF SPREAD SPECTRUM RADIO INTERCONNECT. THERE IS AN EXISTING RADIO TRANSCEIVER WITHIN THE EXISTING MASTER CONTROLLER CABINET (NEAR P6).

MASTER CONTROLLER

THIS EXISTING MASTER CONTROLLER AT I/S NO. 2 (WV 51 AT I-81 SB RAMPS) SHALL BE CAPABLE OF COMMUNICATING TO BOTH LOCAL INTERSECTIONS (I-81 SB RAMPS & I-81 NB RAMPS) BY SPREAD SPECTRUM RADIO INTERCONNECT.

THIS MASTER CONTROLLER LOCATION SHALL HAVE A NEW MASTER ANTENNA (Omni-Directional) ON POLE P6 WITH ANTENNA MAST AND ANTENNA CABLE (HARDLINE) INSTALLED DOWN POLE TO THE EXISTING RADIO TRANSCEIVER WITHIN CABINET. ALL (2) LOCAL INTERSECTIONS SHALL BE RESPONSIVE TO THE MASTER CONTROLLER.

RADIO CABLE TO BE INSTALLED THRU NEW 3" CONDUIT, INTO CONTROLLER PRIOR TO INSTALLING ANY OTHER CABLE.

ALL MATERIAL AND WORK REQUIRED TO INSTALL THIS RADIO SPREAD SPECTRUM SYSTEM TO BE BID AS 660060-001. THIS INCLUDES:

- A) ANTENNA (1) F) MISC. HARDWARE & ITEMS
- B) ANTENNA MAST (1) G) TESTING
- C) RADIO CABLE
- D) LIGHTNING PROTECTION
- E) MODEM SPLITTERS

- NO SCALE -

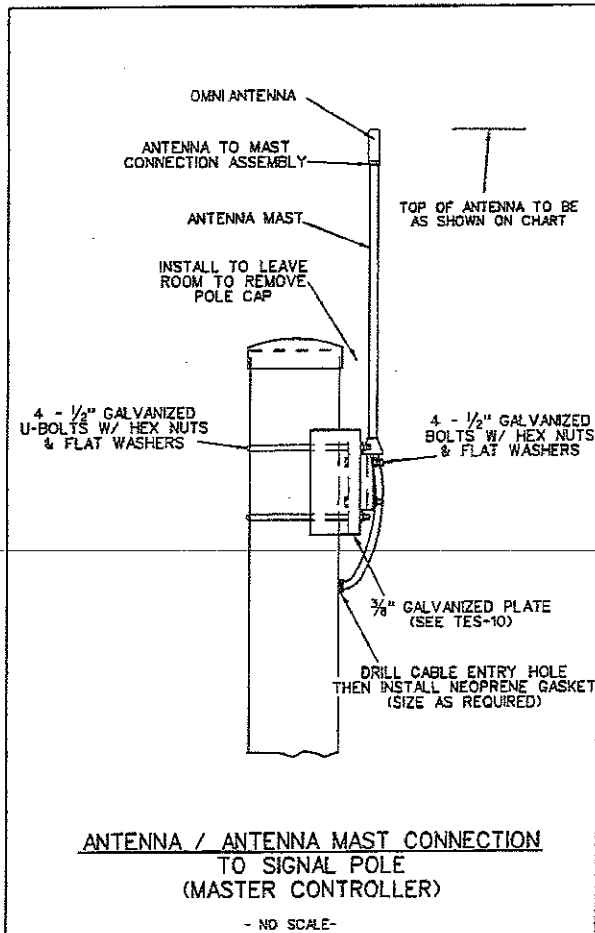

DISTANCE TO TOP OF ANTENNA FROM GROUND LINE

| I/S NO. | POLE NO. | POLE HEIGHT | TOP OF ANTENNA HEIGHT |
|---------------|----------|-------------|-----------------------|
| 2 (MASTER) | P6 | 32' | 37' |

SIGNAL INFORMATION SHEET
I-81 SB RAMPS AT WV 51
INWOOD, BERKELEY CO.

POLE CHART

| FOOTER OR POLE NO. | TYPE | UPRIGHT POLE | | | | | LOCATION | LUMINAIRE | |
|-----------------------|------|--------------------------------------|---------|--------|----------|--------|-------------------|-----------|-------------|
| | | POLE MOUNTED SIGNAL ATTACHMENT | | HEIGHT | WALL GA. | O. D. | | MTG. HGT. | SPREAD |
| | | DIM "K" | DIM "L" | | | | | | |
| P5 | C1 | 12' | 3'-10" | 32' | 3 | 14.75" | EX. TO REMAIN | 38'-6" | 20' No Lum. |
| P6 | C1 | | | 32' | 3 | 14.75" | NEW AS INDICATED | 38'-6" | 20' w/Lum. |
| P7 | C1 | | | 32' | 3 | 14.75" | EX. TO REMAIN | | |
| P8 | C1 | | | 32' | 3 | 14.75" | EX. TO REMAIN | 38'-6" | 20' w/Lum. |
| P6A | C1 | | | 32' | 3 | 14.75" | EX. TO BE REMOVED | 38'-6" | 20' w/Lum. |

- POLE P6 AND ITS ANCHOR BOLTS ARE TO BE SUPPLIED BY THE WVD0H

DUAL RING PHASING

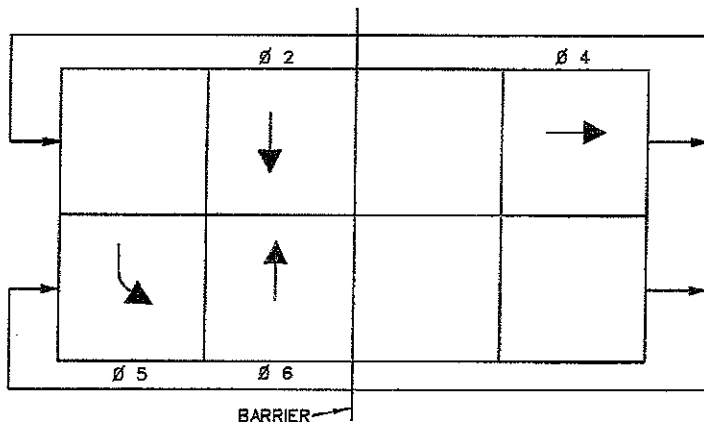

I/S# 2 PCS
ALSO SEE PCS NOTES ON SHEET 8
& SPECIAL PROVISIONS

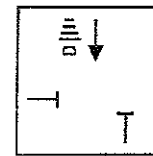

PCS 2
DWELL

- THIS CONTROLLER UTILIZES DUAL ENTRY

SIGNAL HEADS

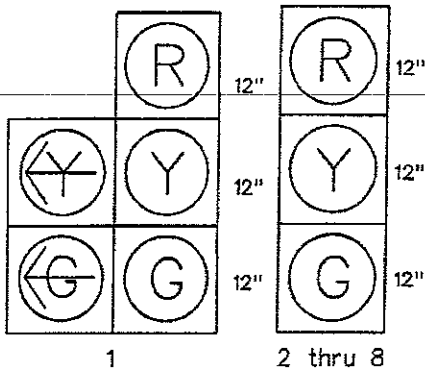

FLASH SEQUENCE

| HEAD NO. | FLASH |
|-----------------|-------|
| 1, 2 3, 4, 5 | Y |
| 6, 7, 8 | R |

- SIGNAL HEADS NO. 3, 4, 6 & 7 ARE EXISTING TO REMAIN AND BE REWIRED
- SIGNAL HEADS NO. 1, 2, 5 & 8 ARE NEW TO BE SUPPLIED AND INSTALLED BY THE CONTRACTOR AND BE REWIRED.

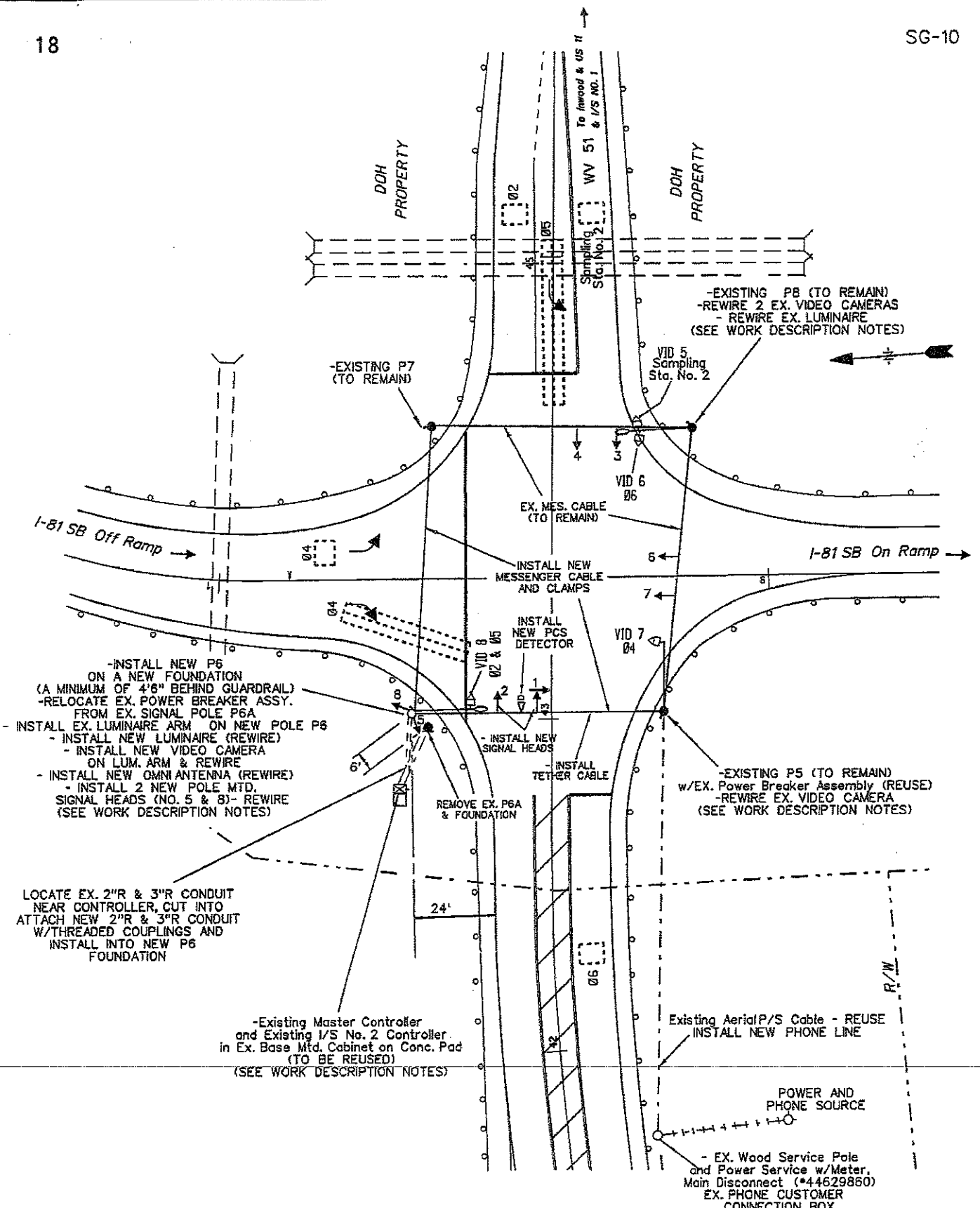

-INSTALL NEW P6 ON A NEW FOUNDATION (A MINIMUM OF 4'6" BEHIND GUARDRAIL)
 -RELOCATE EX. POWER BREAKER ASSY. FROM EX. SIGNAL POLE P6A
 -INSTALL EX. LUMINAIRE ARM ON NEW POLE P6
 -INSTALL NEW LUMINAIRE (REWIRE)
 -INSTALL NEW VIDEO CAMERA ON LUM. ARM & REWIRE
 -INSTALL NEW OMNI ANTENNA (REWIRE)
 -INSTALL 2 NEW POLE MTD. SIGNAL HEADS (NO. 5 & 8) - REWIRE (SEE WORK DESCRIPTION NOTES)

-EXISTING P8 (TO REMAIN)
 -REWIRE 2 EX. VIDEO CAMERAS
 -REWIRE EX. LUMINAIRE
 (SEE WORK DESCRIPTION NOTES)

-EXISTING P5 (TO REMAIN) w/EX. Power Breaker Assembly (REUSE)
 -REWIRE EX. VIDEO CAMERA
 (SEE WORK DESCRIPTION NOTES)

LOCATE EX. 2"R & 3"R CONDUIT NEAR CONTROLLER, CUT INTO ATTACH NEW 2"R & 3"R CONDUIT W/THREADED COUPLINGS AND INSTALL INTO NEW P6 FOUNDATION

-Existing Master Controller and Existing I/S No. 2 Controller in Ex. Base Mtd. Cabinet on Conc. Pad (TO BE REUSED)
 (SEE WORK DESCRIPTION NOTES)

Existing Aerial P/S Cable - REUSE
 INSTALL NEW PHONE LINE

POWER AND PHONE SOURCE

- EX. Wood Service Pole and Power Service w/Meter, Main Disconnect (*44629860)
 EX. PHONE CUSTOMER CONNECTION BOX

LEGEND

- | | | | |
|---|------------------------|-----|-------------------------|
| ☐ | CONTROLLER | PCS | PRIORITY CONTROL SYSTEM |
| ○ | SIGNAL POLE (PROPOSED) | ▷ | PCS DETECTOR |
| ● | SIGNAL POLE (EXISTING) | ◁ | PCS EMITTER |
| → | TRAFFIC SIGNAL HEAD | ◀ | VIDEO CAMERA |
| ○ | LUMINAIRE | ⋯ | DETECTION ZONE |
| ⊕ | UTILITY POLE | | |

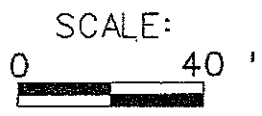

I/S #2

SIGNAL WORK LAYOUT
 I-81 SB RAMP AT WV 51
 INWOOD, BERKELEY CO.

STATE OF WEST VIRGINIA
Purchasing Division

PURCHASING AFFIDAVIT

West Virginia Code §5A-3-10a states: No contract or renewal of any contract may be awarded by the state or any of its political subdivisions to any vendor or prospective vendor when the vendor or prospective vendor or a related party to the vendor or prospective vendor is a debtor and the debt owed is an amount greater than one thousand dollars in the aggregate

DEFINITIONS:

"Debt" means any assessment, premium, penalty, fine, tax or other amount of money owed to the state or any of its political subdivisions because of a judgment, fine, permit violation, license assessment, defaulted workers' compensation premium, penalty or other assessment presently delinquent or due and required to be paid to the state or any of its political subdivisions, including any interest or additional penalties accrued thereon.

"Debtor" means any individual, corporation, partnership, association, limited liability company or any other form or business association owing a debt to the state or any of its political subdivisions. "Political subdivision" means any county commission; municipality; county board of education; any instrumentality established by a county or municipality; any separate corporation or instrumentality established by one or more counties or municipalities, as permitted by law; or any public body charged by law with the performance of a government function or whose jurisdiction is coextensive with one or more counties or municipalities. "Related party" means a party, whether an individual, corporation, partnership, association, limited liability company or any other form or business association or other entity whatsoever, related to any vendor by blood, marriage, ownership or contract through which the party has a relationship of ownership or other interest with the vendor so that the party will actually or by effect receive or control a portion of the benefit, profit or other consideration from performance of a vendor contract with the party receiving an amount that meets or exceeds five percent of the total contract amount.

EXCEPTION: The prohibition of this section does not apply where a vendor has contested any tax administered pursuant to chapter eleven of this code, workers' compensation premium, permit fee or environmental fee or assessment and the matter has not become final or where the vendor has entered into a payment plan or agreement and the vendor is not in default of any of the provisions of such plan or agreement.

LICENSING: Vendors must be licensed and in good standing in accordance with any and all state and local laws and requirements by any state or local agency of West Virginia, including, but not limited to, the West Virginia Secretary of State's Office, the West Virginia Tax Department, West Virginia Insurance Commission, or any other state agencies or political subdivision. Furthermore, the vendor must provide all necessary releases to obtain information to enable the Director or spending unit to verify that the vendor is licensed and in good standing with the above entities.

CONFIDENTIALITY: The vendor agrees that he or she will not disclose to anyone, directly or indirectly, any such personally identifiable information or other confidential information gained from the agency, unless the individual who is the subject of the information consents to the disclosure in writing or the disclosure is made pursuant to the agency's policies, procedures and rules. Vendors should visit www.state.wv.us/admin/purchase/privacy for the Notice of Agency Confidentiality Policies.

Under penalty of law for false swearing (West Virginia Code, §61-5-3), it is hereby certified that the vendor acknowledges the information in this said affidavit and are in compliance with the requirements as stated.

Vendor's Name: _____

Authorized Signature: _____ Date: _____

THIS CHECK IS PRINTED ON CHEMICAL REACTIVE PAPER WHICH CONTAINS A WATERMARK - VERIFY FOR AUTHENTICITY

City
NATIONAL BANK

NOTICE TO CUSTOMERS: THE PURCHASE OF AN INDEMNITY BOND
WILL BE REQUIRED BEFORE ANY OFFICIAL CHECK OF THIS BANK
WILL BE REPLACED OR REFUNDED IN THE EVENT IT IS LOST MISPLACED
OR STOLEN - ANY QUESTIONS PLEASE CALL (304) 769-1320

CASHIERS CHECK

10019821

Date: 5/14/08

Branch: 0010

REMITTER GLEM COMPANY

**PAY
TO THE**

EXACTLY **2,180 AND 73/100 DOLLARS

\$2,180.73

ORDER OF STATE OF WEST VIRGINIA DIVISION OF HIGHWAYS

BID BOND

Sony W. Childers

