



State of West Virginia  
 Department of Administration  
 Purchasing Division  
 2019 Washington Street East  
 Post Office Box 50130  
 Charleston, WV 25305-0130

# Request for Quotation

RFQ NUMBER  
**857C2059**

PAGE  
**1**

ADDRESS CORRESPONDENCE TO ATTENTION OF:  
**JOHN JOHNSTON**  
**304-558-2402**

\*618163839 877-335-4638  
 FILTRONA EXTRUSION  
 3110 70TH AVENUE EAST  
 TACOMA WA 98424

V  
E  
N  
D  
O  
R

S  
H  
I  
P  
T  
O

DIVISION OF HIGHWAYS  
 VARIOUS LOCALES AS INDICATED  
 BY ORDER

|                              |               |                          |             |               |
|------------------------------|---------------|--------------------------|-------------|---------------|
| DATE PRINTED                 | TERMS OF SALE | SHIP VIA                 | F.O.B.      | FREIGHT TERMS |
| 06/14/2007                   | NET 30        | Roadway or UPS           | Destination | Prepaid       |
| BID OPENING DATE: 07/03/2007 |               | BID OPENING TIME 01:30PM |             |               |

| LINE  | QUANTITY | UOP | CAT NO | ITEM NUMBER | UNIT PRICE | AMOUNT |
|---|----------|-----|--------|-------------|------------|--------|
| 0001  | 1        | EA  |        | 550-41      |            |        |
| TYPE 1 SOIL ANCHORED FLEXIBLE DELINEATOR POSTS<br>OPEN END CONTRACT<br>TO PROVIDE TYPE I SOIL ANCHORED FLEXIBLE DELINEATOR POSTS, ANCHORS, AND INSTALLATION HARDWARE TO THE WEST VIRGINIA DIVISION OF HIGHWAYS (WVDOT) AS PER THE ATTACHED SPECIFICATIONS.<br>EXHIBIT 3<br>LIFE OF CONTRACT: THIS CONTRACT BECOMES EFFECTIVE ON ..... AND EXTENDS FOR A PERIOD OF ONE (1) YEAR OR UNTIL SUCH "REASONABLE TIME" THEREAFTER AS IS NECESSARY TO OBTAIN A NEW CONTRACT OR RENEW THE ORIGINAL CONTRACT. THE "REASONABLE TIME" PERIOD SHALL NOT EXCEED TWELVE (12) MONTHS. DURING THIS "REASONABLE TIME" THE VENDOR MAY TERMINATE THIS CONTRACT FOR ANY REASON UPON GIVING THE DIRECTOR OF PURCHASING 30 DAYS WRITTEN NOTICE.<br>UNLESS SPECIFIC PROVISIONS ARE STIPULATED ELSEWHERE IN THIS CONTRACT DOCUMENT, THE TERMS, CONDITIONS AND PRICING SET HEREIN ARE FIRM FOR THE LIFE OF THE CONTRACT.<br>RENEWAL: THIS CONTRACT MAY BE RENEWED UPON THE MUTUAL WRITTEN CONSENT OF THE SPENDING UNIT AND VENDOR, SUBMITTED TO THE DIRECTOR OF PURCHASING THIRTY (30) DAYS PRIOR TO THE EXPIRATION DATE. SUCH RENEWAL SHALL BE IN ACCORDANCE WITH THE TERMS AND CONDITIONS OF THE ORIGINAL CONTRACT AND SHALL BE LIMITED TO TWO (2) ONE |          |     |        |             |            |        |

*See attached pgs.*

RECEIVED

2007 JUL -2 A 9:42

PURCHASING DIVISION  
 STATE OF WV

*[Signature]*

|   |              |                                   |  |
|---|--------------|-----------------------------------|--|
| SEE REVERSE SIDE FOR TERMS AND CONDITIONS |              |                                   |  |
| SIGNATURE                                 | TELEPHONE    | DATE                              |  |
| <i>[Signature]</i>                        | 253-284-8000 | 6/29/2007                         |  |
| TITLE                                     | FEIN         | ADDRESS CHANGES TO BE NOTED ABOVE |  |
| Vice President Sales                      | 91-1394310   |                                   |  |

WHEN RESPONDING TO RFQ, INSERT NAME AND ADDRESS IN SPACE ABOVE LABELED 'VENDOR'



State of West Virginia  
 Department of Administration  
 Purchasing Division  
 2019 Washington Street East  
 Post Office Box 50130  
 Charleston, WV 25305-0130

# Request for Quotation

RFQ NUMBER  
**857C2059**

PAGE  
**2**

ADDRESS CORRESPONDENCE TO ATTENTION OF  
**JOHN JOHNSTON  
 304-558-2402**

**\*618163839 877-335-4638**  
**FILTRONA EXTRUSION**  
**3110 70TH AVENUE EAST**  
**TACOMA WA 98424**

**DIVISION OF HIGHWAYS**  
**VARIOUS LOCALES AS INDICATED**  
**BY ORDER**

| DATE PRINTED                 | TERMS OF SALE | SHIP VIA                 | F.O.B       | FREIGHT TERMS |
|------------------------------|---------------|--------------------------|-------------|---------------|
| 06/14/2007                   | Net 30        | Roadway or UPS           | Destination | Prepaid       |
| BID OPENING DATE: 07/03/2007 |               | BID OPENING TIME 01:30PM |             |               |

| LINE  | QUANTITY | UOP | CAT. NO. | ITEM NUMBER | UNIT PRICE | AMOUNT |
|---|----------|-----|----------|-------------|------------|--------|
|   |          |     |          |             |            |        |
| <p>(1) YEAR PERIODS.</p> <p>CANCELLATION: THE DIRECTOR OF PURCHASING RESERVES THE RIGHT TO CANCEL THIS CONTRACT IMMEDIATELY UPON WRITTEN NOTICE TO THE VENDOR IF THE COMMODITIES AND/OR SERVICES SUPPLIED ARE OF AN INFERIOR QUALITY OR DO NOT CONFORM TO THE SPECIFICATIONS OF THE BID AND CONTRACT HEREIN.</p> <p>OPEN MARKET CLAUSE: THE DIRECTOR OF PURCHASING MAY AUTHORIZE A SPENDING UNIT TO PURCHASE ON THE OPEN MARKET, WITHOUT THE FILING OF A REQUISITION OR COST ESTIMATE, ITEMS SPECIFIED ON THIS CONTRACT FOR IMMEDIATE DELIVERY IN EMERGENCIES DUE TO UNFORESEEN CAUSES (INCLUDING BUT NOT LIMITED TO DELAYS IN TRANSPORTATION OR AN UNANTICIPATED INCREASE IN THE VOLUME OF WORK.)</p> <p>QUANTITIES: QUANTITIES LISTED IN THE REQUISITION ARE APPROXIMATIONS ONLY, BASED ON ESTIMATES SUPPLIED BY THE STATE SPENDING UNIT. IT IS UNDERSTOOD AND AGREED THAT THE CONTRACT SHALL COVER THE QUANTITIES ACTUALLY ORDERED FOR DELIVERY DURING THE TERM OF THE CONTRACT, WHETHER MORE OR LESS THAN THE QUANTITIES SHOWN.</p> <p>ORDERING PROCEDURE: SPENDING UNIT(S) SHALL ISSUE A WRITTEN STATE CONTRACT ORDER (FORM NUMBER WV-39) TO THE VENDOR FOR COMMODITIES COVERED BY THIS CONTRACT. THE ORIGINAL COPY OF THE WV-39 SHALL BE MAILED TO THE VENDOR AS AUTHORIZATION FOR SHIPMENT, A SECOND COPY MAILED TO THE PURCHASING DIVISION, AND A THIRD COPY RETAINED BY THE SPENDING UNIT.</p> <p>BANKRUPTCY: IN THE EVENT THE VENDOR/CONTRACTOR FILES FOR BANKRUPTCY PROTECTION, THIS CONTRACT IS AUTOMATICALLY NULL AND VOID, AND IS TERMINATED WITHOUT FURTHER ORDER.</p> |          |     |          |             |            |        |

*[Handwritten Signature]*

|   |              |                                   |  |
|---|--------------|-----------------------------------|--|
| SEE REVERSE SIDE FOR TERMS AND CONDITIONS |              |                                   |  |
| SIGNATURE                                 | TELEPHONE    | DATE                              |  |
| <i>[Signature]</i>                        | 253-284-8000 | 6/29/2007                         |  |
| TITLE                                     | FEIN         | ADDRESS CHANGES TO BE NOTED ABOVE |  |
| Vice President Sales                      | 91-1394310   |                                   |  |

WHEN RESPONDING TO RFQ, INSERT NAME AND ADDRESS IN SPACE ABOVE LABELED 'VENDOR'



State of West Virginia  
 Department of Administration  
 Purchasing Division  
 2019 Washington Street East  
 Post Office Box 50130  
 Charleston, WV 25305-0130

# Request for Quotation

RFQ NUMBER  
**857C2059**

PAGE  
**3**

ADDRESS CORRESPONDENCE TO ATTENTION OF:  
**JOHN JOHNSTON**  
**304-558-2402**

VENDOR

\*618163839      877-335-4638  
**FILTRONA EXTRUSION**  
**3110 70TH AVENUE EAST**  
  
**TACOMA WA 98424**

SHIP TO

**DIVISION OF HIGHWAYS**  
**VARIOUS LOCALES AS INDICATED**  
**BY ORDER**

|                                     |                                |                                   |                              |                                 |
|-------------------------------------|--------------------------------|-----------------------------------|------------------------------|---------------------------------|
| DATE PRINTED<br><b>06/14/2007</b>   | TERMS OF SALE<br><b>Net 30</b> | SHIP VIA<br><b>Roadway or UPS</b> | F.O.B.<br><b>Destination</b> | FREIGHT TERMS<br><b>Prepaid</b> |
| BID OPENING DATE: <b>07/03/2007</b> |                                | BID OPENING TIME <b>01:30PM</b>   |                              |                                 |

| LINE  | QUANTITY | UOP | CAT. NO. | ITEM NUMBER | UNIT PRICE | AMOUNT |
|---|----------|-----|----------|-------------|------------|--------|
| <p>THE TERMS AND CONDITIONS CONTAINED IN THIS CONTRACT SHALL SUPERSEDE ANY AND ALL SUBSEQUENT TERMS AND CONDITIONS WHICH MAY APPEAR ON ANY ATTACHED PRINTED DOCUMENTS SUCH AS PRICE LISTS, ORDER FORMS, SALES AGREEMENTS OR MAINTENANCE AGREEMENTS, INCLUDING ANY ELECTRONIC MEDIUM SUCH AS CD-ROM.</p> <p>REV. 04/11/2001</p> <p>PURCHASING CARD ACCEPTANCE: THE STATE OF WEST VIRGINIA CURRENTLY UTILIZES A VISA PURCHASING CARD PROGRAM WHICH IS ISSUED THROUGH A BANK. THE SUCCESSFUL VENDOR MUST ACCEPT THE STATE OF WEST VIRGINIA VISA PURCHASING CARD FOR PAYMENT OF ALL ORDERS PLACED BY ANY STATE AGENCY FOR ORDERS THAT ARE LESS THAN \$2,500 AS A CONDITION OF AWARD.</p> <p style="text-align: center;">VENDOR PREFERENCE CERTIFICATE</p> <p>CERTIFICATION AND APPLICATION* IS HEREBY MADE FOR PREFERENCE IN ACCORDANCE WITH WEST VIRGINIA CODE, 5A-3-37 (DOES NOT APPLY TO CONSTRUCTION CONTRACTS).</p> <p>A. APPLICATION IS MADE FOR 2.5% PREFERENCE FOR THE REASON CHECKED:</p> <p>( ) BIDDER IS AN INDIVIDUAL RESIDENT VENDOR AND HAS RESIDED CONTINUOUSLY IN WEST VIRGINIA FOR FOUR (4) YEARS IMMEDIATELY PRECEDING THE DATE OF THIS CERTIFICATION; OR</p> <p>( ) BIDDER IS A PARTNERSHIP, ASSOCIATION OR CORPORATION RESIDENT VENDOR AND HAS MAINTAINED ITS HEAD-QUARTERS OR PRINCIPAL PLACE OF BUSINESS CONTINUOUSLY IN WEST VIRGINIA FOR FOUR (4) YEARS IMMEDIATELY PRECEDING</p> |          |     |          |             |            |        |

SEE REVERSE SIDE FOR TERMS AND CONDITIONS

|                                      |                                  |                                   |
|--------------------------------------|----------------------------------|-----------------------------------|
| SIGNATURE<br>                        | TELEPHONE<br><b>253-284-8000</b> | DATE<br><b>6/29/2007</b>          |
| TITLE<br><b>Vice President Sales</b> | FEIN<br><b>91-1394310</b>        | ADDRESS CHANGES TO BE NOTED ABOVE |

WHEN RESPONDING TO RFQ, INSERT NAME AND ADDRESS IN SPACE ABOVE LABELED 'VENDOR'



State of West Virginia  
 Department of Administration  
 Purchasing Division  
 2019 Washington Street East  
 Post Office Box 50130  
 Charleston, WV 25305-0130

# Request for Quotation

RFQ NUMBER  
**857C2059**

PAGE  
**4**

ADDRESS CORRESPONDENCE TO ATTENTION OF:  
**JOHN JOHNSTON  
 304-558-2402**

VENDOR

\*618163839      877-335-4638  
**FILTRONA EXTRUSION**  
**3110 70TH AVENUE EAST**  
  
**TACOMA WA 98424**

SHIP TO

**DIVISION OF HIGHWAYS**  
**VARIOUS LOCALES AS INDICATED**  
**BY ORDER**

|                              |               |                          |             |               |
|------------------------------|---------------|--------------------------|-------------|---------------|
| DATE PRINTED                 | TERMS OF SALE | SHIP VIA                 | F.O.B       | FREIGHT TERMS |
| 06/14/2007                   | Net 30        | Roadway or UPS           | Destination | Prepaid       |
| BID OPENING DATE: 07/03/2007 |               | BID OPENING TIME 01:30PM |             |               |

| LINE  | QUANTITY | UOP | CAT NO | ITEM NUMBER | UNIT PRICE | AMOUNT |
|---|----------|-----|--------|-------------|------------|--------|
| <p>THE DATE OF THIS CERTIFICATION; OR 80% OF THE OWNERSHIP INTEREST OF BIDDER IS HELD BY ANOTHER INDIVIDUAL, PARTNERSHIP, ASSOCIATION OR CORPORATION RESIDENT VENDOR WHO HAS MAINTAINED ITS HEADQUARTERS OR PRINCIPAL PLACE OF BUSINESS CONTINUOUSLY IN WEST VIRGINIA FOR FOUR (4) YEARS IMMEDIATELY PRECEDING THE DATE OF THIS CERTIFICATION; OR</p> <p>( ) BIDDER IS A CORPORATION NONRESIDENT VENDOR WHICH HAS AN AFFILIATE OR SUBSIDIARY WHICH EMPLOYS A MINIMUM OF ONE HUNDRED STATE RESIDENTS AND WHICH HAS MAINTAINED ITS HEADQUARTERS OR PRINCIPAL PLACE OF BUSINESS WITHIN WEST VIRGINIA CONTINUOUSLY FOR THE FOUR (4) YEARS IMMEDIATELY PRECEDING THE DATE OF THIS CERTIFICATION.</p> <p>B. APPLICATION IS MADE FOR 2.5% PREFERENCE FOR THE REASON CHECKED:</p> <p>( ) BIDDER IS A RESIDENT VENDOR WHO CERTIFIES THAT, DURING THE LIFE OF THE CONTRACT, ON AVERAGE AT LEAST 75% OF THE EMPLOYEES WORKING ON THE PROJECT BEING BID ARE RESIDENTS OF WEST VIRGINIA WHO HAVE RESIDED IN THE STATE CONTINUOUSLY FOR THE TWO YEARS IMMEDIATELY PRECEDING SUBMISSION OF THIS BID;</p> <p>OR</p> <p>( ) BIDDER IS A NONRESIDENT VENDOR EMPLOYING A MINIMUM OF ONE HUNDRED STATE RESIDENTS OR IS A NONRESIDENT VENDOR WITH AN AFFILIATE OR SUBSIDIARY WHICH MAINTAINS ITS HEADQUARTERS OR PRINCIPAL PLACE OF BUSINESS WITHIN WEST VIRGINIA EMPLOYING A MINIMUM OF ONE HUNDRED STATE RESIDENTS WHO CERTIFIES THAT, DURING THE LIFE OF THE CONTRACT, ON AVERAGE AT LEAST 75% OF THE EMPLOYEES OR BIDDERS' AFFILIATE'S OR SUBSIDIARY'S EMPLOYEES ARE RESIDENTS OF WEST VIRGINIA WHO HAVE RESIDED IN THE STATE CONTINUOUSLY FOR THE TWO</p> |          |     |        |             |            |        |

SEE REVERSE SIDE FOR TERMS AND CONDITIONS

SIGNATURE: TELEPHONE: 253-284-8000 DATE: 6/29/2007

TITLE: Vice President Sales FEIN: 91-1394310 ADDRESS CHANGES TO BE NOTED ABOVE

WHEN RESPONDING TO RFQ, INSERT NAME AND ADDRESS IN SPACE ABOVE LABELED 'VENDOR'



State of West Virginia  
 Department of Administration  
 Purchasing Division  
 2019 Washington Street East  
 Post Office Box 50130  
 Charleston, WV 25305-0130

# Request for Quotation

RFQ NUMBER  
**857C2059**

PAGE  
**5**

ADDRESS CORRESPONDENCE TO ATTENTION OF  
**JOHN JOHNSTON.  
 304-558-2402**

VENDOR

\*618163839      877-335-4638  
**FILTRONA EXTRUSION**  
**3110 70TH AVENUE EAST**  
  
**TACOMA WA 98424**

SHIP TO

**DIVISION OF HIGHWAYS**  
**VARIOUS LOCALES AS INDICATED**  
**BY ORDER**

|  |                                |                                    |                              |                                 |
|--|--------------------------------|------------------------------------|------------------------------|---------------------------------|
| DATE PRINTED<br><b>06/14/2007</b>      | TERMS OF SALE<br><b>Net 30</b> | SHIP VIA<br><b>Roadway or UPS</b>  | F.O.B.<br><b>Destination</b> | FREIGHT TERMS<br><b>Prepaid</b> |
| BID OPENING DATE:<br><b>07/03/2007</b> |                                | BID OPENING TIME<br><b>01:30PM</b> |                              |                                 |

| LINE   | QUANTITY | UOP | CAT NO. | ITEM NUMBER | UNIT PRICE | AMOUNT |
|--|----------|-----|---------|-------------|------------|--------|
| <p>YEARS IMMEDIATELY PRECEDING SUBMISSION OF THIS BID.</p> <p>BIDDER UNDERSTANDS IF THE SECRETARY OF TAX &amp; REVENUE DETERMINES THAT A BIDDER RECEIVING PREFERENCE HAS FAILED TO CONTINUE TO MEET THE REQUIREMENTS FOR SUCH PREFERENCE, THE SECRETARY MAY ORDER THE DIRECTOR OF PURCHASING TO: (A) RESCIND THE CONTRACT OR PURCHASE ORDER ISSUED; OR (B) ASSESS A PENALTY AGAINST SUCH BIDDER IN AN AMOUNT NOT TO EXCEED 5% OF THE BID AMOUNT AND THAT SUCH PENALTY WILL BE PAID TO THE CONTRACTING AGENCY OR DEDUCTED FROM ANY UNPAID BALANCE ON THE CONTRACT OR PURCHASE ORDER.</p> <p>BY SUBMISSION OF THIS CERTIFICATE, BIDDER AGREES TO DISCLOSE ANY REASONABLY REQUESTED INFORMATION TO THE PURCHASING DIVISION AND AUTHORIZES THE DEPARTMENT OF TAX AND REVENUE TO DISCLOSE TO THE DIRECTOR OF PURCHASING APPROPRIATE INFORMATION VERIFYING THAT BIDDER HAS PAID THE REQUIRED BUSINESS TAXES, PROVIDED THAT SUCH INFORMATION DOES NOT CONTAIN THE AMOUNTS OF TAXES PAID NOR ANY OTHER INFORMATION DEEMED BY THE TAX COMMISSIONER TO BE CONFIDENTIAL.</p> <p>UNDER PENALTY OF LAW FOR FALSE SWEARING (WEST VIRGINIA CODE 61-5-3), BIDDER HEREBY CERTIFIES THAT THIS CERTIFICATE IS TRUE AND ACCURATE IN ALL RESPECTS; AND THAT IF A CONTRACT IS ISSUED TO BIDDER AND IF ANYTHING CONTAINED WITHIN THIS CERTIFICATE CHANGES DURING THE TERM OF THE CONTRACT, BIDDER WILL NOTIFY THE PURCHASING DIVISION IN WRITING IMMEDIATELY.</p> <p>BIDDER: <u>Filtrona Extrusion Inc.</u></p> <p>DATE: <u>6/29/2007</u></p> |          |     |         |             |            |        |

|   |                                  |                                   |  |
|---|----------------------------------|-----------------------------------|--|
| SEE REVERSE SIDE FOR TERMS AND CONDITIONS |                                  |                                   |  |
| SIGNATURE<br>                             | TELEPHONE<br><b>253-284-8000</b> | DATE<br><b>6/29/2007</b>          |  |
| TITLE<br><b>Vice President Sales</b>      | FEIN<br><b>91-1394310</b>        | ADDRESS CHANGES TO BE NOTED ABOVE |  |

WHEN RESPONDING TO RFQ, INSERT NAME AND ADDRESS IN SPACE ABOVE LABELED 'VENDOR'



State of West Virginia  
 Department of Administration  
 Purchasing Division  
 2019 Washington Street East  
 Post Office Box 50130  
 Charleston, WV 25305-0130

# Request for Quotation

RFQ NUMBER  
**857C2059**

PAGE  
**6**

ADDRESS CORRESPONDENCE TO ATTENTION OF:  
**JOHN JOHNSTON**  
**304-558-2402**

VENDOR

\*618163839      877-335-4638  
 FILTRONA EXTRUSION  
 3110 70TH AVENUE EAST  
 TACOMA WA 98424

SHIP TO

DIVISION OF HIGHWAYS  
 VARIOUS LOCALES AS INDICATED  
 BY ORDER

| DATE PRINTED                 | TERMS OF SALE | SHIP VIA                 | FOB         | FREIGHT TERMS |
|------------------------------|---------------|--------------------------|-------------|---------------|
| 06/14/2007                   | Net 30        | Roadway or UPS           | Destination | Prepaid       |
| BID OPENING DATE: 07/03/2007 |               | BID OPENING TIME 01:30PM |             |               |

| LINE   | QUANTITY | UOP | CAT NO. | ITEM NUMBER | UNIT PRICE | AMOUNT |
|--|----------|-----|---------|-------------|------------|--------|
| <p>SIGNED: <i>[Signature]</i></p> <p>TITLE: <i>Vice President Sales</i></p> <p>* CHECK ANY COMBINATION OF PREFERENCE CONSIDERATION(S) IN EITHER "A" OR "B", OR BOTH "A" AND "B" WHICH YOU ARE ENTITLED TO RECEIVE. YOU MAY REQUEST UP TO THE MAXIMUM 5% PREFERENCE FOR BOTH "A" AND "B". (REV. 12/00)</p> <p>NOTICE</p> <p>A SIGNED BID MUST BE SUBMITTED TO:</p> <p>DEPARTMENT OF ADMINISTRATION<br/>         PURCHASING DIVISION<br/>         BUILDING 15<br/>         2019 WASHINGTON STREET, EAST<br/>         CHARLESTON, WV 25305-0130</p> <p>THE BID SHOULD CONTAIN THIS INFORMATION ON THE FACE OF THE ENVELOPE OR THE BID MAY NOT BE CONSIDERED:</p> <p>SEALED BID</p> <p>BUYER: 33</p> <p>RFQ. NO.: 857C2059</p> |          |     |         |             |            |        |

SEE REVERSE SIDE FOR TERMS AND CONDITIONS

|                                 |                           |                                   |
|---------------------------------|---------------------------|-----------------------------------|
| SIGNATURE<br><i>[Signature]</i> | TELEPHONE<br>253-284-8000 | DATE<br>6/29/2007                 |
| TITLE<br>Vice President Sales   | FEIN<br>91-1394310        | ADDRESS CHANGES TO BE NOTED ABOVE |

WHEN RESPONDING TO RFQ, INSERT NAME AND ADDRESS IN SPACE ABOVE LABELED 'VENDOR'



State of West Virginia  
 Department of Administration  
 Purchasing Division  
 2019 Washington Street East  
 Post Office Box 50130  
 Charleston, WV 25305-0130

# Request for Quotation

|            |
|------------|
| RFO NUMBER |
| 857C2059   |

|      |
|------|
| PAGE |
| 7    |

|   |
|---|
| ADDRESS CORRESPONDENCE TO ATTENTION OF: |
| JOHN JOHNSTON<br>304-558-2402           |

VENDOR

\*618163839      877-335-4638  
 FILTRONA EXTRUSION  
 3110 70TH AVENUE EAST  
 TACOMA WA 98424

SHIP TO

DIVISION OF HIGHWAYS  
 VARIOUS LOCALES AS INDICATED  
 BY ORDER

|                              |               |                          |             |               |
|------------------------------|---------------|--------------------------|-------------|---------------|
| DATE PRINTED                 | TERMS OF SALE | SHIP VIA                 | F.O.B       | FREIGHT TERMS |
| 06/14/2007                   | Net 30        | Roadway or UPS           | Destination | Prepaid       |
| BID OPENING DATE: 07/03/2007 |               | BID OPENING TIME 01:30PM |             |               |

| LINE   | QUANTITY | UOP | CAT. NO. | ITEM NUMBER | UNIT PRICE | AMOUNT      |
|--|----------|-----|----------|-------------|------------|-------------|
| BID OPENING DATE AND TIME  |          |     |          |             |            |             |
| PLEASE PROVIDE A FAX NUMBER IN CASE IT IS NECESSARY TO CONTACT YOU REGARDING YOUR BID:<br>253-284-8080 |          |     |          |             |            |             |
| CONTACT PERSON (PLEASE PRINT CLEARLY):<br>Peter Speer  |          |     |          |             |            |             |
| ***** THIS IS THE END OF RFQ 857C2059 ***** TOTAL:   |          |     |          |             |            | \$18,907.16 |

|   |                           |                                   |
|---|---------------------------|-----------------------------------|
| SEE REVERSE SIDE FOR TERMS AND CONDITIONS |                           |                                   |
| SIGNATURE<br>                             | TELEPHONE<br>253-284-8000 | DATE<br>6/29/2007                 |
| TITLE<br>Vice President Sales             | FEIN<br>91-1394310        | ADDRESS CHANGES TO BE NOTED ABOVE |

WHEN RESPONDING TO RFQ, INSERT NAME AND ADDRESS IN SPACE ABOVE LABELED 'VENDOR'

## Type I Soil Anchored Flexible Delineator Posts

### SCOPE OF CONTRACT

To provide Type I Soil Anchored Flexible Delineator Posts, anchors, and installation hardware.

### MATERIAL SPECIFICATIONS

Type I Soil Anchored Flexible Delineator Posts shall be manufactured using polymer materials such as polyethylene or engineered thermoplastics, and shall be manufactured to be resistant to impact as well as deterioration and fading from UV light exposure. Type I Soil Anchored Flexible Delineator Posts shall be designed to yield when impacted from the front or back, and to subsequently return to their original upright position.

Type I Soil Anchored Flexible Delineator Posts shall be manufactured and supplied white or yellow, as specified. Type I Soil Anchored Flexible Delineator Posts shall be manufactured to a minimum of 54" in length and 4" in width, with the ability to accommodate, front and back, a 3" wide by 9" tall piece of Type ASTM-IX fluorescent-yellow, white, or red High Performance Grade sheeting of the color specified, with the bottom edge of the sheeting no less than 43" from the bottom of the post. The posts shall be flat or nearly flat at the reflective portion of the post, and of a constant cross-section at the reflective portion of the post. Type I Soil Anchored Flexible Delineator Posts shall be U-channel anchored posts, and shall utilize an 18" length piece of u-channel weighing no less than 1.12 pounds per foot. U-channel anchors shall meet the u-channel requirements of the WVDOH Standard Specifications, and shall be galvanized in accordance to ASTM Specification A123. Attachment hardware shall be of the size and length recommended and supplied by the manufacturer and shall be manufactured of stainless, zinc plated, or galvanized steel.

### APPROVED PRODUCTS

Posts bid by vendors shall be a model post off of the current Approved Product List (APL). Approvals of Type I Soil Anchored Flexible Delineator Posts are based on results from NTPEP and/or WVDOH testing and demonstration projects. The Division reserves the right to remove products from the APL based on actual field performance.

The current APL for Type I Soil Anchored Flexible Delineator is as follows:

| MANUFACTURER      | PRODUCT     | MODEL NUMBER |
|-------------------|-------------|--------------|
| Carsonite         | Survivor    | CDS30        |
| Carsonite         | Greenline   | CGDU         |
| Davidson Plastics | Flexi-Guide | FG-500       |



Approved Type ASTM-IX sheetings applicable to this Contract are as follows:

| <b><u>TYPE ASTM-IX - HIGH PERFORMANCE GRADE</u></b>  |                                      |
|--|--------------------------------------|
| <b><u>MANUFACTURER</u></b>   | <b><u>PRODUCT</u></b>                |
| 3M   | Scotchlite 3981 Series (See note 12) |
| 3M   | Scotchlite 399X Series (See note 14) |
| 12 - Fluorescent yellow pressure sensitive sheeting for use with soil anchored or guardrail mounted flexible delineators, B1 delineators, and aluminum substrate signs                                       |                                      |
| 14 - Various colored pressure sensitive sheetings for use with soil anchored or guardrail mounted flexible delineators (white or red only), B1 delineators (white or red only), and aluminum substrate signs |                                      |

The item supplied under Bid Item 14 shall be a Carsonite DSD300, Filtrona Extrusion FG103, or approved equal manual driving tool for u-channel delineator anchors.

### **BID ITEMS**

Type I Soil Anchored Flexible Delineator Posts shall be bid complete. Complete units are to include post, Type ASTM-IX fluorescent-yellow, white, and/or red High Performance Grade retroreflective sheeting (applied as specified), u-channel anchor, and all associated hardware necessary to attach the post to the anchor. Posts and anchors shall also be available for purchase separately as part of this contract. Posts will always be required to have a minimum of one 3" x 9" vertical strip of Type ASTM-IX white or fluorescent-yellow High Performance Grade retroreflective sheeting on the front face of the post. If the post is ordered as 2-way reflective, an additional 3" x 9" vertical strip of like color, or Type ASTM-IX red High Performance Grade retroreflective sheeting, if specified, shall be required on the back side of the flat upper portion of the post. Posts and anchors shall also be available for purchase separately as part of this contract. Orders for posts only shall include the required hardware to attach the post to the anchor.

### **MINIMUM ORDER**

A minimum order shall consist of no less than 25 units per item number to a particular destination for Item numbers 1 through 13.

### **DELIVERY**

All prices bid shall be FOB destination in accordance with the list of delivery destinations made a part of this contract. All orders shall be shipped complete within forty-five (45) days A.R.O. Late delivery charges against the vendor may be assessed at a rate of \$50.00 per calendar day after forty-five (45) days ARO. Notification of shipment from vendor shall be received a minimum of 48 hours before delivery of material at the location indicated on the release.

**BID SCHEDULE**

The following estimated quantities are for bid purposes only. Actual quantities will be determined by needs of the West Virginia Division of Highways and may be increased or decreased.

| Item Number   | Estimated Quantity | Description   | Unit Cost | Total Cost | Inventory Subcode (DOH Use Only) (Class 019 Type 008) |
|---|--------------------|---|-----------|------------|---|
| <b>Type I Soil Anchored Flexible Delineator Posts</b>                           |                    |   |           |            |   |
| <b>MANUFACTURER &amp; MODEL POST BD: <i>Filtroa - Davidson Fg500 Series</i></b> |                    |   |           |            |   |
| 1   | 700                | Per each, <b>Complete</b> Type I Soil Anchored Flexible Delineator Post, White, 1-way reflective <b>white</b> , To include post, retroreflective sheeting (applied), soil anchor, and post attachment hardware                  | \$ 11.09  | \$ 7763.00 | 080631  |
| 2   | 100                | Per each, <b>Complete</b> Type I Soil Anchored Flexible Delineator Post, White, 2-way reflective <b>white/white</b> , To include post, retroreflective sheeting (applied), soil anchor, and post attachment hardware            | \$ 12.88  | \$ 1288.00 | 080632  |
| 3   | 100                | Per each, <b>Complete</b> Type I Soil Anchored Flexible Delineator Post, White, 2-way reflective <b>white/red</b> , To include post, retroreflective sheeting (applied), soil anchor, and post attachment hardware              | \$ 13.33  | \$ 1333.00 | 080632  |
| 4   | 300                | Per each, <b>Complete</b> Type I Soil Anchored Flexible Delineator Post, Yellow, 1-way reflective <b>fl. yellow</b> , To include post, retroreflective sheeting (applied), soil anchor, and post attachment hardware            | \$ 11.42  | \$ 3426.00 | 080633  |
| 5   | 50                 | Per each, <b>Complete</b> Type I Soil Anchored Flexible Delineator Post, Yellow, 2-way reflective <b>fl. yellow/fl. yellow</b> , To include post, retroreflective sheeting (applied), soil anchor, and post attachment hardware | \$ 13.55  | \$ 677.50  | 080634  |
| 6   | 50                 | Per each, <b>Complete</b> Type I Soil Anchored Flexible Delineator Post, Yellow, 2-way reflective <b>fl. yellow/red</b> , To include post, retroreflective sheeting (applied), soil anchor, and post attachment hardware        | \$ 13.67  | \$ 683.50  | 080634  |
| 7   | 175                | Per each, <b>Replacement</b> Type I Soil Anchored Flexible Delineator Post, White, 1-way reflective <b>white</b> , To include post, retroreflective sheeting (applied), and post attachment hardware                            | \$ 8.40   | \$ 1470.00 | 080635  |
| 8   | 25                 | Per each, <b>Replacement</b> Type I Soil Anchored Flexible Delineator Post, White, 2-way reflective <b>white/white</b> , To include post, retroreflective sheeting (applied), and post attachment hardware                      | \$ 10.20  | \$ 255.00  | 080636  |
| 9   | 25                 | Per each, <b>Replacement</b> Type I Soil Anchored Flexible Delineator Post, White, 2-way reflective <b>white/red</b> , To include post, retroreflective sheeting (applied), and post attachment hardware                        | \$ 10.65  | \$ 266.25  | 080636  |
| 10  | 75                 | Per each, <b>Replacement</b> Type I Soil Anchored Flexible Delineator Post, Yellow, 1-way reflective <b>fl. yellow</b> , To include post, retroreflective sheeting (applied), and post attachment hardware                      | \$ 8.73   | \$ 654.75  | 080637  |

| Item Number           | Estimated Quantity | Description   | Unit Cost | Total Cost  | Inventory Subcode (DOH Use Only) (Class 019 Type 008) |
|-----------------------|--------------------|---|-----------|-------------|---|
| 11                    | 10                 | Per each, Replacement Type I Soil Anchored Flexible Delineator Post, Yellow, 2-way reflective fl. yellow/ fl. yellow, To include post, retroreflective sheeting (applied), and post attachment hardware | \$10.86   | \$108.60    | 080638  |
| 12                    | 10                 | Per each, Replacement Type I Soil Anchored Flexible Delineator Post, Yellow, 2-way reflective fl. yellow/red, To include post, retroreflective sheeting (applied), and post attachment hardware         | \$10.98   | \$109.80    | 080638  |
| 13                    | 150                | Per each, Replacement U-Channel anchor  | \$2.34    | \$351.00    | 080639  |
| <b>ACCESSORIES</b>    |                    |   |           |             |   |
| 14                    | 1                  | Per each, Manual Driving Tool<br><b>MANUFACTURER &amp; MODEL BID: Filtrona-Davidson Fg103</b>   |           |             | 080328  |
| 15                    | 1                  | Per each, Anchor Mechanical Driving Tool, to include Driving Head and 4-1/4" x 7/8" Shank, for use with Atlas Copco Pioneer   | \$76.36   | \$76.36     | 080442  |
| 16                    | 1                  | Per each, Anchor Mechanical Driving Tool, to include Driving Head and 6" x 1-1/4" Shank, for use with Skidril BG231 and Atlas Copco Cobra MK-1 or FB-60   | \$444.40  | \$444.40    | 080441  |
| <b>CONTRACT TOTAL</b> |                    |   | →         | \$18,907.16 |   |

**CONTACT PERSON AND DELIVERY ADDRESS FOR EACH  
DIVISION OF HIGHWAYS DESTINATION**

| <b>Delivery Address</b>   | <b>Contact</b>                  | <b>Phone Number</b>           |
|---|---------------------------------|-------------------------------|
| WVDOH - D1 Sign Shop<br>75 Pickens Rd.<br>Nitro, WV 25143   | Jim Russell                     | 304-759-0708<br>304-558-3001* |
| WVDOH - D2 Sign Shop<br>801 Madison Ave.<br>Huntington, WV 25704  | Ed Layman                       | 304-528-5679<br>304-528-5600* |
| WVDOH - D3 Sign Shop<br>720 Depot St.<br>Parkersburg, WV 26101  | Tom Potts                       | 304-420-4815<br>304-420-4645* |
| WVDOH - D4 Sign Shop<br>US-19 - 1 mile N. of Clarksburg (gore yard)<br>Clarksburg, WV 26301                         | Rick Reed                       | 304-627-2401<br>304-842-1500* |
| WVDOH - D5 Sign Shop<br>US-50 - 14 miles E. of Keyser<br>Burlington, WV 26710                                       | Doug Placka                     | 304-289-3521<br>304-289-3521* |
| WVDOH - D6 Sign Shop<br>US-40 - E. of Wheeling<br>(Middle Creek Rd. 39)<br>Triadelphia, WV 26059                    | Jim Wurtzbacher                 | 304-238-1205<br>304-238-4008* |
| WVDOH - D7 Sign Shop<br>US-33 - 1/2 mile E. of Weston<br>Weston, WV 26452   | Tyrone Campbell                 | 304-269-0460<br>304-269-0414* |
| WVDOH - D8 Sign Shop<br>Rt. 219 - 1 mile N. of Elkins<br>Elkins, WV 26241   | Mike Westfall                   | 304-637-0215<br>304-637-0220* |
| WVDOH - D9 Sign Shop<br>US-219 - 1-1/2 miles N. of Lewisburg<br>Country Club Rd. - Brush Rd.<br>Lewisburg, WV 24901 | Harry Honaker                   | 304-647-7551<br>304-647-7450* |
| WVDOH - D10 Sign Shop<br>270 Hardwood Lane<br>Princeton, WV 24740   | Curtis Whitlow                  | 304-487-5283<br>304-487-5228* |
| WVDOH - Traffic Services Complex<br>180 Dry Branch Rd.<br>Charleston, WV 25306                                      | Richard Rawling<br>Ted Whitmore | 304-558-6356<br>304-558-9468  |

\* District/Division headquarters phone number

STATE OF WEST VIRGINIA  
Purchasing Division

## PURCHASING AFFIDAVIT

**West Virginia Code §5A-3-10a states:** No contract or renewal of any contract may be awarded by the state or any of its political subdivisions to any vendor or prospective vendor when the vendor or prospective vendor or a related party to the vendor or prospective vendor is a debtor and the debt owned is an amount greater than one thousand dollars in the aggregate

### DEFINITIONS:

"Debt" means any assessment, premium, penalty, fine, tax or other amount of money owed to the state or any of its political subdivisions because of a judgment, fine, permit violation, license assessment, defaulted workers' compensation premium, penalty or other assessment presently delinquent or due and required to be paid to the state or any of its political subdivisions, including any interest or additional penalties accrued thereon.

"Debtor" means any individual, corporation, partnership, association, limited liability company or any other form or business association owing a debt to the state or any of its political subdivisions. "Political subdivision" means any county commission; municipality; county board of education; any instrumentality established by a county or municipality; any separate corporation or instrumentality established by one or more counties or municipalities, as permitted by law; or any public body charged by law with the performance of a government function or whose jurisdiction is coextensive with one or more counties or municipalities. "Related party" means a party, whether an individual, corporation, partnership, association, limited liability company or any other form or business association or other entity whatsoever, related to any vendor by blood, marriage, ownership or contract through which the party has a relationship of ownership or other interest with the vendor so that the party will actually or by effect receive or control a portion of the benefit, profit or other consideration from performance of a vendor contract with the party receiving an amount that meets or exceeds five percent of the total contract amount.

**EXCEPTION:** The prohibition of this section does not apply where a vendor has contested any tax administered pursuant to chapter eleven of this code, workers' compensation premium, permit fee or environmental fee or assessment and the matter has not become final or where the vendor has entered into a payment plan or agreement and the vendor is not in default of any of the provisions of such plan or agreement.

**LICENSING:** Vendors must be licensed and in good standing in accordance with any and all state and local laws and requirements by any state or local agency of West Virginia, including, but not limited to, the West Virginia Secretary of State's Office, the West Virginia Tax Department, West Virginia Insurance Commission, or any other state agencies or political subdivision. Furthermore, the vendor must provide all necessary releases to obtain information to enable the Director or spending unit to verify that the vendor is licensed and in good standing with the above entities.

**CONFIDENTIALITY:** The vendor agrees that he or she will not disclose to anyone, directly or indirectly, any such personally identifiable information or other confidential information gained from the agency, unless the individual who is the subject of the information consents to the disclosure in writing or the disclosure is made pursuant to the agency's policies, procedures and rules. Vendors should visit [www.state.wv.us/admin/purchase/privacy](http://www.state.wv.us/admin/purchase/privacy) for the Notice of Agency Confidentiality Policies.

Under penalty of law for false swearing (West Virginia Code, §61-5-3), it is hereby certified that the vendor acknowledges the information in this said affidavit and are in compliance with the requirements as stated.

Vendor's Name: Filtrona Extrusion Inc.

Authorized Signature: \_\_\_\_\_

Date: 6/29/2007

Davidson Traffic Control Products

## Available Options for Flexi-Guide® 400/500 Series

Flexible Roadside Delineator Posts

### FG Highway Delineator Posts

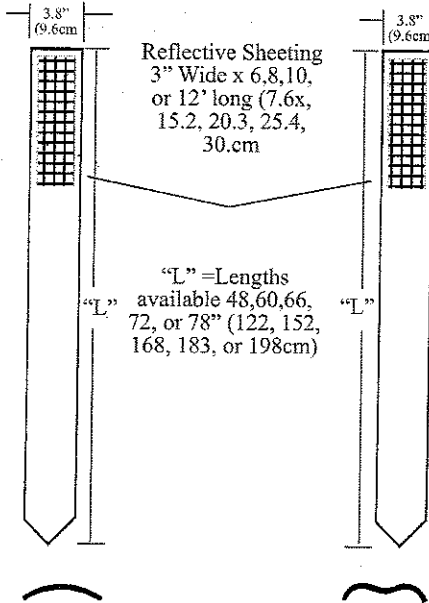

**FG 500 series**

**FG 400 series**

**Flexi-Guide Posts** - are available with a number of standard and special options, including reflective sheeting, message decals, custom colors and length, and various anchors

**Reflective Sheeting** - Flexi-Guide® posts may be ordered with factory-applied Engineer Grade, High-Intensity or Prismatic Super High Intensity retro-reflective sheeting. Specify type, color, and size when ordering.

**Message Decals** - Flexi-Guide® posts may be ordered with factory-applied Message Decals, such as "Buried Cable - Do Not Dig!" Call for details regarding availability of standard decal and custom print options.

**Custom Colors and Lengths** - Standard Flexi-Guide® colors are White, Yellow, and Grey. Other colors are available on a special order basis. Flexi-Guide® Posts can be cut to any length you desire.

**Anchors** - Flexi-Guide® posts may be supplied with or without plastic or steel anchors. If anchors are required, specify either plastic or steel when ordering.

### Flexi-Guide Anchors

FG 95  
Plastic Anchor  
all purpose

FG 96  
Steel Anchor  
for more  
challenging  
soils

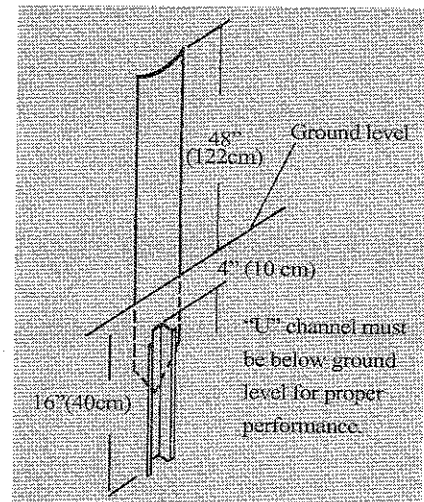
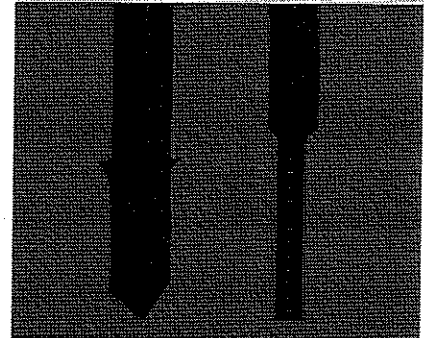

# Specifications for Flexi-Guide® 400/500 series

Flexible Roadside Delineator Posts



**GENERAL:** Flexible delineator posts shall be produced from recycled engineering thermo plastics.

**CONSTRUCTION:** All delineator posts shall be manufactured in the U.S.A. The post shall be made with a minimum of 5% post-consumer, engineered recycled thermoplastic, with the total recycled content being greater than 50%. Post will be modified with virgin modifiers, pigments and UV stabilizers for outdoor weatherability. Posts shall be one color plastic throughout and have a solid plastic profile without fillers.

**LENGTH:** Post shall be at specified length plus or minus .250 (6.35mm)

**REFLECTIVE SHEETING:** Shall be of a specified grade and size affixed to the post by the manufacturer.

**FG 95 ANCHOR:** The plastic anchor shall meet the same physical properties as delineator posts, shall be 2.0" (50.8mm) in length, and of sufficient strength so as to resist pull out in multiple high speed impacts. Anchors shall be placed in slots at the bottom tip of posts prior to installation.

**FG 96 STEEL ANCHOR:** The steel anchor unit shall be a hot rolled rail steel or new billet steel meeting the physical requirements of ASTM A499 and the chemical requirements of ASTM A1.

**CONSTRUCTION:** The steel anchor shall be a uniform flanged channel post with nominal weight of 1.12 #/ft. (.418 kg) before holes are punched. Anchors shall be 12" or 18" (457.2mm) in length and have a sufficient number of 3/8" (9.5mm) diameter holes on 1" (25.38mm) centers to facilitate attachment of flexible guide posts. Anchors shall be supplied with attachment hardware as recommended by the manufacturer.

**Posts shall satisfy the following typical properties**

| PHYSICAL PROPERTIES           | RESULTS    | ASTM |
|-------------------------------|------------|------|
| Specific Gravity,             | 1.20 (Typ) | D792 |
| Water Absorbtion, 24 hrs, 73F | .576       | D570 |
| MECHANICAL PROPERTIES         |            |      |
| Tensile Elongation at break   | 30% Min    | D638 |
| Rockwell Hardness R-Scale     | 100 Min    | D785 |
| IZOD IMPACT                   |            |      |
| 1/8" Notched (ft. lbs./in.)   | 12.0 Min   | D256 |
| 1/8" Unotched                 | No Break   | D256 |

**RECYCLABLE / RETURNABLE:**

Flexible posts will be recyclable by the manufacturer. Posts that become damaged under normal use will be returned to the manufacturer, reground the reused to make other delineation products. The manufacturer will offer credit toward the next purchase when products are returned.

**Important Notice To Purchaser**

The following is made in lieu of all warranties, expressed or implied, including the implied warranties of merchantability and fitness for purpose: Seller's and manufacturer's only obligation shall be to replace such quantity of the product proved to be defective. Before using, user shall determine the suitability of the product for its intended use, and user assumes all risk and liability whatsoever in connection therewith. Neither manufacturer nor seller shall be liable either in tort or in contract for any loss or damage, direct, incidental, or consequential, arising out of the use of or the inability to use the product.

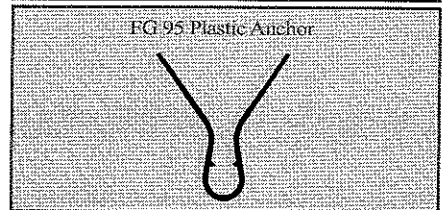
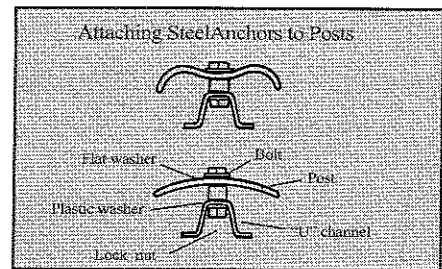

U.S.PAT. 5,028,166



"new name. same great company"

3110 70th Avenue East / Tacoma, WA 98424 / (253) 284 8000 Fax (253) 284 8080  
e-mail: hwysales@bunzltacoma.com / web address: www.bunzltacoma.com

Authorized Dealer



Davidson Traffic Control Products

## Instructions for use of FG™ 102 System

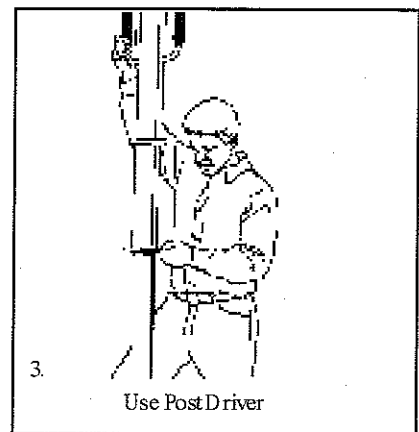
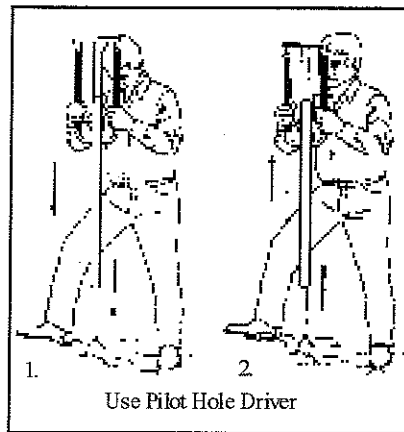
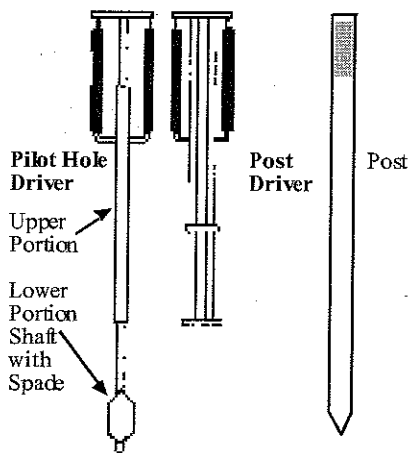

### Using the FG™ 102 Pilot Hole Driver and FG 102 Post Driver

1. Place spade end of FG™ 102 Pilot Hole Driver at desired point of entry. Grasping the handles located at the top of driver with both hands, slide the upper portion of the driver up and then downward with force sufficient to drive the spade end into the soil. Repeat until spade end and shaft is totally submerged in soil, approximately 18 inches.
2. The Pilot Hole Driver can be removed from the soil by again sliding the upper portion of the Driver up and down, this time creating

impact at the top of the Driver. Repeat until entire unit is dislodged from the soil.

3. Place the post (with anchor placed into anchor slot, if anchors are being used) into Post Driver. Picking up the entire unit (Post Driver with post inside), place the tip of the post into the pilot hole. Slide the Post Driver up a few inches and then drive down onto the post. This usually can be accomplished without a great deal of force. (Pressure on the downstroke can also be increased, if desirable, after post is at mid-point into pilot hole.) Repeat until post has been driven to full 18" depth.

**Alternative Installation Methods** for the FG 400 & 500 series delineator posts include various mechanical systems. Auger installations have proven to be effective and efficient methods. A four-inch auger is recommended. The auger shall be positioned at the hole location, auger a hole to the proper installation depth, typically 18 inches. The post face shall be aligned such that it is perpendicular to traffic flow. The post hole area must then be backfilled and tamped as necessary. Power driver tools also may be used in lieu of the pilot hole driver. Using a power tool with a spade can save time and labor when driving pilot





# Instructions for use of FG<sup>TM</sup> 103 Post Driver and FG<sup>TM</sup> 100 Power Tools

## FG<sup>TM</sup> 103 Post Driver

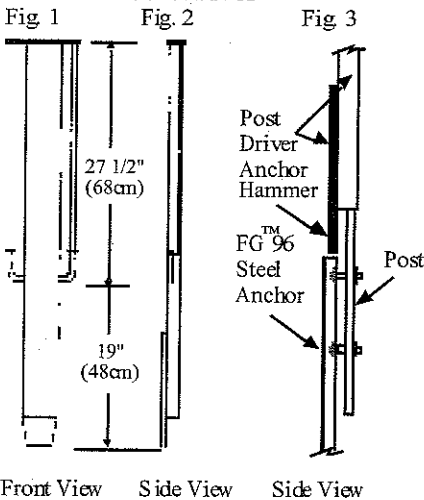

and down, striking the anchor hammer against the top of the steel anchor.

3. Repeat the process until the post is driven to the proper burial depth.

**Flexi-Guide 400 & 500 Series delineator posts with 12" and 18" U-Channel Anchors** can be installed using various power driver tools including gas-powered, pneumatic and electric demolition hammers. By simply attaching the fitted tool to your power driver, you are ready to decrease installation time and increase your crews efficiency.

**The FG 104** is a simple chisel/fork with a 3/4" hex, 5/8" hex spline-shank for use with various driver types.

**The FG 105** is a solid one-piece fitted driver head with a 7/8" hex shank. Custom shanks are available to fit various driver types.

**FG 106** is a two-piece tool; separate fitted driver head and tamper rod with custom shank for use with various driver types.

1. Select the proper driver tool for your equipment. Custom tools are available, contact your local sales representative for more details.

2. At the installation location of the

delineator, loosen and remove the top 2-3" of soil (approx. 5" diam.) with a shovel or power tool. It is important that the top of the U-channel anchor is driven 2-3" below the ground surface

3. Fix the end of the fitted tool on top of the U-channel anchor. Align the face of the post perpendicular to traffic flow. Drive U-channel anchor until it is 2-3" below the ground surface. Ensure post is kept as vertical as possible. Backfill and tamp the area around the post as necessary.

Call your factory representative for technical questions and support.

### Using the FG 103 Post Driver with FG 96 Steel Anchor (SA)

The FG 103 is designed for use with a steel U-channel anchor. It eliminates the need for a pilot hole and allows the post to be driven into compacted or rocky soils.

1. Place delineator post with steel anchor attached into the FG 103 Driver (See Figure 3).

2. Holding the FG 103 with the post inside, position the steel anchor at the desired installation location. Ensure the post is vertical and front face is perpendicular to traffic flow. Grasp the handles and slide the FG 103 up

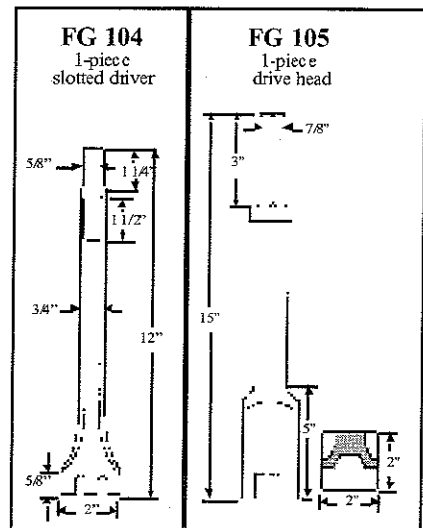

3110 70th Avenue East / Tacoma, WA 98424 / (253) 284 8000 Fax (253) 284 8080  
 e-mail: hwysales@bunzlta.com / web address: www.bunzlta.com

Authorized Dealer

# Installation Instructions for use of the FG 103 Post Driver



**1. Place Delineator Post into Driver**



**2. Position Anchor at Location**



**3. Grasp the Handles and  
Slide Up & Down**

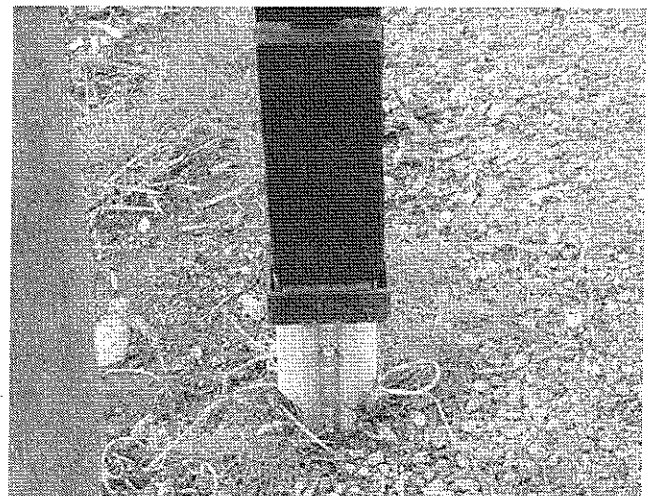

**4. Repeat Process Until Anchor is at  
Least 2" (5cm) below ground.**

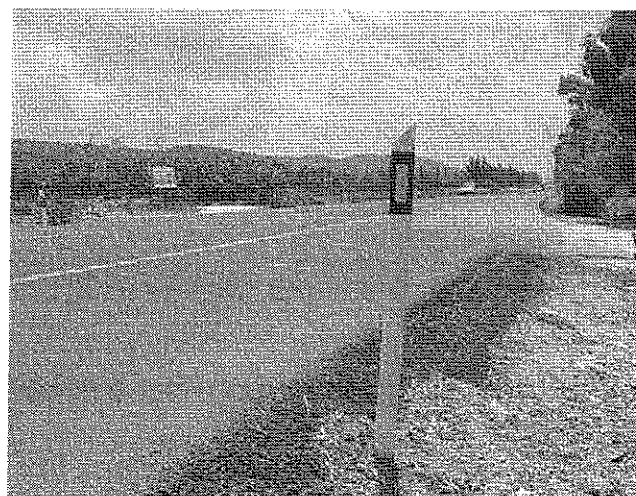

**FG 500 Post Properly Installed**



## Instructions for use of FG 104 & 105 Power Driver Tools

Flexi-Guide 400 & 500 Series Roadside Delineator posts with 12" and 18" steel U-Channel anchors can be installed using various power driver tools including gas-powered, pneumatic and electric demolition hammers. By simply attaching the fitted tool to your power driver, you are ready to decrease installation time and increase your crew's efficiency.

The FG 104 is a simple 'fork' tool - 5/8" x 3" shaft for use with all types of drivers. The FG 105 is a solid one-piece fitted tool - 7/8" hex x 4" shaft for use with all drivers.

1. Select the proper driver tool for your equipment. Custom tools are also available; contact your local sales representative for more details.
2. At the installation location of the delineator, loosen and remove the top 3 to 4 inches of soil (approx. 5" diameter) with a shovel or power tool. It is important the top of the u-channel anchor is driven 3-4" below the ground surface and then backfilled.
3. Fix the end of the fitted tool on the top of the u-channel anchor. Align the face of the post perpendicular to traffic flow. Drive u-channel anchor until it is 3 to 4 inches below the ground surface. Ensure post is kept as vertical as possible. Backfill and tamp the area around the post as necessary.
4. Repeat steps 2 and 3 for additional installations. Call your factory representative for technical questions and support.

5. **Important Notice To Purchaser**

The following is made in lieu of all warranties, expressed or implied, including the implied warranties of merchantability and fitness for purpose: Seller's and manufacturer's only obligation shall be to replace such quantity of the product proved to be defective. Before using, user shall determine the suitability of the product for its intended use, and user assumes all risk and liability whatsoever in connection therewith. Neither manufacturer nor seller shall be liable either in tort or in contract for any loss or damage, direct, incidental, or consequential, arising out of the use of or the inability to use the product.