



State of West Virginia  
 Department of Administration  
 Purchasing Division  
 2019 Washington Street East  
 Post Office Box 50130  
 Charleston, WV 25305-0130

### Request for Quotation

RFQ NUMBER
708EC009

PAGE
1

ADDRESS CORRESPONDENCE TO/ATTENTION OF
MICHAEL AUSTIN 304-558-2402

RFQ COPY

TYPE NAME/ADDRESS HERE

*Henke Manufacturing Corp.*  
*3070 Wilson Ave.*  
*Leavenworth, KS 66048*

VENDOR

SHIP TO

DIVISION OF HIGHWAYS  
 EQUIPMENT DIVISION  
 ROUTE 33  
 BRUSHY FORK ROAD  
 BUCKHANNON, WV  
 26201 304-472-1750

DATE PRINTED	TERMS OF SALE	SHIP VIA	FOB	FREIGHT TERMS
01/16/2008				

BID OPENING DATE: 02/13/2008 BID OPENING TIME 01:30PM

LINE	QUANTITY	UOP	CAT NO	ITEM NUMBER	UNIT PRICE	AMOUNT
0001	1	EA		765-61	\$7,532. <sup>00</sup>	\$7,532. <sup>00</sup>
SNOWPLOW (HYDRAULIC)  TO PROVIDE 10 FOOT OR 11 FOOT POWER REVERSIBLE SNOWPLOW (HYDRAULIC) PER THE ATTACHED SPECIFICATIONS.  THERE WILL BE A MANDATORY PRE-BID CONFERENCE AT THE STATE CAPITOL COMPLEX, BUILDING 15, 2019 WASHINGTON ST. EAST. CHARLESTON, WV 25305 AT 10:00 AM ON 01/31/08. FAILURE TO ATTEND THE PRE-BID WILL RESULT IN BID DISQUALIFICATION.  QUESTIONS: WRITTEN QUESTIONS WILL BE ACCEPTED THROUGH CLOSE OF BUSINESS (5:00 PM EST.) ON MONDAY 01/28/2008. SEND YOUR QUESTIONS TO: PURCHASING DIVISION ATTENTION: MICHAEL AUSTIN 2019 WASHINGTON STREET EAST CHARLESTON, WV 25305  QUESTIONS MAY BE SENT VIA FAX, E-MAIL OR REGULAR MAIL E-MAIL: MICHAEL.D.AUSTIN@WV.GOV FAX: 304-558-4115 IT IS THE VENDORS RESPONSIBILITY TO VERIFY THAT THEIR QUESTIONS HAVE BEEN RECEIVED BY CALLING 304-558-2402.  EXHIBIT 2  LIFE OF CONTRACT: THIS CONTRACT BECOMES EFFECTIVE ON ..... AND EXTENDS FOR A PERIOD OF ONE (1) YEAR OR UNTIL SUCH "REASONABLE TIME" THEREAFTER AS IS NECESSARY TO OBTAIN A NEW CONTRACT OR RENEW THE						

RECEIVED  
 2008 MAR -4 A 10:20  
 PURCHASING DIVISION  
 STATE OF WV

SEE REVERSE SIDE FOR TERMS AND CONDITIONS			
SIGNATURE <i>Michael Morris</i>	TELEPHONE <i>913-682-9000</i>	DATE <i>2/5/08</i>	
FEIN <i>48-1131942</i>	ADDRESS CHANGES TO BE NOTED ABOVE		

WHEN RESPONDING TO RFQ, INSERT NAME AND ADDRESS IN SPACE ABOVE LABELED 'VENDOR'



State of West Virginia  
 Department of Administration  
 Purchasing Division  
 2019 Washington Street East  
 Post Office Box 50130  
 Charleston, WV 25305-0130

# Request for Quotation

RFQ NUMBER:  
**708EC009**

PAGE:  
**2**

ADDRESS CORRESPONDENCE TO ATTENTION OF:  
**MICHAEL AUSTIN  
 304-558-2402**

RFQ COPY  
 TYPE NAME/ADDRESS HERE

**DIVISION OF HIGHWAYS  
 EQUIPMENT DIVISION  
 ROUTE 33  
 BRUSHY FORK ROAD  
 BUCKHANNON, WV  
 26201 304-472-1750**

DATE PRINTED	TERMS OF SALE	SHIP VIA	F.O.B.	FREIGHT TERMS
01/16/2008				

BID OPENING DATE: **02/13/2008** BID OPENING TIME **01:30PM**

LINE	QUANTITY	UOP	CAT NO	ITEM NUMBER	UNIT PRICE	AMOUNT
<p>ORIGINAL CONTRACT. THE "REASONABLE TIME" PERIOD SHALL NOT EXCEED TWELVE (12) MONTHS. DURING THIS "REASONABLE TIME" THE VENDOR MAY TERMINATE THIS CONTRACT FOR ANY REASON UPON GIVING THE DIRECTOR OF PURCHASING THIRTY (30) DAYS WRITTEN NOTICE.</p> <p>UNLESS SPECIFIC PROVISIONS ARE STIPULATED IN THIS CONTRACT DOCUMENT, THE TERMS, CONDITIONS, AND PRICING SET HEREIN ARE FIRM FOR THE LIFE OF THE CONTRACT.</p> <p>RENEWAL: THIS CONTRACT MAY BE RENEWED UPON THE MUTUAL WRITTEN CONSENT OF THE SPENDING UNIT AND VENDOR, SUBMITTED TO THE DIRECTOR OF PURCHASING THIRTY (30) DAYS PRIOR TO THE EXPIRATION DATE. SUCH RENEWAL SHALL BE IN ACCORDANCE WITH THE TERMS AND CONDITIONS OF THE ORIGINAL CONTRACT AND SHALL BE LIMITED TO TWO (2) ONE (1) YEAR PERIODS.</p> <p>CANCELLATION: THE DIRECTOR OF PURCHASING RESERVES THE RIGHT TO CANCEL THIS CONTRACT IMMEDIATELY UPON WRITTEN NOTICE TO THE VENDOR IF THE COMMODITIES AND/OR SERVICES SUPPLIED ARE OF AN INFERIOR QUALITY OR DO NOT CONFORM WITH THE SPECIFICATIONS OF THE BID AND CONTRACT HEREIN.</p> <p>OPEN MARKET CLAUSE: THE DIRECTOR OF PURCHASING MAY AUTHORIZE A SPENDING UNIT TO PURCHASE ON THE OPEN MARKET, WITHOUT THE FILING OF A REQUISITION OR COST ESTIMATE, ITEMS SPECIFIED ON THIS CONTRACT FOR IMMEDIATE DELIVERY IN EMERGENCIES DUE TO UNFORESEEN CAUSES (INCLUDING BUT NOT LIMITED TO DELAYS IN TRANSPORTATION OR AN UNANTICIPATED INCREASE IN THE VOLUME OF WORK).</p> <p>QUANTITIES: QUANTITIES LISTED IN THE REQUISITION ARE APPROXIMATIONS ONLY, BASED ON ESTIMATES SUPPLIES BY THE STATE SPENDING UNIT. IT IS UNDERSTOOD AND AGREED THAT THE CONTRACT SHALL COVER THE QUANTITIES ACTUALLY</p>						

SEE REVERSE SIDE FOR TERMS AND CONDITIONS

SIGNATURE <b>Michael Morris</b>	TELEPHONE <b>913-662-6000</b>	DATE <b>2/12/08</b>
TITLE <b>Inside Sales Mgr</b>	FEIN <b>48-1131942</b>	ADDRESS CHANGES TO BE NOTED ABOVE

WHEN RESPONDING TO RFQ, INSERT NAME AND ADDRESS IN SPACE ABOVE LABELED 'VENDOR'



State of West Virginia  
 Department of Administration  
 Purchasing Division  
 2019 Washington Street East  
 Post Office Box 50130  
 Charleston, WV 25305-0130

# Request for Quotation

RFQ NUMBER:  
**708EC009**

PAGE:  
**3**

ADDRESS CORRESPONDENCE TO ATTENTION OF:  
**MICHAEL AUSTIN  
 304-558-2402**

RFQ COPY  
 TYPE NAME/ADDRESS HERE

VENDOR

SHIP TO

**DIVISION OF HIGHWAYS  
 EQUIPMENT DIVISION  
 ROUTE 33  
 BRUSHY FORK ROAD  
 BUCKHANNON, WV  
 26201 304-472-1750**

DATE PRINTED <b>01/16/2008</b>	TERMS OF SALE	SHIP VIA	F.O.B.	FREIGHT TERMS
-----------------------------------	---------------	----------	--------	---------------

BID OPENING DATE: **02/13/2008** BID OPENING TIME **01:30PM**

LINE	QUANTITY	UOP	CAT NO	ITEM NUMBER	UNIT PRICE	AMOUNT
<p>ORDERED FOR DELIVERY DURING THE TERM OF CONTRACT, WHETHER MORE OR LESS THAN THE QUANTITIES SHOWN.</p> <p>ORDERING PROCEDURE: SPENDING UNIT(S) SHALL ISSUE A WRITTEN EQUIPMENT CONTRACT ORDER (FORM NUMBER WV-35) FOR COMMODITIES COVERED BY THIS CONTRACT. THE ORIGINAL WV-35 MUST BE SENT TO THE PURCHASING DIVISION OF THE DEPARTMENT OF ADMINISTRATION. AFTER APPROVAL AND ENCUMBRANCE, ONE COPY OF THE PURCHASE ORDER WILL BE RETURNED TO THE SPENDING UNIT AND ONE COPY FORWARDED TO THE VENDOR AS AUTHORIZATION FOR SHIPMENT. NO ORDER IS VALID UNLESS APPROVED AND ENCUMBERED BY THE PURCHASING DIVISION.</p> <p>BANKRUPTCY: IN THE EVENT THE VENDOR/CONTRACTOR FILES FOR BANKRUPTCY PROTECTION, THIS CONTRACT IS AUTOMATICALLY NULL AND VOID, AND IS TERMINATED WITHOUT FURTHER ORDER.</p> <p>REV. 9/98</p> <p>EXHIBIT 6</p> <p>PRICE ADJUSTMENT PROVISION:          THE STATE OF WEST VIRGINIA WILL CONSIDER BIDS THAT CONTAIN PROVISIONS FOR PRICE ADJUSTMENTS PRIOR TO THE ORIGINAL EXPIRATION OF THE CONTRACT, PROVIDED THAT SUCH PRICE ADJUSTMENT COVERS BOTH UPWARD AND DOWNWARD MOVEMENT OF THE COMMODITY PRICE, AND THAT ADJUSTMENT IS BASED ON THE "PASS THROUGH" INCREASE OR DECREASE OF RAW MATERIALS AND/OR LABOR, WHICH MAKE UP ALL OR A SUBSTANTIAL PART OF A PRODUCT. ADJUSTMENTS ARE TO BE BASED UPON AN ACTUAL DOLLAR FIGURE, NOT A PERCENTAGE. ALL PRICE ADJUSTMENT REQUESTS MUST BE SUBSTANTIATED IN A MANNER ACCEPTABLE TO THE DIRECTOR PURCHASING, E.G.</p>						

SEE REVERSE SIDE FOR TERMS AND CONDITIONS

SIGNATURE **Michael Mowis** TELEPHONE **913 6824000** DATE **2/12/08**  
 TITLE **Inside Sales Mgr** FEIN **48-1131942** ADDRESS CHANGES TO BE NOTED ABOVE

WHEN RESPONDING TO RFQ, INSERT NAME AND ADDRESS IN SPACE ABOVE LABELED 'VENDOR'



State of West Virginia  
 Department of Administration  
 Purchasing Division  
 2019 Washington Street East  
 Post Office Box 50130  
 Charleston, WV 25305-0130

# Request for Quotation

RFP NUMBER  
**708EC009**

PAGE  
**4**

ADDRESS CORRESPONDENCE TO ATTENTION OF  
**MICHAEL AUSTIN  
 304-558-2402**

VENDOR

RFQ COPY  
 TYPE NAME/ADDRESS HERE

SHIP TO

DIVISION OF HIGHWAYS  
 EQUIPMENT DIVISION  
 ROUTE 33  
 BRUSHY FORK ROAD  
 BUCKHANNON, WV  
 26201 304-472-1750

DATE PRINTED	TERMS OF SALE	SHIP VIA	F.O.B.	FREIGHT TERMS
01/16/2008				

BID OPENING DATE: **02/13/2008** BID OPENING TIME **01:30PM**

LINE	QUANTITY	UOP	CAT. NO.	ITEM NUMBER	UNIT PRICE	AMOUNT
<p>GOVERNMENTAL BENCH MARKS, GENERAL MARKET INCREASE, PUBLISHED PRICE LISTS. SUCH REQUESTS FOR AND INCREASE SHOULD BE RECEIVED IN WRITING BY THE DIRECTOR OF PURCHASING AT LEAST 30 DAYS IN ADVANCE OF THE EFFECTIVE DATE OF THE INCREASE. ANY TIME THE VENDOR REQUESTS A PRICE ADJUSTMENT, THE PURCHASING DIVISION MAY EITHER ACCEPT THE PRICE ADJUSTMENT AND AMEND THE CONTRACT ACCORDINGLY OR REJECT THE ADJUSTMENT IN ITS ENTIRETY AND CANCEL THE CONTRACT.</p> <p>EXHIBIT 10</p> <p style="text-align: right;">REQUISITION NO.: <b>708EC009</b></p> <p>ADDENDUM ACKNOWLEDGEMENT</p> <p>I HEREBY ACKNOWLEDGE RECEIPT OF THE FOLLOWING CHECKED ADDENDUM(S) AND HAVE MADE THE NECESSARY REVISIONS TO MY PROPOSAL, PLANS AND/OR SPECIFICATION, ETC.</p> <p>ADDENDUM NO.'S:</p> <p>NO. 1 ... <b>YES</b> ...</p> <p>NO. 2 ... <b>YES</b> ...</p> <p>NO. 3 .....</p> <p>NO. 4 .....</p> <p>NO. 5 .....</p> <p>I UNDERSTAND THAT FAILURE TO CONFIRM THE RECEIPT OF THE ADDENDUM(S) MAY BE CAUSE FOR REJECTION OF BIDS.</p>						

SEE REVERSE SIDE FOR TERMS AND CONDITIONS

SIGNATURE **Michael Maus** TELEPHONE **913 682 9000** DATE **2/2/08**  
 TITLE **Inside Sales Mgr** FEIN **48-1131942** ADDRESS CHANGES TO BE NOTED ABOVE

WHEN RESPONDING TO RFQ, INSERT NAME AND ADDRESS IN SPACE ABOVE LABELED 'VENDOR'



State of West Virginia  
 Department of Administration  
 Purchasing Division  
 2019 Washington Street East  
 Post Office Box 50130  
 Charleston, WV 25305-0130

# Request for Quotation

RFQ NUMBER:  
**708EC009**

PAGE:  
**5**

ADDRESS CORRESPONDENCE TO ATTENTION OF:  
**MICHAEL AUSTIN  
 304-558-2402**

RFQ COPY  
 TYPE NAME/ADDRESS HERE

MURKIN

SHIP TO

DIVISION OF HIGHWAYS  
 EQUIPMENT DIVISION  
 ROUTE 33  
 BRUSHY FORK ROAD  
 BUCKHANNON, WV  
 26201 304-472-1750

DATE PRINTED	TERMS OF SALE	SHIP VIA	F.O.B.	FREIGHT TERMS
01/16/2008				

BID OPENING DATE: **02/13/2008** BID OPENING TIME **01:30PM**

LINE	QUANTITY	UOP	CAT. NO.	ITEM NUMBER	UNIT PRICE	AMOUNT
<p>VENDOR MUST CLEARLY UNDERSTAND THAT ANY VERBAL REPRESENTATION MADE OR ASSUMED TO BE MADE DURING ANY ORAL DISCUSSION HELD BETWEEN VENDOR'S REPRESENTATIVES AND ANY STATE PERSONNEL IS NOT BINDING. ONLY THE INFORMATION ISSUED IN WRITING AND ADDED TO THE SPECIFICATIONS BY AN OFFICIAL ADDENDUM IS BINDING.</p> <p style="text-align: center;"> <i>Michael Monts</i>            .....            SIGNATURE  <i>Henke Mfg. Corp</i>            .....            COMPANY  <i>2/1/08</i>            .....            DATE         </p> <p>REV. 11/96</p> <p style="text-align: center;">VENDOR PREFERENCE CERTIFICATE</p> <p>CERTIFICATION AND APPLICATION* IS HEREBY MADE FOR PREFERENCE IN ACCORDANCE WITH WEST VIRGINIA CODE, 5A-3-37 (DOES NOT APPLY TO CONSTRUCTION CONTRACTS).</p> <p>A. APPLICATION IS MADE FOR 2.5% PREFERENCE FOR THE REASON CHECKED:</p> <p>( ) BIDDER IS AN INDIVIDUAL RESIDENT VENDOR AND HAS RESIDED CONTINUOUSLY IN WEST VIRGINIA FOR FOUR (4) YEARS IMMEDIATELY PRECEDING THE DATE OF THIS CERTIFICATION; OR</p> <p>( ) BIDDER IS A PARTNERSHIP, ASSOCIATION OR CORPORATION RESIDENT VENDOR AND HAS MAINTAINED ITS HEAD-</p>						

SEE REVERSE SIDE FOR TERMS AND CONDITIONS

SIGNATURE <i>Michael Monts</i>	TELEPHONE <i>913-682-9000</i>	DATE <i>2/1/08</i>
<i>Inside Sales Mgr</i>	FEIN <i>48-1171942</i>	ADDRESS CHANGES TO BE NOTED ABOVE

WHEN RESPONDING TO RFQ, INSERT NAME AND ADDRESS IN SPACE ABOVE LABELED 'VENDOR'



State of West Virginia  
 Department of Administration  
 Purchasing Division  
 2019 Washington Street East  
 Post Office Box 50130  
 Charleston, WV 25305-0130

# Request for Quotation

RFQ NUMBER:  
**708EC009**

PAGE:  
**6**

ADDRESS CORRESPONDENCE TO ATTENTION OF:  
**MICHAEL AUSTIN  
 304-558-2402**

RFQ COPY  
 TYPE NAME/ADDRESS HERE

VENDOR

SHIP TO

DIVISION OF HIGHWAYS  
 EQUIPMENT DIVISION  
 ROUTE 33  
 BRUSHY FORK ROAD  
 BUCKHANNON, WV  
 26201 304-472-1750

DATE PRINTED	TERMS OF SALE	SHIP VIA	FOB	FREIGHT TERMS
01/16/2008				

BID OPENING DATE: **02/13/2008** BID OPENING TIME **01:30PM**

LINE	QUANTITY	UOP	CAT NO.	ITEM NUMBER	UNIT PRICE	AMOUNT
<p>QUARTERS OR PRINCIPAL PLACE OF BUSINESS CONTINUOUSLY IN WEST VIRGINIA FOR FOUR (4) YEARS IMMEDIATELY PRECEDING THE DATE OF THIS CERTIFICATION; OR 80% OF THE OWNERSHIP INTEREST OF BIDDER IS HELD BY ANOTHER INDIVIDUAL, PARTNERSHIP, ASSOCIATION OR CORPORATION RESIDENT VENDOR WHO HAS MAINTAINED ITS HEADQUARTERS OR PRINCIPAL PLACE OF BUSINESS CONTINUOUSLY IN WEST VIRGINIA FOR FOUR (4) YEARS IMMEDIATELY PRECEDING THE DATE OF THIS CERTIFICATION; OR</p> <p>( ) BIDDER IS A CORPORATION NONRESIDENT VENDOR WHICH HAS AN AFFILIATE OR SUBSIDIARY WHICH EMPLOYS A MINIMUM OF ONE HUNDRED STATE RESIDENTS AND WHICH HAS MAINTAINED ITS HEADQUARTERS OR PRINCIPAL PLACE OF BUSINESS WITHIN WEST VIRGINIA CONTINUOUSLY FOR THE FOUR (4) YEARS IMMEDIATELY PRECEDING THE DATE OF THIS CERTIFICATION.</p> <p>B. APPLICATION IS MADE FOR 2.5% PREFERENCE FOR THE REASON CHECKED:</p> <p>( ) BIDDER IS A RESIDENT VENDOR WHO CERTIFIES THAT, DURING THE LIFE OF THE CONTRACT, ON AVERAGE AT LEAST 75% OF THE EMPLOYEES WORKING ON THE PROJECT BEING BID ARE RESIDENTS OF WEST VIRGINIA WHO HAVE RESIDED IN THE STATE CONTINUOUSLY FOR THE TWO YEARS IMMEDIATELY PRECEDING SUBMISSION OF THIS BID;</p> <p>OR</p> <p>( ) BIDDER IS A NONRESIDENT VENDOR EMPLOYING A MINIMUM OF ONE HUNDRED STATE RESIDENTS OR IS A NONRESIDENT VENDOR WITH AN AFFILIATE OR SUBSIDIARY WHICH MAINTAINS ITS HEADQUARTERS OR PRINCIPAL PLACE OF BUSINESS WITHIN WEST VIRGINIA EMPLOYING A MINIMUM OF ONE HUNDRED STATE RESIDENTS WHO CERTIFIES THAT, DURING THE LIFE OF THE CONTRACT, ON AVERAGE AT LEAST 75% OF THE EMPLOYEES OR BIDDERS' AFFILIATE'S OR</p>						

SEE REVERSE SIDE FOR TERMS AND CONDITIONS

SIGNATURE *Michael Monis* TELEPHONE *913 682 9000* DATE *2/12/08*  
 Inside Sales Manager FEIN *48-1131942* ADDRESS CHANGES TO BE NOTED ABOVE

WHEN RESPONDING TO RFQ, INSERT NAME AND ADDRESS IN SPACE ABOVE LABELED 'VENDOR'



State of West Virginia  
 Department of Administration  
 Purchasing Division  
 2019 Washington Street East  
 Post Office Box 50130  
 Charleston, WV 25305-0130

# Request for Quotation

RFO NUMBER  
**708EC009**

PAGE  
**7**

ADDRESS CORRESPONDENCE TO ATTENTION OF:  
**MICHAEL AUSTIN  
 304-558-2402**

RFQ COPY  
 TYPE NAME/ADDRESS HERE

DIVISION OF HIGHWAYS  
 EQUIPMENT DIVISION  
 ROUTE 33  
 BRUSHY FORK ROAD  
 BUCKHANNON, WV  
 26201 304-472-1750

DATE PRINTED <b>01/16/2008</b>	TERMS OF SALE	SHIP VIA	F.O.B.	FREIGHT TERMS
BID OPENING DATE: <b>02/13/2008</b>		BID OPENING TIME <b>01:30PM</b>		

LINE	QUANTITY	UOP	CAT NO	ITEM NUMBER	UNIT PRICE	AMOUNT
<p>SUBSIDIARY'S EMPLOYEES ARE RESIDENTS OF WEST VIRGINIA WHO HAVE RESIDED IN THE STATE CONTINUOUSLY FOR THE TWO YEARS IMMEDIATELY PRECEDING SUBMISSION OF THIS BID.</p> <p>BIDDER UNDERSTANDS IF THE SECRETARY OF TAX &amp; REVENUE DETERMINES THAT A BIDDER RECEIVING PREFERENCE HAS FAILED TO CONTINUE TO MEET THE REQUIREMENTS FOR SUCH PREFERENCE, THE SECRETARY MAY ORDER THE DIRECTOR OF PURCHASING TO: (A) RESCIND THE CONTRACT OR PURCHASE ORDER ISSUED; OR (B) ASSESS A PENALTY AGAINST SUCH BIDDER IN AN AMOUNT NOT TO EXCEED 5% OF THE BID AMOUNT AND THAT SUCH PENALTY WILL BE PAID TO THE CONTRACTING AGENCY OR DEDUCTED FROM ANY UNPAID BALANCE ON THE CONTRACT OR PURCHASE ORDER.</p> <p>BY SUBMISSION OF THIS CERTIFICATE, BIDDER AGREES TO DISCLOSE ANY REASONABLY REQUESTED INFORMATION TO THE PURCHASING DIVISION AND AUTHORIZES THE DEPARTMENT OF TAX AND REVENUE TO DISCLOSE TO THE DIRECTOR OF PURCHASING APPROPRIATE INFORMATION VERIFYING THAT BIDDER HAS PAID THE REQUIRED BUSINESS TAXES, PROVIDED THAT SUCH INFORMATION DOES NOT CONTAIN THE AMOUNTS OF TAXES PAID NOR ANY OTHER INFORMATION DEEMED BY THE TAX COMMISSIONER TO BE CONFIDENTIAL.</p> <p>UNDER PENALTY OF LAW FOR FALSE SWEARING (WEST VIRGINIA CODE 61-5-3), BIDDER HEREBY CERTIFIES THAT THIS CERTIFICATE IS TRUE AND ACCURATE IN ALL RESPECTS; AND THAT IF A CONTRACT IS ISSUED TO BIDDER AND IF ANYTHING CONTAINED WITHIN THIS CERTIFICATE CHANGES DURING THE TERM OF THE CONTRACT, BIDDER WILL NOTIFY THE PURCHASING DIVISION IN WRITING IMMEDIATELY.</p> <p>BIDDER: <i>Michael Morris for Henke Manufacturing Corp</i></p>						

SEE REVERSE SIDE FOR TERMS AND CONDITIONS

SIGNATURE *Michael Morris* TELEPHONE *978 682 9000* DATE *2/12/08*

*Inside Sales Mgr* FEIN *48-1131942* ADDRESS CHANGES TO BE NOTED ABOVE

WHEN RESPONDING TO RFQ, INSERT NAME AND ADDRESS IN SPACE ABOVE LABELED 'VENDOR'



State of West Virginia  
 Department of Administration  
 Purchasing Division  
 2019 Washington Street East  
 Post Office Box 50130  
 Charleston, WV 25305-0130

# Request for Quotation

RFQ NUMBER  
**708EC009**

PAGE  
**8**

ADDRESS CORRESPONDENCE TO ATTENTION OF:  
**MICHAEL AUSTIN  
 304-558-2402**

RFQ COPY  
 TYPE NAME/ADDRESS HERE

**DIVISION OF HIGHWAYS  
 EQUIPMENT DIVISION  
 ROUTE 33  
 BRUSHY FORK ROAD  
 BUCKHANNON, WV  
 26201 304-472-1750**

DATE PRINTED	TERMS OF SALE	SHIP VIA	F.O.B.	FREIGHT TERMS
01/16/2008				

BID OPENING DATE: **02/13/2008** BID OPENING TIME **01:30PM**

LINE	QUANTITY	UOP	CAT. NO.	ITEM NUMBER	UNIT PRICE	AMOUNT
<p>DATE: <b>2/7/08</b></p> <p>SIGNED: <b>Michael Monis</b></p> <p>TITLE: <b>Inside Sales Mgr.</b></p> <p>* CHECK ANY COMBINATION OF PREFERENCE CONSIDERATION(S) IN EITHER "A" OR "B", OR BOTH "A" AND "B" WHICH YOU ARE ENTITLED TO RECEIVE. YOU MAY REQUEST UP TO THE MAXIMUM 5% PREFERENCE FOR BOTH "A" AND "B". (REV. 12/00)</p> <p>NOTICE</p> <p>A SIGNED BID MUST BE SUBMITTED TO:</p> <p>DEPARTMENT OF ADMINISTRATION          PURCHASING DIVISION          BUILDING 15          2019 WASHINGTON STREET, EAST          CHARLESTON, WV 25305-0130</p> <p>THE BID SHOULD CONTAIN THIS INFORMATION ON THE FACE OF THE ENVELOPE OR THE BID MAY NOT BE CONSIDERED:</p> <p>SEALED BID</p> <p>BUYER: <b>33</b></p> <p>RFQ. NO.: <b>708EC009</b></p> <p>BID OPENING DATE: <b>02/13/2008</b></p>						

SEE REVERSE SIDE FOR TERMS AND CONDITIONS

SIGNATURE **Michael Monis** TELEPHONE **304-558-2402** DATE **2/7/08**  
 TITLE **Inside Sales Mgr.** FEIN **48-1131942** ADDRESS CHANGES TO BE NOTED ABOVE

WHEN RESPONDING TO RFQ, INSERT NAME AND ADDRESS IN SPACE ABOVE LABELED 'VENDOR'





State of West Virginia  
 Department of Administration  
 Purchasing Division  
 2019 Washington Street East  
 Post Office Box 50130  
 Charleston, WV 25305-0130

# Request for Quotation

RFQ NUMBER:  
**708EC009**

PAGE:  
**9**

ADDRESS CORRESPONDENCE TO ATTENTION OF:  
**MICHAEL AUSTIN  
 304-558-2402**

RFQ COPY  
 TYPE NAME/ADDRESS HERE

VENDOR

SHIP TO

**DIVISION OF HIGHWAYS  
 EQUIPMENT DIVISION  
 ROUTE 33  
 BRUSHY FORK ROAD  
 BUCKHANNON, WV  
 26201 304-472-1750**

DATE PRINTED	TERMS OF SALE	SHIP VIA	FOB	FREIGHT TERMS
01/16/2008				

BID OPENING DATE: **02/13/2008** BID OPENING TIME **01:30PM**

LINE	QUANTITY	UOP	CAT NO	ITEM NUMBER	UNIT PRICE	AMOUNT
BID OPENING TIME:				1:30 PM		
PLEASE PROVIDE A FAX NUMBER IN CASE IT IS NECESSARY TO CONTACT YOU REGARDING YOUR BID:						
				913-682-0300		
CONTACT PERSON (PLEASE PRINT CLEARLY):						
				Michael Morris		
***** THIS IS THE END OF RFQ 708EC009 ***** TOTAL:						\$7,532.00

SEE REVERSE SIDE FOR TERMS AND CONDITIONS

SIGNATURE <i>Michael Morris</i>	TELEPHONE 913 682 9000	DATE 2/12/08
THE INSIDE SALES MAN FEIN 48-1131942	ADDRESS CHANGES TO BE NOTED ABOVE	

WHEN RESPONDING TO RFQ, INSERT NAME AND ADDRESS IN SPACE ABOVE LABELED 'VENDOR'



State of West Virginia  
 Department of Administration  
 Purchasing Division  
 2019 Washington Street East  
 Post Office Box 50130  
 Charleston, WV 25305-0130

**Request for  
 Quotation**

RFQ NUMBER  
**708EC009**

PAGE  
**1**

ADDRESS CORRESPONDENCE TO ATTENTION OF:  
**MICHAEL AUSTIN  
 304-558-2402**

**\*623134258 913-682-9000  
 HENKE MANUFACTURING CORPORATIO  
 3070 WILSON AVE  
 LEAVENWORTH KS 66048**

**DIVISION OF HIGHWAYS  
 EQUIPMENT DIVISION  
 ROUTE 33  
 BRUSHY FORK ROAD  
 BUCKHANNON, WV  
 26201 304-472-1750**

DATE PRINTED <b>02/11/2008</b>	TERMS OF SALE	SHIP VIA	F.O.B.	FREIGHT TERMS
BID OPENING DATE: <b>02/13/2008</b>		BID OPENING TIME <b>01:30PM</b>		

LINE	QUANTITY	UOP	CAT. NO.	ITEM NUMBER	UNIT PRICE	AMOUNT
<b>ADDENDUM NO. 1</b>						
BID OPENING DATE AND TIME CHANGED						
FROM: 02/13/08 AT 1:30 P.M.						
TO: POSTPONE UNTIL FURTHER NOTICE						
NO OTHER CHANGES						
0001	1	EA		765-61		
SNOWPLOW(HYDRAULIC)						
***** THIS IS THE END OF RFQ 708EC009 ***** TOTAL:						

SEE REVERSE SIDE FOR TERMS AND CONDITIONS

SIGNATURE *Michael Monis* TELEPHONE *913-682-9000* DATE *2/12/08*  
 TITLE *Inside Sales Mgr* FEIN *48-1131942*  
 ADDRESS CHANGES TO BE NOTED ABOVE

WHEN RESPONDING TO RFQ, INSERT NAME AND ADDRESS IN SPACE ABOVE LABELED 'VENDOR'



State of West Virginia  
 Department of Administration  
 Purchasing Division  
 2019 Washington Street East  
 Post Office Box 50130  
 Charleston, WV 25305-0130

**Request for  
 Quotation**

RFQ NUMBER  
**708EC009**

PAGE  
**1**

ADDRESS CORRESPONDENCE TO ATTENTION OF  
**MICHAEL AUSTIN  
 304-558-2402**

PROPERTY

\*623134258 913-682-9000  
**HENKE MANUFACTURING CORPORATIO  
 3070 WILSON AVE  
 LEAVENWORTH KS 66048**

SHIP TO

**DIVISION OF HIGHWAYS  
 EQUIPMENT DIVISION  
 ROUTE 33  
 BRUSHY FORK ROAD  
 BUCKHANNON, WV  
 26201 304-472-1750**

DATE PRINTED <b>02/25/2008</b>	TERMS OF SALE	SHIP VIA	FOB	FREIGHT TERMS
BID OPENING DATE: <b>03/05/2008</b>		BID OPENING TIME <b>01:30PM</b>		

LINE	QUANTITY	LOP	CAT. NO.	ITEM NUMBER	UNIT PRICE	AMOUNT
ADDENDUM NO. 2						
CHANGES TO THE SPECIFICATIONS PER THE ATTACHED.						
BID OPENING DATE AND TIME CHANGED						
FROM: POSTPONE UNTIL FURTHER NOTICE						
TO: 03/05/08 AT 1:30 P.M.						
NO OTHER CHANGES.						
0001	1	EA		765-61		
SNOWPLOW (HYDRAULIC)						
***** THIS IS THE END OF RFQ 708EC009 ***** TOTAL:						

SEE REVERSE SIDE FOR TERMS AND CONDITIONS

SIGNATURE <b>Michael Mous</b>	TELEPHONE <b>913-682-9000</b>	DATE <b>2/26/08</b>
TITLE <b>Inside Sales Manager</b>	FEIN <b>48-1131942</b>	ADDRESS CHANGES TO BE NOTED ABOVE

WHEN RESPONDING TO RFQ, INSERT NAME AND ADDRESS IN SPACE ABOVE LABELED 'VENDOR'

## ADDENDUM #2

708EC009

## OPEN END CONTRACT

## 10 FOOT OR 11 FOOT POWER REVERSIBLE SNOWPLOW (HYDRAULIC)

## CHANGES TO SPECIFICATIONS:

## FROM:

3.2 MANDATORY SPECIFICATIONS (1<sup>st</sup> Paragraph 1<sup>st</sup> Sentence Only-Rest Remains The Same)

**All specifications preceded by "shall and/or must" or are stated as a "minimum and/or maximum" are mandatory.**

## TO:

3.2 MANDATORY SPECIFICATIONS (1<sup>st</sup> Paragraph 1<sup>st</sup> Sentence Only-Rest Remains The Same)

**All specifications preceded by "shall, will, and/or must" or are stated as a "minimum and/or maximum" are mandatory.**

## FROM:

4.2 DELIVERY: (2<sup>nd</sup> Paragraph 2<sup>nd</sup> Sentence Only – Rest Remains The Same)  
Delivery is preferred within 135 days after receipt of purchase agreement.

## TO:

4.2 DELIVERY: (2<sup>nd</sup> Paragraph 2<sup>nd</sup> Sentence Only – Rest Remains The Same)  
Delivery is preferred within 135 days to 150 maximum days after receipt of purchase agreement.

## ADD:

6.3 TRAINING (Add to End of 1<sup>st</sup> Paragraph)  
NOTE: Training does not apply to these snowplows

FROM:

7.0 SPECIFICATIONS OF THE QUOTED UNIT AS FOLLOWS: (4<sup>th</sup> Paragraph Only –  
Rest Remains the Same)  
The snowplow to be a Valk RV1142 Reversible Snowplow or equal

TO:

7.0 SPECIFICATIONS OF THE QUOTED UNIT AS FOLLOWS: (4<sup>th</sup> Paragraph Only –  
Rest Remains the Same)  
The snowplow to be a Valk RV1142 11 Foot or RV1042 10 Foot Reversible Snowplow  
or equal

FROM:

7.1.7 Vertical Ribs: Minimum of six (6) vertical ribs, 1/2" by 3" formed steel with two (2)  
ribs at each hinge point.

TO:

7.1.7 Vertical Ribs: Minimum of six (6) vertical ribs, 1/2" by 3" formed steel with two (2)  
ribs at each hinge point OR will accept one (1) full height rib and one (1) short rib  
that doubles the thickness at the hinge point as long as we have six (6) full height  
vertical ribs

FROM:

7.3.3 Tripping mechanism shall be equipped with external cushion spring for absorbing  
shock when moldboard returns to normal plowing position.

TO:

7.3.3 Tripping mechanism shall be equipped with external cushion spring for absorbing  
shock when moldboard returns to normal plowing position OR will accept dual  
compression trip design spring assemblies

FROM:

7.4.4.3 Hydraulic power reverse mechanism shall include a dual cross-over relief  
cushion valve rated at a minimum of 40 G.P.M.

TO:

7.4.4.3 Hydraulic power reverse mechanism shall include a dual cross-over relief  
cushion valve rated at a minimum of 30 G.P.M. to be mounted on the push  
frame assembly and not on the hitch.

## FROM:

7.10 Paint: The entire unit to be painted in accordance with West Virginia Division of Highways requirements as follows:

## TO:

7.10 Paint: The entire unit to be painted or powder coated in accordance with West Virginia of Highways requirements as follows:

## FROM:

7.12 All loose hardware to be in a separate container for each plow and shipped with each plow.

## TO:

7.12 All loose hardware to be in separate water tight containers, attached to and shipped with each plow.

ADDENDUM #2

708EC009

OPEN END CONTRACT

10 FOOT OR 11 FOOT POWER REVERSIBLE SNOWPLOW (HYDRAULIC)

CHANGES TO BIDDER'S EVALUATION REPORT:

X3.2 NO CHANGE REQUIRED

DELIVERY:

X4.2.2 NO CHANGE REQUIRED

DELETE:

X6.3 TRAINING (1<sup>st</sup>, 2<sup>nd</sup>, 3<sup>rd</sup>, 4<sup>th</sup> Paragraphs -- Paragraph 5 Remains)

NOTE: Training does not apply to snowplows

FROM:

X7.0 SPECIFICATIONS OF THE QUOTED UNIT: (Change to Paragraph 8 Only -- Rest Remains the Same)

Manufacturer: \_\_\_\_\_ Model: \_\_\_\_\_

TO:

X7.0 SPECIFICATIONS OF THE QUOTED UNIT: (Change to Paragraph 8 Only -- Rest Remains the Same)

10 Foot Manufacturer: Henke Model: 41R10IS WVO8

11 Foot Manufacturer: Henke Model: 41R11IS WVO8

FROM:

X7.1.7 Number of vertical ribs \_\_\_\_\_ Formed steel \_\_\_\_\_  
How many ribs at each hinge point? \_\_\_\_\_

TO:  
X7.1.7

Number of vertical ribs 6 Formed steel 1/2" x 4" tapered

How many ribs at each hinge point? 1  
OR

1 full height rib and 1 short rib that doubles the thickness at the hinge point as long as we have six (6) full height vertical ribs

FROM:  
X7.3.3

Is tripping mechanism equipped with external cushion spring for absorbing shock? YES NO

TO:  
X7.3.3

Is tripping mechanism equipped with external cushion spring for absorbing shock? ✓ YES NO

OR  
Is it dual compression trip design spring assembly ✓ YES NO

FROM:  
X7.4.4.3

Does hydraulic power reverse mechanism include a dual cross-over relief cushion valve? YES NO Rated at      GPM

TO:  
X7.4.4.3

Does hydraulic power reverse mechanism include a dual cross-over relief cushion valve? ✓ YES NO

Rated at 30 GPM Mounted on the push frame assembly and not on hitch ✓ YES NO

X7.10 Paint: NO CHANGE REQUIRED

FROM:

X7.12 Will all loose hardware be in separate containers for each plow and be shipped with each plow? YES NO

TO:

X7.12 Will all loose hardware be in separate water tight containers attached to and shipped with each plow? ✓ YES NO



WEST VIRGINIA DEPARTMENT OF TRANSPORTATION  
DIVISION OF HIGHWAYS  
EQUIPMENT DIVISION

BIDDER'S EVALUATION REPORT

PROCUREMENT SPECIFICATIONS  
NO. 021-2-C

OPEN END CONTRACT  
10 FOOT OR 11 FOOT POWER REVERSIBLE SNOWPLOW (HYDRAULIC)

NOTE TO BIDDER: Procurement Specification No. 021-2-C, Paragraph 2.0 recommends the completion and submittal of this Report with your bid. Purpose of this Report is to enable the West Virginia Division of Highways Evaluation Committee to make full and fair evaluation of the bid. Addendums in order, along with a summary of exception as a separate attachment, should be with Bidder's Evaluation Report. FAILURE TO SUBMIT THIS REPORT, COMPLETE IN ITS ENTIRETY, MAY SUBJECT THE BIDDER TO DISQUALIFICATION.

Reference Requisition No.: 708EC009

Bidder's Name: Henke Manufacturing Corp.

Address: 3070 Wilson Ave. Leavenworth, KS 66048

Telephone Number: 888-682-9010 x202

Years Bidder has been registered to do business with the State of West Virginia: 11+ YRS.

Years Company has been an authorized dealer for proposed unit: W/A factory direct YRS.

X3.2 Have you complied with all mandatory specifications?  YES  NO

X4.2 DELIVERY:

X4.2.1 Delivery date of completed representative unit: 150-180 Calendar Days After Receipt of Purchase Agreement

X4.2.2 Delivery date of balance of completed units: 150-180 Calendar Days After Receipt of Purchase Agreement

X5.0 AWARD CRITERIA;

OPTION #1 - 10 FOOT

X5.1 Prices for plows in quantities of

1-10	<u>7,532.<sup>00</sup></u>	per unit
11-20	<u>7,381.<sup>00</sup></u>	per unit
21-30	<u>7,233.<sup>12</sup></u>	per unit
31-40	<u>7,089.<sup>00</sup></u>	per unit
41-50	<u>6,947.<sup>00</sup></u>	per unit
51 and over	<u>6,808.<sup>00</sup></u>	per unit

OPTION #2 - 11 FOOT

X5.1 Prices for plows in quantities of

1-10	<u>7,532.<sup>00</sup></u>	per unit
11-20	<u>7,381.<sup>00</sup></u>	per unit
21-30	<u>7,233.<sup>00</sup></u>	per unit
31-40	<u>7,089.<sup>00</sup></u>	per unit
41-50	<u>6,947.<sup>00</sup></u>	per unit
51 and over	<u>6,808.<sup>00</sup></u>	per unit

X6.0 SPECIFICATIONS - GENERAL

X6.1 Manufacturer, model, series, and date of manufacture of proposed unit:

Henke 41R10IS WVOB

Is descriptive literature, fully describing proposed unit attached to your bid?  YES  NO

If not, why? \_\_\_\_\_

X6.2 Will the required number of service manuals, and complete parts list be delivered to the Equipment Division at Buckhannon upon completion of delivery of total units?

YES  NO

Will the required Equipment Preventive Maintenance Form (Section X6.2 of Bidders Evaluation Report) be provided upon inspection of the pilot unit?  YES  NO

EQUIPMENT PREVENTATIVE MAINTENANCE QUESTIONNAIRE

THIS FORM MUST BE COMPLETED IN ITS ENTIRETY BY SUCCESSFUL BIDDER OR MANUFACTURER'S TECHNICAL REPRESENTATIVE PRIOR TO DELIVERY OF PILOT MODEL TO THE WVDOH.

DESCRIPTION: Snow Plow MAKE: Henke  
MODEL: 412101S WV08 YEAR: 2 PURCHASE AMOUNT: \$ 7,532.00

ENGINE: MAKE: \_\_\_\_\_ MODEL: \_\_\_\_\_ FUEL TYPE: \_\_\_\_\_  
HORSEPOWER: \_\_\_\_\_ CYLINDER: \_\_\_\_\_ ENGINE SERIAL: \_\_\_\_\_  
COOLING SYSTEM CAPACITY: \_\_\_\_\_

BELTS: DESCRIPTION: \_\_\_\_\_ PART NUMBERS: \_\_\_\_\_  
\_\_\_\_\_  
\_\_\_\_\_

GVW: \_\_\_\_\_ AXLE CAPACITY: FRONT: \_\_\_\_\_ REAR: \_\_\_\_\_

TIRES: FRONT MAKE & SIZE: \_\_\_\_\_  
REAR MAKE & SIZE: \_\_\_\_\_

DIMENSIONS OF UNIT: LENGTH: \_\_\_\_\_ WIDTH: \_\_\_\_\_ LENGTH: \_\_\_\_\_

VENDOR CONTACT PERSON: \_\_\_\_\_ PHONE: \_\_\_\_\_

PARTS:  
BATTERY MAKE: \_\_\_\_\_ MODEL: \_\_\_\_\_ CCA: \_\_\_\_\_  
TOP OR SIDE POST: \_\_\_\_\_ DIMENSIONS: LENGTH \_\_\_\_\_ WIDTH \_\_\_\_\_ HEIGHT \_\_\_\_\_  
SPARK PLUGS OR FUEL INJECTORS MAKE: \_\_\_\_\_ PART # \_\_\_\_\_  
FUEL PUMP OR INJECTION PUMP MAKE: \_\_\_\_\_ MODEL: \_\_\_\_\_  
ALTERNATOR MAKE: \_\_\_\_\_ PART #: \_\_\_\_\_  
STARTER MAKE: \_\_\_\_\_ PART #: \_\_\_\_\_  
TURBO CHARGER MAKE: \_\_\_\_\_ PART #: \_\_\_\_\_  
TRANS. MAKE: \_\_\_\_\_ MODEL: \_\_\_\_\_ AUTO/MANUAL: \_\_\_\_\_  
HYDRAULIC PUMP MAKE: \_\_\_\_\_ MODEL: \_\_\_\_\_

FILTERS	MAKE	PART NO.	LUBRICANT	MANUFACTURER TYPE
OIL	_____	_____	ENGINE	_____
AIR INNER	_____	_____	TRANSMISSION	_____
AIR OUTER	_____	_____	POWER STEERING	_____
FUEL PRIMARY	_____	_____	HYDRAULIC	_____
FUEL SECONDARY	_____	_____	DIFFERENTIALS	_____
COOLANT	_____	_____	BRAKE FLUID	_____
HYDRAULIC	_____	_____	COOLANT	_____
OTHER	_____	_____	OTHER	_____

## X6.3 TRAINING:

Will training seminar be conducted on Preventive Maintenance, Operator and Mechanic Training  
 YES  NO

Will you conduct training with each purchase order against this open end contract?  
 YES  NO

Will training be conducted within 2 working days from the delivery of the pilot unit on the individual purchase order?  
 YES  NO

If NO, explain time frame \_\_\_\_\_

Will an Operator's Manual be furnished directly to Training Academy prior to the delivery of the pilot?  
 YES  NO

X6.4 If you are the successful vendor, will you furnish all training aids, i.e., videos, projectors, required in conducting the training?  
 YES  NO

X6.4.1 Will all manuals, booklets, etc. explaining preventive maintenance, operator procedures, and service schedule be delivered with each unit?  
 YES  NO  
 If NO, explain \_\_\_\_\_

## X6.5 WARRANTY AND SERVICE POLICY

Will the warranty and service you provide comply with all areas as stated in Section 6.5 of specifications  
 YES  NO

Is warranty literature attached?  
 YES  NO

Is a minimum two (2) year bumper to bumper basic parts and labor warranty included?  
 YES  NO

Describe:  
 \_\_\_\_\_  
 \_\_\_\_\_

Have you completed and submitted "Warranty and Service Policy Questionnaire" with your bid?  
 YES  NO

X6.5 WARRANTY AND SERVICE POLICY QUESTIONNAIRE

**THIS FORM MUST BE COMPLETED IN ITS ENTIRETY AND SUBMITTED WITH YOUR BID.**

(If additional lines are needed, make copies of form.)

1. Define the terms of the standard warranty. If not offered, so state. (Attach copy)

*see attached*

2. Define warranty service to be performed at DOH facilities and warranty service to be performed at manufacturer's representative facility. List name and location of manufacturer's representative.

*L.H. Jones Equipment Company  
Morgantown, WV 26505*

3. List locations for parts inventories that are within the State of West Virginia. Also, list availability levels, if known.

*L.H. Jones Equipment Company  
Morgantown, WV 26505*

4. During the term of warranty, list the guarantee discount to manufacturer's published list price for parts that bidder will sell the parts to owner.

- A. Terms: Net 30      Manufacturer's published list price less: 0 % discount
- B. Terms: Net 60      Manufacturer's published list price less: 0 % discount
- C. Terms: Net 90      Manufacturer's published list price less: 0 % discount

5. During the term of warranty, will all manufacturers or engineering improvements be submitted to Division of Highways?       YES     NO

6. During the term of warranty, list the guaranteed rates charged for repair to the unit.

- A. Shop Rate                      \$ \_\_\_\_\_ per mechanic hour
- B. Travel Time Charge            \$ \_\_\_\_\_ per mechanic hour  
(Specify if one-way)            \_\_\_\_\_; port to port \_\_\_\_\_
- C. Mileage Charge                \$ \_\_\_\_\_ per vehicle mile  
(Specify if one-way)            \_\_\_\_\_; port to port \_\_\_\_\_
- D. Field Mechanic Rate            \$ \_\_\_\_\_ per mechanic hour
- E. Specify period of time that prices are in effect: \_\_\_\_\_
- F. Surcharge for miscellaneous items: \_\_\_\_\_ %

*see attached  
warranty  
statement*

## X6.6 EVALUATION COMMITTEE REQUIREMENTS

Is all component specifications, product literature, component models provided for Evaluation Committee bid determination?  YES  NO

X6.7 Will all parts, equipment, accessories, material, design and performance characteristics not specified herein, but which are necessary to provide a complete unit, be furnished with the unit and conform in strength, quality of material, and quality of workmanship to those which are advertised and provided to the market in general by the unit industry?

YES  NO

X6.7.1 Are all parts and accessories adequate and regularly supplied as standard to be included except those which may be duplications of specifications herein, and except those by specification are not to be furnished?

YES  NO

X6.7.2 Are all standard safety features that are required by Federal and State statutes of law included?

YES  NO

## X7.0 SPECIFICATIONS OF THE QUOTED UNIT

The bidder should complete the following schedule in order for the Division to compare the actual bid unit to the specifications. Should the bidder except a requirement, then such exception may be only on the basis that such feature is not offered by the manufacturer. The Division will have the sole discretion as to whether the bidder's substitution meets the requirements of the specifications. by the manufacturer. The Division will have the sole discretion as to whether the bidder's substitution meets the requirements of the specifications.

Is the snowplow designed for mounting on a single axle or tandem dump truck  YES  NO

Is the snowplow capable of plowing to the right or left at an angle approximately 35° discharging to the right or left  YES  NO

Does it have a center mounted trip spring leaving the plow area outside the reversing arc free for nesting close to the pushing vehicle  YES  NO

Is it a straight blade type with an integral type snow shield  YES  NO

Will you supply the hose and fittings to connect both systems to the valve located under the front bumper  YES  NO

Is the blade section type, made up of three (3) and four (4) foot sections to total 10 feet or 11 feet wide, having a tungsten carbide inserted cutting edge  YES  NO

Manufacturer: Henke

Model: 41R10IS WVO8

X7.1 Moldboard:

X7.1.1 Overall Width:

X7.1.1.1 **OPTION #1** - 10 Foot  YES  NO

X7.1.1.2 **OPTION #2** - 11 Foot  YES  NO

X7.1.2 Overall height: 41 inches

X7.1.3 Moldboard construction: 10 U.S. Gauge

X7.1.4 Travel arc: 35 ° each way; total 70 °

X7.1.5 Radius from leading edge to deepest part of moldboard face 18 inches deep.

Cutting edge angle from vertical 27 degrees

X7.1.6 Weight of plow: 10 foot 1892 Lbs. 11 foot 1963 Lbs.

X7.1.7 Number of vertical ribs 8 Formed steel 1/2 x 4 tapered

How many ribs at each hinge point? (1) 1" reinforced

X7.1.8 Is an additional rubber snow shield provided?  YES  NO

Size of belting 3/8" Run entire length of plow?  YES  NO

Mounted so it won't add to overall height?  YES  NO

X7.1.9 Reinforcement constructed of steel and spaced per manufacturer's heavy duty design?

YES  NO

Number of vertical ribs: 8 Number of horizontal ribs: 3" x 3" angle reinforcement

X7.1.10 Reinforced at top and bottom edges?  YES  NO

Top of moldboard reinforced with integrally formed channel?  YES  NO

*top angle*

Bottom back up angle 4 x 4 x 3/4 angle gusseted.

X7.2 Cutting Edge:

X7.2.1 Sectioned, standard AASHO punched, in three (3) foot and four (4) foot lengths?

YES  NO

## X7.2.2 Blade Sections:

- X7.2.2.1 3/4 inch thick by 6 inches wide having a Grade WC cemented tungsten carbide insert of approximately 88 Rockwell A scale hardness?  YES  NO
- X7.2.2.2 Insert silver soldered on all sides of a milled slot near the center of the working edge?  YES  NO
- X7.2.2.3 Braze joint transverse rupture strength: 345+ PSI
- X7.2.2.4 Blade section identifiable by manufacturer, name and part number stamped on the reverse side of each section?  YES  NO
- X7.2.2.5 Will wrap around curb guards be mounted on right and left side of plow  YES  NO
- X7.2.2.6 Curb guards are 5/8 inch thick, 6 inches high and 8 inches long
- X7.3 Safety Trip Mechanism:
- X7.3.1 Tripping mechanism attached to trunnion on semi-circle and fully enclosed?  YES  NO  
 YES  NO
- X7.3.2 Are springs dual enclosed cylinder type trip springs?  YES  NO  
3/4 inch wire 5 3/8 inch diameter
- X7.3.3 Is tripping mechanism equipped with external cushion spring for absorbing shock?  YES  NO
- X7.3.4 Does the trip mechanism hold the plow rigid in plowing position and trip automatically when cutting edge comes in contact with an obstruction then returns to normal plowing position?  YES  NO
- X7.4 Push Frame:
- X7.4.1 All welded construction designed per manufacturer's heavy duty specifications?  YES  NO
- X7.4.2 Number of hinges in moldboard to push frame connection? (4)
- X7.4.3 Equipped with an oscillating feature to permit plow to follow uneven road surfaces?  YES  NO
- X7.4.3.1 Is push frame equipped with a quick hitch connection system?  YES  NO



## X7.4.4 Hydraulic Power Reversing Mechanism:

X7.4.4.1 Consist of two (2) double acting positive locking power reversing hydraulic cylinders fitted with the fixed base end in the center of the push frame?  YES  NO

X7.4.4.2 Cylinders four (4) inches inside diameter and piped to utilize power of both cylinders on every turn?  YES  NO

X7.4.4.3 Does hydraulic power reverse mechanism include a dual cross-over relief cushion valve?  
Rated at 20-30 GPM  YES  NO

## X7.4.5 Skid Shoes:

X7.4.5.1 Are caster mounted carbide mushroom type shoes included?  YES  NO

One on each side  YES  NO

X7.4.5.2 Manufacturer's standard adjusting mechanism included?  YES  NO

## X7.5 Hitch:

X7.5.1 Universal heavy duty type designed to carry plows of weight specified when mounted on a 32,000 pound class truck minimum?  YES  NO

X7.5.2 Bumper to axle type universally adaptable to any conventional truck and to accommodate a tilt front end on the carrier?  YES  NO

X7.5.2.1 Is hitch manufacturers quick hitch connection system for easy hook and unhook from plow push frame?  YES  NO

X7.5.2.2 Does hitch include a lift system  YES  NO

Designed at a rated capacity of 8K+ lbs.

## X7.5.3 Hitch to Bumper Attachment:

X7.5.3.1 Size of steel angle bolted to the channel bumper? 1/2 x 2 1/2 x 6 x 45

X7.5.3.2 Size of vertical flange on front of bumper? 6 Inches

Size of flange resting on top 2 1/2 Inches

X7.5.3.3 Ears or lugs welded to the vertical plane of the angle to facilitate attachment of the main body of the hitch?  YES  NO

X7.5.3.4 Axle end of hitch attached to the front axle by means of clamping arrangement?  YES  NO

X7.5.3.5 Axle clamp allows longitudinal motion but not vertical and horizontal motion?  
 YES  NO

X7.5.4 Are the horizontal and vertical frames constructed of four (4) inch structural steel "H" beams or equal and properly gusseted and welded?  
 YES  NO

X7.6 Hydraulic System:  
 Will you supply the following hydraulic components  YES  NO

X7.6.1 Provide one (1) 3" lift cylinder with 10" stroke double-acting hydraulic lift cylinder, clevis pinned top and bottom?  
 YES  NO

X7.6.2 Provide two (2) four (4) inch double acting hydraulic reversing cylinders?  
 YES  NO

X7.6.3 Provide three (3) pieces of two (2) wire hydraulic pressure hose one-quarter (1/4) inch diameter by approximately ten (10) feet long?  
 YES  NO

Is each hose equipped with the following  YES  NO

X7.6.3.1 Each hose equipped with one (1) quick coupler at plow end with dust cap?  
 YES  NO  
 Manufacturer/Model: Parker

X7.6.3.2 Each hose equipped with two (2) crimp-type fittings with male JIC 370 threads (one (1) to mate with swivel and the other to mate with quick coupler)?  YES  NO

X7.6.3.3 Each hose equipped with one (1) JIC 370 - swivel - 90°elbow/male JIC 370?  
 YES  NO

X7.6.3.4 Each hose equipped with one (1) adaptor to mate bank valve port to JIC swivel?  
 YES  NO

**X7.7 Other Standard Features:**

List other standard features offered and not addressed above:

---



---

X7.8 Does the proposed unit meet or exceed the OSHA of 1970 and/or subsequent changes?  
 YES  NO

X7.9 Is push frame and/or hitch assembly designed with regard to overall distance of truck to front of plow which would jeopardize truck balance?  
 YES  NO

X7.10 Paint:

X7.10.1 - X7.10.4 Describe proposed method of painting the unit: \_\_\_\_\_

shot blast, prime, paint

Will unit be ~~sandblasted~~ <sup>stadshot</sup> prior to painting?  YES  NO

X7.10.5 Paint and undercoat for push frame and hitch shot blast, prime, paint

Will push frame and hitch be completely covered  YES  NO

X7.11 Does the unit conform to the advertising guidelines?  YES  NO

X7.12 Will all loose hardware be in separate containers for each plow and be shipped with each plow?  YES  NO

STATE OF WEST VIRGINIA  
Purchasing Division

## PURCHASING AFFIDAVIT

**West Virginia Code §5A-3-10a states:** No contract or renewal of any contract may be awarded by the state or any of its political subdivisions to any vendor or prospective vendor when the vendor or prospective vendor or a related party to the vendor or prospective vendor is a debtor and the debt owed is an amount greater than one thousand dollars in the aggregate

### DEFINITIONS:

"Debt" means any assessment, premium, penalty, fine, tax or other amount of money owed to the state or any of its political subdivisions because of a judgment, fine, permit violation, license assessment, defaulted workers' compensation premium, penalty or other assessment presently delinquent or due and required to be paid to the state or any of its political subdivisions, including any interest or additional penalties accrued thereon.

"Debtor" means any individual, corporation, partnership, association, limited liability company or any other form or business association owing a debt to the state or any of its political subdivisions. "Political subdivision" means any county commission; municipality; county board of education; any instrumentality established by a county or municipality; any separate corporation or instrumentality established by one or more counties or municipalities, as permitted by law; or any public body charged by law with the performance of a government function or whose jurisdiction is coextensive with one or more counties or municipalities. "Related party" means a party, whether an individual, corporation, partnership, association, limited liability company or any other form or business association or other entity whatsoever, related to any vendor by blood, marriage, ownership or contract through which the party has a relationship of ownership or other interest with the vendor so that the party will actually or by effect receive or control a portion of the benefit, profit or other consideration from performance of a vendor contract with the party receiving an amount that meets or exceeds five percent of the total contract amount.

**EXCEPTION:** The prohibition of this section does not apply where a vendor has contested any tax administered pursuant to chapter eleven of this code, workers' compensation premium, permit fee or environmental fee or assessment and the matter has not become final or where the vendor has entered into a payment plan or agreement and the vendor is not in default of any of the provisions of such plan or agreement.

**LICENSING:** Vendors must be licensed and in good standing in accordance with any and all state and local laws and requirements by any state or local agency of West Virginia, including, but not limited to, the West Virginia Secretary of State's Office, the West Virginia Tax Department, West Virginia Insurance Commission, or any other state agencies or political subdivision. Furthermore, the vendor must provide all necessary releases to obtain information to enable the Director or spending unit to verify that the vendor is licensed and in good standing with the above entities.

**CONFIDENTIALITY:** The vendor agrees that he or she will not disclose to anyone, directly or indirectly, any such personally identifiable information or other confidential information gained from the agency, unless the individual who is the subject of the information consents to the disclosure in writing or the disclosure is made pursuant to the agency's policies, procedures and rules. Vendors should visit [www.state.wv.us/admin/purchase/privacy](http://www.state.wv.us/admin/purchase/privacy) for the Notice of Agency Confidentiality Policies.

Under penalty of law for false swearing (West Virginia Code, §61-5-3), it is hereby certified that the vendor acknowledges the information in this said affidavit and are in compliance with the requirements as stated.

Vendor's Name: Henke Manufacturing Corp.  
Authorized Signature: Michael Morris Date: 2/7/08

## **Henke Standard Warranty Policy**

Henke Manufacturing Corporation (HMC) warrants its products against defects in material and workmanship for a period of 24 months from date of delivery.

HMC, at its option will repair or replace any parts or components found to be defective in materials or workmanship.

Defects will be determined through photos provided by dealer or user, or through physical inspection of returned parts. Parts are to be returned freight prepaid when requested to HMC, labeled with a returned goods authorization number.

Authorization for warranty repair will be faxed to the reporting dealer, and will include labor hours that HMC agrees to credit the dealer, and the Return Goods Authorization Number, if applicable. Credit amounts for agreed labor hours will not exceed 70% of dealer shop selling rate. Mileage, travel time, overtime, or any incidental costs will not be included in warranty consideration. Credits will apply to current or future business with HMC.

This warranty does not include normal wear items such as cutting edges, wear guards, scarifier teeth, etc. Repairs required as a result of misapplication, accidental damage, improper maintenance, improper installation, or negligence are also not covered by warranty.

HMC warranty for any purchased components, such as hydraulic cylinders will be superceded by, and equal to the component manufacturer warranty.

SELLER IS NOT, UNDER ANY CIRCUMSTANCE, LIABLE FOR ANY INCIDENTAL, CONSEQUENTIAL OR PUNITIVE DAMAGES. SELLER EXPRESSLY DISCLAIMS AND EXCLUDES ALL IMPLIED WARRANTIES, INCLUDING ANY WARRANTY OR MERCHANTABILITY OR FITNESS FOR A PARTICULAR PURPOSE.

# HENKE

Henke Manufacturing Corporation

Made in the USA  
For Over 90 Years

## "iPlow" Reversible Truck Mounted Snowplows

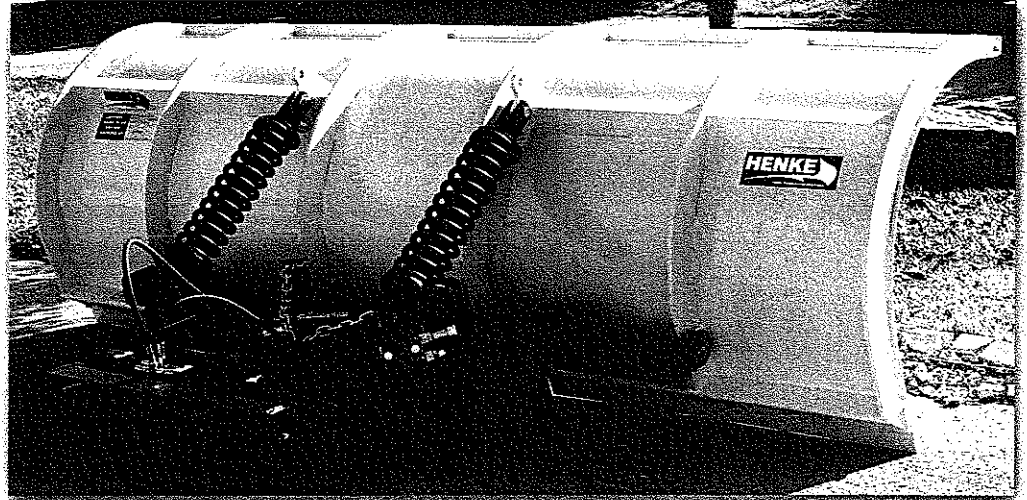

### Variety of Optional Running Gear

SPRING LOADED  
RUNNING GEAR

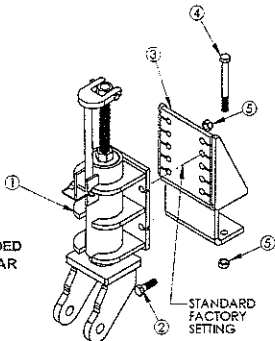

STANDARD  
FACTORY  
SETTING

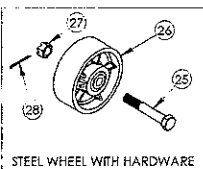

STEEL WHEEL WITH HARDWARE

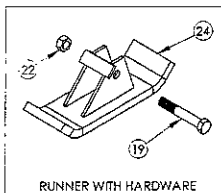

RUNNER WITH HARDWARE

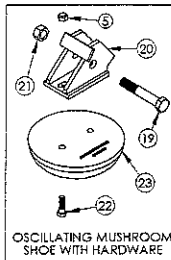

OSCILLATING MUSHROOM  
SHOE WITH HARDWARE

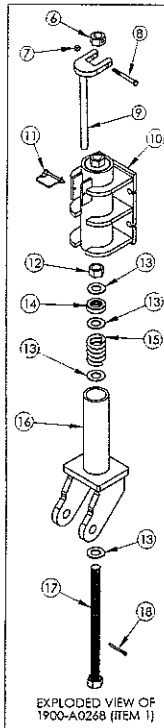

EXPLODED VIEW OF  
1900-A0268 (ITEM 1)

### 3GR10IS "iPlow" Dual External Compression Spring Trip

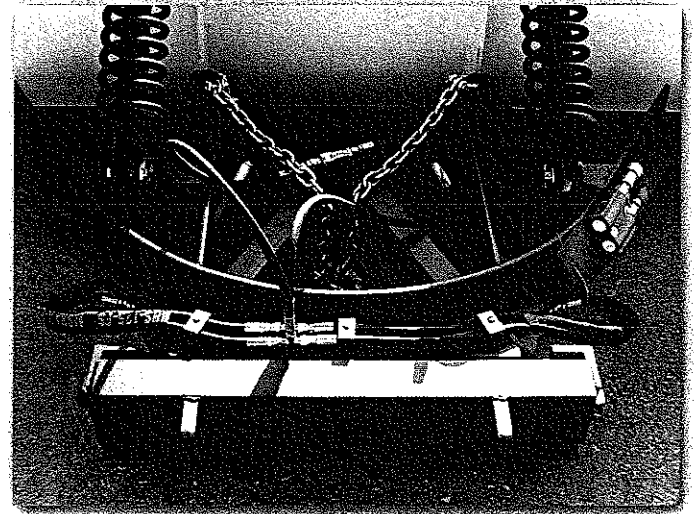

- Available in a Wide Range of Sizes and Configurations
- Multiple Trip, Hitch, and Running Gear Options Available
- "Integral Snow Shield" Prevents Snow from Blowing Over Top of Plow Moldboard
- Double Acting Dual Reversing Hydraulic Cylinders
- Serviceable Chevron Style V-Gland Packed Cylinders
- Cutting Edge Conforms to AASTHO Punch Pattern

### Product Features:

- Available Lengths: 10', 11', 12'
- Moldboard Heights: 36", 41", 48"
- 3/16" Rolled Plate Steel
- 3 1/2" x 3 1/2" x 1/2" Steel Circle Frame w/Positive Stops

# Built Tough – Built to Last!

3070 Wilson • Leavenworth, KS 66048 • (913) 682-9000 • Fax (913) 682-0300

www.henkemfg.com • Toll Free 888-682-9010

# HENKE

Henke Manufacturing Corporation

Made in the USA  
For Over 80 Years

## Henke Truck Hitches

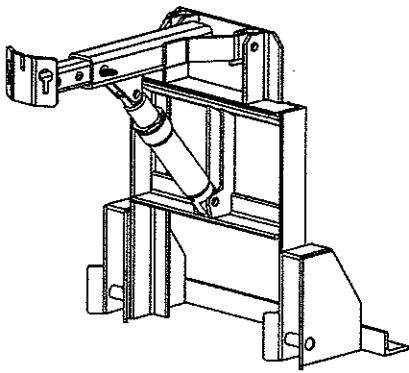

UQH - Universal Quick Hitch ▲

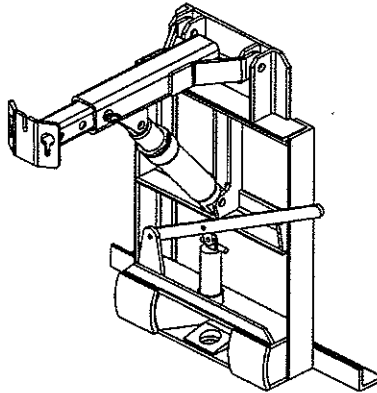

QCP - Low Profile QCP Loop ▲

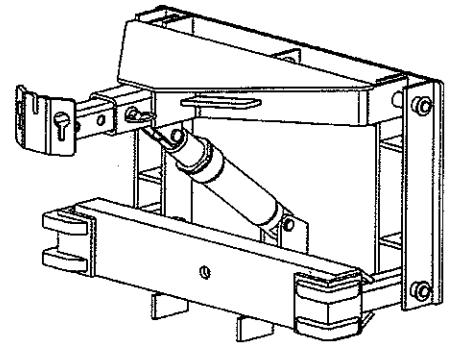

DIN Hitch - Low Profile Bumper Hitch ▲

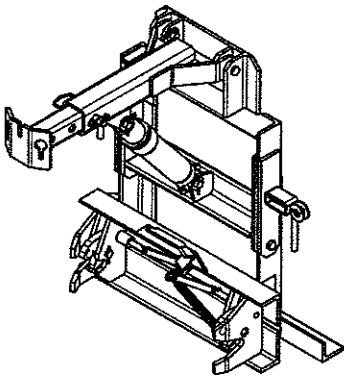

QL-LP - Quick Link Low Profile ▲

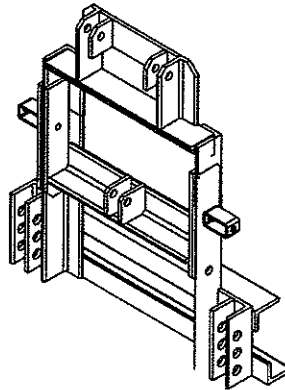

UH-LP-T - Universal Hitch Low Profile w/ Tilt ▲

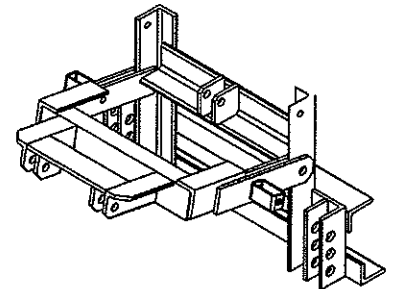

Low Profile Bumper to Axle Hitch ▼

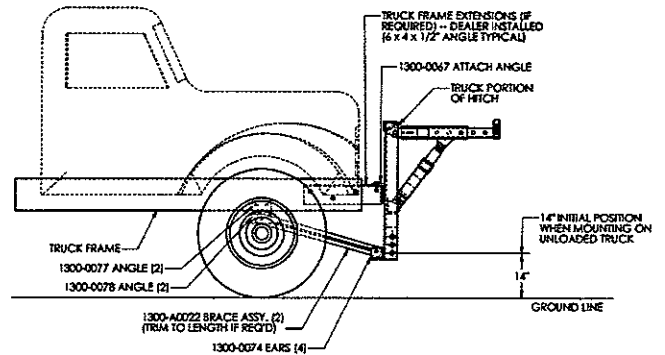
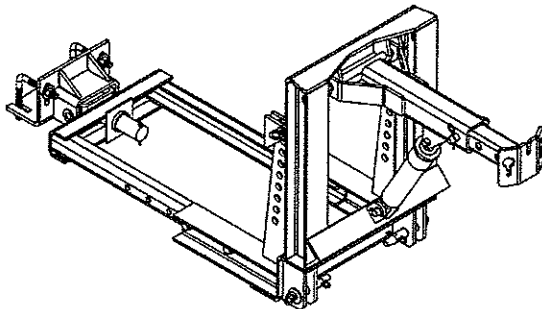

Additional Truck Hitch options available for custom installations.

# Built Tough - Built to Last!

## **Henke Reversible Snowplow Specifications**

### **41R11IS Moldboard**

Moldboard shall be composed of smooth rolled 3/16" x 55" x 11ft steel plate welded to a minimum of (6) 1/2" x 4" curved vertical ribs. The ribs shall be plasma cut and tapered, with the top end welded to a 2" x 3" x 3/8" moldboard top angle, and the bottom end welded to a 1" thick steel bottom rib pivot reinforcement. This pivot reinforcement is to be welded to a 4" x 4" x 5/8" bottom angle. The bottom angle shall be reinforced with gussets between the cutting edge mount holes. The moldboard shall have an integral shield, which will constitute the moldboard face extending to approximately 19" forward of the cutting edge at a consistent radius. Moldboard height shall be 41" with an 8" cutting edge and full moldboard trip.

### **Circle Pushframe**

The pushframe shall consist of a circle frame and pushbeam. The circle frame shall consist of a 3 1/2" x 3 1/2" x 1/2" steel angle rolled in an arc spanning 66", with two support legs each of 3 1/2" x 3 1/2" x 1/2", 27 1/2" long which are welded between the circle-frame and the pushbeam. The pushbeam shall be composed of 4" x 4" x 3/8" square steel tube, 85 1/2" long. Eight ears of 1/2" thick steel will be welded to the pushbeam for attaching to the moldboard at four of the bottom rib pivot reinforcements. The ears will be drilled to accept 1 1/4" pivot pins.

### **A-Frame**

The A-frame will be constructed of 4" ship channel, welded to a 1" x 5" backplate. A 5/8" x 3 1/2" x 25" top plate welded to the A-frame serves as the circle frame hold down. The A-frame attaches to the circle assembly with a 1 1/4" grade 5 bolt installed through (2) 1/2" thick ears welded to the A-frame.

### **Moldboard Trip**

Moldboard Trip shall be an enclosed spring trip type. The enclosed spring trip consists of an outer housing, (2) inner compression springs, inner guide tube, inner shaft, rebound spring and trunion mount. The (outside) inner compression spring shall be 5 3/8" in diameter, 19 7/8" long, of 3/4" wire, rated at 3,275lbs maximum compression. The (inside) inner compression spring shall be 3 3/8" in diameter, 19 5/8" long of 5/8" wire, rated at 3,300lbs maximum compression. Both springs shall be pre-stressed to approximately 1,100lbs. The inner shaft shall be 1 3/8" CR steel. The shaft end will be drilled to accept a 1" diameter moldboard connecting bolt. The rebound spring (located between the shaft end and the inner tube on the inner shaft) shall be 2 7/8" in diameter, 2 5/8" long, of 3/4" wire, rated at 9,280lbs maximum compression. The enclosed spring trip assembly shall require a force of 6,600lbs to fully compress both inner springs.



**Paint**

The plow shall be sand blasted according to commercial blast cleaning (SSPC-SP 6) to a white metal surface prior to priming and painting.