



---

1825 Earl Core Road  
Morgantown WV 26505  
Local Phone: 304-292-1307  
Toll Free: 888-292-1305  
Fax: 304-292-6641  
[www.lhjones.com](http://www.lhjones.com)

November 19, 2007

Mr. Michael Austin  
State of West Virginia  
Department of Administration  
Purchasing Division  
2019 Washington Street East  
P.O. Box 50130  
Charleston, WV 25305-0130

Dear Mr. Austin:

The attached/enclosed response to RFQ# 708EC004 replaces any and all documents previously submitted in response to RFQ# 708EC004. All previously submitted documents must be disregarded. Please return previously submitted documents to LH Jones Equipment Company if permitted.

If you have any questions or require additional information, please do not hesitate to contact me at your convenience.

Regards,

A handwritten signature in black ink, appearing to read 'LH', is written over a white background.

Leonard "Len" Hancock Jr.  
Vice President



State of West Virginia  
 Department of Administration  
 Purchasing Division  
 2019 Washington Street East  
 Post Office Box 50130  
 Charleston, WV 25305-0130

# Request for Quotation

RFQ NUMBER  
**708EC004**

PAGE  
**1**

ADDRESS CORRESPONDENCE TO ATTENTION OF  
**JOHN JOHNSTON**  
**304-558-2402**

RFQ COPY  
 TYPE NAME/ADDRESS HERE

V  
E  
N  
D  
O  
R

**LH Jones Equipment Co.**  
**1825 SARE CONC Rd.**  
**Morgantown, WV 26505**

S  
H  
I  
P  
T  
O

**DIVISION OF HIGHWAYS**  
**EQUIPMENT DIVISION**  
**ROUTE 33**  
**BRUSHY FORK ROAD**  
**BUCKHANNON, WV**  
**26201**      **304-472-1750**

DATE PRINTED	TERMS OF SALE	SHIP VIA	FOB	FREIGHT TERMS
09/24/2007	Net 30 Days	Motor Freight	Buckhannon, WV	No Charge
BID OPENING DATE: 11/13/2007		BID OPENING TIME 01:30PM		

LINE	QUANTITY	UOP	CAT NO	ITEM NUMBER	UNIT PRICE	AMOUNT
0001	1	EA		765-66	See Page 22	
<p>FIVE CUBIC YARD STAINLESS STEEL (HYDRAULIC) SPREADER</p> <p>OPEN END CONTRACT</p> <p>TO PROVIDE 5 CUBIC YARD STAINLESS STEEL DEMOUNTABLE ABRASIVE AND CHEMICAL SPREADER (HYDRAULIC) AS DESCRIBED IN THE ATTACHED SPECIFICATIONS 012-1-2.</p> <p>THERE WILL BE A MANDATORY PRE-BID CONFERENCE AT THE STATE CAPITOL COMPLEX, BUILDING 15, CONFERENCE ROOM, AT 10:00 AM ON 10/26/2007. FAILURE TO ATTEND THE PRE-BID CONFERENCE WILL RESULT IN BID DISQUALIFICATION</p> <p>QUESTIONS: WRITTEN QUESTIONS WILL BE ACCEPTED THROUGH CLOSE OF BUSINESS (5:00 PM EST) ON TUESDAY, 10/16/07. SEND YOUR QUESTIONS TO: PURCHASING DIVISION          ATTENTION MICHAEL AUSTIN          2019 WASHINGTON ST. E.          CHARLESTON, WV. 25305</p> <p>QUESTIONS MAY BE SENT VIA FAX, E-MAIL, OR REGULAR MAIL.          E-MAIL: MAUSTIN@WVADMIN.GOV          FAX: 304-558-4115</p> <p>IT IS THE VENDORS RESPONSIBILITY TO VERIFY THAT THEIR QUESTIONS HAVE BEEN RECEIVED BY CALLING 304-558-2316.</p> <p>EXHIBIT 2</p> <p>LIFE OF CONTRACT: THIS CONTRACT BECOMES EFFECTIVE ON</p>						

SEE REVERSE SIDE FOR TERMS AND CONDITIONS

SIGNATURE *[Signature]* TELEPHONE **304 792 1307** DATE **11/14/07**  
 TITLE **VP** FEIN **55-0551865** ADDRESS CHANGES TO BE NOTED ABOVE

WHEN RESPONDING TO RFQ, INSERT NAME AND ADDRESS IN SPACE ABOVE LABELED 'VENDOR'

**GENERAL TERMS & CONDITIONS  
REQUEST FOR QUOTATION (RFQ) AND REQUEST FOR PROPOSAL (RFP)**

1. Awards will be made in the best interest of the State of West Virginia
2. The State may accept or reject in part, or in whole, any bid
3. All quotations are governed by the *West Virginia Code* and the *Legislative Rules* of the Purchasing Division
4. Prior to any award, the apparent successful vendor must be properly registered with the Purchasing Division and have paid the required \$125.00 registration fee.
5. All services performed or goods delivered under State Purchase Orders/Contracts are to be continued for the term of the Purchase Order/Contract, contingent upon funds being appropriated by the Legislature or otherwise being made available. In the event funds are not appropriated or otherwise available for these services or goods, this Purchase Order/Contract becomes void and of no effect after June 30
6. Payment may only be made after the delivery and acceptance of goods or services.
7. Interest may be paid for late payment in accordance with the *West Virginia Code*.
8. Vendor preference will be granted upon written request in accordance with the *West Virginia Code*.
9. The State of West Virginia is exempt from federal and state taxes and will not pay or reimburse such taxes.
10. The Director of Purchasing may cancel any Purchase Order/Contract upon 30 days written notice to the seller.
11. The laws of the State of West Virginia and the *Legislative Rules* of the Purchasing Division shall govern all rights and duties under the Contract, including without limitation the validity of this Purchase Order/Contract
12. Any reference to automatic renewal is hereby deleted. The Contract may be renewed only upon mutual written agreement of the parties.
13. **BANKRUPTCY:** In the event the vendor/contractor files for bankruptcy protection, this contract is automatically null and void, and is terminated without further order.
14. **HIPAA Business Associate Addendum** - The West Virginia State Government HIPAA Business Associate Addendum (BAA), approved by the Attorney General, and available online at the Purchasing Division's web site (<http://www.state.wv.us/admin/purchase/vrc/hipaa.htm>) is hereby made part of the agreement. Provided that, the Agency meets the definition of a Covered Entity (45 CFR §160.103) and will be disclosing Protected Health Information (45 CFR §160.103) to the vendor

---

**INSTRUCTIONS TO BIDDERS**

1. Use the quotation forms provided by the Purchasing Division
2. **SPECIFICATIONS:** Items offered must be in compliance with the specifications. Any deviation from the specifications must be clearly indicated by the bidder. Alternates offered by the bidder as **EQUAL** to the specifications must be clearly defined. A bidder offering an alternate should attach complete specifications and literature to the bid. The Purchasing Division may waive minor deviations to specifications.
3. Complete all sections of the quotation form.
4. Unit prices shall prevail in cases of discrepancy.
5. All quotations are considered F.O.B. destination unless alternate shipping terms are clearly identified in the quotation
6. **BID SUBMISSION:** All quotations must be delivered by the bidder to the office listed below prior to the date and time of the bid opening. Failure of the bidder to deliver the quotations on time will result in bid disqualifications.

**SIGNED BID TO:**

Department of Administration  
Purchasing Division  
2019 Washington Street East  
Post Office Box 50130  
Charleston, WV 25305-0130



State of West Virginia  
 Department of Administration  
 Purchasing Division  
 2019 Washington Street East  
 Post Office Box 50130  
 Charleston, WV 25305-0130

# Request for Quotation

RFQ NUMBER  
 708EC004

PAGE  
 2

ADDRESS CORRESPONDENCE TO ATTENTION OF  
 JOHN JOHNSTON  
 304-558-2402

RFQ COPY  
 TYPE NAME/ADDRESS HERE

SUBJECT

SHIP TO

DIVISION OF HIGHWAYS  
 EQUIPMENT DIVISION  
 ROUTE 33  
 BRUSHY FORK ROAD  
 BUCKHANNON, WV  
 26201 304-472-1750

DATE PRINTED	TERMS OF SALE	SHIP VIA	F.O.B.	FREIGHT TERMS
09/24/2007				

BID OPENING DATE: 11/13/2007 BID OPENING TIME 01:30PM

LINE	QUANTITY	UOP	CAT NO	ITEM NUMBER	UNIT PRICE	AMOUNT
<p>..... AND EXTENDS FOR A PERIOD OF ONE (1) YEAR OR UNTIL SUCH "REASONABLE TIME" THEREAFTER AS IS NECESSARY TO OBTAIN A NEW CONTRACT OR RENEW THE ORIGINAL CONTRACT. THE "REASONABLE TIME" PERIOD SHALL NOT EXCEED TWELVE (12) MONTHS. DURING THIS "REASONABLE TIME" THE VENDOR MAY TERMINATE THIS CONTRACT FOR ANY REASON UPON GIVING THE DIRECTOR OF PURCHASING THIRTY (30) DAYS WRITTEN NOTICE.</p> <p>UNLESS SPECIFIC PROVISIONS ARE STIPULATED IN THIS CONTRACT DOCUMENT, THE TERMS, CONDITIONS, AND PRICING SET HEREIN ARE FIRM FOR THE LIFE OF THE CONTRACT.</p> <p>RENEWAL: THIS CONTRACT MAY BE RENEWED UPON THE MUTUAL WRITTEN CONSENT OF THE SPENDING UNIT AND VENDOR, SUBMITTED TO THE DIRECTOR OF PURCHASING THIRTY (30) DAYS PRIOR TO THE EXPIRATION DATE. SUCH RENEWAL SHALL BE IN ACCORDANCE WITH THE TERMS AND CONDITIONS OF THE ORIGINAL CONTRACT AND SHALL BE LIMITED TO TWO (2) ONE (1) YEAR PERIODS.</p> <p>CANCELLATION: THE DIRECTOR OF PURCHASING RESERVES THE RIGHT TO CANCEL THIS CONTRACT IMMEDIATELY UPON WRITTEN NOTICE TO THE VENDOR IF THE COMMODITIES AND/OR SERVICE SUPPLIED ARE OF AN INFERIOR QUALITY OR DO NOT CONFORM WITH THE SPECIFICATIONS OF THE BID AND CONTRACT HEREIN.</p> <p>OPEN MARKET CLAUSE: THE DIRECTOR OF PURCHASING MAY AUTHORIZE A SPENDING UNIT TO PURCHASE ON THE OPEN MARKET, WITHOUT THE FILING OF A REQUISITION OR COST ESTIMATE, ITEMS SPECIFIED ON THIS CONTRACT FOR IMMEDIATE DELIVERY IN EMERGENCIES DUE TO UNFORESEEN CAUSES (INCLUDING BUT NOT LIMITED TO DELAYS IN TRANSPORTATION OR AN UNANTICIPATED INCREASE IN THE VOLUME OF WORK).</p> <p>QUANTITIES: QUANTITIES LISTED IN THE REQUISITION ARE</p>						

SEE REVERSE SIDE FOR TERMS AND CONDITIONS

SIGNATURE	TELEPHONE	DATE
TITLE	FEIN	ADDRESS CHANGES TO BE NOTED ABOVE

WHEN RESPONDING TO RFQ, INSERT NAME AND ADDRESS IN SPACE ABOVE LABELED 'VENDOR'



State of West Virginia  
 Department of Administration  
 Purchasing Division  
 2019 Washington Street East  
 Post Office Box 50130  
 Charleston, WV 25305-0130

# Request for Quotation

RFQ NUMBER:  
 708EC004

PAGE:  
 3

ADDRESS CORRESPONDENCE TO ATTENTION OF:  
 JOHN JOHNSTON  
 304-558-2402

RFQ COPY  
 TYPE NAME/ADDRESS HERE

VENDOR

SUPPLIER

DIVISION OF HIGHWAYS  
 EQUIPMENT DIVISION  
 ROUTE 33  
 BRUSHY FORK ROAD  
 BUCKHANNON, WV  
 26201 304-472-1750

DATE PRINTED	TERMS OF SALE	SHIP VIA	F.O.B.	FREIGHT TERMS
09/24/2007				

BID OPENING DATE: 11/13/2007 BID OPENING TIME 01:30PM

LINE	QUANTITY	UOP	CAT. NO.	ITEM NUMBER	UNIT PRICE	AMOUNT
<p>APPROXIMATIONS ONLY, BASED ON ESTIMATES SUPPLIES BY THE STATE SPENDING UNIT. IT IS UNDERSTOOD AND AGREED THAT THE CONTRACT SHALL COVER THE QUANTITIES ACTUALLY ORDERED FOR DELIVERY DURING THE TERM OF CONTRACT, WHETHER MORE OR LESS THAN THE QUANTITIES SHOWN.</p> <p>ORDERING PROCEDURE: SPENDING UNIT(S) SHALL ISSUE A WRITTEN EQUIPMENT CONTRACT ORDER (FORM NUMBER WV-35) FOR COMMODITIES COVERED BY THIS CONTRACT. THE ORIGINAL WV-35 MUST BE SENT TO THE PURCHASING DIVISION OF THE DEPARTMENT OF ADMINISTRATION. AFTER APPROVAL AND ENCUMBRANCE, ONE COPY OF THE PURCHASE ORDER WILL BE RETURNED TO THE SPENDING UNIT AND ONE COPY FORWARDED TO THE VENDOR AS AUTHORIZATION FOR SHIPMENT. NO ORDER IS VALID UNLESS APPROVED AND ENCUMBERED BY THE PURCHASING DIVISION.</p> <p>BANKRUPTCY: IN THE EVENT THE VENDOR/CONTRACTOR FILES FOR BANKRUPTCY PROTECTION, THIS CONTRACT IS AUTOMATICALLY NULL AND VOID, AND IS TERMINATED WITHOUT FURTHER ORDER.</p> <p>EXHIBIT 6</p> <p>PRICE ADJUSTMENT PROVISION:          THE STATE OF WEST VIRGINIA WILL CONSIDER BIDS THAT CONTAIN PROVISIONS FOR PRICE ADJUSTMENTS PRIOR TO THE ORIGINAL EXPIRATION OF THE CONTRACT, PROVIDED THAT SUCH PRICE ADJUSTMENT COVERS BOTH UPWARD AND DOWNWARD MOVEMENT OF THE COMMODITY PRICE, AND THAT ADJUSTMENT IS BASED ON THE "PASS THROUGH" INCREASE OR DECREASE OF RAW MATERIALS AND/OR LABOR, WHICH MAKE UP ALL OR A SUBSTANTIAL PART OF A PRODUCT. ADJUSTMENTS ARE TO BE BASED UPON AN ACTUAL DOLLAR FIGURE, NOT A PERCENTAGE. ALL PRICE ADJUSTMENT REQUESTS MUST BE SUBSTANTIATED IN</p>						

SEE REVERSE SIDE FOR TERMS AND CONDITIONS

SIGNATURE	TELEPHONE	DATE
TITLE	FEIN	ADDRESS CHANGES TO BE NOTED ABOVE

WHEN RESPONDING TO RFQ, INSERT NAME AND ADDRESS IN SPACE ABOVE LABELED 'VENDOR'



State of West Virginia  
 Department of Administration  
 Purchasing Division  
 2019 Washington Street East  
 Post Office Box 50130  
 Charleston, WV 25305-0130

# Request for Quotation

RFQ NUMBER  
**708EC004**

PAGE  
**4**

ADDRESS CORRESPONDENCE TO ATTENTION OF  
**JOHN JOHNSTON  
 304-558-2402**

PROPERTY

RFQ COPY  
 TYPE NAME/ADDRESS HERE

SHIP TO

DIVISION OF HIGHWAYS  
 EQUIPMENT DIVISION  
 ROUTE 33  
 BRUSHY FORK ROAD  
 BUCKHANNON, WV  
 26201 304-472-1750

DATE PRINTED	TERMS OF SALE	SHIP VIA	F.O.B.	FREIGHT TERMS
09/24/2007				

BID OPENING DATE: **11/13/2007** BID OPENING TIME **01:30PM**

LINE	QUANTITY	UOP	CAT NO	ITEM NUMBER	UNIT PRICE	AMOUNT
<p>A MANNER ACCEPTABLE TO THE DIRECTOR PURCHASING, E.G. GOVERNMENTAL BENCH MARKS, GENERAL MARKET INCREASE, PUBLISHED PRICE LISTS. SUCH REQUESTS FOR AND INCREASE SHOULD BE RECEIVED IN WRITING BY THE DIRECTOR OF PURCHASING AT LEAST 30 DAYS IN ADVANCE OF THE EFFECTIVE DATE OF THE INCREASE. ANY TIME THE VENDOR REQUESTS A PRICE ADJUSTMENT, THE PURCHASING DIVISION MAY EITHER ACCEPT THE PRICE ADJUSTMENT AND AMEND THE CONTRACT ACCORDINGLY OR REJECT THE ADJUSTMENT IN ITS ENTIRETY AND CANCEL THE CONTRACT.</p> <p>EXHIBIT 4</p> <p>LOCAL GOVERNMENT BODIES: UNLESS THE VENDOR INDICATES IN THE BID HIS REFUSAL TO EXTEND THE PRICES, TERMS, AND CONDITIONS OF THE BID TO COUNTY, SCHOOL, MUNICIPAL AND OTHER LOCAL GOVERNMENT BODIES, THE BID SHALL EXTEND TO POLITICAL SUBDIVISIONS OF THE STATE OF WEST VIRGINIA. IF THE VENDOR DOES NOT WISH TO EXTEND THE PRICES, TERMS, AND CONDITIONS OF THE BID TO ALL POLITICAL SUBDIVISIONS OF THE STATE, THE VENDOR MUST CLEARLY INDICATE SUCH REFUSAL IN HIS BID. SUCH REFUSAL SHALL NOT PREJUDICE THE AWARD OF THIS CONTRACT IN ANY MANNER.</p> <p>REV. 3/88</p> <p>VENDOR PREFERENCE CERTIFICATE</p> <p>CERTIFICATION AND APPLICATION* IS HEREBY MADE FOR PREFERENCE IN ACCORDANCE WITH WEST VIRGINIA CODE, 5A-3-37 (DOES NOT APPLY TO CONSTRUCTION CONTRACTS).</p> <p>A. APPLICATION IS MADE FOR 2.5% PREFERENCE FOR THE</p>						

SEE REVERSE SIDE FOR TERMS AND CONDITIONS

SIGNATURE	TELEPHONE	DATE
TITLE	FEIN	ADDRESS CHANGES TO BE NOTED ABOVE

WHEN RESPONDING TO RFQ, INSERT NAME AND ADDRESS IN SPACE ABOVE LABELED 'VENDOR'



State of West Virginia  
 Department of Administration  
 Purchasing Division  
 2019 Washington Street East  
 Post Office Box 50130  
 Charleston, WV 25305-0130

# Request for Quotation

RFQ NUMBER:  
 708EC004

PAGE:  
 5

ADDRESS CORRESPONDENCE TO ATTENTION OF:  
 JOHN JOHNSTON  
 304-558-2402

RFQ COPY  
 TYPE NAME/ADDRESS HERE

VENDOR

SHIP TO

DIVISION OF HIGHWAYS  
 EQUIPMENT DIVISION  
 ROUTE 33  
 BRUSHY FORK ROAD  
 BUCKHANNON, WV  
 26201 304-472-1750

DATE PRINTED	TERMS OF SALE	SHIP VIA	F.O.B.	FREIGHT TERMS
09/24/2007				

BID OPENING DATE: 11/13/2007 BID OPENING TIME 01:30PM

LINE	QUANTITY	UOP	CAT NO	ITEM NUMBER	UNIT PRICE	AMOUNT
<p>REASON CHECKED:</p> <p>( ) BIDDER IS AN INDIVIDUAL RESIDENT VENDOR AND HAS RESIDED CONTINUOUSLY IN WEST VIRGINIA FOR FOUR (4) YEARS IMMEDIATELY PRECEDING THE DATE OF THIS CERTIFICATION; OR</p> <p>(X) BIDDER IS A PARTNERSHIP, ASSOCIATION OR CORPORATION RESIDENT VENDOR AND HAS MAINTAINED ITS HEAD-QUARTERS OR PRINCIPAL PLACE OF BUSINESS CONTINUOUSLY IN WEST VIRGINIA FOR FOUR (4) YEARS IMMEDIATELY PRECEDING THE DATE OF THIS CERTIFICATION; OR 80% OF THE OWNERSHIP INTEREST OF BIDDER IS HELD BY ANOTHER INDIVIDUAL, PARTNERSHIP, ASSOCIATION OR CORPORATION RESIDENT VENDOR WHO HAS MAINTAINED ITS HEADQUARTERS OR PRINCIPAL PLACE OF BUSINESS CONTINUOUSLY IN WEST VIRGINIA FOR FOUR (4) YEARS IMMEDIATELY PRECEDING THE DATE OF THIS CERTIFICATION; OR</p> <p>( ) BIDDER IS A CORPORATION NONRESIDENT VENDOR WHICH HAS AN AFFILIATE OR SUBSIDIARY WHICH EMPLOYS A MINIMUM OF ONE HUNDRED STATE RESIDENTS AND WHICH HAS MAINTAINED ITS HEADQUARTERS OR PRINCIPAL PLACE OF BUSINESS WITHIN WEST VIRGINIA CONTINUOUSLY FOR THE FOUR (4) YEARS IMMEDIATELY PRECEDING THE DATE OF THIS CERTIFICATION.</p> <p>B. APPLICATION IS MADE FOR 2.5% PREFERENCE FOR THE REASON CHECKED:</p> <p>( ) BIDDER IS A RESIDENT VENDOR WHO CERTIFIES THAT, DURING THE LIFE OF THE CONTRACT, ON AVERAGE AT LEAST 75% OF THE EMPLOYEES WORKING ON THE PROJECT BEING BID ARE RESIDENTS OF WEST VIRGINIA WHO HAVE RESIDED IN THE STATE CONTINUOUSLY FOR THE TWO YEARS IMMEDIATELY PRECEDING SUBMISSION OF THIS BID;</p>						

SEE REVERSE SIDE FOR TERMS AND CONDITIONS

SIGNATURE	TELEPHONE	DATE
TITLE	FEIN	ADDRESS CHANGES TO BE NOTED ABOVE

WHEN RESPONDING TO RFQ, INSERT NAME AND ADDRESS IN SPACE ABOVE LABELED 'VENDOR'



State of West Virginia  
 Department of Administration  
 Purchasing Division  
 2019 Washington Street East  
 Post Office Box 50130  
 Charleston, WV 25305-0130

**Request for  
 Quotation**

RFQ NUMBER  
 708EC004

PAGE  
 6

ADDRESS CORRESPONDENCE TO ATTENTION OF  
 JOHN JOHNSTON  
 304-558-2402

RFQ COPY  
 TYPE NAME/ADDRESS HERE

VENDOR

SHIP TO

DIVISION OF HIGHWAYS  
 EQUIPMENT DIVISION  
 ROUTE 33  
 BRUSHY FORK ROAD  
 BUCKHANNON, WV  
 26201 304-472-1750

DATE PRINTED	TERMS OF SALE	SHIP VIA	FOB	FREIGHT TERMS
09/24/2007				

BID OPENING DATE: 11/13/2007 BID OPENING TIME 01:30PM

LINE	QUANTITY	UOP	CAT NO	ITEM NUMBER	UNIT PRICE	AMOUNT
<p>OR            ( ) BIDDER IS A NONRESIDENT VENDOR EMPLOYING A MINIMUM OF ONE HUNDRED STATE RESIDENTS OR IS A NONRESIDENT VENDOR WITH AN AFFILIATE OR SUBSIDIARY WHICH MAINTAINS ITS HEADQUARTERS OR PRINCIPAL PLACE OF BUSINESS WITHIN WEST VIRGINIA EMPLOYING A MINIMUM OF ONE HUNDRED STATE RESIDENTS WHO CERTIFIES THAT, DURING THE LIFE OF THE CONTRACT, ON AVERAGE AT LEAST 75% OF THE EMPLOYEES OR BIDDERS' AFFILIATE'S OR SUBSIDIARY'S EMPLOYEES ARE RESIDENTS OF WEST VIRGINIA WHO HAVE RESIDED IN THE STATE CONTINUOUSLY FOR THE TWO YEARS IMMEDIATELY PRECEDING SUBMISSION OF THIS BID.</p> <p>BIDDER UNDERSTANDS IF THE SECRETARY OF TAX &amp; REVENUE DETERMINES THAT A BIDDER RECEIVING PREFERENCE HAS FAILED TO CONTINUE TO MEET THE REQUIREMENTS FOR SUCH PREFERENCE, THE SECRETARY MAY ORDER THE DIRECTOR OF PURCHASING TO: (A) RESCIND THE CONTRACT OR PURCHASE ORDER ISSUED; OR (B) ASSESS A PENALTY AGAINST SUCH BIDDER IN AN AMOUNT NOT TO EXCEED 5% OF THE BID AMOUNT AND THAT SUCH PENALTY WILL BE PAID TO THE CONTRACTING AGENCY OR DEDUCTED FROM ANY UNPAID BALANCE ON THE CONTRACT OR PURCHASE ORDER.</p> <p>BY SUBMISSION OF THIS CERTIFICATE, BIDDER AGREES TO DISCLOSE ANY REASONABLY REQUESTED INFORMATION TO THE PURCHASING DIVISION AND AUTHORIZES THE DEPARTMENT OF TAX AND REVENUE TO DISCLOSE TO THE DIRECTOR OF PURCHASING APPROPRIATE INFORMATION VERIFYING THAT BIDDER HAS PAID THE REQUIRED BUSINESS TAXES, PROVIDED THAT SUCH INFORMATION DOES NOT CONTAIN THE AMOUNTS OF TAXES PAID NOR ANY OTHER INFORMATION DEEMED BY THE TAX COMMISSIONER TO BE CONFIDENTIAL.</p> <p>UNDER PENALTY OF LAW FOR FALSE SWEARING (WEST VIRGINIA CODE 61-5-3), BIDDER HEREBY CERTIFIES THAT THIS</p>						

SEE REVERSE SIDE FOR TERMS AND CONDITIONS

SIGNATURE	TELEPHONE	DATE
TITLE	FEIN	ADDRESS CHANGES TO BE NOTED ABOVE

WHEN RESPONDING TO RFQ, INSERT NAME AND ADDRESS IN SPACE ABOVE LABELED 'VENDOR'





State of West Virginia  
 Department of Administration  
 Purchasing Division  
 2019 Washington Street East  
 Post Office Box 50130  
 Charleston, WV 25305-0130

# Request for Quotation

RFQ NUMBER  
**708EC004**

PAGE  
**7**

ADDRESS CORRESPONDENCE TO ATTENTION OF:  
**JOHN JOHNSTON**  
**304-558-2402**

SURVEY

RFQ COPY  
 TYPE NAME/ADDRESS HERE

SHIP TO

DIVISION OF HIGHWAYS  
 EQUIPMENT DIVISION  
 ROUTE 33  
 BRUSHY FORK ROAD  
 BUCKHANNON, WV  
 26201 304-472-1750

DATE PRINTED	TERMS OF SALE	SHIP VIA	FOB	FREIGHT TERMS
09/24/2007				

BID OPENING DATE: **11/13/2007** BID OPENING TIME **01:30PM**

LINE	QUANTITY	UOP	CAT. NO.	ITEMNUMBER	UNIT PRICE	AMOUNT
<p>CERTIFICATE IS TRUE AND ACCURATE IN ALL RESPECTS; AND THAT IF A CONTRACT IS ISSUED TO BIDDER AND IF ANYTHING CONTAINED WITHIN THIS CERTIFICATE CHANGES DURING THE TERM OF THE CONTRACT, BIDDER WILL NOTIFY THE PURCHASING DIVISION IN WRITING IMMEDIATELY.</p> <p>BIDDER: <u>LH Jones Equipment Co.</u></p> <p>DATE: <u>11/14/07</u></p> <p>SIGNED: <u>[Signature]</u></p> <p>TITLE: <u>VP</u></p> <p>* CHECK ANY COMBINATION OF PREFERENCE CONSIDERATION(S) IN EITHER "A" OR "B", OR BOTH "A" AND "B" WHICH YOU ARE ENTITLED TO RECEIVE. YOU MAY REQUEST UP TO THE MAXIMUM 5% PREFERENCE FOR BOTH "A" AND "B". (REV. 12/00)</p> <p>NOTICE</p> <p>A SIGNED BID MUST BE SUBMITTED TO:</p> <p>DEPARTMENT OF ADMINISTRATION          PURCHASING DIVISION          BUILDING 15          2019 WASHINGTON STREET, EAST          CHARLESTON, WV 25305-0130</p> <p>THE BID SHOULD CONTAIN THIS INFORMATION ON THE FACE OF</p>						

SEE REVERSE SIDE FOR TERMS AND CONDITIONS

SIGNATURE	TELEPHONE	DATE
TITLE	FEIN	ADDRESS CHANGES TO BE NOTED ABOVE

WHEN RESPONDING TO RFQ, INSERT NAME AND ADDRESS IN SPACE ABOVE LABELED 'VENDOR'



State of West Virginia  
 Department of Administration  
 Purchasing Division  
 2019 Washington Street East  
 Post Office Box 50130  
 Charleston, WV 25305-0130

# Request for Quotation

RFQ NUMBER  
**708EC004**

PAGE  
**8**

ADDRESS CORRESPONDENCE TO ATTENTION OF  
**JOHN JOHNSTON  
 304-558-2402**

RFQ COPY  
 TYPE NAME/ADDRESS HERE

VENDOR

SHIP TO

**DIVISION OF HIGHWAYS  
 EQUIPMENT DIVISION  
 ROUTE 33  
 BRUSHY FORK ROAD  
 BUCKHANNON, WV  
 26201 304-472-1750**

DATE PRINTED	TERMS OF SALE	SHIP VIA	F.O.B.	FREIGHT TERMS
09/24/2007				

BID OPENING DATE: **11/13/2007** BID OPENING TIME **01:30PM**

LINE	QUANTITY	UOP	CAT. NO.	ITEM NUMBER	UNIT PRICE	AMOUNT
<p>THE ENVELOPE OR THE BID MAY NOT BE CONSIDERED:            SEALED BID</p> <p>BUYER: 33            RFQ. NO.: 708EC004            BID OPENING DATE: 11/13/2007            BID OPENING TIME: 1:30 PM</p> <p>PLEASE PROVIDE A FAX NUMBER IN CASE IT IS NECESSARY            TO CONTACT YOU REGARDING YOUR BID:  <i>304 292 6641</i></p> <p>CONTACT PERSON (PLEASE PRINT CLEARLY):  <i>Leonard Hancock Jr</i></p>						
<p>***** THIS IS THE END OF RFQ 708EC004 ***** TOTAL:</p>						<p><i>See Pg. 22</i></p>

SEE REVERSE SIDE FOR TERMS AND CONDITIONS

SIGNATURE	TELEPHONE	DATE
TITLE	FEIN	ADDRESS CHANGES TO BE NOTED ABOVE

WHEN RESPONDING TO RFQ, INSERT NAME AND ADDRESS IN SPACE ABOVE LABELED 'VENDOR'

WEST VIRGINIA DEPARTMENT OF TRANSPORTATION  
DIVISION OF HIGHWAYS  
EQUIPMENT DIVISION

PROCUREMENT SPECIFICATIONS  
NO. 012-1-Z

OPEN END CONTRACT  
FIVE CUBIC YARD STAINLESS STEEL DEMOUNTABLE ABRASIVE  
AND CHEMICAL SPREADER (HYDRAULIC)

1.0 PURPOSE

It is the purpose of these specifications to describe a Five Cubic Yard Stainless Steel Demountable Abrasive and Chemical Spreader (Hydraulic) (hereinafter referred to as a "spreader" or a "unit") to be purchased for use by the West Virginia Division of Highways (DOH) on an Open End Contract basis.

2.0 BIDDING PROCEDURES

**The current purchasing procedures regarding bidding as established by the Department of Administration, Purchasing Division, shall apply.** Failure to submit the "Request for Quotation" forms, complete in its entirety and according to directions indicated, may subject the bidder to disqualification. **Each bid submitted shall also be accompanied by a Bidder's Evaluation Report completed in detail.** Addendums in order, along with exception sheets, should be with Bidder's Evaluation Report. **FAILURE TO SUBMIT THE BIDDER'S EVALUATION REPORT, COMPLETE IN ITS ENTIRETY, MAY RESULT IN AUTOMATIC DISQUALIFICATION.**

3.0 SPECIFICATIONS

The specifications named herein, mandatory and non-mandatory, establish the acceptable level of quality only and are not intended to reflect a preference or favor any particular brand or vendor.

3.1 EXCEPTIONS TO NON-MANDATORY SPECIFICATIONS

Exception to a non-mandatory unit specification may be made by the bidder, providing the exception is not available from the manufacturer. **Any such exception must be noted on the bidder's evaluation report and should be accompanied by supporting documentation/literature from the manufacturer. Any exception must be indicated on a separate attachment to the bidder's evaluation report and labeled as "Exception to Specifications".** The state reserves the right to determine whether the stated exception does or does not reduce the quality and performance of the unit. Failure to provide information for any exceptions may be grounds for rejection of the bid. The

state reserves the right to waive minor irregularities in bids or specifications in accordance with §148-1-4(f) of the WV Legislative Rules and Regulations.

### 3.2 MANDATORY SPECIFICATIONS

**All specifications preceded by "shall and/or must" or are stated as a "minimum and/or maximum" are mandatory. Any bid failing to meet any mandatory item shall be immediately disqualified.** Failure to respond in the appropriate evaluation section may also be grounds for immediate disqualification at the discretion of the State.

A mandatory pre-bid conference is scheduled for this equipment purchase as stated in the RFQ. Vendors having products with variations or exceptions in specified mandatory items are expected to address any such variations or exceptions during the pre-bid conference. **The State shall review and consider any such variation or exception, and may at its sole discretion, issue an addendum to change mandatory specifications deemed to be in the State's best interest. Bids from any vendor failing to attend the mandatory pre-bid shall be disqualified. Bids containing any variation or exception to a mandatory specification that was not addressed during the pre-bid conference and accepted by the issuance of an Addendum shall be disqualified.**

### 4.0 REPRESENTATIVE UNIT FOR IEST

**The successful vendor must (if specified) provide DOH one (1) completed representative unit to be observed and evaluated on each order to insure compliance with specification. If requested, the time period for testing and evaluation shall be seven (7) working days following receipt of the unit. DOH will incur no obligation for deterioration of surfaces, finishes, seals, and mechanical or electrical parts on the unit resulting from operation and testing within the limits of these specifications; nor will DOH incur obligation for damage to the unit resulting from failure to meet specifications when due care and attention is given by DOH and testing is done within the limits of these specifications. Failure of the pilot unit to satisfactorily meet specifications as bid shall be cause for cancellation of the purchase order, and return of the delivered unit along with all associated equipment to the vendor at the vendor's expense.**

### 4.1 CONDITION OF UNIT(S) UPON DELIVERY

**All units must arrive at the prescribed delivery point having been completely preserviced with oil, lubricants, and coolant. All prescribed precautions pertaining to first operations and break-in of the unit are to be posted conspicuously on the unit for ready observance by the operator.**

#### 4.2 DELIVERY

Delivery point of the completely assembled representative unit will be the DOH, Equipment Division, Route 33 at Brushy Fork Road, Buckhannon, West Virginia (26201).

The vendor is responsible for guaranteeing delivery of the completed units within the time specified and agreed to by the State. Delivery is preferred within 135 days maximum after receipt of purchase agreement. The vendor is responsible for establishing and coordinating delivery terms with allied manufacturers or suppliers. **Delivery terms shall be stated in the bid and the State reserves the right to accept or negotiate such terms.** Failure to reach an agreement may result in rejection of the bid. **The successful bidder shall provide their manufacturer's confirmation of the order to the WVDOH contact person within seven (7) working days after receiving the approved purchase order.**

**A completed pilot model for inspection must be provided within 45 calendar days after receipt of the purchase agreement by the successful vendor.**

Delivery is an integral part of this specification and failure to comply will be cause to initiate a D.O.T. Administrative Form WV-82, Vendor Performance Form. The WV-82 Form will provide a means of officially notifying the Purchasing Division and the vendor of unsatisfactory performance; such as late deliveries, poor service, inadequate parts supplies, etc.

The decision to initiate subject Form will be at the sole discretion of the D.O.H. Commissioner's established Equipment Review Board.

Issuance of the WV-82 Vendor Complaint Form on unsatisfactory delivery against any vendor will be cause to refuse to consider similar items from those vendors on future Request For Quotations.

(NOTE: Delivery time could be altered due to labor strikes, severe inclement weather conditions, etc.)

#### 5.0 AWARD CRITERIA

- 5.1 DOH will recommend the award in accordance with the RFQ evaluation criteria described in the requisition. **The award shall be made to the lowest unit cost vendor that meets or exceeds the specifications.**

**Prices for the units shall be in quantities of 1-10, 11-20, 21-30, 31-40, 41-50, and 51 and over.** However, for evaluation purposes, we will use quantities 1 -10. DOH reserves the right to place multiple orders in any quantity.

6.0 SPECIFICATIONS AND GUIDELINES - GENERAL

6.1 IDENTIFICATION OF THE UNIT BEING PROPOSED

**The bidder must identify the unit by manufacturer, model, series, and year of manufacture, in the bid to enable identification by DOH in the manufacturer's specifications of the proposed unit.** The bidder will submit complete descriptive literature of the proposed unit, to establish that the bid is the manufacturer's most current model, including latest engineering improvements, which have been, or will imminently be, regularly advertised and sold on the open market. The unit specified herein and offered to be manufactured after January 1, 2007 and be clearly identified and marked with date of manufacture.

6.2 OPERATING AND SERVICE MANUALS AND PARTS LISTS

**An operator's manual must be included with each unit upon delivery. A "line sheet" (if applicable) and Equipment Preventative Maintenance Questionnaire (as shown in X6.2 of the Bidder's Evaluation Report) must be with pilot unit upon delivery. In addition, there must be 12 service, shop, or maintenance manuals; ten (10) to be distributed to the Districts and two (2) for the Equipment Division. Also, there must be 14 parts manuals; ten (10) to be distributed to the Districts and four (4) for Equipment Division use. CD ROM is preferred in lieu of parts manuals**

**\* NOTE: MANUALS SHALL BE DELIVERED UPON COMPLETION OF DELIVERY OF TOTAL UNITS. FAILURE TO DO SO WILL DELAY PAYMENT.**

6.3 TRAINING:

Manufacturers and/or dealers will be required to stage a thorough seminar on the subjects of Preventative Maintenance, Operator and Mechanic Training. **In order to keep the operators and mechanics updated, the successful vendor shall conduct training with each purchase order against this open end contract.** Training is preferred within 2 working days after delivery of the pilot unit on the individual purchase order.

**Manufacturers and/or dealers shall be required to furnish the Training Academy with one (1) Operator's Manual to be shipped direct to Letha Lamb, WVDOH Training Academy, Post Office Box 610, Buckhannon, West Virginia 26201 prior to delivery of the pilot.**

The seminar to be held at the W. Va. Division of Highways, Equipment Division, Buckhannon, West Virginia.

#### 6.4 PREVENTIVE MAINTENANCE AND OPERATOR PROCEDURES:

**Manufacturers and/or dealers will be required to submit to the Equipment Division, in addition to the operating and service manuals, booklets and pamphlets explaining the Preventive Maintenance and Operator Procedures to be used by the operators of this equipment, and must include such things as daily prestart inspection procedure, service schedule, and routine maintenance required, safety precautions, etc.**

**The successful vendor shall furnish all training aids; i.e., videos, projectors, etc. required in conducting the training.**

#### 6.5 WARRANTY AND SERVICE POLICY

The Manufacturers warranty or service policy is to apply to the unit. Such warranty or service policy is to be recognized at any authorized unit dealer, representing manufacturer of proposed unit throughout the State of West Virginia. The applicable warranty or service policy will not be contingent upon obtaining routine service, lubrication, and servicing of the unit from factory authorized agencies. It will be the responsibility of the bidder to have available labor to repair or replace any defective replacement parts, components and materials, and to have available those replacement parts, components, and/or materials found to be defective during the terms of the warranty period. The bidder should state the labor rates, locations where parts will be stocked, availability of parts, and discounts offered for parts, when terms of the warranty offer a pro-rated cost for parts and labor. In addition, the successful bidder should offer field work to repair or replace defective parts, components, and materials found to be defective during the terms of the warranty and should provide mechanic's travel rates, mileage charges, field mechanic rates, and any surcharge for miscellaneous items, if applicable, for field work during the warranty period. Submit to Division of Highways any technical or engineering improvements during the term of the warranty. **The unit must be accompanied upon delivery by the unit's manufacturer's executed warranty or service policy.**

**A mandatory minimum two (2) year bumper to bumper basic parts and labor warranty is required for this unit.**

**THE "WARRANTY AND SERVICE POLICY QUESTIONNAIRE" ATTACHED IN THE BIDDER'S EVALUATION REPORT MUST BE COMPLETED IN ITS ENTIRETY BY THE SUCCESSFUL BIDDER OR MANUFACTURER PRIOR TO DELIVERY OF THE PILOT MODEL. (SEE SECTION X6.5 OF BIDDER'S EVALUATION REPORT).**

## 6.6 EVALUATION COMMITTEE REQUIREMENTS

Detailed component specifications, product literature, component models, required for specification compliance determination by the Evaluation Committee should be provided with each bid. Any information supplied that is contrary to/or conflicting with the specifications and/or attached Bidders Evaluation Report may be sufficient cause for rejection of bid.

## 6.7 UNSPECIFIED ACCESSORIES & FEATURES

**All parts, equipment, accessories, material, design and performance characteristics not specified herein, but which are necessary to provide a complete unit, must be furnished with each unit and required to conform to strength, quality of material, and quality of workmanship to those which are advertised and provided to the market in general by the unit industry.**

**All parts and accessories advertised and regularly supplied as standard shall be included, except those which would represent duplication of these specified, and except those which, by specification, are not to be furnished. All standard safety features, required by Federal and State Law, shall be included.**

## 7.0 SPECIFICATIONS OF THE QUOTED UNIT ARE AS FOLLOWS:

**7.1 Spreaders offered shall be of the commercial heavy-duty, self-contained, hopper type.**

**7.2 Spreaders shall consist of a 12 gauge 304 stainless steel body, feeder conveyor, spinner disc, power drive, and all components necessary to make a complete operating unit.**

**7.3 The spreader shall be capable of uniformly spreading sand, cinders, salt, calcium chloride, or other mixtures up to a width of forty (40) feet.**

**7.4 Body:**

**7.4.1 The body shall be of 304 stainless steel construction 100% welded inside and outside of the body.**

**7.4.2 The struck capacity shall be 5 cubic yards.**

**7.4.3 Inside length shall be 9 feet as measured from front of spreader hopper to the rear hopper gate and conveyor chain exit point**



- 7.4.4 Overall height to be 48 inches approximate
- 7.4.5 **Inside width to be 84 inches maximum.**
- 7.4.6 **The body sides must slope at approximately 45° pitch to insure free flow of materials to the conveyor.**
- 7.4.7 **The body sides and end-gates to be constructed with minimum 12 gauge 304 stainless steel.**
- 7.4.8 Top of the body is to have a formed double crimped section for additional support.
- 7.4.9 **Sills shall be of a minimum of 10 gauge 304 stainless steel with longitudinal flanges supported on rectangular formed cross sills.**
- 7.4.10 Approximately four (4) each side of 12 gauge 304 stainless steel full slope body side supports rigidly tying in the formed cross sills with the body sides to give the highest degree of resistance to warping or twisting under heavy loads.
- 7.4.11 **The body shall be provided with four (4) 304 stainless steel 5/8 inch round lifting eyes; the inside eye opening shall be designed to allow the passage of an alloy eye grade 80 3/8 inch grab hook with a width dimension of 2 11/16 inch (with the top screen down in the rest position on top of the spreader); two (2) on each side of spreader mounted and secured in such a manner that the entire unit may be safely lifted for storage/installation purposes.**
- 7.4.12 **All necessary hardware shall be stainless steel.**
- 7.4.13 **A 12 gauge 304 stainless steel front mounted spill shield shall be provided. The spill shield to be 76 inches wide x 20 inches long and sloped front to rear, in order that loaded material, salt, cinders, etc. will fall into hopper as spreader unloads.**
- 7.4.13.1 **A 300 series stainless steel grab handle must be mounted to the drivers side spill shield side plate at a convenient location to assist operator when climbing atop spreader to remove "chunks or debris".**
- 7.4.14 **A fold up stainless steel ladder shall be mounted on rear of spreader body at right for easier access to top. Ladder to be equipped with hand holds, non-slip strut steps, and manufacturers locking mechanism to lock ladder in up position when not in use.**
- 7.4.14.1 **A 300 series stainless steel grip strut step plate shall be mounted on rear of spreader "spinner" housing frame, above rear baffle, full width of spinner housing.**

- 7.4.15 A work light to be mounted on cab shield for night shift visibility of spreader grating with weatherproof wiring.
- 7.5 Conveyor:
- 7.5.1 **The conveyor shall be located in bottom of hopper capable of engaging material along its full length and moving the material to the rear adjustable metering gate.**
- 7.5.2 Conveyor to be continuous ladder type consisting of two parallel chains with cross bars on 4 1/2" centers made of 1/4" x 1-1/2" steel.
- 7.5.3 **Each cross bar shall be formed and welded both top and bottom to chain links**
- 7.5.4 **Tensile strength of each chain shall be 20,000 pounds minimum**
- 7.5.5 **Overall width of chain conveyor 20 inches minimum**
- 7.5.6 **Replaceable rubber wear strips to prevent contact of material being spread with the chain must be provided.**
- 7.5.7 **A 10 gauge 304 stainless steel heavy-duty replaceable conveyor plate shall be fitted.**
- 7.5.8 **The chain drive shall be through 1-1/2" sprockets and shafting front and rear.**
- 7.5.9 **Conveyor shall have adjustment provisions at rear of spreader for at least 3" lateral takeup.**
- 7.5.10 Additional 7 gauge 304 stainless steel reinforcing plate to be welded to longitudinal webs covering area of drive shaft bearing and idler bearing adjustment.
- 7.5.11 **The material composition of the adjustment mechanism shall be rust proof or rust resistant.**
- 7.5.12 **The conveyor drive motor shall be mounted on hopper side of the reduction gear box and have a ratio of approximately 50-1.**
- 7.5.13 **Conveyor gear box must have its drive shaft extended through the rear of gear housing, and the shaft end machined to accommodate the application rate sensor shaft for the Dickey-John Automatic Control System, Model ICS-2000. The necessary oil seal included.**
- 7.5.13.1 **Adequate shielding shall be provided that will cover exposed shaft, coupling, and application rate sensor.**

7.5.14 A 7 gauge stainless steel adjustable discharge gate of the greasable screw jack type to be located at the body rear to properly adjust the flow of material to the spinner.

7.5.15 Feedgate opening 12" high x 18" wide.

**7.5.16 Any and all exposed moving or rotating mass shall be adequately shielded in order to protect personnel while performing required operational adjustments.**

7.6 Distributor Spinner Assembly:

**7.6.1 The distributor disc shall be of urethane material approximately 20" in diameter and equipped with six (6) fins (approximately) designed to obtain a controlled spread of four feet (4') to forty feet (40').**

**7.6.2 Material shall be guided from conveyor end to distributor disc by means of an externally adjustable material flow baffles, enclosed within the chute.**

**7.6.3 Spinner shall be vertically adjustable approximately 16" and provide approximately a 20" to 32" spinner position below the mounting surface.**

**7.6.4 A deflector baffle or diverter chute shall be provided in the enclosed distributor spinner hopper assembly so it can be positioned in such a manner that material can be unloaded from spreader without striking spinner.**

7.7 Baffles:

**7.7.1 Baffles shall be provided to control direction and width of spread. To have four (4) sections over right, left, rear, and front of spinners.**

**7.7.2 Baffle sections must be easily adjusted in desired position, from full down to horizontal, without use of tools .**

7.8 Power Drive:

**7.8.1 The power drive shall be hydraulic having two (2) hydraulic motors -one (1) powering the spinner and one (1) the conveyor.**

7.8.2 The spinner hydraulic motor to be mounted below the spinner hopper assembly.

7.8.3 The conveyor hydraulic motor to be of the orbital, low speed, hi-torque type integrally mounted to conveyor gear box.

7.9 Pintle Conveyor Chain:

**7.9.1 The pintle conveyor chain shall be heat treated formed links with locked, non-turning pins.**

7.9.2 Tensile strength of each chain strand to be approximately 21,000 pounds.

7.10 Screen Over Hopper:

**7.10.1 A minimum of four (4) sectional screens to be hinged to 10 gauge 304 stainless steel 4 inch x 6 inch formed box beam running longitudinally the full length of spreader hopper.**

7.10.2 Screen sections to have 3/8" diameter rods welded to 3/16" - 2" angle frame forming 2-1/2" x 2-1/2" square openings.

7.10.3 Screens should not increase the overall height of spreader more than 7" down center.

7.11 Lighting to be in accordance with the attached sketch.

7.11.1 Combination and marker lights to be LED type

**7.11.2 Stop, tail, turn combination lights and marker lights shall be shielded.**

**7.11.3 Strobe light shall be "quad flash"**

**7.12 Hydraulic Components: The following hydraulics shall be supplied with each spreader (hose lengths to be determined by spreader vendor) to provide for proper installation on DOH dump trucks.**

**7.12.1 All necessary fittings for complete hookup of spreader hydraulics to DOH dump trucks central hydraulic system shall be provided.**

**7.12.2 All fittings shall be the steel type designed for hydraulic use: galvanized iron pipe or fittings not acceptable.**

**7.12.3 The truck central hydraulic system, supplied and installed by another vendor, will be complete to and including the rear manifold, located at the rear cross-member of truck. The rear manifold will have attached to it one (1) 3/4" I.D. pressure line with 3/4" quick disconnect, one (1) 1/2" I.D. pressure line with 1/2" quick disconnect, one (1) 1" I.D. return line with 1-1/4" quick disconnect. The quick disconnects will be "VH" series snap-tite. The spreader vendor shall supply proper mating quick disconnects, metal caps, and plugs for connection to truck manifold.**

**7.13 An anodized 6061T6 aluminum grease manifold block shall be mounted at the rear of the body incorporating the front bearing grease extension tubes, rear bearing grease fittings, and feedgate screw jack lubrication tube to allow for lubrication of the front bearings and feedgate screw jack from a single convenient location. Other fittings shall be placed at convenient location for normal maintenance.**

- 7.13.1** The anodized 6061T6 aluminum grease manifold block shall have a minimum of six (6) ports tapped to accept three (3) 1/8 inch straight grease zerks and three (3) 1/8 inch grease Parflex hoses to provide for adequate one location greasing of the front and rear bearings and feed gate screw jack. Any unused ports are to be properly plugged.
- 7.13.2** All hoses incorporated into the grease manifold block system shall be Parflex hose manufactured by Parker Hannifan Corporation or equal, and shall have an inside diameter of 1/8 inch, a maximum outside diameter of 0.34 inch, a maximum working pressure of 2500 psi and a minimum burst pressure of 10,000 psi. The hoses used shall be held in place by a sufficient number of rubber cushioned hose clamps.
- 7.14** One (1) piece of angle iron 3/8" x 4" x 90" and two (2) pieces of 1" round shafting ten inches (10") long shall be included to construct a safety keeper bar. State forces will add this item when the hopper is mounted, vendor shall supply material.
- 7.15** Unit shall include all other features considered as standard equipment but not specifically addressed above.
- 7.16** Paint: All parts and accessories that are not required to be stainless or rustproof to be painted manufacturers standard color.
- 7.17** Vendor must certify that spreader offered will comply with "Occupational Safety and Health Act of 1970" and subsequent amendments.
- 7.18** Advertisement: Vendors are permitted to attach a permanent metal plate 4" x 6" maximum size to the unit for identification. All other types of advertising, decals, labels, etc. will interfere with West Virginia Division of Highway's standards and are not permitted.

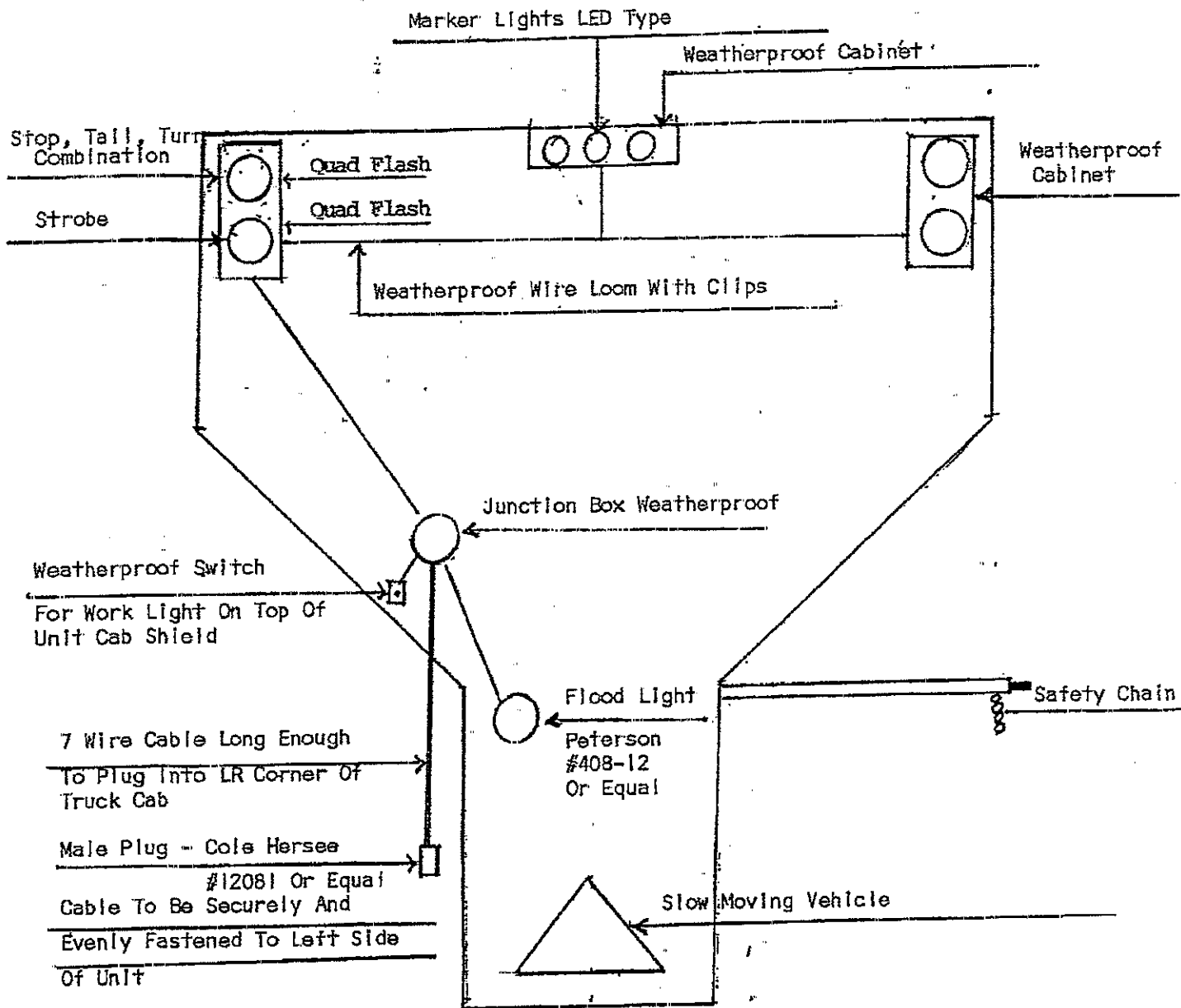

WEST VIRGINIA DEPARTMENT OF TRANSPORTATION  
DIVISION OF HIGHWAYS  
EQUIPMENT DIVISION

21

NOTE: Vendor should type  
Bidder's Evaluation  
Report.

BIDDER'S EVALUATION REPORT

PROCUREMENT SPECIFICATIONS FOR OPEN END CONTRACT  
NO. 012-1-Z

OPEN END CONTRACT  
FIVE CUBIC YARD STAINLESS STEEL DEMOUNTABLE ABRASIVE  
AND CHEMICAL SPREADER (HYDRAULIC)

NOTE TO BIDDER: Procurement Specification No. 012-1-Z, Paragraph 2.0 recommends the completion and submittal of this Report with your bid. Purpose of this Report is to enable the West Virginia Division of Highways Evaluation Committee to make full and fair evaluation of the bid. Addendums in order, along with exception sheets, should be with Bidder's Evaluation Report.  
FAILURE TO SUBMIT THIS REPORT, COMPLETE IN ITS ENTIRETY, MAY SUBJECT THE BIDDER TO DISQUALIFICATION.

Reference Requisition No.: 708 ECC04

Bidder's Name: LH Jones Equipment Co.

Address: 1825 EARL COLE RD. MORGANTOWN, WV 26505

Telephone Number: 304 792 1207

Years Bidder has been registered to do business with the State of West Virginia: 30 YRS.

Years Company has been an authorized dealer for proposed unit: 21 YRS.

X3.2 Have you complied with all mandatory specifications?  YES  NO

X4.2 DELIVERY:

X4.2.1 Delivery date of completed representative unit: 45 Calendar Days After Date of Purchase Agreement

X4.2.2 Delivery date of balance of completed units: 135 Calendar Days After Date of Purchase Agreement

## X5.0 AWARD CRITERIA;

## X5.1 Prices for units in quantities of

1-10	<u>14 634.00</u>	per unit
11-20	<u>15 634.00</u>	per unit
21-30	<u>15 634.00</u>	per unit
31-40	<u>15 634.00</u>	per unit
41-50	<u>15 634.00</u>	per unit
51 and over	<u>16 634.00</u>	per unit

## X6.0 SPECIFICATIONS - GENERAL

## X6.1 Manufacturer, model, series, and date of manufacture of proposed unit:

Buyers Products, Model: 1450548SSH, Series: MUNICIPAL, Date of mfg: 2007-08  
 Is descriptive literature, fully describing proposed unit attached to your bid?  YES  NO

If not, why? Literature depicts standard unit. Bid unit modified to fully comply with the specifications.

## X6.2 Will the required number of service manuals, and complete parts list be delivered to the Equipment Division at Buckhannon upon completion of delivery of total units?

YES  NO

Will the required Equipment Preventive Maintenance Form (Section X6.2 of Bidders Evaluation Report) be provided upon inspection of the pilot unit?

YES  NO



EQUIPMENT PREVENTATIVE MAINTENANCE QUESTIONNAIRE

THIS FORM MUST BE COMPLETED IN ITS ENTIRETY BY SUCCESSFUL BIDDER OR MANUFACTURER=S TECHNICAL REPRESENTATIVE PRIOR TO DELIVERY OF PILOT MODEL TO THE WVD0H.

DESCRIPTION: \_\_\_\_\_ MAKE: \_\_\_\_\_

MODEL: \_\_\_\_\_ YEAR: \_\_\_\_\_ PURCHASE AMOUNT: \_\_\_\_\_

ENGINE: MAKE: \_\_\_\_\_ MODEL: \_\_\_\_\_ FUEL TYPE: \_\_\_\_\_

HORSEPOWER: \_\_\_\_\_ CYLINDER: \_\_\_\_\_ ENGINE SERIAL: \_\_\_\_\_

COOLING SYSTEM CAPACITY: \_\_\_\_\_

BELTS: DESCRIPTION: \_\_\_\_\_ PART NUMBERS: \_\_\_\_\_

\_\_\_\_\_  
\_\_\_\_\_

GVW: \_\_\_\_\_ AXLE CAPACITY: FRONT: \_\_\_\_\_ REAR: \_\_\_\_\_

TIRES: FRONT MAKE & SIZE: \_\_\_\_\_

REAR MAKE & SIZE: \_\_\_\_\_

DIMENSIONS OF UNIT: LENGTH: \_\_\_\_\_ WIDTH: \_\_\_\_\_ LENGTH: \_\_\_\_\_

VENDOR CONTACT PERSON: \_\_\_\_\_ PHONE: \_\_\_\_\_

PARTS:

BATTERY MAKE: \_\_\_\_\_ MODEL: \_\_\_\_\_ CCA: \_\_\_\_\_

TOP OR SIDE POST: \_\_\_\_\_ DIMENSIONS: LENGTH \_\_\_\_\_ WIDTH \_\_\_\_\_ HEIGHT \_\_\_\_\_

SPARK PLUGS OR FUEL INJECTORS MAKE: \_\_\_\_\_ PART # \_\_\_\_\_

FUEL PUMP OR INJECTION PUMP MAKE: \_\_\_\_\_ MODEL: \_\_\_\_\_

ALTERNATOR MAKE: \_\_\_\_\_ PART #: \_\_\_\_\_

STARTER MAKE: \_\_\_\_\_ PART #: \_\_\_\_\_

TURBO CHARGER MAKE: \_\_\_\_\_ PART #: \_\_\_\_\_

TRANS. MAKE: \_\_\_\_\_ MODEL: \_\_\_\_\_ AUTO/MANUAL: \_\_\_\_\_

HYDRAULIC PUMP MAKE: \_\_\_\_\_ MODEL: \_\_\_\_\_

FILTERS	MAKE	PART NO.	LUBRICANT	MANUFACTURER TYPE
OIL	_____	_____	ENGINE	_____
AIR INNER	_____	_____	TRANSMISSION	_____
AIR OUTER	_____	_____	POWER STEERING	_____
FUEL PRIMARY	_____	_____	HYDRAULIC	_____
FUEL SECONDARY	_____	_____	DIFFERENTIALS	_____
COOLANT	_____	_____	BRAKE FLUID	_____
HYDRAULIC	_____	_____	COOLANT	_____
OTHER	_____	_____	OTHER	_____

To be completed upon award

X6.3 TRAINING:

Will training seminar be conducted on Preventive Maintenance, Operator and Mechanic Training  YES  NO

Will you conduct training with each purchase order against this open end contract?  YES  NO

Will training be conducted within 2 working days from the delivery of the pilot unit on the individual purchase order?  YES  NO

If NO, explain time frame \_\_\_\_\_

Will an Operator's Manual be furnished directly to Letha Lamb, Training Academy prior to the delivery of the pilot?  YES  NO

X6.4 If you are the successful vendor, will you furnish all training aids, i.e., videos, projectors, required in conducting the training?  YES  NO

X6.4.1 Will all manuals, booklets, etc. explaining preventive maintenance, operator procedures, and service schedule be delivered with each unit?  YES  NO  
If NO, explain \_\_\_\_\_

X6.5 WARRANTY AND SERVICE POLICY

Will the warranty and service you provide comply with all areas as stated in Section 6.5 of specifications  YES  NO

Is warranty literature attached?  YES  NO

Is a minimum two (2) year bumper to bumper basic parts and labor warranty included?  YES  NO

Describe: Standard warranty statement attached. Bid warranty  
statement is 2 years, not one year as indicated in the  
standard statement. See also page 25.  
Labor included as per specification.

X6.5 WARRANTY AND SERVICE POLICY QUESTIONNAIRE

THIS FORM MUST BE COMPLETED IN ITS ENTIRETY BY THE SUCCESSFUL BIDDER OR MANUFACTURERS TECHNICAL REPRESENTATIVE PRIOR TO DELIVERY OF PILOT MODEL TO THE WVDOH (If additional lines are needed, make copies of form )

1. Define the terms of the standard warranty. If not offered, so state. (Attach copy)

See the attached copy. However, the bid warranty is  
two (2) years, not one (1) year. Labor included as per  
specification.

2. Define warranty service to be performed at DOH facilities and warranty service to be performed at manufacturer's representative facility. List name and location of manufacturer's representative.

Major / Structural repairs to be conducted at LH Jones Equipment Co.  
Minor repairs to be conducted at DOH facilities.  
Mfg. Rep: LH Jones Equipment Co., 1825 EARL COLE RD, MORGANTOWN, WV, 26505

3. List locations for parts inventories that are within the State of West Virginia. Also, list availability levels, if known.

<u>LH Jones Equipment Co.</u>	<u>Availability levels</u>
<u>1825 EARL COLE RD.</u>	<u>Currently unknown.</u>
<u>MORGANTOWN, WV 26505</u>	

4. During the term of warranty, list the guarantee discount to manufacturer's published list price for parts that bidder will sell the parts to owner.

- |                  |   |          |            |
|------------------|---|----------|------------|
| A. Terms: Net 30 | Manufacturer's published list price less: | <u>0</u> | % discount |
| B. Terms: Net 60 | Manufacturer's published list price less: | <u>0</u> | % discount |
| C. Terms: Net 90 | Manufacturer's published list price less: | <u>0</u> | % discount |

5. During the term of warranty, will all manufacturers or engineering improvements be submitted to Division of Highways? ✓ YES      NO

6. During the term of warranty, list the guaranteed rates charged for repair to the unit.

- A. Shop Rate \$ 60 per mechanic hour
- B. Travel Time Charge \$ 60 per mechanic hour  
(Specify if one-way) \_\_\_\_\_; port to port ✓
- C. Mileage Charge \$ 1.25 per vehicle mile  
(Specify if one-way) \_\_\_\_\_; port to port ✓
- D. Field Mechanic Rate \$ 60 per mechanic hour
- E. Specify period of time that prices are in effect: two years
- F. Surcharge for miscellaneous items: net charge for air freight / expedited freight

## X6.6 EVALUATION COMMITTEE REQUIREMENTS

Is all component specifications, product literature, component models provided for Evaluation Committee bid determination?  YES  NO

X6.7 Will all parts, equipment, accessories, material, design and performance characteristics not specified herein, but which are necessary to provide a complete unit, be furnished with the unit and conform in strength, quality of material, and quality of workmanship to those which are advertised and provided to the market in general by the unit industry?

YES  NO

X6.7.1 Are all parts and accessories adequate and regularly supplied as standard to be included except those which may be duplications of specifications herein, and except these by specification are not to be furnished?

YES  NO

X6.7.2 Are all standard safety features that are required by Federal and State statutes of law included?

YES  NO

## X7.0 SPECIFICATIONS OF THE QUOTED UNIT

The bidder should complete the following schedule in order for the Division of Highways to compare the actual bid unit to the specifications. Should the bidder except a requirement, then such exception may be only on the basis that such feature is not offered by the manufacturer. The Division will have the sole discretion as to whether the bidder's substitution meets the requirements of the specifications.

Manufacturer: Buyers Products Model: 1450548 SSH

X7.1 Is spreaders offered the commercial heavy duty, self contained, hopper type?  YES  NO

X7.2 Does spreader consist of a 12 gauge 304 stainless steel body, feeder conveyor, spinner disc, power drive, and all components necessary to make a complete operating unit?  YES  NO

X7.3 Is the unit capable of uniformly spreading sand, cinders, salt, calcium chloride, or other mixtures up to a width of forty (40) feet?  YES  NO

X7.4 Body:

X7.4.1 Is the body of 304 stainless steel construction 100% welded inside and outside of the body?  YES  NO

X7.4.2 Capacity struck: 5 CUBIC YARDS

X7.4.3 Inside length: 9 FEET as measured from front of spreader hopper to the rear hopper gate and conveyor chain exit point

X7.4.4 Overall height: 48 INCHES

X7.4.5 Inside width: 84 INCHES

X7.4.6 Are the body sides sloped approximately 45° pitch to insure free flow of materials to the conveyor  YES  NO

X7.4.7 Gauge of 304 stainless steel in sides and endgates is 12 Gauge.

X7.4.8 Is a formed double crimped section on top of body for additional support?  YES  NO

X7.4.9 Sills constructed of 10 gauge 304 stainless steel.

Supported on rectangular formed cross sills  YES  NO

X7.4.10 Number of 12 gauge full slope body side supports tying the cross sills with body sides? 4

X7.4.11 Are four (4) 304 stainless steel 5/8 inch round lifting eyes fitted to spreader; inside eye opening designed to allow the passage of an alloy eye grade 80 3/8 inch grab hook with a width dimension of 2 11/16 inch (with top screen down in the rest position on top of spreader  YES  NO

two (2) on each side of spreader mounted and secured in such a manner that the entire unit may be safely lifted for storage/installing purposes  YES  NO

X7.4.12 Is all necessary hardware stainless steel  YES  NO

X7.4.13 Is a 12 gauge 304 stainless steel front mounted spill shield provided?  YES  NO

Is the spill shield 76 inches wide x 20 inches long and sloped front to rear, in order that loaded material, salt, cinders, etc. will fall into hopper as spreader unloads?  YES  NO

X7.4.13.1 Is a 300 series stainless steel grab handle mounted to the drivers side spill shield side plate at a convenient location to assist operator when climbing atop spreader to remove "chunks or debris"?  YES  NO

X7.4.14 Will a fold up stainless steel ladder be mounted on the rear of spreader body at right for easier access to top?  YES  NO

Does the ladder have hand holds, non-slip strut steps, and manufacturers locking mechanism to lock ladder in up position when not in use?  YES  NO

X7.4.14.1 Is a 300 series stainless steel grip strut step plate mounted on rear of spreader "spinner" housing frame, above rear baffle, full width of spinner housing?  YES  NO

X7.4.15 Is a work light mounted on cab shield for night shift visibility of spreader grating with weatherproof wiring?  YES  NO

X7.5 Conveyor:

X7.5.1 Is the conveyor located in bottom of hopper and capable of engaging material along its full length and moving material to rear adjustable metering gate?  YES  NO

- X7.5.2 Is conveyor continuous ladder type consisting of two parallel chains with cross bars on 4 2" centers made of 1/4" x 1-1/2" steel?  YES  NO
- X7.5.3 Is each cross bar formed and welded both top and bottom to chain links  YES  NO
- X7.5.4 Tensile strength of each chain: 21,000 pounds
- X7.5.5 Overall width of chain conveyor: 20 inches
- X7.5.6 Are replaceable rubber wear strips provided to prevent contact of material being spread with the chain? SEE ADDENDUM #1  YES  NO
- X7.5.7 Is a 10 gauge 304 stainless steel heavy-duty replaceable conveyor plate at least 3/16" thick fitted?  YES  NO
- X7.5.8 Is the chain drive through 1-1/2" sprockets and shafting front and rear?  YES  NO
- X7.5.9 Does conveyor have adjustment provisions at rear of spreader for at least 3" lateral takeup?  YES  NO
- X7.5.10 Is additional 7 gauge 304 stainless steel reinforcing plate welded to longitudinal webs covering the area of the drive shaft, bearing, and idler bearing provided? See addendum #1  YES  NO
- X7.5.11 Is material composition of adjustment mechanism rust proof?  YES  NO
- X7.5.12 Is conveyor drive motor mounted on hopper side of reduction gear box?  YES  NO
- X7.5.12.1 Does the reduction gear box provide a 50:1 ratio?  YES  NO
- X7.5.13 Does conveyor gear box have its drive shaft extended through rear of gear housing?  
See addendum #1  YES  NO
- Is the shaft end machined to accommodate the application rate sensor shaft for the Dickey-John Automatic Control System, Model ICS-2000?  YES  NO
- Is the necessary oil seal included?  YES  NO
- X7.5.13.1 Is adequate shielding provided that will cover exposed shaft, coupling, and application rate sensor?  YES  NO
- X7.5.14 Is a 7 gauge stainless steel adjustable greasable screw jack type discharge gate located at the body rear to adjust the flow of material to the spinner?  YES  NO
- X7.5.15 Feedgate opening: 12 inches high x 18 inches wide
- X7.5.16 Is any and all exposed moving or rotating mass adequately shielded in order to protect personnel while performing required operational adjustments?  YES  NO

## X7.6 Distributor Spinner Assembly:

X7.6.1 Diameter of urethane distributor disc 20 inchesX7.6.1.1 Number of fins: 6X7.6.1.2 Are fins designed to obtain a controlled spread of materials from four feet (4') to forty feet (40')?  YES  NOX7.6.2 Is material guided from conveyor end to distributor disc by means of an externally adjustable material flow baffles, enclosed within the chute?  YES  NOX7.6.3 Is the spinner vertically adjustable to a full 16 inches?  YES  NO  
and \_\_\_\_\_ inch spinner position below mounting surface? *See addendum #1*X7.6.4 Is a deflector baffle or diverter chute provided in an enclosed distributor spinner hopper assembly so it can be positioned in such a manner that material can be unloaded from spreader without striking spinner?  YES  NO

## X7.7 Baffles:

X7.7.1 Are baffles provided to control direction and width of spread? *See addendum #1*  YES  NOX7.7.1.2 Are there four (4) sections over right, left, rear and front of spinners? *See addendum #1*  YES  NOX7.7.2 Are sections easily adjusted from the full down to the horizontal position without use of tools?  YES  NO

## X7.8. Power Drive:

X7.8.1 Is the power drive hydraulic type?  YES  NOX7.8.1.2 Are two (2) hydraulic motors provided - one (1) powering the spinner assembly and one (1) powering the conveyor?  YES  NOX7.8.2 Spinner hydraulic motor mounted below the spinner hopper assembly?  YES  NOX7.8.3 The conveyor hydraulic motor of the orbital, low speed, hi-torque integrally mounted to conveyor gear box?  YES  NO

## X7.9 Pintle Conveyor Chain:

X7.9.1 Is the pintle conveyor chain constructed of heat treated formed links with locked, non-turning pins?  YES  NOX7.9.2 Specify tensile strength of each conveyor chain strand 21,000 pounds

## X7.10 Screen Over Hopper:

X7.10.1 Are four (4) sectional screens hinged to 10 gauge 304 stainless steel 4 inch x 6 inch formed box beam running longitudinally the full length of spreader hopper?  YES  NO

If not specify: \_\_\_\_\_

X7.10.2 Do screen sections have 3/8" diameter rods welded to 3/16" - 2:" angle frame forming 2-1/2" x 2-1/2" square openings?  YES  NO

If not specify: \_\_\_\_\_

X7.10.3 Do screens increase overall height of spreader more than 7 inches down the center?  YES  NO

X7.11 Is lighting in accordance with the attached sketch?  YES  NO

*See addendum #1*

X7.11.1 Is the combination and marker lights LED type  YES  NO

X7.11.2 Stop, tail, turn combination lights and marker lights are shielded  YES  NO

X7.11.3 Strobe light is "quad flash"  YES  NO

#### X7.12 Hydraulic Components:

X7.12.1 Are all necessary fittings for complete hookup of spreader hydraulics to DOH dump trucks central hydraulic system provided?  YES  NO

X7.12.2 Are all fittings of the steel type and designed for hydraulic use?  YES  NO

X7.12.3 Will the hoses mate with the quick disconnects on the central hydraulic system of the truck? *See addendum #1*  YES  NO

Will you furnish proper mating quick disconnects, metal caps, and plugs for connection to truck manifold?  YES  NO

X7.13 Is an anodized 6061T6 aluminum grease manifold block mounted at the rear of the body which incorporates the front bearing grease extension tubes, rear bearing grease fittings and feedgate screw jack lubrication tube? *See addendum #1*  YES  NO

X7.13.1 Are all other fittings placed at convenient locations for normal maintenance? *See addendum #1*  YES  NO

Number of grease manifold block ports: \_\_\_\_\_

X7.13.2 Are hoses used in the grease manifold system Parflex hose by Parker Hannifin or equal, with 1/8 inch I.D., 0.34 inch maximum O.D., a maximum working pressure of 2500 psi and a minimum burst pressure of 10,000 psi?  YES  NO

Are hose assemblies held in place by a sufficient number of rubber cushioned hose clamps?  YES  NO

X7.14 Is one (1) piece of angle iron 3/8" x 4" X 90" and two (2) pieces of 1" round shafting ten inches (10") long provided but not installed for each unit?  YES  NO



**X7.15 Other standard features:**

List other standard features offered but not specifically addressed above:

---

---

---

---

**X7.16 Paint:**

Describe method of painting parts and accessories that are not required to be stainless or rustproof:

*Industry standard wet paint or powder coat finishes as required by specifications*

---

---

**X7.17 Does unit offered meet or exceed "Occupational Safety and Health Act of 1970"?**

YES  NO

**X7.18 Does unit conform to the advertising guidelines?**

YES  NO

AGREEMENT ADDENDUM

In the event of conflict between this addendum and the agreement, this addendum shall control:

1. ARBITRATION - Any references to arbitration contained in the agreement are hereby deleted. Disputes arising out of the agreement shall be presented to the West Virginia Court of Claims.
2. HOLD HARMLESS - Any clause requiring the Agency to indemnify or hold harmless any party is hereby deleted in its entirety.
3. GOVERNING LAW - The agreement shall be governed by the laws of the State of West Virginia. This provision replaces any references to any other State's governing law.
4. TAXES - Provisions in the agreement requiring the Agency to pay taxes are deleted. As a State entity, the Agency is exempt from Federal, State, and local taxes and will not pay taxes for any Vendor including individuals, nor will the Agency file any tax returns or reports on behalf of Vendor or any other party.
5. PAYMENT - Any references to prepayment are deleted. Payment will be in arrears.
6. INTEREST - Should the agreement include a provision for interest on late payments, the Agency agrees to pay the maximum legal rate under West Virginia law. All other references to interest or late charges are deleted.
7. RECOURPMENT - Any language in the agreement waiving the Agency's right to set-off, counterclaim, recoupment, or other defense is hereby deleted.
8. FISCAL YEAR FUNDING - Service performed under the agreement may be continued in succeeding fiscal years for the term of the agreement, contingent upon funds being appropriated by the Legislature or otherwise being available for this service. In the event funds are not appropriated or otherwise available for this service, the agreement shall terminate without penalty on June 30. After that date, the agreement becomes of no effect and is null and void. However, the Agency agrees to use its best efforts to have the amounts contemplated under the agreement included in its budget. Non-appropriation or non-funding shall not be considered an event of default.
9. STATUTE OF LIMITATION - Any clauses limiting the time in which the Agency may bring suit against the Vendor, lessor, individual, or any other party are deleted.
10. SIMILAR SERVICES - Any provisions limiting the Agency's right to obtain similar services or equipment in the event of default or non-funding during the term of the agreement are hereby deleted.
11. ATTORNEY FEES - The Agency recognizes an obligation to pay attorney's fees or costs only when assessed by a court of competent jurisdiction. Any other provision is invalid and considered null and void.
12. ASSIGNMENT - Notwithstanding any clause to the contrary, the Agency reserves the right to assign the agreement to another State of West Virginia agency board or commission upon thirty (30) days written notice to the Vendor and Vendor shall obtain the written consent of Agency prior to assigning the agreement.
13. LIMITATION OF LIABILITY - The Agency, as a State entity, cannot agree to assume the potential liability of a Vendor. Accordingly, any provision limiting the Vendor's liability for direct damages or limiting the Vendor's liability under a warranty to a certain dollar amount or to the amount of the agreement is hereby deleted. In addition, any limitation is null and void to the extent that it precludes any action for injury to persons or for damages to personal property.
14. RIGHT TO TERMINATE - Agency shall have the right to terminate the agreement upon thirty (30) days written notice to Vendor.
15. TERMINATION CHARGES - Any provision requiring the Agency to pay a fixed amount or liquidated damages upon termination of the agreement is hereby deleted. The Agency may only agree to reimburse a Vendor for actual costs incurred or losses sustained during the current fiscal year due to wrongful termination by the Agency prior to the end of any current agreement term.
16. RENEWAL - Any reference to automatic renewal is hereby deleted. The agreement may be renewed only upon mutual written agreement of the parties.
17. INSURANCE - Any provision requiring the Agency to insure equipment or property of any kind and name the Vendor as beneficiary or as an additional insured is hereby deleted.
18. RIGHT TO NOTICE - Any provision for repossession of equipment without notice is hereby deleted. However, the Agency does recognize a right of repossession with notice.
19. ACCELERATION - Any reference to acceleration of payments in the event of default or non-funding is hereby deleted.
20. AMENDMENTS - All amendments, modifications, alterations or changes to the agreement shall be in writing and signed by both parties. No amendment, modification, alteration or change may be made to this addendum without the express written approval of the Purchasing Division and the Attorney General.

ACCEPTED BY:  
STATE OF WEST VIRGINIA

Spending Unit: \_\_\_\_\_

Signed: \_\_\_\_\_

Title: \_\_\_\_\_

Date: \_\_\_\_\_

VENDOR

Company Name: LH Jones Equipment Co.

Signed: \_\_\_\_\_

Title: \_\_\_\_\_

Date: 11/14/07

STATE OF WEST VIRGINIA  
Purchasing Division

# PURCHASING AFFIDAVIT

**West Virginia Code §5A-3-10a states:** No contract or renewal of any contract may be awarded by the state or any of its political subdivisions to any vendor or prospective vendor when the vendor or prospective vendor or a related party to the vendor or prospective vendor is a debtor and the debt owed is an amount greater than one thousand dollars in the aggregate

**DEFINITIONS:**

"Debt" means any assessment, premium, penalty, fine, tax or other amount of money owed to the state or any of its political subdivisions because of a judgment, fine, permit violation, license assessment, defaulted workers' compensation premium, penalty or other assessment presently delinquent or due and required to be paid to the state or any of its political subdivisions, including any interest or additional penalties accrued thereon.

"Debtor" means any individual, corporation, partnership, association, limited liability company or any other form or business association owing a debt to the state or any of its political subdivisions. "Political subdivision" means any county commission; municipality; county board of education; any instrumentality established by a county or municipality; any separate corporation or instrumentality established by one or more counties or municipalities, as permitted by law; or any public body charged by law with the performance of a government function or whose jurisdiction is coextensive with one or more counties or municipalities. "Related party" means a party, whether an individual, corporation, partnership, association, limited liability company or any other form or business association or other entity whatsoever, related to any vendor by blood, marriage, ownership or contract through which the party has a relationship of ownership or other interest with the vendor so that the party will actually or by effect receive or control a portion of the benefit, profit or other consideration from performance of a vendor contract with the party receiving an amount that meets or exceed five percent of the total contract amount.

**EXCEPTION:** The prohibition of this section does not apply where a vendor has contested any tax administered pursuant to chapter eleven of this code, workers' compensation premium, permit fee or environmental fee or assessment and the matter has not become final or where the vendor has entered into a payment plan or agreement and the vendor is not in default of any of the provisions of such plan or agreement.

**LICENSING:** Vendors must be licensed and in good standing in accordance with any and all state and local laws and requirements by any state or local agency of West Virginia, including, but not limited to, the West Virginia Secretary of State's Office, the West Virginia Tax Department, West Virginia Insurance Commission, or any other state agencies or political subdivision. Furthermore, the vendor must provide all necessary releases to obtain information to enable the Director or spending unit to verify that the vendor is licensed and in good standing with the above entities.

**CONFIDENTIALITY:** The vendor agrees that he or she will not disclose to anyone, directly or indirectly, any such personally identifiable information or other confidential information gained from the agency, unless the individual who is the subject of the information consents to the disclosure in writing or the disclosure is made pursuant to the agency's policies, procedures and rules. Vendors should visit [www.state.wv.us/admin/purchase/privacy](http://www.state.wv.us/admin/purchase/privacy) for the Notice of Agency Confidentiality Policies.

Under penalty of law for false swearing (West Virginia Code, §61-5-3), it is hereby certified that the vendor acknowledges the information in this said affidavit and are in compliance with the requirements as stated.

Vendor's Name: LH Jones Equipment Co.

Authorized Signature:  Date: 11/14/07



State of West Virginia  
 Department of Administration  
 Purchasing Division  
 2019 Washington Street East  
 Post Office Box 50130  
 Charleston, WV 25305-0130

# Request for Quotation

RFQ NUMBER  
**708EC004**

PAGE  
**1**

ADDRESS CORRESPONDENCE TO ATTENTION OF  
**MICHAEL AUSTIN  
 304-558-2402**

RFQ COPY  
 TYPE NAME/ADDRESS HERE

VENDOR

SHIP TO

DIVISION OF HIGHWAYS  
 EQUIPMENT DIVISION  
 ROUTE 33  
 BRUSHY FORK ROAD  
 BUCKHANNON, WV  
 26201 304-472-1750

DATE PRINTED	TERMS OF SALE	SHIP VIA	F.O.B.	FREIGHT TERMS
11/01/2007	<i>Not 30 Days</i>	<i>Motor Freight</i>	<i>Buckhannon, WV</i>	<i>No Charge</i>
BID OPENING DATE: 11/13/2007		BID OPENING TIME 01:30PM		

LINE	QUANTITY	UOP	CAT NO	ITEM NUMBER	UNIT PRICE	AMOUNT
ADDENDUM NO. 1						
CHANGES TO THE SPECIFICATIONS PER THE ATTACHED.						
BID OPENING DATE AND TIME REMAINS 11/13/07 @ 1:30 P.M.						
NO OTHER CHANGES.						
0001	1	EA		765-66		
FIVE CUBIC YARD STAINLESS STEEL (HYDRAULIC) SPREADER						<i>See pg. 22 of Bid.</i>
***** THIS IS THE END OF RFQ 708EC004 ***** TOTAL:						<i>See pg. 22 of Bid</i>

SEE REVERSE SIDE FOR TERMS AND CONDITIONS

SIGNATURE *[Signature]* TELEPHONE *304 292 1302* DATE *11/14/07*  
 TITLE *[Signature]* FEIN *55-0551865* ADDRESS CHANGES TO BE NOTED ABOVE

WHEN RESPONDING TO RFQ, INSERT NAME AND ADDRESS IN SPACE ABOVE LABELED 'VENDOR'

**GENERAL TERMS & CONDITIONS  
REQUEST FOR QUOTATION (RFQ) AND REQUEST FOR PROPOSAL (RFP)**

1. Awards will be made in the best interest of the State of West Virginia.
2. The State may accept or reject in part, or in whole, any bid.
3. All quotations are governed by the *West Virginia Code* and the *Legislative Rules* of the Purchasing Division.
4. Prior to any award, the apparent successful vendor must be properly registered with the Purchasing Division and have paid the required \$125.00 registration fee.
5. All services performed or goods delivered under State Purchase Orders/Contracts are to be continued for the term of the Purchase Order/Contract, contingent upon funds being appropriated by the Legislature or otherwise being made available. In the event funds are not appropriated or otherwise available for these services or goods, this Purchase Order/Contract becomes void and of no effect after June 30.
6. Payment may only be made after the delivery and acceptance of goods or services.
7. Interest may be paid for late payment in accordance with the *West Virginia Code*.
8. Vendor preference will be granted upon written request in accordance with the *West Virginia Code*.
9. The State of West Virginia is exempt from federal and state taxes and will not pay or reimburse such taxes.
10. The Director of Purchasing may cancel any Purchase Order/Contract upon 30 days written notice to the seller.
11. The laws of the State of West Virginia and the *Legislative Rules* of the Purchasing Division shall govern all rights and duties under the Contract, including without limitation the validity of this Purchase Order/Contract.
12. Any reference to automatic renewal is hereby deleted. The Contract may be renewed only upon mutual written agreement of the parties.
13. **BANKRUPTCY:** In the event the vendor/contractor files for bankruptcy protection, this Contract may be deemed null and void, and terminated without further order.
14. **HIPAA Business Associate Addendum -** The West Virginia State Government HIPAA Business Associate Addendum (BAA), approved by the Attorney General, and available online at the Purchasing Division's web site (<http://www.state.wv.us/admin/purchase/vrc/hipaa.htm>) is hereby made part of the agreement. Provided that, the Agency meets the definition of a Covered Entity (45 CFR §160.103) and will be disclosing Protected Health Information (45 CFR §160.103) to the vendor.

---

**INSTRUCTIONS TO BIDDERS**

1. Use the quotation forms provided by the Purchasing Division.
2. **SPECIFICATIONS:** Items offered must be in compliance with the specifications. Any deviation from the specifications must be clearly indicated by the bidder. Alternates offered by the bidder as **EQUAL** to the specifications must be clearly defined. A bidder offering an alternate should attach complete specifications and literature to the bid. The Purchasing Division may waive minor deviations to specifications.
3. Complete all sections of the quotation form.
4. Unit prices shall prevail in cases of discrepancy.
5. All quotations are considered F O B destination unless alternate shipping terms are clearly identified in the quotation.
6. **BID SUBMISSION:** All quotations must be delivered by the bidder to the office listed below prior to the date and time of the bid opening. Failure of the bidder to deliver the quotations on time will result in bid disqualifications.

**SIGNED BID TO:**

Department of Administration  
Purchasing Division  
2019 Washington Street East  
Post Office Box 50130  
Charleston, WV 25305-0130

## ADDENDUM #1

708EC004

## OPEN END CONTRACT

## 5 CUBIC YARD STAINLESS STEEL (HYDRAULIC) SPREADER

## CHANGES TO SPECIFICATIONS:

## FROM:

7.5.4 Tensile strength of each chain shall be 20,000 pounds minimum

## TO:

**7.5.4 Tensile strength of each chain shall be 21,000 pounds minimum**

## FROM:

7.5.10 Additional 7 gauge 304 stainless steel reinforcing plate to be welded to longitudinal webs covering area of drive shaft bearing and idler bearing adjustment.

## TO:

7.5.10 Additional 7 gauge 304 stainless steel reinforcing plate to be welded to longitudinal webs covering area of drive shaft bearing and idler bearing adjustment (if required).

## FROM:

7.5.13 Conveyor box must have its drive shaft extended through the rear of gear housing, and the shaft end machined to accommodate the application rate sensor shaft for the Dickey-John Automatic Control System, Model ICS-2000. The necessary oil seal included.

## TO:

**7.5.13 Conveyor gear box motor shall have an integral speed sensor**

## FROM:

7.6.3 Spinner shall be vertically adjustable approximately 16" and provide approximately a 20" to 32" spinner position below the mounting surface.

## TO:

**7.6.3 Spinner shall be vertically adjustable approximately 18 inches and provide approximately a 20 inch to 38 inch spinner position below the mounting surface.**

Addendum #1  
708EC004

FROM:

7.7.1 Baffles shall be provided to control direction and width of spread. To have four (4) sections over right, left, rear, and front of spinners.

TO:

7.7.1 **Baffles shall be provided to control direction and width of spread.** To have four (4) sections over right, left, rear, and front of spinners. Front spinner baffle shield (truck side) can be stationary.

FROM:

7.11 Lighting to be in accordance with the attached sketch

IO:

7.11 Lighting to be in accordance with the attached sketch and wiring schematic

FROM:

7.12.3 The truck central hydraulic system, supplied and installed by another vendor, will be complete to and including the rear manifold, located at the rear cross-member of truck. The rear manifold will have attached to it one (1) 3/4" I.D. pressure line with 3/4" quick disconnect, one (1) 1/2" I.D. pressure line with 1/2" quick disconnect, one (1) 1" I.D. return line with 1-1/4" quick disconnect. The quick disconnects will be "VH" series snap-tite. **The spreader vendor shall supply proper mating quick disconnects, metal caps, and plugs for connection to truck manifold.**

IO:

7.12.3 The truck central hydraulic system, supplied and installed by another vendor, will be complete to and including the rear manifold, located at the rear cross-member of truck. The rear manifold will have attached to it one (1) 3/4" I.D. pressure line with 3/4" quick disconnect, one (1) 1/2" I.D. pressure line with 1/2" quick disconnect, one (1) 1" I.D. return line with 1-1/4" quick disconnect. The quick disconnects will be "VH" series snap-tite. **The spreader vendor shall supply male quick disconnects, metal caps, and plugs for connection to truck manifold.**

Addendum #1  
708EC004

FROM:

**7.13 An anodized 6061T6 aluminum grease manifold block shall be mounted at the rear of the body incorporating the front bearing grease extension tubes, rear bearing grease fittings, and feedgate screw jack lubrication tube to allow for lubrication of the front bearings and feedgate screw jack from a single convenient location. Other fittings shall be placed at convenient location for normal maintenance.**

TO:

**7.13 An anodized 6061T6 aluminum or 304 stainless steel grease manifold block shall be mounted at the rear of the body incorporating the front bearing grease extension tubes, rear bearing grease fittings, and feedgate screw jack lubrication tube to allow for lubrication of the front bearings and feedgate screw jack from a single convenient location. Other fittings shall be placed at convenient location for normal maintenance.**

FROM:

**7.13.1 The anodized 6061T6 aluminum grease manifold block shall have a minimum of six (6) ports tapped to accept three (3) 1/8 inch straight grease zerks and three (3) 1/8 inch grease Parflex hoses to provide for adequate one location greasing of the front and rear bearings and feed gate screw jack. Any unused ports are to be properly plugged.**

TO:

**7.13.1 The anodized 6061T6 aluminum or 304 stainless steel grease manifold block shall have a minimum of six (6) ports tapped to accept three (3) 1/8 inch straight grease zerks and three (3) 1/8 inch grease Parflex hoses to provide for adequate one location greasing of the front and rear bearings and feed gate screw jack. Any unused ports are to be properly plugged.**

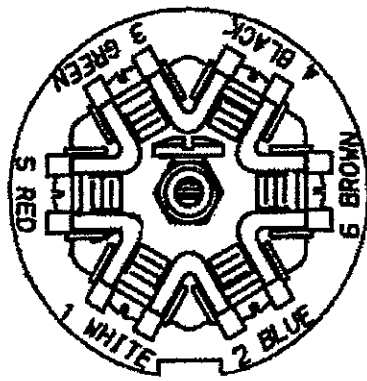

## Wiring Code 7 way Trailer End

#	Color	Gage	Circuit Function	connector interior
1	white	10	common ground	
2	blue	12	<i>STROBE</i>	
3	green	14	tail/running lights	
4	black	10	battery charge (+)	
5	red	14	left turn/stop	
6	brown	14	right turn/stop	
7	yellow	14	auxiliary/Work Lights	

10/23/2007

## ADDENDUM #1

708EC004

## OPEN END CONTRACT

## 5 CUBIC YARD STAINLESS STEEL (HYDRAULIC) SPREADER

## CHANGES TO BIDDER'S EVALUATION REPORT:

X7.5.4 NO CHANGE REQUIRED

Tensile strength of each chain: 21,000 pounds

FROM:

X7.5.7 Is a 10 gauge 304 stainless steel heavy duty replaceable conveyor plate at least 3/16" thick fitted?        YES        NO

TO:

X7.5.7 Is a 10 gauge 304 stainless steel heavy duty replaceable ~~conveyor~~ plate fitted?         YES        NO

FROM:

X7.5.10 Is additional 7 gauge 304 stainless steel reinforcing plate welded to longitudinal webs covering the area of the drive shaft, bearing, and idler bearing provided?        YES        NO

TO:

X7.5.10 Is additional 7 gauge 304 stainless steel reinforcing plate welded to longitudinal webs covering the area of the drive shaft, bearing, and idler bearing provided if required?         YES        NO

FROM:

X7.5.13 Does conveyor gear box have its drive shaft extended through rear of gear housing?        YES        NOIs the shaft end machined to accommodate the application rate sensor shaft for the Dickey-John Automatic Control System, Model ICS-2000?        YES        NOIs the necessary oil seal included?        YES        NO

TO:

X7.5.13 Does the conveyor gear box motor have an integral speed sensor ?         YES        NO

Addendum #1  
708EC004

FROM:

X7.6.3 Is the spinner vertically adjustable to a full 16 inches?  YES  NO  
And  inch spinner position below mounting surface?

TO:

X7.6.3 Spinner is vertically adjustable 18 inches and provides a 20-38 inch spinner position below the mounting surface.

FROM:

X7.7.1 Are baffles provided to control direction and width of spread?  YES  NO

X7.7.1.2 Are there four (4) sections over right, left, rear and front of spinners?  YES  NO

TO:

X7.7.1 Are baffles provided to control direction and width of spread  YES  NO

X7.7.1.2 Are there four (4) sections over right, left, rear and front of spinners  
 YES  NO

Is front spinner baffle shield (truck side) stationary  YES  NO

FROM:

X7.11 Is lighting in accordance with the attached sketch?  YES  NO

TO:

X7.11 Is lighting in accordance with the attached sketch and wiring schematic?  
 YES  NO

Addendum #1  
708EC004

FROM:

X7.12.3 Will the hoses mate with the quick disconnects on the central hydraulic system of the truck?  YES  NO  
Will you furnish proper mating quick disconnects, metal caps, and plugs for connection to truck manifold?  YES  NO

TO:

X7.12.3 Will the hoses mate with the quick disconnects on the central hydraulic system of the truck?  YES  NO  
Will you furnish the male quick disconnects, metal caps, and plugs for connection to truck manifold?  YES  NO

FROM:

X7.13 Is an anodized 6061T6 aluminum grease manifold block mounted at the rear of the body which incorporates the front bearing grease extension tubes, rear bearing grease fittings and feedgate screw jack lubrication tube?  YES  NO

TO:

X7.13 Is an anodized 6061T6 aluminum  YES  NO  
(OR)  
304 stainless steel  YES  NO grease manifold block mounted at the rear of the body which incorporates the front bearing grease extension tubes, rear bearing grease fittings and feedgate screw jack lubrication tube?  YES  NO

FROM:

X7.13.1 Are all other fittings placed at convenient locations for normal maintenance?  YES  NO  
Number of grease manifold block ports: \_\_\_\_\_

TO:

X7.13.1 The anodized 6061T6 aluminum  YES  NO  
(OR)  
304 stainless steel grease manifold block  YES  NO has 6 ports tapped to accept three (3) 1/8 inch straight grease zerks and three (3) 1/8 inch grease Parflex hoses to provide for adequate one location greasing of the front and rear bearings and feed gate screw jack  YES  NO  
Are any unused ports properly plugged  YES  NO

SIGN IN SHEET

RFQ # 708EC004  
Date: 10/26/07

Firm & Representative Name:

Mailing Address:

Phone, Fax, & E-Mail:

1. BONNELL INDUSTRIES  
JOE HOOVER

1385 FRANKLIN GROVE RD.  
DIXON, IL 61021

P 800-851-9664  
815-284-3819  
F 815-284-8815

E-mail \_\_\_\_\_

2. LV TRACTOR  
GARY GRADY

P.O. BOX 473  
CHARLESTON WV  
25322

P 346-5301  
F 346-5305

E-mail lvtractor@usa.com

3. Benson International  
Bubba Smith

6151 New England Ridge Rd  
Washington WV 26181

P 304-483-7093  
F 304-863-3629

E-mail Bsmith@bensonintl.com

4. Gregi Moore

DOT

P 304 558-9427

F \_\_\_\_\_

E-mail \_\_\_\_\_

5. George Bailey

PO Box 127  
Lindenwood, IL 61049

P 815-393-4455

F \_\_\_\_\_

E-mail George@Sawsonspandea.com

Please print or write legibly!

Your fax # is essential to contact you timely!

SIGN IN SHEET

RFQ # \_\_\_\_\_

Date: \_\_\_\_\_

Firm & Representative Name:

Mailing Address:

Phone, Fax, & E-Mail:

1. Len Hancock  
LH Trng Equip

1825 EARL CURR RD.  
Morgan Ln 26505

P 292 1307  
F 292 6641

E-mail LENO@LHTRNG.COM

2. RONALD KESSLER  
MONROE T/E

1051 W 7TH ST  
MONROE, LA 70506

P 800-880-0109  
F 608-328-8390

E-mail DGETZBER@MONROE  
TRUCK.COM

3. Zach Marsh  
Middletown Tractor Sales

2032 Fairmont Ave.  
Fairmont WV 26554

P 304-366-4690  
F 304-366-4688

E-mail Zach@MiddletownTractor.com

4. Mike Shaver  
\_\_\_\_\_

2032 Fairmont Ave.  
Fairmont WV 26554

P 304-366-4690  
F 304-366-4698

E-mail Mike@Middletowntactor  
com

5. Kewal Pachwan  
Darubesse

DOH  
\_\_\_\_\_

P \_\_\_\_\_  
F \_\_\_\_\_

E-mail \_\_\_\_\_

Please print or write legibly!

Your fax # is essential to contact you timely!

### SIGN IN SHEET

RFQ # \_\_\_\_\_

Date: \_\_\_\_\_

Firm & Representative Name:

Mailing Address:

Phone, Fax, & E-Mail:

1. Logan Corporation  
Joe Dinaldo

Rt. 2 Box 924  
Clarksburg, WV 26301

P 304-641-2011  
F 304-623-5676

E-mail jdinaldo@LoganCorp.com

2. \_\_\_\_\_

\_\_\_\_\_

P \_\_\_\_\_

\_\_\_\_\_

\_\_\_\_\_

F \_\_\_\_\_

E-mail \_\_\_\_\_

3. \_\_\_\_\_

\_\_\_\_\_

P \_\_\_\_\_

\_\_\_\_\_

\_\_\_\_\_

F \_\_\_\_\_

E-mail \_\_\_\_\_

4. \_\_\_\_\_

\_\_\_\_\_

P \_\_\_\_\_

\_\_\_\_\_

\_\_\_\_\_

F \_\_\_\_\_

E-mail \_\_\_\_\_

5. \_\_\_\_\_

\_\_\_\_\_

P \_\_\_\_\_

\_\_\_\_\_

\_\_\_\_\_

F \_\_\_\_\_

E-mail \_\_\_\_\_

Please print or write legibly!

Your fax # is essential to contact you timely!



State of West Virginia  
 Department of Administration  
 Purchasing Division  
 2019 Washington Street East  
 Post Office Box 50130  
 Charleston, WV 25305-0130

**Request for Quotation**

RFQ NUMBER:  
 708EC004

PAGE:  
 1

ADDRESS CORRESPONDENCE TO ATTENTION OF:  
 MICHAEL AUSTIN  
 304-558-2402

\*709043957 01 304-292-1307  
 L H JONES EQUIP CO  
 1825 EARL CORE ROAD  
 MORGANTOWN WV 26505

DIVISION OF HIGHWAYS  
 EQUIPMENT DIVISION  
 ROUTE 33  
 BRUSHY FORK ROAD  
 BUCKHANNON, WV  
 26201 304-472-1111

PROPERTY

SHIP TO

DATE PRINTED 11/14/2007	TERMS OF SALE <i>Net 30 Days</i>	SHIP VIA <i>Motor Freight</i>	FOB <i>Buckhannon WV</i>	FREIGHT TERMS <i>No charge</i>
BID OPENING DATE: 11/20/2007	BID OPENING TIME 01:30PM			

LINE	QUANTITY	UOP	CAT NO	ITEM NUMBER	UNIT PRICE	AMOUNT
				ADDENDUM NO. 2 CHANGES TO THE SPECIFICATIONS 6.5 - WARRANTY AND SERVICE POLICY DISREGARD LAST PARAGRAPH.  X6.5 WARRANTY AND SERVICE POLICY QUESTIONNAIRE PAGE 25 MUST BE COMPLETED AND SUBMITTED WITH THE BID.  BID OPENING DATE AND TIME CHANGED FROM: 11/13/07 AT 1:30 P.M. TO: 11/20/07 AT 1:30 P.M.  NO OTHER CHANGES		
0001	1	EA		765-66		
				FIVE CUBIC YARD STAINLESS STEEL (HYDRAULIC) SPREADER  EXHIBIT 10  REQUISITION NO.: <i>708EC004</i>  ADDENDUM ACKNOWLEDGEMENT		

*See Page 27 of R.B.I.*

SEE REVERSE SIDE FOR TERMS AND CONDITIONS

SIGNATURE: *[Signature]* TELEPHONE: *304 792 1307* DATE: *11/14/07*

TITLE: *[Signature]* FEIN: *55-0551865* ADDRESS CHANGES TO BE NOTED ABOVE

WHEN RESPONDING TO RFQ, INSERT NAME AND ADDRESS IN SPACE ABOVE LABELED 'VENDOR'





State of West Virginia  
Department of Administration  
Purchasing Division  
2019 Washington Street East  
Post Office Box 50130  
Charleston, WV 25305-0130

# Request for Quotation

RFQ NUMBER: 708EC004

PAGE: 2

ADDRESS CORRESPONDENCE TO ATTENTION OF:  
MICHAEL AUSTIN  
304-558-2402

\*709043957 01 304-292-1307  
L H JONES EQUIP CO  
1825 EARL CORE ROAD  
MORGANTOWN WV 26505

MORGANTOWN

SHIP TO

DIVISION OF HIGHWAYS  
EQUIPMENT DIVISION  
ROUTE 33  
BRUSHY FORK ROAD  
BUCKHANNON, WV  
26201 304-472-1111

DATE PRINTED 11/14/2007	TERMS OF SALE	SHIP VIA	F.O.B.	FREIGHT TERMS
BID OPENING DATE: 11/20/2007			BID OPENING TIME	01:30PM

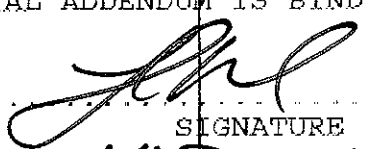
LINE	QUANTITY	UOP	CAT NO	ITEM NUMBER	UNIT PRICE	AMOUNT
<p>I HEREBY ACKNOWLEDGE RECEIPT OF THE FOLLOWING CHECKED ADDENDUM(S) AND HAVE MADE THE NECESSARY REVISIONS TO MY PROPOSAL, PLANS AND/OR SPECIFICATION, ETC.</p> <p>ADDENDUM NO.'S:</p> <p>NO. 1 ✓</p> <p>NO. 2 ✓</p> <p>NO. 3</p> <p>NO. 4</p> <p>NO. 5</p> <p>I UNDERSTAND THAT FAILURE TO CONFIRM THE RECEIPT OF THE ADDENDUM(S) MAY BE CAUSE FOR REJECTION OF BIDS.</p> <p>VENDOR MUST CLEARLY UNDERSTAND THAT ANY VERBAL REPRESENTATION MADE OR ASSUMED TO BE MADE DURING ANY ORAL DISCUSSION HELD BETWEEN VENDOR'S REPRESENTATIVES AND ANY STATE PERSONNEL IS NOT BINDING. ONLY THE INFORMATION ISSUED IN WRITING AND ADDED TO THE SPECIFICATIONS BY AN OFFICIAL ADDENDUM IS BINDING.</p> <p style="text-align: right;">             SIGNATURE            L.H. Jones Equipment Co.            COMPANY            11/14/07            DATE         </p>						

SEE REVERSE SIDE FOR TERMS AND CONDITIONS

SIGNATURE 	TELEPHONE 304 792 1302	DATE 11/14/07
TITLE VP	FEIN 55-0551865	ADDRESS CHANGES TO BE NOTED ABOVE

WHEN RESPONDING TO RFQ, INSERT NAME AND ADDRESS IN SPACE ABOVE LABELED 'VENDOR'



State of West Virginia  
 Department of Administration  
 Purchasing Division  
 2019 Washington Street East  
 Post Office Box 50130  
 Charleston, WV 25305-0130

# Request for Quotation

RFQ NUMBER
708EC004

PAGE
3

ADDRESS CORRESPONDENCE TO ATTENTION OF
MICHAEL AUSTIN 304-558-2402

\*709043957 01 304-292-1307

L H JONES EQUIP CO  
 1825 EARL CORE ROAD

MORGANTOWN WV 26505

VENDOR

SHIP TO

DIVISION OF HIGHWAYS  
 EQUIPMENT DIVISION  
 ROUTE 33  
 BRUSHY FORK ROAD  
 BUCKHANNON, WV  
 26201 304-472-1700

DATE PRINTED	TERMS OF SALE	SHIP VIA	FOB	FREIGHT TERMS
11/14/2007				
BID OPENING DATE: 11/20/2007		BID OPENING TIME 01:30PM		

LINE	QUANTITY	UOP	CAT NO	ITEM NUMBER	UNIT PRICE	AMOUNT
	REV. 11/96					
***** THIS IS THE END OF RFQ 708EC004 ***** TOTAL:						

*See Pg. 27 of the Bid.*

SEE REVERSE SIDE FOR TERMS AND CONDITIONS

SIGNATURE	TELEPHONE	DATE
TITLE	FEIN	ADDRESS CHANGES TO BE NOTED ABOVE

WHEN RESPONDING TO RFQ, INSERT NAME AND ADDRESS IN SPACE ABOVE LABELED 'VENDOR'



1825 Earl Core Road  
Morgantown WV 26505  
Local Phone: 304-292-1307  
Toll Free: 888-292-1305  
Fax: 304-292-6641  
www.lhjones.com

November 14, 2007

Mr. Michael Austin  
State of West Virginia  
Department of Administration  
Purchasing Division  
2019 Washington Street East  
P.O. Box 50130  
Charleston, WV 25305-0130

Dear Mr. Austin:

This letter, included as part of L.H. Jones Equipment Company's response to RFQ# 708EC004 serves to address issues on pages one to eight of the RFQ which are at the option of the successful bidder as well as indicate LH Jones Equipment Company's full compliance to the specification.

First, as per Exhibit 6, L.H. Jones Equipment Company hereby requests a Price Adjustment Provision as per the RFQ. As stated in the RFQ, the price adjustment provision will cover "both upward and downward movement" and any adjustments will be "based on the 'pass through' increase or decrease of raw materials and/or labor." Any adjustments that are submitted will be as an "actual dollar figure" as described.

Second, as per Exhibit 4, L.H. Jones Equipment Company hereby declines to extend bid prices, terms, and conditions of the bid to county, school, municipal and other local government bodies. Unfortunately, the low volume purchases typically made by such agencies do not allow the manufacturer to recoup their costs associated with such purchases.

In addition, the unit with which LH Jones Equipment Company is responding to the specification complies fully to every specification. Any indication contrary to the specification on any of the bid documents is a mistake and must be disregarded.

If you have any questions or require additional information, please do not hesitate to contact me at your convenience.

Regards,

A handwritten signature in black ink, appearing to read "LH", written over a white background.

Leonard "Len" Hancock Jr.  
Vice President



**HOME PRODUCTS FIND A DISTRIBUTOR** by **Buyers** PRODUCTS COMPANY

## 7, 8 AND 9 YARD STAINLESS STEEL SALT & SAND SPREADERS

**IDEAL FOR HEAVY DUTY MUNICIPAL & COMMERCIAL APPLICATIONS.**  
*Designed for municipalities and contractors with a minimum 26,000 lbs. GVW chassis.*

**GENERAL:**

- Self-contained hopper.
- Spreads free flowing materials sand and/or salt.
- Spread width of 4' to 40'.

**MATERIAL HOPPER:**

- 7-gauge 304 stainless steel cross members.
- 10-gauge 304 stainless steel, long sills with rear enclosure & integral chain shields.
- 10-gauge 304 stainless steel replaceable floor.
- 10-gauge 304 stainless steel sides (continuously welded seams), gussets and rear panel.
- 10-gauge 304 stainless steel front panel.
- Four (4) 5/8" thick lift points.

**FEEDGATE:**

- 10-gauge, 304 stainless steel with scaled screw jack adjustment.
- 18-5/8" wide x 10" tall opening.

**CONVEYOR:**

- 24" wide, pintle chain conveyor with 3/8" thick x 1-1/2" wide crossbars on 4-1/2" centers (667X Pitch).
- 2" diameter drive shaft with 4-bolt relubeable bearing.
- 8-tooth cast iron sprockets.
- 50:1 or 25:1 direct-drive gearbox with extended through-shaft for ground speed sensor.
- 1-1/2" diameter idler shaft with 4" adjustable range relubeable bearing.
- Conveyor chain wiper made of belted rubber minimizes waste

**STANDARD INSTALLED EQUIPMENT:**

- 4-section hinged top grate screens. 3/8" diameter bar on 3" centers with 1/4" x 2" x 2" angle iron frame. Hinged to 6" horizontal crossbeam.
- 10-gauge, 304 stainless steel inverted "V" prevents material compaction and reduces wear on drive train components.

**CHUTE/SPINNER ASSEMBLY:**

- 10-gauge, 304 stainless steel laser cut parts with smooth radius corners.
- Telescopic adjustment in 3" increments to accommodate varying body mounting heights.



Copyright© 2006 | All Rights Reserved by SaltDogg | Site by the Dudash Factory

**CHUTE/SPINNER ASSEMBLY:**

- 10-gauge, 304 stainless steel laser cut parts with smooth radius corners
- Telescopic adjustment in 3" increments to accommodate varying body mounting heights.
- Two (2) adjustable, internal baffles direct material to 20" diameter x 5/8" thick, 6-fin poly spinner disc.
- Three (3) adjustable external and one (1) fixed deflector with overlapping corners provide a precision spread pattern.
- Top-mounted, direct-drive hydraulic spinner motor provides better ground clearance and corrosion protection.
- Two (2) stainless steel spring latches quick release hinged chute for bulk material unloading and convenient ground storage.

**POWER SOURCE:**

- Hydraulic Drive: Two independent direct drive hydraulic motors (17 GPM @ 1,500 PSI).

**OPTIONAL EQUIPMENT:**

- Dump Body Tailgate Latch Kit (Part # 3008560).
- DOT Spreader Lightbar (Part # LB8663SST). 8" Tall x 66" Long x 3" Deep stainless steel lightbar includes 9 mounting holes for 4" recessed stop-turn-taillights-strobes and 2-1/2" marker lights.
- Liquid Spray System (Part # LS4), 104 Gallons.
- Tie-Down Kit (Part # 3010548).

**DIMENSIONS:**

- Hopper length, 120"; Overall length, 143"; Width, 82"
- Recommended use, dump bodies and flat beds with a minimum 26,000 lbs. GVW chassis.

*Buyers Products Company reserves the right to change material, dimension and/or component specifications without notice.*

Part No.	Drive	Gearbox Ratio	Cubic Yards (level)	Cubic Yards (rounded)	Side Height	Weight
1450757SSH	Hydraulic	50:1	7	8.3	57	2,310 lbs.
1425757SSH	Hydraulic	25:1	7	8.3	57	2,310 lbs.
1450863SSH	Hydraulic	50:1	8.3	9.6	63	2,457 lbs.
1425863SSH	Hydraulic	25:1	8.3	9.6	63	2,457 lbs.
1450969SSH	Hydraulic	50:1	9.6	12.2	69	2,550 lbs.
1425969SSH	Hydraulic	25:1	9.6	12.2	69	2,550 lbs.

## Gear Box, Sprockets Assembly

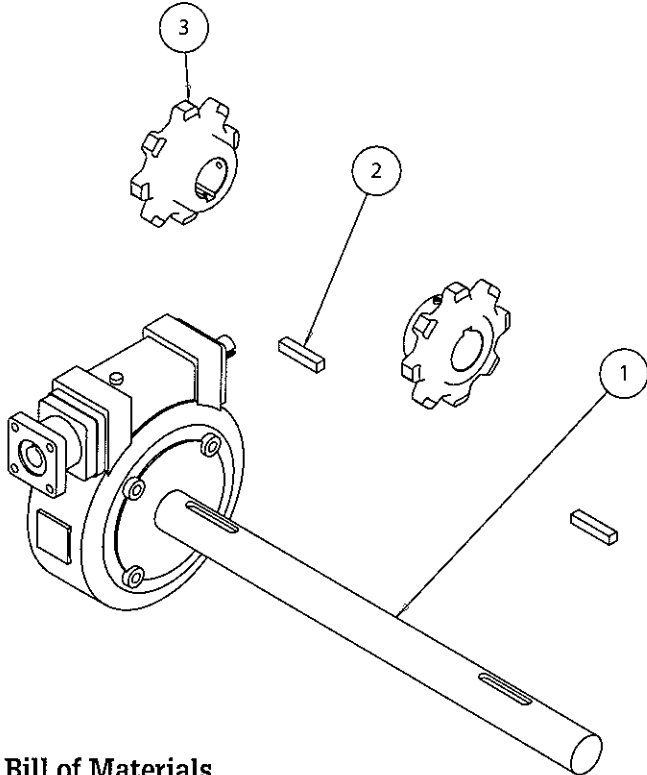

### Bill of Materials

ITEM	PART NO.	QTY.	DESCRIPTION
1	3010863	1	Gear Box 25:1 Left Hand
1	3010057	1	Gear Box 50:1 Left Hand
2	3010989	2	Key Square, 1/2" x 2 1/2"
3	3010845	2	Sprocket Drive Assembly

## Idler Shaft Assembly

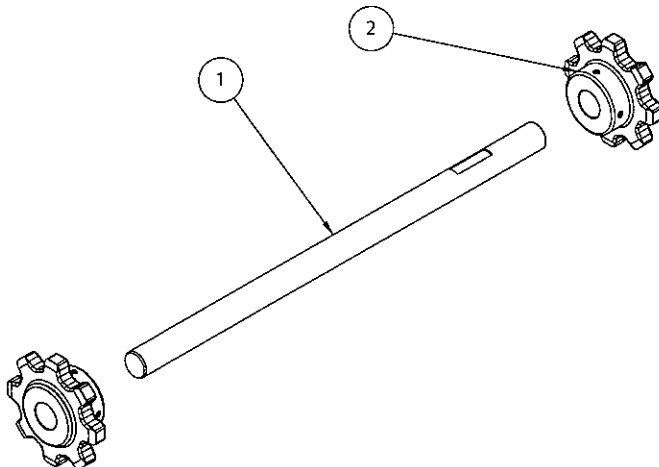

### Bill of Materials

ITEM	PART NO.	QTY.	DESCRIPTION
1	3010034	1	Shaft, Idler 28" long
2	3010846	2	Sprocket Idler Assembly

## Spinner Disc Assembly

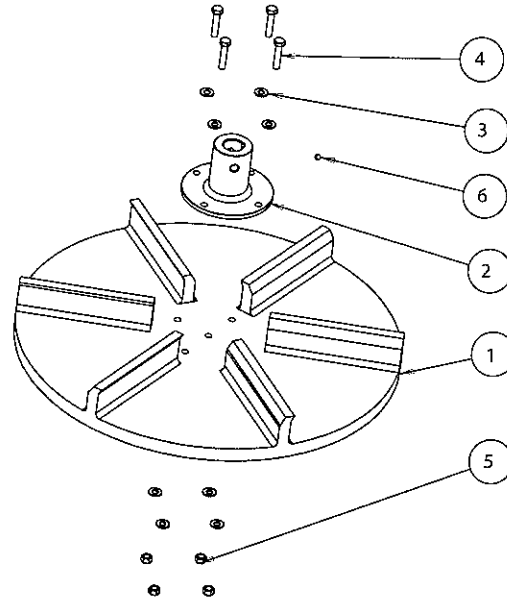

### Bill of Materials

ITEM	PART NO.	QTY.	DESCRIPTION
1	9240020	1	Spinner, 20" Poly CCW
2	3008632	1	Hub, Long Neck Spinner
3	-	8	Washer, 5/16 SAE SST
4	-	4	Screw, HHC 5/16-18 x 1 1/2 Gr 5 SS
5	-	4	Nut, Nylock 5/16-18 SS
6	-	1	Screw, Set SOC Cup Point 1/4-20 x 1/4 SS

### SPREADER WARRANTY INFORMATION

This warranty replaces all previous warranties and no employee of this company is authorized to extend additional warranties, or agreements, or implications not explicitly covered herein.

Buyers Products Company warrants all parts of the product to be free from defects in material and workmanship for a period of ~~one (1) year~~ *2 years*. Parts must be properly installed and used under normal conditions. Normal wear is excluded.

Any part which has been altered, including modifications, misuse, accident, or lack of maintenance will not be considered under this warranty.

The sole responsibility of Buyers Products Company under this warranty is limited to repairing or replacing any part(s) which are returned, prepaid, 30 days after such defect is discovered, and returned part(s) are found to be defective by Buyers Products Company.

Authorization from Buyers Products Company must be obtained before returning any part. The following information must accompany defective parts returned to Buyers Products Company: RMA#, spreader model, serial number, date installed, and distributor from whom purchased.

Buyers Products Company shall not be liable for damage arising out of failure of any unit to operate properly, or failure, or delay in work, or for any consequential damages. No charges for transportation or labor performed on any part will be allowed under this warranty.



State of West Virginia  
 Department of Administration  
 Purchasing Division  
 2019 Washington Street East  
 Post Office Box 50130  
 Charleston, WV 25305-0130

# Request for Quotation

RFQ NUMBER
708EC004

PAGE
1

ADDRESS CORRESPONDENCE TO ATTENTION OF:
MICHAEL AUSTIN 304-558-2402

\*709043957 01 304-292-1307  
 L H JONES EQUIP CO  
 1825 EARL CORE ROAD  
 MORGANTOWN WV 26505

VENDOR

SHIP TO

DIVISION OF HIGHWAYS  
 EQUIPMENT DIVISION  
 ROUTE 33  
 BRUSHY FORK ROAD  
 BUCKHANNON, WV  
 26201 304-472-1750

DATE PRINTED 11/14/2007	TERMS OF SALE <i>Net 30 Days</i>	SHIP VIA <i>Moby freight</i>	F.O.B. <i>Buckhannon, WV</i>	FREIGHT TERMS <i>No Charge</i>
BID OPENING DATE: 11/20/2007	BID OPENING TIME			01:30PM

LINE	QUANTITY	UOP	CAT NO	ITEM NUMBER	UNIT PRICE	AMOUNT
				ADDENDUM NO. 3		
				X6.5 WARRANTY AND SERVICE POLICY QUESTIONNAIRE		
				IF THE ORIGINAL BID HAS BEEN SUBMITTED TO THE PURCHASING DIVISION PREVIOUSLY, BIDDERS MAY SUBMIT PAGE 25 WITH THE ADDENDUM TO THE PURCHASING DIVISION FOR BID OPENING 11/20/07 AT 1:30 P.M. IN A SEPARATE SEALED ENVELOPE.		
				NO OTHER CHANGES		
0001	1	EA		765-66	<i>See Page</i>	<i>27 of bid</i>
				FIVE CUBIC YARD STAINLESS STEEL (HYDRAULIC) SPREADER		
				EXHIBIT 10		
				REQUISITION NO. : <i>708EC004</i>		
				ADDENDUM ACKNOWLEDGEMENT		
				I HEREBY ACKNOWLEDGE RECEIPT OF THE FOLLOWING CHECKED ADDENDUM(S) AND HAVE MADE THE NECESSARY REVISIONS TO MY PROPOSAL, PLANS AND/OR SPECIFICATION, ETC.		
				ADDENDUM NO. 'S:		

SEE REVERSE SIDE FOR TERMS AND CONDITIONS		
SIGNATURE <i>[Signature]</i>	TELEPHONE <i>304 292 1307</i>	DATE <i>11/19/07</i>
TITLE <i>VP</i>	FEIN <i>55-0551865</i>	ADDRESS CHANGES TO BE NOTED ABOVE

WHEN RESPONDING TO RFQ, INSERT NAME AND ADDRESS IN SPACE ABOVE LABELED 'VENDOR'



State of West Virginia  
 Department of Administration  
 Purchasing Division  
 2019 Washington Street East  
 Post Office Box 50130  
 Charleston, WV 25305-0130

# Request for Quotation

RFO NUMBER
708EC004

PAGE
2

ADDRESS CORRESPONDENCE TO ATTENTION OF
MICHAEL AUSTIN 304-558-2402

\*709043957 01 304-292-1307  
 L H JONES EQUIP CO  
 1825 EARL CORE ROAD  
 MORGANTOWN WV 26505

VENDOR

SHIP TO

DIVISION OF HIGHWAYS  
 EQUIPMENT DIVISION  
 ROUTE 33  
 BRUSHY FORK ROAD  
 BUCKHANNON, WV  
 26201 304-472-1750

DATE PRINTED 11/14/2007	TERMS OF SALE	SHIP VIA	F.O.B.	FREIGHT TERMS
BID OPENING DATE: 11/20/2007		BID OPENING TIME 01:30PM		

LINE	QUANTITY	UOP	CAT NO.	ITEM NUMBER	UNIT PRICE	AMOUNT
NO. 1	✓					
NO. 2	✓					
NO. 3	✓					
NO. 4						
NO. 5						
<p>I UNDERSTAND THAT FAILURE TO CONFIRM THE RECEIPT OF TH ADDENDUM(S) MAY BE CAUSE FOR REJECTION OF BIDS.</p> <p>VENDOR MUST CLEARLY UNDERSTAND THAT ANY VERBAL REPRESENTATION MADE OR ASSUMED TO BE MADE DURING ANY ORAL DISCUSSION HELD BETWEEN VENDOR'S REPRESENTATIVES AND ANY STATE PERSONNEL IS NOT BINDING. ONLY THE INFORMATION ISSUED IN WRITING AND ADDED TO THE SPECIFICATIONS BY AN OFFICIAL ADDENDUM IS BINDING.</p>						
<p>.....            SIGNATURE  <i>LH Jones Equip Co.</i>            COMPANY            11/19/07            DATE</p>						
REV. 11/96						

SEE REVERSE SIDE FOR TERMS AND CONDITIONS		
SIGNATURE	TELEPHONE	DATE
TITLE	FEIN	ADDRESS CHANGES TO BE NOTED ABOVE

WHEN RESPONDING TO RFQ, INSERT NAME AND ADDRESS IN SPACE ABOVE LABELED 'VENDOR'