



State of West Virginia
 Department of Administration
 Purchasing Division
 2019 Washington Street East
 Post Office Box 50130
 Charleston, WV 25305-0130

Request for Quotation

RFQ NUMBER
708C0023

PAGE
1

ADDRESS CORRESPONDENCE TO ATTENTION OF
MICHAEL AUSTIN
304-558-2402

RFQ COPY

TYPE NAME/ADDRESS HERE

Electronic Communications of WV
408 Old Goff Main Road
CROSS LANES WV 25313

DIVISION OF HIGHWAYS
 VARIOUS LOCALES AS INDICATED
 BY ORDER

DATE PRINTED 05/01/2008	TERMS OF SALE Net 30 Day	SHIP VIA Best way	FOB Dest	FREIGHT TERMS Shipper
BID OPENING DATE: 05/14/2008		BID OPENING TIME 01:30PM		

LINE	QUANTITY	UOP	CAT NO	ITEM NUMBER	UNIT PRICE	AMOUNT
0001	1	EA		120-50	171.00	171.00
<p>LED BEACONS OR EQUAL</p> <p>OPEN END CONTRACT</p> <p>PROVIDE LED BEACONS OR EQUAL WHICH MAY BE REQUIRED BY THE WV DIVISION OF HIGHWAYS PER THE ATTACHED SPECIFICATIONS.</p> <p>THE MODEL/BRAND/SPECIFICATIONS NAMED HEREIN ESTABLISH THE ACCEPTABLE LEVEL OF QUALITY ONLY AND ARE NOT INTENDED TO REFLECT A PREFERENCE OR FAVOR ANY PARTICULAR BRAND OR VENDOR. VENDORS WHO ARE BIDDING ALTERNATES SHOULD SO STATE AND INCLUDE PERTINENT LITERATURE AND SPECIFICATIONS. FAILURE TO PROVIDE INFORMATION FOR ANY ALTERNATES MAY BE GROUNDS FOR REJECTION OF THE BID. THE STATE RESERVES THE RIGHT TO WAIVE MINOR IRREGULARITIES IN BIDS OR SPECIFICATIONS IN ACCORDANCE WITH SECTION 148-1-4(F) OF THE WEST VIRGINIA LEGISLATIVE RULES AND REGULATIONS.</p> <p>EXHIBIT 3</p> <p>LIFE OF CONTRACT: THIS CONTRACT BECOMES EFFECTIVE ON AND EXTENDS FOR A PERIOD OF ONE (1) YEAR OR UNTIL SUCH "REASONABLE TIME" THEREAFTER AS IS NECESSARY TO OBTAIN A NEW CONTRACT OR RENEW THE ORIGINAL CONTRACT. THE "REASONABLE TIME" PERIOD SHALL NOT EXCEED TWELVE (12) MONTHS. DURING THIS "REASONABLE TIME" THE VENDOR MAY TERMINATE THIS CONTRACT FOR ANY</p>						

08 MAY 14 AM 9:14
 PURCHASING DIVISION
 STATE OF WV

SEE REVERSE SIDE FOR TERMS AND CONDITIONS

SIGNATURE: *Thomas E Ford* TELEPHONE: **304-776-4091** DATE: **MAY 14 2008**

TITLE: **President** FEIN: **55 052 0004** ADDRESS CHANGES TO BE NOTED ABOVE

WHEN RESPONDING TO RFQ, INSERT NAME AND ADDRESS IN SPACE ABOVE LABELED 'VENDOR'

**GENERAL TERMS & CONDITIONS
REQUEST FOR QUOTATION (RFQ) AND REQUEST FOR PROPOSAL (RFP)**

1. Awards will be made in the best interest of the State of West Virginia.
2. The State may accept or reject in part, or in whole, any bid.
3. All quotations are governed by the *West Virginia Code* and the *Legislative Rules* of the Purchasing Division.
4. Prior to any award, the apparent successful vendor must be properly registered with the Purchasing Division and have paid the required \$125.00 registration fee.
5. All services performed or goods delivered under State Purchase Orders/Contracts are to be continued for the term of the Purchase Order/Contract, contingent upon funds being appropriated by the Legislature or otherwise being made available. In the event funds are not appropriated or otherwise available for these services or goods, this Purchase Order/Contract becomes void and of no effect after June 30.
6. Payment may only be made after the delivery and acceptance of goods or services.
7. Interest may be paid for late payment in accordance with the *West Virginia Code*.
8. Vendor preference will be granted upon written request in accordance with the *West Virginia Code*.
9. The State of West Virginia is exempt from federal and state taxes and will not pay or reimburse such taxes.
10. The Director of Purchasing may cancel any Purchase Order/Contract upon 30 days written notice to the seller.
11. The laws of the State of West Virginia and the *Legislative Rules* of the Purchasing Division shall govern all rights and duties under the Contract, including without limitation the validity of this Purchase Order/Contract.
12. Any reference to automatic renewal is hereby deleted. The Contract may be renewed only upon mutual written agreement of the parties.
13. **BANKRUPTCY:** In the event the vendor/contractor files for bankruptcy protection, this Contract may be deemed null and void, and terminated without further order.
14. **HIPAA Business Associate Addendum** - The West Virginia State Government HIPAA Business Associate Addendum (BAA), approved by the Attorney General, and available online at the Purchasing Division's web site (<http://www.state.wv.us/admin/purchase/vrc/hipaa.htm>) is hereby made part of the agreement. Provided that, the Agency meets the definition of a Covered Entity (45 CFR §160.103) and will be disclosing Protected Health Information (45 CFR §160.103) to the vendor.

INSTRUCTIONS TO BIDDERS

1. Use the quotation forms provided by the Purchasing Division.
2. **SPECIFICATIONS:** Items offered must be in compliance with the specifications. Any deviation from the specifications must be clearly indicated by the bidder. Alternates offered by the bidder as **EQUAL** to the specifications must be clearly defined. A bidder offering an alternate should attach complete specifications and literature to the bid. The Purchasing Division may waive minor deviations to specifications.
3. Complete all sections of the quotation form.
4. Unit prices shall prevail in cases of discrepancy.
5. All quotations are considered F O B. destination unless alternate shipping terms are clearly identified in the quotation.
6. **BID SUBMISSION:** All quotations must be delivered by the bidder to the office listed below prior to the date and time of the bid opening. Failure of the bidder to deliver the quotations on time will result in bid disqualifications.

SIGNED BID TO:

Department of Administration
Purchasing Division
2019 Washington Street East
Post Office Box 50130
Charleston, WV 25305-0130



State of West Virginia
 Department of Administration
 Purchasing Division
 2019 Washington Street East
 Post Office Box 50130
 Charleston, WV 25305-0130

Request for Quotation

RFQ NUMBER
 708C0023

PAGE
 2

ADDRESS CORRESPONDENCE TO ATTENTION OF
 MICHAEL AUSTIN
 304-558-2402

RFQ COPY

TYPE NAME/ADDRESS HERE

Electronic Communications of WV
 408 Old Golf Mt Road
 Cross Lanes WV 25313

DIVISION OF HIGHWAYS
 VARIOUS LOCALES AS INDICATED
 BY ORDER

DATE PRINTED	TERMS OF SALE	SHIP VIA	F.O.B.	FREIGHT TERMS
05/01/2008				

BID OPENING DATE: 05/14/2008 BID OPENING TIME 01:30PM

LINE	QUANTITY	UOP	CAT NO	ITEM NUMBER	UNIT PRICE	AMOUNT
<p>REASON UPON GIVING THE DIRECTOR OF PURCHASING 30 DAYS WRITTEN NOTICE.</p> <p>UNLESS SPECIFIC PROVISIONS ARE STIPULATED ELSEWHERE IN THIS CONTRACT DOCUMENT, THE TERMS, CONDITIONS AND PRICING SET HEREIN ARE FIRM FOR THE LIFE OF THE CONTRACT.</p> <p>RENEWAL: THIS CONTRACT MAY BE RENEWED UPON THE MUTUAL WRITTEN CONSENT OF THE SPENDING UNIT AND VENDOR, SUBMITTED TO THE DIRECTOR OF PURCHASING THIRTY (30) DAYS PRIOR TO THE EXPIRATION DATE. SUCH RENEWAL SHALL BE IN ACCORDANCE WITH THE TERMS AND CONDITIONS OF THE ORIGINAL CONTRACT AND SHALL BE LIMITED TO TWO (2) ONE (1) YEAR PERIODS.</p> <p>CANCELLATION: THE DIRECTOR OF PURCHASING RESERVES THE RIGHT TO CANCEL THIS CONTRACT IMMEDIATELY UPON WRITTEN NOTICE TO THE VENDOR IF THE COMMODITIES AND/OR SERVICES SUPPLIED ARE OF AN INFERIOR QUALITY OR DO NOT CONFORM TO THE SPECIFICATIONS OF THE BID AND CONTRACT HEREIN.</p> <p>OPEN MARKET CLAUSE: THE DIRECTOR OF PURCHASING MAY AUTHORIZE A SPENDING UNIT TO PURCHASE ON THE OPEN MARKET, WITHOUT THE FILING OF A REQUISITION OR COST ESTIMATE, ITEMS SPECIFIED ON THIS CONTRACT FOR IMMEDIATE DELIVERY IN EMERGENCIES DUE TO UNFORESEEN CAUSES (INCLUDING BUT NOT LIMITED TO DELAYS IN TRANSPORTATION OR AN UNANTICIPATED INCREASE IN THE VOLUME OF WORK.)</p> <p>QUANTITIES: QUANTITIES LISTED IN THE REQUISITION ARE APPROXIMATIONS ONLY, BASED ON ESTIMATES SUPPLIED BY THE STATE SPENDING UNIT. IT IS UNDERSTOOD AND AGREED THAT THE CONTRACT SHALL COVER THE QUANTITIES ACTUALLY ORDERED FOR DELIVERY DURING THE TERM OF THE CONTRACT,</p>						

SEE REVERSE SIDE FOR TERMS AND CONDITIONS

SIGNATURE		TELEPHONE		DATE
TITLE	FEIN	ADDRESS CHANGES TO BE NOTED ABOVE		

WHEN RESPONDING TO RFQ, INSERT NAME AND ADDRESS IN SPACE ABOVE LABELED 'VENDOR'



State of West Virginia
 Department of Administration
 Purchasing Division
 2019 Washington Street East
 Post Office Box 50130
 Charleston, WV 25305-0130

Request for Quotation

RFQ NUMBER
708C0023

PAGE
3

ADDRESS CORRESPONDENCE TO ATTENTION OF
MICHAEL AUSTIN
304-558-2402

RFQ COPY

TYPE NAME/ADDRESS HERE

SHIP TO

DIVISION OF HIGHWAYS
 VARIOUS LOCALES AS INDICATED
 BY ORDER

DATE PRINTED 05/01/2008	TERMS OF SALE	SHIP VIA	F.O.B.	FREIGHT TERMS
-----------------------------------	---------------	----------	--------	---------------

BID OPENING DATE: **05/14/2008** BID OPENING TIME **01:30PM**

LINE	QUANTITY	UOP	CAT NO	ITEM NUMBER	UNIT PRICE	AMOUNT
------	----------	-----	--------	-------------	------------	--------

WHETHER MORE OR LESS THAN THE QUANTITIES SHOWN.

ORDERING PROCEDURE: SPENDING UNIT(S) SHALL ISSUE A WRITTEN STATE CONTRACT ORDER (FORM NUMBER WV-39) TO THE VENDOR FOR COMMODITIES COVERED BY THIS CONTRACT. THE ORIGINAL COPY OF THE WV-39 SHALL BE MAILED TO THE VENDOR AS AUTHORIZATION FOR SHIPMENT, A SECOND COPY MAILED TO THE PURCHASING DIVISION, AND A THIRD COPY RETAINED BY THE SPENDING UNIT.

BANKRUPTCY: IN THE EVENT THE VENDOR/CONTRACTOR FILES FOR BANKRUPTCY PROTECTION, THIS CONTRACT IS AUTOMATICALLY NULL AND VOID, AND IS TERMINATED WITHOUT FURTHER ORDER.

THE TERMS AND CONDITIONS CONTAINED IN THIS CONTRACT SHALL SUPERSEDE ANY AND ALL SUBSEQUENT TERMS AND CONDITIONS WHICH MAY APPEAR ON ANY ATTACHED PRINTED DOCUMENTS SUCH AS PRICE LISTS, ORDER FORMS, SALES AGREEMENTS OR MAINTENANCE AGREEMENTS, INCLUDING ANY ELECTRONIC MEDIUM SUCH AS CD-ROM.

REV. 04/11/2001

EXHIBIT 10

REQUISITION NO.:

ADDENDUM ACKNOWLEDGEMENT

I HEREBY ACKNOWLEDGE RECEIPT OF THE FOLLOWING CHECKED ADDENDUM(S) AND HAVE MADE THE NECESSARY REVISIONS TO MY PROPOSAL, PLANS AND/OR SPECIFICATION, ETC.

ADDENDUM NO.'S:

SIGNATURE		TELEPHONE	DATE
TITLE	FEIN	ADDRESS CHANGES TO BE NOTED ABOVE	

WHEN RESPONDING TO RFQ, INSERT NAME AND ADDRESS IN SPACE ABOVE LABELED 'VENDOR'



State of West Virginia
 Department of Administration
 Purchasing Division
 2019 Washington Street East
 Post Office Box 50130
 Charleston, WV 25305-0130

Request for Quotation

RFQ NUMBER
708C0023

PAGE
4

ADDRESS CORRESPONDENCE TO ATTENTION OF
**MICHAEL AUSTIN
 304-558-2402**

RFQ COPY

TYPE NAME/ADDRESS HERE

SHIP TO

**DIVISION OF HIGHWAYS
 VARIOUS LOCALES AS INDICATED
 BY ORDER**

DATE PRINTED 05/01/2008	TERMS OF SALE	SHIP VIA	F.O.B.	FREIGHT TERMS
-----------------------------------	---------------	----------	--------	---------------

BID OPENING DATE: **05/14/2008** BID OPENING TIME **01:30PM**

LINE	QUANTITY	UOP	CAT NO.	ITEM NUMBER	UNIT PRICE	AMOUNT
------	----------	-----	---------	-------------	------------	--------

- NO. 1
- NO. 2
- NO. 3
- NO. 4
- NO. 5

I UNDERSTAND THAT FAILURE TO CONFIRM THE RECEIPT OF TH
 ADDENDUM(S) MAY BE CAUSE FOR REJECTION OF BIDS.

VENDOR MUST CLEARLY UNDERSTAND THAT ANY VERBAL
 REPRESENTATION MADE OR ASSUMED TO BE MADE DURING ANY
 ORAL DISCUSSION HELD BETWEEN VENDOR'S REPRESENTATIVES
 AND ANY STATE PERSONNEL IS NOT BINDING. ONLY THE
 INFORMATION ISSUED IN WRITING AND ADDED TO THE
 SPECIFICATIONS BY AN OFFICIAL ADDENDUM IS BINDING.

[Signature]

 SIGNATURE

Electronic Communications of WV Inc
 COMPANY

May 14 2008
 DATE

REV. 11/96

VENDOR PREFERENCE CERTIFICATE

SEE REVERSE SIDE FOR TERMS AND CONDITIONS

SIGNATURE		TELEPHONE	DATE
TITLE	FEIN	ADDRESS CHANGES TO BE NOTED ABOVE	

WHEN RESPONDING TO RFQ, INSERT NAME AND ADDRESS IN SPACE ABOVE LABELED 'VENDOR'



State of West Virginia
 Department of Administration
 Purchasing Division
 2019 Washington Street East
 Post Office Box 50130
 Charleston, WV 25305-0130

Request for Quotation

RFQ NUMBER
708C0023

PAGE
5

ADDRESS CORRESPONDENCE TO ATTENTION OF
**MICHAEL AUSTIN
 304-558-2402**

RFQ COPY
 TYPE NAME/ADDRESS HERE

DIVISION OF HIGHWAYS
 VARIOUS LOCALES AS INDICATED
 BY ORDER

DATE PRINTED	TERMS OF SALE	SHIP VIA	FOB	FREIGHT TERMS
05/01/2008				

BID OPENING DATE: **05/14/2008** BID OPENING TIME **01:30PM**

LINE	QUANTITY	UOP	CAT NO	ITEM NUMBER	UNIT PRICE	AMOUNT
------	----------	-----	--------	-------------	------------	--------

CERTIFICATION AND APPLICATION* IS HEREBY MADE FOR PREFERENCE IN ACCORDANCE WITH WEST VIRGINIA CODE, 5A-3-37 (DOES NOT APPLY TO CONSTRUCTION CONTRACTS).

A. APPLICATION IS MADE FOR 2.5% PREFERENCE FOR THE REASON CHECKED:

() BIDDER IS AN INDIVIDUAL RESIDENT VENDOR AND HAS RESIDED CONTINUOUSLY IN WEST VIRGINIA FOR FOUR (4) YEARS IMMEDIATELY PRECEDING THE DATE OF THIS CERTIFICATION; OR

() BIDDER IS A PARTNERSHIP, ASSOCIATION OR CORPORATION RESIDENT VENDOR AND HAS MAINTAINED ITS HEAD-QUARTERS OR PRINCIPAL PLACE OF BUSINESS CONTINUOUSLY IN WEST VIRGINIA FOR FOUR (4) YEARS IMMEDIATELY PRECEDING THE DATE OF THIS CERTIFICATION; OR 80% OF THE OWNERSHIP INTEREST OF BIDDER IS HELD BY ANOTHER INDIVIDUAL, PARTNERSHIP, ASSOCIATION OR CORPORATION RESIDENT VENDOR WHO HAS MAINTAINED ITS HEADQUARTERS OR PRINCIPAL PLACE OF BUSINESS CONTINUOUSLY IN WEST VIRGINIA FOR FOUR (4) YEARS IMMEDIATELY PRECEDING THE DATE OF THIS CERTIFICATION; OR

() BIDDER IS A CORPORATION NONRESIDENT VENDOR WHICH HAS AN AFFILIATE OR SUBSIDIARY WHICH EMPLOYS A MINIMUM OF ONE HUNDRED STATE RESIDENTS AND WHICH HAS MAINTAINED ITS HEADQUARTERS OR PRINCIPAL PLACE OF BUSINESS WITHIN WEST VIRGINIA CONTINUOUSLY FOR THE FOUR (4) YEARS IMMEDIATELY PRECEDING THE DATE OF THIS CERTIFICATION.

B. APPLICATION IS MADE FOR 2.5% PREFERENCE FOR THE REASON CHECKED:

SEE REVERSE SIDE FOR TERMS AND CONDITIONS

SIGNATURE	TELEPHONE	DATE
TITLE	FEIN	ADDRESS CHANGES TO BE NOTED ABOVE

WHEN RESPONDING TO RFQ, INSERT NAME AND ADDRESS IN SPACE ABOVE LABELED "VENDOR"



State of West Virginia
 Department of Administration
 Purchasing Division
 2019 Washington Street East
 Post Office Box 50130
 Charleston, WV 25305-0130

Request for Quotation

RFQ NUMBER
708C0023

PAGE
6

ADDRESS CORRESPONDENCE TO ATTENTION OF
MICHAEL AUSTIN
304-558-2402

RFQ COPY
 TYPE NAME/ADDRESS HERE

DIVISION OF HIGHWAYS
 VARIOUS LOCALES AS INDICATED
 BY ORDER

PURCHASING

SHIP TO

DATE PRINTED	TERMS OF SALE	SHIP VIA	FOB	FREIGHT TERMS
05/01/2008				

BID OPENING DATE: **05/14/2008** BID OPENING TIME **01:30PM**

LINE	QUANTITY	UOP	CAT NO	ITEM NUMBER	UNIT PRICE	AMOUNT
<p>() BIDDER IS A RESIDENT VENDOR WHO CERTIFIES THAT, DURING THE LIFE OF THE CONTRACT, ON AVERAGE AT LEAST 75% OF THE EMPLOYEES WORKING ON THE PROJECT BEING BID ARE RESIDENTS OF WEST VIRGINIA WHO HAVE RESIDED IN THE STATE CONTINUOUSLY FOR THE TWO YEARS IMMEDIATELY PRECEDING SUBMISSION OF THIS BID;</p> <p>OR</p> <p>() BIDDER IS A NONRESIDENT VENDOR EMPLOYING A MINIMUM OF ONE HUNDRED STATE RESIDENTS OR IS A NONRESIDENT VENDOR WITH AN AFFILIATE OR SUBSIDIARY WHICH MAINTAINS ITS HEADQUARTERS OR PRINCIPAL PLACE OF BUSINESS WITHIN WEST VIRGINIA EMPLOYING A MINIMUM OF ONE HUNDRED STATE RESIDENTS WHO CERTIFIES THAT, DURING THE LIFE OF THE CONTRACT, ON AVERAGE AT LEAST 75% OF THE EMPLOYEES OR BIDDERS' AFFILIATE'S OR SUBSIDIARY'S EMPLOYEES ARE RESIDENTS OF WEST VIRGINIA WHO HAVE RESIDED IN THE STATE CONTINUOUSLY FOR THE TWO YEARS IMMEDIATELY PRECEDING SUBMISSION OF THIS BID.</p> <p>BIDDER UNDERSTANDS IF THE SECRETARY OF TAX & REVENUE DETERMINES THAT A BIDDER RECEIVING PREFERENCE HAS FAILED TO CONTINUE TO MEET THE REQUIREMENTS FOR SUCH PREFERENCE, THE SECRETARY MAY ORDER THE DIRECTOR OF PURCHASING TO: (A) RESCIND THE CONTRACT OR PURCHASE ORDER ISSUED; OR (B) ASSESS A PENALTY AGAINST SUCH BIDDER IN AN AMOUNT NOT TO EXCEED 5% OF THE BID AMOUNT AND THAT SUCH PENALTY WILL BE PAID TO THE CONTRACTING AGENCY OR DEDUCTED FROM ANY UNPAID BALANCE ON THE CONTRACT OR PURCHASE ORDER.</p> <p>BY SUBMISSION OF THIS CERTIFICATE, BIDDER AGREES TO DISCLOSE ANY REASONABLY REQUESTED INFORMATION TO THE PURCHASING DIVISION AND AUTHORIZES THE DEPARTMENT OF TAX AND REVENUE TO DISCLOSE TO THE DIRECTOR OF PURCHASING APPROPRIATE INFORMATION VERIFYING THAT BIDDER HAS PAID THE REQUIRED BUSINESS TAXES, PROVIDED</p>						

SEE REVERSE SIDE FOR TERMS AND CONDITIONS

SIGNATURE	TELEPHONE	DATE
TITLE	FEIN	ADDRESS CHANGES TO BE NOTED ABOVE

WHEN RESPONDING TO RFQ, INSERT NAME AND ADDRESS IN SPACE ABOVE LABELED 'VENDOR'



State of West Virginia
 Department of Administration
 Purchasing Division
 2019 Washington Street East
 Post Office Box 50130
 Charleston, WV 25305-0130

Request for Quotation

RFQ NUMBER
708C0023

PAGE
7

ADDRESS CORRESPONDENCE TO ATTENTION OF
**MICHAEL AUSTIN
 304-558-2402**

RFQ COPY
 TYPE NAME/ADDRESS HERE

DIVISION OF HIGHWAYS
 VARIOUS LOCALES AS INDICATED
 BY ORDER

DATE PRINTED	TERMS OF SALE	SHIP VIA	F.O.B.	FREIGHT TERMS
05/01/2008				

BID OPENING DATE: **05/14/2008** BID OPENING TIME **01:30PM**

LINE	QUANTITY	UOP	CAT NO	ITEM NUMBER	UNIT PRICE	AMOUNT
------	----------	-----	--------	-------------	------------	--------

THAT SUCH INFORMATION DOES NOT CONTAIN THE AMOUNTS OF TAXES PAID NOR ANY OTHER INFORMATION DEEMED BY THE TAX COMMISSIONER TO BE CONFIDENTIAL.

UNDER PENALTY OF LAW FOR FALSE SWEARING (WEST VIRGINIA CODE 61-5-3), BIDDER HEREBY CERTIFIES THAT THIS CERTIFICATE IS TRUE AND ACCURATE IN ALL RESPECTS; AND THAT IF A CONTRACT IS ISSUED TO BIDDER AND IF ANYTHING CONTAINED WITHIN THIS CERTIFICATE CHANGES DURING THE TERM OF THE CONTRACT, BIDDER WILL NOTIFY THE PURCHASING DIVISION IN WRITING IMMEDIATELY.

BIDDER: Electronic Communications of WV

DATE: May 14 2008

SIGNED: [Signature]

TITLE: PRESIDENT

* CHECK ANY COMBINATION OF PREFERENCE CONSIDERATION(S) IN EITHER "A" OR "B", OR BOTH "A" AND "B" WHICH YOU ARE ENTITLED TO RECEIVE. YOU MAY REQUEST UP TO THE MAXIMUM 5% PREFERENCE FOR BOTH "A" AND "B". (REV. 12/00)

NOTICE

A SIGNED BID MUST BE SUBMITTED TO:

DEPARTMENT OF ADMINISTRATION
 PURCHASING DIVISION

SEE REVERSE SIDE FOR TERMS AND CONDITIONS

SIGNATURE	TELEPHONE	DATE
TITLE	FEIN	ADDRESS CHANGES TO BE NOTED ABOVE

WHEN RESPONDING TO RFQ, INSERT NAME AND ADDRESS IN SPACE ABOVE LABELED 'VENDOR'



State of West Virginia
 Department of Administration
 Purchasing Division
 2019 Washington Street East
 Post Office Box 50130
 Charleston, WV 25305-0130

Request for Quotation

BFO NUMBER
708C0023

PAGE
8

ADDRESS CORRESPONDENCE TO ATTENTION OF
**MICHAEL AUSTIN
 304-558-2402**

RFQ COPY

TYPE NAME/ADDRESS HERE

SHIP TO

DIVISION OF HIGHWAYS
 VARIOUS LOCALES AS INDICATED
 BY ORDER

DATE PRINTED	TERMS OF SALE	SHIP VIA	FOB	FREIGHT TERMS
05/01/2008				

BID OPENING DATE: **05/14/2008** BID OPENING TIME **01:30PM**

LINE	QUANTITY	UOP	CAT NO	ITEM NUMBER	UNIT PRICE	AMOUNT
<p>BUILDING 15 2019 WASHINGTON STREET, EAST CHARLESTON, WV 25305-0130</p> <p>THE BID SHOULD CONTAIN THIS INFORMATION ON THE FACE OF THE ENVELOPE OR THE BID MAY NOT BE CONSIDERED:</p> <p>SEALED BID</p> <p>BUYER: 33</p> <p>RFQ. NO.: 708C0023</p> <p>BID OPENING DATE: 05/14/2008</p> <p>BID OPENING TIME: 1:30 PM</p> <p>PLEASE PROVIDE A FAX NUMBER IN CASE IT IS NECESSARY TO CONTACT YOU REGARDING YOUR BID: ----- 304-776-7092</p> <p>CONTACT PERSON (PLEASE PRINT CLEARLY): ----- Tim Ford</p>						

SEE REVERSE SIDE FOR TERMS AND CONDITIONS

SIGNATURE	TELEPHONE	DATE
TITLE	FEIN	ADDRESS CHANGES TO BE NOTED ABOVE

WHEN RESPONDING TO RFQ, INSERT NAME AND ADDRESS IN SPACE ABOVE LABELED 'VENDOR'



State of West Virginia
 Department of Administration
 Purchasing Division
 2019 Washington Street East
 Post Office Box 50130
 Charleston, WV 25305-0130

Request for Quotation

RFQ NUMBER
708C0023

PAGE
9

ADDRESS CORRESPONDENCE TO ATTENTION OF
MICHAEL AUSTIN
304-558-2402

RFQ COPY

TYPE NAME/ADDRESS HERE

SHIP TO

DIVISION OF HIGHWAYS
 VARIOUS LOCALES AS INDICATED
 BY ORDER

DATE PRINTED	TERMS OF SALE	SHIP VIA	FOB	FREIGHT TERMS
05/01/2008				

BID OPENING DATE: **05/14/2008** BID OPENING TIME **01:30PM**

LINE	QUANTITY	UOP	CAT NO	ITEM NUMBER	UNIT PRICE	AMOUNT
***** THIS IS THE END OF RFQ 708C0023 ***** TOTAL:						<u>171.00</u>

SEE REVERSE SIDE FOR TERMS AND CONDITIONS

SIGNATURE _____ TELEPHONE _____ DATE _____

TITLE _____ FEIN _____ ADDRESS CHANGES TO BE NOTED ABOVE

WHEN RESPONDING TO RFQ, INSERT NAME AND ADDRESS IN SPACE ABOVE LABELED 'VENDOR'

708C0023

LED BEACON CLASS 1

Voltage 12V/24V

AMPS 1.5 MAX @ 12.8V

Led light source high intensity white with 360° visibility
 Must have selectable flash patterns
 Must have high/low intensity circuit
 Overall height not to exceed 6"

Mounting Base shall be polycarbonate with flange not to exceed 7" with 3 bolt mounting spaced at 120° as well as a female 1" NPT pipe fitting

Circuit Board and Electronics shall be coated with a silicone material or equal to Provide moisture and corrosion resistance.

Optic Dome shall be Amber, made of polycarbonate meeting Standard 1079 or better.

Must meet SAE J845 May 1997, Class 1 in Amber and shall be

Whelen L21 12V or Equal \$ 171.00 ea. Ameca Certified *Pem Mount*

Whelen L21 12V or Equal \$ 171.00 ea. Ameca Certified *Pipe Mount*

Warranty may be a factor in bid evaluation
 Sample of bid unit may be required before award of Contract.

708C0023

ORDERING INFORMATION: Parts orders against this contract may be placed by the WVDOH Equipment Division and the Ten (10) WVDOH District locations as listed (attached). These parts orders may be placed by telephone and/or facsimile.

METHOD OF PAYMENT: The Purchasing card (Visa) is the preferred method of payment. Vendor must supply a credit receipt, sales receipt, or cash register receipt. Vendor shall not charge until parts are shipped.

PURCHASING CARD ACCEPTANCE: The State of West Virginia currently utilizes a VISA Purchasing card program which is issued through a local bank. The successful vendor must accept the State of West Virginia VISA purchasing card for payment of all orders placed by any state agency.

REV. 07/16/2007

Equipment Division

WV Division of Highways
PO Box 610
Buckhannon, WV 26201
ATTENTION: Kevin Riley (FOUR COPYS)

WV DOT/Division of Highways
D-1
1340 Smith St.
Charleston, WV 25301
Attn: Melissa Mullens

WV DOT/Division of Highways
D-2
Po. Box 880
Huntington, WV 25712
Attn: Keith Chapman

WV DOT/Division of Highways
D-3
626 Depot St.
Parkersburg, WV 26101
Attn: Mark Kimes

WV DOT/Division of Highways
D-4
P.O. BOX 2570
Clarksburg, WV 26301
Attn: John Bartlett

WV DOT/Division of Highways
D-5
PO BOX 99
BURLINGTON, WV 26710
Attn: Pat Broadhurst

WV DOT/Division of Highways
D-6
1 DOT Drive.
Moundsville, WV 26041-2353
Attn: Carol Ryan

WV DOT/Division Highways
D-7
Drawer 1228
Weston, WV 26452
Attn: Melissa Jordan

WV DOT/Division of Highways
D-8
PO Box 1516
Elkins, WV 26241
Attn: Debbie Barnett

WV DOT/Division of Highways
D-9
103 1/2 Church Street
Lewisburg, WV 24901
Attn: Keith Brown

WV DOT/Division of Highways
D-10
270 Hardwood Lane
Princeton, WV 24740
Attn: Tommy Camden

STATE OF WEST VIRGINIA
Purchasing Division

PURCHASING AFFIDAVIT

West Virginia Code §5A-3-10a states: No contract or renewal of any contract may be awarded by the state or any of its political subdivisions to any vendor or prospective vendor when the vendor or prospective vendor or a related party to the vendor or prospective vendor is a debtor and the debt owed is an amount greater than one thousand dollars in the aggregate

DEFINITIONS:

"Debt" means any assessment, premium, penalty, fine, tax or other amount of money owed to the state or any of its political subdivisions because of a judgment, fine, permit violation, license assessment, defaulted workers' compensation premium, penalty or other assessment presently delinquent or due and required to be paid to the state or any of its political subdivisions, including any interest or additional penalties accrued thereon.

"Debtor" means any individual, corporation, partnership, association, limited liability company or any other form or business association owing a debt to the state or any of its political subdivisions. "Political subdivision" means any county commission; municipality; county board of education; any instrumentality established by a county or municipality; any separate corporation or instrumentality established by one or more counties or municipalities, as permitted by law; or any public body charged by law with the performance of a government function or whose jurisdiction is coextensive with one or more counties or municipalities. "Related party" means a party, whether an individual, corporation, partnership, association, limited liability company or any other form or business association or other entity whatsoever, related to any vendor by blood, marriage, ownership or contract through which the party has a relationship of ownership or other interest with the vendor so that the party will actually or by effect receive or control a portion of the benefit, profit or other consideration from performance of a vendor contract with the party receiving an amount that meets or exceeds five percent of the total contract amount.

EXCEPTION: The prohibition of this section does not apply where a vendor has contested any tax administered pursuant to chapter eleven of this code, workers' compensation premium, permit fee or environmental fee or assessment and the matter has not become final or where the vendor has entered into a payment plan or agreement and the vendor is not in default of any of the provisions of such plan or agreement.

LICENSING: Vendors must be licensed and in good standing in accordance with any and all state and local laws and requirements by any state or local agency of West Virginia, including, but not limited to, the West Virginia Secretary of State's Office, the West Virginia Tax Department, West Virginia Insurance Commission, or any other state agencies or political subdivision. Furthermore, the vendor must provide all necessary releases to obtain information to enable the Director or spending unit to verify that the vendor is licensed and in good standing with the above entities.

CONFIDENTIALITY: The vendor agrees that he or she will not disclose to anyone, directly or indirectly, any such personally identifiable information or other confidential information gained from the agency, unless the individual who is the subject of the information consents to the disclosure in writing or the disclosure is made pursuant to the agency's policies, procedures and rules. Vendors should visit www.state.wv.us/admin/purchase/privacy for the Notice of Agency Confidentiality Policies.

Under penalty of law for false swearing (West Virginia Code, §61-5-3), it is hereby certified that the vendor acknowledges the information in this said affidavit and are in compliance with the requirements as stated.

Vendor's Name: Electronic Communications of WV Inc

Authorized Signature:  Date: May 14 2008

L21 and L22 Series

360° SUPER BRIGHT UNIFORM INTENSITY SUPER-LED® BEACONS

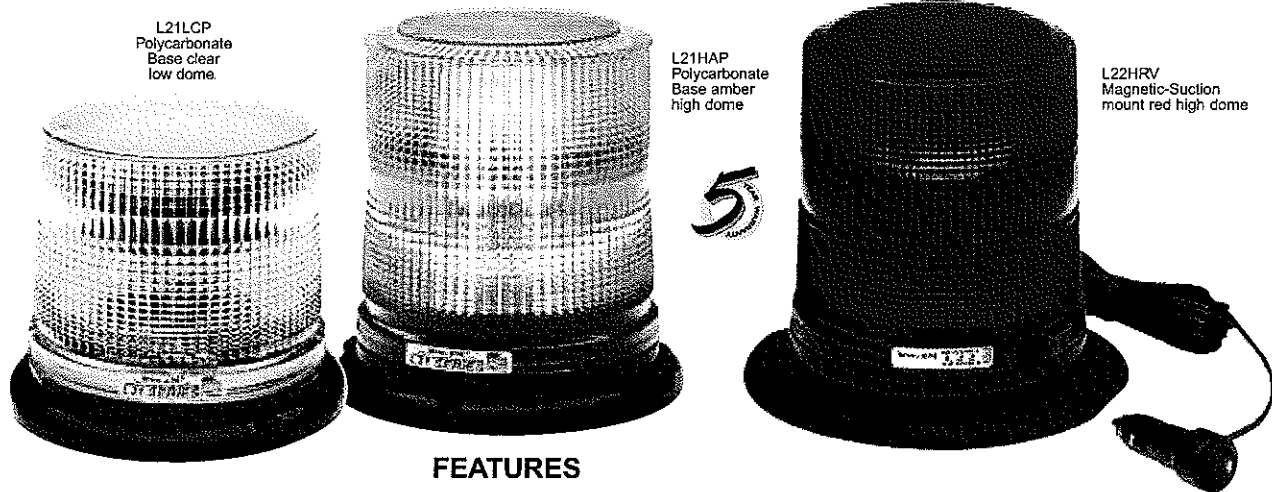

The L21 and L22 Series Beacons are certified SAE Class I (L21) and Class II (L22). Both models have a rated life that exceeds comparable flash tubes by more than 50:1.

The L21 utilizes new Broadband Energy Radiator™ Technology (patent pending). This solid-state beacon resembles traditional strobe beacons but has greater light output and lower amp draw.

The L22 features generation 3.5 LED technology that rivals strobe in power with lower amp draw.



L22 beacon permanent mount installed on vehicle roof

FEATURES

Both L21 and L22

- ❑ Combination mounting: pipe, permanent and J-hook.
- ❑ Select 12 or 24 VDC.
- ❑ 100,000 hour rated life.
- ❑ SmartLED™ beacon design.
- ❑ Permanent/pipe mount supplied with 6" pigtail. Magnetic mount supplied with 10' straight cord with LED "ON" indicator switch and cigar plug.
- ❑ Five-year warranty.

L21 Only

- ❑ Certified SAE J845 Class, Class I 360° (amber).
- ❑ Low current draw: 1.5 amp (peak), 0.6 amp (average) @12.8 VDC.
- ❑ 75 SignalAlert™ flashes per minute standard. Permanent mount features 24 total Scan-Lock™ alternating and simultaneous flash patterns (synchronize with up to 8 total beacons).
- ❑ Choice of high or low polycarbonate dome.
- ❑ Polycarbonate or cast aluminum base.
- ❑ Virtually no EMI radiation.
- ❑ Hi/Low mode available in permanent mount only.
- ❑ Permanent mount available with cruise light with four intensity levels.

L22 Only

- ❑ Certified SAE J845 Class, Class II 360° (amber).
- ❑ Low current draw: 0.65 amp (peak), 0.26 amp (average) @12.8 VDC.
- ❑ 75 SignalAlert™ flashes per minute standard; 15 total Scan-Lock™ flash patterns built-in.
- ❑ Heavy-duty magnet enhanced suction mount.
- ❑ Polycarbonate base and dome (available high dome only).

Note: Magnetic or magnetic-suction mount models do not offer Scan-Lock™ cruise light low power or SYNC functions.

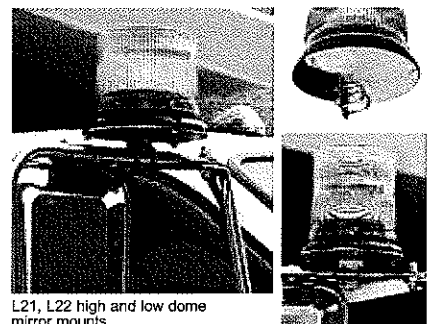

L21, L22 high and low dome mirror mounts

- ❑ L21 available in Amber and White only
- ❑ L22 in Red, Amber, White and Blue

Form# L21221107



Officially Licensed
Warning Lights Of
NASCAR®



All Whelen Products
are proudly made
in the U.S.A.*

WHELEN®

ENGINEERING COMPANY, INC.

Engineers for the Emergency Warning Industry

L21 and L22 Series

360° SUPER BRIGHT UNIFORM INTENSITY SUPER-LED® BEACONS

L21LCP
Polycarbonate
Base clear
low dome

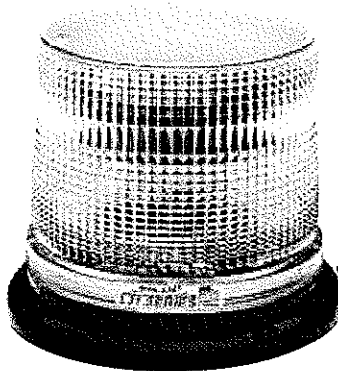

L21HAP
Polycarbonate
Base amber
high dome

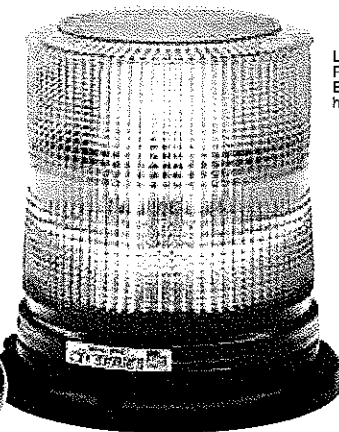

L22HRV
Magnetic-Suction
mount red high dome

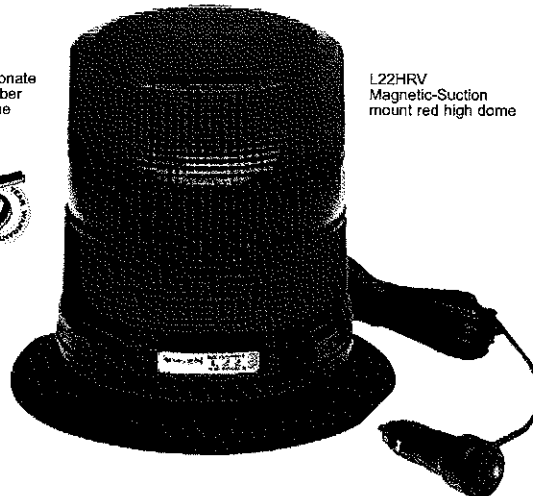

The L21 and L22 Series Beacons are certified SAE Class I (L21) and Class II (L22). Both models have a rated life that exceeds comparable flash tubes by more than 50:1.

The L21 utilizes new Broadband Energy Radiator™ Technology (patent pending). This solid-state beacon resembles traditional strobe beacons but has greater light output and lower amp draw.

The L22 features generation 3.5 LED technology that rivals strobe in power with lower amp draw.



L22 beacon permanent mount installed on vehicle roof

FEATURES

Both L21 and L22

- ❑ Combination mounting: pipe, permanent and J-hook.
- ❑ Select 12 or 24 VDC.
- ❑ 100,000 hour rated life.
- ❑ SmartLED™ beacon design.
- ❑ Permanent/pipe mount supplied with 6" pigtail. Magnetic mount supplied with 10' straight cord with LED "ON" indicator switch and cigar plug.
- ❑ Five-year warranty.

L21 Only

- ❑ Certified SAE J845 Class, Class I 360° (amber).
- ❑ Low current draw: 1.5 amp (peak), 0.6 amp (average) @12.8 VDC.
- ❑ 75 SignalAlert™ flashes per minute standard. Permanent mount features 24 total Scan-Lock™ alternating and simultaneous flash patterns (synchronize with up to 8 total beacons).
- ❑ Choice of high or low polycarbonate dome.
- ❑ Polycarbonate or cast aluminum base.
- ❑ Virtually no EMI radiation.
- ❑ Hi/Low mode available in permanent mount only.
- ❑ Permanent mount available with cruise light with four intensity levels

L22 Only

- ❑ Certified SAE J845 Class, Class II 360° (amber).
- ❑ Low current draw: 0.65 amp (peak), 0.26 amp (average) @12.8 VDC.
- ❑ 75 SignalAlert™ flashes per minute standard; 15 total Scan-Lock™ flash patterns built-in.
- ❑ Heavy-duty magnet enhanced suction mount
- ❑ Polycarbonate base and dome (available high dome only).

Note: Magnetic or magnetic-suction mount models do not offer Scan-Lock™ cruise light low power or SYNC functions

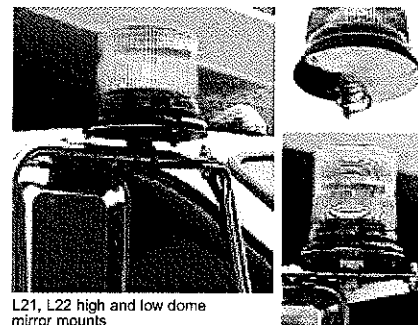

L21, L22 high and low dome mirror mounts

L21 available in Amber and White only

L22 in Red, Amber, White and Blue

Form# L21221107



Officially Licensed
Warning Lights Of
NASCAR®



All Whelen Products
are proudly made
in the U S A *

WHELEN®

ENGINEERING COMPANY, INC.

Engineers for the Emergency Warning Industry

L21 Beacon Models

- L21H*P:** 12 VDC, combination mount, polycarbonate base, high dome
- L21H*M:** 12 VDC, magnetic mount with 10' cigar cord with LED "ON" indicator switch, polycarbonate base, high dome
- L21H*V:** 12 VDC, magnetic-suction mount with 10' cigar cord with LED "ON" indicator switch, polycarbonate base, high dome
- L21H*P4:** 24 VDC, combination mount, polycarbonate base, high dome
- L21H*M4:** 24 VDC, magnetic mount with 10' cigar cord and LED "ON" indicator switch, polycarbonate base, high dome
- L21L*P:** 12 VDC, combination mount, polycarbonate base, low dome
- L21L*M:** 12 VDC, magnetic mount with 10' cigar cord and LED "ON" indicator switch, polycarbonate base, low dome
- L21L*V:** 12 VDC, magnetic-suction mount with 10' cigar cord with LED "ON" indicator switch, polycarbonate base, low dome
- L21L*P4:** 24 VDC, combination mount, polycarbonate base, low dome
- L21L*M4:** 24 VDC, magnetic mount, 10' cigar cord with LED "ON" indicator switch, polycarbonate base, low dome
- L21H*C:** 12 VDC, combination mount, cast aluminum base, high dome
- L21H*C4:** 24 VDC, combination mount, cast aluminum base, high dome
- L21L*C:** 12 VDC, combination mount, cast aluminum base, low dome
- L21L*C4:** 24 VDC, combination mount, cast aluminum base, low dome

REPLACEMENT PARTS

DH2000*: High Dome

DL2000*: Low Dome

Replace (*) in above model numbers with letter indicating color choice: A = Amber C = Clear

L22 Lighthead Models (high dome only)

- L22H*P:** 12 VDC, combination mount, polycarbonate base
- L22H*M:** 12 VDC, magnetic mount, polycarbonate base with 10' cigar cord and built-in LED "ON" indicator switch
- L22H*V:** 12 VDC, magnetic-suction mount, polycarbonate base with 10' cigar cord and built-in LED "ON" indicator switch
- L22H*P4:** 24 VDC, combination mount, polycarbonate base
- L22H*M4:** 24 VDC, magnetic mount, polycarbonate base with 10' cigar cord and built-in LED "ON" indicator switch

Replace (*) in above model numbers with letter indicating color choice:

A = Amber LED and amber dome B = Blue LED and blue dome C = White LED and clear dome
R = Red LED and red dome 1 = Amber LED and clear dome 2 = Blue LED and clear dome
5 = Red LED and clear dome

REPLACEMENT PART

DH2000*: Dome

Replace (*) in above model number with letter indicating color choice: A = Amber B = Blue
C = Clear R = Red

NOTE: The use of any magnetic or magnetic-suction mounted warning beacon on the vehicle while in motion is at the discretion and risk of the user

L21 & 22 Options

- MMK:** Magnetic Kit with 8" cord and plug
- CP:** 8" cord and plug
- SS:** Sun shade, mylar
- BGL:** Branch guard, low dome, 6-1/2" tall with beacon
- BGH:** Branch guard, high dome, 7-1/2" tall with beacon
- LSK:** Lighted switch kit mounted on bracket, wired and fused
- MIRROR20:** Mirror mount brackets

L21 and 22 Specifications and Dimensions

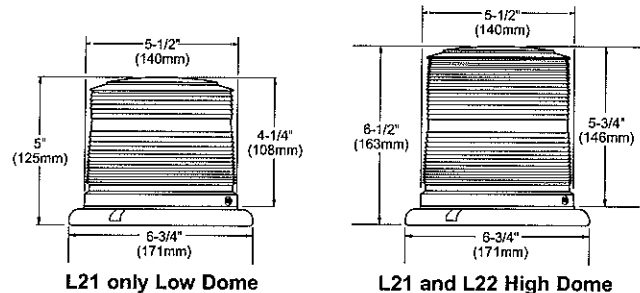

Mounting

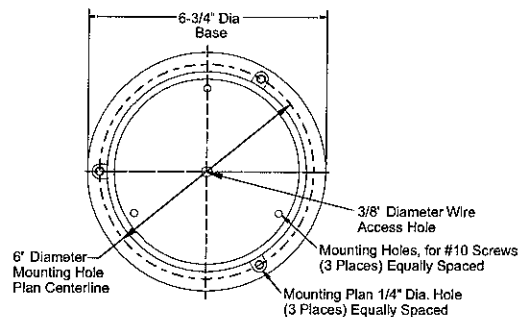

Magnetic mount models do not include Scan-Lock™, cruise light, low power or sync feature

Available Scan-Lock™ Flash Patterns

Scan-Lock™ allows you to choose between available flash patterns

L21 (24 patterns)

- ☒ SignalAlert™ 75 (Phase 1)
- ☒ SignalAlert™ 75 (Phase 2)
- ☒ CometFlash™ 75 (Phase 1)
- ☒ CometFlash™ 75 (Phase 2)
- ☒ DoubleFlash 75 (Phase 1)
- ☒ DoubleFlash 75 (Phase 2)
- ☒ SingleFlash 75 (Phase 1)
- ☒ SingleFlash 75 (Phase 2)
- ☒ ComAlert™ 75 (Phase 1)
- ☒ ComAlert™ 75 (Phase 2)
- ☒ LongBurst™ 75 (Phase 1)
- ☒ LongBurst™ 75 (Phase 2)
- ☒ Ping-Pong 75 (Phase 1)
- ☒ Ping-Pong 75 (Phase 2)
- ☒ SingleFlash 60
- ☒ SingleFlash 90
- ☒ SingleFlash 120
- ☒ SingleFlash 300
- ☒ DoubleFlash 150
- ☒ ComAlert™ 150
- ☒ ActionFlash™ 1
- ☒ ActionFlash™ 2
- ☒ ModuFlash™
- ☒ ActionScan™

L22 (15 patterns)

- ☒ SignalAlert™ 75
- ☒ SignalAlert™ 150
- ☒ SingleFlash 375
- ☒ DoubleFlash 150
- ☒ SingleFlash 75
- ☒ DoubleFlash 75
- ☒ CometFlash™ 75
- ☒ ActionFlash™
- ☒ DoubleFlash 75
- ☒ ComAlert™ 70
- ☒ ComAlert™
- ☒ ActionScan™
- ☒ SignalAlert™ Steady
- ☒ Steady-Brake
- ☒ Steady

WHELEN
ENGINEERING COMPANY, INC.

Route 145, Winthrop Road
Chester, Connecticut 06412-0684
(860) 526-9504 • Fax: (860) 526-4078
www.whelen.com



Whelen Engineering reserves the right to upgrade and improve products without notice

*Some back-up alarms are made in Canada for Whelen.
NASCAR® is a registered trademark of the National Association for Stock Car Auto Racing, Inc.
© 2007 Whelen Engineering Co. Inc. Printed in U.S.A. Code No. 11700G-112707

L21 Series

SUPER-LED® 360° BEACONS

Utilizing new Broadband Energy Radiator™ Technology (patent pending)

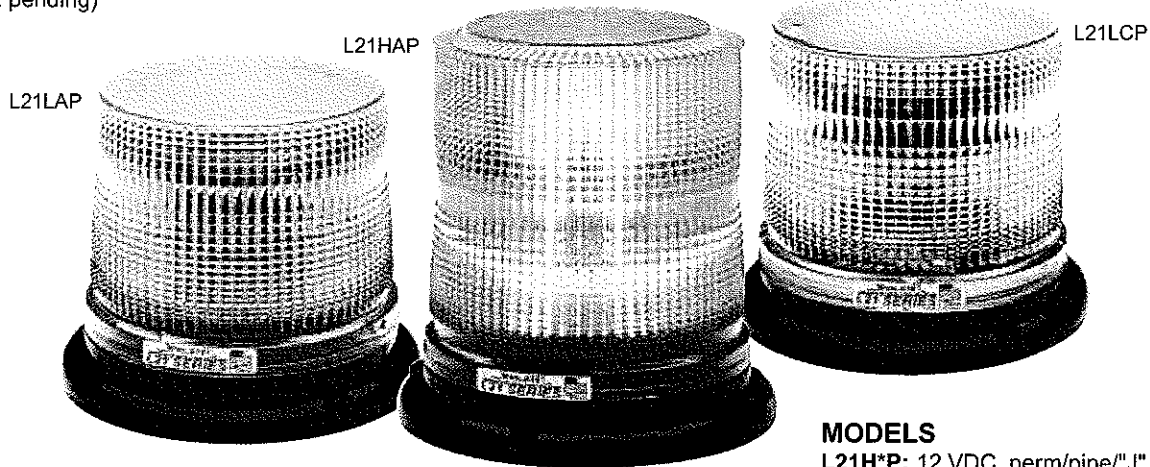

L21 Series Beacons are certified SAE Class 1. Utilizing new Broadband Energy Radiator™ Technology (patent pending), these solid-state beacons resemble traditional strobe beacons but with greater light output and lower amp draw. Best of all, the Super-LED light source has a rated life that exceeds that of comparable flash tubes by more than 50:1.

FEATURES

- Certified SAE Class J845 Class 1 360° (amber).
- 50,000 hour rated life.
- Low current draw: 1.5 Amp (peak), 0.6 Amp (average) @12.8 VDC.
- Combination mounting (pipe/permanent/J-hook) allows universal application.
- SmartLED® beacon design offers 75 SignalAlert™ flashes per minute standard. Permanent mount, features 21 total Scan-Lock™ alternating and simultaneous flash patterns built-in (synchronize with up to 8 total beacons).
- Supplied with 6" pigtail (combination mount) or 10' straight cord with LED indicator switch and cigar plug (magnetic mount only).
- Choice of high or low polycarbonate dome.
- Polycarbonate or cast aluminum base.
- Virtually no EMI radiation
- Cruise light with 4 intensity levels (permanent mount only).
- Hi/Low mode (permanent mount only).
- Select 12 or 24 VDC.
- Five-year warranty.

Note: Magnetic mount models do not offer Scan-Lock cruise light, low power or SYNC functions.

Note: The use of any magnetic mounted warning beacon on the vehicle while in motion is at the discretion and risk of the user

MODELS

- L21H*P:** 12 VDC, perm/pipe/"J" hook mount, high dome
- L21H*M:** 12 VDC, magnetic mount with 10' cord with LED indicator switch, high dome
- L21H*V:** 12 VDC, magnetic-suction mount with 10' cord with LED indicator switch, high dome
- L21H*P4:** 24 VDC, perm/pipe/"J" hook mount, high dome
- L21H*M4:** 24 VDC, magnetic mount with 10' cord with LED indicator switch, high dome
- L21L*P:** 12 VDC, perm/pipe/"J" hook mount, low dome
- L21L*M:** 12 VDC, magnetic mount with 10' cord with LED indicator switch, low dome
- L21L*V:** 12 VDC, magnetic-suction mount with 10' cord with LED indicator switch, low dome
- L21L*P4:** 24 VDC, perm/pipe/"J" hook mount, low dome
- L21L*M4:** 24 VDC, magnetic mount with 10' cord with LED indicator switch, low dome
- L21H*C:** 12 VDC, perm/pipe/"J" hook mount, cast aluminum base, high dome
- L21H*C4:** 24 VDC, perm/pipe/"J" hook mount, cast aluminum base, high dome
- L21L*C:** 12 VDC, perm/pipe/"J" hook mount, cast aluminum base, low dome
- L21L*C4:** 24 VDC, perm/pipe/"J" hook mount, cast aluminum base, low dome

REPLACEMENT PARTS

DH2000*: High Dome

DL2000*: Low Dome

Replace asterisk (*) in above model numbers with letter indicating color choice: A = Amber C = Clear

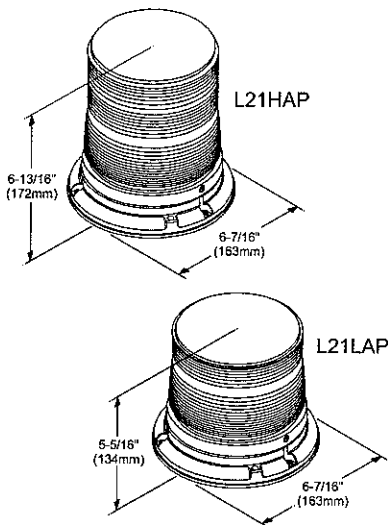

Shown: Permanent Mount Beacon

Domes available in amber or clear safety colors only.

Form# L210807

© 2007 Whelen Engineering Co., Inc. Printed in U.S.A.
Whelen Engineering reserves the right to upgrade and improve products without notice.
** Some back-up alarms are custom made for Whelen in Canada.
NASCAR is a registered trademark of the National Association for Stock Car Auto Racing, Inc.
Code No. 10269A-0807



All Whelen Products are proudly made in the U.S.A. **

WHELEN®

ENGINEERING COMPANY, INC.

Route 145, Winthrop Road
Chester, Connecticut 06412-0684
(860) 526-9504 • Fax: (860) 526-4078
www.whelen.com

Engineers for the Emergency Warning Industry