



State of West Virginia  
 Department of Administration  
 Purchasing Division  
 2019 Washington Street East  
 Post Office Box 50130  
 Charleston, WV 25305-0130

# Request for Quotation

RFQ NUMBER  
**708C0006**

PAGE  
**1**

ADDRESS CORRESPONDENCE TO ATTENTION OF  
**MICHAEL AUSTIN**  
**304-558-2402**

PURCHASER

\*709051756      304-346-5301  
**WV TRACTOR COMPANY**  
**PO BOX 473**  
  
**CHARLESTON WV 25322**

SHIP TO

**DIVISION OF HIGHWAYS**  
**VARIOUS LOCALES AS INDICATED**  
**BY ORDER**

DATE PRINTED <b>11/19/2007</b>	TERMS OF SALE <b>Net 30</b>	SHIP VIA <b>Truck</b>	F.O.B. <b>Buckhannon</b>	FREIGHT TERMS <b>Prepaid</b>
BID OPENING DATE: <b>12/05/2007</b>		BID OPENING TIME <b>01:30PM</b>		

LINE	QUANTITY	UOP	CAT NO	ITEM NUMBER	UNIT PRICE	AMOUNT
0001	1	EA		060-74		
<p>TEREX MODEL TX760B LOADER, BACKHOE BOOM SWIVEL PARTS            POWERTILT PT-7</p> <p>CONTRACT TO PROVIDE TEREX MODEL TX60B LOADER, BACKHOE            BOOM SWIVEL PARTS OR EQUAL WHICH MAY BE REQUIRED BY            THE WV DIVISION OF HIGHWAYS PER THE ATTACHED.</p> <p>THE MODEL/BRAND/SPECIFICATIONS NAMED HEREIN ESTABLISH            THE ACCEPTABLE LEVEL OF QUALITY ONLY AND ARE NOT            INTENDED TO REFLECT A PREFERENCE OR FAVOR ANY            PARTICULAR BRAND OR VENDOR. VENDORS WHO ARE BIDDING            ALTERNATES SHOULD SO STATE AND INCLUDE PERTINENT            LITERATURE AND SPECIFICATIONS. FAILURE TO PROVIDE            INFORMATION FOR ANY ALTERNATES MAY BE GROUNDS FOR            REJECTION OF THE BID. THE STATE RESERVES THE RIGHT            TO WAIVE MINOR IRREGULARITIES IN BIDS OR SPECIFICATIONS            IN ACCORDANCE WITH SECTION 148-1-4(F) OF THE WEST            VIRGINIA LEGISLATIVE RULES AND REGULATIONS.</p> <p>EXHIBIT 3</p> <p>LIFE OF CONTRACT: THIS CONTRACT BECOMES EFFECTIVE ON            ..... AND EXTENDS FOR A PERIOD OF ONE (1)            YEAR OR UNTIL SUCH "REASONABLE TIME" THEREAFTER AS IS            NECESSARY TO OBTAIN A NEW CONTRACT OR RENEW THE            ORIGINAL CONTRACT. THE "REASONABLE TIME" PERIOD SHALL            NOT EXCEED TWELVE (12) MONTHS. DURING THIS "REASONABLE            TIME" THE VENDOR MAY TERMINATE THIS CONTRACT FOR ANY            REASON UPON GIVING THE DIRECTOR OF PURCHASING 30 DAYS            WRITTEN NOTICE.</p>						

SEE REVERSE SIDE FOR TERMS AND CONDITIONS

SIGNATURE <i>Wayne Tracy</i>	TELEPHONE 346-5301	DATE 12-4-07
TITLE Pres.	FEIN 550621655	ADDRESS CHANGES TO BE NOTED ABOVE

WHEN RESPONDING TO RFQ, INSERT NAME AND ADDRESS IN SPACE ABOVE LABELED 'VENDOR'



State of West Virginia  
 Department of Administration  
 Purchasing Division  
 2019 Washington Street East  
 Post Office Box 50130  
 Charleston, WV 25305-0130

# Request for Quotation

RFQ NUMBER
708C0006

PAGE
2

ADDRESS CORRESPONDENCE TO ATTENTION OF:
MICHAEL AUSTIN 304-558-2402

VENDOR	*709051756	304-346-5301
	WV TRACTOR COMPANY	
	PO BOX 473	
	CHARLESTON WV 25322	

SHIP TO	DIVISION OF HIGHWAYS
	VARIOUS LOCALES AS INDICATED BY ORDER

DATE PRINTED	TERMS OF SALE	SHIP VIA	F.O.B.	FREIGHT TERMS
11/19/2007				

BID OPENING DATE: 12/05/2007 BID OPENING TIME 01:30PM

LINE	QUANTITY	UOP	CAT NO.	ITEM NUMBER	UNIT PRICE	AMOUNT
<p>UNLESS SPECIFIC PROVISIONS ARE STIPULATED ELSEWHERE IN THIS CONTRACT DOCUMENT, THE TERMS, CONDITIONS AND PRICING SET HEREIN ARE FIRM FOR THE LIFE OF THE CONTRACT.</p> <p>RENEWAL: THIS CONTRACT MAY BE RENEWED UPON THE MUTUAL WRITTEN CONSENT OF THE SPENDING UNIT AND VENDOR, SUBMITTED TO THE DIRECTOR OF PURCHASING THIRTY (30) DAYS PRIOR TO THE EXPIRATION DATE. SUCH RENEWAL SHALL BE IN ACCORDANCE WITH THE TERMS AND CONDITIONS OF THE ORIGINAL CONTRACT AND SHALL BE LIMITED TO TWO (2) ONE (1) YEAR PERIODS.</p> <p>CANCELLATION: THE DIRECTOR OF PURCHASING RESERVES THE RIGHT TO CANCEL THIS CONTRACT IMMEDIATELY UPON WRITTEN NOTICE TO THE VENDOR IF THE COMMODITIES AND/OR SERVICES SUPPLIED ARE OF AN INFERIOR QUALITY OR DO NOT CONFORM TO THE SPECIFICATIONS OF THE BID AND CONTRACT HEREIN.</p> <p>OPEN MARKET CLAUSE: THE DIRECTOR OF PURCHASING MAY AUTHORIZE A SPENDING UNIT TO PURCHASE ON THE OPEN MARKET, WITHOUT THE FILING OF A REQUISITION OR COST ESTIMATE, ITEMS SPECIFIED ON THIS CONTRACT FOR IMMEDIATE DELIVERY IN EMERGENCIES DUE TO UNFORESEEN CAUSES (INCLUDING BUT NOT LIMITED TO DELAYS IN TRANSPORTATION OR AN UNANTICIPATED INCREASE IN THE VOLUME OF WORK.)</p> <p>QUANTITIES: QUANTITIES LISTED IN THE REQUISITION ARE APPROXIMATIONS ONLY, BASED ON ESTIMATES SUPPLIED BY THE STATE SPENDING UNIT. IT IS UNDERSTOOD AND AGREED THAT THE CONTRACT SHALL COVER THE QUANTITIES ACTUALLY ORDERED FOR DELIVERY DURING THE TERM OF THE CONTRACT, WHETHER MORE OR LESS THAN THE QUANTITIES SHOWN.</p> <p>ORDERING PROCEDURE: SPENDING UNIT(S) SHALL ISSUE A</p>						

SEE REVERSE SIDE FOR TERMS AND CONDITIONS

SIGNATURE	TELEPHONE	DATE
TITLE	FEIN	ADDRESS CHANGES TO BE NOTED ABOVE

WHEN RESPONDING TO RFQ, INSERT NAME AND ADDRESS IN SPACE ABOVE LABELED 'VENDOR'



State of West Virginia  
 Department of Administration  
 Purchasing Division  
 2019 Washington Street East  
 Post Office Box 50130  
 Charleston, WV 25305-0130

# Request for Quotation

RFQ NUMBER  
**708C0006**

PAGE  
**3**

ADDRESS CORRESPONDENCE TO ATTENTION OF  
**MICHAEL AUSTIN**  
**304-558-2402**

VENDOR

\*709051756      304-346-5301  
**WV TRACTOR COMPANY**  
**PO BOX 473**  
  
**CHARLESTON WV 25322**

SHIP TO

**DIVISION OF HIGHWAYS**  
**VARIOUS LOCALES AS INDICATED**  
**BY ORDER**

DATE PRINTED <b>11/19/2007</b>	TERMS OF SALE	SHIP VIA	F.O.B.	FREIGHT TERMS
-----------------------------------	---------------	----------	--------	---------------

BID OPENING DATE: **12/05/2007**      BID OPENING TIME **01:30PM**

LINE	QUANTITY	UOP	CAT NO	ITEM NUMBER	UNIT PRICE	AMOUNT
<p>WRITTEN STATE CONTRACT ORDER (FORM NUMBER WV-39) TO THE VENDOR FOR COMMODITIES COVERED BY THIS CONTRACT. THE ORIGINAL COPY OF THE WV-39 SHALL BE MAILED TO THE VENDOR AS AUTHORIZATION FOR SHIPMENT, A SECOND COPY MAILED TO THE PURCHASING DIVISION, AND A THIRD COPY RETAINED BY THE SPENDING UNIT.</p> <p>BANKRUPTCY: IN THE EVENT THE VENDOR/CONTRACTOR FILES FOR BANKRUPTCY PROTECTION, THIS CONTRACT IS AUTOMATICALLY NULL AND VOID, AND IS TERMINATED WITHOUT FURTHER ORDER.</p> <p>THE TERMS AND CONDITIONS CONTAINED IN THIS CONTRACT SHALL SUPERSEDE ANY AND ALL SUBSEQUENT TERMS AND CONDITIONS WHICH MAY APPEAR ON ANY ATTACHED PRINTED DOCUMENTS SUCH AS PRICE LISTS, ORDER FORMS, SALES AGREEMENTS OR MAINTENANCE AGREEMENTS, INCLUDING ANY ELECTRONIC MEDIUM SUCH AS CD-ROM.</p> <p>REV. 04/11/2001</p> <p>PURCHASING CARD ACCEPTANCE: THE STATE OF WEST VIRGINIA CURRENTLY UTILIZES A VISA PURCHASING CARD PROGRAM WHICH IS ISSUED THROUGH A BANK. THE SUCCESSFUL VENDOR MUST ACCEPT THE STATE OF WEST VIRGINIA VISA PURCHASING CARD FOR PAYMENT OF ALL ORDERS PLACED BY ANY STATE AGENCY AS A CONDITION OF AWARD.</p> <p style="text-align: center;"><b>VENDOR PREFERENCE CERTIFICATE</b></p> <p>CERTIFICATION AND APPLICATION* IS HEREBY MADE FOR PREFERENCE IN ACCORDANCE WITH WEST VIRGINIA CODE, 5A-3-37 (DOES NOT APPLY TO CONSTRUCTION CONTRACTS).</p>						

SEE REVERSE SIDE FOR TERMS AND CONDITIONS

SIGNATURE	TELEPHONE	DATE
TITLE	FEIN	ADDRESS CHANGES TO BE NOTED ABOVE

WHEN RESPONDING TO RFQ, INSERT NAME AND ADDRESS IN SPACE ABOVE LABELED 'VENDOR'



State of West Virginia  
 Department of Administration  
 Purchasing Division  
 2019 Washington Street East  
 Post Office Box 50130  
 Charleston, WV 25305-0130

# Request for Quotation

RFQ NUMBER
708C0006

PAGE
4

ADDRESS CORRESPONDENCE TO ATTENTION OF:
MICHAEL AUSTIN 304-558-2402

VENDOR

\*709051756      304-346-5301  
 WV TRACTOR COMPANY  
 PO BOX 473  
 CHARLESTON WV 25322

SHIP TO

DIVISION OF HIGHWAYS  
 VARIOUS LOCALES AS INDICATED  
 BY ORDER

DATE PRINTED	TERMS OF SALE	SHIP VIA	F.O.B.	FREIGHT TERMS		
11/19/2007						
BID OPENING DATE: 12/05/2007		BID OPENING TIME 01:30PM				
LINE	QUANTITY	UOP	CAT. NO.	ITEM NUMBER	UNIT PRICE	AMOUNT
<p>A. APPLICATION IS MADE FOR 2.5% PREFERENCE FOR THE REASON CHECKED:</p> <p>( ) BIDDER IS AN INDIVIDUAL RESIDENT VENDOR AND HAS RESIDED CONTINUOUSLY IN WEST VIRGINIA FOR FOUR (4) YEARS IMMEDIATELY PRECEDING THE DATE OF THIS CERTIFICATION; OR</p> <p>(xx) BIDDER IS A PARTNERSHIP, ASSOCIATION OR CORPORATION RESIDENT VENDOR AND HAS MAINTAINED ITS HEAD-QUARTERS OR PRINCIPAL PLACE OF BUSINESS CONTINUOUSLY IN WEST VIRGINIA FOR FOUR (4) YEARS IMMEDIATELY PRECEDING THE DATE OF THIS CERTIFICATION; OR 80% OF THE OWNERSHIP INTEREST OF BIDDER IS HELD BY ANOTHER INDIVIDUAL, PARTNERSHIP, ASSOCIATION OR CORPORATION RESIDENT VENDOR WHO HAS MAINTAINED ITS HEADQUARTERS OR PRINCIPAL PLACE OF BUSINESS CONTINUOUSLY IN WEST VIRGINIA FOR FOUR (4) YEARS IMMEDIATELY PRECEDING THE DATE OF THIS CERTIFICATION; OR</p> <p>( ) BIDDER IS A CORPORATION NONRESIDENT VENDOR WHICH HAS AN AFFILIATE OR SUBSIDIARY WHICH EMPLOYS A MINIMUM OF ONE HUNDRED STATE RESIDENTS AND WHICH HAS MAINTAINED ITS HEADQUARTERS OR PRINCIPAL PLACE OF BUSINESS WITHIN WEST VIRGINIA CONTINUOUSLY FOR THE FOUR (4) YEARS IMMEDIATELY PRECEDING THE DATE OF THIS CERTIFICATION.</p> <p>B. APPLICATION IS MADE FOR 2.5% PREFERENCE FOR THE REASON CHECKED:</p> <p>(xx) BIDDER IS A RESIDENT VENDOR WHO CERTIFIES THAT, DURING THE LIFE OF THE CONTRACT, ON AVERAGE AT LEAST 75% OF THE EMPLOYEES WORKING ON THE PROJECT BEING BID ARE RESIDENTS OF WEST VIRGINIA WHO HAVE RESIDED IN THE STATE CONTINUOUSLY FOR THE TWO YEARS IMMEDIATELY</p>						
SEE REVERSE SIDE FOR TERMS AND CONDITIONS						
SIGNATURE			TELEPHONE		DATE	
TITLE		FEIN		ADDRESS CHANGES TO BE NOTED ABOVE		

WHEN RESPONDING TO RFQ, INSERT NAME AND ADDRESS IN SPACE ABOVE LABELED 'VENDOR'



State of West Virginia  
 Department of Administration  
 Purchasing Division  
 2019 Washington Street East  
 Post Office Box 50130  
 Charleston, WV 25305-0130

# Request for Quotation

RFQ NUMBER
708C0006

PAGE
5

ADDRESS CORRESPONDENCE TO ATTENTION OF:
MICHAEL AUSTIN 304-558-2402

RODNEY WIZBY

\*709051756      304-346-5301  
 WV TRACTOR COMPANY  
 PO BOX 473  
 CHARLESTON WV 25322

SHIP TO

DIVISION OF HIGHWAYS  
 VARIOUS LOCALES AS INDICATED  
 BY ORDER

DATE PRINTED	TERMS OF SALE	SHIP VIA	F.O.B.	FREIGHT TERMS
11/19/2007				

BID OPENING DATE: 12/05/2007      BID OPENING TIME 01:30PM

LINE	QUANTITY	UOP	CAT NO.	ITEM NUMBER	UNIT PRICE	AMOUNT
<p>PRECEDING SUBMISSION OF THIS BID;            OR            ( ) BIDDER IS A NONRESIDENT VENDOR EMPLOYING A MINIMUM OF ONE HUNDRED STATE RESIDENTS OR IS A NONRESIDENT VENDOR WITH AN AFFILIATE OR SUBSIDIARY WHICH MAINTAINS ITS HEADQUARTERS OR PRINCIPAL PLACE OF BUSINESS WITHIN WEST VIRGINIA EMPLOYING A MINIMUM OF ONE HUNDRED STATE RESIDENTS WHO CERTIFIES THAT, DURING THE LIFE OF THE CONTRACT, ON AVERAGE AT LEAST 75% OF THE EMPLOYEES OR BIDDERS' AFFILIATE'S OR SUBSIDIARY'S EMPLOYEES ARE RESIDENTS OF WEST VIRGINIA WHO HAVE RESIDED IN THE STATE CONTINUOUSLY FOR THE TWO YEARS IMMEDIATELY PRECEDING SUBMISSION OF THIS BID.</p> <p>BIDDER UNDERSTANDS IF THE SECRETARY OF TAX &amp; REVENUE DETERMINES THAT A BIDDER RECEIVING PREFERENCE HAS FAILED TO CONTINUE TO MEET THE REQUIREMENTS FOR SUCH PREFERENCE, THE SECRETARY MAY ORDER THE DIRECTOR OF PURCHASING TO: (A) RESCIND THE CONTRACT OR PURCHASE ORDER ISSUED; OR (B) ASSESS A PENALTY AGAINST SUCH BIDDER IN AN AMOUNT NOT TO EXCEED 5% OF THE BID AMOUNT AND THAT SUCH PENALTY WILL BE PAID TO THE CONTRACTING AGENCY OR DEDUCTED FROM ANY UNPAID BALANCE ON THE CONTRACT OR PURCHASE ORDER.</p> <p>BY SUBMISSION OF THIS CERTIFICATE, BIDDER AGREES TO DISCLOSE ANY REASONABLY REQUESTED INFORMATION TO THE PURCHASING DIVISION AND AUTHORIZES THE DEPARTMENT OF TAX AND REVENUE TO DISCLOSE TO THE DIRECTOR OF PURCHASING APPROPRIATE INFORMATION VERIFYING THAT BIDDER HAS PAID THE REQUIRED BUSINESS TAXES, PROVIDED THAT SUCH INFORMATION DOES NOT CONTAIN THE AMOUNTS OF TAXES PAID NOR ANY OTHER INFORMATION DEEMED BY THE TAX COMMISSIONER TO BE CONFIDENTIAL.</p> <p>UNDER PENALTY OF LAW FOR FALSE SWEARING (WEST VIRGINIA</p>						

SEE REVERSE SIDE FOR TERMS AND CONDITIONS

SIGNATURE	TELEPHONE	DATE
TITLE	FEIN	ADDRESS CHANGES TO BE NOTED ABOVE

WHEN RESPONDING TO RFQ, INSERT NAME AND ADDRESS IN SPACE ABOVE LABELED 'VENDOR'



State of West Virginia  
 Department of Administration  
 Purchasing Division  
 2019 Washington Street East  
 Post Office Box 50130  
 Charleston, WV 25305-0130

# Request for Quotation

RFQ NUMBER  
**708C0006**

PAGE  
**6**

ADDRESS CORRESPONDENCE TO ATTENTION OF  
**MICHAEL AUSTIN**  
**304-558-2402**

VENDOR

\*709051756      304-346-5301  
**WV TRACTOR COMPANY**  
**PO BOX 473**  
  
**CHARLESTON WV 25322**

SHIP TO

**DIVISION OF HIGHWAYS**  
**VARIOUS LOCALES AS INDICATED**  
**BY ORDER**

DATE PRINTED <b>11/19/2007</b>	TERMS OF SALE	SHIP VIA	F.O.B.	FREIGHT TERMS
-----------------------------------	---------------	----------	--------	---------------

BID OPENING DATE: **12/05/2007**      BID OPENING TIME **01:30PM**

LINE	QUANTITY	UOP	CAT NO	ITEM NUMBER	UNIT PRICE	AMOUNT
<p>CODE 61-5-3), BIDDER HEREBY CERTIFIES THAT THIS CERTIFICATE IS TRUE AND ACCURATE IN ALL RESPECTS; AND THAT IF A CONTRACT IS ISSUED TO BIDDER AND IF ANYTHING CONTAINED WITHIN THIS CERTIFICATE CHANGES DURING THE TERM OF THE CONTRACT, BIDDER WILL NOTIFY THE PURCHASING DIVISION IN WRITING IMMEDIATELY.</p> <p>BIDDER: <u>West Virginia Tractor Company</u></p> <p>DATE: <u>12/4/07</u></p> <p>SIGNED: <u><i>George Gray</i></u></p> <p>TITLE: <u>President</u></p> <p>* CHECK ANY COMBINATION OF PREFERENCE CONSIDERATION(S) IN EITHER "A" OR "B", OR BOTH "A" AND "B" WHICH YOU ARE ENTITLED TO RECEIVE. YOU MAY REQUEST UP TO THE MAXIMUM 5% PREFERENCE FOR BOTH "A" AND "B". (REV. 12/00)</p> <p>NOTICE</p> <p>A SIGNED BID MUST BE SUBMITTED TO:</p> <p>DEPARTMENT OF ADMINISTRATION          PURCHASING DIVISION          BUILDING 15          2019 WASHINGTON STREET, EAST          CHARLESTON, WV 25305-0130</p> <p>THE BID SHOULD CONTAIN THIS INFORMATION ON THE FACE OF</p>						

SEE REVERSE SIDE FOR TERMS AND CONDITIONS

SIGNATURE	TELEPHONE	DATE
TITLE	FEIN	ADDRESS CHANGES TO BE NOTED ABOVE

WHEN RESPONDING TO RFQ, INSERT NAME AND ADDRESS IN SPACE ABOVE LABELED 'VENDOR'



State of West Virginia  
 Department of Administration  
 Purchasing Division  
 2019 Washington Street East  
 Post Office Box 50130  
 Charleston, WV 25305-0130

# Request for Quotation

RFQ NUMBER
708C0006

PAGE
7

ADDRESS CORRESPONDENCE TO ATTENTION OF
MICHAEL AUSTIN 304-558-2402

V E N D O R	*709051756	304-346-5301
	WV TRACTOR COMPANY	
	PO BOX 473	
	CHARLESTON WV 25322	

S H I P T O	DIVISION OF HIGHWAYS
	VARIOUS LOCALES AS INDICATED BY ORDER

DATE PRINTED	TERMS OF SALE	SHIP VIA	F.O.B.	FREIGHT TERMS
11/19/2007				

BID OPENING DATE: 12/05/2007 BID OPENING TIME 01:30PM

LINE	QUANTITY	UOP	CAT NO	ITEM NUMBER	UNIT PRICE	AMOUNT
<p>THE ENVELOPE OR THE BID MAY NOT BE CONSIDERED:            SEALED BID</p> <p>BUYER: 33</p> <p>RFQ. NO.: 708C0006</p> <p>BID OPENING DATE: 12/05/2007</p> <p>BID OPENING TIME: 1:30 PM</p> <p>PLEASE PROVIDE A FAX NUMBER IN CASE IT IS NECESSARY TO CONTACT YOU REGARDING YOUR BID:            -----            346-5305            -----</p> <p>CONTACT PERSON (PLEASE PRINT CLEARLY):            -----            Gary Grady            -----</p> <p>***** THIS IS THE END OF RFQ 708C0006 ***** TOTAL: _____</p>						

SEE REVERSE SIDE FOR TERMS AND CONDITIONS			
SIGNATURE	TELEPHONE	DATE	
TITLE	FEIN	ADDRESS CHANGES TO BE NOTED ABOVE	

WHEN RESPONDING TO RFQ, INSERT NAME AND ADDRESS IN SPACE ABOVE LABELED 'VENDOR'

**BID SCHEDULE****DESCRIPTION – WAIN ROY SIDE ANGLE COUPLER SYSTEM**

	<b>Unit Price</b>
<b>1. NEW MANUAL SWINGER SIDE ANGLE COUPLER SYSTEM, 40 DEGREE ANGLE Powertilt PT-7</b>	<u>\$4,550</u>
<b>2. AUXILLARY HYDRAULIC KIT FOR COUPLER P.H.T.</b>	<u>\$ 650</u>
<b>3. NEW 36" GRADING BUCKET WITH BOLT ON EDGE C&amp;P 36049-D</b>	<u>\$1,500</u>

**MUST HAVE CAPABILITY OF QUICK DISCONNECT BUCKET BY REMOVAL OF PIN.**

**MUST BE COMPATABLE WITH BUCKET SUPPLIED BY MANUFACTURER CURRENTLY ON HOE.**

**EXISTING WAIN ROY BUCKET MUST FIT UNIT QUOTED.**

See detailed quotation with equipment descriptions attached.



Any late changes from the indicated delivery schedule without prior approval by the Division of Highways may be cause for cancellation.

**ORDERING INFORMATION:** Parts orders against this contract may be placed by the WV DOH Equipment Division and the ten (10) WVDOH District. These parts orders may be placed by telephone and /or facsimile.

**ORDERS LESS THAN \$100.00 MAY BE OBTAINED BY THE AGENCY USING ALTERNATE**

**DELIVERY:** Delivery shall be made to the WVDOT/DIVISION OF HIGHWAYS locations as shown on page **11**.

**ALL SHIPMENTS ARE TO BE FOB DESTINATION.**

**FREIGHT CHARGE WILL ONLY BE ALLOWED FOR 24 HR. SERVICE.**

Delivery is an integral part of this contract and failure to comply will be cause to initiate a D.O.T Administrative Form WV-82, Vendor Performance Form. The WV-82 Form will provide a means of officially notifying the Purchasing Division and the vendor of unsatisfactory performance; such as late deliveries, poor service, inadequate parts, supplies, etc.

All warranty claims that require field service shall be done by the vendor at no cost to the WV Division of Highways.

The vendor shall furnish any technical engineering service which might be needed in the proper installation of these parts at no extra cost to the WV Division of Highways.

**Material Safety Data Sheet:** In addition to meeting current Federal & State laws and requirements concerning Hazardous Chemicals, vendor shall forward with shipment a proper and current Material Safety Date Sheet (MSDS) to the Equipment Division in Buckhannon. Furthermore, vendor shall furnish the State and/or its agencies additional MSDS as requested. By offering and signing a bid response the vendor agrees to these conditions.

The vendor will furnish the State of West Virginia with current price lists and supplement sheets as published by each manufacturer as listed above, manuals and catalogs as may be required. The Department of Highways cannot process invoices for payment until the most current price list is received. Also the State Auditors Office will not approve any invoices for payment without the most current price list. **ALL DETAILS PERTAINING TO THE PRICE LISTS AND SUPPLEMENTS WILL BE HANDLED BY THE PROCURMENT OFFICE OF THE WEST VIRGINIA DIVISION OF HIGHWAYS, CHARLESTON, WV.** The Division of highways reserves the right to revise this section of the contract pertaining the district listing should the amount of the districts increase. The afore mentioned price lists should be forward directly to the addresses listed below:

Vendor must guarantee that he will maintain in his warehouse adequate stock to supply the needs of the WV Division of Highways at all times. ORDERS MUST NOT BE HELD BY THE VENDOR UNTIL A MAXIMUM ORDER POINT HAS BEEN REACHED. Orders should be delivered in a MAXIMUM OF THREE (3) WORKING DAYS OR THE WVDIVISION OF HIGHWAYS PARTS EXPEDITOR MAY GO OFF CONTRACT TO PURCHASE THE PARTS ON THE OPEN MARKET AFTER 5 DAYS WITH THE APPROVAL OF THE EQUIPMENT DIVISION DIRECTOR OR THE DISTRICT EQUIPMENT SUPERVISOR OR HIS DESIGNEE. ALL OPEN MARKET PURCHASES MUST BE MADE IN ACCORDANCE WITH THE DEPARTMENT OF ADMINISTRATION PURCHASING DIVISION REGULATIONS.

A restocking charge can only be attached by the vendor with prior mutual consent. Any new parts placed on the market by the manufacturer during the contract period shall be made available to the WV Division of Highways at the Manufacturers published Fleet price less the discount listed above.

All deliveries of merchandise and/or shipping documents at each organization must be properly marked on the outside of the carton showing the WV Division of Highways Purchase Order Number. Any material delivered without this information on the outside of the carton or on documents will be returned to the shipper at shipper expense.

***Equipment Division***

WV Division of Highways  
PO Box 610  
Buckhannon, WV 26201  
ATTENTION: Kevin Riley (FOUR COPYS)

WVDOT/Division of Highways  
D-1  
1340 Smith St.  
Charleston, WV 25301  
Attn: Melissa Mullens

WVDOT/Divison of Highways  
D-2  
Po. Box 880  
Huntington, WV 25712  
Attn: Keith Chapman

WVDOT/Division of Highways  
D-3  
626 Depot St.  
Parkersburg, WV 26101  
Attn: Mark Kimes

WVDOT/Division of Highways  
D-4  
P.O. BOX 2570  
Clarksburg, WV 26301  
Attn: John Bartlett

WVDOT/Division of Highways  
D-5  
PO BOX 99  
BURLINGTON, WV 26710  
Attn: Pat Broadhurst

WVDOT/Division of Highways  
D-6  
I DOT Drive.  
Moundsville, WV 26041-2353  
Attn: Carol Ryan

WVDOT/Division Highways  
D-7  
Drawer 1228  
Weston, WV 26452  
Attn: Melissa Jordan

WVDOT/Division of Highways  
D-8  
PO Box 1516  
Elkins, WV 26241  
Attn: Debbie Barnett

WVDOT/Division of Highways  
D-9  
103 ½ Church Street  
Lewisburg, WV 24901  
Attn: Keith Brown

WVDOT/Division of Highways  
D-10  
270 Hardwood Lane  
Princeton, WV 24740  
Attn: Tommy Camden

STATE OF WEST VIRGINIA  
Purchasing Division

## PURCHASING AFFIDAVIT

**West Virginia Code §5A-3-10a states:** No contract or renewal of any contract may be awarded by the state or any of its political subdivisions to any vendor or prospective vendor when the vendor or prospective vendor or a related party to the vendor or prospective vendor is a debtor and the debt owed is an amount greater than one thousand dollars in the aggregate

**DEFINITIONS:**

"Debt" means any assessment, premium, penalty, fine, tax or other amount of money owed to the state or any of its political subdivisions because of a judgment, fine, permit violation, license assessment, defaulted workers' compensation premium, penalty or other assessment presently delinquent or due and required to be paid to the state or any of its political subdivisions, including any interest or additional penalties accrued thereon.

"Debtor" means any individual, corporation, partnership, association, limited liability company or any other form or business association owing a debt to the state or any of its political subdivisions. "Political subdivision" means any county commission; municipality; county board of education; any instrumentality established by a county or municipality; any separate corporation or instrumentality established by one or more counties or municipalities, as permitted by law; or any public body charged by law with the performance of a government function or whose jurisdiction is coextensive with one or more counties or municipalities. "Related party" means a party, whether an individual, corporation, partnership, association, limited liability company or any other form or business association or other entity whatsoever, related to any vendor by blood, marriage, ownership or contract through which the party has a relationship of ownership or other interest with the vendor so that the party will actually or by effect receive or control a portion of the benefit, profit or other consideration from performance of a vendor contract with the party receiving an amount that meets or exceed five percent of the total contract amount.

**EXCEPTION:** The prohibition of this section does not apply where a vendor has contested any tax administered pursuant to chapter eleven of this code, workers' compensation premium, permit fee or environmental fee or assessment and the matter has not become final or where the vendor has entered into a payment plan or agreement and the vendor is not in default of any of the provisions of such plan or agreement.

**LICENSING:** Vendors must be licensed and in good standing in accordance with any and all state and local laws and requirements by any state or local agency of West Virginia, including, but not limited to, the West Virginia Secretary of State's Office, the West Virginia Tax Department, West Virginia Insurance Commission, or any other state agencies or political subdivision. Furthermore, the vendor must provide all necessary releases to obtain information to enable the Director or spending unit to verify that the vendor is licensed and in good standing with the above entities.

**CONFIDENTIALITY:** The vendor agrees that he or she will not disclose to anyone, directly or indirectly, any such personally identifiable information or other confidential information gained from the agency, unless the individual who is the subject of the information consents to the disclosure in writing or the disclosure is made pursuant to the agency's policies, procedures and rules. Vendors should visit [www.state.wv.us/admin/purchase/privacy](http://www.state.wv.us/admin/purchase/privacy) for the Notice of Agency Confidentiality Policies.

Under penalty of law for false swearing (West Virginia Code, §61-5-3), it is hereby certified that the vendor acknowledges the information in this said affidavit and are in compliance with the requirements as stated.

Vendor's Name: West Virginia Tractor Company

Authorized Signature: \_\_\_\_\_

Date: 12/4/07

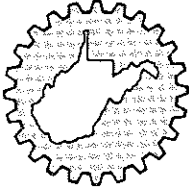

**WEST VIRGINIA  
TRACTOR COMPANY**  
CONSTRUCTION, MINING, MUNICIPAL & INDUSTRIAL EQUIPMENT

P.O. BOX 473, 214 VIRGINIA ST. W., CHARLESTON, WV 25322/25302 • (304) 346-5301

December 4, 2007

WV DOT-Highways  
Equipment Division  
P.O. Box 610  
Buckhannon, WV 26201

Subj: Tilt Coupler/Bucket Bid - RFQ 708C0006 - Due 12/5/07, 1:30 PM

Ladies and Gentlemen:

We are pleased to offer the following described equipment for your consideration:

POWERTILT Model PT-7 hydraulic bucket rotator attachment complete with an operating weight of 320 lbs., 180 degrees of total swing, 1.5-3 GPM oil flow required, and all standard equipment plus bucket mounting pins for use with your Terex TX760B backhoe loaders with extending stick and hammer hydraulics.

PRICE: F.O.B. Buckhannon or Charleston.....\$4,550 EA

P.H.T. diverter valve hydraulic kits to power the rotator through the Terex TX760B extending stick hydraulic circuit.

PRICE: F.O.B. Buckhannon or Charleston.....\$ 650 EA

C & P 36049-D 36" wide ditch cleaning/grading buckets, 11.42 cubic feet heaped and 8.85 cubic feet struck capacity with bolt-on cutting edge.

PRICE: F.O.B. Buckhannon or Charleston.....\$1,500 EA

TOTAL PRICE PER UNIT.....\$6,700

Terms: Net 30. Please note that by requiring us to accept payment by credit card, we have added additional money to our bid in order to compensate for the credit card charges we incur.

Availability: Currently about 30-45 days.

The WVDOH currently uses Powertilt attachments on Kobelco excavators and Terex TX760 backhoe loaders. The Powertilt can be used with the C & P grading bucket and the standard Terex buckets and any other pin-on buckets. Our quoted prices do not include installation, and you may have to supply some fittings and hoses. The Powertilt exceeds your specifications, especially the 180 degree swing in lieu of only 40 degree swing. Please refer to the attached WVDOH operator testimonial.

Page 2.

Manufacturers' standard warranty terms and conditions will apply to this proposal. Work under warranty to be performed at West Virginia Tractor Company in Charleston.

Please note that, as required by law, we are registered with the West Virginia Dept. of Tax and Revenue and Secretary of State and current with all taxes and license fees.

We qualify for and request the West Virginia Resident Vendor Preference in accordance with West Virginia Code 5A-3-37 and we have completed your Vendor Preference form. Our State of West Virginia Vendor ID Number is 709051756. Our West Virginia Tax ID is 013582.

Thank you very much for your consideration. If you have any questions or need any additional information, please feel free to call me on our toll free number, 1 800 640-8245, at any time. We invite you to visit us at [www.wvtractor.com](http://www.wvtractor.com). Again, thanks.

Sincerely,

A handwritten signature in black ink, appearing to read "Gary W. Grady". The signature is fluid and cursive, with the first letters of each word being capitalized and prominent.

Gary W. Grady, President



## Double Selector Package

### DSP12-PB-HL

The double selector package was designed to work with bucket tilt attachments. It utilizes an existing function, such as the stick function, and by shifting the VS245 or VS285 selector valve the stick control now operates the bucket tilt.

The PHT-DSP-HL-12 is a component only kit. The kit includes a VS245 or VS285 selector valve, two inline flow controls and control handle with wire harness. The standard voltage is 12vdc. No hose or fittings included in kit, customer to supply.

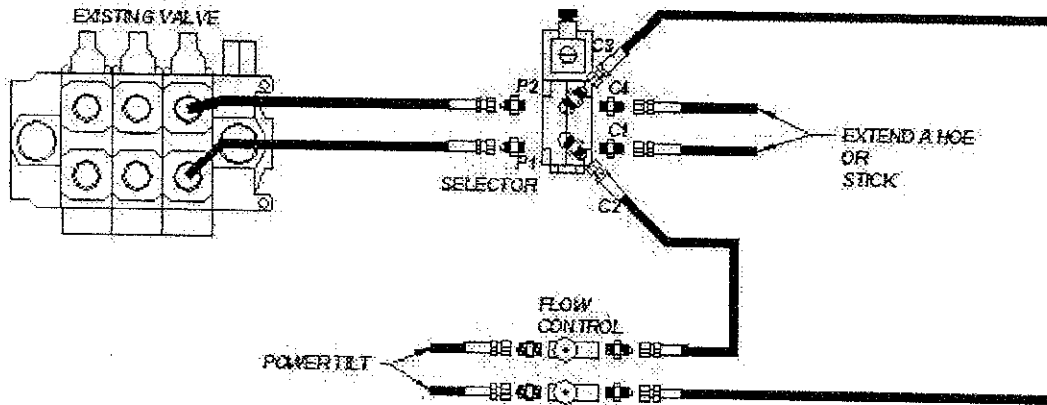

#### Specifications:

	VS245	VS285
Max PSI Int. Drain	3625 PSI	3625 PSI
Max PSI Ext. Drain	4350 PSI	4350 PSI
Max Flow	13 GPM	24 GPM
Ports	#8 ORB	#10 ORB
Voltage 12 VDC Standard , 24 VDC Optional		
Inline Flow Control Ports #6 ORB		



PHT Inc.-2201R Street NW Unit B-Auburn, WA 98001-Phone 253-735-8615-Fax 253-735-8615

Toll Free 800-929-4417-www.phtinc.com

# Ditch Cleaning Buckets

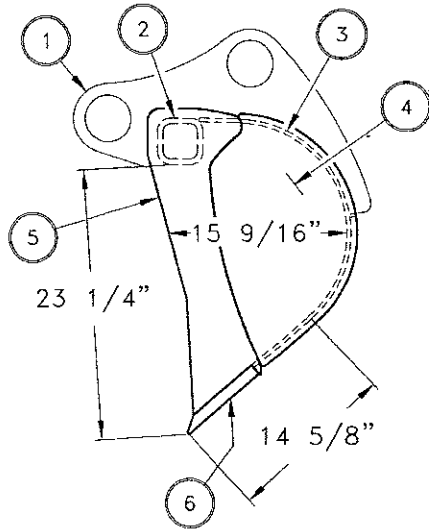

**RUBBER TIRE DITCH BUCKET — #025D**

Width	Struck Capacity	Rated Capacity	Teeth	Weight
36"	5.56	7.45		400
42"	6.56	8.78		450
48"	7.53	10.13		475
54"	8.53	11.45		525
60"	9.53	12.80		575

1. Hanger: 1 1/4"
2. 4 x 4 x 1/2"
3. Bottom: 5/16"
4. Sides: 5/16"
5. Side Cutters: 5/8" T-1
6. Cutting Edge: 1" x 8" T-1

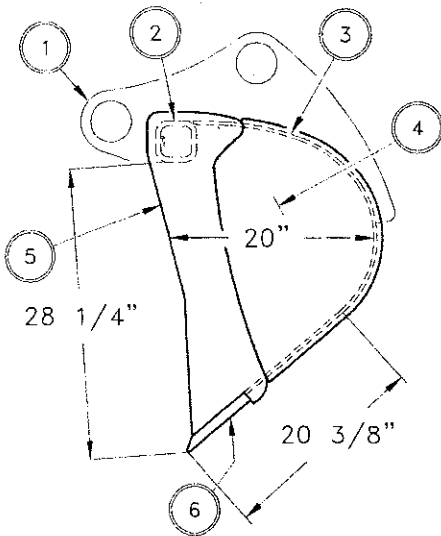

**RUBBER TIRE DITCH BUCKET — #049D**

Width	Struck Capacity	Rated Capacity	Teeth	Weight
12"	2.87	3.77		300
18"	4.10	5.36		350
24"	5.69	7.44		400
30"	7.26	9.52		450
36"	8.85	11.42		475

1. Hanger: 1 1/4"
2. 4 x 4 x 1/2"
3. Bottom: 5/16"
4. Sides: 5/16"
5. Side Cutters: 5/8" T-1
6. Cutting Edge: 1" x 8" T-1

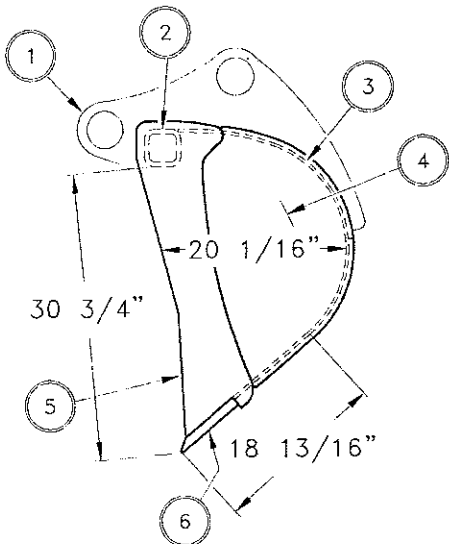

**RUBBER TIRE DITCH BUCKET — #050D**

Width	Struck Capacity	Rated Capacity	Teeth	Weight
12"	3.02	3.97		300
18"	4.32	5.64		350
24"	5.99	7.83		400
30"	7.64	10.02		450
36"	9.32	12.20		475

1. Hanger: 1 1/4"
2. 4 x 4 x 1/2"
3. Bottom: 5/16"
4. Sides: 5/16"
5. Side Cutters: 5/8" T-1
6. Cutting Edge: 1" x 8" T-1





## Warranty Information

Helac Corporation warrants its products to be free from defective material and factory workmanship for a period of one (1) year or 1,000 service hours, whichever occurs first, for Helac Corporation approved applications, defined as medium duty service on the machine for which the Helac Attachment (PowerTilt® or PowerGrip®) was originally designed and with cross port or work port relief valves installed according to Helac Corporation's recommendations. The warranty period shall begin when the Helac Attachment is first placed into service as documented by the return of the Warranty Registration Card to the factory. If the Registration Card is not returned, the warranty period will commence from the date the Helac Attachment was originally shipped from the factory. For products delivered from authorized dealer inventories, the warranty period shall commence no more than one (1) year from date of shipment from the factory.

This warranty shall be voided as to any products which have been repaired, worked upon, or altered by persons not authorized by Helac Corporation, or which have been subject to misuse, misapplication, negligence, accident, overload, field alteration, severe use or service applications beyond what the Helac Attachment was designed to perform. In no event shall Helac Corporation be liable for any incidental or consequential damages or claims including, but not limited to, the application in which the product was placed, field travel, freight charges, oil samples, downtime, etc. Warranty related repair and/or replacement issues will be satisfied according to how the product was originally purchased:

### **DIRECT SALES TO END-USERS**

This warranty covers repair or replacement of product or parts, which under normal use and service disclose defective material and/or factory workmanship. Only repairs completed at the Helac factory or factory replacement (at Helac's option) will satisfy claims under this warranty. Products under warranty shall be returned to the Helac factory for evaluation and repair. The customer shall contact the Helac Warranty Department for a Return Authorization Number prior to shipping the product in question. The factory will not accept products returned without a Return Authorization Number. Transportation shall be prepaid by the purchaser. On receipt, Helac factory personnel will inspect the product for warrantable issue(s). Upon warranty acceptance, Helac Corporation will repair the warranty issue(s) of the product at no cost to the customer and return the product freight prepaid. If it is determined that the issue(s) are not covered by the warranty, the product (repaired or not) will be returned COD to the customer.

### **SALES THROUGH EQUIPMENT DEALERS**

This warranty covers labor at predetermined, fixed flat rates and repair or replacement of products or parts, which under normal use and service disclose defective material and factory workmanship. Claims under this warranty will be satisfied only by repair or replacement of the unit or any defective part thereof. Products under warranty shall be returned to a factory authorized dealership location, transportation prepaid by the purchaser, for inspection by the dealer with factory consultation. Warranty repairs are only to be made at the selling dealer's location according to time maximums and at rates pre-established by Helac Corporation.

Helac Corporation reserves the right to make changes in the design or construction of any of its products at any time without incurring any obligations to make changes or alterations to products previously sold.

Helac Corporation reserves the right to alter this warranty and/or its terms at any time.

This warranty is in lieu of all other and/or prior warranties, expressed or implied, and no other company or person is authorized to represent or assume for Helac Corporation any liability in connection with the sale of Helac Corporation products other than set forth herein.

July 2005

**SPECIFICATIONS FOR A TILTING BUCKET ATTACHMENT  
WITH BUILT-IN QUICK-COUPLER COMPATIBLE WITH OEM BUCKETS  
Backhoe/Loaders and Excavators**

**Description:** Hydraulically activated bucket tilting attachment device that provides side-to-side bucket tilt ability and includes an integral mechanical quick coupler that is compatible with the carrier OEM's buckets. Attachment must be sized according to the attachment manufacturer's specifications for the backhoe/loader or excavator listed below:

Backhoe/Loader or  
Excavator  
Manufacturer \_\_\_\_\_ Model \_\_\_\_\_

**Important:** The carrier must be equipped with a 2-way hydraulic auxiliary tool circuit to operate the bucket tilting attachment.

- The carrier IS (existing machine) / IS TO BE (new machine) equipped with the required circuit
- The carrier IS NOT equipped with the required circuit — a circuit will be needed

MINIMUM BID SPECIFICATIONS	ATTACHMENT BEING BID
Manufacturer _____	Manufacturer _____
Model _____	Model _____
Must provide the following minimum side-to-side bucket tilt:	_____ Degrees of bucket tilt on attachment being bid
<ul style="list-style-type: none"> <li><input type="checkbox"/> 180° (90° to the left, 90° to the right) for 12' to 16' backhoe/loaders (Boom reach with retracted extendable dipper, if equipped)</li> <li><input type="checkbox"/> 180° (90° to the left, 90° to the right) for 4 to 6 ton excavators</li> <li><input type="checkbox"/> 134° (67° to the left, 67° to the right) for all other excavators</li> </ul>	<ul style="list-style-type: none"> <li><input type="checkbox"/> Yes      <input type="checkbox"/> No</li> <li><input type="checkbox"/> Yes      <input type="checkbox"/> No</li> <li><input type="checkbox"/> Yes      <input type="checkbox"/> No</li> <li><input type="checkbox"/> Yes      <input type="checkbox"/> No</li> </ul>
Must allow use of OEM specification bucket(s)	
Must include integral mechanical quick coupler	
Must provide constant bucket tilt speed and torque through full range of movement	
Bucket position holding must be two times the hydraulic tilt force	

Comments

**SPECIFICATIONS FOR A TILTING BUCKET ATTACHMENT  
WITH BUILT-IN UNIVERSAL QUICK HITCH COUPLER  
Backhoe/Loaders and Excavators**

**Description:** Hydraulically activated bucket tilting attachment device that provides side-to-side bucket tilt ability and includes an integral universal quick hitch coupler. Attachment must be sized according to the attachment manufacturer's specifications for the backhoe/loader or excavator listed below:

Backhoe/Loader or  
Excavator  
Manufacturer \_\_\_\_\_ Model \_\_\_\_\_

**Important:** The carrier must be equipped with a 2-way hydraulic auxiliary tool circuit to operate the bucket tilting attachment.

- The carrier IS (existing machine) / IS TO BE (new machine) equipped with the required circuit
- The carrier IS NOT equipped with the required circuit — a circuit will be needed

**MINIMUM BID SPECIFICATIONS**

Manufacturer \_\_\_\_\_

Model \_\_\_\_\_

Must provide the following minimum side-to-side bucket tilt:

- 180° (90° to the left, 90° to the right) for 12' to 16' backhoe/loaders (Boom reach with retracted extendable dipper, if equipped)
- 180° (90° to the left, 90° to the right) for 4 to 6 ton excavators
- 134° (67° to the left, 67° to the right) for all other excavators

Must allow use of universal quick hitch bucket(s)

Must include integral universal quick hitch coupler that will fit C&P Attachments or Woods Wain-Roy® style universal quick hitch buckets

Must provide constant bucket tilt speed and torque through full range of movement

Bucket position holding must be two times the hydraulic tilt force

**ATTACHMENT BEING BID**

Manufacturer \_\_\_\_\_

Model \_\_\_\_\_

\_\_\_\_\_ Degrees of bucket tilt on attachment being bid

Yes       No

Yes       No

Yes       No

Yes       No

Comments

## SPECIFICATIONS FOR A "4-IN-1" BACKHOE BUCKET Backhoe/Loaders and Excavators

**Description:** Backhoe bucket with hydraulically activated gripping clam. Bucket must be sized according to the bucket manufacturer's specifications for the backhoe/loader or excavator listed below:

Backhoe/Loader or  
Excavator

Manufacturer \_\_\_\_\_ Model \_\_\_\_\_

Bucket Width\*     24"     30"     36"     48"     60"     Other \_\_\_\_\_

**Important:** The carrier must be equipped with a 2-way hydraulic auxiliary tool circuit to operate the moveable clam.

- The carrier IS (existing machine) / IS TO BE (new machine) equipped with the required circuit
- The carrier IS NOT equipped with the required circuit — a circuit will be needed

\* Contact vendors to confirm availability of size specified

MINIMUM BID SPECIFICATIONS	BUCKET BEING BID
Manufacturer _____	Manufacturer _____
Model _____	Model _____
Lugged to OEM specification bucket(s)	<input type="checkbox"/> Yes <input type="checkbox"/> No
Clam driven on both sides	<input type="checkbox"/> Yes <input type="checkbox"/> No
No moving parts or obstructions inside bucket shell	<input type="checkbox"/> Yes <input type="checkbox"/> No
Clam not powered by linear hydraulic cylinder(s)	<input type="checkbox"/> Yes (No cylinders) <input type="checkbox"/> No (Has cylinders)
Clam opens to 120°	<input type="checkbox"/> Yes <input type="checkbox"/> No
Clam speed and torque are constant through full range of movement	<input type="checkbox"/> Yes <input type="checkbox"/> No
Bucket clam position holding force is four times the hydraulic clamping force	<input type="checkbox"/> Yes <input type="checkbox"/> No
Integral load holding valve with overload protection	<input type="checkbox"/> Yes <input type="checkbox"/> No
Serrated edges on bucket shell and clam	<input type="checkbox"/> Yes <input type="checkbox"/> No

Comments