



State of West Virginia
 Department of Administration
 Purchasing Division
 2019 Washington Street East
 Post Office Box 50130
 Charleston, WV 25305-0130

Request for Quotation

RFQ NUMBER
708C0003

PAGE
1

ADDRESS CORRESPONDENCE TO ATTENTION OF
**JOHN JOHNSTON
 304-558-2402**

***709051756 304-346-5301**
WV TRACTOR COMPANY
PO BOX 473

CHARLESTON WV 25322

DIVISION OF HIGHWAYS
VARIOUS LOCALES AS INDICATED
BY ORDER

| | | | | |
|-----------------------------------|--------------------------------|--------------------------|----------------------------|---------------------------------|
| DATE PRINTED 08/28/2007 | TERMS OF SALE Net 30 | SHIP VIA Truck | FOB As indicated | FREIGHT TERMS Prepaid |
|-----------------------------------|--------------------------------|--------------------------|----------------------------|---------------------------------|

BID OPENING DATE: **09/18/2007** **BID OPENING TIME 01:30PM**

| LINE | QUANTITY | UOP | CAT. NO. | ITEM NUMBER | UNIT PRICE | AMOUNT |
|--|----------|-----|----------|--|----------------|--------|
| 0001 | 1 | EA | | 060-74 AMULET TILT BUCKET TEREX MODEL TX760B LOADER, BOOM SWIVEL | PARTS OR EQUAL | |
| <p>OPEN END CONTRACT</p> <p>TO PROVIDE TEREX MODEL TX760B LOADER, BACKHOE BOOM SWIVEL PARTS WHICH MAY BE REQUIRED BY THE WEST VIRGINIA DIVISION OF HIGHWAYS.</p> <p>THIS CONTRACT EXCLUDES THE PURCHASE OF WHOLE UNIT COMPONENTS WHICH MAY BE LISTED WITHIN THE MANUFACTURE'S PRICE LIST. PER THE ATTACHED</p> <p>THIS CONTRACT TO INCLUDE THE FOLLOWING LISTED ON PG. 8 EXHIBIT 3</p> <p>LIFE OF CONTRACT: THIS CONTRACT BECOMES EFFECTIVE ON AND EXTENDS FOR A PERIOD OF ONE (1) YEAR OR UNTIL SUCH "REASONABLE TIME" THEREAFTER AS IS NECESSARY TO OBTAIN A NEW CONTRACT OR RENEW THE ORIGINAL CONTRACT. THE "REASONABLE TIME" PERIOD SHALL NOT EXCEED TWELVE (12) MONTHS. DURING THIS "REASONABLE TIME" THE VENDOR MAY TERMINATE THIS CONTRACT FOR ANY REASON UPON GIVING THE DIRECTOR OF PURCHASING 30 DAYS WRITTEN NOTICE.</p> <p>UNLESS SPECIFIC PROVISIONS ARE STIPULATED ELSEWHERE IN THIS CONTRACT DOCUMENT, THE TERMS, CONDITIONS AND PRICING SET HEREIN ARE FIRM FOR THE LIFE OF THE CONTRACT.</p> <p>RENEWAL: THIS CONTRACT MAY BE RENEWED UPON THE MUTUAL</p> | | | | | | |

SEE REVERSE SIDE FOR TERMS AND CONDITIONS

| | | |
|---------------------------------|------------------------------|-----------------------------------|
| SIGNATURE <i>[Signature]</i> | TELEPHONE 346-5301 | DATE 6 weeks |
| TITLE Pres | FEIN 550621655 | ADDRESS CHANGES TO BE NOTED ABOVE |

WHEN RESPONDING TO RFQ, INSERT NAME AND ADDRESS IN SPACE ABOVE LABELED 'VENDOR'



State of West Virginia
 Department of Administration
 Purchasing Division
 2019 Washington Street East
 Post Office Box 50130
 Charleston, WV 25305-0130

Request for Quotation

RFO NUMBER
708C0003

PAGE
2

ADDRESS CORRESPONDENCE TO ATTENTION OF:
JOHN JOHNSTON
304-558-2402

RODNEY WILSON

*709051756 304-346-5301
 WV TRACTOR COMPANY
 PO BOX 473
 CHARLESTON WV 25322

SHIP TO

DIVISION OF HIGHWAYS
 VARIOUS LOCALES AS INDICATED
 BY ORDER

| | | | | |
|--------------|---------------|----------|--------|---------------|
| DATE PRINTED | TERMS OF SALE | SHIP VIA | F.O.B. | FREIGHT TERMS |
| 08/28/2007 | | | | |

BID OPENING DATE: **09/18/2007** BID OPENING TIME **01:30PM**

| LINE | QUANTITY | UOP | CAT. NO. | ITEM NUMBER | UNIT PRICE | AMOUNT |
|--|----------|-----|----------|-------------|------------|--------|
| <p>WRITTEN CONSENT OF THE SPENDING UNIT AND VENDOR, SUBMITTED TO THE DIRECTOR OF PURCHASING THIRTY (30) DAYS PRIOR TO THE EXPIRATION DATE. SUCH RENEWAL SHALL BE IN ACCORDANCE WITH THE TERMS AND CONDITIONS OF THE ORIGINAL CONTRACT AND SHALL BE LIMITED TO TWO (2) ONE (1) YEAR PERIODS.</p> <p>CANCELLATION: THE DIRECTOR OF PURCHASING RESERVES THE RIGHT TO CANCEL THIS CONTRACT IMMEDIATELY UPON WRITTEN NOTICE TO THE VENDOR IF THE COMMODITIES AND/OR SERVICES SUPPLIED ARE OF AN INFERIOR QUALITY OR DO NOT CONFORM TO THE SPECIFICATIONS OF THE BID AND CONTRACT HEREIN.</p> <p>OPEN MARKET CLAUSE: THE DIRECTOR OF PURCHASING MAY AUTHORIZE A SPENDING UNIT TO PURCHASE ON THE OPEN MARKET, WITHOUT THE FILING OF A REQUISITION OR COST ESTIMATE, ITEMS SPECIFIED ON THIS CONTRACT FOR IMMEDIATE DELIVERY IN EMERGENCIES DUE TO UNFORESEEN CAUSES (INCLUDING BUT NOT LIMITED TO DELAYS IN TRANSPORTATION OR AN UNANTICIPATED INCREASE IN THE VOLUME OF WORK.)</p> <p>QUANTITIES: QUANTITIES LISTED IN THE REQUISITION ARE APPROXIMATIONS ONLY, BASED ON ESTIMATES SUPPLIED BY THE STATE SPENDING UNIT. IT IS UNDERSTOOD AND AGREED THAT THE CONTRACT SHALL COVER THE QUANTITIES ACTUALLY ORDERED FOR DELIVERY DURING THE TERM OF THE CONTRACT, WHETHER MORE OR LESS THAN THE QUANTITIES SHOWN.</p> <p>ORDERING PROCEDURE: SPENDING UNIT(S) SHALL ISSUE A WRITTEN STATE CONTRACT ORDER (FORM NUMBER WV-39) TO THE VENDOR FOR COMMODITIES COVERED BY THIS CONTRACT. THE ORIGINAL COPY OF THE WV-39 SHALL BE MAILED TO THE VENDOR AS AUTHORIZATION FOR SHIPMENT, A SECOND COPY MAILED TO THE PURCHASING DIVISION, AND A THIRD COPY RETAINED BY THE SPENDING UNIT.</p> | | | | | | |

SEE REVERSE SIDE FOR TERMS AND CONDITIONS

| | | |
|-----------|-----------|-----------------------------------|
| SIGNATURE | TELEPHONE | DATE |
| TITLE | FEIN | ADDRESS CHANGES TO BE NOTED ABOVE |

WHEN RESPONDING TO RFQ, INSERT NAME AND ADDRESS IN SPACE ABOVE LABELED 'VENDOR'



State of West Virginia
 Department of Administration
 Purchasing Division
 2019 Washington Street East
 Post Office Box 50130
 Charleston, WV 25305-0130

Request for Quotation

| |
|------------|
| RFQ NUMBER |
| 708C0003 |

| |
|------|
| PAGE |
| 3 |

| |
|--|
| ADDRESS CORRESPONDENCE TO ATTENTION OF |
| JOHN JOHNSTON 304-558-2402 |

VENDOR

*709051756 304-346-5301
 WV TRACTOR COMPANY
 PO BOX 473
 CHARLESTON WV 25322

SHIP TO

DIVISION OF HIGHWAYS
 VARIOUS LOCALES AS INDICATED
 BY ORDER

| DATE PRINTED | TERMS OF SALE | SHIP VIA | F.O.B. | FREIGHT TERMS |
|------------------------------|---------------|--------------------------|--------|---------------|
| 08/28/2007 | | | | |
| BID OPENING DATE: 09/18/2007 | | BID OPENING TIME 01:30PM | | |

| LINE | QUANTITY | UOP | CAT. NO. | ITEM NUMBER | UNIT PRICE | AMOUNT |
|---|----------|-----|----------|-------------|------------|--------|
| <p>BANKRUPTCY: IN THE EVENT THE VENDOR/CONTRACTOR FILES FOR BANKRUPTCY PROTECTION, THIS CONTRACT IS AUTOMATICALLY NULL AND VOID, AND IS TERMINATED WITHOUT FURTHER ORDER.</p> <p>THE TERMS AND CONDITIONS CONTAINED IN THIS CONTRACT SHALL SUPERSEDE ANY AND ALL SUBSEQUENT TERMS AND CONDITIONS WHICH MAY APPEAR ON ANY ATTACHED PRINTED DOCUMENTS SUCH AS PRICE LISTS, ORDER FORMS, SALES AGREEMENTS OR MAINTENANCE AGREEMENTS, INCLUDING ANY ELECTRONIC MEDIUM SUCH AS CD-ROM.</p> <p>REV. 04/11/2001</p> <p style="text-align: center;">VENDOR PREFERENCE CERTIFICATE</p> <p>CERTIFICATION AND APPLICATION* IS HEREBY MADE FOR PREFERENCE IN ACCORDANCE WITH WEST VIRGINIA CODE, 5A-3-37 (DOES NOT APPLY TO CONSTRUCTION CONTRACTS).</p> <p>A. APPLICATION IS MADE FOR 2.5% PREFERENCE FOR THE REASON CHECKED:</p> <p>() BIDDER IS AN INDIVIDUAL RESIDENT VENDOR AND HAS RESIDED CONTINUOUSLY IN WEST VIRGINIA FOR FOUR (4) YEARS IMMEDIATELY PRECEDING THE DATE OF THIS CERTIFICATION; OR</p> <p>(XX) BIDDER IS A PARTNERSHIP, ASSOCIATION OR CORPORATION RESIDENT VENDOR AND HAS MAINTAINED ITS HEAD-QUARTERS OR PRINCIPAL PLACE OF BUSINESS CONTINUOUSLY IN WEST VIRGINIA FOR FOUR (4) YEARS IMMEDIATELY PRECEDING THE DATE OF THIS CERTIFICATION; OR 80% OF THE OWNERSHIP INTEREST OF BIDDER IS HELD BY ANOTHER INDIVIDUAL,</p> | | | | | | |

SEE REVERSE SIDE FOR TERMS AND CONDITIONS

| | | |
|-----------|-----------|-----------------------------------|
| SIGNATURE | TELEPHONE | DATE |
| TITLE | FEIN | ADDRESS CHANGES TO BE NOTED ABOVE |

WHEN RESPONDING TO RFQ, INSERT NAME AND ADDRESS IN SPACE ABOVE LABELED 'VENDOR'



State of West Virginia
 Department of Administration
 Purchasing Division
 2019 Washington Street East
 Post Office Box 50130
 Charleston, WV 25305-0130

Request for Quotation

RFO NUMBER
708C0003

PAGE
4

ADDRESS CORRESPONDENCE TO ATTENTION OF:
JOHN JOHNSTON
304-558-2402

VENDOR

*709051756 304-346-5301
WV TRACTOR COMPANY
PO BOX 473

CHARLESTON WV 25322

SHIP TO

DIVISION OF HIGHWAYS
VARIOUS LOCALES AS INDICATED
BY ORDER

| DATE PRINTED | TERMS OF SALE | SHIP VIA | F.O.B. | FREIGHT TERMS |
|--------------|---------------|----------|--------|---------------|
| 08/28/2007 | | | | |

BID OPENING DATE: **09/18/2007** BID OPENING TIME **01:30PM**

| LINE | QUANTITY | UOP | CAT. NO. | ITEM NUMBER | UNIT PRICE | AMOUNT |
|--|----------|-----|----------|-------------|------------|--------|
| <p>PARTNERSHIP, ASSOCIATION OR CORPORATION RESIDENT VENDOR WHO HAS MAINTAINED ITS HEADQUARTERS OR PRINCIPAL PLACE OF BUSINESS CONTINUOUSLY IN WEST VIRGINIA FOR FOUR (4) YEARS IMMEDIATELY PRECEDING THE DATE OF THIS CERTIFICATION; OR</p> <p>() BIDDER IS A CORPORATION NONRESIDENT VENDOR WHICH HAS AN AFFILIATE OR SUBSIDIARY WHICH EMPLOYS A MINIMUM OF ONE HUNDRED STATE RESIDENTS AND WHICH HAS MAINTAINED ITS HEADQUARTERS OR PRINCIPAL PLACE OF BUSINESS WITHIN WEST VIRGINIA CONTINUOUSLY FOR THE FOUR (4) YEARS IMMEDIATELY PRECEDING THE DATE OF THIS CERTIFICATION.</p> <p>B. APPLICATION IS MADE FOR 2.5% PREFERENCE FOR THE REASON CHECKED:</p> <p>(xx) BIDDER IS A RESIDENT VENDOR WHO CERTIFIES THAT, DURING THE LIFE OF THE CONTRACT, ON AVERAGE AT LEAST 75% OF THE EMPLOYEES WORKING ON THE PROJECT BEING BID ARE RESIDENTS OF WEST VIRGINIA WHO HAVE RESIDED IN THE STATE CONTINUOUSLY FOR THE TWO YEARS IMMEDIATELY PRECEDING SUBMISSION OF THIS BID; OR () BIDDER IS A NONRESIDENT VENDOR EMPLOYING A MINIMUM OF ONE HUNDRED STATE RESIDENTS OR IS A NONRESIDENT VENDOR WITH AN AFFILIATE OR SUBSIDIARY WHICH MAINTAINS ITS HEADQUARTERS OR PRINCIPAL PLACE OF BUSINESS WITHIN WEST VIRGINIA EMPLOYING A MINIMUM OF ONE HUNDRED STATE RESIDENTS WHO CERTIFIES THAT, DURING THE LIFE OF THE CONTRACT, ON AVERAGE AT LEAST 75% OF THE EMPLOYEES OR BIDDERS' AFFILIATE'S OR SUBSIDIARY'S EMPLOYEES ARE RESIDENTS OF WEST VIRGINIA WHO HAVE RESIDED IN THE STATE CONTINUOUSLY FOR THE TWO YEARS IMMEDIATELY PRECEDING SUBMISSION OF THIS BID.</p> | | | | | | |

SEE REVERSE SIDE FOR TERMS AND CONDITIONS

| | | | |
|-----------|------|-----------------------------------|------|
| SIGNATURE | | TELEPHONE | DATE |
| TITLE | FEIN | ADDRESS CHANGES TO BE NOTED ABOVE | |

WHEN RESPONDING TO RFO, INSERT NAME AND ADDRESS IN SPACE ABOVE LABELED 'VENDOR'



State of West Virginia
 Department of Administration
 Purchasing Division
 2019 Washington Street East
 Post Office Box 50130
 Charleston, WV 25305-0130

Request for Quotation

| |
|------------|
| RFQ NUMBER |
| 708C0003 |

| |
|------|
| PAGE |
| 5 |

| |
|---|
| ADDRESS CORRESPONDENCE TO ATTENTION OF: |
| JOHN JOHNSTON 304-558-2402 |

VENDOR

*709051756 304-346-5301
 WV TRACTOR COMPANY
 PO BOX 473
 CHARLESTON WV 25322

SHIP TO

DIVISION OF HIGHWAYS
 VARIOUS LOCALES AS INDICATED
 BY ORDER

| | | | | |
|--------------|---------------|----------|--------|---------------|
| DATE PRINTED | TERMS OF SALE | SHIP VIA | F.O.B. | FREIGHT TERMS |
| 08/28/2007 | | | | |

BID OPENING DATE: **09/18/2007** BID OPENING TIME **01:30PM**

| LINE | QUANTITY | UOP | CAT. NO. | ITEM NUMBER | UNIT PRICE | AMOUNT |
|--|----------|-----|----------|-------------|------------|--------|
| <p>BIDDER UNDERSTANDS IF THE SECRETARY OF TAX & REVENUE DETERMINES THAT A BIDDER RECEIVING PREFERENCE HAS FAILED TO CONTINUE TO MEET THE REQUIREMENTS FOR SUCH PREFERENCE, THE SECRETARY MAY ORDER THE DIRECTOR OF PURCHASING TO: (A) RESCIND THE CONTRACT OR PURCHASE ORDER ISSUED; OR (B) ASSESS A PENALTY AGAINST SUCH BIDDER IN AN AMOUNT NOT TO EXCEED 5% OF THE BID AMOUNT AND THAT SUCH PENALTY WILL BE PAID TO THE CONTRACTING AGENCY OR DEDUCTED FROM ANY UNPAID BALANCE ON THE CONTRACT OR PURCHASE ORDER.</p> <p>BY SUBMISSION OF THIS CERTIFICATE, BIDDER AGREES TO DISCLOSE ANY REASONABLY REQUESTED INFORMATION TO THE PURCHASING DIVISION AND AUTHORIZES THE DEPARTMENT OF TAX AND REVENUE TO DISCLOSE TO THE DIRECTOR OF PURCHASING APPROPRIATE INFORMATION VERIFYING THAT BIDDER HAS PAID THE REQUIRED BUSINESS TAXES, PROVIDED THAT SUCH INFORMATION DOES NOT CONTAIN THE AMOUNTS OF TAXES PAID NOR ANY OTHER INFORMATION DEEMED BY THE TAX COMMISSIONER TO BE CONFIDENTIAL.</p> <p>UNDER PENALTY OF LAW FOR FALSE SWEARING (WEST VIRGINIA CODE 61-5-3), BIDDER HEREBY CERTIFIES THAT THIS CERTIFICATE IS TRUE AND ACCURATE IN ALL RESPECTS; AND THAT IF A CONTRACT IS ISSUED TO BIDDER AND IF ANYTHING CONTAINED WITHIN THIS CERTIFICATE CHANGES DURING THE TERM OF THE CONTRACT, BIDDER WILL NOTIFY THE PURCHASING DIVISION IN WRITING IMMEDIATELY.</p> <p style="text-align: right;">West Virginia Tractor Company</p> <p>BIDDER: -----</p> <p style="text-align: center;">9/14/07</p> <p>DATE: -----</p> | | | | | | |

SEE REVERSE SIDE FOR TERMS AND CONDITIONS

| | | |
|-----------|-----------|-----------------------------------|
| SIGNATURE | TELEPHONE | DATE |
| TITLE | FEIN | ADDRESS CHANGES TO BE NOTED ABOVE |

WHEN RESPONDING TO RFQ, INSERT NAME AND ADDRESS IN SPACE ABOVE LABELED 'VENDOR'



State of West Virginia
 Department of Administration
 Purchasing Division
 2019 Washington Street East
 Post Office Box 50130
 Charleston, WV 25305-0130

Request for Quotation

RFQ NUMBER:
708C0003

PAGE:
6

ADDRESS CORRESPONDENCE TO ATTENTION OF:
**JOHN JOHNSTON
 304-558-2402**

VENDOR RECORD

*709051756 304-346-5301
WV TRACTOR COMPANY
PO BOX 473

CHARLESTON WV 25322

SHIP TO

**DIVISION OF HIGHWAYS
 VARIOUS LOCALES AS INDICATED
 BY ORDER**

| DATE PRINTED | TERMS OF SALE | SHIP VIA | F.O.B. | FREIGHT TERMS | | |
|--|---------------|--------------------------|--------------------------|-----------------------------------|------------|--------|
| 08/28/2007 | | | | | | |
| BID OPENING DATE: 09/18/2007 | | BID OPENING TIME 01:30PM | | | | |
| LINE | QUANTITY | UOP | CAT. NO. | ITEM NUMBER | UNIT PRICE | AMOUNT |
| | | | SIGNED: <i>Gary Hoag</i> | | | |
| | | | TITLE: President | | | |
| <p>* CHECK ANY COMBINATION OF PREFERENCE CONSIDERATION(S) IN EITHER "A" OR "B", OR BOTH "A" AND "B" WHICH YOU ARE ENTITLED TO RECEIVE. YOU MAY REQUEST UP TO THE MAXIMUM 5% PREFERENCE FOR BOTH "A" AND "B". (REV. 12/00)</p> <p>NOTICE</p> <p>A SIGNED BID MUST BE SUBMITTED TO:</p> <p>DEPARTMENT OF ADMINISTRATION PURCHASING DIVISION BUILDING 15 2019 WASHINGTON STREET, EAST CHARLESTON, WV 25305-0130</p> <p>THE BID SHOULD CONTAIN THIS INFORMATION ON THE FACE OF THE ENVELOPE OR THE BID MAY NOT BE CONSIDERED:</p> <p>SEALED BID</p> <p>BUYER: 33</p> <p>RFQ. NO.: 708C0003</p> <p>BID OPENING DATE: 09/18/2007</p> | | | | | | |
| SEE REVERSE SIDE FOR TERMS AND CONDITIONS | | | | | | |
| SIGNATURE | | | TELEPHONE | | DATE | |
| TITLE | | FEIN | | ADDRESS CHANGES TO BE NOTED ABOVE | | |

WHEN RESPONDING TO RFQ, INSERT NAME AND ADDRESS IN SPACE ABOVE LABELED 'VENDOR'



State of West Virginia
 Department of Administration
 Purchasing Division
 2019 Washington Street East
 Post Office Box 50130
 Charleston, WV 25305-0130

Request for Quotation

| |
|------------|
| RFQ NUMBER |
| 708C0003 |

| |
|------|
| PAGE |
| 7 |

| |
|---|
| ADDRESS CORRESPONDENCE TO ATTENTION OF: |
| JOHN JOHNSTON 304-558-2402 |

| | | |
|----------------------------|---------------------|--------------|
| V E N D O R | *709051756 | 304-346-5301 |
| | WV TRACTOR COMPANY | |
| | PO BOX 473 | |
| | CHARLESTON WV 25322 | |

| | |
|----------------------------|--|
| S H I P T O | DIVISION OF HIGHWAYS |
| | VARIOUS LOCALES AS INDICATED BY ORDER |

| DATE PRINTED | TERMS OF SALE | SHIP VIA | F.O.B. | FREIGHT TERMS |
|--------------|---------------|----------|--------|---------------|
| 08/28/2007 | | | | |

BID OPENING DATE: **09/18/2007** BID OPENING TIME **01:30PM**

| LINE | QUANTITY | UOP | CAT. NO. | ITEM NUMBER | UNIT PRICE | AMOUNT |
|--|----------|-----|----------|-------------|------------|--------|
| <p>BID OPENING TIME: 1:30 PM</p> <p>PLEASE PROVIDE A FAX NUMBER IN CASE IT IS NECESSARY TO CONTACT YOU REGARDING YOUR BID: ----- 346-5305 -----</p> <p>CONTACT PERSON (PLEASE PRINT CLEARLY): ----- Gary Grady -----</p> <p>***** THIS IS THE END OF RFQ 708C0003 ***** TOTAL: _____</p> | | | | | | |

SEE REVERSE SIDE FOR TERMS AND CONDITIONS

| | | |
|-----------|-----------|-----------------------------------|
| SIGNATURE | TELEPHONE | DATE |
| TITLE | FEIN | ADDRESS CHANGES TO BE NOTED ABOVE |

WHEN RESPONDING TO RFQ, INSERT NAME AND ADDRESS IN SPACE ABOVE LABELED 'VENDOR'

**1. NEW MANUAL SWINGER SIDE ANGLE COUPLER
SYSTEM, 40 DEGREE ANGLE**

\$ 4,750

2. AUXILLARY HYDRAULIC KIT FOR COUPLER

750
\$-----

3. NEW 36" GRADING BUCKET WITH BOLT ON EDGE

Included in
\$-----
Item #1

This contract provides for the updating of the manufacturers price lists only, and the percent of discount remains constant throughout the life of contract. If the manufacturer changes parts numbers, add new parts, makes price changes, such changes may be obtained by submitting copies of the manufacturers changes of the published price list to all agencies listed .

Any late changes from the indicated delivery schedule without prior approval by the Division of Highways may be cause for cancellation.

ORDERING INFORMATION: Parts orders against this contract may be placed by the WV DOH Equipment Division and the ten (10) WVDOH District locations . These parts orders may be placed by telephone and /or facsimile.

ORDERS LESS THAN \$100.00 MAY BE OBTAINED BY THE AGENCY USING ALTERNATE PROCUREMENT METHODS.

METHOD OF PAYMENT: The Purchasing card (Visa) is the preferred method of payment. Vendor must supply a credit receipt, sales receipt, or cash register receipt. Vendor shall not charge until parts are shipped.

DELIVERY: Delivery shall be made to the WVDOT/DIVISION OF HIGHWAYS locations as shown .

ALL SHIPMENTS ARE TO BE FOB DESTINATION.

FREIGHT CHARGE WILL ONLY BE ALLOWED FOR 24 HR. SERVICE.

Delivery is an integral part of this contract and failure to comply will be cause to initiate a D.O.T Administrative Form WV-82, Vendor Performance Form. The WV-82 Form will provide a means of officially notifying the Purchasing Division and the vendor of unsatisfactory performance; such as late deliveries, poor service, inadequate parts, supplies, etc.

All warranty claims that require field service shall be done by the vendor at no cost to the WV Division of Highways.

The vendor shall furnish any technical engineering service which might be needed in the proper installation of these parts at no extra cost to the WV Division of Highways.

Material Safety Data Sheet: In addition to meeting current Federal & State laws and requirements concerning Hazardous Chemicals, vendor shall forward with shipment a proper and current Material Safety Date Sheet (MSDS) to the Equipment Division in Buckhannon. Furthermore, vendor shall furnish the State and/or its agencies additional MSDS as requested. By offering and signing a bid response the vendor agrees to these conditions.

The vendor will furnish the State of West Virginia with current price lists and supplement sheets as published by each manufacturer as listed above, manuals and catalogs as may be required. The Department of Highways cannot process invoices for payment until the most current price list is received. Also the State Auditors Office will not approve any invoices for payment without the most current price list. **ALL DETAILS PERTAINING TO THE PRICE LISTS AND SUPPLEMENTS WILL BE HANDLED BY THE PROCURMENT OFFICE OF THE WEST VIRGINIA DIVISION OF HIGHWAYS, CHARLESTON, WV.** The Division of highways reserves the right to revise this section of the contract pertaining the district listing should the amount of the districts increase. The afore mentioned price lists should be forward directly to the addresses listed below:

Vendor should provide a copy of manufacturers current price list with bid.

In the event of a tie, normal discount shall have precedence over 24 hrs. Service in evaluation process.

Bidder to complete: Mfg. Name Amulet

Date of Price List 1/1/07

Contract prices based upon current manufacturers published fleet prices less applicable discount:

DISCOUNT - %

DISCOUNT FOR 24 HOUR SERVICE +10 %

*DARTS ONLY
NOT FOR TILT BUCKET*

Vendor must guarantee that he will maintain in his warehouse adequate stock to supply the needs of the WV Division of Highways at all times. ORDERS MUST NOT BE HELD BY THE VENDOR UNTIL A MAXIMUM ORDER POINT HAS BEEN REACHED. Orders should be delivered in a MAXIMUM OF THREE (3) WORKING DAYS OR THE WVDIVISION OF HIGHWAYS PARTS EXPEDITOR MAY GO OFF CONTRACT TO PURCHASE THE PARTS ON THE OPEN MARKET AFTER 5 DAYS WITH THE APPROVAL OF THE EQUIPMENT DIVISION DIRECTOR OR THE DISTRICT EQUIPMENT SUPERVISOR OR HIS DESIGNEE. ALL OPEN MARKET PURCHASES MUST BE MADE IN ACCORDANCE WITH THE DEPARTMENT OF ADMINISTRATION PURCHASING DIVISION REGULATIONS.

A restocking charge can only be attached by the vendor with prior mutual consent. Any new parts placed on the market by the manufacturer during the contract period shall be made available to the WV Division of Highways at the Manufacturers published Fleet price less the discount listed above.

All deliveries of merchandise and/or shipping documents at each organization must be properly marked on the outside of the carton showing the WV Division of Highways Purchase Order Number. Any material delivered without this information on the outside of the carton or on documents will be returned to the shipper at shipper expense.

Equipment Division

WV Division of Highways
PO Box 610
Buckhannon, WV 26201
ATTENTION: Kevin Riley (FOUR COPYS)

WVDOT/Division of Highways
D-1
1340 Smith St.
Charleston, WV 25301
Attn: Melissa Mullens

WVDOT/Division of Highways
D-2
Po. Box 880
Huntington, WV 25712
Attn: Keith Chapman

WVDOT/Division of Highways
D-3
626 Depot St.
Parkersburg, WV 26101
Attn: Mark Kimes

WVDOT/Division of Highways
D-4
P.O. BOX 2570
Clarksburg, WV 26301
Attn: John Bartlett

WVDOT/Division of Highways
D-5
PO BOX 99
BURLINGTON, WV 26710
Attn: Pat Broadhurst

WVDOT/Division of Highways
D-6
1 DOT Drive.
Moundsville, WV 26041-2353
Attn: Carol Ryan

WVDOT/Division Highways
D-7
Drawer 1228
Weston, WV 26452
Attn: Melissa Jordan

WVDOT/Division of Highways
D-8
PO Box 1516
Elkins, WV 26241
Attn: Debbie Barnett

WVDOT/Division of Highways
D-9
103 ½ Church Street
Lewisburg, WV 24901
Attn: Keith Brown

WVDOT/Division of Highways
D-10
270 Hardwood Lane
Princeton, WV 24740
Attn: Tommy Camden



Double Selector Package

DSP12-PB-HL

The double selector package was designed to work with bucket tilt attachments. It utilizes an existing function, such as the stick function, and by shifting the VS245 or VS285 selector valve the stick control now operates the bucket tilt.

The PHT-DSP-HL-12 is a component only kit. The kit includes a VS245 or VS285 selector valve, two inline flow controls and control handle with wire harness. The standard voltage is 12vdc. No hose or fittings included in kit, customer to supply.

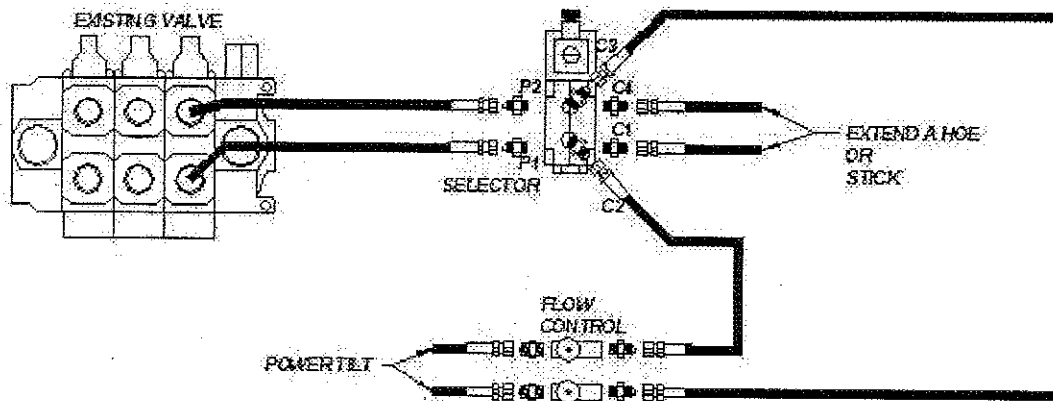

Specifications:

| | VS245 | VS285 |
|---|----------|----------|
| Max PSI Int. Drain | 3625 PSI | 3625 PSI |
| Max PSI Ext. Drain | 4350 PSI | 4350 PSI |
| Max Flow | 13 GPM | 24 GPM |
| Ports | #8 ORB | #10 ORB |
| Voltage 12 VDC Standard , 24 VDC Optional | | |
| Inline Flow Control Ports #6 ORB | | |



PHT Inc.-2201R Street NW Unit B-Auburn, WA 98001-Phone 253-735-8615-Fax 253-735-8615

Toll Free 800-929-4417-www.phtinc.com

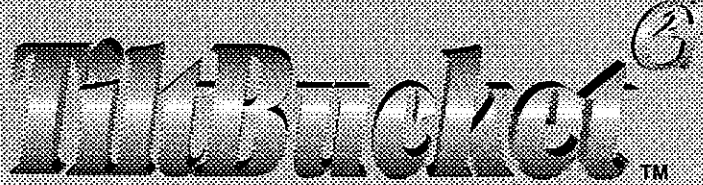
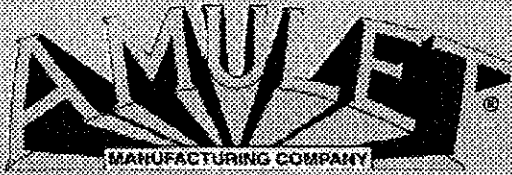

Ultimate Tool for Grading and Shaping Soil

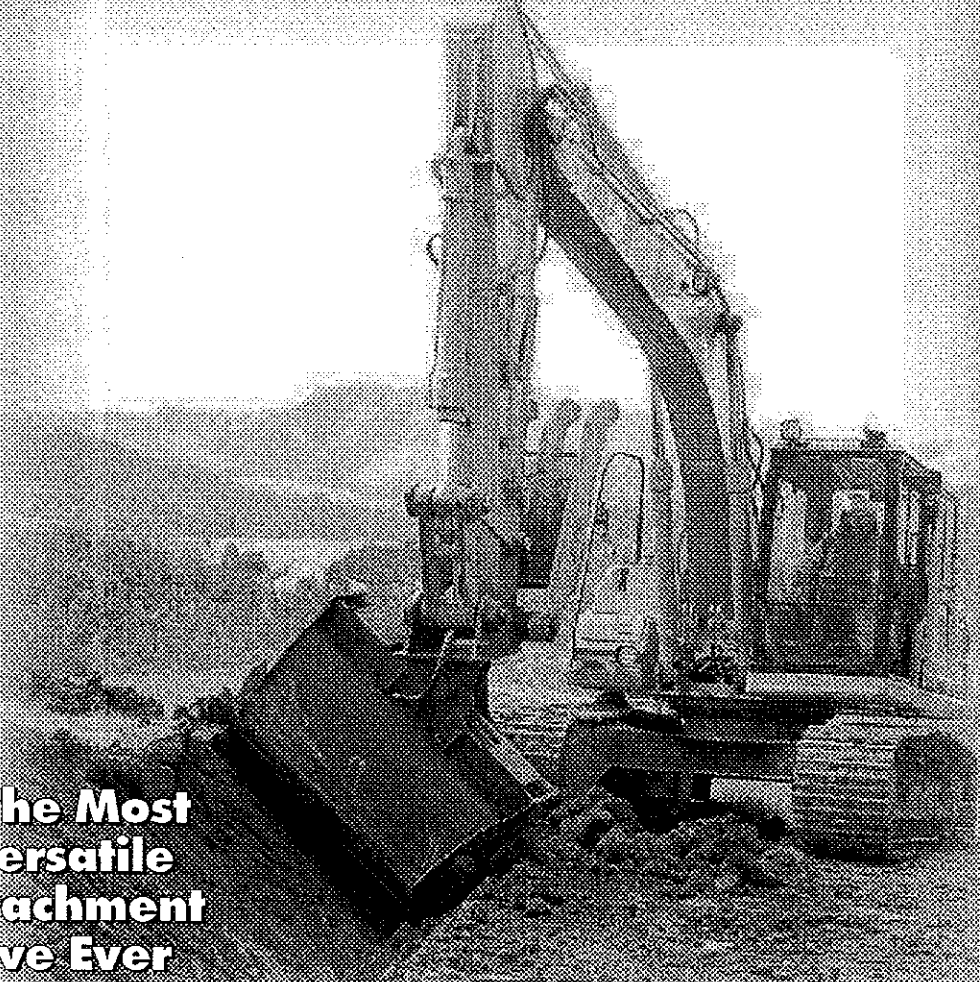

"The Most Versatile Attachment I've Ever Owned!"

Superior in Design - Superior in Quality

Sold and serviced by:



5640 West End Road • Arcata, CA 95521
Phone (707) 822-2282 • Fax 822-2398
Toll Free 800-526-8538
Visit Our Internet Web Site at amulet.com

PRICES AND SPECIFICATIONS SUBJECT TO CHANGE WITHOUT NOTICE. FOR MODEL PRICE & SPECIFICATIONS PLEASE CONTACT AMULET OR YOUR NEAREST DEALER.

AMULET

TiltBucket

Ultimate Grading and Shaping Tool

Amulet Hydraulic Tilt Buckets.

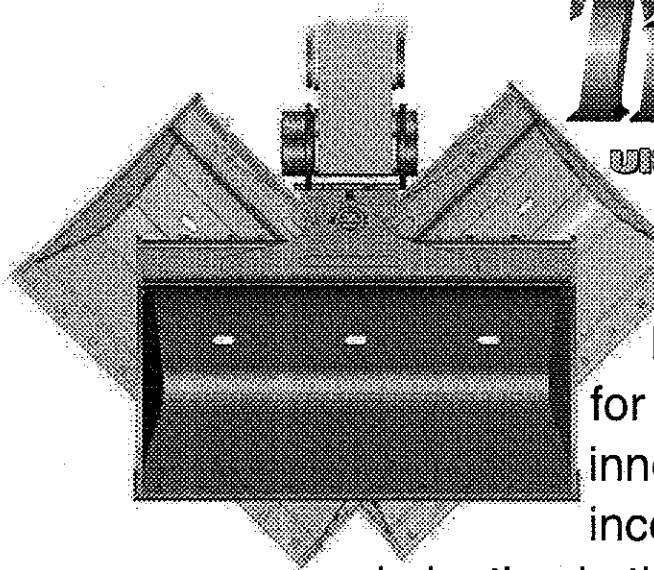

The Amulet Tilt Bucket is fast becoming standard equipment for many excavator operators. Our innovative and superior design incorporates every feature possible, culminating in the ultimate shaping tool.

Features and benefits of Amulet Tilt Buckets:

- Buckets tilt 45 degrees each way giving a full 90 degree range of tilt.
- Standard side taper allows for bucket clearance through crowd action.
- Heavy duty double-acting hydraulic cylinders are fully guarded.
- Induction hardened pivot pins mounted through large bushed surfaces maximize wearability.
- Cylinder rod ends are bushed for ease of maintenance.
- Hydraulic hose guides are provided for short hose protection.
- Twin cylinders come complete with bucket hose kit.
- Wear strips are fitted as standard features for extended bucket life.
- Bolt-on cutting edges can be fitted as an option increasing life of the base edge.
- Optional abrasion resistant side cutters and heavy duty cutting edge increases bucket rigidity, durability and wear.

*Perfect for
V-Ditching &
Sloping*

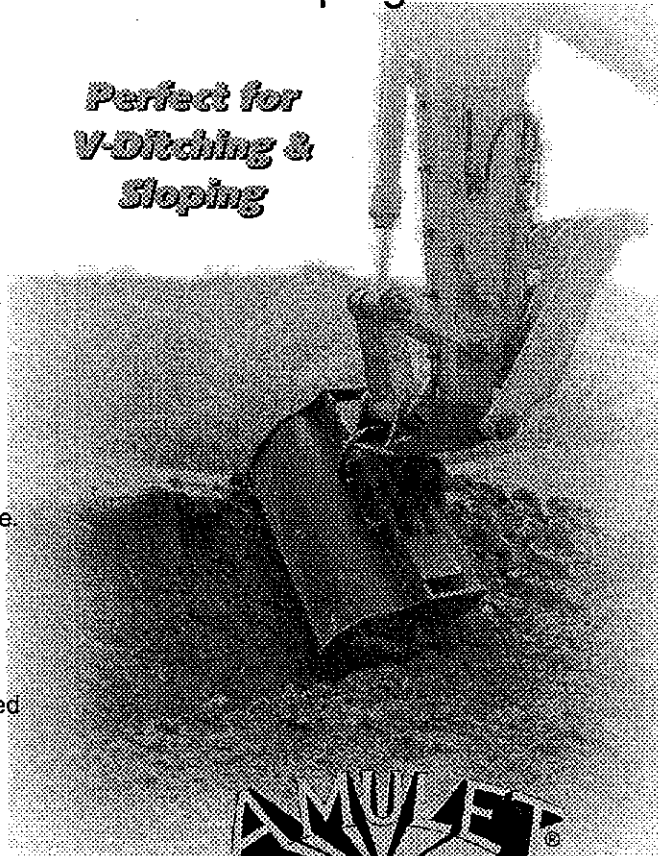

5640 West End Road • Arcata, CA 95521

Phone (707) 822-2282 • Fax 822-2398

Toll Free 800-526-8538

Visit Our Internet Web Site at amulet.com

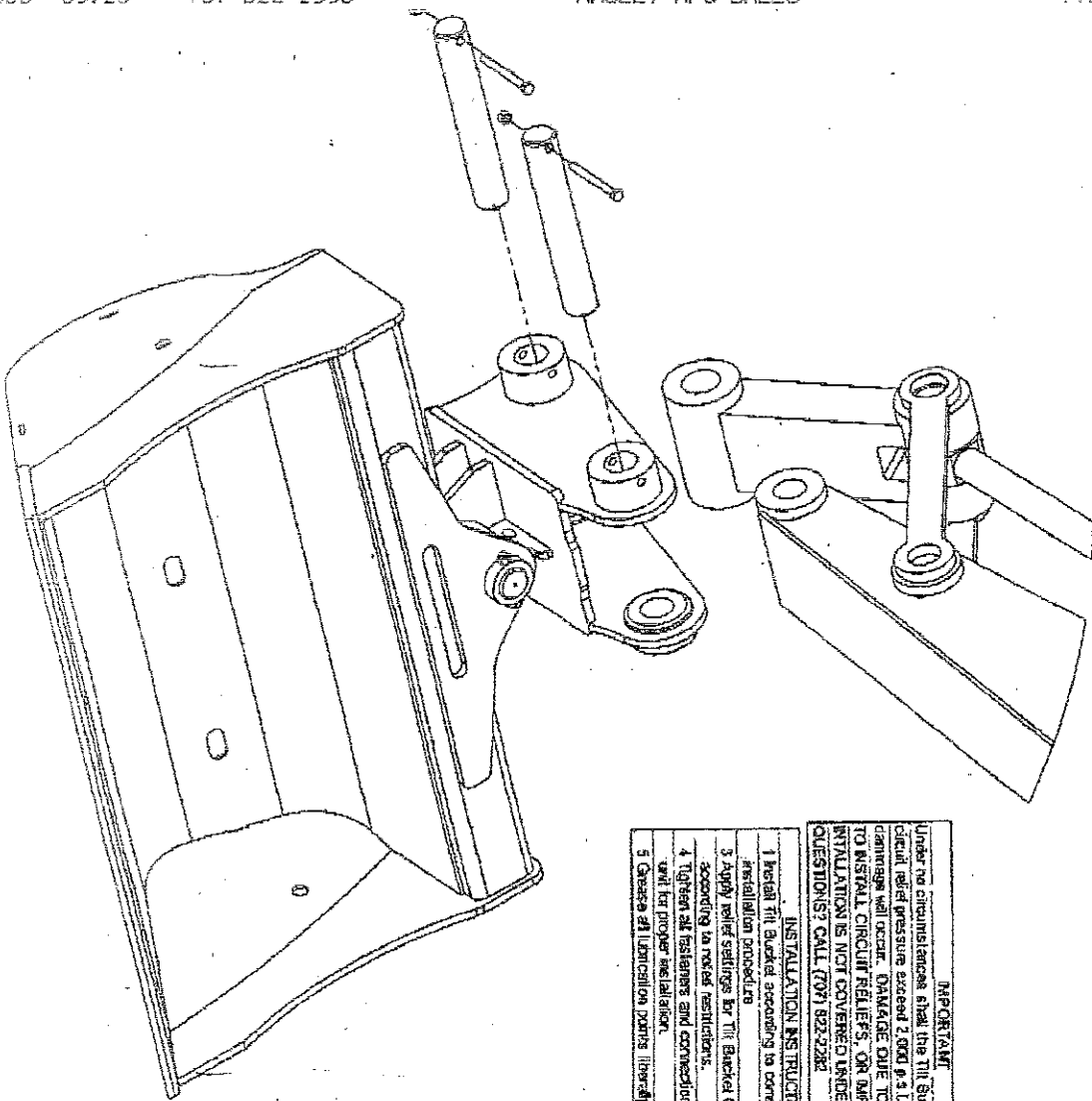

IMPORTANT
 Under no circumstances shall the Tilt Bucket Cylinder exceed relief pressure except 2,000 p.s.i. or changes will occur. DAMAGE DUE TO THE FAILURE TO INSTALL CIRCUIT RELIEFS, OR IMPROPER INSTALLATION IS NOT COVERED UNDER WARRANTY! QUESTIONS? CALL (707) 822-2282

INSTALLATION INSTRUCTIONS
 1. Install Tilt Bucket according to Operator Bucket Installation procedure
 2. Apply relief settings for Tilt Bucket Cylinders according to relief instructions.
 3. Tighten all fasteners and connections and inspect unit for proper installation.
 4. Grease all lubrication points liberally.

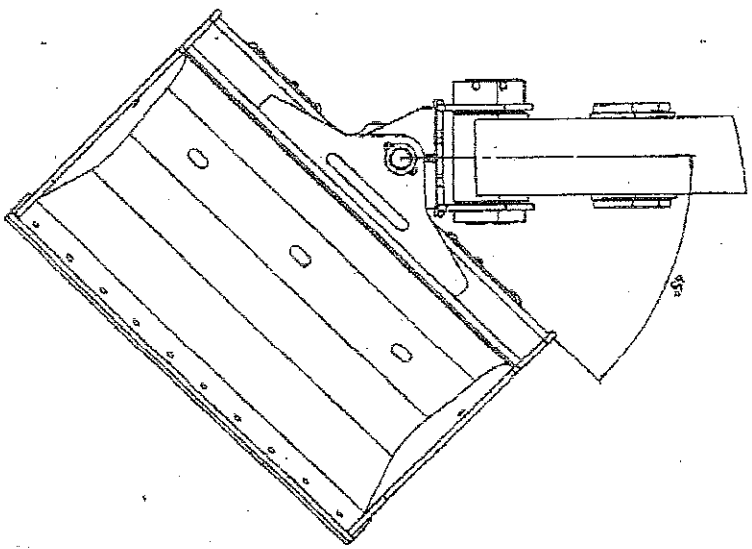

**TILT BUCKET
 INSTALLATION**

Diagram: IT2-1

AMULET MANUFACTURING CO., INC.
 5649 West End Road, Arcata, California 95521

| | | | | |
|--------|-------|-----|-----|----------|
| DES | IPD | CHK | DRN | DATE |
| | | | | 02/23/06 |
| SCALE | SHEET | NOV | | |
| 1 OF 1 | | | | |

STATE OF WEST VIRGINIA
Purchasing Division

PURCHASING AFFIDAVIT

West Virginia Code §5A-3-10a states: No contract or renewal of any contract may be awarded by the state or any of its political subdivisions to any vendor or prospective vendor when the vendor or prospective vendor or a related party to the vendor or prospective vendor is a debtor and the debt owed is an amount greater than one thousand dollars in the aggregate

DEFINITIONS:

"Debt" means any assessment, premium, penalty, fine, tax or other amount of money owed to the state or any of its political subdivisions because of a judgment, fine, permit violation, license assessment, defaulted workers' compensation premium, penalty or other assessment presently delinquent or due and required to be paid to the state or any of its political subdivisions, including any interest or additional penalties accrued thereon.

"Debtor" means any individual, corporation, partnership, association, limited liability company or any other form or business association owing a debt to the state or any of its political subdivisions. "Political subdivision" means any county commission; municipality; county board of education; any instrumentality established by a county or municipality; any separate corporation or instrumentality established by one or more counties or municipalities, as permitted by law; or any public body charged by law with the performance of a government function or whose jurisdiction is coextensive with one or more counties or municipalities. "Related party" means a party, whether an individual, corporation, partnership, association, limited liability company or any other form or business association or other entity whatsoever, related to any vendor by blood, marriage, ownership or contract through which the party has a relationship of ownership or other interest with the vendor so that the party will actually or by effect receive or control a portion of the benefit, profit or other consideration from performance of a vendor contract with the party receiving an amount that meets or exceed five percent of the total contract amount.

EXCEPTION: The prohibition of this section does not apply where a vendor has contested any tax administered pursuant to chapter eleven of this code, workers' compensation premium, permit fee or environmental fee or assessment and the matter has not become final or where the vendor has entered into a payment plan or agreement and the vendor is not in default of any of the provisions of such plan or agreement.

LICENSING: Vendors must be licensed and in good standing in accordance with any and all state and local laws and requirements by any state or local agency of West Virginia, including, but not limited to, the West Virginia Secretary of State's Office, the West Virginia Tax Department, West Virginia Insurance Commission, or any other state agencies or political subdivision. Furthermore, the vendor must provide all necessary releases to obtain information to enable the Director or spending unit to verify that the vendor is licensed and in good standing with the above entities.

CONFIDENTIALITY: The vendor agrees that he or she will not disclose to anyone, directly or indirectly, any such personally identifiable information or other confidential information gained from the agency, unless the individual who is the subject of the information consents to the disclosure in writing or the disclosure is made pursuant to the agency's policies, procedures and rules. Vendors should visit www.state.wv.us/admin/purchase/privacy for the Notice of Agency Confidentiality Policies.

Under penalty of law for false swearing (West Virginia Code, §61-5-3), it is hereby certified that the vendor acknowledges the information in this said affidavit and are in compliance with the requirements as stated.

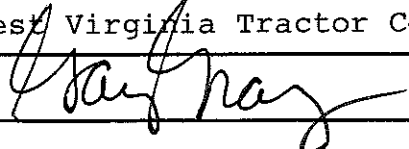
Vendor's Name: West Virginia Tractor Company
 Authorized Signature:  Date: 9/14/07