



State of West Virginia  
 Department of Administration  
 Purchasing Division  
 2019 Washington Street East  
 Post Office Box 50130  
 Charleston, WV 25305-0130

# Request for Quotation

RFQ NUMBER  
**0880175**

PAGE  
**1**

ADDRESS CORRESPONDENCE TO ATTENTION OF  
**MICHAEL AUSTIN**  
**304-558-2402**

**\*709060129**      **304-766-6601**  
**CHARLESTON STEEL**  
**PO BOX 547 511 28TH STREET**  
**DUNBAR WV 25064**

**DIVISION OF HIGHWAYS**  
**DISTRICT EIGHT**  
**P.O. BOX 1516**  
**US 219, NORTH PARSONS ROAD**  
**ELKINS, WV**  
**26241-1516**      **304-557-0215**

*Q 08-086*

DATE PRINTED <b>03/17/2008</b>	TERMS OF SALE <b>NET 30</b>	SHIP VIA <b>MOTOR FRT</b>	F.O.B. <b>ELKINS</b>	FREIGHT TERMS <b>INCL</b>
BID OPENING DATE: <b>04/02/2008</b>		BID OPENING TIME <b>01:30PM</b>		

LINE	QUANTITY	UOP	CAT NO.	ITEM NUMBER	UNIT PRICE	AMOUNT
0001	1	LB		570-84		32,212.66
<b>GALVANIZED STRUCTURAL STEEL</b>  <b>MATERIALS TO BE USED TO RENOVATE BEAVER LOOP BRIDGE PER THE ATTACHED SPECIFICATIONS.</b>  <b>PROJECT S338-21/1-0.07.</b>  <b>VENDOR PREFERENCE CERTIFICATE</b>  <b>CERTIFICATION AND APPLICATION* IS HEREBY MADE FOR PREFERENCE IN ACCORDANCE WITH WEST VIRGINIA CODE, 5A-3-37 (DOES NOT APPLY TO CONSTRUCTION CONTRACTS).</b>  <b>A. APPLICATION IS MADE FOR 2.5% PREFERENCE FOR THE REASON CHECKED:</b>  <input type="checkbox"/> <b>BIDDER IS AN INDIVIDUAL RESIDENT VENDOR AND HAS RESIDED CONTINUOUSLY IN WEST VIRGINIA FOR FOUR (4) YEARS IMMEDIATELY PRECEDING THE DATE OF THIS CERTIFICATION; OR</b>  <input checked="" type="checkbox"/> <b>BIDDER IS A PARTNERSHIP, ASSOCIATION OR CORPORATION RESIDENT VENDOR AND HAS MAINTAINED ITS HEAD-QUARTERS OR PRINCIPAL PLACE OF BUSINESS CONTINUOUSLY IN WEST VIRGINIA FOR FOUR (4) YEARS IMMEDIATELY PRECEDING THE DATE OF THIS CERTIFICATION; OR 80% OF THE OWNERSHIP INTEREST OF BIDDER IS HELD BY ANOTHER INDIVIDUAL, PARTNERSHIP, ASSOCIATION OR CORPORATION RESIDENT VENDOR WHO HAS MAINTAINED ITS HEADQUARTERS OR PRINCIPAL PLACE OF BUSINESS CONTINUOUSLY IN WEST VIRGINIA FOR FOUR (4) YEARS IMMEDIATELY PRECEDING THE DATE OF THIS</b>						

**RECEIVED**  
**2008 APR -2 A 9 40**  
**PURCHASING DIVISION**  
**STATE OF WV**

SEE REVERSE SIDE FOR TERMS AND CONDITIONS

SIGNATURE: *Remond Nicholas*      TELEPHONE: **304-766-6607**      DATE: **3/31/08**

TITLE: *Sala*      FEIN: **20-5496272**      ADDRESS CHANGES TO BE NOTED ABOVE

WHEN RESPONDING TO RFQ, INSERT NAME AND ADDRESS IN SPACE ABOVE LABELED 'VENDOR'

**GENERAL TERMS & CONDITIONS  
REQUEST FOR QUOTATION (RFQ) AND REQUEST FOR PROPOSAL (RFP)**

1. Awards will be made in the best interest of the State of West Virginia.
2. The State may accept or reject in part, or in whole, any bid.
3. All quotations are governed by the *West Virginia Code* and the *Legislative Rules* of the Purchasing Division.
4. Prior to any award, the apparent successful vendor must be properly registered with the Purchasing Division and have paid the required \$125.00 registration fee.
5. All services performed or goods delivered under State Purchase Orders/Contracts are to be continued for the term of the Purchase Order/Contract, contingent upon funds being appropriated by the Legislature or otherwise being made available. In the event funds are not appropriated or otherwise available for these services or goods, this Purchase Order/Contract becomes void and of no effect after June 30.
6. Payment may only be made after the delivery and acceptance of goods or services.
7. Interest may be paid for late payment in accordance with the *West Virginia Code*.
8. Vendor preference will be granted upon written request in accordance with the *West Virginia Code*.
9. The State of West Virginia is exempt from federal and state taxes and will not pay or reimburse such taxes.
10. The Director of Purchasing may cancel any Purchase Order/Contract upon 30 days written notice to the seller.
11. The laws of the State of West Virginia and the *Legislative Rules* of the Purchasing Division shall govern all rights and duties under the Contract, including without limitation the validity of this Purchase Order/Contract.
12. Any reference to automatic renewal is hereby deleted. The Contract may be renewed only upon mutual written agreement of the parties.
13. **BANKRUPTCY:** In the event the vendor/contractor files for bankruptcy protection, this Contract may be deemed null and void, and terminated without further order.
14. **HIPAA Business Associate Addendum** - The West Virginia State Government HIPAA Business Associate Addendum (BAA), approved by the Attorney General, and available online at the Purchasing Division's web site (<http://www.state.wv.us/admin/purchase/vrc/hipaa.htm>) is hereby made part of the agreement. Provided that, the Agency meets the definition of a Covered Entity (45 CFR §160.103) and will be disclosing Protected Health Information (45 CFR §160.103) to the vendor.

---

**INSTRUCTIONS TO BIDDERS**

1. Use the quotation forms provided by the Purchasing Division.
2. **SPECIFICATIONS:** Items offered must be in compliance with the specifications. Any deviation from the specifications must be clearly indicated by the bidder. Alternates offered by the bidder as **EQUAL** to the specifications must be clearly defined. A bidder offering an alternate should attach complete specifications and literature to the bid. The Purchasing Division may waive minor deviations to specifications.
3. Complete all sections of the quotation form.
4. Unit prices shall prevail in cases of discrepancy.
5. All quotations are considered F.O.B. destination unless alternate shipping terms are clearly identified in the quotation.
6. **BID SUBMISSION:** All quotations must be delivered by the bidder to the office listed below prior to the date and time of the bid opening. Failure of the bidder to deliver the quotations on time will result in bid disqualifications.

**SIGNED BID TO:**

Department of Administration  
Purchasing Division  
2019 Washington Street East  
Post Office Box 50130  
Charleston, WV 25305-0130



State of West Virginia  
 Department of Administration  
 Purchasing Division  
 2019 Washington Street East  
 Post Office Box 50130  
 Charleston, WV 25305-0130

# Request for Quotation

RFQ NUMBER  
**0880175**

PAGE  
**2**

ADDRESS CORRESPONDENCE TO ATTENTION OF  
**MICHAEL AUSTIN**  
**304-558-2402**

PURCHASER

\*709060129      304-766-6601  
**CHARLESTON STEEL**  
**PO BOX 547 511 28TH STREET**  
  
**DUNBAR WV 25064**

SHIP TO

**DIVISION OF HIGHWAYS**  
**DISTRICT EIGHT**  
**P.O. BOX 1516**  
**US 219, NORTH PARSONS ROAD**  
**ELKINS, WV**  
**26241-1516      304-557-0215**

DATE PRINTED	TERMS OF SALE	SHIP VIA	F.O.B.	FREIGHT TERMS
03/17/2008	NET 30	MOTOR FDS	ELKINS	INCL
BID OPENING DATE: 04/02/2008		BID OPENING TIME 01:30PM		

LINE	QUANTITY	UOP	CAT NO	ITEM NUMBER	UNIT PRICE	AMOUNT
<p>CERTIFICATION; OR</p> <p>( ) BIDDER IS A CORPORATION NONRESIDENT VENDOR WHICH HAS AN AFFILIATE OR SUBSIDIARY WHICH EMPLOYS A MINIMUM OF ONE HUNDRED STATE RESIDENTS AND WHICH HAS MAINTAINED ITS HEADQUARTERS OR PRINCIPAL PLACE OF BUSINESS WITHIN WEST VIRGINIA CONTINUOUSLY FOR THE FOUR (4) YEARS IMMEDIATELY PRECEDING THE DATE OF THIS CERTIFICATION.</p> <p>B. APPLICATION IS MADE FOR 2.5% PREFERENCE FOR THE REASON CHECKED:</p> <p>(✓) BIDDER IS A RESIDENT VENDOR WHO CERTIFIES THAT, DURING THE LIFE OF THE CONTRACT, ON AVERAGE AT LEAST 75% OF THE EMPLOYEES WORKING ON THE PROJECT BEING BID ARE RESIDENTS OF WEST VIRGINIA WHO HAVE RESIDED IN THE STATE CONTINUOUSLY FOR THE TWO YEARS IMMEDIATELY PRECEDING SUBMISSION OF THIS BID;</p> <p>OR</p> <p>( ) BIDDER IS A NONRESIDENT VENDOR EMPLOYING A MINIMUM OF ONE HUNDRED STATE RESIDENTS OR IS A NONRESIDENT VENDOR WITH AN AFFILIATE OR SUBSIDIARY WHICH MAINTAINS ITS HEADQUARTERS OR PRINCIPAL PLACE OF BUSINESS WITHIN WEST VIRGINIA EMPLOYING A MINIMUM OF ONE HUNDRED STATE RESIDENTS WHO CERTIFIES THAT, DURING THE LIFE OF THE CONTRACT, ON AVERAGE AT LEAST 75% OF THE EMPLOYEES OR BIDDERS' AFFILIATE'S OR SUBSIDIARY'S EMPLOYEES ARE RESIDENTS OF WEST VIRGINIA WHO HAVE RESIDED IN THE STATE CONTINUOUSLY FOR THE TWO YEARS IMMEDIATELY PRECEDING SUBMISSION OF THIS BID.</p> <p>BIDDER UNDERSTANDS IF THE SECRETARY OF TAX &amp; REVENUE DETERMINES THAT A BIDDER RECEIVING PREFERENCE HAS FAILED TO CONTINUE TO MEET THE REQUIREMENTS FOR SUCH PREFERENCE, THE SECRETARY MAY ORDER THE DIRECTOR OF</p>						

SEE REVERSE SIDE FOR TERMS AND CONDITIONS

SIGNATURE <i>Demetrius Luchala</i>	TELEPHONE 304-766-6607	DATE 3/31/08
TITLE <i>Sales</i>	FEIN 20-5496272	ADDRESS CHANGES TO BE NOTED ABOVE

WHEN RESPONDING TO RFQ, INSERT NAME AND ADDRESS IN SPACE ABOVE LABELED 'VENDOR'



State of West Virginia  
 Department of Administration  
 Purchasing Division  
 2019 Washington Street East  
 Post Office Box 50130  
 Charleston, WV 25305-0130

# Request for Quotation

RFO NUMBER  
**0880175**

PAGE  
**3**

ADDRESS CORRESPONDENCE TO ATTENTION OF  
**MICHAEL AUSTIN  
 304-558-2402**

**\*709060129      304-766-6601**  
**CHARLESTON STEEL**  
**PO BOX 547 511 28TH STREET**  
**DUNBAR WV 25064**

**DIVISION OF HIGHWAYS**  
**DISTRICT EIGHT**  
**P.O. BOX 1516**  
**US 219, NORTH PARSONS ROAD**  
**ELKINS, WV**  
**26241-1516      304-557-0215**

DATE PRINTED <b>03/17/2008</b>	TERMS OF SALE <b>NET 30</b>	SHIP VIA <b>MOTOR FLT</b>	F.O.B. <b>ELKINS</b>	FREIGHT TERMS <b>INCL</b>
BID OPENING DATE: <b>04/02/2008</b>		BID OPENING TIME <b>01:30PM</b>		

LINE	QUANTITY	UOP	CAT NO	ITEM NUMBER	UNIT PRICE	AMOUNT
<p>PURCHASING TO: (A) RESCIND THE CONTRACT OR PURCHASE ORDER ISSUED; OR (B) ASSESS A PENALTY AGAINST SUCH BIDDER IN AN AMOUNT NOT TO EXCEED 5% OF THE BID AMOUNT AND THAT SUCH PENALTY WILL BE PAID TO THE CONTRACTING AGENCY OR DEDUCTED FROM ANY UNPAID BALANCE ON THE CONTRACT OR PURCHASE ORDER.</p> <p>BY SUBMISSION OF THIS CERTIFICATE, BIDDER AGREES TO DISCLOSE ANY REASONABLY REQUESTED INFORMATION TO THE PURCHASING DIVISION AND AUTHORIZES THE DEPARTMENT OF TAX AND REVENUE TO DISCLOSE TO THE DIRECTOR OF PURCHASING APPROPRIATE INFORMATION VERIFYING THAT BIDDER HAS PAID THE REQUIRED BUSINESS TAXES, PROVIDED THAT SUCH INFORMATION DOES NOT CONTAIN THE AMOUNTS OF TAXES PAID NOR ANY OTHER INFORMATION DEEMED BY THE TAX COMMISSIONER TO BE CONFIDENTIAL.</p> <p>UNDER PENALTY OF LAW FOR FALSE SWEARING (WEST VIRGINIA CODE 61-5-3), BIDDER HEREBY CERTIFIES THAT THIS CERTIFICATE IS TRUE AND ACCURATE IN ALL RESPECTS; AND THAT IF A CONTRACT IS ISSUED TO BIDDER AND IF ANYTHING CONTAINED WITHIN THIS CERTIFICATE CHANGES DURING THE TERM OF THE CONTRACT, BIDDER WILL NOTIFY THE PURCHASING DIVISION IN WRITING IMMEDIATELY.</p> <p>BIDDER: <u>CHARLESTON STEEL Co</u></p> <p>DATE: <u>3/31/08</u></p> <p>SIGNED: <u>[Signature]</u></p> <p>TITLE: <u>Sales</u></p>						

SEE REVERSE SIDE FOR TERMS AND CONDITIONS

SIGNATURE <u>[Signature]</u>	TELEPHONE <u>304-766-6607</u>	DATE <u>3/31/08</u>
TITLE <u>Sales</u>	FEIN <u>20-5496272</u>	ADDRESS CHANGES TO BE NOTED ABOVE

WHEN RESPONDING TO RFQ, INSERT NAME AND ADDRESS IN SPACE ABOVE LABELED 'VENDOR'



State of West Virginia  
 Department of Administration  
 Purchasing Division  
 2019 Washington Street East  
 Post Office Box 50130  
 Charleston, WV 25305-0130

# Request for Quotation

RFQ NUMBER  
**0880175**

PAGE  
**4**

ADDRESS CORRESPONDENCE TO ATTENTION OF:  
**MICHAEL AUSTIN**  
**304-558-2402**

**\*709060129 304-766-6601**  
**CHARLESTON STEEL**  
**PO BOX 547 511 28TH STREET**  
**DUNBAR WV 25064**

**DIVISION OF HIGHWAYS**  
**DISTRICT EIGHT**  
**P.O. BOX 1516**  
**US 219, NORTH PARSONS ROAD**  
**ELKINS, WV**  
**26241-1516 304-557-0215**

DATE PRINTED	TERMS OF SALE	SHIP VIA	F.O.B.	FREIGHT TERMS
03/17/2008	NET 30	MOBILE	ELKINS	INCL

BID OPENING DATE: **04/02/2008** BID OPENING TIME **01:30PM**

LINE	QUANTITY	UOP	CAT. NO.	ITEM NUMBER	UNIT PRICE	AMOUNT
<p>* CHECK ANY COMBINATION OF PREFERENCE CONSIDERATION(S) IN EITHER "A" OR "B", OR BOTH "A" AND "B" WHICH YOU ARE ENTITLED TO RECEIVE. YOU MAY REQUEST UP TO THE MAXIMUM 5% PREFERENCE FOR BOTH "A" AND "B". (REV. 12/00)</p> <p>NOTICE</p> <p>A SIGNED BID MUST BE SUBMITTED TO:</p> <p>DEPARTMENT OF ADMINISTRATION          PURCHASING DIVISION          BUILDING 15          2019 WASHINGTON STREET, EAST          CHARLESTON, WV 25305-0130</p> <p>THE BID SHOULD CONTAIN THIS INFORMATION ON THE FACE OF THE ENVELOPE OR THE BID MAY NOT BE CONSIDERED:</p> <p>SEALED BID</p> <p>BUYER: 33</p> <p>RFQ. NO.: 0880175</p> <p>BID OPENING DATE: 04/02/2008</p> <p>BID OPENING TIME: 1:30 PM</p> <p>PLEASE PROVIDE A FAX NUMBER IN CASE IT IS NECESSARY TO CONTACT YOU REGARDING YOUR BID:          ----- <b>304-766-6603</b> -----</p>						

SEE REVERSE SIDE FOR TERMS AND CONDITIONS

SIGNATURE <i>Dennis Dehaer</i>	TELEPHONE <b>304-766-6607</b>	DATE <b>3/31/08</b>
TITLE <i>Sales</i>	FEIN <b>20-5496272</b>	ADDRESS CHANGES TO BE NOTED ABOVE

WHEN RESPONDING TO RFQ, INSERT NAME AND ADDRESS IN SPACE ABOVE LABELED 'VENDOR'



State of West Virginia  
 Department of Administration  
 Purchasing Division  
 2019 Washington Street East  
 Post Office Box 50130  
 Charleston, WV 25305-0130

# Request for Quotation

RFQ NUMBER  
**0880175**

PAGE  
**5**

ADDRESS CORRESPONDENCE TO ATTENTION OF  
**MICHAEL AUSTIN**  
**304-558-2402**

**VENDOR**  
 \*709060129      304-766-6601  
**CHARLESTON STEEL**  
**PO BOX 547 511 28TH STREET**  
**DUNBAR WV 25064**

**SHIP TO**  
**DIVISION OF HIGHWAYS**  
**DISTRICT EIGHT**  
**P.O. BOX 1516**  
**US 219, NORTH PARSONS ROAD**  
**ELKINS, WV**  
**26241-1516      304-557-0215**

DATE PRINTED	TERMS OF SALE	SHIP VIA	F.O.B.	FREIGHT TERMS
03/17/2008	NET 30	MOTOR FLT	ELKINS	INCL
BID OPENING DATE: 04/02/2008		BID OPENING TIME 01:30PM		

LINE	QUANTITY	UOP	CAT NO.	ITEM NUMBER	UNIT PRICE	AMOUNT
CONTACT PERSON (PLEASE PRINT CLEARLY): <u>DENNIS NICHOLAS</u>						
***** THIS IS THE END OF RFQ 0880175 *****						TOTAL: <u>\$ 32,212.66</u>

SEE REVERSE SIDE FOR TERMS AND CONDITIONS

SIGNATURE <i>Dennis Nicholas</i>	TELEPHONE 304-766-6607	DATE 3/31/08
TITLE <i>Sales</i>	FEIN 20-5496272	ADDRESS CHANGES TO BE NOTED ABOVE

WHEN RESPONDING TO RFQ, INSERT NAME AND ADDRESS IN SPACE ABOVE LABELED 'VENDOR'

Item No.	Quantity	Description	Unit Price	Amount
1	11702.50	LB - W 21x62, Galvanized W-Shaped Structural Steel, AASHTO M270, Grade 50. Ship 5 pieces @ 37'-9"	<u>963</u>	<u>11,269.50</u>
2	1000.00	LB - C 12x25 Galvanized Structural Steel Channel, AASHTO M270, Grade 50. Ship 2 pieces @ 20'-0"	<u>937</u>	<u>937.00</u>
3	1379.20	LB - 6"x6"x1/2" (34.48#/LF) Galvanized Structural Steel Tubing, ASTM 500. Ship 2 pieces @ 20'-0"	<u>941</u>	<u>1297.83</u>
4	8568.00	LB - 3/4"x12" (30.6#/LF) Galvanized Structural Steel Plate, AASHTO M270, Grade 50. Ship 14 pieces @ 20'-0"	<u>1.01</u>	<u>8653.68</u>
5	640.00	LB - L 4"x4"x1/2" (12.8#/LF) Galvanized Structural Steel Angle, AASHTO M270, Grade 50. Ship 50 pieces @ 1'-0", Fabricated in accordance with sketch #1.	<u>1.78</u>	<u>1139.20</u>
6	4018.00	LB - L 6"x6"x3/4" (28.7#/LF) Galvanized Structural Steel Angle, AASHTO M270, Grade 50. Ship 7 pieces @ 20'-0"	<u>984</u>	<u>3953.71</u>
7	2592.00	LB - L 6"x4"x1/2" (16.2#/LF) Galvanized Structural Steel Angle, AASHTO M270, Grade 50. Ship 8 pieces @ 20'-0"	<u>974</u>	<u>2524.61</u>
8	2560.00	LB - L 4"x4"x1/2" (12.8#/LF) Galvanized Structural Steel Angle, AASHTO M270, Grade 50. Ship 10 pieces @ 20'-0"	<u>952</u>	<u>2437.12</u>
		TOTAL		<u>\$ 32,212.66</u> <u>32,212.66</u>

		Description		
		<p>Notes:</p> <ol style="list-style-type: none"><li>1. The above listed materials are to be delivered to the WVDOH, District Eight lot, located on US Route 219, approximately 1 mile North of Elkins, WV.</li><li>2. The District Eight Storekeeper must be notified at (304) 637-0226 at least 48 hours in advance of delivery to provide necessary personnel and equipment for unloading.</li><li>3. Delivery will only be accepted during normal working hours of 7:30am to 4:00pm, Monday – Friday.</li><li>4. Galvanizing shall be after fabrication and in accordance with AASHTO M111.</li><li>5. All materials shall be in accordance with the West Virginia Division of Highways, Standard Specification Roads and Bridges, Adopted 2000, and the current Supplemental Specifications.</li><li>6. AASHTO M270 shall have a toughness test in accordance with S-4, Non-Fracture-Critical, Zone 2.</li></ol>		



STATE OF WEST VIRGINIA  
Purchasing Division

## PURCHASING AFFIDAVIT

**West Virginia Code §5A-3-10a states:** No contract or renewal of any contract may be awarded by the state or any of its political subdivisions to any vendor or prospective vendor when the vendor or prospective vendor or a related party to the vendor or prospective vendor is a debtor and the debt owed is an amount greater than one thousand dollars in the aggregate

### DEFINITIONS:

"Debt" means any assessment, premium, penalty, fine, tax or other amount of money owed to the state or any of its political subdivisions because of a judgment, fine, permit violation, license assessment, defaulted workers' compensation premium, penalty or other assessment presently delinquent or due and required to be paid to the state or any of its political subdivisions, including any interest or additional penalties accrued thereon.

"Debtor" means any individual, corporation, partnership, association, limited liability company or any other form or business association owing a debt to the state or any of its political subdivisions. "Political subdivision" means any county commission; municipality; county board of education; any instrumentality established by a county or municipality; any separate corporation or instrumentality established by one or more counties or municipalities, as permitted by law; or any public body charged by law with the performance of a government function or whose jurisdiction is coextensive with one or more counties or municipalities. "Related party" means a party, whether an individual, corporation, partnership, association, limited liability company or any other form or business association or other entity whatsoever, related to any vendor by blood, marriage, ownership or contract through which the party has a relationship of ownership or other interest with the vendor so that the party will actually or by effect receive or control a portion of the benefit, profit or other consideration from performance of a vendor contract with the party receiving an amount that meets or exceed five percent of the total contract amount.

**EXCEPTION:** The prohibition of this section does not apply where a vendor has contested any tax administered pursuant to chapter eleven of this code, workers' compensation premium, permit fee or environmental fee or assessment and the matter has not become final or where the vendor has entered into a payment plan or agreement and the vendor is not in default of any of the provisions of such plan or agreement.

**LICENSING:** Vendors must be licensed and in good standing in accordance with any and all state and local laws and requirements by any state or local agency of West Virginia, including, but not limited to, the West Virginia Secretary of State's Office, the West Virginia Tax Department, West Virginia Insurance Commission, or any other state agencies or political subdivision. Furthermore, the vendor must provide all necessary releases to obtain information to enable the Director or spending unit to verify that the vendor is licensed and in good standing with the above entities.

**CONFIDENTIALITY:** The vendor agrees that he or she will not disclose to anyone, directly or indirectly, any such personally identifiable information or other confidential information gained from the agency, unless the individual who is the subject of the information consents to the disclosure in writing or the disclosure is made pursuant to the agency's policies, procedures and rules. Vendors should visit [www.state.wv.us/admin/purchase/privacy](http://www.state.wv.us/admin/purchase/privacy) for the Notice of Agency Confidentiality Policies.

Under penalty of law for false swearing (West Virginia Code, §61-5-3), it is hereby certified that the vendor acknowledges the information in this said affidavit and are in compliance with the requirements as stated.

Vendor's Name: CHARLESTON STEEL Co

Authorized Signature: Dennis Nicholas

Date: 3/31/08

W. Va. Department of Transportation  
Division of Highways, District 8  
PO Box 1516  
Elkins, WV 26241  
RPO No. 088-0175  
Page No. 4 of 4  
Sketch No. 1

ALL HOLES  $1\frac{3}{16}$ " DIAMETER

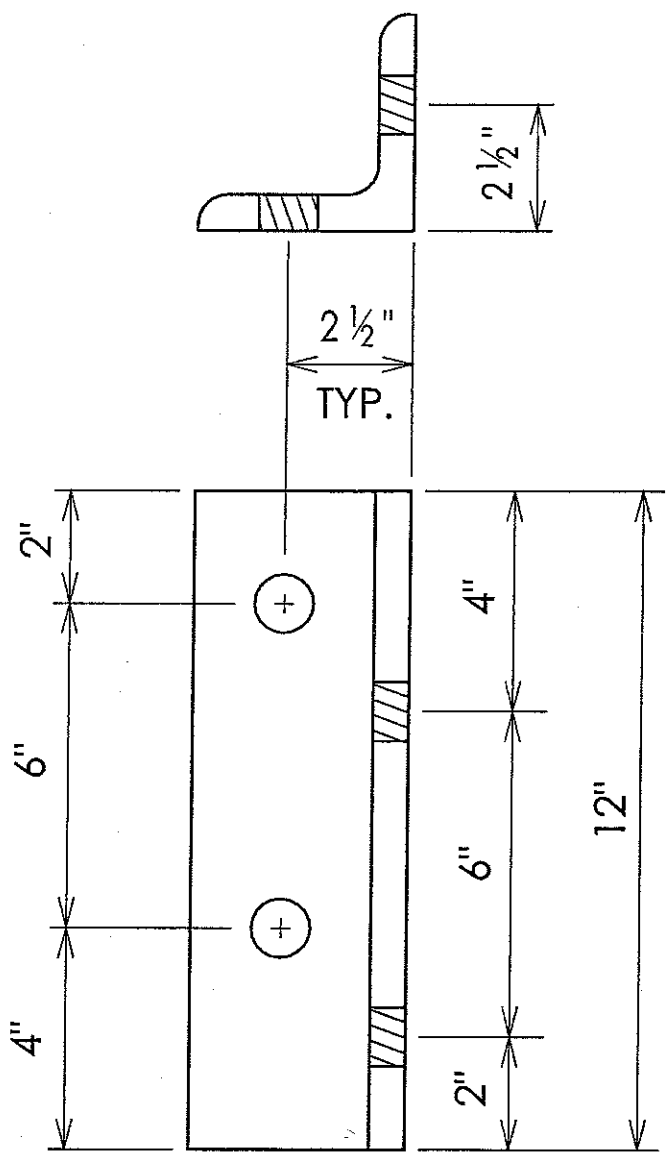

CLIP ANGLE

ANGLE 4"x4"x  $\frac{1}{2}$ " - 50 REQUIRED