



State of West Virginia  
 Department of Administration  
 Purchasing Division  
 2019 Washington Street East  
 Post Office Box 50130  
 Charleston, WV 25305-0130

**Request for Quotation**

RFQ NUMBER: WEH60241

PAGE: 1

ADDRESS CORRESPONDENCE TO ATTENTION OF:  
 ROBERTA WAGNER  
 304-558-0067

RFQ COPY  
 TYPE NAME/ADDRESS HERE

VENDOR

Murphy Sheet Metal Co. Inc.  
 3112 Seventh Street  
 Parkersburg, WV 26104  
 304-422-5431

SHIP TO

HEALTH AND HUMAN RESOURCES  
 WELCH COMMUNITY HOSPITAL

454 MCDOWELL STREET  
 WELCH, WV 24801 304-436-8710

DATE PRINTED 06/21/2006	TERMS OF SALE	SHIP VIA	FOB	FREIGHT TERMS
BID OPENING DATE: 07/05/2006		BID OPENING TIME 01:30PM		

LINE	QUANTITY	UOP	CAT NO	ITEM NUMBER	UNIT PRICE	AMOUNT
<p>*****ADDENDUM NO. 1*****</p> <p>1. QUESTION: IS THERE ANY REASON WHY A PACKAGED UNIT CANNOT BE USED TO REPLACE THE EXISTING SPLIT SYSTEM?</p> <p>ANSWER: NO. THERE IS NO PROBLEM WITH USING A PACKAGE UNIT.</p> <p>2. ADDENDUM ACKNOWLEDGEMENT IS ATTACHED. THIS DOCUMENT SHOULD BE SIGNED AND RETURNED WITH YOUR BID. FAILURE TO SIGN AND RETURN MAY RESULT IN DISQUALIFICATION OF YOUR BID.</p> <p>*****END OF ADDENDUM NO. 1*****</p>						

SEE REVERSE SIDE FOR TERMS AND CONDITIONS

SIGNATURE	TELEPHONE	DATE
TITLE	FEIN	ADDRESS CHANGES TO BE NOTED ABOVE

WHEN RESPONDING TO RFQ, INSERT NAME AND ADDRESS IN SPACE ABOVE LABELED 'VENDOR'

WV-36a <b>STATE OF WEST VIRGINIA PURCHASING CONTINUATION SHEET</b>	Buyer:	Page	Req. or P. O. No.:
Vendor:	Spending Unit:		

Requisition No.: WEH60241

**ADDENDUM ACKNOWLEDGEMENT**

I hereby acknowledge receipt of the following checked addendum(s) and have made the necessary revisions to my proposal, plans and/or specifications, etc.

**Addendum No.'s:**

No. 1  \_\_\_\_\_

No. 2 \_\_\_\_\_

No. 3 \_\_\_\_\_

No. 4 \_\_\_\_\_

No. 5 \_\_\_\_\_

I understand that failure to confirm the receipt of the addendum(s) is cause for rejection of bids.

*Andy Moore*  
Signature

Murray Sheet Metal Co. Inc.  
Company

June 27, 2006  
Date



State of West Virginia  
 Department of Administration  
 Purchasing Division  
 2019 Washington Street East  
 Post Office Box 50130  
 Charleston, WV 25305-0130

# Request for Quotation

RFQ NUMBER  
**WEH60241**

PAGE  
**1**

ADDRESS CORRESPONDENCE TO ATTENTION OF:  
**ROBERTA WAGNER**  
**304-558-0067**

VENDOR

RFQ COPY  
 TYPE NAME/ADDRESS HERE  
*Murray Sheet Metal corpe*  
*3112 Seventh Street*  
*Parkersburg, WV 26104*  
*304-422-5431*

SHIP TO

HEALTH AND HUMAN RESOURCES  
 WELCH COMMUNITY HOSPITAL  
  
 454 MCDOWELL STREET  
 WELCH, WV  
 24801 304-436-8710

DATE PRINTED	TERMS OF SALE	SHIP VIA	F.O.B.	FREIGHT TERMS
05/18/2006				

BID OPENING DATE: **07/05/2006** BID OPENING TIME **01:30PM**

LINE	QUANTITY	UOP	CAT. NO.	ITEM NUMBER	UNIT PRICE	AMOUNT
*****REQUEST FOR QUOTATION*****  THE WEST VIRGINIA DIVISION OF PURCHASING IS SOLICITING BIDS FOR WELCH COMMUNITY HOSPITAL TO PROVIDE ALL LABOR, MATERIALS, EQUIPMENT AND ANY OTHER REPAIRS OR ALTERATIONS REQUIRED FOR THE REMOVAL OF THE EXISTING MCQUAY CORPORATION AIR HANDLING UNIT AND REPLACE WITH TRANE OR EQUAL, OR GREATER SIZE, AIR COOLED CONDENSING UNIT.  PLEASE NOTE THAT THERE IS A MANDATORY ON-SITE PRE-BID MEETING ON JUNE 13, 2006 AT 11:00 AM. SAID CONFERENCE WILL TAKE PLACE AT WELCH COMMUNITY HOSPITAL, 454 MCDOWELL STREET, WELCH, WV 24801. ALL INTERESTED BIDDERS ARE REQUIRED TO BE PRESENT AT THIS MEETING. FAILURE TO ATTEND THE MANDATORY PRE-BID CONFERENCE SHALL AUTOMATICALLY RESULT IN DISQUALIFICATION. NO ONE CAN REPRESENT MORE THAN ONE VENDOR. *****  SCHEDULE OF EVENTS: RELEASE OF THE RFQ.....MAY 26, 2006 VENDOR'S WRITTEN QUESTIONS SUBMISSION DEADLINE: (CLOSE OF BUSINESS).....JUNE 9, 2006 MANDATORY ON-SITE PRE-BID CONFERENCE.....JUNE 13, 2006 ADDENDUM ISSUED.....JUNE 20, 2006 BID OPENING DATE.....JULY 5, 2006  PLEASE NOTE THE FOLLOWING ATTACHMENTS: 1) WEH60241 SPECIFICATIONS 2) AFFIDAVIT						
SEE REVERSE SIDE FOR TERMS AND CONDITIONS						

SIGNATURE		TELEPHONE	DATE
TITLE	FEIN	ADDRESS CHANGES TO BE NOTED ABOVE	

WHEN RESPONDING TO RFQ, INSERT NAME AND ADDRESS IN SPACE ABOVE LABELED 'VENDOR'

**GENERAL TERMS & CONDITIONS  
REQUEST FOR QUOTATION (RFQ) AND REQUEST FOR PROPOSAL (RFP)**

1. Awards will be made in the best interest of the State of West Virginia.
2. The State may accept or reject in part, or in whole, any bid.
3. All quotations are governed by the *West Virginia Code* and the *Legislative Rules* of the Purchasing Division.
4. Prior to any award, the apparent successful vendor must be properly registered with the Purchasing Division and have paid the required registration fee. (Effective June 8, 2006, the fee will change from \$45.00 to \$125.00 pursuant to House Bill 4031.)
5. All services performed or goods delivered under State Purchase Orders/Contracts are to be continued for the term of the Purchase Order/Contract, contingent upon funds being appropriated by the Legislature or otherwise being made available. In the event funds are not appropriated or otherwise available for these services or goods, this Purchase Order/Contract becomes void and of no effect after June 30.
6. Payment may only be made after the delivery and acceptance of goods or services.
7. Interest may be paid for late payment in accordance with the *West Virginia Code*.
8. Vendor preference will be granted upon written request in accordance with the *West Virginia Code*.
9. The State of West Virginia is exempt from federal and state taxes and will not pay or reimburse such taxes.
10. The Director of Purchasing may cancel any Purchase Order/Contract upon 30 days written notice to the seller.
11. The laws of the State of West Virginia and the *Legislative Rules* of the Purchasing Division shall govern all rights and duties under the Contract, including without limitation the validity of this Purchase Order/Contract.
12. Any reference to automatic renewal is hereby deleted. The Contract may be renewed only upon mutual written agreement of the parties.
13. **BANKRUPTCY:** In the event the vendor/contractor files for bankruptcy protection, this contract is automatically null and void, and is terminated without further order.
14. **HIPAA Business Associate Addendum -** The West Virginia State Government HIPAA Business Associate Addendum (BAA), approved by the Attorney General, and available online at the Purchasing Division's web site (<http://www.state.wv.us/admin/purchase/vrc/hipaa.htm>) is hereby made part of the agreement. Provided that, the Agency meets the definition of a Covered Entity (45 CFR §160.103) and will be disclosing Protected Health Information (45 CFR §160.103) to the vendor.

---

**INSTRUCTIONS TO BIDDERS**

1. Use the quotation forms provided by the Purchasing Division.
2. **SPECIFICATIONS:** Items offered must be in compliance with the specifications. Any deviation from the specifications must be clearly indicated by the bidder. Alternates offered by the bidder as **EQUAL** to the specifications must be clearly defined. A bidder offering an alternate should attach complete specifications and literature to the bid. The Purchasing Division may waive minor deviations to specifications.
3. Complete all sections of the quotation form.
4. Unit prices shall prevail in cases of discrepancy.
5. All quotations are considered F.O.B. destination unless alternate shipping terms are clearly identified in the quotation.
6. **DUPLICATE BIDS:** All quotations must be delivered by the bidder to the respective offices listed below prior to the date and time of the bid opening. Failure of the bidder to deliver the quotations on time will result in bid disqualifications.

**ORIGINAL SIGNED BID TO:**

Department of Administration  
Purchasing Division  
2019 Washington Street East  
Post Office Box 50130  
Charleston, WV 25305-0130

**DUPLICATE BID TO:**

State Auditor's Office  
Bid Observer  
Building 1 Room W114  
1900 Kanawha Boulevard, East  
Charleston, WV 25305-0230

NOTICE: Beginning June 8, 2006, there is no need to submit a duplicate bid to the State Auditor's Office pursuant to House Bill 4031.



State of West Virginia  
 Department of Administration  
 Purchasing Division  
 2019 Washington Street East  
 Post Office Box 50130  
 Charleston, WV 25305-0130

# Request for Quotation

RFQ NUMBER
WEH60241

PAGE
2

ADDRESS CORRESPONDENCE TO ATTENTION OF
ROBERTA WAGNER 304-558-0067

VENDOR

RFQ COPY  
 TYPE NAME/ADDRESS HERE

SHIP TO

HEALTH AND HUMAN RESOURCES  
 WELCH COMMUNITY HOSPITAL  
  
 454 MCDOWELL STREET  
 WELCH, WV  
 24801 304-436-8710

DATE PRINTED	TERMS OF SALE	SHIP VIA	F.O.B.	FREIGHT TERMS
05/18/2006				

BID OPENING DATE: 07/05/2006 BID OPENING TIME 01:30PM

LINE	QUANTITY	UOP	CAT. NO.	ITEM NUMBER	UNIT PRICE	AMOUNT
0001	1	JB		936-10		
<p>REPLACE HEATING, VENTILATING AND COOLING (HVAC) SYS.</p> <p>REQUEST FOR QUOTATION</p> <p>TO PROVIDE ALL LABOR, MATERIAL, EQUIPMENT, AND ANYTHING INCIDENTAL TO THE PROVISION AND INSTALLATION OF HEATING, VENTILATING AND COOLING (HVAC) COMPONENTS AND OTHER CERTAIN RENOVATIONS AS LISTED HEREIN FOR THE WELCH COMMUNITY HOSPITAL LOCATED AT 454 MCDOWELL STREET, WELCH, WEST VIRGINIA 24801, AS PER THE ATTACHED SPECIFICATIONS.</p> <p>A MANDATORY VENDOR PREBID CONFERENCE WILL BE HELD ON JUNE 13, 2006 AT 11:00 AM AT THE HOSPITAL. FAILURE TO ATTEND THE MANDATORY PRE-BID CONFERENCE SHALL RESULT IN BID DISQUALIFICATION.</p> <p>EXHIBIT 5</p> <p>NOTICE TO PROCEED: THIS CONTRACT IS TO BE PERFORMED WITHIN 120 CALENDAR DAYS AFTER THE NOTICE TO PROCEED IS RECEIVED. UNLESS OTHERWISE SPECIFIED, THE FULLY EXECUTED PURCHASE ORDER WILL BE CONSIDERED NOTICE TO PROCEED.</p> <p>CANCELLATION: THE DIRECTOR OF PURCHASING RESERVES THE RIGHT TO CANCEL THIS CONTRACT IMMEDIATELY UPON WRITTEN NOTICE TO THE VENDOR IF THE MATERIALS OR WORKMANSHIP SUPPLIED ARE OF AN INFERIOR QUALITY OR DO NOT CONFORM WITH THE SPECIFICATIONS OF THE BID AND CONTRACT HERE IN.</p>						

SEE REVERSE SIDE FOR TERMS AND CONDITIONS

SIGNATURE	TELEPHONE	DATE
TITLE	FEIN	ADDRESS CHANGES TO BE NOTED ABOVE

WHEN RESPONDING TO RFQ, INSERT NAME AND ADDRESS IN SPACE ABOVE LABELED 'VENDOR'



State of West Virginia  
 Department of Administration  
 Purchasing Division  
 2019 Washington Street East  
 Post Office Box 50130  
 Charleston, WV 25305-0130

# Request for Quotation

RFQ NUMBER
WEH60241

PAGE
3

ADDRESS CORRESPONDENCE TO ATTENTION OF
ROBERTA WAGNER 304-558-0067

VENDOR

RFQ COPY  
 TYPE NAME/ADDRESS HERE

SHIP TO

HEALTH AND HUMAN RESOURCES  
 WELCH COMMUNITY HOSPITAL  
  
 454 MCDOWELL STREET  
 WELCH, WV  
 24801 304-436-8710

DATE PRINTED	TERMS OF SALE	SHIP VIA	F.O.B.	FREIGHT TERMS
05/18/2006				

BID OPENING DATE: 07/05/2006 BID OPENING TIME 01:30PM

LINE	QUANTITY	UOP	CAT NO.	ITEM NUMBER	UNIT PRICE	AMOUNT
<p>WAGE RATES: THE CONTRACTOR OR SUBCONTRACTOR SHALL PAY THE HIGHER OF THE U.S. DEPARTMENT OF LABOR MINIMUM WAGE RATES AS ESTABLISHED FOR MCDOWELL COUNTY, PURSUANT TO WEST VIRGINIA CODE 21-5A, ET, SEQ. (PREVAILING WAGE RATES APPLY TO THIS PROJECT).</p> <p>ARBITRATION: ANY REFERENCES MADE TO ARBITRATION OR INTEREST FOR PAYMENTS DUE (EXCEPT FOR ANY INTEREST REQUIRED BY STATE LAW) CONTAINED IN THIS CONTRACT OR IN ANY AMERICAN INSTITUTE OF ARCHITECTS DOCUMENTS PERTAINING TO THIS CONTRACT ARE HEREBY DELETED.</p> <p>WORKERS' COMPENSATION: VENDOR IS REQUIRED TO PROVIDE A CERTIFICATE FROM WORKERS' COMPENSATION IF SUCCESSFUL.</p> <p>ALL OF THE ITEMS CHECKED BELOW WILL BE A REQUIREMENT OF THIS CONTRACT:</p> <p>(XX) INSURANCE: SUCCESSFUL VENDOR SHALL FURNISH PROOF OF COMMERCIAL GENERAL LIABILITY INSURANCE PRIOR TO ISSUANCE OF CONTRACT. UNLESS OTHERWISE SPECIFIED IN THE BID DOCUMENTS, THE MINIMUM AMOUNT OF INSURANCE COVERAGE REQUIRED IS \$250,000.</p> <p>(XX) BONDS: FIVE PERCENT (5%) OF THE TOTAL AMOUNT OF THE BID PAYABLE TO THE STATE OF WEST VIRGINIA, SHALL BE SUBMITTED WITH EACH BID AS A BID BOND. THE SUCCESSFUL BIDDER SHALL ALSO FURNISH A PERFORMANCE BOND AND LABOR/MATERIAL BOND FOR 100% OF THE AMOUNT OF THE CONTRACT. BONDS MAY BE PROVIDED IN THE FORM OF A CERTIFIED CHECK, IRREVOCABLE LETTER OF CREDIT, OR BOND FURNISHED BY A SOLVENT SURETY COMPANY AUTHORIZED TO DO BUSINESS IN THE STATE OF WEST VIRGINIA. A LETTER OF CREDIT SUBMITTED IN LIEU OF A PERFORMANCE AND LABOR &amp; MATERIAL BOND WILL ONLY BE ALLOWED FOR PROJECTS UNDER \$100,000. PERSONAL</p>						

SEE REVERSE SIDE FOR TERMS AND CONDITIONS

SIGNATURE	TELEPHONE	DATE
-----------	-----------	------

TITLE	FEIN	ADDRESS CHANGES TO BE NOTED ABOVE
-------	------	-----------------------------------

WHEN RESPONDING TO RFQ, INSERT NAME AND ADDRESS IN SPACE ABOVE LABELED 'VENDOR'



State of West Virginia  
 Department of Administration  
 Purchasing Division  
 2019 Washington Street East  
 Post Office Box 50130  
 Charleston, WV 25305-0130

# Request for Quotation

RFQ NUMBER
WEH60241

PAGE
4

ADDRESS CORRESPONDENCE TO ATTENTION OF
ROBERTA WAGNER 304-558-0067

RFQ COPY  
 TYPE NAME/ADDRESS HERE

VENDOR

SHIP TO

HEALTH AND HUMAN RESOURCES  
 WELCH COMMUNITY HOSPITAL

454 MCDOWELL STREET  
 WELCH, WV  
 24801 304-436-8710

DATE PRINTED	TERMS OF SALE	SHIP VIA	F.O.B.	FREIGHT TERMS
05/18/2006				

BID OPENING DATE: 07/05/2006 BID OPENING TIME 01:30PM

LINE	QUANTITY	UOP	CAT NO	ITEM NUMBER	UNIT PRICE	AMOUNT
<p>OR BUSINESS CHECKS ARE NOT ACCEPTABLE IN LIEU OF THE 5% BID BOND, PERFORMANCE BOND, OR LABOR AND MATERIAL BOND.</p> <p>REV. 11/00</p> <p>EXHIBIT 7</p> <p>DOMESTIC ALUMINUM, GLASS &amp; STEEL IN PUBLIC WORKS PROJECTS</p> <p>IN ACCORDANCE WITH WEST VIRGINIA CODE 5-19-1 ET., SEQ., EVERY CONTRACT FOR CONSTRUCTION, RECONSTRUCTION, ALTERATION, REPAIR, IMPROVEMENT OR MAINTENANCE OF PUBLIC WORKS, WHERE THE COST IS MORE THAN \$50,000 AND, IN THE CASE OF STEEL ONLY, WHERE THE COST OF STEEL IS MORE THAN \$50,000 OR WHERE MORE THAN 10,000 POUNDS OF STEEL ARE REQUIRED, THE STATE WILL ACCEPT ONLY ALUMINUM GLASS, OR STEEL PRODUCTS PRODUCED IN THE UNITED STATES. IN ADDITION, ITEMS OF MACHINERY OR EQUIPMENT PURCHASED FOR USE AT THE SITE OF PUBLIC WORKS SHALL BE MADE OF DOMESTIC ALUMINUM, GLASS OR STEEL, UNLESS THE COST OF THE PRODUCT IS LESS THAN \$50,000 OR LESS THAN 10,000 POUNDS OF STEEL ARE USED IN PUBLIC WORKS PROJECTS.</p> <p>FOREIGN MADE ALUMINUM, GLASS OR STEEL PRODUCTS MAY BE ACCEPTED ONLY IF THE COST OF DOMESTIC PRODUCTS IS FOUND TO BE UNREASONABLE. SUCH COST IS UNREASONABLE IF IT IS 20% OR MORE HIGHER THAN THE BID PRICE FOR FOREIGN MADE PRODUCTS. IF THE DOMESTIC ALUMINUM, GLASS OR STEEL PRODUCTS TO BE SUPPLIED OR PRODUCED IN A "SUBSTANTIAL LABOR SURPLUS AREA", AS DEFINED BY THE UNITED STATES DEPARTMENT OF LABOR, FOREIGN PRODUCTS MAY BE SUPPLIED ONLY IF DOMESTIC PRODUCTS ARE 30% OR MORE HIGHER IN</p>						

SEE REVERSE SIDE FOR TERMS AND CONDITIONS

SIGNATURE	TELEPHONE	DATE
TITLE	FEIN	ADDRESS CHANGES TO BE NOTED ABOVE

WHEN RESPONDING TO RFQ, INSERT NAME AND ADDRESS IN SPACE ABOVE LABELED 'VENDOR'



State of West Virginia  
 Department of Administration  
 Purchasing Division  
 2019 Washington Street East  
 Post Office Box 50130  
 Charleston, WV 25305-0130

# Request for Quotation

RFQ NUMBER  
**WEH60241**

PAGE  
**5**

ADDRESS CORRESPONDENCE TO ATTENTION OF  
**ROBERTA WAGNER  
 304-558-0067**

VENDOR

RFQ COPY  
 TYPE NAME/ADDRESS HERE

STATE

**HEALTH AND HUMAN RESOURCES  
 WELCH COMMUNITY HOSPITAL**

**454 MCDOWELL STREET  
 WELCH, WV  
 24801 304-436-8710**

DATE PRINTED <b>05/18/2006</b>	TERMS OF SALE	SHIP VIA	F.O.B.	FREIGHT TERMS
-----------------------------------	---------------	----------	--------	---------------

BID OPENING DATE: **07/05/2006** BID OPENING TIME **01:30PM**

LINE	QUANTITY	UOP	CAT NO	ITEM NUMBER	UNIT PRICE	AMOUNT
<p>PRICE THAN THE FOREIGN MADE PRODUCTS.</p> <p>IF, PRIOR TO THE AWARD OF A CONTRACT UNDER THE ABOVE PROVISIONS, THE SPENDING OFFICER OF THE SPENDING UNIT DETERMINES THAT THERE EXISTS A BID FOR LIKE FOREIGN ALUMINUM, GLASS OR STEEL THAT IS REASONABLE AND LOWER THAN THE LOWEST BID DOMESTIC PRODUCTS, THE SPENDING OFFICE MAY REQUEST, IN WRITING, A REEVALUATION AND REDUCTION IN THE LOWEST BID FOR SUCH DOMESTIC PRODUCTS. ALL VENDORS MUST INDICATE IN THEIR BID IF THEY ARE SUPPLYING FOREIGN ALUMINUM, GLASS OR STEEL.</p> <p>REV. 3/88</p> <p>EXHIBIT 9</p> <p>NOTICE FOR ISSUANCE &amp; ACKNOWLEDGEMENT OF CONSTRUCTION PROJECT ADDENDA</p> <p>THE ARCHITECT/ENGINEER AND/OR AGENCY SHALL BE REQUIRED TO ABIDE BY THE FOLLOWING SCHEDULE IN ISSUING CONSTRUCTION PROJECT ADDENDA FOR STATE AGENCIES:</p> <p>(1) THE ARCHITECT/ENGINEER SHALL PREPARE THE ADDENDUM AND A LIST OF ALL PARTIES THAT HAVE PROCURED DRAWINGS AND SPECIFICATIONS FOR THE PROJECT. THE ADDENDUM AND LIST SHALL BE FORWARDED TO THE BUYER IN THE STATE PURCHASING DIVISION. THE ARCHITECT/ENGINEER SHALL ALSO SEND A COPY OF THE ADDENDUM TO THE STATE AGENCY FOR WHICH THE CONTRACT IS ISSUED.</p> <p>(2) THE BUYER SHALL SEND THE ADDENDUM TO ALL INTERESTED PARTIES AND, IF NECESSARY, EXTEND THE BID OPENING DATE. ANY ADDENDUM SHOULD BE RECEIVED BY THE BUYER WITHIN FOURTEEN (14) DAYS PRIOR TO THE BID</p>						

SEE REVERSE SIDE FOR TERMS AND CONDITIONS

SIGNATURE	TELEPHONE	DATE
-----------	-----------	------

TITLE	FEIN	ADDRESS CHANGES TO BE NOTED ABOVE
-------	------	-----------------------------------

WHEN RESPONDING TO RFQ, INSERT NAME AND ADDRESS IN SPACE ABOVE LABELED 'VENDOR'



State of West Virginia  
 Department of Administration  
 Purchasing Division  
 2019 Washington Street East  
 Post Office Box 50130  
 Charleston, WV 25305-0130

# Request for Quotation

RFQ NUMBER  
**WEH60241**

PAGE  
**6**

ADDRESS CORRESPONDENCE TO ATTENTION OF:  
**ROBERTA WAGNER**  
**304-558-0067**

RFQ COPY

TYPE NAME/ADDRESS HERE

VENDOR

SHIP TO

**HEALTH AND HUMAN RESOURCES  
 WELCH COMMUNITY HOSPITAL**

**454 MCDOWELL STREET  
 WELCH, WV  
 24801 304-436-8710**

DATE PRINTED <b>05/18/2006</b>	TERMS OF SALE	SHIP VIA	F.O.B.	FREIGHT TERMS
-----------------------------------	---------------	----------	--------	---------------

BID OPENING DATE: **07/05/2006** BID OPENING TIME **01:30PM**

LINE	QUANTITY	UOP	CAT. NO.	ITEM NUMBER	UNIT PRICE	AMOUNT
<p>OPENING DATE.</p> <p>(3) ALL ADDENDA SHOULD BE FORMALLY ACKNOWLEDGED BY ALL BIDDERS AND SUBMITTED TO THE STATE PURCHASING DIVISION AND THE STATE AUDITOR'S OFFICE. THE SAME RULES AND REGULATIONS THAT APPLY TO THE ORIGINAL BIDDING DOCUMENT SHALL ALSO APPLY TO AN ADDENDUM DOCUMENT. THE ONLY EXCEPTION MAY BE FOR AN ADDENDUM THAT IS ISSUED FOR THE SOLE PURPOSE OF CHANGING A BID OPENING TIME AND/OR DATE.</p> <p>REV. 11/96</p> <p>EXHIBIT 10</p> <p>ADDENDUM ACKNOWLEDGEMENT</p> <p>I HEREBY ACKNOWLEDGE RECEIPT OF THE FOLLOWING CHECKED ADDENDUM(S) AND HAVE MADE THE NECESSARY REVISIONS TO MY PROPOSAL, PLANS AND/OR SPECIFICATION, ETC.</p> <p>ADDENDUM NOS.:</p> <p>NO. 1 ..... <i>[initials]</i></p> <p>NO. 2 ..... </p> <p>NO. 3 ..... </p> <p>NO. 4 ..... </p> <p>NO. 5 ..... </p> <p>I UNDERSTAND THAT FAILURE TO CONFIRM THE RECEIPT OF THE ADDENDUM(S) MAY BE CAUSE FOR REJECTION OF THE BIDS.</p>						

SEE REVERSE SIDE FOR TERMS AND CONDITIONS

SIGNATURE	TELEPHONE	DATE
TITLE	FEIN	ADDRESS CHANGES TO BE NOTED ABOVE

WHEN RESPONDING TO RFQ, INSERT NAME AND ADDRESS IN SPACE ABOVE LABELED 'VENDOR'



State of West Virginia  
 Department of Administration  
 Purchasing Division  
 2019 Washington Street East  
 Post Office Box 50130  
 Charleston, WV 25305-0130

# Request for Quotation

RFQ NUMBER  
**WEH60241**

PAGE  
**7**

ADDRESS CORRESPONDENCE TO ATTENTION OF:  
**ROBERTA WAGNER**  
**304-558-0067**

RFQ COPY  
 TYPE NAME/ADDRESS HERE

VENDOR

SHIP TO

HEALTH AND HUMAN RESOURCES  
 WELCH COMMUNITY HOSPITAL  
 454 MCDOWELL STREET  
 WELCH, WV  
 24801 304-436-8710

DATE PRINTED	TERMS OF SALE	SHIP VIA	F.O.B.	FREIGHT TERMS
05/18/2006				

BID OPENING DATE: **07/05/2006** BID OPENING TIME **01:30PM**

LINE	QUANTITY	UOP	CAT. NO.	ITEM NUMBER	UNIT PRICE	AMOUNT
<p>..... <i>Sandy Moore</i> ..... SIGNATURE            .. <i>Murray Sheet Metal Co. Inc.</i> ..... COMPANY            .... <i>June 27, 2006</i> ..... DATE</p> <p>REV. 11/96</p> <p>CONTRACTORS LICENSE</p> <p>WEST VIRGINIA STATE CODE 21-11-2 REQUIRES THAT ALL PERSONS DESIRING TO PERFORM CONTRACTING WORK IN THIS STATE MUST BE LICENSED. THE WEST VIRGINIA CONTRACTORS LICENSING BOARD IS EMPOWERED TO ISSUE THE CONTRACTORS LICENSE. APPLICATIONS FOR A CONTRACTORS LICENSE MAY B MADE BY CONTACTING THE WEST VIRGINIA DIVISION OF LABOR CAPITOL COMPLEX, BUILDING 3, ROOM 319, CHARLESTON, WV 25305. TELEPHONE: (304) 558-7890.</p> <p>WEST VIRGINIA STATE CODE 21-11-11 REQUIRES ANY PROSPECTIVE BIDDER TO INCLUDE THE CONTRACTORS LICENSE NUMBER ON THEIR BID.</p> <p>BIDDER TO COMPLETE:</p> <p>CONTRACTORS NAME: ..... <i>Murray Sheet Metal Co. Inc.</i> .....            CONTRACTORS LICENSE NO.: ..... <i>00006</i> .....</p> <p>THE SUCCESSFUL BIDDER WILL BE REQUIRED TO FURNISH A COPY OF THEIR CONTRACTORS LICENSE PRIOR TO ISSUANCE OF A PURCHASE ORDER/CONTRACT</p>						

SEE REVERSE SIDE FOR TERMS AND CONDITIONS

SIGNATURE	TELEPHONE	DATE
TITLE	FEIN	ADDRESS CHANGES TO BE NOTED ABOVE

WHEN RESPONDING TO RFQ, INSERT NAME AND ADDRESS IN SPACE ABOVE LABELED 'VENDOR'



State of West Virginia  
 Department of Administration  
 Purchasing Division  
 2019 Washington Street East  
 Post Office Box 50130  
 Charleston, WV 25305-0130

# Request for Quotation

RFQ NUMBER
WEH60241

PAGE
8

ADDRESS CORRESPONDENCE TO ATTENTION OF
ROBERTA WAGNER 304-558-0067

RFQ COPY  
 TYPE NAME/ADDRESS HERE

VENDOR

SHIP TO

HEALTH AND HUMAN RESOURCES  
 WELCH COMMUNITY HOSPITAL

454 MCDOWELL STREET  
 WELCH, WV  
 24801 304-436-8710

DATE PRINTED	TERMS OF SALE	SHIP VIA	F.O.B.	FREIGHT TERMS
05/18/2006				

BID OPENING DATE: 07/05/2006 BID OPENING TIME 01:30PM

LINE	QUANTITY	UOP	CAT NO	ITEM NUMBER	UNIT PRICE	AMOUNT
<p>APPLICABLE LAW</p> <p>THE WEST VIRGINIA STATE CODE, PURCHASING DIVISION RULES &amp; REGULATIONS, PURCHASING DIVISION POLICY STATEMENTS, AND THE INFORMATION PROVIDED IN THE "REQUEST FOR QUOTATION" ISSUED BY THE PURCHASING DIVISION IS THE SOLE AUTHORITY GOVERNING THIS PROCUREMENT.</p> <p>ANY INFORMATION PROVIDED IN SPECIFICATION MANUALS, OR ANY OTHER SOURCE, VERBAL OR WRITTEN, WHICH CONTRADICTS OR ALTERS THE INFORMATION PROVIDED FROM THE SOURCES AS DESCRIBED IN THE ABOVE PARAGRAPH IS VOID AND OF NO EFFECT.</p> <p>BANKRUPTCY: IN THE EVENT THE VENDOR/CONTRACTOR FILES FOR BANKRUPTCY PROTECTION, THIS CONTRACT IS AUTOMATICALLY NULL AND VOID, AND IS TERMINATED WITHOUT FURTHER ORDER.</p> <p>REV. 9/98</p> <p>NOTICE</p> <p>AN ORIGINAL, SIGNED BID MUST BE SUBMITTED ALONG WITH A CONVENIENCE COPY:            DEPARTMENT OF ADMINISTRATION            PURCHASING DIVISION            BUILDING 15            2019 WASHINGTON STREET, EAST            CHARLESTON, WV 25305-0130</p> <p>BIDS MUST CONTAIN THIS INFORMATION ON THE FACE OF THE ENVELOPE OR THE BID MAY NOT BE CONSIDERED:</p> <p>SEALED BID</p>						

SEE REVERSE SIDE FOR TERMS AND CONDITIONS

SIGNATURE	TELEPHONE	DATE
TITLE	FEIN	ADDRESS CHANGES TO BE NOTED ABOVE

WHEN RESPONDING TO RFQ, INSERT NAME AND ADDRESS IN SPACE ABOVE LABELED 'VENDOR'



State of West Virginia  
 Department of Administration  
 Purchasing Division  
 2019 Washington Street East  
 Post Office Box 50130  
 Charleston, WV 25305-0130

# Request for Quotation

RFQ NUMBER:  
**WEH60241**

PAGE:  
**9**

ADDRESS CORRESPONDENCE TO ATTENTION OF:  
**ROBERTA WAGNER  
 304-558-0067**

RFQ COPY  
 TYPE NAME/ADDRESS HERE

VENDOR

SHIP TO

**HEALTH AND HUMAN RESOURCES  
 WELCH COMMUNITY HOSPITAL  
 454 MCDOWELL STREET  
 WELCH, WV  
 24801 304-436-8710**

DATE PRINTED	TERMS OF SALE	SHIP VIA	F.O.B.	FREIGHT TERMS
05/18/2006				

BID OPENING DATE: **07/05/2006** BID OPENING TIME **01:30PM**

LINE	QUANTITY	UOP	CAT. NO.	ITEM NUMBER	UNIT PRICE	AMOUNT
<p>BUYER: RW-22            REQ. NO.: WEH60241            BID OPENING DATE: 07/05/06            BID OPENING TIME: 1:30 P.M.</p> <p>PLEASE PROVIDE A FAX NUMBER IN CASE IT IS NECESSARY TO CONTACT YOU REGARDING YOUR BID:            ..... <b>304-428-4623</b> .....</p> <p>PLEASE PRINT OR TYPE NAME OF PERSON TO CONTACT CONCERNING THIS QUOTE:            ..... <b>Sandy Moore</b> .....</p> <p>WORK IS TO BE PERFORMED IN ACCORDANCE WITH THE SPECIFICATIONS PROVIDED, ANY ADDENDA, AND THE PURCHASE ORDER AS ISSUED BY THE DEPARTMENT OF ADMINISTRATION, PURCHASING DIVISION.</p> <p>INQUIRIES: WRITTEN QUESTIONS SHALL BE ACCEPTED THROUGH CLOSE OF BUSINESS ON JUNE 9, 2006. QUESTIONS MAY BE SENT VIA USPS, FAX, COURIER OR EMAIL. IN ORDER TO ASSURE NO VENDOR RECEIVES AN UNFAIR ADVANTAGE, NO SUBSTANTIVE QUESTIONS WILL BE ANSWERED ORALLY. IF POSSIBLE, E-MAIL QUESTIONS ARE PREFERRED. ADDRESS INQUIRIES TO:            ROBERTA WAGNER            DEPARTMENT OF ADMINISTRATION            PURCHASING DIVISION</p>						

SEE REVERSE SIDE FOR TERMS AND CONDITIONS

SIGNATURE	TELEPHONE	DATE
TITLE	FEIN	ADDRESS CHANGES TO BE NOTED ABOVE

WHEN RESPONDING TO RFQ, INSERT NAME AND ADDRESS IN SPACE ABOVE LABELED 'VENDOR'



State of West Virginia  
 Department of Administration  
 Purchasing Division  
 2019 Washington Street East  
 Post Office Box 50130  
 Charleston, WV 25305-0130

# Request for Quotation

RFQ NUMBER
WEH60241

PAGE
10

ADDRESS CORRESPONDENCE TO ATTENTION OF
ROBERTA WAGNER 304-558-0067

VENDOR

RFQ COPY  
 TYPE NAME/ADDRESS HERE  
*Murray Sheet Metal Co Inc*  
*3112 Seventh Street*  
*Parkersburg WV. 26104*  
*304 422-5431*

SHIP TO

HEALTH AND HUMAN RESOURCES  
 WELCH COMMUNITY HOSPITAL  
  
 454 MCDOWELL STREET  
 WELCH, WV  
 24801 304-436-8710

DATE PRINTED	TERMS OF SALE	SHIP VIA	F.O.B.	FREIGHT TERMS
05/18/2006				

BID OPENING DATE: 07/05/2006 BID OPENING TIME 01:30PM

LINE	QUANTITY	UOP	CAT. NO	ITEM NUMBER	UNIT PRICE	AMOUNT
				2019 WASHINGTON STREET, EAST CHARLESTON, WV 25311 FAX: 304-558-4115 EMAIL: RWAGNER@WVADMIN.GOV		
<p>THE MODEL/BRAND/SPECIFICATIONS NAMED HEREIN ESTABLISH THE ACCEPTABLE LEVEL OF QUALITY ONLY AND ARE NOT INTENDED TO REFLECT A PREFERENCE OR FAVOR ANY PARTICULAR BRAND OR VENDOR. VENDORS WHO ARE BIDDING ALTERNATES SHOULD SO STATE AND INCLUDE PERTINENT LITERATURE AND SPECIFICATIONS. FAILURE TO PROVIDE INFORMATION FOR ANY ALTERNATES MAY BE GROUNDS FOR REJECTION OF THE BID. THE STATE RESERVES THE RIGHT TO WAIVE MINOR IRREGULARITIES IN BIDS OR SPECIFICATIONS IN ACCORDANCE WITH SECTION 148-1-4(F) OF THE WEST VIRGINIA LEGISLATIVE RULES AND REGULATIONS.</p>						
<p>***** THIS IS THE END OF RFQ WEH60241 ***** TOTAL: <i>\$64,169.00</i></p> <p><i>Sixty Four Thousand One Hundred Sixty Nine &amp; no/100</i></p>						

SEE REVERSE SIDE FOR TERMS AND CONDITIONS			
SIGNATURE	TELEPHONE	DATE	
TITLE	FEIN	ADDRESS CHANGES TO BE NOTED ABOVE	

WHEN RESPONDING TO RFQ, INSERT NAME AND ADDRESS IN SPACE ABOVE LABELED 'VENDOR'

WEH60241  
SPECIFICATIONS

STATE OF WEST VIRGINIA  
Department of Health and Human Resources  
Welch Community Hospital

**1. GENERAL INFORMATION**

- 1.1 Request for Quotation to provide all labor, materials, equipment and anything incidental to the provision and installation of Heating, Ventilating, and Cooling (HVAC) components and other certain renovations as listed herein for the Welch Community Hospital located at 454 McDowell Street, Welch, WV 24801.
- 1.2 All work shall be done in compliance with Fire Marshal regulations and all other building codes and industry standards. Final payment may be withheld if installed system is not in compliance. The award will be made to the overall low bid that complies with the specifications.
- 1.3 A mandatory on-site pre-bid conference will be held on June 13, 2006 at 11:00 AM. Failure to attend the pre-bid conference will result in bid disqualification.

**2. BASE BIDS:**

- 2.1 All qualified Bidders, being familiar with and understanding the bidding documents and also having examined the site and being familiar with all local conditions affecting the project hereby propose to furnish all labor, material, equipment and supplies to perform all work in accordance with the bidding documents within the time set forth below.
- 2.2 It is the bidder's responsibility to verify all field conditions and building limitations prior to bidding. It is also the bidder's responsibility to notify the West Virginia Department of Health & Human Resources in writing, of conditions detrimental to proper and timely completion of the installation. Do not proceed until nonconforming conditions have been corrected.

**3. SCOPE OF WORK:**

- 3.1 Contractor shall remove existing equipment and components and dispose of existing refrigerants, oil or any other contaminants at a landfill authorized to accept such materials and replace with Trane or approved equal components of equal or greater size as

specified. All wiring, rigging, installation refrigerant, refrigerant piping or specialties smoke detectors, water piping or specialties shall be included with the installation. This shall be a turn-key job, everything to totally complete the installation and approved operation shall be included on the original bid. This shall include replacement of the entire condensing and air handling units and the new units must be compatible with existing pneumatic controls in the mechanical rooms. The HVAC unit specified serves critical areas of the facility and time frames for down time need to be coordinated and limited.

- 3.2 Unit D4 - Remove and dispose of existing McQuay Corporation air handling unit and condensing unit and replace with Trane or equal, of equal or greater size, air cooled condensing unit. Includes, but not limited to 7.5 ton system, 85.7 MBH 460 Volt, 60 Hertz, 3 phase, constant volume control, low ambient damper(s) control, UL/CSA approval, suction service valve, unit disconnect switch (non-fused), hot gas bypass valve, pressure gauges and piping, unit spring isolators, 5 year compressor warranty (parts only) and start-up services.

#### **4. INSPECTION:**

- 4.1 Contractor shall inspect existing conditions governing this work during pre-bid site inspection to determine conditions and extent of work required. No allowance will be made subsequently on behalf of the contractor for any error or negligence on his part in connection with this requirement.
- 4.2 The Contractor shall inspect all elements subject to movement or damage prior to commencing work.

#### **5. SHOP DRAWINGS:**

- 5.1 Contractor shall provide two (2) sets of shop drawings to owner for approval specifying products and installation methods for the scope of work as defined in Section 3. A notice to proceed will be issued indicating owner's approval of the shop drawings.

#### **6. TEMPORARY FACILITIES:**

- 6.1 The Owner's will provide normal electrical supply from the currently installed electrical system in the building for the use of the contractor. However, the Owner provides no guarantee or warranty

as to the systems condition or capabilities. The Contractor shall assure himself that the electrical system is adequate for his requirements or supply additional temporary electrical power at his own expense.

- 6.2 Any damage to the electrical system resulting from misuse or abuse to the existing electrical system shall be repaired or replaced by the contractor at no expense to the owner.

### **7. COORDINATION OF WORK:**

- 7.1 The Contractor shall coordinate with the maintenance supervisor for the proper relation of the work to the building structure and to the employees therein. In the event of conflict the building employees shall prevail.
- 7.2 The Contractor shall take all necessary precautions to protect the interior of the building from debris, dust or any residues resulting from the work:
- 7.3 The Contractor shall provide the Owner with a schedule of work seven calendar days prior to the start of the work. The Owner shall be notified of any variances to the work schedule two (2) working days prior to the change.

### **8. WARRANTY: (GUARANTEE)**

- 8.1 The Contractor warrants to the Owner all materials and equipment will be new, and that all work will be of good quality, free from faults and defects in conformance with the contract documents. All work not conforming with these requirements may be considered defective.
- 8.2 Bidder should include all warranty details with bid. Warranty should be a minimum of one (1) year on main unit and a minimum of five (5) years on compressor.

### **9. PERMITS:**

- 9.1 The Contractor shall secure and pay for the building permit and for all other permits, governmental fees and licenses which are necessary for the proper execution and completion of the work as specified.

**10. CLEAN UP:**

- 10.1 The Contractor shall keep the work area as clean as possible during the entire progress of work, and shall be responsible to remove from the site, the packaging materials from his products and other debris as it accumulates.

**11. WAGE RATES:**

- 11.1 The Contractor and any sub-contractors shall pay the higher of the U.S. Department of Labor Minimum wage rates or of the West Virginia Department of Labor wage rates as established for **MCDOWELL COUNTY** pursuant to West Virginia Code 21-5-1, et seq.

**12. PROGRESS PAYMENTS:**

- 12.1 Due to the size and complexity of the project, one payment will be permitted at 100% completion.
- 12.2 The Contractor shall submit to the Owner one original invoice for payment, supported by such data substantiating the contractor's right to payment under the terms in this contract. After agreement by both parties, the Owner shall make payment.
- 12.3 Application for payment shall be submitted to the Owner for work completed and approved by the Owner. The Owner reserves the right to refuse payment in the event the completed work is not commensurate with the amount shown on the Application for Payment or if the completed work is not in accordance with industry standards or sub-standard in any way.
- 12.4 Payment for the completion of this project shall be made by the Owner to the Contractor when the contract work is completed in its entirety and inspected and approved by the Owner.

**13. TERM OF WORK:**

- 13.1 All work shall be complete within 120 calendar days from the issuance of the notice to proceed.

**14. DELAYS AND EXTENSION OF TIME:**

- 14.1 If the Contractor is delayed at any time in the progress of the work

by any act or neglect of the Owner or by any employee of the Owner, or by any separate contractor employed by the Owner, or by changes in the work, or by labor disputes, fire, unusual delay in transportation, adverse weather conditions not reasonably anticipated, unavoidable casualties, or any other cause which the Owner determines may justify the delay, then the contract time may be extended by written approval of the Owner.

**15. TOOLS AND EQUIPMENT STORAGE:**

15.1 Contractor shall set a trailer or temporary storage building on the site for all equipment and tools. The Contractor is responsible for his tools, equipment and materials.

**16. SAFETY EQUIPMENT:**

16.1 The Contractor shall provide safety barriers around work areas where heavy equipment may be in operation when placing materials on the building or at times as required by OSHA.

**17. DAMAGES:**

17.1 Any damages occurring to the building or property resulting from the performance of this work shall be the responsibility of the contractor to repair at his expense, either by using his own forces or that of a sub-contractor. The repair method and finished product will be subject to the approval of the owner.

**18. SCHEDULE OF BID RESPONSES**

18.1 Bidders should also submit full warranty information with his bid for the scope of work as described in section 3. The warranty information shall minimally contain the labor and material warranty.

18.3 Only those bidders with a minimum of three (3) successful project completions will be considered. The Bidders are requested to submit letters of reference from the Building Owner, including the name, address, and telephone number of a contact person (someone specifically familiar with the Contractor's work) for at least three (3) previous users of service. Include descriptions of projects, locations, and records that were generated during the project. The letters of reference are not mandatory but vendor should be able to provide references upon request.

**A F F I D A V I T****West Virginia Code §5A-3-10a states:**

No contract or renewal of any contract may be awarded by the state or any of its political subdivisions to any vendor or prospective vendor when the vendor or prospective vendor or a related party to the vendor or prospective vendor is a debtor and the debt owned is an amount greater than one thousand dollars in the aggregate.

**DEFINITIONS:**

"Debt" means any assessment, premium, penalty, fine, tax or other amount of money owed to the state or any of its political subdivisions because of a judgment, fine, permit violation, license assessment, defaulted workers' compensation premium, penalty or other assessment presently delinquent or due and required to be paid to the state or any of its political subdivisions, including any interest or additional penalties accrued thereon.

"Debtor" means any individual, corporation, partnership, association, limited liability company or any other form or business association owing a debt to the state or any of its political subdivisions.

"Political subdivision" means any county commission; municipality; county board of education; any instrumentality established by a county or municipality; any separate corporation or instrumentality established by one or more counties or municipalities, as permitted by law; or any public body charged by law with the performance of a government function or whose jurisdiction is coextensive with one or more counties or municipalities:

"Related party" means a party, whether an individual, corporation, partnership, association, limited liability company or any other form or business association or other entity whatsoever, related to any vendor by blood, marriage, ownership or contract through which the party has a relationship of ownership or other interest with the vendor so that the party will actually or by effect receive or control a portion of the benefit, profit or other consideration from performance of a vendor contract with the party receiving an amount that meets or exceeds five percent of the total contract amount.

**EXCEPTION:**

The prohibition of this section does not apply where a vendor has contested any tax administered pursuant to chapter eleven of this code, workers' compensation premium, permit fee or environmental fee or assessment and the matter has not become final or where the vendor has entered into a payment plan or agreement and the vendor is not in default of any of the provisions of such plan or agreement.

**LICENSING:**

The vendor must be licensed in accordance with any and all state requirements to do business with the state of West Virginia.

**CONFIDENTIALITY:**

The vendor agrees that he or she will not disclose to anyone, directly or indirectly, any such personally identifiable information or other confidential information gained from the agency, unless the individual who is the subject of the information consents to the disclosure in writing or the disclosure is made pursuant to the agency's policies, procedures and rules. Vendors should visit [www.state.wv.us/admin/purchase/privacy](http://www.state.wv.us/admin/purchase/privacy) for the Notice of Agency Confidentiality Policies.

Under penalty of law for false swearing (West Virginia Code, §61-5-3), it is hereby certified that the vendor acknowledges the information in this said affidavit and are in compliance with the requirements as stated.

Vendor's Name: Murray Sheet Metal Co. Inc.

Authorized Signature: Randall K. Rogers Date: June 28, 2006

**TECHNICAL DATA**

Date Saved : 21/06/2006 13:08:00

<b>JOB NAME</b>	48D861(RH001)	<b>REP. OFFICE</b>	Mason & Barry Inc.
<b>JOB DESCRIPTION</b>	Unit D4 Quote for welch	<b>SALESMAN</b>	GLB
<b>MODEL NUMBER</b>	RDS708B	<b>ENGINEER</b>	-
<b>UNIT TAGGING</b>	Unit D-4	<b>VERSION</b>	4.27

<b>SUPPLY</b>		<b>RETURN / EXHAUST</b>	
Air volume	2800		s cfm
Altitude	700		ft
External static	2.00	0.50	ins WC
Total static	2.69		ins WC

<b>CASING DETAILS</b>	
Unit dimensions (H x W x L ins)	52 x 68 x 180
Unit weight ( lbs )	2337
Exterior	Beige polyester paint exceeding ASTM B117 salt spray standard
Liner	None
Insulation	1", 3/4# fiberglass
Doors	Single lever access doors on both sides

<b>ELECTRICAL DETAILS</b>	
Unit voltage	460/60/3
MCA ( amps )	5.6
MROPD ( amps )	15.0
Field connection	1 Power block
Control box location	Supply fan section

<b>CONTROLS DETAILS</b>	
Temperature controls	Power package
Airflow controls	None
Auxiliary controls	None
Starting options	Across the line

<b>SPECIALS</b>			
Static pressure	0.00	ins WC	Weight
			0.00
			lbs

<b>RETURN AIR SECTION</b>			
Return air option	Mixing box	Plenum options	None
Opening location	Bottom	Smoke detector	None
Air pressure drop	0.02	ins WC	

<b>FILTER SECTION</b>			
Type	Angular	Face area	20.8
Efficiency	30	%	Air pressure drop
			0.05
Face velocity	135	fpm	
			ft2
			ins WC

**COMBINATION COOLING COIL & HEATING COIL SECTION**

**HOT WATER COIL**

Coil model	5WB0801C	Number of coils	1
Capacity	96135 Btu/h	Number of rows	1
Entering db	60.0 F	Fins per inch	8
Leaving db	92.2 F	Entering water	180.0 F
Finned height x length	39.0 x 48.0 ins	Leaving water	158.5 F
Face area	13.0 ft <sup>2</sup>	Water flow rate	8.90 gpm
Face velocity	215 ft/m	Coil water PD	0.40 ftHD
Coil air pressure drop	0.03 ins WC	Valve water PD	0.00 ftHD
Connection type	C steel (Threaded)	Piping water PD	0.00 ftHD
Connection Qty x size	1.50 ins	Water velocity	1.50 ft/s
Connection location	Opposite drive side	Fin material	0.0075" Aluminum
Glycol type (%)	None	Tube material	0.020" Nom Cu std
		Header material	Copper
		Case material	Galvanized steel
Coil code	5WB0801C0390004800HRHRCGAHH2OSC017A7ST0300C000300C0001500150YAYAA YYYYYYYYYYYYYYYYYYYY		

**DIRECT EXPANSION COIL**

Coil model	5EN1205C	Number of coils	1
Total capacity	137265 Btu/h	Number of rows	5
Sensible capacity	87707 Btu/h	Fins per inch	12
Entering db/wb	80.0 / 67.0 F	Evaporating temp.	45.0 F
Leaving db/wb	50.6 / 50.4 F	Refrigerant	R22
Finned height x length	39.0 x 48.0 ins	Refrigerant pd	0.00 ftHD
Face area	13.0 ft <sup>2</sup>	Fin material	0.0075" Aluminum
Face velocity	210 ft/m	Tube material	0.020" Nom Cu std
Coil air pressure drop	0.31 ins WC	Header material	Copper
Connection type	Cu tube (O.D. Sweat)	Case material	Galvanized steel
Suction / Liquid conn	1-1.63 ins	Drain pan	Painted galvanized
Coil code	5EN1205C0390004800HLHRCG7130822SC017A7CMYY0300C0001500150TAYAAAYYY YYYYYYYY		

**SUPPLY FAN SECTION**

Air volume	2800 cfm	Motor power	3.00 hp
Total static pressure	2.69 ins WC	Motor type	ODP, High efficiency
Fan type/Class	DWDI FC / Class I	Motor efficiency	High
Fan wheel diameter	15.00 ins	Full load current	4.5 A
Brake horsepower	2.25 hp	Lock rotor current	32.3 A
Operating speed	1116.7 rpm	Drive ser. factor/Type	Standard / Variable pitch
Air modulation	No modulation	Fan isolation	Rubber in shear

**DRIVES**

Fan sheave	AK66	Motor sheave	1VP50L
Number of belts	1	Belt	A59

**DISCHARGE PLENUM SECTION**

Opening location	Bottom	Smoke detector	None
Plenum options	None	Air pressure drop	0.28 ins WC

**NOTES**

**TECHNICAL DATA**

Date Saved : 21/06/2006 13:08:00

<b>SHIPPING SECTION DETAILS</b>		
	<b>Length (inches)</b>	<b>Weight (lb)</b>
Section 1	180.00	2337.00
<b>TOTALS</b>	<b>180.00</b>	<b>2337.00</b>

<b>WARRANTY DETAILS</b>		
	<b>Parts</b>	<b>Heat Exchanger</b>
Standard ( yrs )		0
Extended ( yrs )		0

<b>UNIT SOUND</b>	63 Hz	125 Hz	250 Hz	500 Hz	1000 Hz	2000 Hz	4000 Hz	8000 Hz
Radiated	64	60	55	49	48	36	26	20
Unit discharge	82	75	73	70	71	65	58	52
Unit return	81	76	73	67	66	58	51	44

**McQUAY INTERNATIONAL FAN SELECTION**

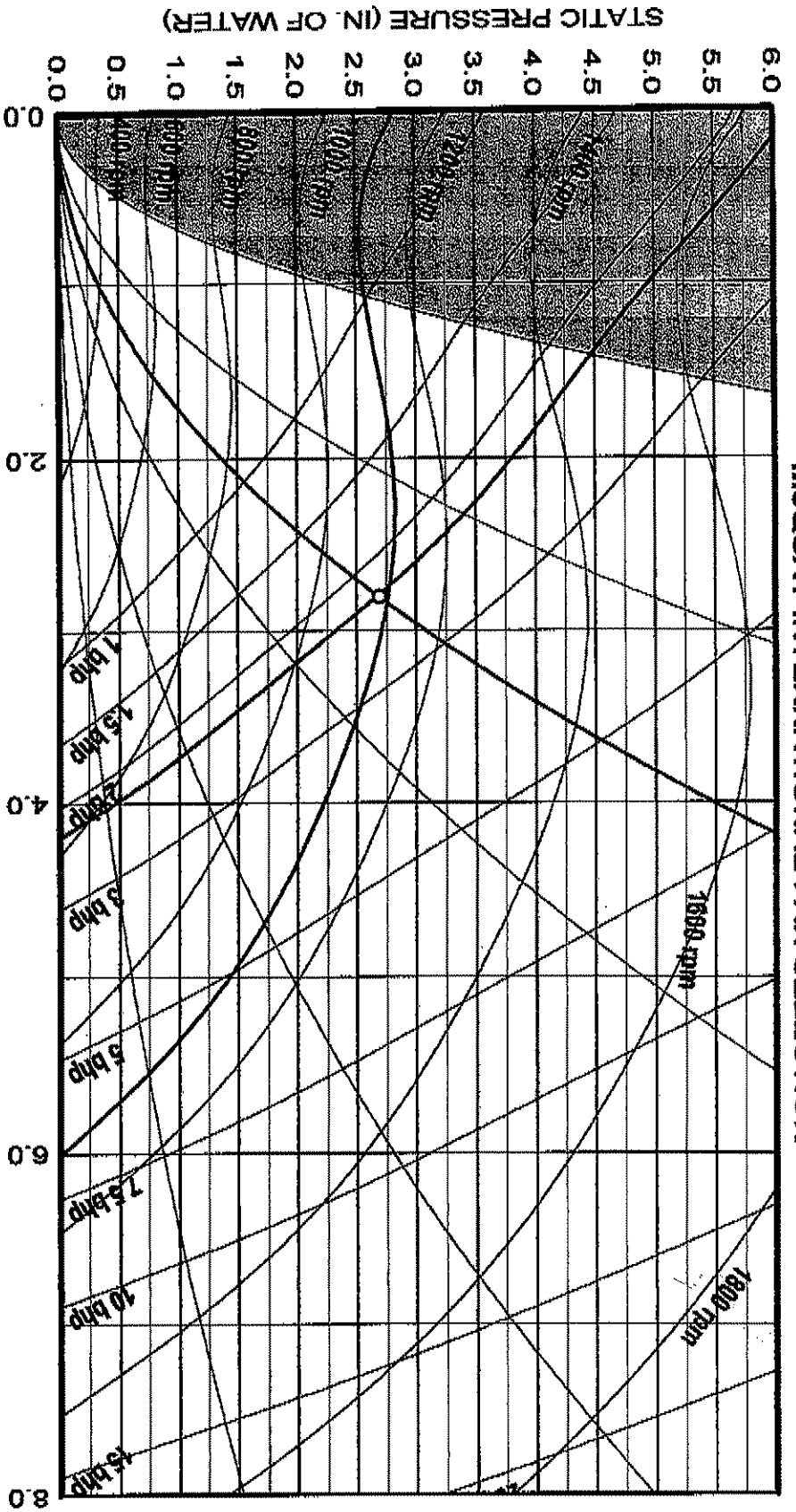

**15X6 Forward Curved Supply Fan at Standard Conditions**

Air volume	2800	cfm	Fan speed	1117	rpm
Total static	2.69	insWg	Max speed	3500	rpm
Brake horsepower	2.3	bhp	Efficiency	52.5	%
Unit tagging	Unit D-4		Date	21-June-2006	
Job name	Unit D4 Quote for welch		Time	13:21	

# McQuay International Psychrometric Chart

Ent DB	60.0	°F
Ent WB	60.0	°F
Lev DB	92.2	°F
Lev WB	92.2	°F
Duty	96135	Btu/hr

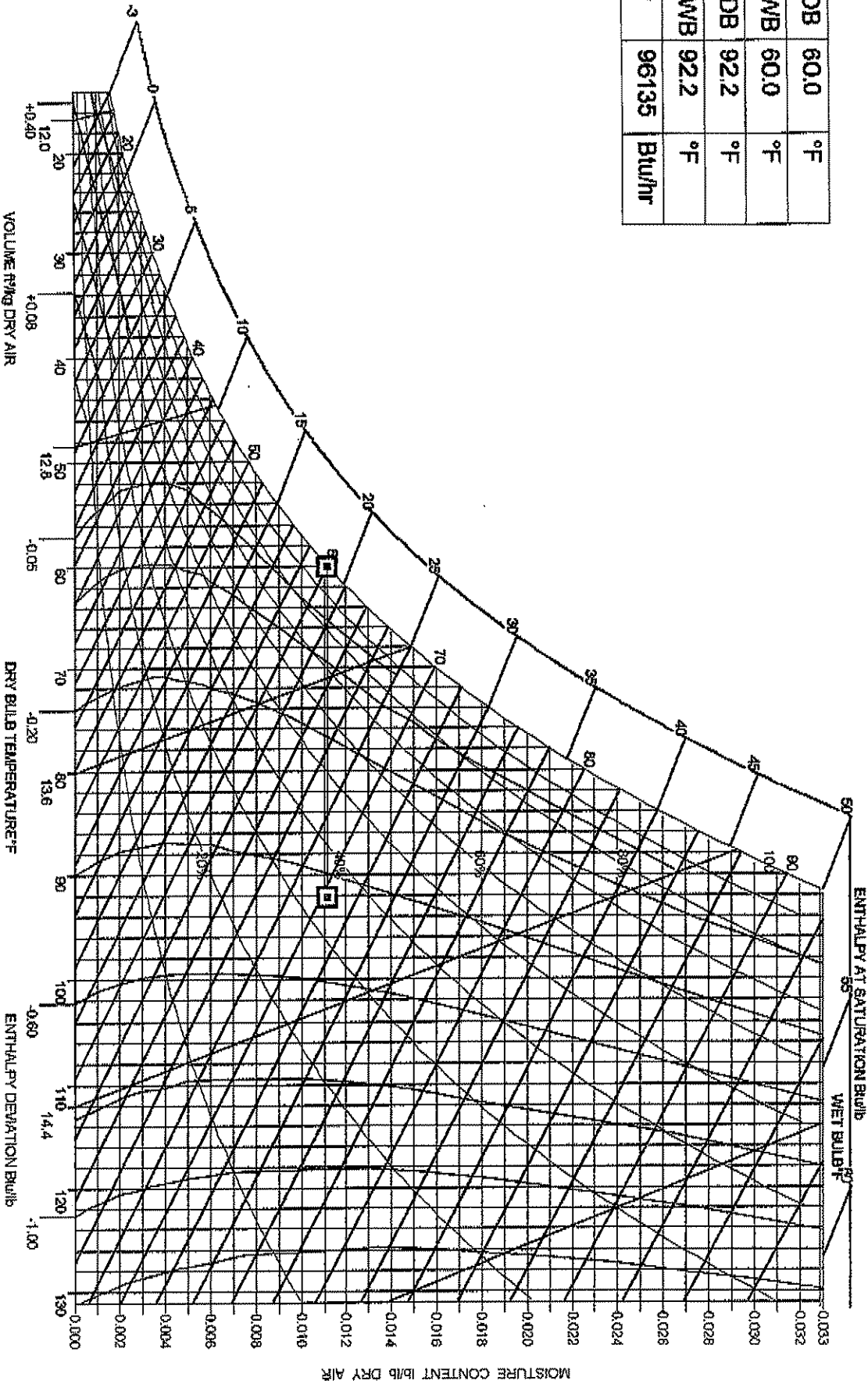

UNIT TAGGING : Unit D-4  
 JOB NAME : Unit D4 Quote for welch

DATE : 21-June-2006  
 TIME : 13:21

Opening	X	Y	Z	W(Width)	H(Height)
A Return air inlet	6.50	8.75	0.00	50.00	20.00
B Coil piping entrance	107.00	41.50	0.00	18.00	6.00
C Condensate drain connection (1.5 MPT)	101.32	-1.50	3.83	-	-
D Discharge air outlet	153.50	8.75	0.00	50.00	20.00

Dimensions measured from ⊕

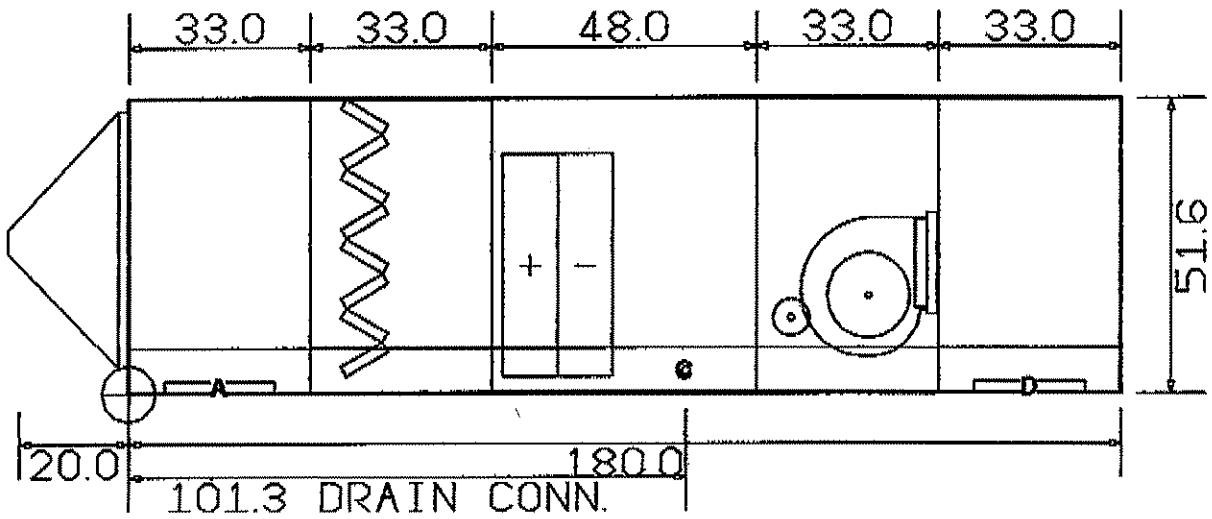

VIEW: Right Side  
 DRAWN: 21-June-2006 (13:06)  
 JOB NAME: Unit D4 Quote for welch  
 UNIT TAGGING: Unit D-4  
 MODEL: RDS708B



Opening	X	Y	Z	W(Width)	H(Height)
A Return air inlet	6.50	8.75	0.00	50.00	20.00
B Coil piping entrance	107.00	41.50	0.00	18.00	6.00
C Condensate drain connection (1.5 MPT)	101.32	-1.50	3.83	-	-
D Discharge air outlet	153.50	8.75	0.00	50.00	20.00

Dimensions measured from ⊕

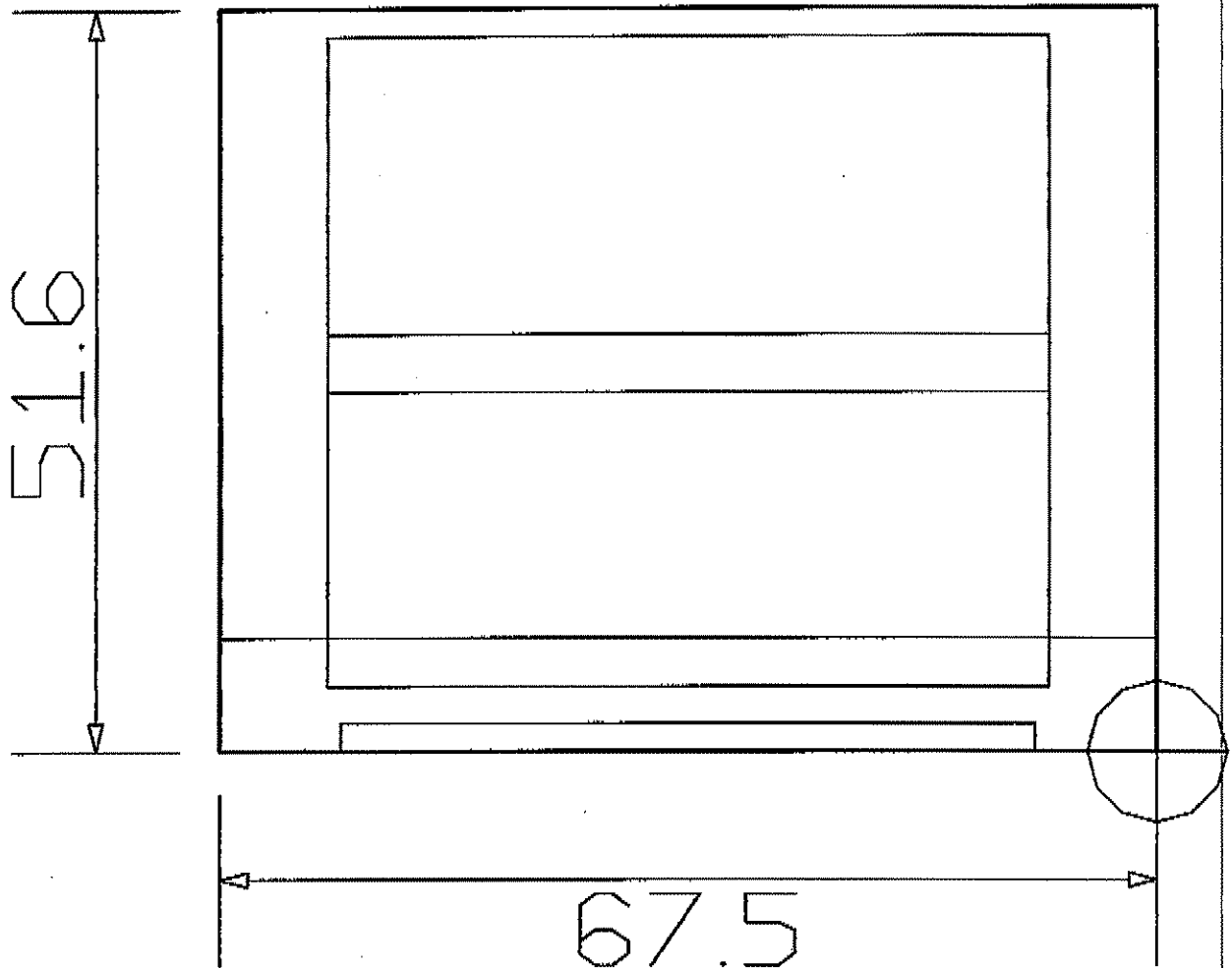

VIEW: Inlet  
 DRAWN: 21-June-2006 (13:06)  
 JOB NAME: Unit D4 Quote for welch  
 UNIT TAGGING: Unit D-4  
 MODEL: RDS708B



**Coil Piping Vestibule**

- A** 48.25
- B** 18.0
- C** 49.5
- D** 0.5

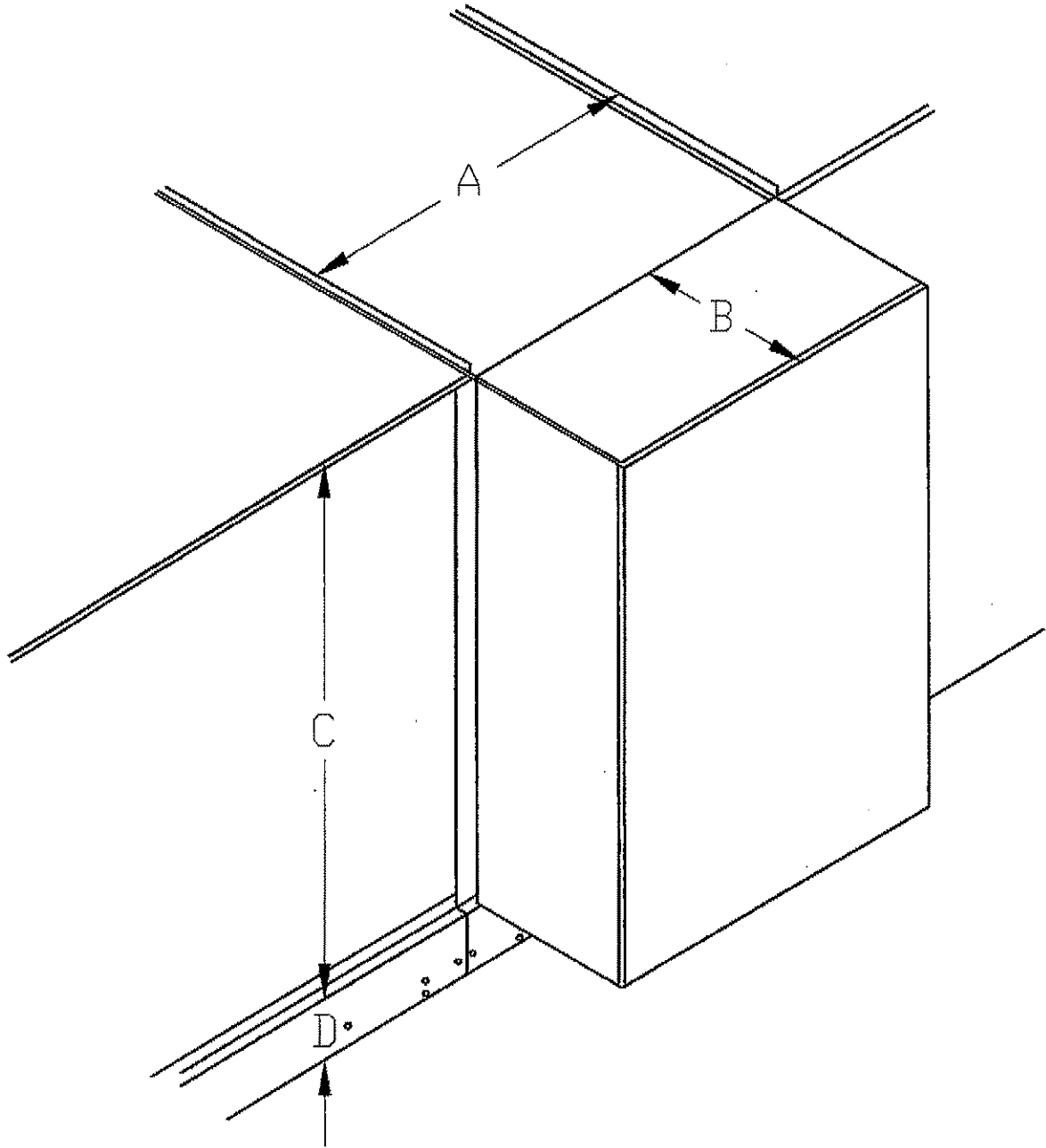

**VIEW:** Figure 1  
**DRAWN:** 21-June-2006 (13:06)  
**JOB NAME:** Unit D4 Quote for weich  
**UNIT TAGGING:** Unit D-4  
**MODEL:** RDS708B



**Roof Curb**

- A 171.3
- B 20.0
- C 50.0
- D 2.13
- E 1.63

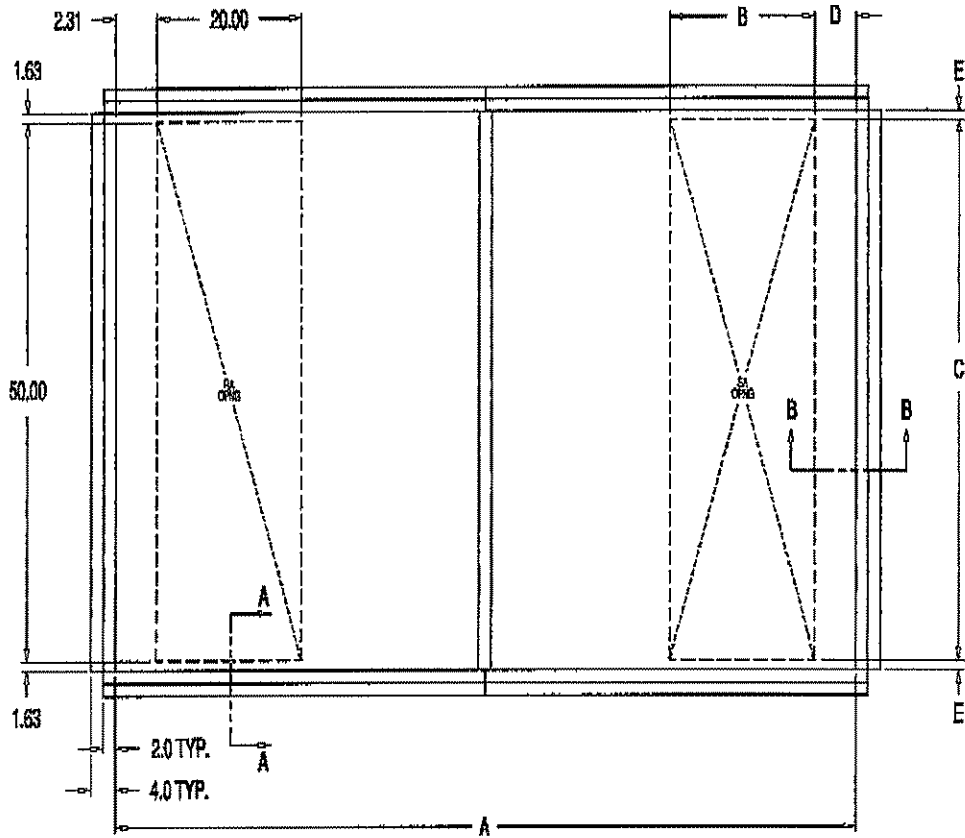

VIEW: Figure 2  
DRAWN: 21-June-2006 (13:06)  
JOB NAME: Unit D4 Quote for welch  
UNIT TAGGING: Unit D-4  
MODEL: RDS708B



Roof Curb Cross Section

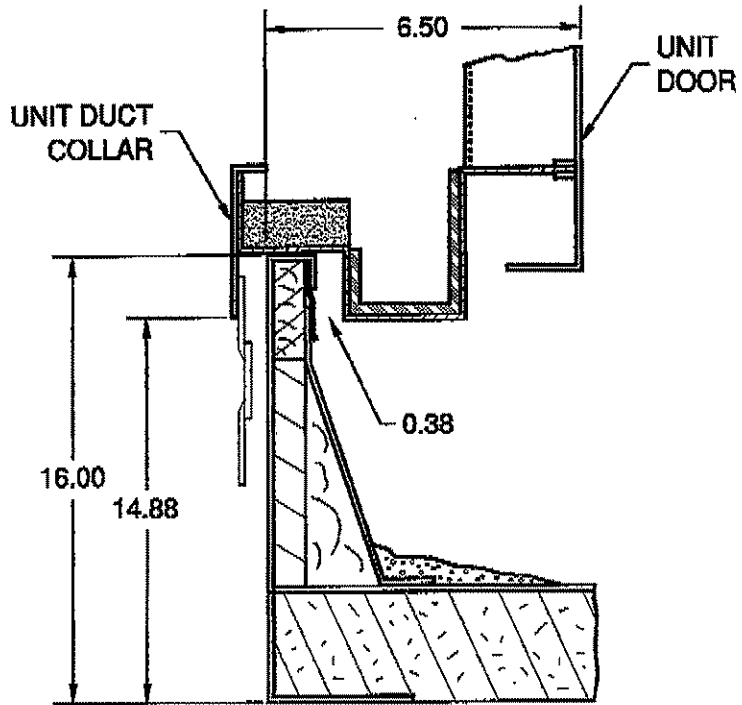

A-A

VIEW: Figure 3  
DRAWN: 21-June-2006 (13:06)  
JOB NAME: Unit D4 Quote for weich  
UNIT TAGGING: Unit D-4  
MODEL: RDS708B

**McQuay**<sup>®</sup>  
Air Conditioning

Roof Curb Cross Section

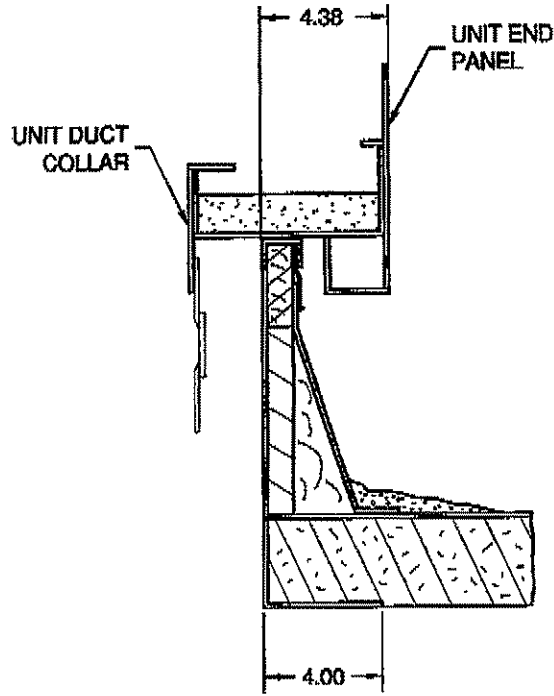

B-B

VIEW: Figure 4  
DRAWN: 21-June-2006 (13:06)  
JOB NAME: Unit D4 Quote for welch  
UNIT TAGGING: Unit D-4  
MODEL: RDS708B



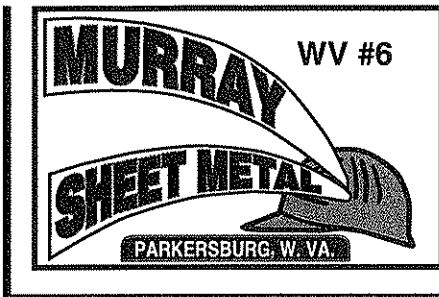

Industrial  
Residential  
Commercial  
Sheet Metal  
Roofing  
Welding

3112 Seventh Street • Parkersburg, WV 26101 • Phone: 304/422-5431 • FAX 304/428-4623

June 27, 2006

Ref. RFQ:WEH60241

Murray Sheet Metal Co. Inc. intends to use McQuay equipment as an alternate on this job. Specifications are included in the bid package.

We also intend working 12 hour days in order to expedite the work as specified in the bid package in order to minimize the down time for the X-Ray department. We plan to have the new equipment up and operating on the third day after we begin the change out. Our pricing reflects the overtime hours and the extra man power to accomplish this task in the shortest possible time.

We at Murray Sheet Metal Co. Inc. realize the importance of the X-Ray department to the patients and the hospital itself.

Thank you for considering Murray Sheet Metal Co. Inc.

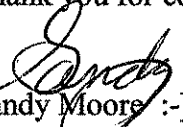
  
Sandy Moore :-]  
HVAC Service Manager  
Murray Sheet Metal Co. Inc.

Agency Purchasing  
REQ. P. O# WEL60241

BID BOND

KNOW ALL MEN BY THESE PRESENTS, That we, the undersigned, Murray Sheet Metal Co., Inc.  
of 3112 7th St Parkersburg WV 26101, as Principal, and American Southern Insurance Company  
of 18051 Jefferson Park Rd #104 Middleburg Hts, OH 44130  
Kansas with its principal office in the City of Atlanta GA, as Surety, are held and firmly bound unto the State  
of West Virginia, as Obligee, in the penal sum of Three Thousand Five Hundred Seventy Five (\$ - 3,575.00) for the payment of which,  
well and truly to be made, we jointly and severally bind ourselves, our heirs, administrators, executors, successors and assigns.

The Condition of the above obligation is such that whereas the Principal has submitted to the Purchasing Section of the  
Department of Administration a certain bid or proposal, attached hereto and made a part hereof, to enter into a contract in writing for  
HVAC Replacement @ Welch Community Hospital

NOW THEREFORE,

- (a) If said bid shall be rejected, or
- (b) If said bid shall be accepted and the Principal shall enter into a contract in accordance with the bid or proposal attached hereto and shall furnish any other bonds and insurance required by the bid or proposal, and shall in all other respects perform the agreement created by the acceptance of said bid, then this obligation shall be null and void, otherwise this obligation shall remain in full force and effect. It is expressly understood and agreed that the liability of the Surety for any and all claims hereunder shall, in no event, exceed the penal amount of this obligation as herein stated.

The Surety, for the value received, hereby stipulates and agrees that the obligations of said Surety and its bond shall be in no way impaired or affected by any extension of the time within which the Obligee may accept such bid, and said Surety does hereby waive notice of any such extension.

IN WITNESS WHEREOF, Principal and Surety have hereunto set their hands and seals, and each of them as are corporations have caused their corporate seals to be affixed hereunto and these presents to be signed by their proper officers, this

5th day of July, 2006

Principal Corporate Seal

Murray Sheet Metal Co Inc  
(Name of Principal)  
By [Signature]  
(Must be President or Vice President)  
PRESIDENT  
(Title)

Surety Corporate Seal

American Southern Insurance Company  
(Name of Surety)  
[Signature]  
Attorney-in-Fact  
Jeffery L. Booth

IMPORTANT - Surety executing bonds must be licensed in West Virginia to transact surety insurance. Raised corporate seals must be affixed, a power of attorney must be attached.

# AMERICAN SOUTHERN INSURANCE COMPANY

Home Office: 200 S.W. 30th Street  
Topeka, Kansas 66611

Mailing Address: 3715 Northside Pkwy, NW  
Bldg 400, Ste 800  
Atlanta, Georgia 30327

## GENERAL POWER OF ATTORNEY

Know all men by these Presents, that the American Southern Insurance Company had made, constituted and appointed, and by these presents does make, constitute and appoint Scott E. Stoltzner of Hoover, Alabama; Arthur S. Johnson of Atlanta, Georgia; Jessica B. Gardiner of Loganville, Georgia; Mary F. Holland of Chamblee, Georgia; Donald H. Gibbs of Atlanta, Georgia; Andrew C. Heaner of Atlanta, Georgia; Richard L. Shanahan of Atlanta, Georgia; Katherine S. Grimsley of Tampa, Florida; Jeffery L. Booth of Parma, Ohio; James E. Feldner of West Lake Ohio; Cheryl L. Torrao of Canton, Georgia; Garry W. Black of Murfreesboro, Tennessee; or David R. Brett of Columbia, South Carolina, EACH as its true and lawful attorney for it and its name, place and stead to execute on behalf of the said company, as surety, bonds, undertakings and contracts of suretyship to be given to all obligees provided that no bond or undertaking or contract of suretyship executed under this authority shall exceed in amount of the sum of \$850,000 (eight hundred fifty thousand dollars), including but not limited to consents of surety for the release of retained percentages and/or final estimates on construction contracts or similar authority requested by the Department of Transportation, State of Florida; and the execution of such undertakings, bonds, recognizances and other surety obligations, in pursuance of the presents, shall be as binding upon the Company as if they had been duly signed by the President and attested by the Secretary of the Company in their own proper persons.

This Power of Attorney is granted and is signed and sealed by facsimile under and by the authority of the following Resolution adopted pursuant to due authorization by the Executive Committee of the Board of Directors of the American Southern Insurance Company on the 26th day of May, 1998:

RESOLVED, that the Chairman, President or any Vice President of the Company be, and that each or any of them hereby is, authorized to execute Powers of Attorney qualifying the attorney named in the given Power of Attorney to execute in behalf of the American Southern Insurance Company bonds, undertakings and all contracts of suretyship; and that any Secretary or any Assistant Secretary be, and that each or any of them hereby is, authorized to attest the execution of any such Power of Attorney, and to attach thereto the seal of the Company.

FURTHER RESOLVED, that the signature of such officers and the seal of the Company may be affixed to any such Power of Attorney or to any certificate relating thereto by facsimile, and any such Power of Attorney or certificate bearing such facsimile signatures or facsimile seal shall be valid and binding upon the Company when so affixed and in the future, with respect to any bond undertaking or contract of suretyship to which it is attached.

In Witness Whereof, the American Southern Insurance Company has caused its official seal to be hereto affixed, and these presents to be signed by its President and attested by its Secretary this 16th day of May, 2006.

Attest:   
Gail A. Lee, Secretary

By: American Southern Insurance Company

  
Scott G. Thompson, President

STATE OF GEORGIA

SS:

COUNTY OF FULTON

On this 16th day of May, 2006, before me personally came Scott G. Thompson to me known, who being by me duly sworn, did depose and say that he resides in Atlanta, in the County of Fulton, State of Georgia, at 421 Hollydale Court; that he is the President of American Southern Insurance Company, the corporation described in and which executed the above instrument; that he knows the seal of the said corporation; that the seal affixed to the said instrument is such corporate seal; that it was so affixed and that he signed his name thereto pursuant to due authorization.

STATE OF GEORGIA

SS:

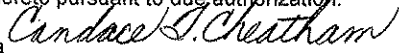
  
Candace T. Cheatham  
Notary Public, State of Georgia  
Qualified in DeKalb County

Commission Expires December 7, 2009

COUNTY OF FULTON

I, the undersigned, a Vice President of American Southern Insurance Company, a Kansas Corporation, DO HEREBY CERTIFY that the foregoing and attached Power of Attorney remains in full force and has not been revoked; and, furthermore, that the Resolution of the Executive Committee of the Board of Directors set forth in the Power of Attorney is now in force.

Signed and sealed at the City of Atlanta, Dated the 5th day of July, 2006

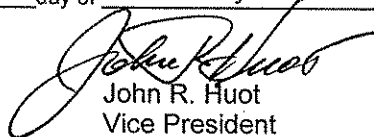
  
John R. Huot  
Vice President



**American Southern Insurance Company**  
**NAIC Company Code 10235**  
**NAIC Group Code 587**

**Statutory Financial Statement**

**As of December 31, 2005**

<b>ASSETS</b>		<b>LIABILITIES</b>	
Bonds	\$ 53,002,082	Reserve for Losses and Loss Expense	\$ 30,767,550
Stocks	29,024,472	Reserve for Unearned Premiums	25,603,015
Cash and Short - Term Investments	9,949,824	Reserve for Expenses, Taxes, Licenses and Fees	8,096,505
Agents Balances or Uncollected with Reinsured Companies	9,957,164	Payable to Parents, Subsidiaries and Affiliates	273,203
Other Assets	3,281,527	Other Liabilities	9,434,027
		<b>Total Liabilities</b>	<b>\$ 74,174,300</b>
		<b>POLICYHOLDERS' SURPLUS</b>	
		Capital Stock	3,000,000
		Surplus	28,040,769
		<b>Total Policyholders' Surplus</b>	<b>31,040,769</b>
<b>Total Assets</b>	<b>\$ 105,215,069</b>	<b>Total Liabilities and Policyholders' Surplus</b>	<b>\$ 105,215,069</b>

Bonds and stocks are valued in accordance with the basis adopted by the National Association of Insurance Commissioners (NAIC).

**CERTIFICATE**

The officers of this reporting entity being duly sworn, each depose and say that they are the described officers of said reporting entity, and that on the reporting period stated above, all of the herein described assets were the absolute property of the said reporting entity, free and clear from any liens or claims thereon, except as herein stated; and that this statement, together with related exhibits, schedules and explanations therein contained, annexed or referred to, is a full and true statement of all the assets and liabilities and of the condition and affairs of the said reporting entity as of the reporting period stated above, and of its income and deductions therefrom for the period ended, and have been completed in accordance with the NAIC Annual Statement Instructions and Accounting Practices and Procedures manual except to the extent that: (1) state law may differ; or, (2) that state rules or regulations require differences in reporting not related to accounting practices and procedures, according to the best of their information, knowledge and belief, respectively.

  
 \_\_\_\_\_  
 President

  
 \_\_\_\_\_  
 Assistant Treasurer

State of Georgia  
 County of Fulton

On the 7th day of March, 2006, before me came the above named officers of the American Southern Insurance Company to me personally known to be the individuals and officers described herein, and acknowledge that they executed the foregoing instrument and affixed the seal of said company thereto by authority of their office.

**HELEN L. HILTON**  
 Notary Public, Douglas County, Georgia  
 My Commission Expires Feb 19, 2009

  
 Helen L. Hilton, Notary Public  
 My Commission Expires February 19, 2009