



State of West Virginia  
 Department of Administration  
 Purchasing Division  
 2019 Washington Street East  
 Post Office Box 50130  
 Charleston, WV 25305-0130

# Request for Quotation

RFQ NUMBER:  
**VET07C003**

PAGE:  
**1**

ADDRESS CORRESPONDENCE TO ATTENTION OF:  
**RON PRICE**  
**304-558-0492**

RFQ COPY  
 TYPE NAME/ADDRESS HERE

**Douglas Equipment**  
**301 North Street**  
**Bluefield, WV 24701**  
**(304) 327-0149 1-(800) 962-8618**

SHIP TO

**DIVISION OF VETERANS AFFAIRS**  
**VETERANS NURSING FACILITY**  
  
**ONE FREEDOMS WAY**  
**CLARKSBURG, WV**  
**26301 304-627-2415**

DATE PRINTED	TERMS OF SALE	SHIP VIA	F.O.B.	FREIGHT TERMS
11/13/2006				

BID OPENING DATE: **11/29/2006** BID OPENING TIME **01:30PM**

LINE	QUANTITY	UOP	CAT NO	ITEM NUMBER	UNIT PRICE	AMOUNT
0001	2	EA		740-70	\$ 3857.00	\$ 7714.00
				REFRIGERATOR/FREEZERS		
0002	4	EA		740-70	\$ 2329.00	\$ 9316.00
				REFRIGRATORS		
<p>PROVIDE TWO (2) REFRIGERATOR/FREEZERS TRAUlsen ONE-SECTION REACH-IN MODEL NO. ADT132DUT-HHS: OR EQUAL FOUR (4) REFRIGERATORS TRAUlsen ONE-SECTION MODEL NO. AHT126WUT-FHS OR EQUAL TO THE WV VETERANS NURSING FACILITY, ONE FREEDOMS WAY, CLARKSBURG, WV 26301 PER THE ATTACHED SPECIFICATIONS.</p> <p>THE MODEL/BRAND/SPECIFICATIONS NAMED HEREIN ESTABLISH THE ACCEPTABLE LEVEL OF QUALITY ONLY AND ARE NOT INTENDED TO REFLECT A PREFERENCE OR FAVOR ANY PARTICULAR BRAND OR VENDOR. VENDORS WHO ARE BIDDING ALTERNATES SHOULD SO STATE AND INCLUDE PERTINENT LITERATURE AND SPECIFICATIONS. FAILURE TO PROVIDE INFORMATION FOR ANY ALTERNATES MAY BE GROUNDS FOR REJECTION OF THE BID. THE STATE RESERVES THE RIGHT TO WAIVE MINOR IRREGULARITIES IN BIDS OR SPECIFICATIONS IN ACCORDANCE WITH SECTION 148-1-4(F) OF THE WEST VIRGINIA LEGISLATIVE RULES AND REGULATIONS.</p> <p>VENDOR PREFERENCE CERTIFICATE CERTIFICATION AND APPLICATION* IS HEREBY MADE FOR</p>						

SEE REVERSE SIDE FOR TERMS AND CONDITIONS

SIGNATURE <i>Fay M. Johnson Jr.</i>	TELEPHONE <b>(304) 327-0149</b>	DATE <b>11-22-06</b>
TITLE <b>Bid Specialist</b>	FEIN <b>550585890</b>	ADDRESS CHANGES TO BE NOTED ABOVE

WHEN RESPONDING TO RFQ, INSERT NAME AND ADDRESS IN SPACE ABOVE LABELED 'VENDOR'

**GENERAL TERMS & CONDITIONS  
REQUEST FOR QUOTATION (RFQ) AND REQUEST FOR PROPOSAL (RFP)**

1. Awards will be made in the best interest of the State of West Virginia.
2. The State may accept or reject in part, or in whole, any bid.
3. All quotations are governed by the *West Virginia Code* and the *Legislative Rules* of the Purchasing Division.
4. Prior to any award, the apparent successful vendor must be properly registered with the Purchasing Division and have paid the required \$125.00 registration fee.
5. All services performed or goods delivered under State Purchase Orders/Contracts are to be continued for the term of the Purchase Order/Contract, contingent upon funds being appropriated by the Legislature or otherwise being made available. In the event funds are not appropriated or otherwise available for these services or goods, this Purchase Order/Contract becomes void and of no effect after June 30.
6. Payment may only be made after the delivery and acceptance of goods or services.
7. Interest may be paid for late payment in accordance with the *West Virginia Code*.
8. Vendor preference will be granted upon written request in accordance with the *West Virginia Code*.
9. The State of West Virginia is exempt from federal and state taxes and will not pay or reimburse such taxes.
10. The Director of Purchasing may cancel any Purchase Order/Contract upon 30 days written notice to the seller.
11. The laws of the State of West Virginia and the *Legislative Rules* of the Purchasing Division shall govern all rights and duties under the Contract, including without limitation the validity of this Purchase Order/Contract.
12. Any reference to automatic renewal is hereby deleted. The Contract may be renewed only upon mutual written agreement of the parties.
13. **BANKRUPTCY:** In the event the vendor/contractor files for bankruptcy protection, this contract is automatically null and void, and is terminated without further order.
14. **HIPAA Business Associate Addendum -** The West Virginia State Government HIPAA Business Associate Addendum (BAA), approved by the Attorney General, and available online at the Purchasing Division's web site (<http://www.state.wv.us/admin/purchase/vrc/hipaa.htm>) is hereby made part of the agreement. Provided that, the Agency meets the definition of a Covered Entity (45 CFR §160.103) and will be disclosing Protected Health Information (45 CFR §160.103) to the vendor.

---

**INSTRUCTIONS TO BIDDERS**

1. Use the quotation forms provided by the Purchasing Division.
2. **SPECIFICATIONS:** Items offered must be in compliance with the specifications. Any deviation from the specifications must be clearly indicated by the bidder. Alternates offered by the bidder as **EQUAL** to the specifications must be clearly defined. A bidder offering an alternate should attach complete specifications and literature to the bid. The Purchasing Division may waive minor deviations to specifications.
3. Complete all sections of the quotation form.
4. Unit prices shall prevail in cases of discrepancy.
5. All quotations are considered F.O.B. destination unless alternate shipping terms are clearly identified in the quotation.
6. **BID SUBMISSION:** All quotations must be delivered by the bidder to the office listed below prior to the date and time of the bid opening. Failure of the bidder to deliver the quotations on time will result in bid disqualifications.

**SIGNED BID TO:**

Department of Administration  
Purchasing Division  
2019 Washington Street East  
Post Office Box 50130  
Charleston, WV 25305-0130



State of West Virginia  
 Department of Administration  
 Purchasing Division  
 2019 Washington Street East  
 Post Office Box 50130  
 Charleston, WV 25305-0130

### Request for Quotation

RFQ NUMBER:  
**VET07C003**

PAGE:  
**2**

ADDRESS CORRESPONDENCE TO ATTENTION OF:  
**RON PRICE  
 304-558-0492**

RFQ COPY  
 TYPE NAME/ADDRESS HERE

PROPERTY

**Douglas Equipment  
 301 North Street  
 Bluefield, WV 24701  
 (304) 327-0149 1-(800) 962-8618**

SHIP TO

**DIVISION OF VETERANS AFFAIRS  
 VETERANS NURSING FACILITY  
 ONE FREEDOMS WAY  
 CLARKSBURG, WV  
 26301 304-627-2415**

DATE PRINTED	TERMS OF SALE	SHIP VIA	F.O.B.	FREIGHT TERMS
11/13/2006				

BID OPENING DATE: **11/29/2006** BID OPENING TIME **01:30PM**

LINE	QUANTITY	UOP	CAT. NO.	ITEM NUMBER	UNIT PRICE	AMOUNT
<p>PREFERENCE IN ACCORDANCE WITH WEST VIRGINIA CODE, 5A-3-37 (DOES NOT APPLY TO CONSTRUCTION CONTRACTS).</p> <p>A. APPLICATION IS MADE FOR 2.5% PREFERENCE FOR THE REASON CHECKED:</p> <p>( ) BIDDER IS AN INDIVIDUAL RESIDENT VENDOR AND HAS RESIDED CONTINUOUSLY IN WEST VIRGINIA FOR FOUR (4) YEARS IMMEDIATELY PRECEDING THE DATE OF THIS CERTIFICATION; OR</p> <p>(<input checked="" type="checkbox"/>) BIDDER IS A PARTNERSHIP, ASSOCIATION OR CORPORATION RESIDENT VENDOR AND HAS MAINTAINED ITS HEAD-QUARTERS OR PRINCIPAL PLACE OF BUSINESS CONTINUOUSLY IN WEST VIRGINIA FOR FOUR (4) YEARS IMMEDIATELY PRECEDING THE DATE OF THIS CERTIFICATION; OR 80% OF THE OWNERSHIP INTEREST OF BIDDER IS HELD BY ANOTHER INDIVIDUAL, PARTNERSHIP, ASSOCIATION OR CORPORATION RESIDENT VENDOR WHO HAS MAINTAINED ITS HEADQUARTERS OR PRINCIPAL PLACE OF BUSINESS CONTINUOUSLY IN WEST VIRGINIA FOR FOUR (4) YEARS IMMEDIATELY PRECEDING THE DATE OF THIS CERTIFICATION; OR</p> <p>( ) BIDDER IS A CORPORATION NONRESIDENT VENDOR WHICH HAS AN AFFILIATE OR SUBSIDIARY WHICH EMPLOYS A MINIMUM OF ONE HUNDRED STATE RESIDENTS AND WHICH HAS MAINTAINED ITS HEADQUARTERS OR PRINCIPAL PLACE OF BUSINESS WITHIN WEST VIRGINIA CONTINUOUSLY FOR THE FOUR (4) YEARS IMMEDIATELY PRECEDING THE DATE OF THIS CERTIFICATION.</p> <p>B. APPLICATION IS MADE FOR 2.5% PREFERENCE FOR THE REASON CHECKED:</p> <p>(<input checked="" type="checkbox"/>) BIDDER IS A RESIDENT VENDOR WHO CERTIFIES THAT, DURING THE LIFE OF THE CONTRACT, ON AVERAGE AT LEAST</p>						

SEE REVERSE SIDE FOR TERMS AND CONDITIONS

SIGNATURE <i>Roy M. Ellison Jr.</i>	TELEPHONE <b>(304) 327-0149</b>	DATE <b>11-22-06</b>
TITLE <b>Bid Specialist</b>	FEIN <b>550585890</b>	ADDRESS CHANGES TO BE NOTED ABOVE

WHEN RESPONDING TO RFQ, INSERT NAME AND ADDRESS IN SPACE ABOVE LABELED 'VENDOR'



State of West Virginia  
 Department of Administration  
 Purchasing Division  
 2019 Washington Street East  
 Post Office Box 50130  
 Charleston, WV 25305-0130

# Request for Quotation

RFQ NUMBER  
**VET07C003**

PAGE  
**3**

ADDRESS CORRESPONDENCE TO ATTENTION OF  
**RON PRICE**  
**304-558-0492**

RFQ COPY  
 TYPE NAME/ADDRESS HERE

**Douglas Equipment**  
**301 North Street**  
**Bluefield, WV 24701**  
**(304) 327-0149 1-(800) 962-8618**

**DIVISION OF VETERANS AFFAIRS**  
**VETERANS NURSING FACILITY**

**ONE FREEDOMS WAY**  
**CLARKSBURG, WV**  
**26301 304-627-2415**

DATE PRINTED	TERMS OF SALE	SHIP VIA	FOB	FREIGHT TERMS
11/13/2006				

BID OPENING DATE: **11/29/2006** BID OPENING TIME **01:30PM**

LINE	QUANTITY	UOP	CAT. NO.	ITEM NUMBER	UNIT PRICE	AMOUNT
<p>75% OF THE EMPLOYEES WORKING ON THE PROJECT BEING BID ARE RESIDENTS OF WEST VIRGINIA WHO HAVE RESIDED IN THE STATE CONTINUOUSLY FOR THE TWO YEARS IMMEDIATELY PRECEDING SUBMISSION OF THIS BID;</p> <p>OR</p> <p>( ) BIDDER IS A NONRESIDENT VENDOR EMPLOYING A MINIMUM OF ONE HUNDRED STATE RESIDENTS OR IS A NONRESIDENT VENDOR WITH AN AFFILIATE OR SUBSIDIARY WHICH MAINTAINS ITS HEADQUARTERS OR PRINCIPAL PLACE OF BUSINESS WITHIN WEST VIRGINIA EMPLOYING A MINIMUM OF ONE HUNDRED STATE RESIDENTS WHO CERTIFIES THAT, DURING THE LIFE OF THE CONTRACT, ON AVERAGE AT LEAST 75% OF THE EMPLOYEES OR BIDDERS' AFFILIATE'S OR SUBSIDIARY'S EMPLOYEES ARE RESIDENTS OF WEST VIRGINIA WHO HAVE RESIDED IN THE STATE CONTINUOUSLY FOR THE TWO YEARS IMMEDIATELY PRECEDING SUBMISSION OF THIS BID.</p> <p>BIDDER UNDERSTANDS IF THE SECRETARY OF TAX &amp; REVENUE DETERMINES THAT A BIDDER RECEIVING PREFERENCE HAS FAILED TO CONTINUE TO MEET THE REQUIREMENTS FOR SUCH PREFERENCE, THE SECRETARY MAY ORDER THE DIRECTOR OF PURCHASING TO: (A) RESCIND THE CONTRACT OR PURCHASE ORDER ISSUED; OR (B) ASSESS A PENALTY AGAINST SUCH BIDDER IN AN AMOUNT NOT TO EXCEED 5% OF THE BID AMOUNT AND THAT SUCH PENALTY WILL BE PAID TO THE CONTRACTING AGENCY OR DEDUCTED FROM ANY UNPAID BALANCE ON THE CONTRACT OR PURCHASE ORDER.</p> <p>BY SUBMISSION OF THIS CERTIFICATE, BIDDER AGREES TO DISCLOSE ANY REASONABLY REQUESTED INFORMATION TO THE PURCHASING DIVISION AND AUTHORIZES THE DEPARTMENT OF TAX AND REVENUE TO DISCLOSE TO THE DIRECTOR OF PURCHASING APPROPRIATE INFORMATION VERIFYING THAT BIDDER HAS PAID THE REQUIRED BUSINESS TAXES, PROVIDED THAT SUCH INFORMATION DOES NOT CONTAIN THE AMOUNTS OF TAXES PAID NOR ANY OTHER INFORMATION DEEMED BY THE TAX</p>						

SEE REVERSE SIDE FOR TERMS AND CONDITIONS

SIGNATURE <i>Ray M. Ellison Jr.</i>	TELEPHONE <b>(304) 327-0149</b>	DATE <b>11-22-06</b>
TITLE <b>Bid Specialist</b>	FEN <b>550585890</b>	ADDRESS CHANGES TO BE NOTED ABOVE

WHEN RESPONDING TO RFQ, INSERT NAME AND ADDRESS IN SPACE ABOVE LABELED 'VENDOR'



State of West Virginia  
 Department of Administration  
 Purchasing Division  
 2019 Washington Street East  
 Post Office Box 50130  
 Charleston, WV 25305-0130

# Request for Quotation

RFQ NUMBER  
**VET07C003**

PAGE  
**4**

ADDRESS CORRESPONDENCE TO ATTENTION OF  
**RON PRICE**  
**304-558-0492**

RFQ COPY  
 TYPE NAME/ADDRESS HERE

VENDOR

**Douglas Equipment**  
**301 North Street**  
**Bluefield, WV 24701**  
**(304) 327-0149 1-(800) 962-8618**

SHIP TO

**DIVISION OF VETERANS AFFAIRS**  
**VETERANS NURSING FACILITY**  
**ONE FREEDOMS WAY**  
**CLARKSBURG, WV**  
**26301 304-627-2415**

DATE PRINTED	TERMS OF SALE	SHIP VIA	FOB	FREIGHT TERMS
11/13/2006				

BID OPENING DATE: **11/29/2006** BID OPENING TIME **01:30PM**

LINE	QUANTITY	UQP	CAT. NO.	ITEM NUMBER	UNIT PRICE	AMOUNT
<p>COMMISSIONER TO BE CONFIDENTIAL.</p> <p>UNDER PENALTY OF LAW FOR FALSE SWEARING (WEST VIRGINIA CODE 61-5-3), BIDDER HEREBY CERTIFIES THAT THIS CERTIFICATE IS TRUE AND ACCURATE IN ALL RESPECTS; AND THAT IF A CONTRACT IS ISSUED TO BIDDER AND IF ANYTHING CONTAINED WITHIN THIS CERTIFICATE CHANGES DURING THE TERM OF THE CONTRACT, BIDDER WILL NOTIFY THE PURCHASING DIVISION IN WRITING IMMEDIATELY.</p> <p>BIDDER: <u>Douglas Equipment</u></p> <p>DATE: <u>11-22-2006</u></p> <p>SIGNED: <u>[Signature]</u></p> <p>TITLE: <u>Bid Specialist</u></p> <p>* CHECK ANY COMBINATION OF PREFERENCE CONSIDERATION(S) IN EITHER "A" OR "B", OR BOTH "A" AND "B" WHICH YOU ARE ENTITLED TO RECEIVE. YOU MAY REQUEST UP TO THE MAXIMUM 5% PREFERENCE FOR BOTH "A" AND "B". (REV. 12/00)</p> <p>NOTICE</p> <p>A SIGNED BID MUST BE SUBMITTED TO:</p> <p>DEPARTMENT OF ADMINISTRATION          PURCHASING DIVISION          BUILDING 15          2019 WASHINGTON STREET, EAST          CHARLESTON, WV 25305-0130</p>						

SEE REVERSE SIDE FOR TERMS AND CONDITIONS

SIGNATURE <u>[Signature]</u>	TELEPHONE <u>(304) 327-0149</u>	DATE <u>11-22-06</u>
TITLE <u>Bid Specialist</u>	FEIN <u>550585890</u>	ADDRESS CHANGES TO BE NOTED ABOVE

WHEN RESPONDING TO RFQ, INSERT NAME AND ADDRESS IN SPACE ABOVE LABELED 'VENDOR'



State of West Virginia  
 Department of Administration  
 Purchasing Division  
 2019 Washington Street East  
 Post Office Box 50130  
 Charleston, WV 25305-0130

# Request for Quotation

RFQ NUMBER  
**VET07C003**

PAGE  
**5**

ADDRESS CORRESPONDENCE TO ATTENTION OF  
**RON PRICE**  
**304-558-0492**

RFQ COPY  
 TYPE NAME/ADDRESS HERE

**Douglas Equipment**  
**301 North Street**  
**Bluefield, WV 24701**  
**(304) 327-0149 1-(800) 962-8618**

**DIVISION OF VETERANS AFFAIRS**  
**VETERANS NURSING FACILITY**

**ONE FREEDOMS WAY**  
**CLARKSBURG, WV**  
**26301 304-627-2415**

DATE PRINTED:	TERMS OF SALE	SHIP VIA	F.O.B.	FREIGHT TERMS
11/13/2006				

BID OPENING DATE: **11/29/2006** BID OPENING TIME **01:30PM**

LINE	QUANTITY	UOP	CAT. NO.	ITEM NUMBER	UNIT PRICE	AMOUNT
<p>THE BID SHOULD CONTAIN THIS INFORMATION ON THE FACE OF THE ENVELOPE OR THE BID MAY NOT BE CONSIDERED:</p> <p>SEALED BID</p> <p>BUYER: 41</p> <p>RFQ. NO.: VET07C003</p> <p>BID OPENING DATE: 11/29/2006</p> <p>BID OPENING TIME: 1:30 PM</p> <p>PLEASE PROVIDE A FAX NUMBER IN CASE IT IS NECESSARY TO CONTACT YOU REGARDING YOUR BID:            (304) 325-3848</p> <p>CONTACT PERSON (PLEASE PRINT CLEARLY):            Roy M. Ellison Jr.</p> <p>***** THIS IS THE END OF RFQ VET07C003 ***** TOTAL: <b>\$ 17,030.00</b></p>						

SEE REVERSE SIDE FOR TERMS AND CONDITIONS

SIGNATURE <i>Roy M. Ellison Jr.</i>	TELEPHONE <b>(304) 327-0149</b>	DATE <b>11-22-06</b>
TITLE <b>Bio Specialist</b>	FEIN <b>550585890</b>	ADDRESS CHANGES TO BE NOTED ABOVE

WHEN RESPONDING TO RFQ, INSERT NAME AND ADDRESS IN SPACE ABOVE LABELED 'VENDOR'

**SPECIFICATIONS**

**2 each**                    **REFRIGERATOR/FREEZER** shall be the following or approved equal:

1. Traulsen One-Section Reach-In Refrigerator/Freezer Model No. ADT132DUT-HHS.

Project Description:

- a. 24w, 3"d and 83 ½"H
- b. Type 304 stainless steel exterior and anodized aluminum interior.
- c. Two half-height right-hinged doors with lockable door latches.
- d. 5" non-swivel rear casters and 5" swivel front casters with locks
- e. Two chrome plated rack shelves in each chamber.

All standard characteristics of this model number shall apply except as modified by items d and e above.

Regulatory Listings shall include NSF, and UL

LOCATION: One for each Dining Room Pantry (C141 and C241).

INSTALLATION: The items and devices shall be furnished ready for installation by Owner.

**4 each**                    **REFRIGERATOR** shall be the following or approved equal:

2. Traulsen One-Section Refrigerator  
Model No. AHT126WUT-FHS.

Units shall have type 304 stainless steel exteriors and door fronts, with aluminum interiors.

Units shall have Full-Door with lock, three shelves and adjustable NSF feet.

LOCATION: One for each Med. Room (C105, C206, C271) and one in the Alzheimer Nurse Station (B160A).

WARRANTY: All shall be covered by the manufacturer's standard warranty for a period of not less than one year, a copy of which shall be provided to the facility.

**SCHEDULE:**

The schedule for receipt of these items shall be no earlier than 1 December 2006 and no later than 15 January 2007, and further shall be subject to a specific delivery date and on-site location established with the administrator of the Nursing Home or his designee. Items capable of being shipped by USPS, FedEx, UPS or other common carrier shall be so stated in the vendor's proposal. The address to be used will be stated in the notification of acceptance. All shipping charges, insurance and/or postage shall be included in the Seller's proposal and prepaid by the Vendor.

The Vendor shall send to the Nursing Home 30 days in advance of scheduled delivery, confirmation of the time and place of delivery, pre-delivery check lists, service manuals, product user manuals and in-service training aids as required. At that time, pre-delivery meeting will be scheduled if needed.

Pre-delivery meeting(s) will visit and confirm the drop-off point and the date of delivery of these items any other clarification required.

**\* NOTE \***

Items capable of being shipped via common carrier. Pricing includes freight with liftgate service (if required).

11/22/2006

**Quotation**

**To:** RFQ Number-VET07C003  
 Division of Veterans Affairs  
 Veterans Nursing Facility  
 One Freedoms Way  
 Clarksburg, WV 26301

**From:** Douglas Equipment  
 Roy Ellison  
 301 North St.  
 Bluefield, WV 24701-4048

Phone: (304) 327-0149

Item	Qty	Description	Sell Each	Sell Total
1	2	ea <b>REFRIGERATOR/FREEZER, REACH-IN</b> Continental Refrigerator Model No. 1RF-SA-HD Refrigerator/Freezer, reach-in, one-section, self-contained refig system, stainless steel exterior, aluminum interior, standard depth cabinet, narrow half-height doors, with exterior dial-type thermometer, 5" casters, dual 1/5 & 1/4 HP	3,857.00	7,714.00
	2	ea 115v/60/1, (2) cord & plugs, std.		
	2	ea Standard warranty: 1 year parts and labor; 5 year compressor		
	2	ea Door hinged on right, std.		
	2	ea Shelf, chrome plated wire w/clips Weight: 920 lbs. total		
2	4	ea <b>REFRIGERATOR, REACH-IN</b> Continental Refrigerator Model No. 1R-SA Refrigerator, reach-in, one-section, self-contained refig system, stainless steel exterior, aluminum interior, standard depth cabinet, narrow full-height door, with exterior dial-type thermometer, 5" casters, 1/4 hp	2,329.00	9,316.00
	4	ea 115v/60/1, cord & plug std,		
	4	ea Standard warranty: 1 year parts and labor; 5 year compressor		
	4	ea Shallow depths, contact factory		
	4	ea Door hinged on right, std.		
	4	ea Thermometer digital remote reading, external mounted		
	4	ea Legs, 6" s/s, set of 4 Weight: 1400 lbs. total		
**PRICING INCLUDES DROP SHIP DELIVERY VIA COMMON CARRIER WITH LIFT GATE SERVICE IF REQUIRED.**				
			Total	17,030.00
			Grand Total	17,030.00

# Continental

## Refrigerator

*Designer Line*  
REFRIGERATOR/FREEZER

### OVER/UNDER DUAL TEMP REFRIGERATOR/FREEZER

Utilizing Environmentally Safe, CFC-free R-134a/ R-404a Refrigerant

#### Standard Features

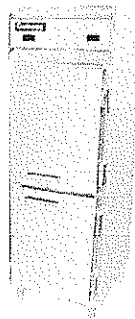

DL1RF-SS



DL1RFE-SS

- Modern, State-of-the-Art Styling
- Performance Rated Refrigeration Systems
- 3" Non-CFC Polyurethane Foam Insulation
- Chrome Plated Flow Line Handles
- Cam-Action Lift-Off Hinges
- Self-Closing Doors
- Magnetic Snap-In Door Gaskets
- Cylinder Lock In Each Door
- Automatic Electric Condensate Evaporator
- Adjustable 6" Stainless Steel Legs
- Heavy-Duty, Epoxy-Coated Steel Shelves
- External Digital Thermometers
- Automatic Electric Defrost On Freezer Systems
- Automatic Interior Lighting

#### Models Available

- Remote
- Hinged Glass Door
- Consult Factory

#### OTHER MODELS AVAILABLE

- DL1RFX-SS

Standard (S/S Front, Aluminum Ends & Interior)  
Suffix SA (S/S Exterior, Aluminum Interior)  
Suffix SS (S/S Exterior & Interior)

#### Refrigeration System

Two "performance rated", air cooled, hermetically sealed, capillary-type refrigeration systems are installed on the top of each dual temp. Plasticized fin coil and air circulating fans are contained within an easily accessible, low-profile, interior ceiling mounted housing. Both refrigeration systems are fully charged with refrigerant and evenly matched providing equal air distribution. Refrigerator sections are designed to maintain 38-40 degrees Fahrenheit (3 to 5 degrees Centigrade), and Freezer sections 0 degrees Fahrenheit (-18 degrees Centigrade) while operating with an unrestricted air supply in a maximum ambient temperature of 100 degrees Fahrenheit. Freezer systems have an automatic electric defrost timer which initiates defrost cycles at pre-determined intervals. All condensate water is directed to the cabinet bottom for connection to an automatic thermostatically controlled evaporator which is supplied with each model. A strict quality-assurance team inspects all materials and components to certify that each model conforms to the most exacting standards. All models are factory performance tested for a minimum of 16 hours prior to crating.

#### Cabinet Construction

All materials are of top quality, assembled to conform with strict quality-assurance requirements. The cabinet front and doors are constructed of heavy-gauge polished stainless steel for durability. All cabinet joints and seams are sealed vapor tight. Case is of all metal, welded construction and internally supported and braced for a rigid unit construction. Cabinet design eliminates overlapping panels with raw edges. Cabinet body, and doors are insulated with non-CFC, foamed-in-place polyurethane foam with an average thickness of 3 inches to ensure increased energy efficiency. Full length louvered air grille located above the doors allows equal air circulation to the condensing units. Easily removable, low wattage, anti-sweat door heaters concealed by a non-metallic, non-conductive, high-impact thermal breaker strip eliminate condensate build up on the cabinet front. Automatic interior lighting is controlled by door openings. Cabinets are equipped with 6-inch adjustable stainless steel legs.

#### Shelving

Shelves are designed for heavy-duty use with .306" diameter frame and brace members and .140" diameter fill wires spaced 3/4" apart. Shelves are welded steel and epoxy-coated for a durable, long, rust-free service life. Adjustments are in 1/2 inch increments and a wide door opening allows the use of a variety of optional pan and tray slide types.

#### Door Construction

Door shells are constructed of heavy-gauge stainless steel and are internally braced and urethane-foam-insulated for rigidity. Door corners are of welded construction and polished. Replaceable snap-in door gaskets are self-adjusting, heavy-duty, magnetic type. Door handles and hinges are chrome-plated and non-corrosive. Doors are provided with built-in cylinder locks which are keyed alike. Hinges are cam-action, lift-off type featuring positive safety stop at 120 degrees.





**REFRIGERATOR/FREEZER**

	MODEL DL1RF-SS ONE SECTION Reach-In	MODEL DL1RFX-SS ONE SECTION Reach-In	MODEL DL1RFE-SS ONE SECTION Reach-In
--	---	--	--

**CHARACTERISTICS**

**DIMENSIONAL DATA**

Net Capacity (cu. ft.) Refrigerator	10	16	11
Net Capacity (cu.ft.) Freezer	10	16	11
Width, Overall (in.)	26	36 <sup>1</sup> / <sub>4</sub>	28 <sup>1</sup> / <sub>2</sub>
Depth, Overall (Incl. Hdls.) (in.)	35 <sup>1</sup> / <sub>2</sub>	35 <sup>1</sup> / <sub>2</sub>	35 <sup>1</sup> / <sub>2</sub>
Depth (Less Door(s) (in.)	32	32	32
Depth (Doors(s) Open 90°) (in.)	55 <sup>1</sup> / <sub>2</sub>	66	58
Clear Door Width (in.)	19 <sup>9</sup> / <sub>8</sub>	29 <sup>9</sup> / <sub>8</sub>	21 <sup>7</sup> / <sub>8</sub>
Clear Half-Door Height (in.)	27 <sup>1</sup> / <sub>2</sub>	27 <sup>1</sup> / <sub>2</sub>	27 <sup>1</sup> / <sub>2</sub>
Height, Overall (Incl. 6" Legs)(in.)	83 <sup>1</sup> / <sub>4</sub>	83 <sup>1</sup> / <sub>4</sub>	83 <sup>1</sup> / <sub>4</sub>
Half Doors	2	2	2
Shelves	4	4	4
Shelf Area (sq. ft.)	10.2	24.4	10.2
Tray Slide Capacity (Half)	11ea.	11ea.	11ea.

**REFRIGERATION DATA**

Condensing Unit Size (H.P.) Ref.	1/5	1/4	1/5
Condensing Unit Size (H.P.) Frz.	1/4	1/3	1/4
Capacity (BTU/hr)*Ref.	1725	1940	1725
Capacity (BTU/hr)*Frz.	1250	1590	1250

**ELECTRICAL DATA**

Cabinet Specifications	115/60/1	115/60/1	115/60/1
Feed Wires (Incl. Ground)	3/3	3/3	3/3
Condensing Unit Specs.	115/60/1	115/60/1	115/60/1
Total Amperes	5.3/5.4	6.9/7.6	5.3/5.4
Cabinet Amperes	.9/1.9	1.6/1.6	.9/1.9
Defrost Amperes	5.2	6.5	5.2
Power Supply Cord	yes/yes	yes/yes	yes/yes

**SHIPPING DATA**

Height – crated (in.)	85 <sup>1</sup> / <sub>2</sub>	85 <sup>1</sup> / <sub>2</sub>	85 <sup>1</sup> / <sub>2</sub>
Width – crated (in.)	31 <sup>5</sup> / <sub>8</sub>	42	31 <sup>5</sup> / <sub>8</sub>
Depth – crated (in.)	42	42	42
Volume – crated (cu.ft.)	66	87	66
Weight Std – crated (lbs.)	420	440	420
Weight SS – crated (lbs.)	480	500	480
Weight Std – uncrated (lbs.)	320	340	320
Weight SS – uncrated (lbs.)	380	400	380

\*Rating @ +25° F Evaporator, 90° Ambient (Refrigerator)

\*Rating @ -15° F Evaporator, 90° Ambient (Freezer)

Note: All specifications subject to change without notice

Note: If the cabinet is located directly against wall and/or under low ceiling, a minimum clearance of 2" is required.

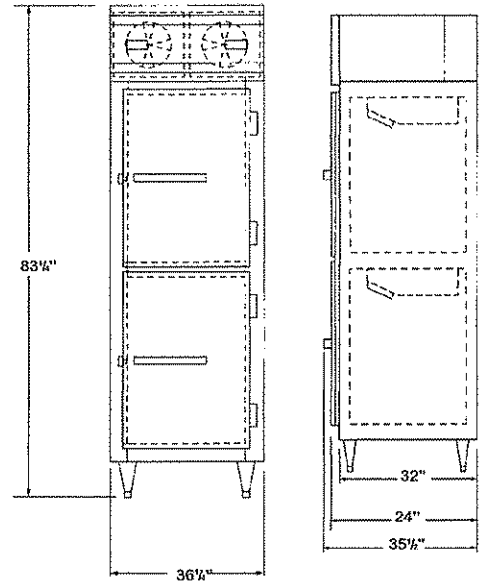

**DL1RFX-SS  
FRONT VIEW**

**SIDE VIEW**

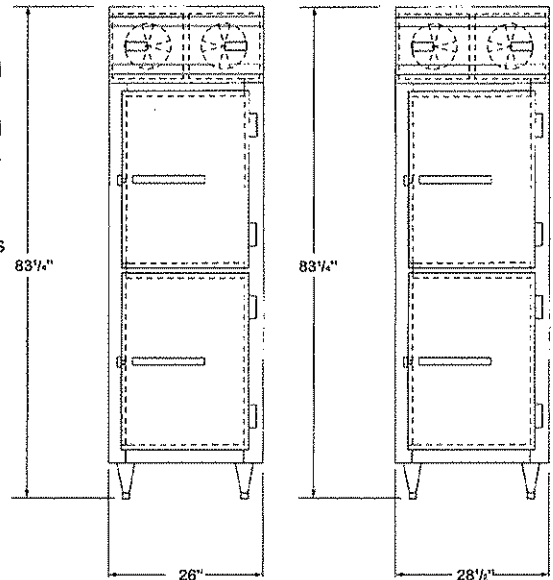

**DL1RF-SS  
FRONT VIEW**

**DL1RFE-SS  
FRONT VIEW**



A Division of National Refrigeration & A/C Products, Inc.  
539 Dunksferry Road Bensalem, PA 19020  
(800) 523-7138 Fax: (215) 244-9579  
www.continentalrefrigerator.com

# Continental



Refrigerator

**REACH-IN  
REFRIGERATORS**

Utilizing Environmentally Safe, CFC-free R-134a Refrigerant

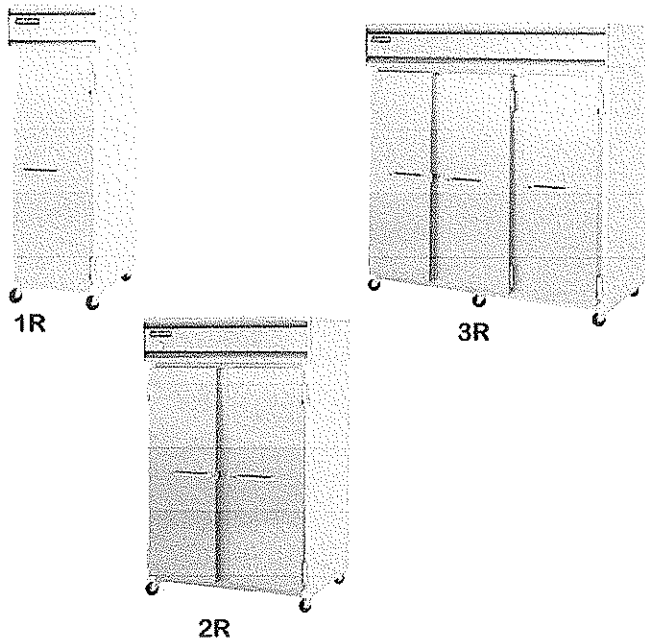

## Standard Features

- Modern, State-of-the-Art Styling
- Performance Rated Refrigeration System Utilizing Environmentally Safe R-134a Refrigerant
- 3" Non-CFC Polyurethane Foam Insulation
- Chrome Plated Flow Line Handles
- Cam-Action Lift-Off Hinges
- Self-Closing Doors
- Automatic Interior Lighting
- Magnetic Snap-In Door Gasket
- Cylinder Lock in Each Door
- Automatic Electric Condensate Evaporator
- 5" Casters
- Heavy-Duty, Epoxy-Coated Steel Shelves
- External Dial Thermometer

Standard (S/S Front, Aluminum End Panels & Interior)

Suffix SA (S/S Exterior, Aluminum Interior)

Suffix SS (S/S Exterior & Interior)

## Optional Features & Accessories

- Stainless Steel Case Back
- Pan Slide Assemblies
- Increased Refrigeration Systems
- Stainless Steel Shelves
- Digital Thermometer
- Rehinging of Doors
- Legs
- Half Door
- Pass-Thru
- Remote
- Shallow Depth
- Hinged Glass Doors

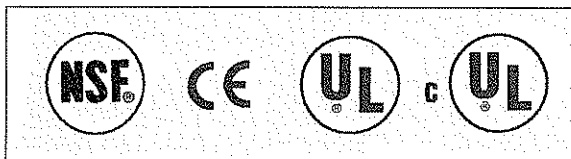



**REFRIGERATORS**

SPECIFICATIONS	1R		2R		3R	
	One Section		Two Section		Three Section	
CHARACTERISTICS	Reach-In	Pass-Thru	Reach-In	Pass-Thru	Reach-In	Pass-Thru
<b>DIMENSIONAL DATA</b>						
Net Capacity (cu. ft.)	20	20	48	48	70	70
Width, Overall (in.)	26	26	52	52	78	78
Depth, Overall (Incl. Hdl.) (in.)	35 1/2	39	35 1/2	39	35 1/2	39
Depth (Less Door(s)) (in.)	32	32	32	32	32	32
Depth (Doors(s) Open 90°) (in.)	55 1/2	79	55 1/2	79	55 1/2	79
Clear Door Width (in.)	19 3/8	19 3/8	19 3/8	19 3/8	19 3/8	19 3/8
Clear Full-Door Height (in.)	58 5/8	58 5/8	58 5/8	58 5/8	58 5/8	58 5/8
Clear Half-Door Height (in.)	27 1/2	27 1/2	27 1/2	27 1/2	27 1/2	27 1/2
Height, Overall (Inc. 5" Casters)(in.)	82 1/4	82 1/4	82 1/4	82 1/4	82 1/4	82 1/4
No. of Full Door(s)	1	2	2	4	3	6
No. of Half Door(s)	2	4	4	8	6	12
No. of Shelves	3	3	6	6	9	9
Shelf Area (sq. ft.)	20.4	20.4	40.8	40.8	61.2	61.2
Tray Slide Capacity (Half)	11 ea.	11 ea.	11 ea.	11 ea.	11 ea.	11 ea.
Tray Slide Capacity (Full)	24 ea.	24 ea.	24 ea.	24 ea.	24 ea.	24 ea.
<b>REFRIGERATION DATA</b>						
Condensing Unit Size (H.P.)	1/4	1/4	1/3	1/3	1/2	1/2
Capacity (BTU/Hr)*	1940	1940	2560	2560	4010	4010
<b>ELECTRICAL DATA</b>						
Cabinet Specifications	115/60/1	115/60/1	115/60/1	115/60/1	115/60/1	115/60/1
Feed Wires (Incl. Ground)	3	3	3	3	3	3
Condensing Unit Specs.	115/60/1	115/60/1	115/60/1	115/60/1	115/60/1	115/60/1
Total Amperes	6.9	7.2	9.1	9.8	12.0	13.0
Cabinet Amperes	1.6	1.9	1.9	2.6	2.9	3.9
Defrost Amperes	-	-	-	-	-	-
Power Supply Cord	yes	yes	yes	yes	yes	yes
<b>SHIPPING DATA</b>						
Height – crated (in.)	85 1/2	85 1/2	85 1/2	85 1/2	85 1/2	85 1/2
Width – crated (in.)	31 3/8	31 3/8	64	64	90	90
Depth – crated (in.)	42	42	42	42	42	42
Volume – crated (cu.ft.)	65	65	133	133	187	187
Weight Std – crated (lbs.)	310	340	520	580	725	815
Weight SS – crated (lbs.)	370	400	600	660	840	930
Weight Std – uncrated (lbs.)	210	240	350	410	515	600
Weight SS – uncrated (lbs.)	270	300	430	490	630	720

\* Rating @ +25°F Evaporator, 90° Ambient

Note: All specifications subject to change without notice.

Note: If the cabinet is located directly against wall and/or under low ceiling, a minimum clearance of 2" is required.

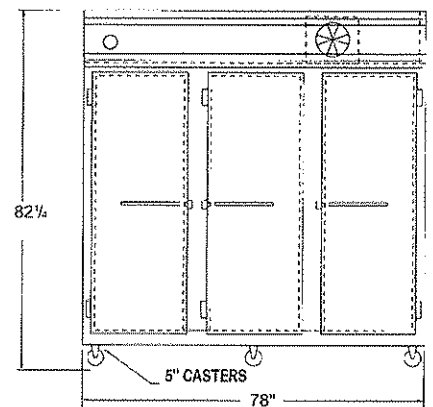
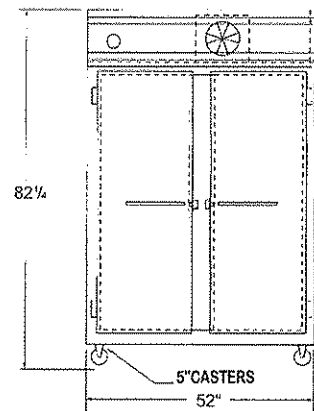
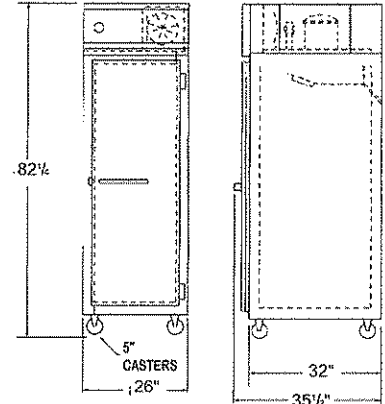

A Division of National Refrigeration & A/C Products, Inc.  
 539 Dunksferry Road Bensalem, PA 19020  
 (800) 523-7138 Fax: (215) 244-9579  
 www.continentalrefrigerator.com

# AFFIDAVIT

**West Virginia Code §5A-3-10a states:**

No contract or renewal of any contract may be awarded by the state or any of its political subdivisions to any vendor or prospective vendor when the vendor or prospective vendor or a related party to the vendor or prospective vendor is a debtor and the debt owned is an amount greater than one thousand dollars in the aggregate

**DEFINITIONS:**

"Debt" means any assessment, premium, penalty, fine, tax or other amount of money owed to the state or any of its political subdivisions because of a judgment, fine, permit violation, license assessment, defaulted workers' compensation premium, penalty or other assessment presently delinquent or due and required to be paid to the state or any of its political subdivisions, including any interest or additional penalties accrued thereon.

"Debtor" means any individual, corporation, partnership, association, limited liability company or any other form or business association owing a debt to the state or any of its political subdivisions. "Political subdivision" means any county commission; municipality; county board of education; any instrumentality established by a county or municipality; any separate corporation or instrumentality established by one or more counties or municipalities, as permitted by law; or any public body charged by law with the performance of a government function or whose jurisdiction is coextensive with one or more counties or municipalities. "Related party" means a party, whether an individual, corporation, partnership, association, limited liability company or any other form or business association or other entity whatsoever, related to any vendor by blood, marriage, ownership or contract through which the party has a relationship of ownership or other interest with the vendor so that the party will actually or by effect receive or control a portion of the benefit, profit or other consideration from performance of a vendor contract with the party receiving an amount that meets or exceed five percent of the total contract amount.

**EXCEPTION:**

The prohibition of this section does not apply where a vendor has contested any tax administered pursuant to chapter eleven of this code, workers' compensation premium, permit fee or environmental fee or assessment and the matter has not become final or where the vendor has entered into a payment plan or agreement and the vendor is not in default of any of the provisions of such plan or agreement.

**LICENSING:**

Vendors must be licensed and in good standing in accordance with any and all state and local laws and requirements by any state or local agency of West Virginia, including, but not limited to, the West Virginia Secretary of State's Office, the West Virginia Tax Department, West Virginia Insurance Commission, or any other state agencies or political subdivision. Furthermore, the vendor must provide all necessary releases to obtain information to enable the Director or spending unit to verify that the vendor is licensed and in good standing with the above entities.

**CONFIDENTIALITY:**

The vendor agrees that he or she will not disclose to anyone, directly or indirectly, any such personally identifiable information or other confidential information gained from the agency, unless the individual who is the subject of the information consents to the disclosure in writing or the disclosure is made pursuant to the agency's policies, procedures and rules. Vendors should visit [www.state.wv.us/admin/purchase/privacy](http://www.state.wv.us/admin/purchase/privacy) for the Notice of Agency Confidentiality Policies.

Under penalty of law for false swearing (West Virginia Code, §61-5-3), it is hereby certified that the vendor acknowledges the information in this said affidavit and are in compliance with the requirements as stated.

Vendor's Name: DOUGLAS EQUIPMENT

Authorized Signature: [Signature] Date: 11-22-06