



State of West Virginia
 Department of Administration
 Purchasing Division
 2019 Washington Street East
 Post Office Box 50130
 Charleston, WV 25305-0130

Request for Quotation

RFQ NUMBER
SYSFURN07

PAGE
1

ADDRESS CORRESPONDENCE TO ATTENTION OF:
BETTY FRANCISCO
304-558-0468

VENDOR

*709055848 304-340-4288
 ACCESS SYSTEMS
 4108 MACCORKLE AVENUE SE
 CHARLESTON WV 25304

SHIP TO

ALL STATE AGENCIES
 AND POLITICAL SUBDIVISIONS
 VARIOUS LOCALES AS INDICATED
 BY ORDER

DATE PRINTED	TERMS OF SALE	SHIP VIA	F.O.B.	FREIGHT TERMS
07/27/2006				
BID OPENING DATE: 09/06/2006		BID OPENING TIME 01:30PM		

LINE	QUANTITY	UOP	CAT NO.	ITEM NUMBER	UNIT PRICE	AMOUNT
REQUEST FOR QUOTATION						
THE PURCHASING DIVISION IS SOLICITING BIDS FOR A BLANKET OPEN-END STATEWIDE CONTRACT FOR SYSTEMS FURNITURE AND ALL OTHER TYPES OF OFFICE FURNITURE.						
*****NOTICE*****						
THERE IS A MANDATORY PRE-BID MEETING SCHEDULED FOR WEDNESDAY, AUGUST 16, 2006 AT 11:00 A.M. IN THE PURCHASING DIVISION CONFERENCE ROOM LOCATED IN BUILDING 15, 2019 WASHINGTON STREET, EAST, CHARLESTON, WEST VIRGINIA. ONLY VENDORS REPRESENTED AT THIS MEETING SHALL BE ELIGIBLE TO SUBMIT BIDS. FAILURE TO ATTEND THE MANDATORY PRE-BID CONFERENCE SHALL AUTOMATICALLY DISQUALIFY A VENDOR FROM BIDDING ON THIS CONTRACT. NO ONE PERSON CAN REPRESENT MORE THAN ONE BIDDER.						
ATTACHMENTS:						
1. SPECIFICATIONS, 18 PAGES, DATED REV. 7/18/2006						
2. EXHIBIT A - VENDORS MUST USE THIS EXHIBIT TO LIST ALL CATALOGS BEING BID AND THE DISCOUNT FOR EACH. VENDORS SHOULD COMPLETE ALL INFORMATION REQUESTED. THE DESIGN FEE AND LABOR RATE FOR ANY REARRANGEMENT MUST BE SHOWN. THESE RATES CANNOT EXCEED \$30.00/HOUR.						
3. CERTIFICATION PAGE - SHOULD BE SIGNED AND RETURNED WITH BID. NO AWARD WILL BE DONE WITHOUT THIS CERTIFICATION.						
4. AFFIDAVIT - SHOULD BE SIGNED AND RETURNED WITH BID. NO AWARD WILL BE MADE WITHOUT THIS AFFIDAVIT.						

SIGNATURE	SEE REVERSE SIDE FOR TERMS AND CONDITIONS		TELEPHONE	DATE
<i>Roberto L. Burnett</i>			340-4288	9/20/06
TITLE	FEEIN	ADDRESS CHANGES TO BE NOTED ABOVE		
President	55-068-4486			

WHEN RESPONDING TO RFQ, INSERT NAME AND ADDRESS IN SPACE ABOVE LABELED 'VENDOR'

**GENERAL TERMS & CONDITIONS
REQUEST FOR QUOTATION (RFQ) AND REQUEST FOR PROPOSAL (RFP)**

1. Awards will be made in the best interest of the State of West Virginia.
2. The State may accept or reject in part, or in whole, any bid.
3. All quotations are governed by the *West Virginia Code* and the *Legislative Rules* of the Purchasing Division.
4. Prior to any award, the apparent successful vendor must be properly registered with the Purchasing Division and have paid the required \$125.00 registration fee.
5. All services performed or goods delivered under State Purchase Orders/Contracts are to be continued for the term of the Purchase Order/Contract, contingent upon funds being appropriated by the Legislature or otherwise being made available. In the event funds are not appropriated or otherwise available for these services or goods, this Purchase Order/Contract becomes void and of no effect after June 30.
6. Payment may only be made after the delivery and acceptance of goods or services.
7. Interest may be paid for late payment in accordance with the *West Virginia Code*.
8. Vendor preference will be granted upon written request in accordance with the *West Virginia Code*.
9. The State of West Virginia is exempt from federal and state taxes and will not pay or reimburse such taxes.
10. The Director of Purchasing may cancel any Purchase Order/Contract upon 30 days written notice to the seller.
11. The laws of the State of West Virginia and the *Legislative Rules* of the Purchasing Division shall govern all rights and duties under the Contract, including without limitation the validity of this Purchase Order/Contract.
12. Any reference to automatic renewal is hereby deleted. The Contract may be renewed only upon mutual written agreement of the parties.
13. **BANKRUPTCY:** In the event the vendor/contractor files for bankruptcy protection, this contract is automatically null and void, and is terminated without further order.
14. **HIPAA Business Associate Addendum** - The West Virginia State Government HIPAA Business Associate Addendum (BAA), approved by the Attorney General, and available online at the Purchasing Division's web site (<http://www.state.wv.us/admin/purchase/vrc/hipaa.htm>) is hereby made part of the agreement. Provided that, the Agency meets the definition of a Covered Entity (45 CFR §160.103) and will be disclosing Protected Health Information (45 CFR §160.103) to the vendor.

INSTRUCTIONS TO BIDDERS

1. Use the quotation forms provided by the Purchasing Division.
2. **SPECIFICATIONS:** Items offered must be in compliance with the specifications. Any deviation from the specifications must be clearly indicated by the bidder. Alternates offered by the bidder as **EQUAL** to the specifications must be clearly defined. A bidder offering an alternate should attach complete specifications and literature to the bid. The Purchasing Division may waive minor deviations to specifications.
3. Complete all sections of the quotation form.
4. Unit prices shall prevail in cases of discrepancy.
5. All quotations are considered F.O.B. destination unless alternate shipping terms are clearly identified in the quotation.
6. **BID SUBMISSION:** All quotations must be delivered by the bidder to the office listed below prior to the date and time of the bid opening. Failure of the bidder to deliver the quotations on time will result in bid disqualifications.

SIGNED BID TO:

Department of Administration
Purchasing Division
2019 Washington Street East
Post Office Box 50130
Charleston, WV 25305-0130



State of West Virginia
 Department of Administration
 Purchasing Division
 2019 Washington Street East
 Post Office Box 50130
 Charleston, WV 25305-0130

Request for Quotation

RFQ NUMBER
SYSFURN07

PAGE
2

ADDRESS: CORRESPONDENCE TO ATTENTION OF:
BETTY FRANCISCO 304-558-0468

VENDOR

*709055848 304-340-4288
 ACCESS SYSTEMS
 4108 MACCORKLE AVENUE SE
 CHARLESTON WV 25304

SHIP TO

ALL STATE AGENCIES
 AND POLITICAL SUBDIVISIONS
 VARIOUS LOCALES AS INDICATED
 BY ORDER

DATE PRINTED	TERMS OF SALE	SHIP VIA	F.O.B.	FREIGHT TERMS
07/27/2006				

BID OPENING DATE: **09/06/2006** BID OPENING TIME **01:30PM**

LINE	QUANTITY	UOP	CAT NO	ITEM NUMBER	UNIT PRICE	AMOUNT
0001	1	JB		425-94		
OFFICE FURNITURE, PANEL SYSTEMS, CHAIRS, ETC.						
<p>THIS IS TO PROVIDE FURNITURE TO ALL STATE AGENCIES AND POLITICAL SUBDIVISIONS. THE STATE OF WEST VIRGINIA DEPARTMENT OF CORRECTIONS IS AUTHORIZED TO FURNISH AND SUPPLY OFFICE FURNITURE TO THE STATE AGENCIES. IT IS NOT THE INTENT OF THIS CONTRACT TO SUPERCEDE THE RIGHTS OF THE DEPARTMENT OF CORRECTIONS. ALL STATE AGENCIES ARE TO CONTACT THE WV DEPARTMENT OF CORRECTIONS, PRISON INDUSTRIES TO DETERMINE IF THE SAME OR SIMILAR ITEM IS AVAILABLE FROM THE DEPARTMENT OF CORRECTIONS.</p> <p>THE DISCOUNT PRICES INCLUDE DELIVERY AND INSTALLATION. ALL ITEMS ARE TO BE FULLY ASSEMBLED AND INSTALLED ON-SITE IN THE LOCATION DETERMINED BY THE AGENCY. THE VENDOR SHALL CHECK FOR DAMAGE, CLEAN AND ADJUST ALL FURNITURE SYSTEMS, AND MUST REMOVE ALL DEBRIS FROM THE PREMISES. ANY ITEM FOUND TO BE DAMAGED OR OTHERWISE UNACCEPTABLE SHALL BE REPAIRED OR REPLACED TO THE SATISFACTION OF THE AGENCY. DEBRIS AND PACKING MATERIALS ARE TO BE PROPERLY DISPOSED OF BY THE VENDOR AT ITS EXPENSE AND SHALL NOT BE LEFT AT THE JOB SITE.</p> <p>ALL EQUIPMENT FURNISHED IN CONJUNCTION WITH THIS CONTRACT SHALL BE NEW. REFURBISHED AND/OR REFINISHED EQUIPMENT SHALL NOT BE ACCEPTABLE. AN INSTALLATION SHALL BE TAKEN TO MEAN ALL COMPONENTS, TOOLS, HARDWARE, LABOR, ETC. NECESSARY TO PROVIDE A COMPLETE INSTALLATION.</p>						

SEE REVERSE SIDE FOR TERMS AND CONDITIONS

SIGNATURE	TELEPHONE	DATE
<i>Robert L Burnett</i>	340-4288	9/20/06
TITLE	FEIN	ADDRESS CHANGES TO BE NOTED ABOVE
President	55-068-4486	

WHEN RESPONDING TO RFQ, INSERT NAME AND ADDRESS IN SPACE ABOVE LABELED 'VENDOR'



State of West Virginia
 Department of Administration
 Purchasing Division
 2019 Washington Street East
 Post Office Box 50130
 Charleston, WV 25305-0130

Request for Quotation

RFQ NUMBER
SYSFURN07

PAGE
4

ADDRESS CORRESPONDENCE TO ATTENTION OF:
BETTY FRANCISCO 304-558-0468

VENDOR

*709055848 304-340-4288
 ACCESS SYSTEMS
 4108 MACCORKLE AVENUE SE
 CHARLESTON WV 25304

SHIP TO

ALL STATE AGENCIES
 AND POLITICAL SUBDIVISIONS
 VARIOUS LOCALES AS INDICATED
 BY ORDER

DATE PRINTED	TERMS OF SALE	SHIP VIA	F.O.B.	FREIGHT TERMS
07/27/2006				

BID OPENING DATE: **09/06/2006** **BID OPENING TIME 01:30PM**

LINE	QUANTITY	UOP	CAT NO.	ITEM NUMBER	UNIT PRICE	AMOUNT
<p>IMMEDIATE DELIVERY IN EMERGENCIES DUE TO UNFORESEEN CAUSES (INCLUDING BUT NOT LIMITED TO DELAYS IN TRANSPORTATION OR AN UNANTICIPATED INCREASE IN THE VOLUME OF WORK.)</p> <p>QUANTITIES: QUANTITIES LISTED IN THE REQUISITION ARE APPROXIMATIONS ONLY, BASED ON ESTIMATES SUPPLIED BY THE STATE SPENDING UNIT. IT IS UNDERSTOOD AND AGREED THAT THE CONTRACT SHALL COVER THE QUANTITIES ACTUALLY ORDERED FOR DELIVERY DURING THE TERM OF THE CONTRACT, WHETHER MORE OR LESS THAN THE QUANTITIES SHOWN.</p> <p>ORDERING PROCEDURE: SPENDING UNIT(S) SHALL ISSUE A WRITTEN STATE CONTRACT ORDER (FORM NUMBER WV-39) TO THE VENDOR FOR COMMODITIES COVERED BY THIS CONTRACT. THE ORIGINAL COPY OF THE WV-39 SHALL BE MAILED TO THE VENDOR AS AUTHORIZATION FOR SHIPMENT, A SECOND COPY MAILED TO THE PURCHASING DIVISION, AND A THIRD COPY RETAINED BY THE SPENDING UNIT.</p> <p>WV-39 IS NOT REQUIRED IF AGENCY IS USING P-CARD.</p> <p>BANKRUPTCY: IN THE EVENT THE VENDOR/CONTRACTOR FILES FOR BANKRUPTCY PROTECTION, THIS CONTRACT IS AUTOMATICALLY NULL AND VOID, AND IS TERMINATED WITHOUT FURTHER ORDER.</p> <p>THE TERMS AND CONDITIONS CONTAINED IN THIS CONTRACT SHALL SUPERSEDE ANY AND ALL SUBSEQUENT TERMS AND CONDITIONS WHICH MAY APPEAR ON ANY ATTACHED PRINTED DOCUMENTS SUCH AS PRICE LISTS, ORDER FORMS, SALES AGREEMENTS OR MAINTENANCE AGREEMENTS, INCLUDING ANY ELECTRONIC MEDIUM SUCH AS CD-ROM.</p> <p>PURCHASING CARD ACCEPTANCE: THE STATE OF WEST VIRGINIA CURRENTLY UTILIZES A VISA PURCHASING CARD PROGRAM WHICH IS ISSUED THROUGH A LOCAL BANK. THE SUCCESSFUL VENDOR</p>						

SEE REVERSE SIDE FOR TERMS AND CONDITIONS

SIGNATURE	TELEPHONE	DATE
see page 1 <i>Robert L. Burnett</i>		
TITLE	FEIN	ADDRESS CHANGES TO BE NOTED ABOVE

WHEN RESPONDING TO RFQ, INSERT NAME AND ADDRESS IN SPACE ABOVE LABELED 'VENDOR'



State of West Virginia
 Department of Administration
 Purchasing Division
 2019 Washington Street East
 Post Office Box 50130
 Charleston, WV 25305-0130

Request for Quotation

RFQ NUMBER
SYSFURN07

PAGE
5

ADDRESS CORRESPONDENCE TO ATTENTION OF:
BETTY FRANCISCO
304-558-0468

VENDOR

*709055848 304-340-4288
 ACCESS SYSTEMS
 4108 MACCORKLE AVENUE SE
 CHARLESTON WV 25304

SHIP TO

ALL STATE AGENCIES
 AND POLITICAL SUBDIVISIONS
 VARIOUS LOCALES AS INDICATED
 BY ORDER

DATE PRINTED 07/27/2006	TERMS OF SALE	SHIP VIA	F.O.B.	FREIGHT TERMS
-----------------------------------	---------------	----------	--------	---------------

BID OPENING DATE: **09/06/2006** BID OPENING TIME **01:30PM**

LINE	QUANTITY	UOP	CAT NO	ITEM NUMBER	UNIT PRICE	AMOUNT
<p>MUST ACCEPT THE STATE OF WEST VIRGINIA VISA PURCHASING CARD FOR PAYMENT OF ALL ORDERS PLACED BY ANY STATE AGENCY FOR ORDERS THAT ARE LESS THAN \$2,500 AS A CONDITION OF AWARD.</p> <p style="text-align: center;">NOTICE</p> <p>AN ORIGINAL, SIGNED BID MUST BE SUBMITTED TO:</p> <p style="text-align: center;">DEPARTMENT OF ADMINISTRATION PURCHASING DIVISION BUILDING 15 2019 WASHINGTON STREET, EAST CHARLESTON, WV 25305-0130</p> <p>BOTH BIDS MUST CONTAIN THIS INFORMATION ON THE FACE OF THE ENVELOPES OR THE BIDS MAY NOT BE CONSIDERED:</p> <p>SEALED BID</p> <p>BUYER:-----BETTY L. FRANCISCO - FILE 42-----</p> <p>RFQ. NO.:-----SYSFURN07-----</p> <p>BID OPENING DATE:---SEPTEMBER 6, 2006-----</p> <p>BID OPENING TIME:---1:30 P.M.-----</p> <p>PLEASE PROVIDE A FAX NUMBER IN CASE IT IS NECESSARY TO CONTACT YOU REGARDING YOUR BID:</p> <p style="text-align: center;">-----340-4293-----</p> <p>CONTACT PERSON (PLEASE PRINT CLEARLY): Jack Chandler</p>						

SEE REVERSE SIDE FOR TERMS AND CONDITIONS

SIGNATURE <i>Robert L. Burrows</i>	TELEPHONE 340-4288	DATE 9/20/06
TITLE President	FEIN 55-068-4486	ADDRESS CHANGES TO BE NOTED ABOVE

WHEN RESPONDING TO RFQ, INSERT NAME AND ADDRESS IN SPACE ABOVE LABELED 'VENDOR'



State of West Virginia
 Department of Administration
 Purchasing Division
 2019 Washington Street East
 Post Office Box 50130
 Charleston, WV 25305-0130

Request for Quotation

RFQ NUMBER
SYSFURN07

PAGE
6

ADDRESS CORRESPONDENCE TO ATTENTION OF:
BETTY FRANCISCO
304-558-0468

***709055848 304-340-4288**
ACCESS SYSTEMS
4108 MACCORKLE AVENUE SE
CHARLESTON WV 25304

ALL STATE AGENCIES
AND POLITICAL SUBDIVISIONS
VARIOUS LOCALES AS INDICATED
BY ORDER

DATE PRINTED 07/27/2006	TERMS OF SALE	SHIP VIA	F.O.B.	FREIGHT TERMS
-----------------------------------	---------------	----------	--------	---------------

BID OPENING DATE: **09/06/2006** BID OPENING TIME **01:30PM**

LINE	QUANTITY	UOP	CAT NO.	ITEM NUMBER	UNIT PRICE	AMOUNT

***** THIS IS THE END OF RFQ SYSFURN07 ***** TOTAL: _____						

SEE REVERSE SIDE FOR TERMS AND CONDITIONS

SIGNATURE *Robert L. Burrows* TELEPHONE **340-4288** DATE **9/20/06**
 TITLE **President** FEIN **55-068-4486** ADDRESS CHANGES TO BE NOTED ABOVE

WHEN RESPONDING TO RFQ, INSERT NAME AND ADDRESS IN SPACE ABOVE LABELED 'VENDOR'

SYSFURN07 – Statewide Contract Specifications for Office Furniture

SCOPE

This is a pre-qualification request for quotation. In order to meet the needs of West Virginia State Agencies, each bidder meeting the qualifications and specifications shall be awarded a contract.

The purpose is to establish contracts for the purchase of systems furniture, filing cabinets, desks, chairs, tables, and other furniture needs of the office environment. Goal will be to establish one contract for each manufacturer and to allow each agency furniture styles that meet their needs. If the contract vendor is a distributor, and their contract with the manufacturer has territory restrictions, more than one contract may be required to allow coverage of the entire State. If the contract is written to a manufacturer, distributor territory responsibility will be the sole responsibility of the manufacturer.

The successful vendor(s) shall be the contract holder. All orders shall be issued to that entity; all invoices shall be required from that contract holder; all payment shall be made to that same contract holder. **Dealers who are not contract holders shall not request West Virginia State Agencies to issue a purchase order to other than the contract holder!**

If the manufacturer is the contract holder, any relationship between that party and a servicing dealer shall be strictly between those parties. SYSFURN contracts with manufacturers shall not list dealers.

PRE-BID Meeting

A mandatory pre-bid meeting is scheduled for August 16, 2006 at 11:00 a.m. in the Purchasing Division Conference Room located at Building 15, 2019 Washington Street, East, Charleston, WV 25305. **Only vendors represented at this meeting shall be able to submit bids. Failure to attend the pre-bid conference shall disqualify a bidder from bidding on this contract.** No person can represent more than one bidder.

QUESTIONS

Questions will be accepted until August 14, 2006. Questions are to be e-mailed to: bfrancisco@wvadmin.gov; or faxed to (304) 558-4115

E-mail is the preferred method of receiving questions.

Note: Questions will be accepted and discussed at the pre-bid meeting; and upon resolution, applicable changes, if any, will be made to these specifications.

BID PREPARATION

No obligation exists for any costs incurred in preparation of the response for this request for quotation.

SYSFURN07 – Statewide Contract Specifications for Office Furniture

Two sets of price books, or price lists, or CD's should be attached to your quotation.

VENDOR ELIGIBILITY

This contract shall be limited to lines of furniture that include systems furniture, desks, file cabinets, bookcases and chairs. Manufacturers of lines that only include or cover part of these components (such as desks and/or chairs) are not eligible to bid on this contract unless such a firm has a contract with either a systems manufacturer or with a dealer (who attended the mandatory pre-bid). If a company has a subsidiary such as Kimball/National, the same bidder MAY bid both lines. Contracts shall not be awarded separately to a manufacturer without a system furniture line that meets the SYSFURN07 specifications. "Partnership" or "Alliance" companies with system furniture dealers or manufacturers may be included, either through a systems manufacturer or dealer who attended the mandatory pre-bid meeting.

In addition to compliance with this specification, all bidders shall offer a range of panel and work surface sizes and accessories consistent with general industry standards. Offerings shall include, but are not limited to: Transaction work surfaces, keyboard surfaces, various configurations of tables, flipper door cabinets, shelves with dividers, suspended drawer storage, stand alone drawer storage, mobile drawer storage, desks, task lighting, marker boards, tack boards, coat hooks, wire management, drawer accessories, paper management, electronic support accessories, tables, seating and a minimum of four (4) categories of fabric. If panel system does not meet specifications, you are not eligible under this contract. Bidders shall not offer fabrics that do not meet Class A Flammability Requirements.

Prior to any contract award, vendors shall furnish Workers Compensation certificates and proof of insurance.

I. CLASSIFICATION

TYPE I - Acoustical Panels

Style A - Communications panel with raceway for running wires and cables to adjacent panels

Style B - Electrified panels with raceway and electrical outlets

TYPE II - Non-Acoustical Panels

Style A - Communications panel with raceway for running wires and cables to adjacent panels

Style B - Electrified panels with raceway and electrical outlets

II. APPLICABLE STANDARDS

SYSFURN07 – Statewide Contract Specifications for Office Furniture

The following documents of latest issue in effect on the date of the Request for Quotations shall form part of this specification to the extent described in REQUIREMENTS:

ASTM-C423 - Sound Absorption and Sound Absorption Coefficients by the Reverberation Room Method
ASTM-E84 - Test for Surface Burning Characteristics of Building Materials
American Society For Testing and Materials (ASTM)
1916 Race Street
Philadelphia, PA 19103

NEMA-LD3-1985 - HIGH PRESSURE DECORATIVE LAMINATES
National Electrical Manufacturer's Association (NEMA)
2101 L. Street N.W.
Washington, DC 20037

ANSI/BIFMA X5.6-1986 American National Standard for Office Furnishings Panel Systems Test
American National Standards Institution
1430 Broadway
New York, NY 10018

III. REQUIREMENTS

A. GENERAL REQUIREMENTS FOR ALL TYPES OF PANELS

Note: In all references to drawings provided, it is the intent for the vendor to supply drawings to the agency.

1. Design

The open plan office system furnished under this specification shall be of the manufacturer's current standard production. The manufacturer shall offer the office open plan office system(s) to commercial and/or industrial users for a minimum period of two years. Upon request by the State, the manufacturer shall furnish references (users of the system(s) offered), to include names, telephone numbers, and addresses. The State will survey users of the proposed system to determine the long-term performance and reliability characteristics of the system. The State reserves the right to reject the system on the analysis of this information. It is the responsibility of the bidder to prove to the satisfaction of the State that the proposed system does in fact meet long-term performance and reliability standard.

- b) Panels shall be of the manufacturer's standard design. They shall be Style A, Communications or B, Electrified as specified.
- c) The raceway cover shall be securely held in place.

SYSFURN07 – Statewide Contract Specifications for Office Furniture

Notes: The same raceway may be used for both communication wires and electrical wires. If electrical system is in addition to the panel, (electrical is ordered separate and added to the panel in the field), vendor should so state and indicate the price for having the addition made.

2. Flammability

All panel constructions are to meet Class 1 or A flammability rating, in accordance to ASTM E-84 test method. See Section VI, Acceptance Evaluation and Quality Assurance.

3. Installation

Panel attachments must be designed so that users may easily be able to add and rearrange panel configurations without specialized help and/or tools and maintain original system strength and rigidity.

Connection shall provide for assembling panels in 2-way, 3-way or 4-way intersections. All panels must be individually removable without dismantling or moving adjacent panels.

Panels shall be mounted a maximum 1" off the floor for maximum noise isolation. If building conditions do not allow installation with only this distance from the floor, the vendor must get a variance from this requirement before proceeding with the installation.

When assembled, panels shall be free-standing and self-supporting; no connections to the walls, ceiling or floor shall be made without agreement with agency representative.

The dimensions and layout shall be as indicated on drawing included with the specifications. Drawings must be furnished by the vendor so the agency has a clear understanding of their purchase; panel sizes shall be as listed in the specifications. The vendor shall be responsible for verification of component quantities and sizes as set forth.

4. Construction

a) Frame

The frame shall be constructed in such a manner that it will support hang-on components, work surfaces, etc. with attendant loads, without warping, bending, flexing or breaking.

b) Fabric Covering

SYSFURN07 – Statewide Contract Specifications for Office Furniture

The fabric shall be applied smoothly and wrinkle free and the weave shall be straight with the panel. It shall be attached to the frame by a removable spline or other satisfactory method that will allow removal and replacement of fabric as required. No seams or fabric joints shall be visible in faces of panels unless required for special designs. Bidders shall not offer fabrics that do not meet Class A Flammability Requirements.

c) Vertical Support Standards

The standard shall be capable of supporting a worktop with two hanging pedestals loaded in accordance with "work surfaces with supported drawers" test ANSI/BIFMA X.5.6 1993) and meeting the acceptance level specified. Work surfaces shall be adjustable in height within a minimum range of 25"-40" in increments no greater than 1-1/4".

d) Wire Management

Panels shall be supplied in style A, communications, or B, electrified as described below.

Style A communications panels shall be communications panel with raceway to accommodate electric and/or communications cables to allow passage to adjacent panels.

Style B panels shall be electrified panels with raceways and a minimum of two pre-wired electric outlets on each side.

The raceway shall be able to accommodate all power requirements specified and 8 – 10 minimum Cat 5 or Cat 6 cables.

Style A and B panels shall also serve as in-feed panels equipped with a means of concealing cables entering from the ceiling, walls or floor.

All Style B electrified panels shall have an eight-wire, four circuit supply. All electrical components shall meet current UL and local code requirements. If the electrical system is an 8 wire UL approved, it is acceptable.

e) Panel Connections

All panel connections and perimeter framing components are to be fastened by interlocking concealed connectors and shall have smooth, tight fitting connections. No special tools shall be required for assembly or dismantling.

All connections between adjacent panels in straight runs and at intersections shall be light proof.

f) Components.

SYSFURN07 – Statewide Contract Specifications for Office Furniture

All components of panels, e.g. clips, splines, connectors, feet, posts, levelers, etc., shall be of manufacturer's standard inventory and shall be available for purchase by the user for the life of the system.

NOTE: If panels do not come from factory with electrical installed, dealer will install as required per specifications – for both Type I (Acoustical panels) and Type II (Non-Acoustical panels).

Note: All panels – including non-tackable – must be class "A" fire rated.

B. SPECIFIC REQUIREMENTS FOR PANELS

1. Design

Type I panels shall have fabric covering on both sides. The manufacturer's standard trim shall be furnished. Type II panels may be offered with or without fabric covering as specified.

2. Sound Absorption

The sound absorption rating for Type I panels shall be a minimum N.R.C. of .65 for the entire surface area of the panel, when tested in accordance with ASTM C423, latest edition. (See Section VI, Acceptance Evaluation and Quality Assurance.) Note: This sound absorption is mandatory for acoustical panels.

C. GENERAL REQUIREMENTS FOR FURNITURE COMPONENTS

1. Panel System

The panel system shall be as specified above to accommodate the components required and provide the necessary stability to make the system both safe and durable and to provide a comfortable and convenient workstation.

2. Worktops

Worktops shall be at a minimum 1-1/8" thick lumber core, minimum 1-1/8" thick 45 lbs/cu. density flake board core, or minimum 1-1/8" thick plywood core. All worktops shall be surfaced with decorative thermosetting high-pressure plastic laminate meeting NEMA- LD3 requirements.

The top shall be rounded, or soft vinyl durable edged, securely applied. Provision shall be made in the worktop to accommodate the routing of electrical cords and cables from tabletop devices and hang-on devices to the

SYSFURN07 – Statewide Contract Specifications for Office Furniture

electrical and communication outlets in the panels in a safe and orderly manner. This may be accomplished by holes w/grommets, cutouts in the worktop adjacent to the panel, cable management troughs, or other approved means.

3. Glides

All components resting on the floor shall have rustproof adjustable glides.

4. Construction

Methods and processes shall be in keeping with good industry practice and the system shall provide a safe, durable and convenient workstation for the purpose intended. Hanging components shall have adjustable mounting height

5 Locks

All drawer and door units shall be equipped with individual locks or central (master type if requested), locking system meeting ANSI/BIFMA X5.6 latest edition.

6. Safety

All hanging components must meet ANSI/BIFMA's Component Dislodgement Test.

7. Electrical Attachments

All electrical attachments that may be furnished with the office systems covered in this specification shall be UL approved for use with panel systems and shall bear the UL label or nameplate.

8. Size

Sizes shall be the manufacturers' standard sizes and length shall be as required to mesh with panel standards in the location indicated.

D. General Requirements for Filing Cabinets

Specifications provide three quality levels of metal casework office furniture for use by state government agencies. Quality levels are Class A Heavy Duty, Class B Medium Duty and Class C Light Duty.

Bidders are to provide pricing on selected metal office furniture that meet or exceed the minimum specifications and to provide discounted pricing on the metal standalone casework (filing and storage cabinets, desks, and

SYSFURN07 – Statewide Contract Specifications for Office Furniture

credenzas) from the same model line. All furniture of the same model line shall have the same color selections available.

The classes are:

Class A Heavy Duty, Heavy Use - Where drawers are used 25 times or more per day with a weight of two pounds per linear inch for letter size and three pounds per linear inch for legal-size drawers. Drawer suspension cycle test must pass a minimum of 100,000 cycles. All components of the suspension shall be manufactured of not less than 16 gauge steel and suspension shall be steel ball bearings.

Class B Medium, Medium Use - Where drawers are used 20 times or more per day with a weight of two pounds per linear inch for letter size and three pounds per linear inch for legal-size drawers. Drawer suspension cycle test must pass a minimum of 75,000 cycles. All components of the suspension shall be manufactured of not less than 16 gauge steel and suspension shall be steel ball bearings or nylon/celcon with steel ball bearings.

Class C Light Duty, Light Use - Where drawers are used less than 20 times per day with a weight of two pounds per linear inch for letter size and three pounds per linear inch for legal-size drawers. Drawer suspension cycle test must pass a minimum of 50,000. Vertical file cabinets have a smaller depth than those in Classes A and B.

General: All vertical file cabinets shall meet or exceed the requirements of ANSI/BIFMA X5.3 and lateral files shall meet or exceed ANSI/BIFMA X5.2 - Office Furnishing Lateral File Test.

All metal furniture shall be free from defects, imperfections, or hazards that might affect appearance, normal life, service, or user safety. All panel finishes must pass ASTM D-3359 Method B Classification 5B for adhesion and ASTM-3363 for hardness, or meet or exceed ANSI/BIFMA X5.6-2003

All welds shall be sound and without porosity. Exterior welds shall be smooth and interior welds shall have no sharp edges or rough surfaces. Welds, rivets and braces shall assure rigidity, strength and proper alignment.

File cabinets shall have one piece or utilized construction. If modular construction is used, each module shall be unitized. File cabinets shall not tilt or deviate from a true vertical state.

Vertical File Drawer Construction: The drawer shall have a positive acting spring latch capable of holding loaded drawer closed at any tilt angle; this latch shall have free movement only in the horizontal plane parallel to the drawer front. The release button shall fit snugly to the drawer front and shall be located conveniently to the drawer pull.

SYSFURN07 – Statewide Contract Specifications for Office Furniture

A label holder shall be located in center of drawer front above the drawer pull.

The follower shall have not more than 3/4" maximum increment movement, and shall be easy to adjust.

Locks shall be provided where requested.

Lateral File Drawer Construction: The cabinet front, sides, back, top and interior members (drawers and shelves) shall be manufactured of not less than 22 gauge steel, rigidly formed, braced, and welded to withstand heavy usage without distortion, warping or twisting. Drawers and roll-out shelves shall operate on full ball-bearing progressive suspensions. Members of the suspension shall be cold drawn steel, zinc plated or other suitable material to prevent rust, and of adequate strength to support loaded shelves or drawers. Suspension shall accommodate uneven drawer loading and uneven push or pull forces when opening or closing. Drawers and shelves shall operate smoothly without noticeable sticking or uneven motion. Lateral files must comply with ANSI/FIFMA X5.2, Sections 4,5,6,7,8,9,10,11,12,13 and 14.

The drawer shall have a positive acting spring latch capable of holding loaded drawer closed at any tilt angle; this latch shall have free movement only in the horizontal plane parallel to the drawer front. The release button shall fit snugly to the drawer front and shall be located conveniently to the drawer.

File Cabinet Paint Colors: For each model line available on this contract, all paint colors listed in the manufacturer's published catalog as available for that model/series are to be available at the base price offered herein, without up charges.

E. CONSTRUCTION OF INDIVIDUAL COMPONENTS

1. Worktops

For the purposes of this specification, a "worktop", or "work surface" is defined as a single unit of construction with properties as set forth in Section III.C.2 of this specification. The worktop shall be so constructed that hanging drawer units may be attached underneath the top. Worktop shall meet requirements of static load test for work surfaces of ANSIIIBIFMA X5.6 latest edition.

The worktop shall be supported at each end by one, or more, of the following means, and may be mounted by employing any one, or more, of the following methods.

- a) End clip attached to panel vertical support standard
- b) Floor-standing pedestal
- c) Cantilever bracket

SYSFURN07 – Statewide Contract Specifications for Office Furniture

- d) Floor-standing leg, with bracket(s) to attach worktop to vertical support standard. When floor-standing leg is used, the installation of such shall not restrict, or interfere with the movements of the occupant.
- e) A combination of any of the above. Ex: Floor-standing pedestal with cantilever bracket, end clip, leg, or a second floor-standing pedestal.

Worktops 72", or greater, which have an unsupported span of 66", or greater, shall have at least one intermediate support. For the purposes of this specification, "intermediate support" is defined as: a) Floor-standing pedestal, b) Cantilever bracket or c) Floor-standing leg. All worktops shall be adequately supported to prevent sagging.

2. Hanging Pedestal Drawer Units

The pedestal units shall be steel, provided with a method of secure fastening to the underside of the worktop. Drawer fronts may be durable commercial-type plastic. When attached, the entire unit, pedestals and worktop shall meet the requirements of ANSI/BIFMA Tests, Section VI. Unless otherwise specified, pedestal depth dimension shall be a minimum of 18".

3. Pedestal Drawer Units, Mobile Type or Floor Standing

The pedestal unit shall be steel, equipped with casters or shall stand on the floor as specified. It shall fit under the worktop without excessive vacant space between the pedestal and top. The units shall meet the requirements of ANSI/BIFMA Tests, Section VI. The pedestal depth dimension shall conform to the surface depth dimension.

4. Hanging Binder Cabinet

The unit shall be front opening cabinet for storing ring binders. It may be equipped with doors hinged at top or bottom with lid supports to prevent accidental dropping of the front, or it may be equipped with sliding doors. The unit may be fabric covered or in other materials. It shall meet the requirements of ANSI/BIFMA Tests, Section VI. The overall dimension front to back shall not exceed 16 1/4".

5. Hanging Shelf Unit (Full height and half height)

The unit shall be a horizontal shelf designed to accommodate vertical dividers to be supplied when specified. It shall meet the requirements of ANSI/BIFMA tests, Section VI.

6. Power Poles

Unless otherwise specified, in feed from the ceiling shall be through a rigid pole from the ceiling to the panel connection. Flexible in feed from the ceiling

SYSFURN07 – Statewide Contract Specifications for Office Furniture

to the panel connection is not acceptable. All in feeds shall be through UL approved connectors.

7. Colors

Unless otherwise specified, the manufacturer's standard color offering shall be acceptable.

8. Paper Management

All flat shelves and storage units shall have available at least the following: Vertical shelf dividers and stacked or stacking paper bins for horizontal paper storage. All shelves, metal end supports and full height panels, for heavy-duty use must have safety locks to prevent accidental dislodgement.

9. Miscellaneous Accessories

The system shall have available accessory items for filing; coat hooks, racks, doors, etc., and will be required when specified.

F. WORKMANSHIP AND INSTALLATION

Qualification of bidders: Each bidder should include information as to the qualifications of the company, designers and installers who will perform the work. This information shall be considered and must be received prior to any award.

Contractor shall provide all labor and material necessary for a complete installation as shown on the floor plan attached to the specifications. This will include such work as leveling, installing accessories, alignment, wiring (if required), etc. Data and phone wiring will be the responsibility of the agency.

The finished installation of panel configurations shall not sway and must be clean and free from any defects, which may affect the appearance or serviceability.

Only manufacturer's standard products in design, materials, and construction, not modified versions produced for conformance to our specifications will be considered for evaluation and acceptance. Any questions concerning acceptability of the quality offered shall be the decision of the Division of Purchasing.

The entire system installation shall be in accordance with the manufacturer's guidelines for a safe and stable system. However, any deviation from the standard specification to achieve a safe and stable system must be submitted for review and approval by this office.

SYSFURN07 – Statewide Contract Specifications for Office Furniture

The contractor shall be a qualified representative of the acoustical panel system manufacturer, who has specially trained installers that are thoroughly familiar with all aspects of the system.

G. Task Chairs

A demo for all task chairs purchased through this contract must be made available for employee/ workstation tryout for a minimum of three working days. Chairs purchased without this "tryout period" are subject to return without charge.

All task chairs must have the following adjustable features:

1. Seat pan height
2. Back depth/seat depth – either through a seat slider or back depth adjuster or equivalent
3. Back or lumbar support height adjustment
4. Arm height

All task chairs that are sold as "ergonomic" chairs MUST have the following adjustable features:

1. Seat pan height
2. Seat pan angle
3. Back Depth/seat depth – either through a seat slider or back depth adjuster or equivalent
4. Back or lumbar support height adjustment
5. Back angle
6. Arm height
7. Arm width – both inward and outward from center line of the arm.

NOTE: Items 6 and 7 on the ergonomic chairs may be waived **IF** the purchaser does not wish to have arms on the chair being purchased.

IV. WARRANTY

The vendor warrants to the owner that all equipment furnished under this specification will be new, of good material and workmanship, and agrees to replace promptly any part or parts which by reason of defective material or workmanship shall fail under normal use, free of negligence accident, for the periods from date of acceptance, as outlined below:

- A. Structural Frames: Life of system (for as long as the user owns the system)
- B. Fabric: One Year
- C. All Other Components: Ten years

SYSFURN07 – Statewide Contract Specifications for Office Furniture

Such replacement shall be free of any charge to the owner or his representative. For the purpose of this warranty, normal use shall be defined as the use in state office building with climatic conditioning equipment operated as directed by State policy, e.g. air conditioning or heat turned off during weekends creating wide temperature and humidity variations.

Failure shall include, but not be limited to, warped, broken, or separated frames, separation of vertical support standards from frame, disfigurement or enlargement of slots in vertical support standards, warping or separation of joints in wood products, sagging or warping of work surface failure or separation of laminate from work surfaces and trim, separation of edging material from work surface edges, and any other failure which would make the system unsatisfactory for its intended use.

V. SERVICE, PARTS, AND MANUALS

At least one owner's manual shall be supplied with each installation. The complete assembly and disassembly instructions for panels, including all necessary parts lists and diagrams for future installation must be included. The manufacturer of the furniture panel system offered under this specification shall have a qualified, trained representative in the owner's area available to relocate and repair the panel systems acquired under this specification. The vendor shall provide training to representatives of the owner encompassing installation, takedown, repair and maintenance of panel systems as required. If this is requested, the vendor should provide, but must inform the agency representative that the warranty may be voided if a qualified representative does not work on the panel system.

VI. ACCEPTANCE EVALUATION AND QUALITY ASSURANCE

An acceptance inspection of the installation will be performed when specified by the agency or his representative.

Under this specification, all prospective bidders of furniture shall provide manufacturer's certification of in-house testing results or independent testing results for ANSI/BIFMA, ASTM E-84, and ASTM C423 testing. Manufacturer's certification shall be in the form of a corporate officer providing certification on corporate letterhead that the model line (by name) meets all required testing and the test results are available upon request.

All test results shall meet or exceed the applicable test requirements. Tests must be performed on the actual system offered for bid. If the manufacturer should change or modify the construction of open plan office system, the manufacturer shall notify the Purchasing Division of any change in the commodities failure to comply with the required testing and/or provide new certified testing results. The vendor shall be responsible for performance of all test requirements specified herein.

The following publication, latest issue, contains the applicable ANSI/BIFMA Tests:

SYSFURN07 – Statewide Contract Specifications for Office Furniture

ANSIIBIFMA X5.6-1993 American National Standard Tests for Office Furnishings-Panel Systems Tests.

The following tests are required:

Section 4 - Stability Test for Panel System Products
Section 5 - Mechanical Strength Test For Panel Systems Products
Section 6 - Static Load Test for Storage Shelves
Section 8 - Cabinet Tests: 8.2, 8.3, 8.4, and 8.5
Section 11 - Static Load Test for Work Surfaces
Section 12 - Work Surfaces With Supported Drawers Test: 12.2,12.3,12.4,12.5, 12.6
Section 13 - Dislodgement Test for Panel-Mounted Components
ASTM-C423, Sound Absorption and Sound Absorption Coefficients by the Reverberation Room Method. ASTM-E84, Test For Surface Burning Characteristics of Building Materials

Acoustical tests for noise reduction coefficient ratings shall be by ASTM-C423 Sound Absorption and Sound Absorption Coefficients by the Reverberation Room Method. A minimum N.R.C .65 for the entire surface area of the panel, including raceway(s), trim (top cap), and legs, is required.

Flammability testing shall be in accordance with ASTM-E84, test for surface burning characteristics of building materials. When tested in this manner, the panel shall have a flame spread of 25 or less and smoke development of 450 or less for Class 1 or A flammability.

VII. DELIVERY

Delivery of all equipment under this specification shall be in accordance with the terms and conditions of the Request for Quotation. The vendor shall be responsible for any packing, packaging, or protection required to insure delivery in an undamaged condition. Vendor shall be responsible for installation.

Bidders may offer a separate (higher) discount for dockside delivery. But, this must be in addition to the discount shown for complete installation. **All bids must show the cost (discount from list) for total installation. Bidders shall be disqualified if only dockside delivery is quoted.**

VIII. ORDERING DATA (For Purchase and Contract Use Only)

Purchasers should exercise any desired options offered herein and should specify the following:

Title, number, and date

Panel Type (Type I - Acoustical, Type II Non-Acoustical)

Layout of the system showing communication and electrical in feed requirements for panels.

Electrical requirements (2-Circuit, 4-Circuit, dedicated circuit, etc.)

SYSFURN07 – Statewide Contract Specifications for Office Furniture

Panel sizes and styles, appropriate drawings must be provided
Hang on components.

Type II panels - specify if fabric covered or not.

Specify fabric type and color - bidders shall not offer fabrics that do not meet Class A
Flammability Requirements.

If pedestal drawer units are required, specify hanging, mobile, or floor standing.
Pedestal depth dimensions to conform to work surface depth dimension.

Power pole requirements.

Color

Miscellaneous accessories that are required

Appliances requirements, such as task lights

Sample mock-up requirements.

Top cap material for panels

Task Chair requirements-purchasers must allow time for the affected employees to try
the chairs. If bidding (through SYSFURN07 vendors), the users shall try chairs before
obtaining bids in order to make certain bids are "equal" on task chairs. Task chair
purchasers must indicate if they require an "ergonomic" chair", but the demo is required
for any task chair.

Bidder and user responsibilities for installation of the system.

Notes:

Add-On to Existing Configurations

Agencies are permitted to contact the brand specific contract holder for systems
that require additional items being added to existing systems for matching and
functionality purposes.

New Configurations

Any new installation in un-occupied space (or where matching is not a factor)
requires three (3) bids from contract holders. An award shall be issued to low
bidder meeting the agency specifications for that bid.

IX. Miscellaneous Information

Delivery Time: Vendor shall provide the current delivery time from receipt of order.
Upon receipt of a contract order, the vendor is to notify (within 5 work days) the
purchaser of the delivery time frame. Vendor shall coordinate the delivery and
installation times with the purchaser.

Transportation Charges: All items shall be delivered FOB to any West Virginia
destination with all transportation charges included.

Inside Delivery: The vendor is to provide all labor and equipment to deliver, un-crate,
assemble (if required), set in place ready for agency to use in desired location as
determined by the purchaser, and remove all packing materials from the job site. The
vendor is to coordinate the installation with the state agency's contact person for the
installation.

SYSFURN07 – Statewide Contract Specifications for Office Furniture

Design/Reconfiguration Charge: (If any; some firms do not charge a fee for design – either original or reconfiguration.) If the agency makes a written request for the vendor's design assistance, the vendor may charge an hourly fee for the on-site services. Vendor's design fee is limited to \$30.00 per hour with a \$500 maximum per project. The design fee is to be reviewed and accepted by the using agency. In a Request for Quotation, (outside any contracts issued) the agency is not obligated to a bidder for any costs incurred in the submission of a bid. **List your fee on Exhibit A.**

Move Fee: This hourly fee for moving systems shall be a maximum of \$30.00. Moves required after 5:00 p.m. and/or on weekends shall be a maximum of \$45.00/hour. If your hourly rate is less than \$30.00, the overtime rate shall be one and one-half times the hourly rate shown on your bid documents.

Note: This No installation fee shall be charged at the initial installation. Purchase price includes all installation fees. **List your fee on Exhibit A.**

Price list and catalogs: The vendor shall agree to supply and deliver descriptive literature to the agencies at no charge. The descriptive literature shall include furniture catalogs and price lists for the model lines awarded on this contract. Discount from list will be firm for life of the contract; including any renewals. New manufacturer's catalogs will be considered at renewal anniversary dates. Vendor shall respond to calls and inquiries within three business days of the initial contact by the agency.

Invoicing: The vendor's invoice shall include an itemized listing of the components supplied and installed at the agency location. Vendor's invoice must list the quantity, description and model number, page number on which the model number and price can be found, unit price, and the total price. This is a mandatory requirement and is necessary for the Agency and State Auditor to confirm the pricing of each component.

Vendor's Performance: All users of this contract are requested to report in writing to the Purchasing Division any serious problems encountered with the performance, quality, and workmanship of items or performance of the successful vendor to supply and properly warrant the equipment furnished hereunder.

Reports: Vendors who are awarded contracts shall provide quarterly reports of orders as a result of this contract by both state and political sub-divisions within the State of West Virginia. Reports shall indicate the ordering agency, date and total value. Additionally, an annual composite report listing total value and total number of orders for all state agencies and political subdivisions shall be required.

NOTE: All successful vendors shall be required to meet this requirement on SYSFURN07.

Correctional Industries: The State of West Virginia Department of Corrections is authorized to furnish and supply office furniture to the state agencies. It is not the intent of this contract to supercede the rights of the Department of Corrections. All state

SYSFURN07 – Statewide Contract Specifications for Office Furniture

agencies are to contact the WV Department of Corrections, Prison Industries to determine if the same or similar item is available from the Department of Corrections prior to purchasing items through the statewide contract.

Ordering Procedure: Note: A detailed design and a price quote must be submitted to and approved by the agency prior to issuing any order. If the design is for new quarters (not an expansion of existing system cubicles), agencies must prepare specifications and seek a minimum of three bids. The award shall be to low bidder meeting specifications. Bids must also be obtained if the system cubicles will be installed on a different floor

Purchases of \$100,000 or less: State Agencies shall issue a WV39, Blanket Release Order to the contract Vendor for the desired item(s) after meeting bidding requirements of for new area.

Purchases in excess of \$100,000: Purchases in excess of \$100,000 will be reviewed by the Purchasing Division. At the discretion of the Director of Purchasing, or his designee, these requirements may be bid on the open market.

Payment: The State of West Virginia agencies may make purchases on the State Payment Card (VISA) for purchases with a maximum value of \$2,500.00. Vendor's invoice must list the quantity, description or model number, page number on which the model number and price can be found, unit price, and the total price.

Evaluation of Bids:

To facilitate meeting the furniture needs of the West Virginia State Agencies this shall be a multiple award contract for furniture; one contract per manufacturer, insofar as possible.

It is the bidder's responsibility to document that all furniture offered is equal to or exceeds the specifications.

Bidder may bid one or more manufacturer's catalog/price list, model line and number, showing discount from list for each. Each bid must contain a "full service line", system panels, cabinets, chairs, etc.

The attached Exhibit A must be completed showing discount/multiplier being offered for each brand and line of furniture to be bid. Please type, using excel document to be provided after the mandatory pre-bid meeting.

Notes:

- 1. All awards will be made based on discount from list. No exceptions to discount from list.**
- 2. All catalogs/lines bid must be on this list.**
- 3. Bidders should submit Exhibit A on a diskette or CD with their bid.**

SYSFURN07 – Statewide Contract Specifications for Office Furniture

4. If you are bidding the entire catalog, simply identify the catalog. Each line in such catalog does not require listing UNLESS the discounts from list vary from line to line.

Bidders are requested to type the exhibits. If any discrepancy exists between the paper and the electronic file, the hard paper copy shall prevail.

RFQ Schedule

Release of the RFQ	July 27, 2006
Pre-Bid Conference	August 16, 2006 – 11:00 a.m.
*Vendor's Written Questions Submission Deadline	August 14, 2006
Response to Questions/Addendum Issued	August 22, 2006
Bid Opening Date	September 6, 2006

EXHIBIT A
SYSFURN07

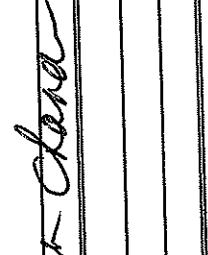
Vendor/Contact Information	Manufacturer	Model/Line/ Product	Catalog Identifier	Discount %
Vendor: <u>Access Systems</u>				
Contract Coordinator: <u>Jack Chandler</u>				
Address: <u>4108 MacCorkle Ave. SE</u> <u>Charleston WV 25304</u>				
Phone#: <u>340-4288</u>				
Fax#: <u>340-4293</u>				
Toll Free# :				
Email: <u>ichandler@accesswv.com</u>				
Labor Rate:				
Design Fee:				
				
Signature				

Certification

ABATMNT07

By submitting a signed bid for SYSFURN07 – supplying system furniture and other furniture requirements – vendor hereby certifies under penalty of fraud that all mandatory specifications contained in the Request for Quotation are met.

Access Systems

Vendor (Type Name of Company)

4108 MacCorkle Ave SE Charleston WV 25304

Address

Robert L. Burnworth
Name (Type Name)

President
Title

Signature

9/20/06
Date

Note: No contract shall be awarded prior to receipt of this certification.

AFFIDAVIT

West Virginia Code §5A-3-10a states:

No contract or renewal of any contract may be awarded by the state or any of its political subdivisions to any vendor or prospective vendor when the vendor or prospective vendor or a related party to the vendor or prospective vendor is a debtor and the debt owned is an amount greater than one thousand dollars in the aggregate.

DEFINITIONS:

"Debt" means any assessment, premium, penalty, fine, tax or other amount of money owed to the state or any of its political subdivisions because of a judgment, fine, permit violation, license assessment, defaulted workers' compensation premium, penalty or other assessment presently delinquent or due and required to be paid to the state or any of its political subdivisions, including any interest or additional penalties accrued thereon.

"Debtor" means any individual, corporation, partnership, association, limited liability company or any other form or business association owing a debt to the state or any of its political subdivisions.

"Political subdivision" means any county commission; municipality; county board of education; any instrumentality established by a county or municipality; any separate corporation or instrumentality established by one or more counties or municipalities, as permitted by law; or any public body charged by law with the performance of a government function or whose jurisdiction is coextensive with one or more counties or municipalities.

"Related party" means a party, whether an individual, corporation, partnership, association, limited liability company or any other form or business association or other entity whatsoever, related to any vendor by blood, marriage, ownership or contract through which the party has a relationship of ownership or other interest with the vendor so that the party will actually or by effect receive or control a portion of the benefit, profit or other consideration from performance of a vendor contract with the party receiving an amount that meets or exceeds five percent of the total contract amount.

EXCEPTION:

The prohibition of this section does not apply where a vendor has contested any tax administered pursuant to chapter eleven of this code, workers' compensation premium, permit fee or environmental fee or assessment and the matter has not become final or where the vendor has entered into a payment plan or agreement and the vendor is not in default of any of the provisions of such plan or agreement.

LICENSING:

The vendor must be licensed in accordance with any and all state requirements to do business with the state of West Virginia.

CONFIDENTIALITY:

The vendor agrees that he or she will not disclose to anyone, directly or indirectly, any such personally identifiable information or other confidential information gained from the agency, unless the individual who is the subject of the information consents to the disclosure in writing or the disclosure is made pursuant to the agency's policies, procedures and rules. Vendors should visit www.state.wv.us/admin/purchase/privacy for the Notice of Agency Confidentiality Policies.

Under penalty of law for false swearing (West Virginia Code, §61-5-3), it is hereby certified that the vendor acknowledges the information in this said affidavit and are in compliance with the requirements as stated.

Vendor's Name: Access Systems

Authorized Signature: Robert L Burnworth Date: 9/20/06

Robert L. Burnworth



State of West Virginia
 Department of Administration
 Purchasing Division
 2019 Washington Street East
 Post Office Box 50130
 Charleston, WV 25305-0130

Request for Quotation

RFQ NUMBER: SYSFURN07

PAGE: 1

ADDRESS CORRESPONDENCE TO ATTENTION OF: BETTY FRANCISCO 304-558-0468
--

VENDOR

Access Systems
Tammra Neville
4108 MacCorkle Ave.
Charleston, WV 25304

SHIP TO

**ALL STATE AGENCIES
 AND POLITICAL SUBDIVISIONS
 VARIOUS LOCALES AS INDICATED
 BY ORDER**

DATE PRINTED 08/27/2006	TERMS OF SALE	SHIP VIA	F.O.B.	FREIGHT TERMS
-----------------------------------	---------------	----------	--------	---------------

BID OPENING DATE: **09/20/2006** BID OPENING TIME **01:30PM**

LINE	QUANTITY	UOP	CAT NO	ITEM NUMBER	UNIT PRICE	AMOUNT
ADDENDUM # 01						
<p>1. IF MANUFACTURER SIMPLY CHANGES THE CODES OR THE NUMBERING SYSTEM IDENTIFYING PRODUCTS, THOSE CHANGES WILL BE ACCEPTED WHEN THEY OCCUR. NOTE: IF ANY PRICING CHANGES OCCUR WITH THIS CHANGE, THEY WILL ONLY BE ACCEPTED AT RENEWAL. ANY CHANGE OF MODEL NUMBERS ACCEPTED MUST INCLUDE ENTIRE REPLACEMENT OF THE PRICING BOOK/CD/ETC. NO PARTIAL LIST OF ITEMS IN CATALOG, ETC. SHALL BE ACCEPTED.</p> <p>2. SPECIFICATIONS, REVISED 8/24, ARE ATTACHED.</p> <p>3. THE MAXIMUM RATE OF \$30.00/HOUR APPLIES TO BOTH DESIGN AND LABOR FOR REARRANGEMENT. NO LABOR FEE WILL BE PERMITTED WITH NEW INSTALLATION.</p> <p>4. SECTION D - GENERAL REQUIREMENTS FOR FILING CABINETS: PREVIOUSLY REQUESTED "PRICING". THAT HAS BEEN DELETED FROM THE REVISED SPECIFICATIONS. NOTE: BIDDERS SHOULD LIST THE CLASS OF ALL FILE CABINETS BID, A, B, OR C.</p> <p>5. PROOF OF INSURANCE AND WORKER'S COMPENSATION SHALL BE REQUIRED PRIOR TO ANY AWARD.</p> <p>6. IT WAS REQUESTED THAT THE USERS BE REQUIRED TO PERFORM ROUTINE MAINTENANCE. THIS REQUEST IS DENIED. THE POTENTIAL FOR THE USER TO DAMAGE THE SYSTEM FURNITURE AND THEREBY VOID THE WARRANTY IS TOO GREAT. CONTRACT HOLDER WHO IS AWARDED AND SUPPLIES THE SYSEM FURNITURE IS RESPONSIBLE FOR ALL MAINTENANCE.</p>						

SEE REVERSE SIDE FOR TERMS AND CONDITIONS

SIGNATURE <i>Robert L. Burman</i>	TELEPHONE 340-4288	DATE 9/20/06
TITLE President	FEIN 55-068-4486	ADDRESS CHANGES TO BE NOTED ABOVE

WHEN RESPONDING TO RFQ, INSERT NAME AND ADDRESS IN SPACE ABOVE LABELED 'VENDOR'



State of West Virginia
 Department of Administration
 Purchasing Division
 2019 Washington Street East
 Post Office Box 50130
 Charleston, WV 25305-0130

Request for Quotation

RFQ NUMBER
SYSFURN07

PAGE
2

ADDRESS CORRESPONDENCE TO ATTENTION OF:
BETTY FRANCISCO
304-558-0468

RFQ COPY
 TYPE NAME/ADDRESS HERE

VENDOR

SHIP TO

ALL STATE AGENCIES
 AND POLITICAL SUBDIVISIONS
 VARIOUS LOCALES AS INDICATED
 BY ORDER

DATE PRINTED	TERMS OF SALE	SHIP VIA	F.O.B.	FREIGHT TERMS
08/27/2006				

BID OPENING DATE: **09/20/2006** BID OPENING TIME **01:30PM**

LINE	QUANTITY	UOP	CAT NO	ITEM NUMBER	UNIT PRICE	AMOUNT
<p>7. REQUEST RECEIVED TO REPLACE THE WARRANTY REQUIREMENTS WITH THE COMPANY LIMITED WARRANTIES. REQUEST DENIED. CONTRACTS WILL BE AWARDED TO COMPANIES WHO MEET THE SPECIFICATIONS CONTAINED IN THE RFQ.</p> <p>8. IF A VENDOR REPRESENTED AT THE PRE-BID HAS MORE THAN ONE LINE, THAT BIDDER MAY BID MORE THAN ONE LINE - BIDDER MUST BID SYSTEM LINE TO QUALIFY FOR ANY AWARD.</p> <p>9. ALL STATE AGENCIES WILL NOT BE REQUIRED TO BID NEW SYSTEMS IF THE ANTICIPATED COST IS IN EXCESS OF \$2,500. A QUESTION WAS RECEIVED ON WHY HAVE A CONTRACT IF THIS IS THE PROCESS. THE BIDS WILL ONLY BE SOLICITED FROM CONTRACT HOLDERS; IF YOU DO NOT BID FOR ONE OF THE CONTRACTS, YOU WILL NOT BE ABLE TO BID FOR THOSE BETWEEN THE \$2,500 AND \$100,000 THRESHOLD. OVER \$100,000, THEY ARE SENT TO THE PURCHASING DIVISION FOR A DECISION TO PUBLICLY BID OR AWARD TO THE CONTRACT HOLDER.</p> <p>10. CD'S WILL BE ACCEPTED IN LIEU OF PRODUCT BOOKS. THESE MUST BE "USER FRIENDLY" CD'S THAT CAN BE USED TO VERIFY THE PRICES AND DISCOUNTS ON ALL PURCHASES.</p> <p>11. THE BID OPENING DATE HAS BEEN CHANGED TO WEDNESDAY, SEPTEMBER 20, 2006.</p> <p>*****END OF ADDENDUM # 01*****</p>						

SEE REVERSE SIDE FOR TERMS AND CONDITIONS

SIGNATURE see page 1 <i>Robert L. Burrows</i>	TELEPHONE	DATE
TITLE FEIN	ADDRESS CHANGES TO BE NOTED ABOVE	

WHEN RESPONDING TO RFQ, INSERT NAME AND ADDRESS IN SPACE ABOVE LABELED 'VENDOR'

SYSFURN07 – Statewide Contract Specifications for Office Furniture

SCOPE

This is a pre-qualification request for quotation. In order to meet the needs of West Virginia State Agencies, each bidder meeting the qualifications and specifications shall be awarded a contract.

The purpose is to establish contracts for the purchase of systems furniture, filing cabinets, desks, chairs, tables, and other furniture needs of the office environment. Goal will be to establish one contract for each manufacturer and to allow each agency furniture styles that meet their needs. If the contract vendor is a distributor, and their contract with the manufacturer has territory restrictions, more than one contract may be required to allow coverage of the entire State. If the contract is written to a manufacturer, distributor territory responsibility will be the sole responsibility of the manufacturer.

The successful vendor(s) shall be the contract holder. All orders shall be issued to that entity; all invoices shall be required from that contract holder; all payment shall be made to that same contract holder. **Dealers who are not contract holders shall not request West Virginia State Agencies to issue a purchase order to other than the contract holder!**

If the manufacturer is the contract holder, any relationship between that party and a servicing dealer shall be strictly between those parties. SYSFURN contracts with manufacturers shall not list dealers.

PRE-BID Meeting

A mandatory pre-bid meeting is scheduled for August 16, 2006 at 11:00 a.m. in the Purchasing Division Conference Room located at Building 15, 2019 Washington Street, East, Charleston, WV 25305. **Only vendors represented at this meeting shall be able to submit bids. Failure to attend the pre-bid conference shall disqualify a bidder from bidding on this contract.** No person can represent more than one bidder.

QUESTIONS

Questions will be accepted until August 14, 2006. Questions are to be e-mailed to: bfrancisco@wvadmin.gov; or faxed to (304) 558-4115

E-mail is the preferred method of receiving questions.

Note: Questions will be accepted and discussed at the pre-bid meeting; and upon resolution, applicable changes, if any, will be made to these specifications.

SYSFURN07 – Statewide Contract Specifications for Office Furniture

BID PREPARATION

No obligation exists for any costs incurred in preparation of the response for this request for quotation.

Two sets of price books, or price lists, or CD's should be attached to your quotation.

VENDOR ELIGIBILITY

This contract shall be limited to lines of furniture that include systems furniture, desks, file cabinets, bookcases and chairs. Manufacturers of lines that only include or cover part of these components (such as desks and/or chairs) are not eligible to bid on this contract unless such a firm has a contract with either a systems manufacturer or with a dealer (who attended the mandatory pre-bid). If a company has a subsidiary such as Kimball/National, the same bidder MAY bid both lines. Contracts shall not be awarded separately to a manufacturer without a system furniture line that meets the SYSFURN07 specifications. "Partnership" or "Alliance" companies with system furniture dealers or manufacturers may be included, either through a systems manufacturer or dealer who attended the mandatory pre-bid meeting.

In addition to compliance with this specification, all bidders shall offer a range of panel and work surface sizes and accessories consistent with general industry standards. Offerings shall include, but are not limited to: Transaction work surfaces, keyboard surfaces, various configurations of tables, flipper door cabinets, shelves with dividers, suspended drawer storage, stand alone drawer storage, mobile drawer storage, desks, task lighting, marker boards, tack boards, coat hooks, wire management, drawer accessories, paper management, electronic support accessories, tables, seating and a minimum of four (4) categories of fabric. If panel system does not meet specifications, you are not eligible under this contract. Bidders shall not offer fabrics that do not meet Class A Flammability Requirements.

Prior to any contract award, vendors shall furnish Workers Compensation certificates and proof of insurance.

I. CLASSIFICATION

TYPE I - Acoustical Panels

Style A - Communications panel with raceway for running wires and cables to adjacent panels

Style B - Electrified panels with raceway and electrical outlets

TYPE II - Non-Acoustical Panels

Style A - Communications panel with raceway for running wires and cables to adjacent panels

Style B - Electrified panels with raceway and electrical outlets

SYSFURN07 – Statewide Contract Specifications for Office Furniture

II. APPLICABLE STANDARDS

The following documents of latest issue in effect on the date of the Request for Quotations shall form part of this specification to the extent described in REQUIREMENTS:

ASTM-C423 - Sound Absorption and Sound Absorption Coefficients by the Reverberation Room Method

ASTM-E84 - Test for Surface Burning Characteristics of Building Materials
American Society For Testing and Materials (ASTM)
1916 Race Street
Philadelphia, PA 19103

NEMA-LD3-1985 - HIGH PRESSURE DECORATIVE LAMINATES
National Electrical Manufacturer's Association (NEMA)
2101 L. Street N.W.
Washington, DC 20037

ANSI/BIFMA X5.6-1986 American National Standard for Office Furnishings Panel Systems Test
American National Standards Institution
1430 Broadway
New York, NY 10018

III. REQUIREMENTS

A. GENERAL REQUIREMENTS FOR ALL TYPES OF PANELS

Note: In all references to drawings provided, it is the intent for the vendor to supply drawings to the agency.

1. Design

The open plan office system furnished under this specification shall be of the manufacturer's current standard production. The manufacturer shall offer the office open plan office system(s) to commercial and/or industrial users for a minimum period of two years. Upon request by the State, the manufacturer shall furnish references (users of the system(s) offered), to include names, telephone numbers, and addresses. The State will survey users of the proposed system to determine the long-term performance and reliability characteristics of the system. The State reserves the right to reject the system on the analysis of this information. It is the responsibility of the bidder to prove to the satisfaction of the State that the proposed system does in fact meet long-term performance and reliability standard.

SYSFURN07 – Statewide Contract Specifications for Office Furniture

- b) Panels shall be of the manufacturer's standard design. They shall be Style A, Communications or B, Electrified as specified.
- c) The raceway cover shall be securely held in place.

Notes: The same raceway may be used for both communication wires and electrical wires. If electrical system is in addition to the panel, (electrical is ordered separate and added to the panel in the field), vendor should so state and indicate the price for having the addition made.

2. Flammability

All panel constructions are to meet Class 1 or A flammability rating, in accordance to ASTM E-84 test method. See Section VI, Acceptance Evaluation and Quality Assurance.

3. Installation

Panel attachments must be designed so that users may easily be able to add and rearrange panel configurations without specialized help and/or tools and maintain original system strength and rigidity.

Connection shall provide for assembling panels in 2-way, 3-way or 4-way intersections. All panels must be individually removable without dismantling or moving adjacent panels.

Panels shall be mounted a maximum 1" off the floor for maximum noise isolation. If building conditions do not allow installation with only this distance from the floor, the vendor must get a variance from this requirement before proceeding with the installation.

When assembled, panels shall be free-standing and self-supporting; no connections to the walls, ceiling or floor shall be made without agreement with agency representative.

The dimensions and layout shall be as indicated on drawing included with the specifications. Drawings must be furnished by the vendor so the agency has a clear understanding of their purchase; panel sizes shall be as listed in the specifications. The vendor shall be responsible for verification of component quantities and sizes as set forth.

SYSFURN07 – Statewide Contract Specifications for Office Furniture

4. Construction

a) Frame

The frame shall be constructed in such a manner that it will support hang-on components, work surfaces, etc. with attendant loads, without warping, bending, flexing or breaking.

b) Fabric Covering

The fabric shall be applied smoothly and wrinkle free and the weave shall be straight with the panel. It shall be attached to the frame by a removable spline or other satisfactory method that will allow removal and replacement of fabric as required. No seams or fabric joints shall be visible in faces of panels unless required for special designs. Bidders shall not offer fabrics that do not meet Class A Flammability Requirements.

c) Vertical Support Standards

The standard shall be capable of supporting a worktop with two hanging pedestals loaded in accordance with “work surfaces with supported drawers’ test ANSIIBIFMA X.5.6 1993) and meeting the acceptance level specified. Work surfaces shall be adjustable in height within a minimum range of 25”-40” in increments no greater than 1-1/4”.

d) Wire Management

Panels shall be supplied in style A, communications, or B, electrified as described below.

Style A communications panels shall be communications panel with raceway to accommodate electric and/or communications cables to allow passage to adjacent panels.

Style B panels shall be electrified panels with raceways and a minimum of two pre-wired electric outlets on each side.

The raceway shall be able to accommodate all power requirements specified and 8 – 10 minimum Cat 5 or Cat 6 cables.

Style A and B panels shall also serve as in-feed panels equipped with a means of concealing cables entering from the ceiling, walls or floor.

SYSFURN07 – Statewide Contract Specifications for Office Furniture

All Style B electrified panels shall have an eight-wire, four circuit supply. All electrical components shall meet current UL and local code requirements. If the electrical system is an 8 wire UL approved, it is acceptable.

e) Panel Connections

All panel connections and perimeter framing components are to be fastened by interlocking concealed connectors and shall have smooth, tight fitting connections. No special tools shall be required for assembly or dismantling.

All connections between adjacent panels in straight runs and at intersections shall be light proof.

f) Components.

All components of panels, e.g. clips, splines, connectors, feet, posts, levelers, etc., shall be of manufacturer's standard inventory and shall be available for purchase by the user for the life of the system.

NOTE: If panels do not come from factory with electrical installed, dealer will install as required per specifications – for both Type I (Acoustical panels) and Type II (Non-Acoustical panels).

Note: All panels – including non-tackable – must be class "A" fire rated.

B. SPECIFIC REQUIREMENTS FOR PANELS

1. Design

Type I panels shall have fabric covering on both sides. The manufacturer's standard trim shall be furnished. Type II panels may be offered with or without fabric covering as specified.

2. Sound Absorption

The sound absorption rating for Type I panels shall be a minimum N.R.C. of .65 for the entire surface area of the panel, when tested in accordance with ASTM C423, latest edition. (See Section VI, Acceptance Evaluation and Quality Assurance.) Note: This sound absorption is mandatory for acoustical panels.

C. GENERAL REQUIREMENTS FOR FURNITURE COMPONENTS

1. Panel System

SYSFURN07 – Statewide Contract Specifications for Office Furniture

The panel system shall be as specified above to accommodate the components required and provide the necessary stability to make the system both safe and durable and to provide a comfortable and convenient workstation.

2. Worktops

Worktops shall be at a minimum 1-1/8" thick lumber core, minimum 1-1/8" thick 45 lbs/cu. density flake board core, or minimum 1-1/8" thick plywood core. All worktops shall be surfaced with decorative thermosetting high-pressure plastic laminate meeting NEMA- LD3 requirements.

The top shall be rounded, or soft vinyl durable edged, securely applied. Provision shall be made in the worktop to accommodate the routing of electrical cords and cables from tabletop devices and hang-on devices to the electrical and communication outlets in the panels in a safe and orderly manner. This may be accomplished by holes w/grommets, cutouts in the worktop adjacent to the panel, cable management troughs, or other approved means.

3. Glides

All components resting on the floor shall have rustproof adjustable glides.

4. Construction

Methods and processes shall be in keeping with good industry practice and the system shall provide a safe, durable and convenient workstation for the purpose intended. Hanging components shall have adjustable mounting height

5 Locks

All drawer and door units shall be equipped with individual locks or central (master type if requested), locking system meeting ANSI/BIFMA X5.6 latest edition.

6. Safety

All hanging components must meet ANSI/BIFMA's Component Dislodgement Test.

SYSFURN07 – Statewide Contract Specifications for Office Furniture

7. Electrical Attachments

All electrical attachments that may be furnished with the office systems covered in this specification shall be UL approved for use with panel systems and shall bear the UL label or nameplate.

8. Size

Sizes shall be the manufacturers' standard sizes and length shall be as required to mesh with panel standards in the location indicated.

D. General Requirements for Filing Cabinets

Specifications provide three quality levels of metal casework office furniture for use by state government agencies. Quality levels are Class A Heavy Duty, Class B Medium Duty and Class C Light Duty.

Bidders may bid selected metal office furniture that meet or exceed the minimum specifications and to provide discounted pricing on the metal standalone casework (filing and storage cabinets, desks, and credenzas) from the same model line. All furniture of the same model line shall have the same color selections available. Bids should indicate class of file cabinets bid.

The classes are:

Class A Heavy Duty, Heavy Use - Where drawers are used 25 times or more per day with a weight of two pounds per linear inch for letter size and three pounds per linear inch for legal-size drawers. Drawer suspension cycle test must pass a minimum of 100,000 cycles. All components of the suspension shall be manufactured of not less than 16 gauge steel and suspension shall be steel ball bearings.

Class B Medium, Medium Use - Where drawers are used 20 times or more per day with a weight of two pounds per linear inch for letter size and three pounds per linear inch for legal-size drawers. Drawer suspension cycle test must pass a minimum of 75,000 cycles. All components of the suspension shall be manufactured of not less than 16 gauge steel and suspension shall be steel ball bearings or nylon/celcon with steel ball bearings.

Class C Light Duty, Light Use - Where drawers are used less than 20 times per day with a weight of two pounds per linear inch for letter size and three pounds per linear inch for legal-size drawers. Drawer suspension cycle test must pass a minimum of 50,000. Vertical file cabinets have a smaller depth than those in Classes A and B.

SYSFURN07 – Statewide Contract Specifications for Office Furniture

General: All vertical file cabinets shall meet or exceed the requirements of ANSI/BIFMA X5.3 and lateral files shall meet or exceed ANSI/BIFMA X5.2 - Office Furnishing Lateral File Test.

All metal furniture shall be free from defects, imperfections, or hazards that might affect appearance, normal life, service, or user safety. All panel finishes must pass ASTM D-3359 Method B Classification 5B for adhesion and ASTM-3363 for hardness, or meet or exceed ANSI/BIFMA X5.6-2003

All welds shall be sound and without porosity. Exterior welds shall be smooth and interior welds shall have no sharp edges or rough surfaces. Welds, rivets and braces shall assure rigidity, strength and proper alignment.

File cabinets shall have one piece or utilized construction. If modular construction is used, each module shall be unitized. File cabinets shall not tilt or deviate from a true vertical state.

Vertical File Drawer Construction: The drawer shall have a positive acting spring latch capable of holding loaded drawer closed at any tilt angle; this latch shall have free movement only in the horizontal plane parallel to the drawer front. The release button shall fit snugly to the drawer front and shall be located conveniently to the drawer pull.

A label holder shall be located in center of drawer front above the drawer pull.

The follower shall have not more than 3/4" maximum increment movement, and shall be easy to adjust.

Locks shall be provided where requested.

Lateral File Drawer Construction: The cabinet front, sides, back, top and interior members (drawers and shelves) shall be manufactured of not less than 22 gauge steel, rigidly formed, braced, and welded to withstand heavy usage without distortion, warping or twisting. Drawers and roll-out shelves shall operate on full ball-bearing progressive suspensions. Members of the suspension shall be cold drawn steel, zinc plated or other suitable material to prevent rust, and of adequate strength to support loaded shelves or drawers. Suspension shall accommodate uneven drawer loading and uneven push or pull forces when opening or closing. Drawers and shelves shall operate smoothly without noticeable sticking or uneven motion. Lateral files must comply with ANSI/BIFMA X5.2, Sections 4,5,6,7,8,9,10,11,12,13 and 14.

The drawer shall have a positive acting spring latch capable of holding loaded drawer closed at any tilt angle; this latch shall have free movement only in the horizontal plane parallel to the drawer front. The release button shall fit snugly to the drawer front and shall be located conveniently to the drawer.

SYSFURN07 – Statewide Contract Specifications for Office Furniture

File Cabinet Paint Colors: For each model line available on this contract, all paint colors listed in the manufacturer's published catalog as available for that model/series are to be available at the base price offered herein, without up charges.

E. CONSTRUCTION OF INDIVIDUAL COMPONENTS

1. Worktops

For the purposes of this specification, a "worktop", or "work surface" is defined as a single unit of construction with properties as set forth in Section III.C.2 of this specification. The worktop shall be so constructed that hanging drawer units may be attached underneath the top. Worktop shall meet requirements of static load test for work surfaces of ANSIIIBIFMA X5.6 latest edition.

The worktop shall be supported at each end by one, or more, of the following means, and may be mounted by employing any one, or more, of the following methods.

- a) End clip attached to panel vertical support standard
- b) Floor-standing pedestal
- c) Cantilever bracket
- d) Floor-standing leg, with bracket(s) to attach worktop to vertical support standard. When floor-standing leg is used, the installation of such shall not restrict, or interfere with the movements of the occupant.
- e) A combination of any of the above. Ex: Floor-standing pedestal with cantilever bracket, end clip, leg, or a second floor-standing pedestal.

Worktops 72", or greater, which have an unsupported span of 66", or greater, shall have at least one intermediate support. For the purposes of this specification, "intermediate support" is defined as: a) Floor-standing pedestal, b) Cantilever bracket or c) Floor-standing leg. All worktops shall be adequately supported to prevent sagging.

2. Hanging Pedestal Drawer Units

The pedestal units shall be steel, provided with a method of secure fastening to the underside of the worktop. Drawer fronts may be durable commercial-type plastic. When attached, the entire unit, pedestals and worktop shall meet the requirements of ANSIIIBIFMA Tests, Section VI. Unless otherwise specified, pedestal depth dimension shall be a minimum of 18".

SYSFURN07 – Statewide Contract Specifications for Office Furniture

3. Pedestal Drawer Units, Mobile Type or Floor Standing

The pedestal unit shall be steel, equipped with casters or shall stand on the floor as specified. It shall fit under the worktop without excessive vacant space between the pedestal and top. The units shall meet the requirements of ANSI/BIFMA Tests, Section VI. The pedestal depth dimension shall conform to the surface depth dimension.

4. Hanging Binder Cabinet

The unit shall be front opening cabinet for storing ring binders. It may be equipped with doors hinged at top or bottom with lid supports to prevent accidental dropping of the front, or it may be equipped with sliding doors. The unit may be fabric covered or in other materials. It shall meet the requirements of ANSI/BIFMA Tests, Section VI. The overall dimension front to back shall not exceed 16 1/4”.

5. Hanging Shelf Unit (Full height and half height)

The unit shall be a horizontal shelf designed to accommodate vertical dividers to be supplied when specified. It shall meet the requirements of ANSI/BIFMA tests, Section VI.

6. Power Poles

Unless otherwise specified, in feed from the ceiling shall be through a rigid pole from the ceiling to the panel connection. Flexible in feed from the ceiling to the panel connection is not acceptable. All in feeds shall be through UL approved connectors.

7. Colors

Unless otherwise specified, the manufacturer's standard color offering shall be acceptable.

8. Paper Management

All flat shelves and storage units shall have available at least the following: Vertical shelf dividers and stacked or stacking paper bins for horizontal paper storage. All shelves, metal end supports and full height panels, for heavy-duty use must have safety locks to prevent accidental dislodgement.

9. Miscellaneous Accessories

The system shall have available accessory items for filing; coat hooks, racks, doors, etc., and will be required when specified.

SYSFURN07 – Statewide Contract Specifications for Office Furniture

F. WORKMANSHIP AND INSTALLATION

Qualification of bidders: Each bidder should include information as to the qualifications of the company, designers and installers who will perform the work. This information shall be considered and must be received prior to any award.

Contractor shall provide all labor and material necessary for a complete installation as shown on the floor plan attached to the specifications. This will include such work as leveling, installing accessories, alignment, wiring (if required), etc. Data and phone wiring will be the responsibility of the agency.

The finished installation of panel configurations shall not sway and must be clean and free from any defects, which may affect the appearance or serviceability.

Only manufacturer's standard products in design, materials, and construction, not modified versions produced for conformance to our specifications will be considered for evaluation and acceptance. Any questions concerning acceptability of the quality offered shall be the decision of the Division of Purchasing.

The entire system installation shall be in accordance with the manufacturer's guidelines for a safe and stable system. However, any deviation from the standard specification to achieve a safe and stable system must be submitted for review and approval by this office.

The contractor shall be a qualified representative of the acoustical panel system manufacturer, who has specially trained installers that are thoroughly familiar with all aspects of the system.

G. Task Chairs

A demo for all task chairs purchased through this contract must be made available for employee/ workstation tryout for a minimum of three working days. Chairs purchased without this "tryout period" are subject to return without charge.

All task chairs must have the following adjustable features:

1. Seat pan height
2. Back depth/seat depth – either through a seat slider or back depth adjuster or equivalent
3. Back or lumbar support height adjustment
4. Arm height

SYSFURN07 – Statewide Contract Specifications for Office Furniture

All task chairs that are sold as “ergonomic” chairs **MUST** have the following adjustable features:

1. Seat pan height
2. Seat pan angle
3. Back Depth/seat depth – either through a seat slider or back depth adjuster or equivalent
4. Back or lumbar support height adjustment
5. Back angle
6. Arm height
7. Arm width – both inward and outward from center line of the arm.

NOTE: Items 6 and 7 on the ergonomic chairs may be waived **IF** the purchaser does not wish to have arms on the chair being purchased.

IV. WARRANTY

The vendor warrants to the owner that all equipment furnished under this specification will be new, of good material and workmanship, and agrees to replace promptly any part or parts which by reason of defective material or workmanship shall fail under normal use, free of negligence accident, for the periods from date of acceptance, as outlined below:

- A. Structural Frames: Life of system (for as long as the user owns the system)
- B. Fabric: One Year
- C. All Other Components: Ten years

Such replacement shall be free of any charge to the owner or his representative. For the purpose of this warranty, normal use shall be defined as the use in state office building with climatic conditioning equipment operated as directed by State policy, e.g. air conditioning or heat turned off during weekends creating wide temperature and humidity variations.

Failure shall include, but not be limited to, warped, broken, or separated frames, separation of vertical support standards from frame, disfigurement or enlargement of slots in vertical support standards, warping or separation of joints in wood products, sagging or warping of work surface failure or separation of laminate from work surfaces and trim, separation of edging material from work surface edges, and any other failure which would make the system unsatisfactory for its intended use.

SYSFURN07 – Statewide Contract Specifications for Office Furniture

V. SERVICE, PARTS, AND MANUALS

At least one owner's manual shall be supplied with each installation. The complete assembly and disassembly instructions for panels, including all necessary parts lists and diagrams for future installation must be included. The manufacturer of the furniture panel system offered under this specification shall have a qualified, trained representative in the owner's area available to relocate and repair the panel systems acquired under this specification. The vendor shall provide training to representatives of the owner encompassing installation, takedown, repair and maintenance of panel systems as required. If this is requested, the vendor should provide, but must inform the agency representative that the warranty may be voided if a qualified representative does not work on the panel system.

VI. ACCEPTANCE EVALUATION AND QUALITY ASSURANCE

An acceptance inspection of the installation will be performed when specified by the agency or his representative.

Under this specification, all prospective bidders of furniture shall provide manufacturer's certification of in-house testing results or independent testing results for ANSI/BIFMA, ASTM E-84, and ASTM C423 testing. Manufacturer's certification shall be in the form of a corporate officer providing certification on corporate letterhead that the model line (by name) meets all required testing and the test results are available upon request.

All test results shall meet or exceed the applicable test requirements. Tests must be performed on the actual system offered for bid. If the manufacturer should change or modify the construction of open plan office system, the manufacturer shall notify the Purchasing Division of any change in the commodities failure to comply with the required testing and/or provide new certified testing results. The vendor shall be responsible for performance of all test requirements specified herein.

The following publication, latest issue, contains the applicable ANSI/BIFMA Tests:

ANSI/BIFMA X5.6-1993 American National Standard Tests for Office Furnishings-Panel Systems Tests.

The following tests are required:

- Section 4 - Stability Test for Panel System Products
- Section 5 - Mechanical Strength Test For Panel Systems Products
- Section 6 - Static Load Test for Storage Shelves
- Section 8 - Cabinet Tests: 8.2, 8.3, 8.4, and 8.5
- Section 11 - Static Load Test for Work Surfaces
- Section 12 - Work Surfaces With Supported Drawers Test: 12.2, 12.3, 12.4, 12.5, 12.6
- Section 13 - Dislodgement Test for Panel-Mounted Components

SYSFURN07 – Statewide Contract Specifications for Office Furniture

ASTM-C423, Sound Absorption and Sound Absorption Coefficients by the Reverberation Room Method. ASTM-E84, Test For Surface Burning Characteristics of Building Materials

Acoustical tests for noise reduction coefficient ratings shall be by ASTM-C423 Sound Absorption and Sound Absorption Coefficients by the Reverberation Room Method. A minimum N.R.C .65 for the entire surface area of the panel, including raceway(s), trim (top cap), and legs, is required.

Flammability testing shall be in accordance with ASTM-E84, test for surface burning characteristics of building materials. When tested in this manner, the panel shall have a flame spread of 25 or less and smoke development of 450 or less for Class 1 or A flammability.

VII. DELIVERY

Delivery of all equipment under this specification shall be in accordance with the terms and conditions of the Request for Quotation. The vendor shall be responsible for any packing, packaging, or protection required to insure delivery in an undamaged condition. Vendor shall be responsible for installation.

Bidders may offer a separate (higher) discount for dockside delivery. But, this must be in addition to the discount shown for complete installation. **All bids must show the cost (discount from list) for total installation. Bidders shall be disqualified if only dockside delivery is quoted.**

VIII. ORDERING DATA (For Purchase and Contract Use Only)

Purchasers should exercise any desired options offered herein and should specify the following:

Title, number, and date

Panel Type (Type I - Acoustical, Type II Non-Acoustical)

Layout of the system showing communication and electrical in feed requirements for panels.

Electrical requirements (2-Circuit, 4-Circuit, dedicated circuit, etc.)

Panel sizes and styles, appropriate drawings must be provided

Hang on components.

Type II panels - specify if fabric covered or not.

Specify fabric type and color - bidders shall not offer fabrics that do not meet Class A Flammability Requirements.

If pedestal drawer units are required, specify hanging, mobile, or floor standing.

Pedestal depth dimensions to conform to work surface depth dimension.

Power pole requirements.

Color

Miscellaneous accessories that are required

SYSFURN07 – Statewide Contract Specifications for Office Furniture

Appliances requirements, such as task lights

Sample mock-up requirements.

Top cap material for panels

Task Chair requirements-purchasers must allow time for the affected employees to try the chairs. If bidding (through SYSFURN07 vendors), the users shall try chairs before obtaining bids in order to make certain bids are "equal" on task chairs. Task chair purchasers must indicate if they require an "ergonomic" chair", but the demo is required for any task chair.

Bidder and user responsibilities for installation of the system.

Notes:

Add-On to Existing Configurations

Agencies are permitted to contact the brand specific contract holder for systems that require additional items being added to existing systems for matching and functionality purposes.

New Configurations

Any new installation in un-occupied space (or where matching is not a factor) requires three (3) bids from contract holders. An award shall be issued to low bidder meeting the agency specifications for that bid.

IX. Miscellaneous Information

Delivery Time: Vendor shall provide the current delivery time from receipt of order. Upon receipt of a contract order, the vendor is to notify (within 5 work days) the purchaser of the delivery time frame. Vendor shall coordinate the delivery and installation times with the purchaser.

Transportation Charges: All items shall be delivered FOB to any West Virginia destination with all transportation charges included.

Inside Delivery: The vendor is to provide all labor and equipment to deliver, un-crate, assemble (if required), set in place ready for agency to use in desired location as determined by the purchaser, and remove all packing materials from the job site. The vendor is to coordinate the installation with the state agency's contact person for the installation.

Design/Reconfiguration Charge: (If any; some firms do not charge a fee for design – either original or reconfiguration.) If the agency makes a written request for the vendor's design assistance, the vendor may charge an hourly fee for the on-site services. Vendor's design fee is limited to \$30.00 per hour with a \$500 maximum per project. The design fee is to be reviewed and accepted by the using agency. In a Request for Quotation, (outside any contracts issued) the agency is not obligated to a bidder for any costs incurred in the submission of a bid. **List your fee on Exhibit A.**

SYSFURN07 – Statewide Contract Specifications for Office Furniture

Move Fee: This hourly fee for moving systems shall be a maximum of \$30.00. Moves required after 5:00 p.m. and/or on weekends shall be a maximum of \$45.00/hour. If your hourly rate is less than \$30.00, the overtime rate shall be one and one-half times the hourly rate shown on your bid documents.

Note: This No installation fee shall be charged at the initial installation. Purchase price includes all installation fees. **List your fees on Exhibit A.**

Price list and catalogs: The vendor shall agree to supply and deliver descriptive literature to the agencies at no charge. The descriptive literature shall include furniture catalogs and price lists for the model lines awarded on this contract. Discount from list will be firm for life of the contract; including any renewals. New manufacturer's catalogs will be considered at renewal anniversary dates. Vendor shall respond to calls and inquiries within three business days of the initial contact by the agency.

Invoicing: The vendor's invoice shall include an itemized listing of the components supplied and installed at the agency location. Vendor's invoice must list the quantity, description and model number, page number on which the model number and price can be found, unit price, and the total price. This is a mandatory requirement and is necessary for the Agency and State Auditor to confirm the pricing of each component.

Vendor's Performance: All users of this contract are requested to report in writing to the Purchasing Division any serious problems encountered with the performance, quality, and workmanship of items or performance of the successful vendor to supply and properly warrant the equipment furnished hereunder.

Reports: Vendors who are awarded contracts shall provide quarterly reports of orders as a result of this contract by both state and political sub-divisions within the State of West Virginia. Reports shall indicate the ordering agency, date and total value. Additionally, an annual composite report listing total value and total number of orders for all state agencies and political subdivisions shall be required.

NOTE: All successful vendors shall be required to meet this requirement on SYSFURN07.

Correctional Industries: The State of West Virginia Department of Corrections is authorized to furnish and supply office furniture to the state agencies. It is not the intent of this contract to supercede the rights of the Department of Corrections. All state agencies are to contact the WV Department of Corrections, Prison Industries to determine if the same or similar item is available from the Department of Corrections prior to purchasing items through the statewide contract.

Ordering Procedure: Note: A detailed design and a price quote must be submitted to and approved by the agency prior to issuing any order. If the design is for new quarters (not an expansion of existing system cubicles), agencies must prepare specifications and seek a minimum of three bids. The award shall be to low bidder meeting

SYSFURN07 – Statewide Contract Specifications for Office Furniture

specifications. Bids must also be obtained if the system cubicles will be installed on a different floor

Purchases of \$100,000 or less: State Agencies shall issue a WV39, Blanket Release Order to the contract Vendor for the desired item(s) after meeting bidding requirements of for new area.

Purchases in excess of \$100,000: Purchases in excess of \$100,000 will be reviewed by the Purchasing Division. At the discretion of the Director of Purchasing, or his designee, these requirements may be bid on the open market.

Payment: The State of West Virginia agencies may make purchases on the State Payment Card (VISA) for purchases with a maximum value of \$2,500.00. Vendor's invoice must list the quantity, description or model number, page number on which the model number and price can be found, unit price, and the total price.

Evaluation of Bids:

To facilitate meeting the furniture needs of the West Virginia State Agencies this shall be a multiple award contract for furniture; one contract per manufacturer, insofar as possible.

It is the bidder's responsibility to document that all furniture offered is equal to or exceeds the specifications.

Bidder may bid one or more manufacturer's catalog/price list, model line and number, showing discount from list for each. Each bid must contain a "full service line", system panels, cabinets, chairs, etc.

The attached Exhibit A must be completed showing discount/multiplier being offered for each brand and line of furniture to be bid. Please type, using excel document to be provided after the mandatory pre-bid meeting.

Notes:

- 1. All awards will be made based on discount from list. No exceptions to discount from list.**
- 2. All catalogs/lines bid must be on this list.**
- 3. Bidders should submit Exhibit A on a diskette or CD with their bid.**
- 4. If you are bidding the entire catalog, simply identify the catalog. Each line in such catalog does not require listing UNLESS the discounts from list vary from line to line.**

Bidders are requested to type the exhibits. If any discrepancy exists between the paper and the electronic file, the hard paper copy shall prevail.

SYSFURN07 – Statewide Contract Specifications for Office Furniture

RFQ Schedule

Release of the RFQ	July 27, 2006
Pre-Bid Conference	August 16, 2006 – 11:00 a.m.
*Vendor's Written Questions Submission Deadline	August 14, 2006
Response to Questions/Addendum Issued	August 29, 2006
Bid Opening Date	September 20, 2006

Vendor: Access Systems	Spending Unit:
------------------------	----------------

Requisition No.: _____

ADDENDUM ACKNOWLEDGEMENT

I hereby acknowledge receipt of the following checked addendum(s) and have made the necessary revisions to my proposal, plans and/or specifications, etc.

Addendum No.'s:

No. 1 X

No. 2 _____

No. 3 _____

No. 4 _____

No. 5 _____

I understand that failure to confirm the receipt of the addendum(s) is cause for rejection of bids.



Signature

Access Systems

Company

9/20/06

Date

COMMERCIAL TERMS AND CONDITIONS

PRICES

FOB Shipping Point, Fairfield, Ohio 45014. Prices and shipping points subject to change without prior notice.

TERMS

Net 30 days from date of invoice.

DESTINATION INSPECTION

Merchandise should be fully inspected upon receipt for any evidence of damage or shortage before acceptance. If shortage or damage occurs, refuse acceptance until a transportation agent endorses extent of damage or shortage. Transportation agent notification must be made within 10 days of delivery to your premises. Call your Representative and notify him/her of the damage or shortage.

If external appearance has not indicated damage, but upon opening, contents are found damaged, unpacking should be stopped and an inspector of the delivering carrier immediately called. All cartons should be saved for inspection. The inspector should indicate on the delivery receipt the exact condition of the contents. Notify your Representative of the damage.

Your cooperation on damaged shipments will help us to promptly replace the damaged product, and protect our mutual rights against the transportation carrier.

INSTALLATION

Prices do not include installation, freight or inside delivery. Contact your local Representative for assistance in determining charges for those items requiring inside delivery and/or installation.

REPAIRS AND ADJUSTMENT

Claims for repairs or adjustments will not be accepted unless authorized in advance by TAB.

WARRANTY

All products are warranted to be free from manufacturing defects under normal use in their unaltered condition for a period of ten (10) years from date of purchase. **The following moving parts are warranted for three (3) years from date of purchase: slides, locks, casters, adjustable keyboards and tasklights.**

CANCELLATION AND CHANGE POLICY

Orders as described in this section cannot be changed or canceled after the order is acknowledged. Call Customer Service for information 800-827-3288.

INTERNATIONAL OPERATIONS

Overseas Representatives in Major Areas. Prices subject to change without notice.

GSA TERMS AND CONDITIONS

I. TABLE OF AWARDED SPECIAL ITEMS NUMBERS

- Special Item No.
711-2 Worksurfaces, Workstations, Computer Furniture, Accessories
711-3 Filing and Storage Cabinets
711-11 Conference Tables
711-94 Design/Layout Services (~~\$80~~ per hour) *for*
711-92 Installation Services (negotiated each contract)

2. MAXIMUM ORDER LIMITATION (MOL)

Maximum dollar value order is \$500,000 net product cost

3. MINIMUM ORDER

Minimum dollar value order to be issued under this contract is \$100 list

4. GEOGRAPHIC COVERAGE (Delivery Area)

Geographic coverage of this contract is the 48 contiguous states and the District of Columbia

5. POINT OF PRODUCTION

Fairfield (Butler County), Ohio

6. DISCOUNTS FROM LIST PRICE

All contract items are net of minimum applicable discounts

7. QUANTITY DISCOUNTS

Order Size
At List Price
\$0-\$60,000
\$60,001-\$500,000

Discount

40% *of*

8. PROMPT PAYMENT TERMS

1% 20 days, Net 30 days from date of invoice for all items.

9a. GOVERNMENT COMMERCIAL CREDIT CARD WILL BE ACCEPTED

9b. DISCOUNT FOR PAYMENT BY GOVERNMENT COMMERCIAL CREDIT CARD

No additional discount.

10. FOREIGN ITEMS

No foreign product items are included.

11. TIME OF DELIVERY

Within 90 days ARO.

12. FOB POINT

Prices listed in this contract are FOB destination. Shipments outside the geographical coverage are FOB Port of embarkation continental U.S. Inside delivery is included in destination freight charges if requested at time order is placed. Installation is not included in destination freight charges.

13 ORDERING ADDRESS

Hamilton Sorter
c/o Participating Dealer
3158 Production Drive
Fairfield, OH 45014
Telephone: 513-870-4400
Fax: 513-870-4401

14. PAYMENT ADDRESS

Hamilton Sorter
2504 Pay Sphere Circle
Chicago, IL 60674-2504

15. LIMITED LIABILITY

Hamilton Sorter (Workstream) products except those products or parts noted below, are warranted to be free from defects in design, materials and workmanship for a period of ten (10) years from the date of acceptance. During the warranty period, all defective product will be repaired or replaced at Hamilton Sorter's expense, including parts, labor and transportation. The following products and parts are warranted for three (3) years from the date of acceptance: tackboard fabric, tasklights, multiple outlet power strips (MOPS), casters and adjustable keyboards.

The warranty is not applicable if any of the following conditions exist:

- damage occurs after the product has been received free and clear with no exceptions noted.
- damage results from accident, negligence, misuse or fault of a customer/user.
- products are built to customer specifications (specials)
- product is modified after acceptance.
- attachments are made of/to other manufacturer's products
- installation was not performed or approved by an authorized Hamilton Sorter dealer.
- persons not approved or authorized by Hamilton Sorter have moved, installed, modified, altered, replaced or repaired the product.

Except as stated above, Hamilton Sorter makes no express or implied warranties as to any product, in particular, makes no warranty of merchantability or warranty of fitness for any particular purpose. Our sole and exclusive obligation under this warranty is to repair or replace defective products or, at our option, to pay the reasonable cost of repair or replacement or issue credit. Hamilton Sorter shall not be liable for incidental or consequential damages, for lost profits or sales, or damages for injuries to person or property.

16. CHANGES/CANCELLATIONS/RETURNS

Orders may not be changed or canceled without written consent. Orders for non-standard or modified products may not be canceled. Cancellation or change requests must be submitted within three (3) working days after receipt of the Order Acknowledgment, providing the order has not already been put into production. A minimum charge of 20% will be imposed for changes or cancellation. The minimum charge will be increased if necessary to fully compensated us for all materials ordered, work performed, lost profits, reasonable overhead, and any other expenses resulting from cancellation or change.

Merchandise is not returnable unless written authorization is received from the factory. All transportation charges must be prepaid. Collect shipments will not be accepted. Return shipments, when accepted, are subject to a minimum 20% rehandling, restocking charge of the net invoice amount. Any open market items ordered in conjunction with the contract items will be subject to a 100% restocking fee. Our agreement to accept a return is conditional upon our inspection of the returned product.

17. EXPORT PACKING CHARGES

Not applicable

18. TERMS & CONDITIONS OF RENTAL, MAINTENANCE AND REPAIR

Not Applicable

19. TERMS AND CONDITIONS OF INSTALLATION

Negotiated on a project-by-project basis.

20. TERMS AND CONDITIONS OF REPAIR PARTS

Not Applicable

21. LIST OF SERVICE AND DISTRIBUTION POINTS

Not Applicable

22. LIST OF PARTICIPATING DEALERS

List available upon request

23. PREVENTATIVE MAINTENANCE

Not Applicable

ORDER GUIDE

PANEL COLORS

Furniture Systems offers the following color combinations for panels, posts and transition trim.

Top Cap Colors:

Fashion Grey
Slate Grey
Porcelain
Black
African Walnut
Solar Oak

FABRIC

Furniture Systems panels and tackboards are offered in two grades of fabric. Some fabric may carry a 6% upcharge from list price. See approved fabric list for upcharge information. Fabric samples are available from Guilford of Maine at 1-800-544-0200. Only fabrics on approved fabric list are available for order. Some fabrics may carry a longer lead time. Contact Customer Service, Furniture for lead times.

Standard Fabric:

FR701	Phone Tag
Belgrade	Pinball
Groove	Puzzle
Raku	
Snapshot	

6% Upcharge:

All other standard Guilford fabrics.

WORKSURFACE COLORS

Furniture System, worksurfaces will be furnished in the 13 color selections. Edgebanded worksurfaces are subject to a 20% upcharge from list price for HPL, T-Molded worksurfaces use HPL

Trim and Laminate:

Kensington Maple – old (Hard Rock Maple II)
Solar Oak
Oiled Cherry
Autumn Cherry
Woodlawn Cherry
Empire Mahogany – old (African Walnut)
Grey Moss – old (Putty)
Fashion Grey
Crystal Sandstorm
Slate Grey
Black
Graphite Nebula
Cognac

1. Specify the **color name** of the laminate.
2. Specify the **Edgeband color**.
3. **Hardware color: Black Only.**
4. **Grommets: Black Only.**

EDGE BANDED PEDESTALS, OVERHEADS, CABINETS, AND OPEN SHELF COLORS

Hard Rock Maple II
Solar Oak
Oiled Cherry
Autumn Cherry
Woodlawn Cherry
African Walnut
Putty
Fashion Grey
Crystal Sandstorm
Slate Grey
Black
Graphite Nebula
Cognac

STANDARD PAINT COLORS

Cool Grey	Porcelain
Charcoal	Chinchilla

OPTIONAL PAINT COLORS

White	Sage Green
Ruby Grey	Ivory Beige
Black	Balsam
Neutral Grey	Slate Blue
Graphite Blue	Quiet Rose
Teal	

T-MOLD COLORS

Cool Grey	Charcoal
Chinchilla	Black
Porcelain	

LOCKS FOR PAINTED ITEMS

The standard lock supplied on all components (included or optional) is a D101-AR. Special keying requirements will be field-installed issuing an available 125 lock changes, model numbers D002-AR through D313-AR. Additional locks should be ordered as a line item on the order transmittal. Control Key required to field-change locks, must be obtained from Customer Service.

LOCKS FOR EDGEBANDED ITEMS

The standard lock supplied on all components (included or optional) is a 100T-150T

Note default is 100T and all keyed alike unless specified

PANELS

Systems tackable panels feature a vinyl wrapped MDF trim. Manufactured from aluminum extrusions that are welded together in a mitered corner. The core consists of 1/4" 6 pound density wallboard and 6 pound density whisper tone wallboard. The panels are 2 1/2" thick and 2 1/2" of compressed fiberglass used to absorb sound. (NRC Rating .80) The panels have passed the ASTM E84 fire test and include top trim, raceway covers and one stanchion.

Panel bases/raceways provide a chase for communication cables and/or the installation of optional electrical components. Manufactured of painted steel, the raceway covers are specially designed to be installed without any special tools or additional hardware. Each cover has two knockouts for electrical outlets and two D shaped knockouts for wire pass through.

Panel connection is accomplished by use of a structural interconnecting stanchion. Each metal stanchion is slotted on one-inch centers for ease in mounting worksurfaces and storage units. Leveling glides are provided for leveling of the entire panel system. The load capability far exceeds BIFMA and ASTM standards.

Note: New Style top caps will not fit with older panels.

When panels are not joined in a straight line an appropriate post must be utilized. The System offers numerous configuration options including standard corners, "T" corners and "X" connections. For each surface of a post that adjoins a panel and requires a stanchion, one is provided. Except for "X" posts, and wall posts, all posts have fabric wrapped surfaces. All posts come with top trim which extends into the next panel by 4" and, if necessary, raceway covers.

Panel fabric is available in a choice of two grades. Grade 2 carries a 6% upcharge from list.

Please see the approved fabrics list.

Other Guilford fabrics are available, but must be approved by customer service and may be subject to upcharges and an extended lead time.

Panel trim is available in six colors; Fashion Grey, Slate Grey, African Walnut, Porcelain, Black and Solar Oak.

Raceway covers; Black, Porcelain and Fashion Grey.

HOW TO SPECIFY A PANEL:

Step One: Specify fabric Color. Please refer to your Fabric Card for available fabrics. Be certain to cross reference panel model number with the correct fabric grade.

Step Two: Specify Top Cap Color:

Top Cap Colors:

Fashion Grey
Slate Grey
Porcelain
Black
Solar Oak
African Walnut

Step Three: Specify Raceway Color:

Raceway Colors:

Black
Porcelain
Fashion Grey

PANELS

Description	Ship Weight in Lbs.	Model Number	Price
STRAIGHT PANELS			
<input type="checkbox"/> Specify finish color for: TOP CAP FABRIC: Type and Color Grade 2 upcharge 6% Refer to Order Guide			
29H x 18W	17	TP1829	\$278.00
29H x 24W	22	TP2429	\$306.00
29H x 30W	28	TP3029	\$339.00
29H x 36W	33	TP3629	\$367.00
29H x 42W	39	TP4229	\$401.00
29H x 48W	44	TP4829	\$430.00
29H x 60W	54	TP6029	\$471.00
36H x 18W	25	TP1836	\$323.00
36H x 24W	30	TP2436	\$356.00
36H x 30W	35	TP3036	\$392.00
36H x 36W	41	TP3636	\$425.00
36H x 42W	45	TP4236	\$461.00
36H x 48W	47	TP4836	\$496.00
36H x 60W	57	TP6036	\$536.00
42H x 18W	25	TP1842	\$353.00
42H x 24W	30	TP2442	\$388.00
42H x 30W	35	TP3042	\$413.00
42H x 36W	41	TP3642	\$467.00
42H x 42W	45	TP4242	\$508.00
42H x 48W	47	TP4842	\$545.00
42H x 60W	47	TP6042	\$585.00
48H x 18W	30	TP1848	\$383.00
48H x 24W	35	TP2448	\$428.00
48H x 30W	40	TP3048	\$469.00
48H x 36W	45	TP3648	\$510.00
48H x 42W	50	TP4248	\$554.00
48H x 48W	55	TP4848	\$613.00
48H x 60W	65	TP6048	\$652.00
62H x 18W	40	TP1862	\$439.00
62H x 24W	45	TP2462	\$489.00
62H x 30W	50	TP3062	\$544.00
62H x 36W	54	TP3662	\$594.00
62H x 42W	59	TP4262	\$645.00
62H x 48W	66	TP4862	\$699.00
62H x 60W	76	TP6062	\$733.00
66H x 18W	44	TP1866	\$464.00
66H x 24W	47	TP2466	\$516.00
66H x 30W	54	TP3066	\$542.00
66H x 36W	57	TP3666	\$625.00
66H x 42W	61	TP4266	\$681.00
66H x 48W	66	TP4866	\$736.00
66H x 60W	66	TP6066	\$771.00
80H x 18W	47	TP1880	\$519.00
80H x 24W	51	TP2480	\$581.00
80H x 30W	58	TP3080	\$647.00
80H x 36W	85	TP3680	\$708.00
80H x 42W	90	TP4280	\$630.00
80H x 48W	95	TP4880	\$839.00

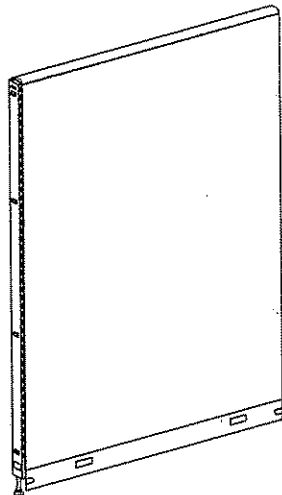

Dramatic

Architect

Studio

Eclectic

Curves

WINDOW PANELS (NOT ON CONTRACT)

Premier

Archworks

Studio

Essentials

Curves

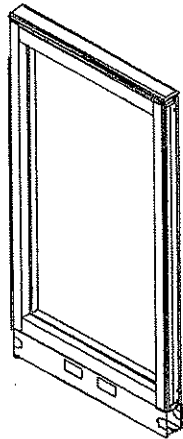

Description	Ship Weight In Lbs.	Model Number	Price
PANEL STRAIGHT WITH FULL WINDOW			
<input type="checkbox"/> Specify finish color for: TOP CAP & RACEWAY COVER PLEXIGLAS: Clear or Smoke			
62H x 24W		TPW2462-F	\$853.00
66H x 24W		TPW2466-F	\$922.00
80H x 24W		TPW2480-F	\$1,107.00
62H x 30W		TPW3062-F	\$975.00
66H x 30W		TPW3066-F	\$1,012.00
80H x 30W		TPW3080-F	\$1,268.00
62H x 36W		TPW3662-F	\$1,083.00
66H x 36W		TPW3666-F	\$1,218.00
80H x 36W		TPW3680-F	\$1,367.00
62H x 42W		TPW4262-F	\$1,182.00
66H x 42W		TPW4266-F	\$1,338.00
80H x 42W		TPW4280-F	\$1,522.00
62H x 48W		TPW4862-F	\$1,449.00
66H x 48W		TPW4866-F	\$1,539.00
80H x 48W		TPW4880-F	\$1,648.00

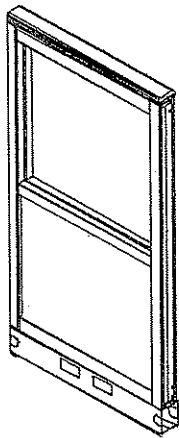

PANEL STRAIGHT WITH HALF WINDOW			
<input type="checkbox"/> Specify finish color for: TOP CAP & RACEWAY COVER FABRIC: Type and Color Grade 2 upcharge 6% PLEXIGLAS: Clear or Smoke			
62H x 24W		TPW2462-H	\$910.00
66H x 24W		TPW2466-H	\$1,004.00
80H x 24W		TPW2480-H	\$1,174.00
62H x 30W		TPW3062-H	\$999.00
66H x 30W		TPW3066-H	\$1,043.00
80H x 30W		TPW3080-H	\$1,347.00
62H x 36W		TPW3662-H	\$1,149.00
66H x 36W		TPW3666-H	\$1,293.00
80H x 36W		TPW3680-H	\$1,453.00
62H x 42W		TPW4262-H	\$1,264.00
66H x 42W		TPW4266-H	\$1,417.00
80H x 42W		TPW4280-H	\$1,617.00
62H x 48W		TPW4862-H	\$1,537.00
66H x 48W		TPW4866-H	\$1,635.00
80H x 48W		TPW4880-H	\$1,752.00

DOORS

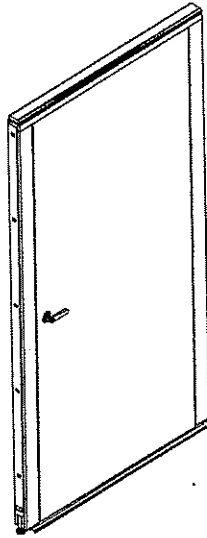

DOORS

Door Panel replaces a 42" panel. This panel is made up of a painted door frame and a 36" wide laminate door. Door panel **MUST** be placed between two panels. A door cannot be installed with a post connection or wall mount on either side. Door must be placed within 24" of a post or wall mount.

Left or right hand must be specified. The direction the door pivots away from you determines the "hand". If the door pivots from your right as you enter the doorway it is a "right hand". All door hardware is brushed chrome. Door handle is ADA compliant lever type. Door includes threshold, top trim and two stanchions.

Interior Dimension

36" wide door provides opening 32" wide
80" high panel door height is 78" high

- Specify paint color for:**
Door Powdercoat (Frame): Fashion Grey, Porcelain, or Black
- Specify laminate for:**
Door surface, from 13 standard laminate colors
- Specify trim color for:**
Door Top Trim: Fashion Grey, Black, Porcelain, Slate Grey, Solar Oak or African Walnut

Description	Ship Weight In Lbs.	Model Number	Price
80"H x 42"W Right Hand	74	TP-W202N	\$2,620.00
80"H x 42"W Left Hand	74	TP-W201N	\$2,620.00

POSTS

Premier

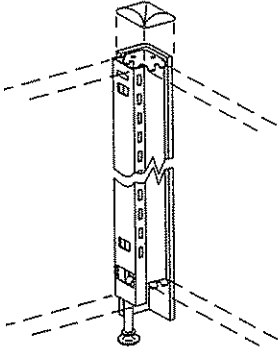

CORNER POSTS

Used to make a 90 degree turn in a panel run.

Adds 2 1/2" to the length of a panel run.

- Specify finish color for:**
- TOP CAP
- FABRIC: Type and Color
- Grade 2 upcharge 6%
- Refer to Order Guide

Description	Ship Weight in Lbs.	Model Number	Price
29H	8	TP2WAY29	\$135.00
36H	10	TP2WAY36	\$146.00
42H	11	TP2WAY42	\$153.00
48H	14	TP2WAY48	\$158.00
62H	16	TP2WAY62	\$174.00
66H	17	TP2WAY66	\$179.00
80H	21	TP2WAY80	\$193.00

Archworks

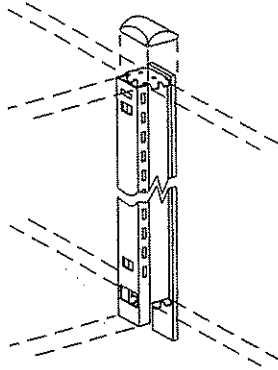

T-POSTS

Used to make a "T" junction in a panel run.

Adds 2 1/2" to the length of a panel run.

- Specify finish color for:**
- TOP CAP
- FABRIC: Type and Color
- Grade 2 upcharge 6%
- Refer to Order Guide

29H	7	TP3WAY29	\$135.00
36H	9	TP3WAY36	\$144.00
42H	10	TP3WAY42	\$148.00
48H	12	TP3WAY48	\$158.00
62H	14	TP3WAY62	\$167.00
66H	16	TP3WAY66	\$179.00
80H	18	TP3WAY80	\$191.00

Studio

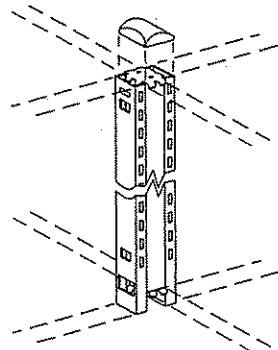

X-POSTS

Used to make an "X" junction in a panel run.

Adds 2 1/2" to the length of a panel run.

- Specify finish color for:**
- TOP CAP

29H	8	TP4WAY29	\$171.00
36H	10	TP4WAY36	\$185.00
42H	11	TP4WAY42	\$191.00
48H	12	TP4WAY48	\$200.00
62H	13	TP4WAY62	\$221.00
66H	14	TP4WAY66	\$227.00
80H	15	TP4WAY80	\$247.00

Essentials

Curves

POSTS



Description	Ship Weight In Lbs.	Model Number	Price
WALL POSTS			
Used attaching panel run to wall.			
Stanchion Only			
29H	4	TPWALL29	\$68.00
36H	4	TPWALL36	\$76.00
42H	4	TPWALL42	\$79.00
48H	4	TPWALL48	\$81.00
62H	4	TPWALL62	\$85.00
66H	4	TPWALL66	\$87.00
80H	4	TPWALL80	\$87.00

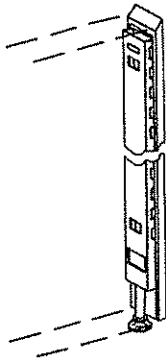

POST SIDE TRIM

Used at the end of a panel run.

Note: There is a 45 degree miter at the top.

Adds 1" to the length of a panel run.

Specify finish color for:

29H	4	TPST29	\$97.00
36H	5	TPST36	\$104.00
42H	6	TPST42	\$108.00
48H	7	TPST48	\$117.00
62H	8	TPST62	\$151.00
66H	10	TPST66	\$153.00
80H	10	TPST80	\$176.00

Premier

Archworks

Sturfin

Essentials

Curves

TRANSITION TRIM

Transition trim required when panels of different height are connected.

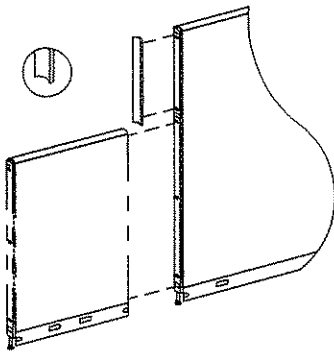

OR

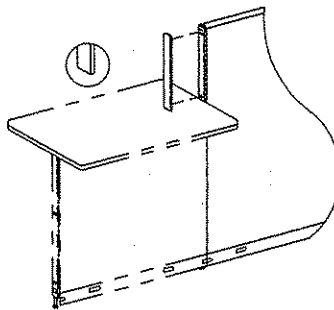

Description	Ship Weight In Lbs.	Model Number	Price
STANDARD OR STRAIGHT			
<input type="checkbox"/> Specify finish color for:			
29H To 36H	6	TPPT-7	\$66.00
29H To 42H	6	TPPT-13	\$77.00
29H To 48H	7	TPPT-19	\$89.00
29H To 62H	7	TPPT-33	\$122.00
29H To 66H	8	TPPT-37	\$126.00
29H To 80H	9	TPPT-51	\$133.00
36H To 42H	7	TPPT-6	\$66.00
36H To 48H	8	TPPT-12	\$75.00
36H To 62H	8	TPPT-26	\$106.00
36H To 66H	8	TPPT-30	\$117.00
36H To 80H	9	TPPT-44	\$126.00
42H To 48H	7	TPPT-6	\$66.00
42H To 62H	8	TPPT-20	\$90.00
42H To 66H	8	TPPT-24	\$101.00
42H To 80H	9	TPPT-38	\$126.00
48H To 62H	8	TPPT-14	\$59.00
48H To 66H	9	TPPT-18	\$85.00
48H To 80H	10	TPPT-32	\$122.00
62H To 66H	9	TPPT-4	\$63.00
62H To 80H	10	TPPT-18	\$85.00
66H To 80H	11	TPPT-14	\$77.00

Premier

Archworks

Studio

Essentials

Curves

WORKSURFACES

EDGEBANDED WORKSURFACES

Manufactured of 45 lbs. 1" medium density particleboard. All worksurfaces are finished with a double sided Thermoset Laminate finish. All worksurface sides are trimmed with 2mm PVC edgeband. All necessary mounting hardware for a standard installation is included. System worksurfaces far exceed BIFMA and ASTM standards.

T-EDGE WORKSURFACES

Manufactured of 45 lbs. 1 1/8" medium density particleboard. All worksurfaces are finished on top with a high pressure suede finish plastic laminate which results glare and scratches. The underside of the worksurfaces are sealed with a dark colored backing sheet. All worksurface sides are trimmed with vinyl T-Edge molding. All necessary mounting hardware for a standard installation is included. System worksurfaces far exceed BIFMA and ASTM standards

STORAGE

A full selection of overheads, pencil drawers, and pedestals which complement and enhance systems section.

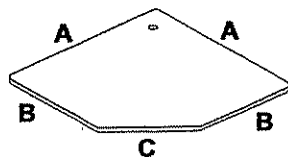
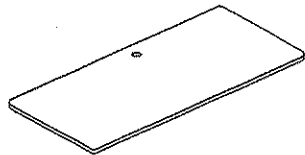

HOW TO SPECIFY A WORKSURFACE:

Step One: Specify choice for laminate top:

Edgeband: See your 12 color selections.

T-Edge: See your current Nevamar sample card or ring.

Step Two: Specify Colors:

Edgeband:

Hard Rock Maple II, Solar Oak, Oiled Cherry, Autumn Cherry, Woodlawn Cherry, African Walnut, Putty, Fashion Grey, Crystal Sandstorm, Slate Grey, Black, Cognac or Graphite Nebula.

T-Edge:

Porcelain, Cool Grey, Charcoal, Chinchilla or Black

Grommets:

Black Only.

Hardware:

Black Only.

Description	EdgeBanded Worksurface			T-Edge Worksurface		
	Ship Weight In Lbs.	Model Number	Price	Ship In Lbs.	Model Number	Price

STRAIGHT WORKSURFACE WITH STANDARD GROMMET

Specify finish color for:

WORKSURFACE, EDGEBAND AND T-EDGE

18W x 24D	18	TWS1824	\$107.00	19	TWS1824-T	\$194.00
18W x 30D	22	TWS1830	\$125.00	23	TWS1830-T	\$221.00
24W x 24D	25	TWS2424	\$112.00	26	TWS2424-T	\$197.00
24W x 30D	30	TWS2430	\$132.00	31	TWS2430-T	\$280.00
30W x 24D	30	TWS3024	\$117.00	31	TWS3024-T	\$213.00
30W x 30D	36	TWS3030	\$138.00	37	TWS3030-T	\$286.00
36W x 24D	35	TWS3624	\$123.00	36	TWS3624-T	\$223.00
36W x 30D	42	TWS3630	\$143.00	43	TWS3630-T	\$303.00
42W x 24D	40	TWS4224	\$128.00	41	TWS4224-T	\$238.00
42W x 30D	48	TWS4230	\$150.00	49	TWS4230-T	\$335.00
48W x 24D	44	TWS4824	\$133.00	45	TWS4824-T	\$242.00
48W x 30D	54	TWS4830	\$157.00	55	TWS4830-T	\$328.00
54W x 24D	49	TWS5424	\$152.00	50	TWS5424-T	\$260.00
54W x 30D	60	TWS5430	\$184.00	61	TWS5430-T	\$350.00
60W x 24D	54	TWS6024	\$157.00	55	TWS6024-T	\$280.00
60W x 30D	66	TWS6030	\$188.00	67	TWS6030-T	\$373.00
66W x 24D	60	TWS6624	\$163.00	61	TWS6624-T	\$322.00
66W x 30D	74	TWS6630	\$197.00	75	TWS6630-T	\$409.00
72W x 24D	65	TWS7224	\$168.00	66	TWS7224-T	\$363.00
72W x 30D	80	TWS7230	\$202.00	81	TWS7230-T	\$431.00

CORNER WORKSURFACES

Provided with grommet in rear corner.

Specify finish color for:

WORKSURFACE, EDGEBAND AND T-EDGE

A36 B24 C16 1/2	47	TWSC3624	\$163.00	48	TWSC3624-T	\$290.00
A42 B24 C25 1/4	59	TWSC4224	\$179.00	60	TWSC4224-T	\$375.00
A42 B30 C17	59	TWSC4230	\$197.00	60	TWSC4230-T	\$408.00
A48 B24 C30	73	TWSC4824	\$197.00	74	TWSC4824-T	\$422.00
A48 B30 C25 1/4	74	TWSC4830	\$216.00	75	TWSC4830-T	\$475.00

WORKSURFACES - EDGEBANDED

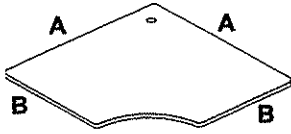

Description	EdgeBanded Worksurface			T-Edge Worksurface		
	Ship Weight In Lbs.	Model Number	Price	Ship In Lbs.	Model Number	Price

CURVED CORNER WORKSURFACES

Provided with a grommet in the rear corner.

- Specify finish color for:
WORKSURFACE
EDGEBAND or T-EDGE

A36 B24	45	TWSCC3624	\$199.00	47	TWSCC3624-T	\$331.00
A42 B24	57	TWSCC4224	\$216.00	59	TWSCC4224-T	\$383.00
A42 B30	57	TWSCC4230	\$232.00	61	TWSCC4230-T	\$398.00
A48 B24	71	TWSCC4824	\$232.00	73	TWSCC4824-T	\$398.00
A48 B30	72	TWSCC4830	\$250.00	74	TWSCC4830-T	\$416.00

CONFERENCE RUN OFFS WITH ROUND BASE

Standard mounting is perpendicular to panel run. Provides worksurface height at 29". Can be mounted on a 29" panel with special hardware (see the Accessories Section for model J733 or J734). Provides a worksurface height at 28 1/4". Can also be mounted perpendicular to worksurface with special hardware (see the Accessories Section for model 9646). Provides worksurface height at 29".

- Specify finish color for:
WORKSURFACE
EDGEBAND OR T-EDGE
BASE

48W x 30D	51	WSD4830	\$459.00	54	WSD4830-T	\$598.00
48W x 36D	66	WSD4836	\$467.00	69	WSD4836-T	\$606.00
60W x 30D	62	WSD6030	\$472.00	65	WSD6030-T	\$613.00
60W x 36D	77	WSD6036	\$484.00	80	WSD6036-T	\$621.00
66W x 30D	67	WSD6630	\$479.00	70	WSD6630-T	\$627.00
66W x 36D	82	WSD6636	\$491.00	85	WSD6636-T	\$638.00
72W x 30D	74	WSD7230	\$493.00	77	WSD7230-T	\$642.00
72W x 36D	89	WSD7236	\$495.00	92	WSD7236-T	\$647.00

P-SHAPED CONFERENCE RUN OFF W/ROUND BASE

Standard mounting is perpendicular to panel run. Provides worksurface height at 29". Can be mounted on a 29" panel with special hardware (see the Accessories Section for model J733 or J734). Provides a worksurface height at 28 1/4". Can also be mounted perpendicular to worksurface with special hardware (see the Accessories Section for model 9646). Provides worksurface height at 29".

- Specify finish color for:
WORKSURFACE
EDGEBAND OR T-EDGE
BASE

RIGHT "P" 30D W/36" DIA.

60W	74	TWSPR6036	\$486.00	77	TWSPR6036-T	\$629.00
66W	104	TWSPR6636	\$491.00	107	TWSPR6636-T	\$638.00
72W	104	TWSPR7236	\$500.00	107	TWSPR7236-T	\$638.00

RIGHT "P" 36D W/42" DIA.

72W	104	TWSPR7242	\$525.00	107	TWSPR7242-T	\$684.00
-----	-----	-----------	----------	-----	-------------	----------

LEFT "P" 30D W/36" DIA. 107

60W	74	TWSPL6036	\$486.00	77	TWSPL6036-T	\$629.00
66W	104	TWSPL6636	\$491.00	107	TWSPL6636-T	\$638.00
72W	88	TWSPL7236	\$500.00	95	TWSPL7236-T	\$638.00

LEFT "P" 36D W/42" DIA.

72W	104	TWSPL7242	\$535.00	107	TWSPL7242-T	\$683.00
-----	-----	-----------	----------	-----	-------------	----------

Premier

Archworks

Studio

Essentials

Curves

COUNTER TOPS AND SUPPORT PANELS

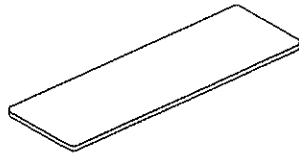

Description	EdgeBanded Worksurface			T-Edge Worksurface		
	Ship Weight In Lbs.	Model Number	Price	Ship In Lbs.	Model Number	Price

COUNTER TOPS

Counter Tops center on panels. Also used as transaction worksurface between systems workstations.

- Specify finish color for:**
 WORKSURFACE
 EDGEBAND OR T-EDGE
 HARDWARE

18W x 15D	11	TWSC1815	\$97.00	12	TWSC1815-T	\$175.00
24W x 15D	14	TWSC2415	\$102.00	15	TWSC2415-T	\$187.00
30W x 15D	17	TWSC3015	\$104.00	18	TWSC3015-T	\$202.00
36W x 15D	20	TWSC3615	\$108.00	21	TWSC3615-T	\$212.00
42W x 15D	23	TWSC4215	\$112.00	24	TWSC4215-T	\$223.00
48W x 15D	26	TWSC4815	\$117.00	27	TWSC4815-T	\$224.00
54W x 15D	29	TWSC5415	\$121.00	30	TWSC5415-T	\$246.00
60W x 15D	32	TWSC6015	\$123.00	33	TWSC6015-T	\$251.00
66W x 15D	35	TWSC6615	\$126.00	36	TWSC6615-T	\$276.00
72W x 15D	38	TWSC7215	\$132.00	39	TWSC7215-T	\$289.00

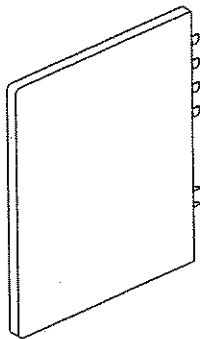

EDGEBANDED WORKSURFACE SUPPORT PANELS

Support panels provide a more finished appearance to the end of a worksurface when the end of a workcenter is left open. Two support panels are usually used for added strength and support if two hanging pedestals are installed under one worksurface. Desk height (29") support panels are available where the height refers to the top of the worksurface. TAB Furniture System. A suspended pedestal on the end of a panel run requires a support panel.

Provided in one of twelve standard colors.

- Specify finish color for:**
 EDGEBAND OR T-EDGE
 SURFACE & TRIM

DESK HEIGHT SUPPORT PANELS

24D x 29H	27	TWSL24	\$194.00	28	TWSL24-T	\$294.00
30D x 29H	33	TWSL30	\$215.00	34	TWSL30-T	\$341.00

SPECIAL WIDTH WORKSURFACES

When a standard worksurface does not fit a special application, the following program may be followed to order a custom width worksurface.* Furniture Systems can factory customize any rectangular worksurface from 18 to 72. Special sizes must be rounded up to the nearest 1". No SQ is necessary to furnish a worksurface within those dimensions. Simply follow these steps to create a custom worksurface solution:

HOW TO ORDER:

STEP 1

Determine the necessary width. Depth must be standard.

STEP 2

Round that dimension up to the nearest 1".

STEP 3

Specify the next largest worksurface model number.

STEP 4

Add the size and an "-SPL" to the model number (this will denote a special width worksurface is being ordered).

Example:

Dimension necessary is a rectangular worksurface 46"W x 30"D.

Order:

(1)WS4630-SPL

WS4630 is next largest size up from 46"W.

46 designates the 46"W and the SPL denotes a special width is being ordered

STEP 5

Add the setup charge for special width worksurface. The charge is \$35.00 per size per order regardless of the quantity ordered.

STEP 6

In the text description, give exact dimensions (to nearest 1") of the worksurface.

STEP 7

No SQ is required if the worksurface size is between 18"W and 72"W.

OVERHEAD STORAGE - METAL

Overhead storage units provide an aesthetic match with pedestal and free standing cabinets. An optional task light is recessed to maintain the clean lines of the overall workstation.

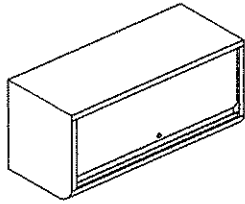

Description	Ship Weight in Lbs.	Model Number	Price
-------------	------------------------	-----------------	-------

PAINTED FLIPPER DOOR CABINET - DOOR ROTATES INSIDE CABINET

All metal construction. Lock is standard D101AR on Flipper Door Cabinet. A 60L Flipper Door Cabinet consists of two 30L units connected with special hardware for mounting on a 60W Panel. The flipper door unit also has a welded back and a standard lock for added security.

Outside dimensions 13 1/2"D 17 1/8"H
Inside dimensions 12"D; 11 7/8"H; 28", 34", 46"L

Specify paint color:
See color chart

PAINTED

24L	39	L456	\$652.00
30L	44	L457	\$666.00
36L	51	L458	\$707.00
42L	62	L459	\$752.00
48L	71	L460	\$796.00
54L	75	L449	\$1,301.00
60L	88	L461	\$1,318.00

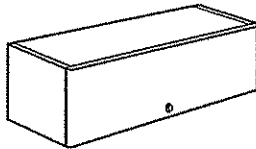

FLIPPER DOOR CABINET - OVER-THE-TOP DOOR

All metal construction. Over-the-top stowing flipper door using steel ball-bearing slides. End panels with integral mounting clips and anti-dislodgement features. Flipper door with 3/8" radius on vertical edges. Full metal back when specified. Locking flipper door using master keyed, core removable, "LL" series. Shelf stiffener on 60" units. Smooth painted and individually packaged for shipment. Shipped unassembled (knocked-down). Meets or exceeds all ANSI-BIFMA specifications.

Outside dimensions 13 1/2"D 17 1/8"H
Inside dimensions 12"D; 11 7/8"H; 28", 34", 46"L

Specify paint color:
See color chart

24L	31	TM-OH24OB	\$296.00
30L	35	TM-OH30OB	\$310.00
36L	38	TM-OH36OB	\$322.00
42L	43	TM-OH42OB	\$347.00
48L	47	TM-OH48OB	\$377.00
54L	51	TM-OH54OB	\$452.00
60L	54	TM-OH60OB	\$481.00

24L with full metal back	33	TM-OH24CB	\$404.00
30L with full metal back	37	TM-OH30CB	\$418.00
36L with full metal back	40	TM-OH36CB	\$431.00
42L with full metal back	45	TM-OH42CB	\$462.00
48L with full metal back	50	TM-OH48CB	\$493.00
54L with full metal back	54	TM-OH54CB	\$572.00
60L with full metal back	57	TM-OH60CB	\$577.00

Premier

Archworks

Strutlin

Essentials

Citrus

OVERHEAD STORAGE

Premier

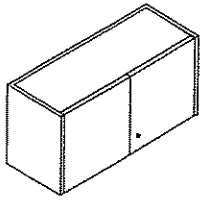

30" & 36" (2) doors

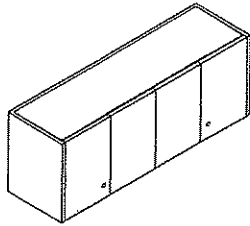

42" & 48" (4) doors

Archivark

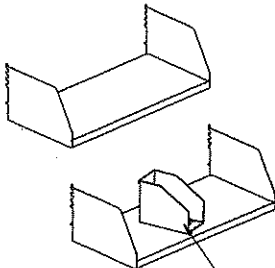

UNIT BOX SERVES AS FILE SUPPORTS
SOLD SEPARATELY

Shrink

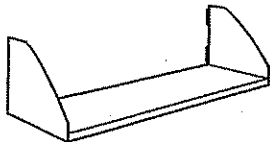

Encas

Description	Ship Weight in Lbs.	Model Number	Price
-------------	------------------------	-----------------	-------

HINGED DOOR CABINET - LAMINATE

Specify finish color:
LAMINATE: See color chart

EDGEBANDED

30L	39	TPOH30	\$407.00
36L	44	TPOH36	\$415.00
42L	39	TPOH42	\$428.00
48L	44	TPOH48	\$496.00

OPEN SHELF - LAMINATE

Outside dimensions 13¹/₂"D 14³/₁₆"H
Inside dimensions 13"D; 6⁵/₁₆"H; 28⁷/₈", 35⁷/₈", 41⁷/₈"L
Shelf sides are painted black only.
Unit box available in Equipment Catalog

Specify shelf color:
LAMINATE: See color chart

18L	23	TPOS18	\$112.00
24L	28	TPOS24	\$117.00
30L	33	TPOS30	\$121.00
36L	38	TPOS36	\$123.00
42L	43	TPOS42	\$125.00
48L	48	TPOS48	\$128.00

FULL HEIGHT OPEN SHELF - ALL METAL

Specify paint color:
See color chart

24L	26	TMOS24	\$176.00
30L	29	TMOS30	\$184.00
36L	31	TMOS36	\$190.00
42L	34	TMOS42	\$195.00
48L	38	TMOS48	\$204.00

OVERHEAD STORAGE

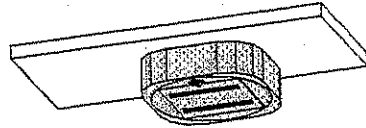

Description	Ship Weight in Lbs.	Model Number	Price
TASKLIGHT			

10" W x 10" D Black	10	PUSTL-10	\$229.00
---------------------	----	----------	----------

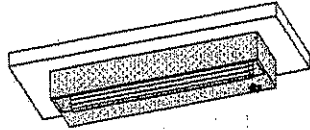

24" W x 6" D Black	10	PUSTL-24	\$153.00
California Use		PUSTL-24CA	\$173.00

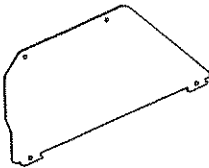

FILE SUPPORT

- Specify finish color for:
FILE SUPPORT

File Support	1	1900	\$9.00
--------------	---	------	--------

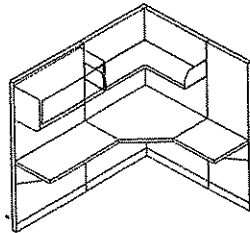

CORNER SHELF – LAMINATE

The corner shelf provides vertical storage capability above the worksurface in 90° corner applications. The shelf has a laminate surface and metal side support panels.

- Specify Color For:
WORKSURFACE:
PAINT: Pewter
LAMINATE: See color chart

30L (46½ LFI)	39	TPCS30	\$188.00
---------------	----	--------	----------

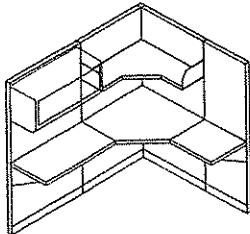

36L (58½ LFI)	47	TPCS36	\$202.00
42L (70½ LFI)	55	TPCS42	\$220.00
48L (82½ LFI)	64	TPCS48	\$238.00

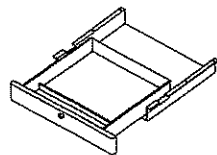

PENCIL DRAWER

Not recommended under typing height worksurface due to inadequate leg room.
Inside drawer dimensions: 13½"W x 15⅞"D x 2⅝"H.

- Specify Laminate color:

Pencil Drawer	5	AC-CD1620	\$118.00
---------------	---	-----------	----------

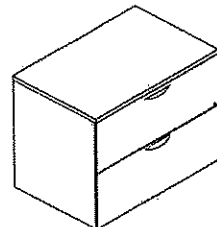

28" CABINET, WITH TWO 12" DRAWERS – LAMINATE

- Specify Paint Color For:
LAMINATE: See color chart

30" Wide x 20 Deep x 28 High used under w/s minimum 36" wide	165	TPULF30	\$644.00
36" Wide x 20 Deep x 28 High used under w/s minimum 42" wide	175	TPULF36	\$685.00
42" Wide x 20 Deep x 28 High used under w/s minimum 48" wide	185	TPULF42	\$722.00

PEDESTALS- METAL

Systems pedestals provide an aesthetic match with overhead storage units and free standing cabinets. For added security all pedestals come standard with a D101AR ganglock. Additional locks are available for field installation. See the Order Guide for details. Regardless of the exterior color, drawer interiors are furnished in neutral brown.

The 18" deep 6" Drawer has full suspension. All other 6" drawers have 3/4 suspension. One pencil tray is included in each pedestal with a 6" high drawer. If retractable power outlets are to be

included on 24" deep, only 17¹³/₁₆" deep pedestals can be specified. For 30" deep tables with retractable power outlets, only a 17¹³/₁₆" deep pedestal will fit properly.

Inside clear dimensions are:

	Width	Depth				Height
		18"	22"	24"	30"	
6" Drawer	12 ⁵ / ₃₂	15 ⁷ / ₈	18 ⁷ / ₈	18 ⁷ / ₈	24 ⁷ / ₈	5 ¹ / ₁₆
12" Drawer	12 ⁵ / ₃₂	15 ⁷ / ₈	18 ⁷ / ₈	18 ⁷ / ₈	24 ⁷ / ₈	10 ⁵ / ₈

Premier

Archworks

Sturdy

Essential

Custom

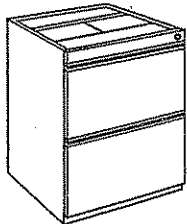
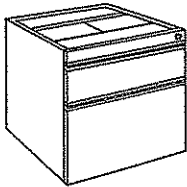

Ship Weight In Lbs.	Width	Depth	Height	Model Number	Price
------------------------	-------	-------	--------	-----------------	-------

SUSPENDED PEDESTALS

Specify Paint Color for:
PEDESTAL

6" AND 12" DRAWERS

47	15 ³ / ₁₆	17 ¹³ / ₁₆	19 ¹ / ₂	TM-PS17BF	\$427.00
54	15 ³ / ₁₆	21 ¹³ / ₁₆	19 ¹ / ₂	TM-PS21BF	\$429.00

(2) 6" AND 12" DRAWERS

62	15 ³ / ₁₆	17 ¹³ / ₁₆	25 ³ / ₃₂	TM-PS17BBF	\$542.00
69	15 ³ / ₁₆	21 ¹³ / ₁₆	25 ³ / ₃₂	TM-PS21BBF	\$548.00

(2) 12" DRAWERS

55	15 ³ / ₁₆	17 ¹³ / ₁₆	25 ³ / ₃₂	TM-PS17FF	\$476.00
64	15 ³ / ₁₆	21 ¹³ / ₁₆	25 ³ / ₃₂	TM-PS21FF	\$481.00

PEDESTALS-METAL

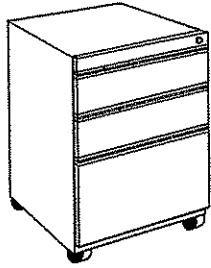

Ship Weight In Lbs.	Width	Depth	Height	Model Number	Price
------------------------	-------	-------	--------	-----------------	-------

MOBILE PEDESTALS - 27 1/2" HIGH

NOTE: 27 1/2"H Mobile Pedestal will fit under 29" high worksurfaces only.

Specify finish color for:

PEDESTAL

(2) 12" DRAWERS

73	15 ³ / ₁₆	18 ¹³ / ₁₆	27 ¹ / ₂	TM-PC18FF	\$569.00
80	15 ³ / ₁₆	21 ¹³ / ₁₆	27 ¹ / ₂	TM-PC21FF	\$583.00

(2) 6" AND 12" DRAWERS

84	15 ³ / ₁₆	18 ¹³ / ₁₆	27 ¹ / ₂	TM-PC18BBF	\$635.00
86	15 ³ / ₁₆	21 ¹³ / ₁₆	27 ¹ / ₂	TM-PC21BBF	\$650.00

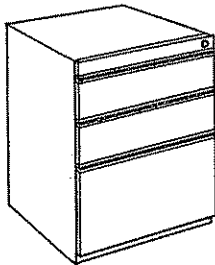

WORKSURFACE SUPPORT PEDESTALS

Provides support for 29" high worksurfaces only.

NOTE: For 24"D Modular worksurfaces specify 17¹³/₁₆" pedestals.

NOTE: For 30"D Modular worksurfaces specify 23⁵/₁₆" pedestals.

Specify Finish Color for:

PEDESTAL

(2) 12" DRAWERS

60	15 ³ / ₁₆	17 ¹³ / ₁₆	27 ¹ / ₂	TM-PD17FF	\$501.00
69	15 ³ / ₁₆	23 ⁵ / ₁₆	27 ¹ / ₂	TM-PD21FF	\$558.00
86	15 ³ / ₁₆	29 ⁵ / ₁₆	27 ¹ / ₂	TM-PD27FF	\$607.00

(2) 6" AND 12" DRAWERS

65	15 ³ / ₁₆	17 ¹³ / ₁₆	27 ¹ / ₂	TM-PD17BBF	\$571.00
74	15 ³ / ₁₆	23 ⁵ / ₁₆	27 ¹ / ₂	TM-PD21BBF	\$627.00
95	15 ³ / ₁₆	29 ⁵ / ₁₆	27 ¹ / ₂	TM-PD27BBF	\$651.00

Premier

Archwork

Studio

Essentials

Curves

PEDESTALS – LAMINATE

Systems pedestals provide an aesthetic match with overhead storage units. For added security all pedestals come standard with a lock. Box drawers feature full extension ball bearing slide for maximum drawer usage.

Premier

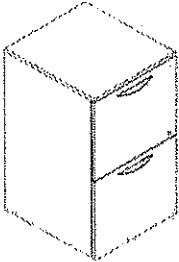

Archworks

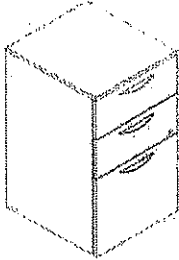

Studio

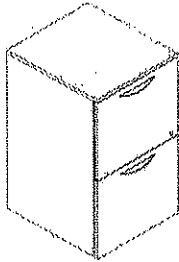

Essentials

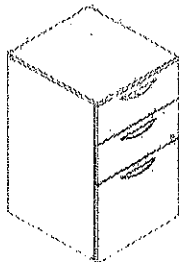

Curves

Ship Weight in Lbs.	Width	Depth	Height	Model Number	Price
------------------------	-------	-------	--------	-----------------	-------

EDGEBANDED MOBILE PEDESTALS - 28" HIGH

- Specify finish color for:
LAMINATE: See color chart
- Specify Handle

(2) 12" DRAWERS					
100	16	18	28	TPC1828F	\$483.00

(2) 6" AND 12" DRAWERS					
100	16	18	28	TPC1828B	\$447.00

EDGEBANDED FREESTANDING PEDESTALS

- Specify Finish Color for:
LAMINATE: See color chart
- Specify Handle

(2) 12" DRAWERS					
100	16	18	28	TPF1828F	\$353.00

(2) 6" AND 12" DRAWERS					
100	16	18	28	TPF1828B	\$428.00

ELECTRICAL COMPONENTS

TECHNICAL INFORMATION

System panels may be equipped with an optional electric system. The system is U.L. listed (U.L. file #E-112526 and C.S.A. certified). In order to accommodate specific customer requirements, all electric components must be specified individually.

The electrification system consists of a total of four circuits utilizing 8 wires. A 5 wire multi-wire branch circuit uses 3 lines, 1 neutral and 1 ground. (Lines I, II, & III) A totally separate 3 wire isolated and metal shielded technology circuit uses a separate clean line, clean neutral and clean ground. (Line IIII) This circuit serves desk top computers, word processors and other sensitive electronic equipment.

Non-Continuous Use

Each circuit provides a maximum of 20 amps pass through power and 15 amp service outlets. Each circuit can accommodate up to 13 duplex receptacles or a maximum of 20 amps of power draw. This is in accordance with the National Electric Code (N.E.C.). Your local code may vary.

A continuous load: of 3 hours or more requires derating the 20 amp circuit to no more than 16 amps. (ref. N.E.C.).

Example i.e., a computer, monitor and task light may require 6.5 amps as a continuous load. Two such stations equal 13 amps. (continuous). A third similar station would equal 19.5 amps, 3.5 amps over-loading. The 20 amp circuit breaker would not trip.

This overloading causes heating of the electrical parts and with time they will breakdown slowly. They may warp, reducing spacing between conductors. Eventually are between two circuits will occur, leaving a carbon trail, which will lead to more arcing. The final result will be a meltdown of conductor installation and a total fault current (short circuit). When this occurs, a nominal 5,000 amp fault current will instantly melt the conductors starting the panel on fire. The circuit breaker will/should also trip during the fault condition.

A significant safety feature of the electrical system utilized in TAB System panels is that no component, combination of components, or group of stations can be energized from more than one source of supply.

COMPONENT SPECIFICATIONS

Hardwire Ceiling Infeed - This power entry supplies power from the ceiling to the track with a 14 foot Power Entry Cable with 20 inches of

double, extra flexible metal conduit. The female connector mates the single set of male blades in each track. If the infeed is being installed in a Power Assembly (pre-assembled track and track-to-track connector combination) then the track-to-track connector must be removed to make this connection. Power can be introduced only within a core. If appropriate building power is available (220 VAC, 3 Phase) this infeed will activate all four circuits in the system.

Hardwire Receptacle Infeed - Liquidtight Flex Conduit - This power entry supplies power into a panel track through a receptacle opening in the panel raceway cover. The receptacle power entry mates the single set of male blades in every track. If the infeed is being installed in a Power Assembly (preassembled track and track-to-track connector combination) then the track-to-track connector must be removed to make this connection. The filler plate that surrounds the metal conduit fitting is off center in the opposite direction to align with the receptacle holes in the panel raceway cover. The track may be removed and flipped to allow this infeed to protrude from any of the receptacle openings in the panel raceway cover. The liquidtight flex conduit is six feet long with approximately 6-8" of bare wires for hardwire connection to building power. This infeed permits a receptacle to be placed directly on the opposite side of the panel. Power can be introduced at any point in the panel run. If appropriate building power is available (220 VAC, 3 Phase) this infeed will activate all four circuits in the system.

Hardwire End Infeed - Liquidtight Flex Conduit This power entry supplies power into a panel track without utilizing an outlet position in the track. The female connector mates the single set of male blades in each track. If the infeed is being installed in a Power Assembly (preassembled track and track-to-track connector combination) then the track-to-track connector must be removed to make this connection. The liquidtight flex conduit will exit the base of the panel through the "D" shaped knockout at the end of each raceway cover. The liquidtight flex conduit is six feet long with approximately 6-8" of bare wires for hardwire connection to building power. Power can be introduced at any point in the panel run. If appropriate building power is available (220 VAC, 3 Phase) this infeed will activate all four circuits in the system.

ELECTRICAL COMPONENTS

Plug Infeed - Provides power to split duplex receptacle line I/I only. Supplies power directly into a panel track through a receptacle opening in the panel raceway cover. This infeed permits a receptacle to be placed directly on the opposite side of the panel. The receptacle power entry mates the single set of male blades in every track. If the infeed is being installed in a Power Assembly (preassembled track and track-to-track connector combination) then the track-to-track connector must be removed to make this connection. The plug is a unique 20 amp/120 VAC plug (NEMA 5-20P) which requires a specialized and dedicated 20 amp wall receptacle (NEMA 5-20R). Supplied with a two foot infeed cable, and limited to panels runs not in excess of 30 feet. Power may be introduced an any point in the panel run. This item is not U.L. listed or C.S.A. certified.

Panel Tracks - An appropriate width panel track is included in the Power Assembly (see below). A panel track can be snapped into the base of any panel and is the basic component of the electrical system. All power infeeds, outlet modules, connectors and pass through cables attach to a panel track.

Split Duplex Receptacle Line I/I - This module snaps into the track providing two power outlets both utilizing Line I circuit. It must be used when specifying the Plug Infeed and any other application that is utilizing only the Line I circuit. This module is identified by a "I" on the face and may be placed singly or paired (back to back). A maximum of four receptacles may be placed in a panel with the exception of the 24W panel which will only accept two receptacles.

Split Duplex Receptacles - Provided in combinations of two circuits to aid in proper balancing of electrical usage. Combinations include Line I/II, Line I/III and Line II/III. These modules snap into the track providing two power outlets utilizing two different circuits. Modules are identified by a combination of I,II, and III indicated on the face. May be placed singly or paired (back to back). A maximum of four receptacles may be placed in a panel with the exception of the 24W panel which will only accept two receptacles.

Two Outlet Receptacles - These modules are similar to the Split Duplex Receptacle except that they are utilized primarily for the isolated circuit, Line III. They are available in two configurations, Line III/III and Line I/III. The first is utilized when two isolated circuit outlets are required while the second would be utilized when only one was required and the other outlet could be utilized for task lights, calculators, etc. This second option allows for the most cost effective installation when

requirements are minimal. These modules are identified by a combination of I and III with an orange triangle on the face. May be placed singly or paired (back to back). A maximum of four receptacles may be placed in a panel with the exception of the 24W panel which will only accept two receptacles.

Power Assembly - This assembly consists of a panel track of the appropriate width and a standard track-to-track connector. The track snaps into the base of the panel. The male end of the track-to-track connector snaps into an adjacent panel track and slides in the track to adjust for different panel configurations (i.e., "L," "T," "X" etc.). The male end of the Track-to-Track connector can also connect to the female end of a Pass Through Cable. Power Assemblies are available for all panel widths except 18W which must utilize Pass Through Cables. This is necessary because 18W panels cannot accept power outlet modules.

Track-To-Track Connectors - The standard track-to-track connector is included in the Power Assembly and is used to connect two powered panels together electrically.

Pass Through Cables - Pass through cables are similar to track-to-track connectors, but the female end does not mate to the track, it mates with the male end of an adjoining track-to-track connector. The male end connects to either a track or additional pass through cables. These cables are provided in 6" increments from 18" to 72" to correlate with panel widths or combinations of panel widths up to a maximum of six feet as mandated by U.L. and N.E.C. The 18" Pass Through Cable are utilized in the 18W panel which does not accept Power Assemblies or outlets.

TYPICAL POWER LOADS		
EQUIPMENT	WATTS	AMPS
CALCULATOR	30	0.25
COFFEE POT	1,020	8.50
PERSONAL COFFEE PLATE	420	3.50*
PRINTER	480	4.0*
TASK LIGHT	60	0.50
COMPUTER	240	2.0
SPACE HEATER	1,200	10.00
FAX	600	5.0*
FAN	132	1.10

SPECIFYING ELECTRICAL COMPONENTS

1. Determine the number, type and placement of all power infeed modules with an electrician.
2. Specify a Panel Track for the panel the power infeed will enter.
3. Determine the number, type and placement of all outlet modules with an electrician.
4. Specify a Power Assembly for all panels containing outlet modules.
5. Specify, if necessary, any Pass Through Cables for panels that do not contain outlet modules.

Certain cities or localities have special codes that may be more restrictive than the National Electric Code and may limit the use of some products within this system. Contact your local TAB Systems representative for clarification.

A typical workstation will be equipped with two or three duplex receptacles, dependent upon

the electrical, lighting and electronic requirements. One-and-a-half amps of current draw is assumed by the National Electric Code from each receptacle. To keep within 20 amps maximum when using 100% line capacity place no more than 16 amps on each of the three circuits. Many types of computer equipment use significantly more power than normal and special care should be taken when specifying outlets for this equipment. See the Specification Guide for further guidelines on electrical component specification.

Computer Applications

For applications which call for intensive usage of computers and other sensitive electronic equipment other power configurations and specialized outlets are available.

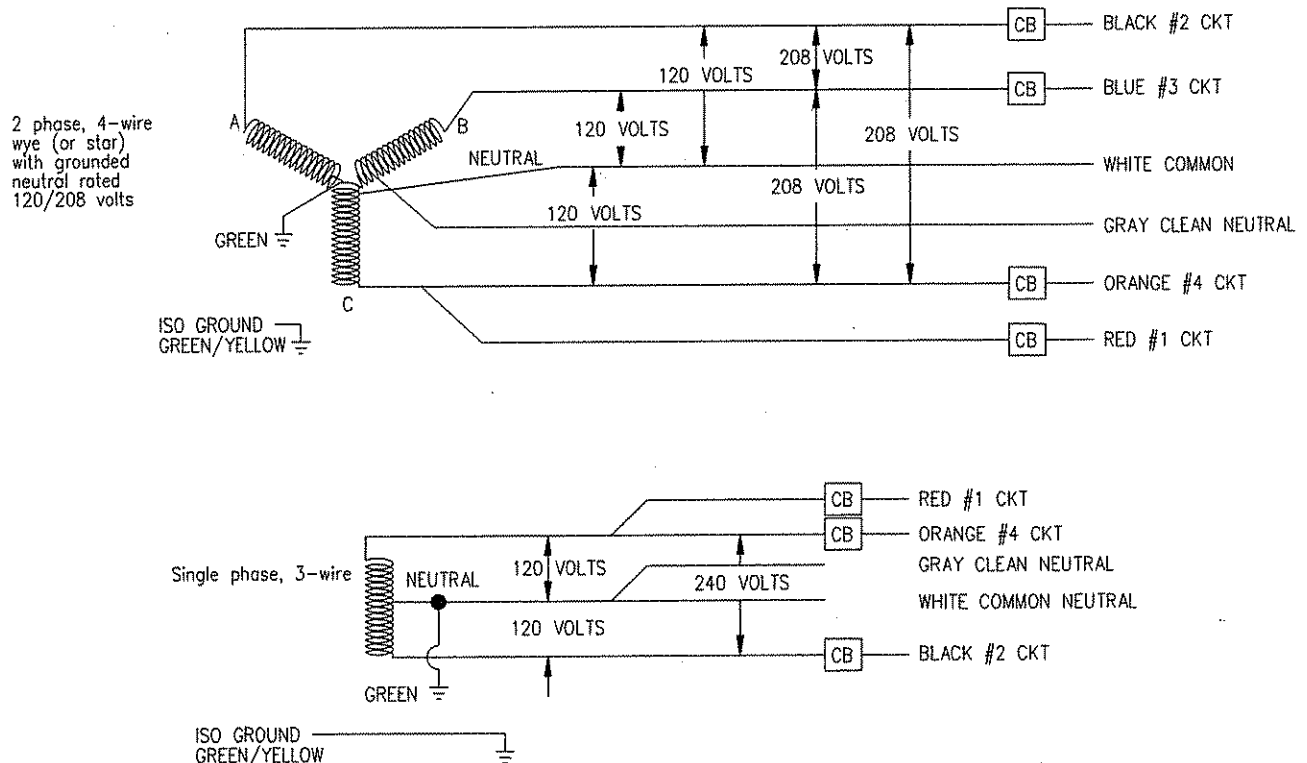

ELECTRIC SYSTEMS

TYPICAL STRAIGHT PANEL ELECTRIFICATION

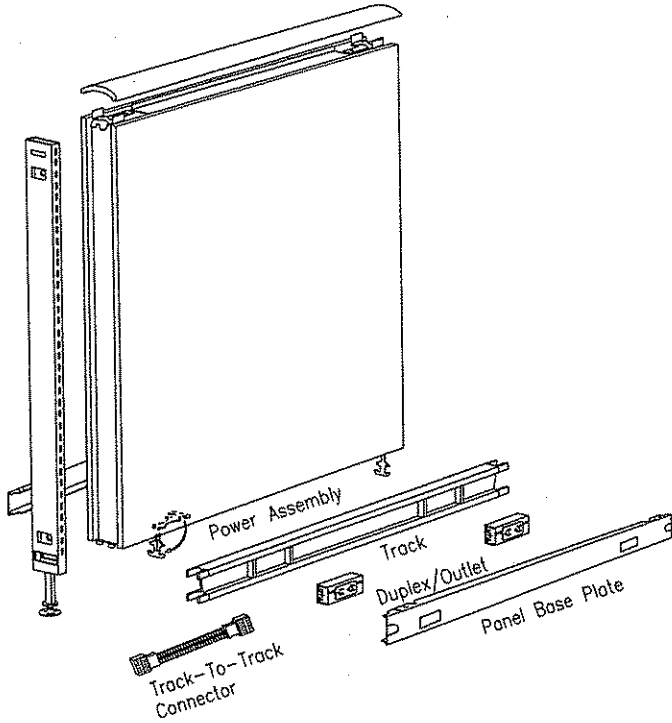

Cross section of a panel depicting the available area for cable management. This cable management space is .83 square inches (as shown in the shaded area) on each side of the panel.

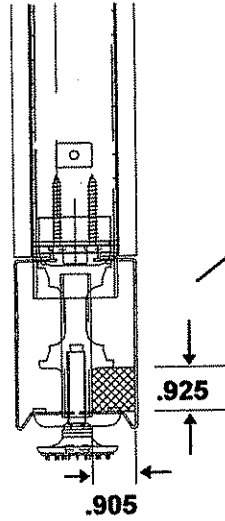

Premier

Architect

Client

Contractor

ELECTRICAL COMPONENTS

STEPS IN SPECIFYING ELECTRICAL COMPONENTS

1. Determine the number, type and placement of all power infeed modules.
2. Specify a Panel Track for the panel the power infeed will enter.
3. Determine the number, type and placement of all outlet modules.
4. Specify a Power Assembly for all panels containing outlet modules.
5. Specify, if necessary, any Pass Through Cables for panels that do not contain outlet modules.

Description	Ship Weight in Lbs.	Model Number	Price
-------------	------------------------	-----------------	-------

STEP 1: DETERMINE THE NUMBER, TYPE AND PLACEMENT OF ALL POWER INFEEED MODULES.

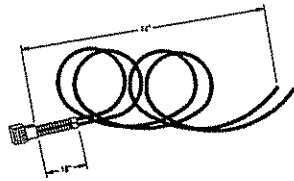

HARDWIRE POWER INFEEED MODULES

CEILING INFEEED

Utilized when power is supplied from the ceiling down a power pole in a standard system configuration. Must be hard wired into the building power source.

Ceiling Infeed	7	T9500	\$135.00
----------------	---	-------	----------

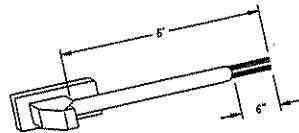

HARDWIRE RECEPTACLE INFEEED

Supplies power to the system through a receptacle opening at the base of a panel. Must be hard wired into the building power source (NOTE: Pass infeed through base plate before wiring to building power source).

Receptacle Infeed	4	T9501	\$106.00
-------------------	---	-------	----------

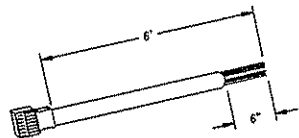

HARDWIRE END INFEEED - LIQUIDTIGHT FLEX CONDUIT

Supplies power to system without using a receptacle opening at the base of a panel. Liquidtight Flex Conduit exits from the base of the panel through the "D" knockout at the end of the raceway cover. Must be hard wired into the building power.

End Infeed-Liquidtight	4	T9502	\$107.00
------------------------	---	-------	----------



PLUG INFEEED

Supplies power to system directly from dedicated and unique 20Amp/120V plug and wall receptacle combination. This item is not U.L. listed and may not conform to local codes. This infeed activates the Line I circuit ONLY and must use the Line I/I split duplex receptacle. Supplied with a two foot cord.

3 Wire with Plug/end	3	T9503	\$104.00
----------------------	---	-------	----------

STEP 2: SPECIFY A PANEL TRACK FOR THE PANEL THE POWER INFEEED WILL ENTER.

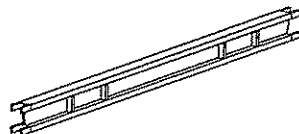

PANEL TRACKS

24W Panel Track	3	T9518	\$58.00
30W Panel Track	4	T9519	\$64.00
36W Panel Track	4	T9520	\$70.00
42W Panel Track	5	T9521	\$79.00
48W Panel Track	5	T9522	\$87.00
54W Panel Track	6	T9531	\$128.00
60W Panel Track	6	T9524	\$139.00

ELECTRICAL COMPONENTS

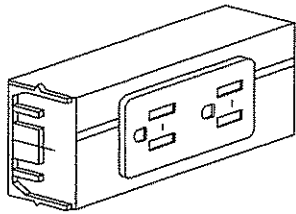

Description	Ship Weight In Lbs.	Model Number	Price
-------------	------------------------	-----------------	-------

STEP 3: DETERMINE THE NUMBER, TYPE AND PLACEMENT OF ALL OUTLET MODULES. (NOTE: TO USE SPLIT DUPLEX OR TWO OUTLET RECEPTACLES. 220 VAC, 3 PHASE POWER REQUIRED. CHECK WITH BUILDING ELECTRICIAN BEFORE ORDERING.)

DUPLEX RECEPTACLE LINE I/I

Power source for workstation user when a Plug Infeed is specified or when a system is only wired for Line I circuit. This module snaps into the track portion of the Power Assembly.

Line I/I	1	T9527	\$18.00
----------	---	-------	---------

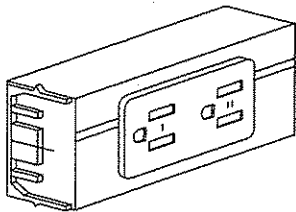

SPLIT DUPLEX RECEPTACLES

Provides power source for workstation user. Provided in combinations of two circuits to aid in proper balancing of electrical usage. These modules snap into the track portion of the Power Assembly.

Line I/I	1	T9528	\$18.00
Line I/III	1	T9529	\$18.00
Line II/III	1	T9530	\$18.00

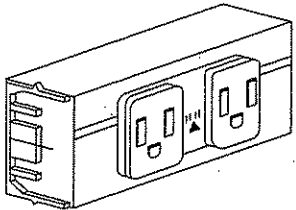

TWO OUTLET RECEPTACLES

Provide power for sensitive electronic equipment. These modules are necessary when the Line IIII (isolated circuit) is utilized. These modules snap into the track portion of the Power Assembly.

Line IIII/III	1	T9532	\$27.00
Line I/III	1	T9533	\$24.00

STEP 4: SPECIFY A POWER ASSEMBLY FOR ALL PANELS CONTAINING OUTLET MODULES.

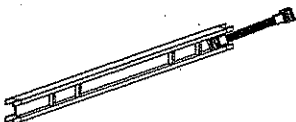

POWER ASSEMBLIES

This consists of a panel track and a track-to-track connector. Utilized when it is necessary to install outlets within a panel. All Power Assemblies except the 24W will accept up to a total of four outlet modules, two on each side of the panel. The 24W Power Assembly will accept up to a total of two outlet modules, one on each side of the panel.

24W	4	T9511	\$106.00
30W	5	T9512	\$112.00
36W	6	T9513	\$119.00
42W	6	T9514	\$128.00
48W	7	T9515	\$136.00
60W	8	T9517	\$187.00

STEP 5: SPECIFY PANEL TRACK-TO-TRACK CONNECTORS.



TRACK-TO-TRACK CONNECTORS

If you are specifying the electrical components using Power Assemblies you do not need to order any Standard Connectors or Core Interconnects. The 18" pass through cables is utilized in the 18W panels which do not accept power assemblies or outlets.

Standard Connector	2	T9525	\$50.00
18W Pnl Connector Pass Through Cable	2	T9557	\$66.00

Premier

Archworks

Studio

Essentials

Curves

ELECTRICAL COMPONENTS

Description	Ship Weight In Lbs.	Model Number	Price
-------------	------------------------	-----------------	-------

STEP 6: SPECIFY, IF NECESSARY, ANY PASS THROUGH CABLES FOR PANELS THAT DO NOT CONTAIN OUTLET MODULES.

PASS THROUGH CABLES

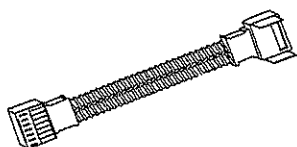

Utilized when it is necessary to pass power through panels that do not require or accept outlet modules. Manufactured to correlate with panel widths and can be used singly or in combinations up to a total of six feet in length. Provides a connection from a panel track to a track to track connector.

24W	2	T9558	\$67.00
30W	2	T9559	\$70.00
36W	2	T9560	\$73.00
42W	3	T9561	\$75.00
48W	3	T9562	\$78.00
54W	3	T9563	\$82.00
60W	3	T9564	\$85.00
66W	3	T9565	\$86.00
72W	4	T9566	\$88.00

FILLER PLATE

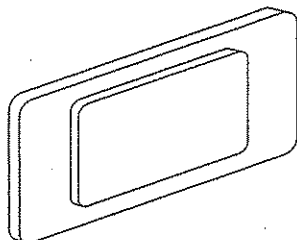

Used to fill receptacle opening in base plate if outlet module is removed. Provided in black.

Filler Plate	1	T9553	\$4.00
--------------	---	--------------	--------

PANEL BASE RETROFIT KITS

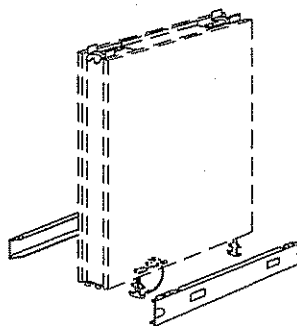

For customers with existing panels that were manufactured to accept either 5 wire or 6 wire electrical components retrofit kits are available to field modify these panels to accept 8 wire electrical components

HOSPITAL GRADE OUTLETS

Specially designed outlets required to meet Hospital Grade specifications are available on an SQ basis.

Premier

Archworks

Studio

Essentials

Curves

COMMUNICATION DATA PLATES

Description	Ship Weight In Lbs.	Model Number	Price
-------------	------------------------	-----------------	-------

COMMUNICATION DATA PLATES

Data communications access in raceway covers in the panel base, allows telephones, facsimile machines, computer networks, and other communication equipment to be used nearly everywhere you need them. Communications access provide entry to power communications cabling in the panel base, offering easy access to connection and accommodating special requirements.

Data and communication plate is a two part assembly, with a black textured plate. It adapts to fabric covered panels and does not rattle or pull out under moderate strain. It comes in combinations of singles, doubles, 1-1 combos, triples and 2-1 combos. Preconfigured cable interface modules produced by Communications Manufacturer must be purchased from their respective manufactures. TAB Products can furnish cable interface modules, when appropriate, with an SQ. Fits only in a panel without a power track.

DATA COMMUNICATION PLATES

Single - RJ11/RJ45 Coupler	1	T9626	\$5.00
Single - RJ11/RJ45 Hardwired	1	T9627	\$5.00
Single IBM Type 1	1	T9628	\$5.00
Single BNC or TNC	1	T9629	\$5.00
7/8" Opening	1	T9630	\$5.00
7/8" Plug Only	1	T9631	\$5.00
Single RS232	1	T9632	\$5.00
Double - RJ11/RJ45 Coupler	1	T9633	\$5.00
Double - RJ11/RJ45 Hardwired	1	T9634	\$5.00
Double 2BNC/2TNC	1	T9635	\$5.00
Combo - RJ11/RJ45 Coupler	1	T9636	\$5.00
Combo - RJ11/RJ45 Hardwired	1	T9637	\$5.00
Combo IBM Type II with Coupler RJ11	1	T9638	\$5.00
Combo RJ11/BNC or TNC	1	T9639	\$5.00
Combo RJ11/BNC Hardwired	1	T9640	\$5.00
Triple 3RJ11/RJ45 Coupler	1	T9641	\$5.00
Triple 3RJ11/RJ45 Hardwired	1	T9642	\$5.00
Combo - 2RJ11/RJ45	1	T9643	\$5.00
Combo - RJ11/BNC/RF45	1	T9644	\$5.00
Combo - RJ11/BNC/TNC	1	T9645	\$5.00

Premier

Archworks

Studio

Essentials

Curves

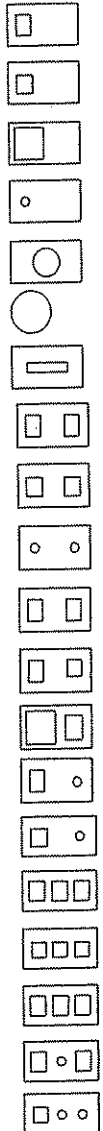

MISCELLANEOUS ACCESSORIES

Premier

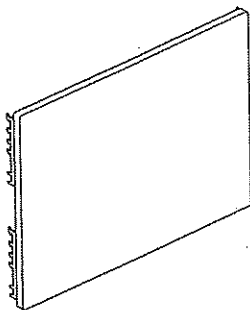

Archworks

Studio

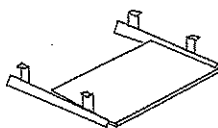

Essentials

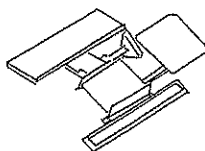
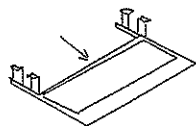

Cu.

Description	Ship Weight in Lbs.	Model Number	Price
TACKBOARDS (PANEL MOUNTED)			
NOTE: When utilizing a 62H panel in conjunction with a Flipper Door cabinet and a 29H worksurface, the largest possible tackboard is a 16H.			
<input type="checkbox"/> Specify finish color for: FABRIC: Type & Color Grade 2 upcharge 6% Refer to Order Guide			
24W x 1D x 12H	6	TPTKB2412	\$121.00
24W x 1D x 16H	8	TPTKB2416	\$123.00
24W x 1D x 30H	14	TPTKB2430	\$158.00
24W x 1D x 48H	23	TPTKB2448	\$173.00
30W x 1D x 12H	7	TPTKB3012	\$123.00
30W x 1D x 16H	10	TPTKB3016	\$128.00
30W x 1D x 30H	18	TPTKB3030	\$163.00
30W x 1D x 48H	29	TPTKB3048	\$184.00
36W x 1D x 12H	9	TPTKB3612	\$125.00
36W x 1D x 16H	12	TPTKB3616	\$132.00
36W x 1D x 30H	23	TPTKB3630	\$171.00
36W x 1D x 48H	35	TPTKB3648	\$195.00
42W x 1D x 12H	10	TPTKB4212	\$128.00
42W x 1D x 16H	13	TPTKB4216	\$137.00
42W x 1D x 30H	25	TPTKB4230	\$179.00
42W x 1D x 48H	40	TPTKB4248	\$205.00
48W x 1D x 12H	14	TPTKB4812	\$134.00
48W x 1D x 16H	15	TPTKB4816	\$139.00
48W x 1D x 30H	30	TPTKB4830	\$184.00
48W x 1D x 48H	46	TPTKB4848	\$216.00

COMPUTER KEYBOARD PRODUCTS

Slide-out keyboard drawer (specify laminate color)
28W x 10D x 1H 5 AC-KB1028 \$149.00

Slide-out keyboard tray (molded black plastic)
21W x 10D x 1H 5 AC-KB1021 \$119.00

Articulating keyboard drawer w/ GEL wrist rest (black only)
28W x 10D x 1H 10 AC-KB1028ARTM \$298.00

MISCELLANEOUS HARDWARE

While all Panel furniture is shipped with the necessary mounting hardware for a typical installation there are situations that require specialized or additional hardware. All hardware shown below comes with the necessary screws included.



Description	Ship Weight In Lbs.	Model Number	Price
WALL TRACK For attachment of worksurfaces and overhead components to structural walls. Wall track is painted black. NOTE: Sold individually, not in pairs. Dimensions: 3/4"D x 3/4"W x 60"H. Available in Black Only.	4	TPTRACK	\$53.00

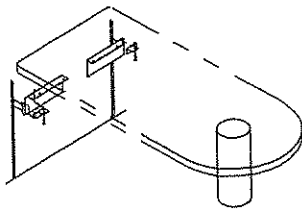

CONFERENCE RUNOFF BRACKET To connect a conference runoff directly to a panel run. Dimensions: 30" Long x 6" High; for 30" - 36" Runs. <input type="checkbox"/> Specify finish color for: Black Only	10	TPB9669	\$107.00
30W & 36W			

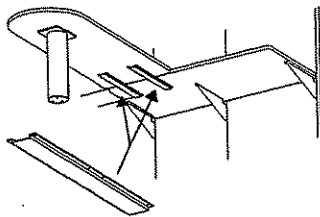

CONFERENCE RUNOFF HAT CHANNELS Provide attachment for conference worksurfaces which are mounted perpendicular to the front edge of a worksurface. Set of (2) channels 22" long by 4 1/2" wide, furnished in black.	6	TPB9646	\$56.00
--	---	---------	---------

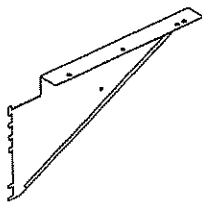

RIGHT HAND CANTILEVER BRACKETS To support worksurfaces from a panel run. Dimensions: J729 - 16" Deep; J730 - 20" Deep <input type="checkbox"/> Specify finish color for: BLACK Only	7	TPB729	\$21.00
For 18D/20D/24D Worksurfaces	8	TPB730	\$47.00
For 30D Worksurface			

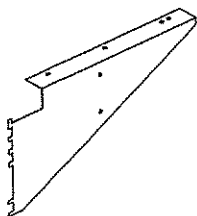

LEFT HAND CANTILEVER BRACKETS To support worksurfaces from a panel run. Dimensions: J731 - 16" Deep; J732 - 20" Deep <input type="checkbox"/> Specify finish color for: BLACK ONLY	7	TPB731	\$21.00
For 18D/20D/24D Worksurfaces	8	TPB732	\$47.00
For 30D Worksurface			

Premier

Archworks

Studio

Essentials

Arves

MISCELLANEOUS HARDWARE

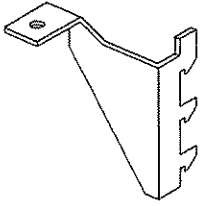

Description	Ship Weight In Lbs.	Model Number	Price
CORNER BRACKET			
Used to support front edge of a worksurface when an adjacent panel is present. Dimensions: 2"D x 3"H.			
<input type="checkbox"/> Specify finish color for: BLACK ONLY			
Right Hand Corner Bracket	3	TPB735	\$13.00
Left Hand Corner Bracket	3	TPB736	\$13.00

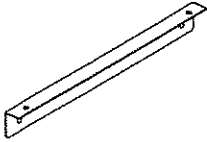

L-BRACKET			
Used to connect top of support panel and worksurface. Requires locking bracket. Dimensions: 9 1/2" Long			
<input type="checkbox"/> Specify finish color for: BLACK ONLY			
	3	TPB737	\$14.00



RIGHT HAND SUPPORT PANEL BRACKET			
Used to connect body of support panel to stanchion. Requires locking bracket. Dimensions: 8 1/2" High			
<input type="checkbox"/> Specify finish color for: BLACK ONLY			
	3	TPB738	\$14.00



LEFT HAND SUPPORT PANEL BRACKET			
Used to connect body of support panel to stanchion. Requires locking bracket. Dimensions: 8 1/2" High			
<input type="checkbox"/> Specify finish color for: BLACK ONLY			
	3	TPB739	\$14.00

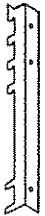

RIGHT HAND BRACKET FOR EDGEBANDED OVERHEADS			
Used to connect body of support panel to stanchion. Requires locking bracket. Dimensions: 15 3/8" High			
<input type="checkbox"/> Specify finish color for: BLACK ONLY			
	3	TPB743	\$28.00



LEFT HAND BRACKET FOR EDGEBANDED OVERHEADS			
Used to connect body of support panel to stanchion. Requires locking bracket. Dimensions: 15 3/8" High			
<input type="checkbox"/> Specify finish color for: BLACK ONLY			
	3	TPB744	\$28.00

Premier

Archworks

Studio

Essentials

Cl

MISCELLANEOUS HARDWARE



RIGHT HAND BRACKET TACKBOARDS

Used to connect body of support panel to stanchion. Requires locking bracket.
 Dimensions: 8 1/2" High

- Specify finish color for:
BLACK ONLY

3	TPB745	\$28.00
---	--------	---------

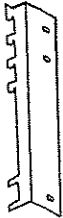

LEFT HAND BRACKET FOR TACKBOARDS

Used to connect body of support panel to stanchion. Requires locking bracket.
 Dimensions: 8 1/2" High

- Specify finish color for:
BLACK ONLY

3	TPB746	\$28.00
---	--------	---------

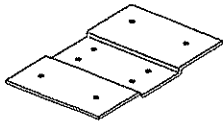

COUNTER TOP BRACKET

Used to connect a counter top to a panel run.
 Dimensions: 3 3/4"W x 5 1/2" Long

- Color: Black

4	TPB742	\$24.00
---	--------	---------

Premier

Archworks

Studio

Essentials

Arves

Premier Series
by
Workstream

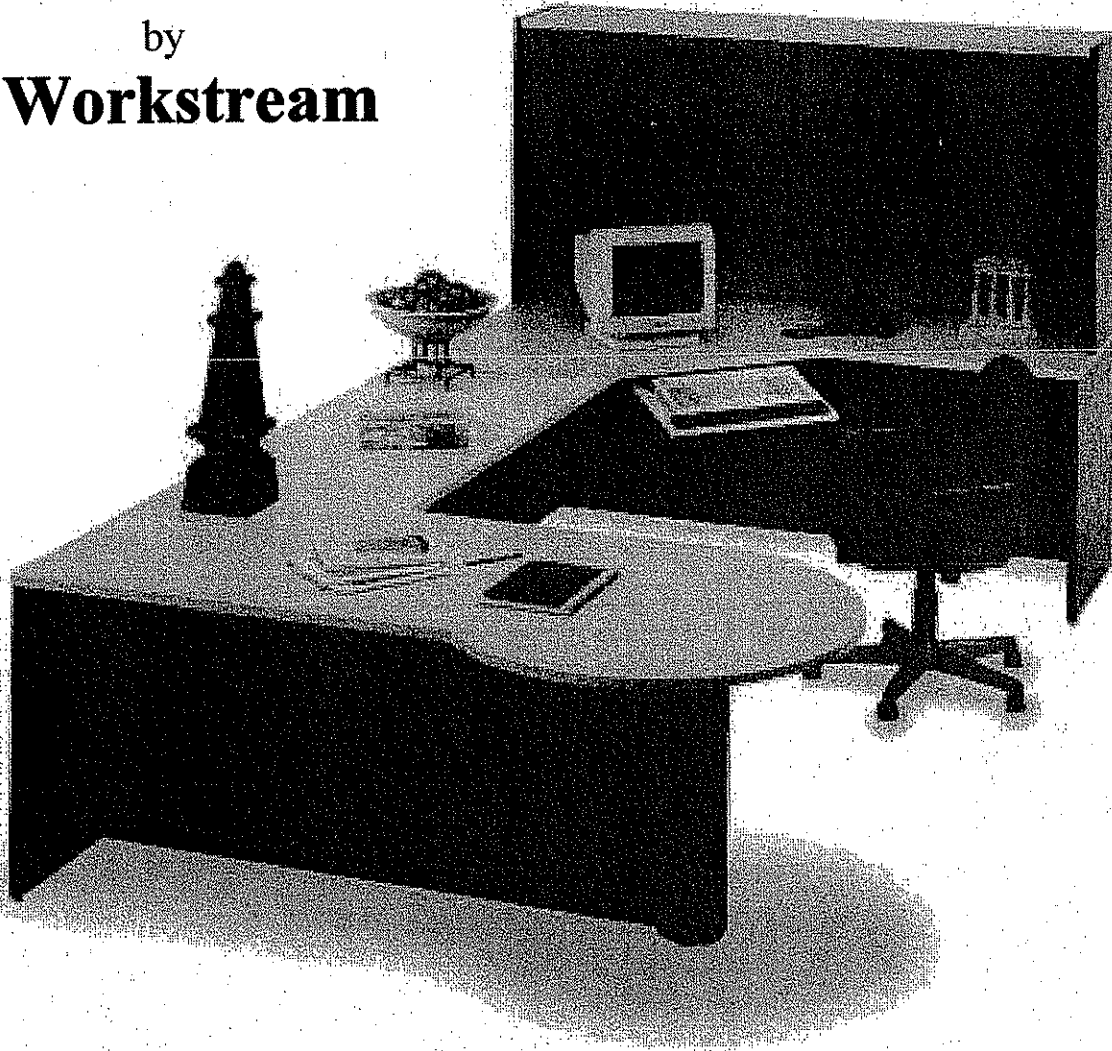

COMMERCIAL & GSA PRICE LIST

Effective July 1, 2006

Desking System

**General Services Administration - Federal Supply Services
Authorized Federal Supply Schedule**

**Contract Period: October 1, 2001 through September 30, 2006. Hamilton
Sorter, Inc. / Fairfield, OH 45014 / Business Size: Small Business Toll
Free: 800-503-9966 / Fax: 800-503-9968**

The Premier Series

Table of Contents

Terms & Conditions ...	3-4
Understanding the Model Number...	5
Fixed-Height Workstations ...	6
Corner Workstations...	7
Freestanding Returns ...	8
Conference Table Returns ...	9
Bridges ...	10
Freestanding Overhead Storage Units ...	11
Undertable Accessories ...	12
Storage Units ...	13 - 14
Cable Management ...	15
Tackboard, Forms Storage and Tasklights...	16
Vertical Storage Cabinets...	17
Bookcases...	18
Conference Tables ...	19
Special Edging ...	20
Finishes and Laminates ...	21

The Premier Series

Commercial Terms & Conditions

TERMS OF SALE: Orders, sales, and contracts are expressly conditioned on acceptance of our terms, which constitute the complete and exclusive contract between the parties. We object to any additional or different terms proposed by the Buyer. Our failure to specifically object to additional or different terms shall not be deemed a waiver of exclusivity of our terms.

No order or contract shall be effective or binding upon us unless accepted by Hamilton Sorter in Fairfield, Ohio. Sales representatives, dealers or agents are not authorized to bind us to any terms additional to or different than the terms and conditions contained herein. Representations made by agents are not part of this contract and do not constitute a warranty unless specifically included herein. This agreement may not be modified except by written agreement signed by an executive officer of Hamilton Sorter. **PRICES:** Prices are F.O.B. in Fairfield, Ohio. Prices include all packing and cartoning charges. Shipping, handling, storage, installation, taxes (where applicable) and other charges will be added to advertised or quoted prices. Prices, dimensions and specifications shown are subject to change without notice. **ORDERING:** Production and/or shipping will not be scheduled until receipt of Buyer's written purchase order. Incomplete orders will not be scheduled for production. Order Acknowledgements are processed when the order is scheduled for production. All literature including, but not limited to, specifications, drawings, weights and dimensions, catalogs, price lists and advertising material is for illustrative purposes only and shall not be construed as a warranty. The Buyer assumes responsibility for suitability of our products in their final environment.

TERMS OF PAYMENT:

NET 30 DAYS. Until credit is established, the Company may require a cash deposit when an order is placed for up to the entire amount of the order.

MINIMUM ORDER:
\$250.00 List

ORDERING ADDRESS:
Hamilton Sorter
3158 Production Drive
Fairfield, Ohio 45014

PAYMENT ADDRESS:
Hamilton Sorter
2504 Pay Sphere Circle
Chicago, IL 60674-2504

SHIPPING: Delivery shall be F.O.B. our factory, Fairfield, Ohio. We are authorized, but not required, to arrange shipping by common carrier. Unless specifically instructed, we arrange shipping, and choose the route and carrier. Most shipments are made by motor freight or parcel service. Lead times quoted or estimated for shipping are estimated and we are not responsible for any losses resulting from delays. An additional 3% net discount will be provided for all blanket wrapped orders. **DAMAGE IN TRANSIT:** Our obligations are to be deemed fulfilled, delivery complete, and the risk of loss shifted to the Buyer as soon as conforming goods are delivered to a common carrier. All products are thoroughly inspected and carefully packaged prior to shipment. The Buyer is

responsible for inspecting all cartons immediately on arrival and notifying the common carrier of any damage (whether visible or concealed) within fifteen (15) days after receipt of merchandise. The Buyer assumes responsibility for any claims against the carrier. All cartoning must be kept with damaged materials.

SELLER'S NON PERFORMANCE: We shall not be held responsible for any loss, delay, failure to deliver or damage caused by our inability to obtain labor, materials, fuel or supplies; fire, accidents, floods or adverse weather conditions; strikes, lockouts or other labor disputes; embargoes, governmental acts or requirements; wars, insurrections or riots, or by any other cause beyond reasonable control of ourselves or our suppliers.

LIMITED WARRANTY: Most Hamilton Sorter products are warranted to be free from defects for ten (10) years from the time you receive the shipment. This warranty period is to repair or provide a replacement part at Hamilton Sorter's option. Some products are warranted for three (3) years. They are: fabric, task lights, power strips, casters, adjustable keyboards and aluminum frame powder-coating.

The warranty does not apply if:

- Damage occurs after the product has been received with no damage noted.
- Damage results from the user's misuse of the product.
- The product is modified after shipment.
- Other manufacture's products are attached to or intermembered with our products.
- Unauthorized people have moved, installed, modified or repaired the product.
- The product was a nonstandard item built to customer specifications.

For items to be replaced under warranty, please fax us a Warranty Request. It is important that you provide the original sales order number and model number so we can determine how the original product was made. We may replace the entire product instead of a damaged part.

EXCEPT AS STATED ABOVE, HAMILTON SORTER MAKES NO EXPRESS OR IMPLIED WARRANTIES AS TO ANY PRODUCT IN PARTICULAR, MAKES NO WARRANTY OF MERCHANTABILITY OR WARRANTY OF FITNESS FOR ANY PARTICULAR PURPOSE. OUR SOLE AND EXCLUSIVE OBLIGATION UNDER THIS WARRANTY IS TO REPAIR OR REPLACE DEFECTIVE PRODUCTS AT OUR OPTION. WORKSTREAM SHALL NOT BE LIABLE FOR INCIDENTAL OR CONSEQUENTIAL DAMAGES FOR LOST PROFIT OR SALES, OR DAMAGES FOR LOST PROFIT OR SALES, OR DAMAGES FOR INJURIES TO PERSON OR PROPERTY.

CHANGES/CANCELLATIONS: Orders may not be changed or canceled without written consent. Orders for non-standard or modified products may not be canceled. Cancellation or change request must be submitted within three (3) working days after receipt of the Order Acknowledgement, providing the order has not already been put into production. A minimum charge of 25% will be imposed for changes or cancellation. The minimum charge will be increased if necessary to fully compensate us for all materials ordered, work performed, lost profits, reasonable overhead, and any other expenses resulting from the cancellation or change.

GOVERNING LAWS: The agreement shall be governed by the laws of the State of Ohio.

ALL PRICES AND PRODUCT SPECIFICATIONS ARE SUBJECT TO CHANGE WITHOUT NOTICE.

GSA TERMS AND CONDITIONS

1. TABLE OF AWARDED SPECIAL ITEMS NUMBERS

Special Item No.
711-2 Worksurfaces, Workstations, Computer Furniture, Accessories
711-3 Filing and Storage Cabinets
711-11 Conference Tables
711-94 Design/Layout Services (\$50 per hour) *jc*
711-92 Installation Services (negotiated each contract)

2. MAXIMUM ORDER LIMITATION (MOL)

Maximum dollar value order is \$500,000 net product cost

3. MINIMUM ORDER

Minimum dollar value order to be issued under this contract is \$100 list

4. GEOGRAPHIC COVERAGE (Delivery Area)

Geographic coverage of this contract is the 48 contiguous states and the District of Columbia

5. POINT OF PRODUCTION

Fairfield (Butler County), Ohio

6. DISCOUNTS FROM LIST PRICE

All contract items are net of minimum applicable discounts

7. QUANTITY DISCOUNTS

Order Size	Discount
At List Price	
\$0-\$60,000	
\$60,001-\$500,000	40% <i>jc</i>

8. PROMPT PAYMENT TERMS

1% 20 days, Net 30 days from date of invoice for all items.

9a. GOVERNMENT COMMERCIAL CREDIT CARD WILL BE ACCEPTED

9b. DISCOUNT FOR PAYMENT BY GOVERNMENT COMMERCIAL CREDIT CARD

No additional discount.

10. FOREIGN ITEMS

No foreign product items are included.

11. TIME OF DELIVERY

Within 90 days ARO.

12. FOB POINT

Prices listed in this contract are FOB destination. Shipments outside the geographical coverage are FOB port of embarkation continental U.S. Inside delivery is included in destination freight charges if requested at time order is placed. Installation is not included in destination freight charges.

13. ORDERING ADDRESS

Hamilton Sorter
c/o Participating Dealer
3158 Production Drive
Fairfield, OH 45014
Telephone: 513-870-4400
Fax: 513-870-4401

14. PAYMENT ADDRESS

Hamilton Sorter
2504 Pay Sphere Circle
Chicago, IL 60674-2504

15. LIMITED LIABILITY

Hamilton Sorter (Workstream) products except those products or parts noted below, are warranted to be free from defects in design, materials and workmanship for a period of ten (10) years from the date of acceptance. During the warranty period, all defective product will be repaired or replaced at Hamilton Sorter's expense, including parts, labor and transportation. The following products and parts are warranted for three (3) years from the date of acceptance: tackboard fabric, tasklights, multiple outlet power strips (MOPS), casters and adjustable keyboards. The warranty is not applicable if any of the following conditions exist:

- damage occurs after the product has been received free and clear with no exceptions noted.
- damage results from accident, negligence, misuse or fault of a customer/user.
- products are built to customer specifications (specials)
- product is modified after acceptance.
- attachments are made of/to other manufacturer's products
- installation was not performed or approved by an authorized Hamilton Sorter dealer.
- persons not approved or authorized by Hamilton Sorter have moved, installed, modified, altered, replaced or repaired the product.

Except as stated above, Hamilton Sorter makes no express or implied warranties as to any product, in particular, makes no warranty of merchantability or warranty of fitness for any particular purpose. Our sole and exclusive obligation under this warranty is to repair or replace defective products or, at our option, to pay the reasonable cost of repair or replacement or issue credit. Hamilton Sorter shall not be liable for incidental or consequential damages, for lost profits or sales, or damages for injuries to person or property.

16. CHANGES/CANCELLATIONS/RETURNS

Orders may not be changed or canceled without written consent. Orders for non-standard or modified products may not be canceled. Cancellation or change requests must be submitted within three (3) working days after receipt of the Order Acknowledgment, providing the order has not already been put into production. A minimum charge of 20% will be imposed for changes or cancellation. The minimum charge will be increased if necessary to fully compensate us for all materials ordered, work performed, lost profits, reasonable overhead, and any other expenses resulting from cancellation or change.

Merchandise is not returnable unless written authorization is received from the factory. All transportation charges must be prepaid. Collect shipments will not be accepted. Return shipments, when accepted, are subject to a minimum 20% rehandling, restocking charge of the net invoice amount. Any open market items ordered in conjunction with the contract items will be subject to a 100% restocking fee. Our agreement to accept a return is conditional upon our inspection of the returned product.

17. EXPORT PACKING CHARGES

Not applicable

18. TERMS & CONDITIONS OF RENTAL, MAINTENANCE AND REPAIR

Not Applicable

19. TERMS AND CONDITIONS OF INSTALLATION

Negotiated on a project-by-project basis.

20. TERMS AND CONDITIONS OF REPAIR PARTS

Not Applicable

21. LIST OF SERVICE AND DISTRIBUTION POINTS

Not Applicable

22. LIST OF PARTICIPATING DEALERS

List available upon request

23. PREVENTATIVE MAINTENANCE

Not Applicable

The Premier Series

Understanding the Model Number

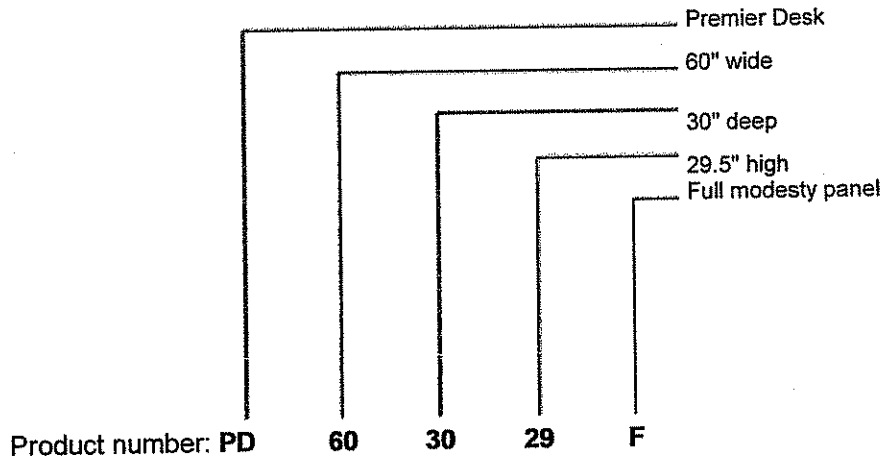

MODIFICATIONS

Include dimensional changes in the model number. For example, PD603029F modified to 27"D would change to a PD602729F. For modification of the modesty panel and dimensional changes are fractions of an inch, please call you Customer Focus Team.

Workstations, Returns, Bridges, Conference Return

\$120 to reduce one dimension

\$180 to reduce two dimensions

\$240 to reduce three dimensions

\$120 to reposition modesty panel

Overhead Storage Units

\$120 to reduce one dimension

\$180 to reduce two dimensions

Vertical Storage Closets (excluding one with lateral files)

\$120 to reduce one dimension

\$180 to reduce two dimensions

\$240 to reduce three dimensions

Bookcases

\$120 to reduce one dimension

\$180 to reduce two dimensions

\$240 to reduce three dimensions

HANDLE OPTIONS:



Elliptical



Crescent/black



Crescent/chrome

The Premier Series

Fixed-Height Workstations

1. The modesty panel is located 10 1/2" from the rear on 30"D and 36"D units; and 1" from the rear on 24"D units.
2. You may modify a 29 1/2"H workstation to a 26 1/2"H workstation by changing the "29" to a "26" in the model number. This can be done at no charge.
3. Workstations 36" and wider receive two 3 1/4" grommets. Workstations less than 36"W receive one grommet.

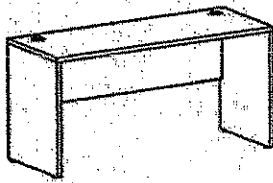

PD602429

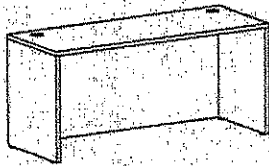

PD663029F

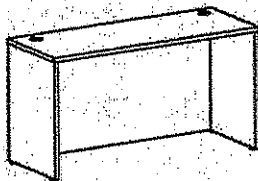

PD603629F

Model Number	Width	Depth	Height	Weight	Price	w/ full modesty add "F" to model #	
						Weight	Price
24"D							
PD242429	24	24	29 1/2	66	\$389	86	\$495
PD302429	30	24	29 1/2	74	\$416	94	\$509
PD362429	36	24	29 1/2	82	\$443	102	\$549
PD422429	42	24	29 1/2	90	\$490	110	\$577
PD482429	48	24	29 1/2	97	\$495	117	\$590
PD542429	54	24	29 1/2	105	\$521	125	\$627
PD602429	60	24	29 1/2	113	\$548	133	\$655
PD662429	66	24	29 1/2	121	\$576	141	\$682
PD722429	72	24	29 1/2	129	\$602	149	\$710
30"D							
PD243029	24	30	29 1/2	78	\$421	98	\$529
PD303029	30	30	29 1/2	86	\$450	106	\$559
PD363029	36	30	29 1/2	95	\$480	115	\$584
PD423029	42	30	29 1/2	104	\$507	124	\$615
PD483029	48	30	29 1/2	113	\$536	133	\$642
PD543029	54	30	29 1/2	122	\$564	142	\$672
PD603029	60	30	29 1/2	131	\$594	151	\$701
PD663029	66	30	29 1/2	140	\$622	160	\$730
PD723029	72	30	29 1/2	149	\$652	169	\$759
36"D							
PD243629	24	36	29 1/2	78	\$442	98	\$548
PD303629	30	36	29 1/2	86	\$472	106	\$579
PD363629	36	36	29 1/2	95	\$503	115	\$609
PD423629	42	36	29 1/2	104	\$532	124	\$666
PD483629	48	36	29 1/2	113	\$563	133	\$697
PD543629	54	36	29 1/2	122	\$592	142	\$728
PD603629	60	36	29 1/2	131	\$623	151	\$760
PD663629	66	36	29 1/2	140	\$653	160	\$791
PD723629	72	36	29 1/2	149	\$683	169	\$822

The Premier Series

Corner Workstations

1. A 42" dimension allows for either a 24"D return or a 30"D return. This is determined by the last two digits of the model number. For example, a PD424230FHC would use 30"D returns.
2. The standard keyboard area for corner units are as follows: PD363624FHC - 16.971"; PD424224FHC - 25.508"; PD424230FHC - 17.023"; and PD484830FHC - 25.456".
3. You may modify a 29 1/2"H workstation to a 26 1/2"H workstation by changing the "29" to "26" in the model number. This may be done at no charge.
4. A 29 1/2"H corner unit can be joined to a 26 1/2"H corner return. A drop bracket will be provided determined by the location of the unit on your floor plan.
5. Workstations have one grommet centered at the rear of the worksurface and centered in the modesty panel. Units with half legs have a grommet in each leg.

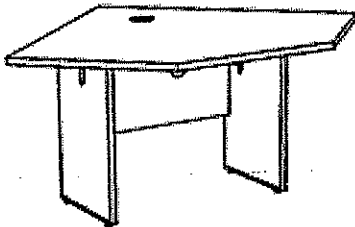

PD424224FHC

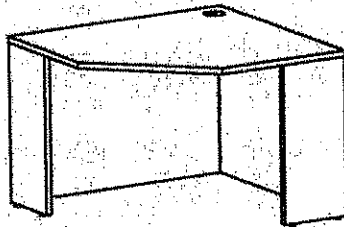

PD484830FHC

Model Number	Width	Depth	Height	Return Depth	Weight	Price	w/ full modesty & 1/2 legs add 'F' to model #	
							Weight	Price
FIXED HEIGHT								
PD363624FHC	36	36	29 1/2	24	113	\$589	128	\$674
PD424224FHC	42	42	29 1/2	24	145	\$734	150	\$847
PD424230FHC	42	42	29 1/2	30	145	\$734	150	\$847
PD484830FHC	48	48	29 1/2	30	150	\$869	155	\$948

The Premier Series

Freestanding Returns

1. Rectangular returns attach directly to a base unit with a mending plate (included with return). The position of the return in relation to the base unit must be specified by adding "L" or "R" to the end of the return model number.
2. Left returns have a full left leg and a half right leg; right returns have full right leg and a half left leg.
3. A base unit 29 1/2"H can be joined to a return 26 1/2"H. A drop bracket will be provided determined by the location of the unit in your floor plan.
4. The modesty panel is located 10 1/2" from the rear on 30"D units; and 1" from the rear on 24"D units.
5. You may modify a 29 1/2"H return to a 26 1/2"H return by changing the "29" to "26" in the model number. This may be done at no charge.
6. Returns 36" and wider receive two 3 1/4" grommets. Returns less than 36" W receive one grommet.

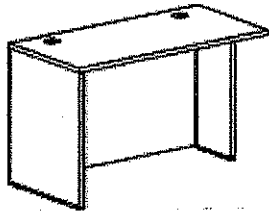

PR422429LF

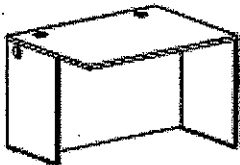

PR362429RF

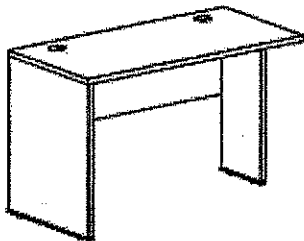

PR423029L

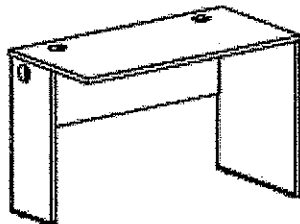

PR483029R

Model Number	Depth	Width	Height	Weight	Price	w/ full modesty add 'F' to model #	
						Weight	Price
24"D LEFT RETURN							
PR242429L	24	24	29 1/2	60	\$356	80	\$463
PR302429L	24	30	29 1/2	67	\$381	87	\$489
PR362429L	24	36	29 1/2	74	\$409	94	\$494
PR422429L	24	42	29 1/2	81	\$435	101	\$544
PR482429L	24	48	29 1/2	88	\$462	108	\$568
PR542429L	24	54	29 1/2	95	\$488	115	\$595
PR602429L	24	60	29 1/2	102	\$515	122	\$622
PR662429L	24	66	29 1/2	107	\$543	127	\$648
PR722429L	24	72	29 1/2	112	\$568	132	\$676
24"D RIGHT RETURN							
PR242429R	24	24	29 1/2	60	\$356	80	\$463
PR302429R	24	30	29 1/2	67	\$381	87	\$489
PR362429R	24	36	29 1/2	74	\$409	94	\$494
PR422429R	24	42	29 1/2	81	\$435	101	\$544
PR482429R	24	48	29 1/2	88	\$462	108	\$568
PR542429R	24	54	29 1/2	95	\$488	115	\$595
PR602429R	24	60	29 1/2	102	\$515	122	\$622
PR662429R	24	66	29 1/2	107	\$543	127	\$648
PR722429R	24	72	29 1/2	112	\$568	132	\$676
30"D LEFT RETURN							
PR243029L	30	24	29 1/2	69	\$386	89	\$492
PR303029L	30	30	29 1/2	77	\$406	97	\$513
PR363029L	30	36	29 1/2	85	\$434	105	\$542
PR423029L	30	42	29 1/2	93	\$462	113	\$568
PR483029L	30	48	29 1/2	101	\$490	121	\$597
PR543029L	30	54	29 1/2	109	\$519	129	\$625
PR603029L	30	60	29 1/2	117	\$548	137	\$655
PR663029L	30	66	29 1/2	125	\$577	145	\$683
PR723029L	30	72	29 1/2	133	\$605	153	\$713
30"D RIGHT RETURN							
PR243029R	30	24	29 1/2	69	\$386	89	\$492
PR303029R	30	30	29 1/2	77	\$406	97	\$513
PR363029R	30	36	29 1/2	85	\$434	105	\$542
PR423029R	30	42	29 1/2	93	\$462	113	\$568
PR483029R	30	48	29 1/2	101	\$490	121	\$597
PR543029R	30	54	29 1/2	109	\$519	129	\$625
PR603029R	30	60	29 1/2	117	\$548	137	\$655
PR663029R	30	66	29 1/2	125	\$577	145	\$683
PR723029R	30	72	29 1/2	133	\$605	153	\$713

The Premier Series

Conference Table Returns

1. The modesty panel on a Conference Table Return is centered.
2. Pedestals, lateral files, keyboards and pencil drawers cannot be placed under Conference Table Returns.

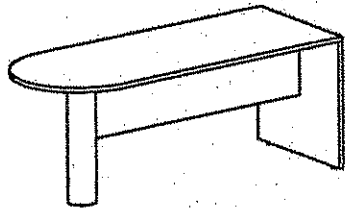

PCT662429D

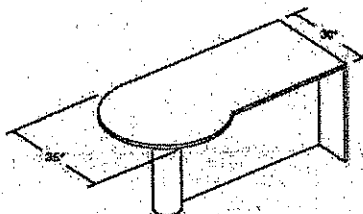

PCT663029PLF

Model Number	Width	Depth	Height	Weight	Price	w/ full modesty add 'F' to model #	
						Weight	Price
'D' TABLES							
PCT602429D	60	24	29 1/2	113	\$827	123	\$934
PCT603029D	60	30	29 1/2	131	\$853	141	\$950
PCT662429D	66	24	29 1/2	131	\$878	141	\$988
PCT663029D	66	30	29 1/2	140	\$904	150	\$1,025
PCT722429D	72	24	29 1/2	140	\$929	150	\$1,064
PCT723029D	72	30	29 1/2	149	\$954	159	\$1,100

'P' TABLES							
PCT663029PL	66	30	29 1/2	150	\$900	160	\$1,007
PCT723029PL	72	30	29 1/2	159	\$915	169	\$1,023
PCT663029PR	66	30	29 1/2	150	\$900	160	\$1,007
PCT723029PR	72	30	29 1/2	159	\$915	169	\$1,023

Bridges

1. Bridges connect two rectangular workstations. They are provided with a double half-leg design.
2. The modesty panel is located 10 1/2" from the rear on 30" D units; and 1" from the rear on 24"D units.
3. A base unit 29 1/2"H can be joined to a bridge 26 1/2"H. A drop bracket will be provided determined by the location of the unit in your floor plan.
4. Bridges 36" and wider receive two 3 1/4" grommet. Bridges less than 36" W receive one grommet.

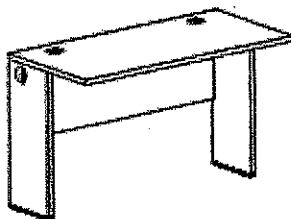

PB482429

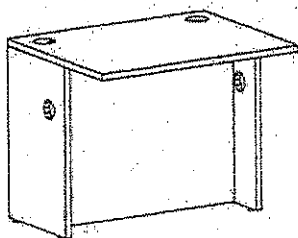

PB483029F

Model Number	Depth	Width	Height	Weight	Price	w/ full modesty add 'F' to model #	
						Weight	Price
24"D							
PB242429	24	24	29 1/2	65	\$335	85	\$444
PB302429	24	30	29 1/2	71	\$373	91	\$468
PB362429	24	36	29 1/2	77	\$389	97	\$495
PB422429	24	42	29 1/2	84	\$416	104	\$523
PB482429	24	48	29 1/2	90	\$429	110	\$535
PB542429	24	54	29 1/2	97	\$468	117	\$576
PB602429	24	60	29 1/2	103	\$494	123	\$602
PB662429	24	66	29 1/2	110	\$522	130	\$626
PB722429	24	72	29 1/2	116	\$548	136	\$655

30"D							
PB243029	30	24	29 1/2	69	\$365	89	\$480
PB303029	30	30	29 1/2	75	\$392	95	\$507
PB363029	30	36	29 1/2	81	\$418	101	\$532
PB423029	30	42	29 1/2	85	\$446	105	\$551
PB483029	30	48	29 1/2	89	\$474	109	\$581
PB543029	30	54	29 1/2	93	\$503	113	\$609
PB603029	30	60	29 1/2	97	\$532	117	\$639
PB663029	30	66	29 1/2	101	\$561	121	\$667
PB723029	30	72	29 1/2	105	\$590	125	\$697

The Premier Series

Freestanding Overhead Storage Units

1. Clearance between the underside of the workstation surface and bottom shelf is 17 $\frac{3}{4}$ ". Clearance between the shelves is 12" with retractable doors, 14" without doors. Usable depth of bottom shelf for units with doors is 12 $\frac{7}{8}$ ".
2. Overhead storage units less than 42" W have one door. 3. Overhead storage units cannot be retrofitted with retractable doors. 4. Cord covers (OSUCC-BL) are available in black. See page 13.
5. Overhead storage units are drilled every 2 $\frac{1}{2}$ " for wire dividers. The number of wire dividers included for each overhead is based on the overhead width.

Width	# of Dividers
18 - 30"	6
33 - 36"	12
39 - 60"	18
60 - 69"	24
72"	30

6. Overhead storage units are shipped fully assembled.

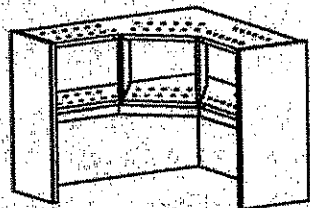

OSU42C

Model Number	Width	Depth	Height	Weight	Price	42"H add .42' to model #.	
						Weight	Price
CORNER UNITS							
OSU36C	36	36	36	150	\$887	170	\$1,222
OSU42C	42	42	36	170	\$950	190	\$1,284
OSU48C	48	48	36	190	\$1,046	210	\$1,404

CORNER UNITS WITH RETRACTABLE DOORS

OSU36C-RD	36	36	36	160	\$1,013		
OSU42C-RD	42	42	36	180	\$1,075		
OSU48C-RD	48	48	36	200	\$1,196		

CORNER UNITS WITH TACKBOARDS

OSU36C-TB	36	36	36	160	\$965	180	\$1,173
OSU42C-TB	42	42	36	180	\$1,024	200	\$1,232
OSU48C-TB	48	48	36	200	\$1,116	220	\$1,325

CORNER UNITS WITH TACKBOARDS AND RETRACTABLE DOORS

OSU36C-TB-RD	36	36	36	170	\$1,091		
OSU42C-TB-RD	42	42	36	190	\$1,150		
OSU48C-TB-RD	48	48	36	210	\$1,265		

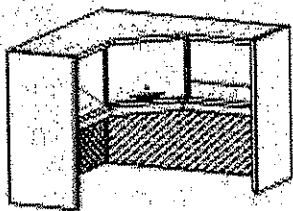

OSU42C-TB-RD

The Premier Series

Freestanding Overhead Storage Units

Model Number	Width	Depth	Height	Weight	Price	42"H add '-42' to model #	
						Weight	Price
CLOSED BACK UNITS							
OSU24CB	24	15	36	80	\$439		
OSU30CB	30	15	36	90	\$456		
OSU36CB	36	15	36	100	\$472		
OSU42CB	42	15	36	110	\$490		
OSU48CB	48	15	36	120	\$507		
OSU54CB	54	15	36	130	\$523		
OSU60CB	60	15	36	140	\$567		
OSU66CB	66	15	36	150	\$585		
OSU72CB	72	15	36	160	\$625		

CLOSED BACK UNITS WITH RETRACTABLE DOORS

OSU24CB-RD	24	15	36	97	\$633	107	\$841
OSU30CB-RD	30	15	36	109	\$653	119	\$861
OSU36CB-RD	36	15	36	120	\$673	130	\$881
OSU42CB-RD	42	15	36	131	\$706	141	\$915
OSU48CB-RD	48	15	36	142	\$733	152	\$941
OSU54CB-RD	54	15	36	154	\$759	164	\$966
OSU60CB-RD	60	15	36	165	\$781	175	\$989
OSU66CB-RD	66	15	36	176	\$807	186	\$1,014
OSU72CB-RD	72	15	36	187	\$866	197	\$1,073

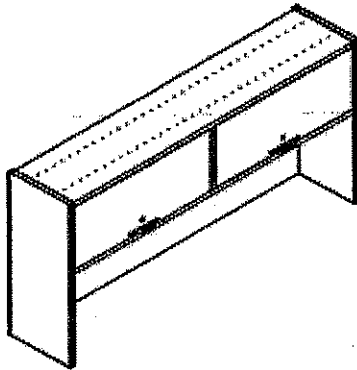

OSU48CB-RD

CLOSED BACK UNITS WITH TACKBOARDS

OSU24TB	24	15	36	86	\$511		
OSU30TB	30	15	36	98	\$524		
OSU36TB	36	15	36	111	\$549		
OSU42TB	42	15	36	123	\$579		
OSU48TB	48	15	36	135	\$610		
OSU54TB	54	15	36	148	\$642		
OSU60TB	60	15	36	160	\$696		
OSU66TB	66	15	36	172	\$724		
OSU72TB	72	15	36	185	\$755		

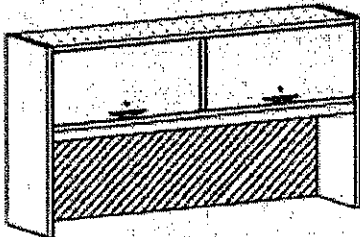

OSU42TB-RD

CLOSED BACK UNITS WITH TACKBOARDS AND RETRACTABLE DOORS

OSU24TB-RD	24	15	36	100	\$789	110	\$996
OSU30TB-RD	30	15	36	115	\$801	125	\$1,009
OSU36TB-RD	36	15	36	130	\$827	140	\$1,036
OSU42TB-RD	42	15	36	145	\$838	155	\$1,043
OSU48TB-RD	48	15	36	160	\$850	170	\$1,057
OSU54TB-RD	54	15	36	175	\$877	185	\$1,085
OSU60TB-RD	60	15	36	190	\$908	200	\$1,116
OSU66TB-RD	66	15	36	205	\$982	215	\$1,190
OSU72TB-RD	72	15	36	220	\$1,058	230	\$1,267

The Premier Series

Undertable Accessories

1. Sliding reference shelves and pencil drawers can be used under 29 1/2" units with 26"H undertable pedestals.

2. Hanging pedestals feature a top pencil drawer and bottom file drawer. 3. All suspension drawers include attachment hardware and are shipped fully assembled. 4. File drawers are made to support hanging folders only.

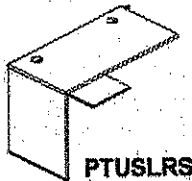

PTUSLRS1612

Model Number	Width	Depth	Height	Weight	Price
SLIDING REFERENCE SHELF					
PTUSLRS1612	16	12	2	10	\$89

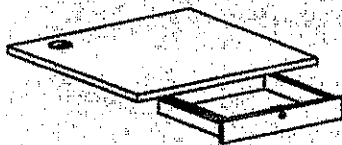

PSDR16-3-20L

PENCIL DRAWER					
PSDR16-3-20	20	17 1/8	3	15	\$162

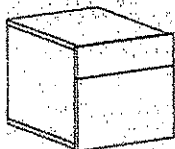

PSML16-S

PENCIL DRAWER W/ LOCK					
PSDR16-3-20L	20	17 1/8	3	15	\$190

TOP PENCIL DRAWER W/ BOTTOM FILE DRAWER					
PSML16-S	15 5/8	17 1/8	16 5/8	70	\$408

TOP PENCIL DRAWER W/BOTTOM FILE DRAWER W/LEFT SIDE LOCK					
PSML16-SLL	15 5/8	17 1/8	16 5/8	70	\$456

TOP PENCIL DRAWER W/BOTTOM FILE DRAWER W/RIGHT SIDE LOCK					
PSML16-SLR	15 5/8	17 1/8	16 5/8	70	\$456

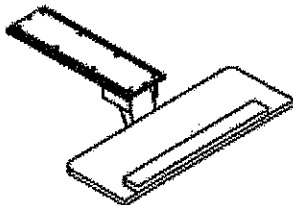

PTUAKD21

ADJUSTABLE KEYBOARD TRAY					
KDADJM	28	11	4	7	\$231
PTUAKD21	21	11	4	15	\$280
PTUAKD28	28	11	4	17	\$317

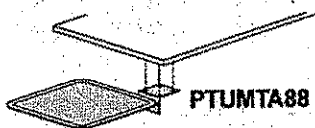

PTUMTA88

MOUSE TRAY ASSEMBLY					
PTUMTA88	8	8	1 1/2	5	\$62

The Premier Series

Storage Units

1. Pedestal drawers are made to support hanging folders only.
2. Locks are anti-tip mechanisms are a standard feature on all 28"H pedestals. Both drawers lock on all twodrawer pedestals and the bottom box drawer and middle file drawer lock together on three-drawer pedestals
3. To place a pedestal under a sliding reference shelf or pencil drawer, use a 26"H pedestal.
4. Multi-use lateral files include a file drawer on the upper left or right, two personal drawers on the opposite side and a bottom lateral file. The location of the file drawer is indicated by "L" or "R" at the end of the model number.
5. Pedestals and lateral files are shipped fully assembled.

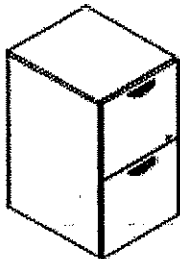

PR-PF1828F

Model Number	Width	Depth	Height	Weight	Price
TWO-DRAWER PEDESTAL					
PR-PF1826F	16 ³ / ₈	18 ¹ / ₂	25 ¹ / ₄	80	\$583
PR-PF1828F	16 ³ / ₈	18 ¹ / ₂	28	80	\$583

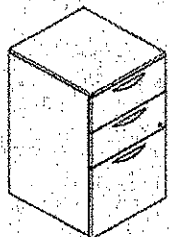

PR-PF1828B

THREE-DRAWER PEDESTAL					
PR-PF1826B	16 ³ / ₈	18 ¹ / ₂	25 ¹ / ₄	85	\$677
PR-PF1828B	16 ³ / ₈	18 ¹ / ₂	28	85	\$677

TWO-DRAWER PEDESTAL W/CASTERS					
PR-PC1828F	16 ³ / ₈	18 ¹ / ₂	25 ¹ / ₄	85	\$636

THREE-DRAWER PEDESTAL W/CASTERS					
PR-PC1828B	16 ³ / ₈	18 ¹ / ₂	25 ¹ / ₄	85	\$731

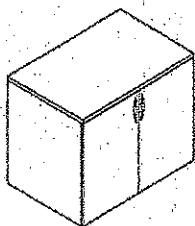

PSP302430FX

TWO-DOOR STORAGE CABINET					
PSP302430FX	30	24	29 ¹ / ₂	150	\$681
PSP362430FX	36	24	29 ¹ / ₂	160	\$734

The Premier Series

Storage Units

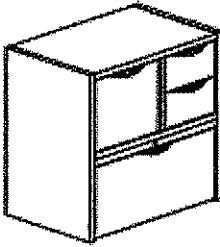

LFMP362028L

Model Number	Width	Depth	Height	Weight	Price
PERSONAL LATERAL FILE W/ LEFT BOX/BOX					
LFMP282028L	28 ^{11/16}	18 ^{1/2}	28	155	\$825
LFMP362028L	36 ^{1/8}	18 ^{5/8}	28	165	\$1,060

PERSONAL LATERAL FILE W/ RIGHT BOX/BOX

LFMP282028R	28 ^{11/16}	18 ^{1/2}	28	155	\$825
LFMP362028R	36 ^{1/8}	18 ^{5/8}	28	165	\$1,060

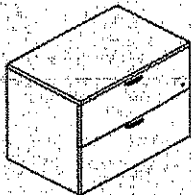

PLF362028

TWO-DRAWER LATERAL FILE

PLF362028	36	18 ^{1/2}	28	175	\$977
PLF362030	36	18 ^{1/2}	29 ^{1/2}	160	\$958

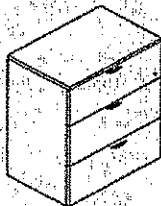

PLF362048

THREE-DRAWER LATERAL FILE

PLF362048	36	18 ^{1/2}	46 ^{1/2}	211	\$1,249
-----------	----	-------------------	-------------------	-----	---------

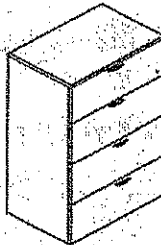

PLF362060

FOUR-DRAWER LATERAL FILE

PLF362060	36	18 ^{1/2}	61 ^{1/2}	261	\$1,575
-----------	----	-------------------	-------------------	-----	---------

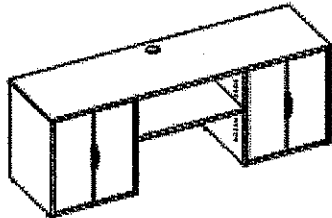

PSP602429CZ

CREDENZA

PSP602429CZ	60	24	29 ^{1/2}	239	\$1,312
PSP662429CZ	66	24	29 ^{1/2}	253	\$1,327
PSP722429CZ	72	24	29 ^{1/2}	267	\$1,356

The Premier Series

Cable Management

1. Cable raceways, available in black only, attach to the inside of the modesty panel.
2. Cable cutouts may be specified on the worksurface, shelves, in the back or leg panels. Specify location in terms of distance from outside edges of the surface. This model number must immediately follow the model number of the item to be modified on the order transmittal form.
3. Any changes to standard grommet locations must be specified on drawing.

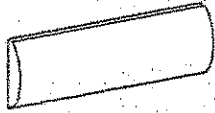

PCMCLR-30



PDCBLC0-3



OSUCC-BL

Model Number	Description	Weight	Price
RACEWAY			
PCMCLR-24	Raceway for 24" table	4	\$17
PCMCLR-30	Raceway for 30" table	4	\$23
PCMCLR-36	Raceway for 36" table	5	\$26
PCMCLR-42	Raceway for 42" table	5	\$29
PCMCLR-48	Raceway for 48" table	5	\$32
PCMCLR-60	Raceway for 60" table	6	\$35
PCMCLR-66	Raceway for 66" table	6	\$42
PCMCLR-72	Raceway for 72" table	6	\$45

GROMMETS			
PDCBLC0-3	Add or reposition grommet		\$15
XPDCBLC0-3	Delete grommet		\$15

CORD COVERS			
OSUCC-BL	18" Black		\$14

The Premier Series

Tackboard, Forms Storage and Tasklights

1. Tackboards can be made any size up to 72"W x 48"H in 1" increments. 2. Fabric color must be specified when ordering tackboard. See Guilford of Maine Collection #2. 3. Forms storage units are shipped fully assembled.

4. Shelf supports in forms storage units are available in black, brown and grey.

5. Tasklights are available in black only.

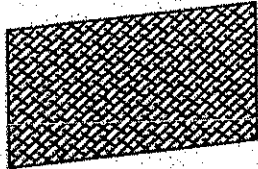

PTBwwhh

Model Number	Width	Depth	Height	Weight	Color	Price
TACKBOARDS						
PTBwwhh	per square foot (specify width & height)					\$20

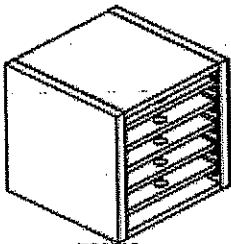

FSM12

FORMS STORAGE INSERT						
FSM12	12 1/2	12	12	20		\$225

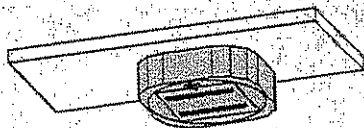

PUSTL-10

TASKLIGHT						
PUSTL-10	10	10			10 Black	\$217



PUSTL-24

PUSTL-24	24	6			10 Black	\$153
PUSTL-24CA	24	6			10 Black	\$173

The Premier Series

Vertical Storage Cabinets

1. Standard depth for all vertical storage cabinets is 24".
2. All vertical storage cabinets include a lock, a removable coat rod and three adjustable shelves; additional shelves may be ordered separately.
3. All cabinets are shipped fully assembled.



PVS3666

Model Number	Width	Depth	Height	Weight	Price
PVS3660	36	24	60	208	\$1,172
PVS3666	36	24	66	220	\$1,226
PVS3672	36	24	72	234	\$1,282
PVS36S	34	21	shelf	14	\$42

The Premier Series

Bookcases

- Shelves for 12"D bookcases are 11"D (book storage); shelves for 18"D bookcases are 16"D (binder and printout storage).
- Bookcases include the following number of adjustable shelves:

Height	Shelves
30"	1
36 - 42"	2
48 - 60"	3
66 - 72"	4

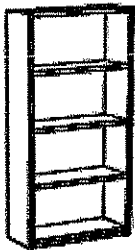

BS361260

Model Number	Depth	Width	Height	Weight	Price
BS301230	30	12	30	70	\$375
BS301236	30	12	36	80	\$417
BS301242	30	12	42	90	\$460
BS301248	30	12	48	100	\$503
BS301254	30	12	54	110	\$546
BS301260	30	12	60	117	\$589
BS301266	30	12	66	127	\$631
BS301272	30	12	72	136	\$674
BS361230	36	12	30	82	\$401
BS361236	36	12	36	93	\$446
BS361242	36	12	42	104	\$489
BS361248	36	12	48	113	\$533
BS361254	36	12	54	124	\$578
BS361260	36	12	60	135	\$622
BS361266	36	12	66	146	\$666
BS361272	36	12	72	156	\$710



BS301872D

Model Number	Height	Weight	Price	w/ doors		w/ locks	
				add 'D' to model # Weight	Price	add 'L' to model # Weight	Price
BS301830	30	70	\$446	106	\$633	111	\$865
BS301836	36	80	\$497	121	\$698	126	\$929
BS301842	42	90	\$549	126	\$763	131	\$994
BS301848	48	100	\$598	141	\$826	146	\$1,057
BS301854	54	110	\$650	146	\$895	151	\$1,126
BS301860	60	117	\$700	158	\$981	163	\$1,212
BS301866	66	127	\$753	172	\$1,044	177	\$1,275
BS301872	72	136	\$804	187	\$1,094	192	\$1,346

BS361830	30	82	\$477	118	\$673	123	\$845
BS361836	36	93	\$529	134	\$739	139	\$907
BS361842	42	104	\$583	140	\$808	145	\$971
BS361848	48	113	\$636	154	\$875	159	\$1,034
BS361854	54	124	\$688	160	\$962	165	\$1,115
BS361860	60	135	\$741	176	\$1,033	181	\$1,182
BS361866	66	146	\$793	191	\$1,102	196	\$1,245
BS361872	72	156	\$847	207	\$1,168	212	\$1,308

The Premier Series

Conference Tables

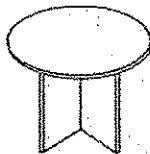

CR42

ROUND

Model Number	Width	Depth	Height	Weight	Price
CR42	42" diameter		29 1/2	110	\$533
CR48	48" diameter		29 1/2	140	\$575



CFT48R

ROUND W/ BLACK METAL BASE

CFT36R	36" diameter		29 1/2	85	\$489
CFT42R	42" diameter		29 1/2	110	\$518
CFT48R	48" diameter		29 1/2	140	\$547

ROUND W/ 1 5/8" TOP AND CYLINDER BASE

CR42BUCL	42" diameter		29 1/2	110	\$1,042
CR48BUCL	48" diameter		29 1/2	140	\$1,071

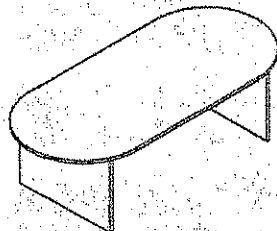

CRR9644

RACETRACK

CRR7236	72	36	29 1/2	127	\$566
CRR9644	96	44	29 1/2	157	\$679
CRR12048	120	48	29 1/2	195	\$907

RACETRACK W/ 1 5/8" TOP

CRR7236BU	72	36	29 1/2	127	\$850
CRR9644BU	96	44	29 1/2	157	\$1,017
CRR12048BU	120	48	29 1/2	195	\$1,360

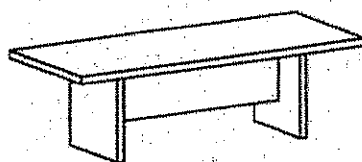

CRC7236

RECTANGULAR

CRC7236	72	36	29 1/2	127	\$443
CRC9644	96	44	29 1/2	157	\$547
CRC12048	120	48	29 1/2	195	\$907

RECTANGULAR W/ 1 5/8" TOP

CRC7236BU	72	36	29 1/2	127	\$621
CRC9644BU	96	44	29 1/2	157	\$749
CRC12048BU	120	48	29 1/2	195	\$927

The Premier Series

Special Edging

1. Postform is available in all laminates. It is available for front and/or rear only. 2. Adding postform to a surface increases its width and/or depth by 1/2" per edge.

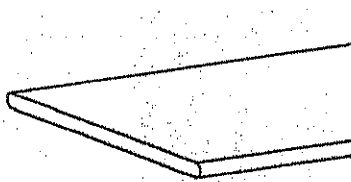

Postform on two edges.

POSTFORM ON ONE EDGE

Model Number	Width	Price
PPFwwdd-1	18 - 24	\$68
PPFwwdd-1	25 - 36	\$82
PPFwwdd-1	37 - 48	\$95
PPFwwdd-1	49 - 60	\$109
PPFwwdd-1	61 - 72	\$120

POSTFORM ON TWO EDGES

PPFwwdd-2	18 - 24	\$128
PPFwwdd-2	25 - 36	\$142
PPFwwdd-2	37 - 48	\$156
PPFwwdd-2	49 - 60	\$168
PPFwwdd-2	61 - 72	\$182

3. T-Molding may be added to worksurfaces with an 8% upcharge.

4. T-Molding may be added to worksurfaces and support legs on Fixed Height Workstations, Corner Workstations, Freestanding Returns and Bridges with 38% upcharge.

The Premier Series

Finishes and Laminates

STANDARD FINISHES

Color Names

Woodgrains

Hard Rock Maple II
Solar Oak
Autumn Cherry
Oiled Cherry
Woodlawn Cherry
African Walnut

Brand Name & Number

Wilsonart 10776-60
Wilsonart 7816-60
Pionite K1727-S
Pionite WC421-S
Casco H1209
Wilsonart 7122T-60

Solids

Fashion Grey
Putty
Slate Grey
Black

Wilsonart D381-60
Formica 85560-58
Wilsonart D91-60
Wilsonart 1595-60

Textured

Crystal Sandstorm
Graphite Nebula

Panval 702
Wilsonart 4623-60

CUSTOM LAMINATES

Wilsonart high-pressure laminate may be chosen for worksurfaces only. Add 20% and allow 4 to 6 weeks for delivery. Specify two mil. HP laminate edge band from the standard 12 colors.

Call the factory for a quote on additional laminates.



FLEX-Y-PLAN

DISTINCTIVE OFFICE FURNITURE

6960 West Ridge Road
P.O. Box CC
Fairview, PA 16415-0829
email: sales@fyp.com

814.474.1565
800.458.0552
Fax 814.474.2129
website: www.fyp.com

September 15, 2006

Department of Administration
Purchasing Division
Building 15
2019 Washington Street, East
Charleston, WV 25305-0130

Re: RFQ Number SYSFURN07.

Flex-Y-Plan submits for the above RFQ.

- A. Flex-Y-Plan's submission includes coverage of the entire state of West Virginia. Access Systems of Charleston will be performing all installations and follow up that is necessary.
- B. 1. Attached are four pages from our price books which are contained on the CD. The four pages indicate product that is excluded from the contract since these specific products do not meet one of the standards in the specifications.
2. Flex-Y-Plan's two (2) different systems furniture product lines (Emphasys and System Four) do not have the fabric attached by a spline. Fabric can be replaced in the field.
- C. On the Affidavit page, under Licensing, Flex-Y-Plan is signing that Access Systems is licensed in West Virginia. Flex-Y-Plan is not licensed in West Virginia and it is not believed that we should be licensed.
- D. Flex-Y-Plan understands that a Certificate of Insurance will be required prior to an award and is willing to submit.
- E. Flex-Y-Plan understands and will comply with the \$ 125.00 registration fee with the Purchasing Department.
- F. Jack Chandler of Access Systems attended the Pre Bid conference.
- G. On the front cover of the CME Case Works price book is a statement that prices are subject to change. For the West Virginia contract, Flex-Y-Plan understands and will comply that the prices in the price book are fixed for the duration of the contract.
- H. In compliance with Section F of the Specifications, the following is submitted:
 1. Flex-Y-Plan has been in the business of manufacturing office furniture and related products since 1964. Flex-Y-Plan has continuously held the Federal GSA contract since the 1970's. In addition to the Federal GSA contract, Flex-Y-Plan holds state contracts in Pennsylvania, New Jersey, New York, Florida and other

states. In addition, Flex-Y-Plan's products are standardized product in for many government and commercial entities.

2. Flex-Y-Plan has an in house staff that can provide drawings and quotations in accordance with the West Virginia contract. Each of the three (3) people are long term employees of Flex-Y-Plan.
3. Access Systems is an experienced furniture installation company. Dave Miller has 15 years of experience with Access Systems and Jack Chandler has 10 years of experience with Access Systems and office furniture.
4. Flex-Y-Plan will be happy to provide references upon request and additional information.



Don R. Worthington
Executive Vice President

Enclosures:

RFQSYSFURN07 with Amendment # 1
5 pages from price books with product that is excluded
Exhibit A -- also included on 2 CD's
Affidavit
Certification
2 CD's with price books, brochures and Excel spreadsheet completed