



State of West Virginia
 Department of Administration
 Purchasing Division
 2019 Washington Street East
 Post Office Box 50130
 Charleston, WV 25305-0130

Request for Quotation

RFQ NUMBER
 PRS07003

PAGE
 1

ADDRESS CORRESPONDENCE TO ATTENTION OF:
 CHUCK BOWMAN
 304-558-2157

*406110534 304-345-1253
 PROGRESSIVE ELECTRIC INC
 PO BOX 3695

CHARLESTON WV 25336

V
E
N
D
O
R

S
H
I
P
T
O

PROTECTIVE SERVICES
 DIVISION OF
 BUILDING 1, ROOM 152-A
 1900 KANAWHA BOULEVARD, EAST
 CHARLESTON, WV
 25305 304-558-9911

DATE PRINTED 10/20/2006	TERMS OF SALE	SHIP VIA	F.O.B.	FREIGHT TERMS
BID OPENING DATE: 11/14/2006		BID OPENING TIME 01:30PM		

LINE	QUANTITY	UOP	CAT. NO.	ITEM NUMBER	UNIT PRICE	AMOUNT
0001	1	EA		906-68	\$65,000.00	\$65,000.00
				Optional Price *See Attached!*	\$60,500.00	\$60,500.00
<p>THE WEST VIRGINIA PURCHASING DIVISION, ON BEHALF OF THE AGENCY, THE WEST VIRGINIA DIVISION OF PROTECTIVE SERVICES, IS SOLICITING BIDS TO SUPPLY AND INSTALL (1) MGE GALLAXY 3000 UNINTERRUPTABLE POWER SOURCE, (OR EQUAL) CONFIGURED WITH A BATTERY SUPPLY CONTAINING A 20KVA FOUR HOUR CONTINUOUS SUPPLY OF BACKUP POWER.</p> <p>A MANDATORY ON-SITE PRE-BID MEETING IS SCHEDULED FOR 11/01/2006 AT 1:30 PM IN BUILDING #1 OF THE CAPITOL COMPLEX ROOM 152A. PLEASE CALL 304.558.9911 FOR SPECIFIC DIRECTIONS TO THE SITE.</p> <p>THE AGENCY REQUIRES A FULL ONE YEAR WARRANTY ON THE SYSTEM BEGINNING FROM THE DATE OF INSTALLATION ACCEPTANCE BY THE AGENCY. WARRANTY START DATE WILL BE ESTABLISHED VIA CHANGE ORDER. FULL ONE YEAR WARRANTY TO INCLUDE ALL PARTS, LABOR, AND COMMUNICATIONS CAPABILTY</p> <p>VENDOR RESPONSE TIME FOR MAINTENANCE OR TROUBLE CALLS SHALL BE BASED ON THE CRITICAL NATURE OF THE PROBLEM, BUT A MAJOR SYSTEM FAILURE RESULTING IN A LOSS OF POWER TO THE COMMAND CENTER REQUIRES A VENDOR CALL BACK RESPONSE WITHIN THIRTY (30) MINUTES OF REPORT OF THE INCIDENT. THE VENDOR IS TO HAVE A CERTIFIED TECHNICIAN ON SITE WITHIN 90 MINUTES OF THE INITIAL REPORT OF THE INCIDENT. THE VENDOR IS TO HAVE THE SYSTEM OPERATION-AL WITHIN 180 MINUTES OF THE REPORT OF THE INCIDENT.</p> <p>VENDORS WISHING TO SUBMIT A UPS TO BE CONSIDERED AS AN</p>						

SEE REVERSE SIDE FOR TERMS AND CONDITIONS

SIGNATURE 	TELEPHONE 304-345-1253	DATE 11-14-06
TITLE PRESIDENT	FEIN 550585404	ADDRESS CHANGES TO BE NOTED ABOVE

WHEN RESPONDING TO RFQ, INSERT NAME AND ADDRESS IN SPACE ABOVE LABELED 'VENDOR'

**GENERAL TERMS & CONDITIONS
REQUEST FOR QUOTATION (RFQ) AND REQUEST FOR PROPOSAL (RFP)**

1. Awards will be made in the best interest of the State of West Virginia.
2. The State may accept or reject in part, or in whole, any bid.
3. All quotations are governed by the *West Virginia Code* and the *Legislative Rules* of the Purchasing Division.
4. Prior to any award, the apparent successful vendor must be properly registered with the Purchasing Division and have paid the required \$125.00 registration fee.
5. All services performed or goods delivered under State Purchase Orders/Contracts are to be continued for the term of the Purchase Order/Contract, contingent upon funds being appropriated by the Legislature or otherwise being made available. In the event funds are not appropriated or otherwise available for these services or goods, this Purchase Order/Contract becomes void and of no effect after June 30.
6. Payment may only be made after the delivery and acceptance of goods or services.
7. Interest may be paid for late payment in accordance with the *West Virginia Code*.
8. Vendor preference will be granted upon written request in accordance with the *West Virginia Code*.
9. The State of West Virginia is exempt from federal and state taxes and will not pay or reimburse such taxes.
10. The Director of Purchasing may cancel any Purchase Order/Contract upon 30 days written notice to the seller.
11. The laws of the State of West Virginia and the *Legislative Rules* of the Purchasing Division shall govern all rights and duties under the Contract, including without limitation the validity of this Purchase Order/Contract.
12. Any reference to automatic renewal is hereby deleted. The Contract may be renewed only upon mutual written agreement of the parties.
13. **BANKRUPTCY:** In the event the vendor/contractor files for bankruptcy protection, this contract is automatically null and void, and is terminated without further order.
14. **HIPAA Business Associate Addendum** - The West Virginia State Government HIPAA Business Associate Addendum (BAA), approved by the Attorney General, and available online at the Purchasing Division's web site (<http://www.state.wv.us/admin/purchase/vrc/hipaa.htm>) is hereby made part of the agreement. Provided that, the Agency meets the definition of a Covered Entity (45 CFR §160.103) and will be disclosing Protected Health Information (45 CFR §160.103) to the vendor.

INSTRUCTIONS TO BIDDERS

1. Use the quotation forms provided by the Purchasing Division.
2. **SPECIFICATIONS:** Items offered must be in compliance with the specifications. Any deviation from the specifications must be clearly indicated by the bidder. Alternates offered by the bidder as **EQUAL** to the specifications must be clearly defined. A bidder offering an alternate should attach complete specifications and literature to the bid. The Purchasing Division may waive minor deviations to specifications.
3. Complete all sections of the quotation form.
4. Unit prices shall prevail in cases of discrepancy.
5. All quotations are considered F.O.B. destination unless alternate shipping terms are clearly identified in the quotation.
6. **BID SUBMISSION:** All quotations must be delivered by the bidder to the office listed below prior to the date and time of the bid opening. Failure of the bidder to deliver the quotations on time will result in bid disqualifications.

SIGNED BID TO:

Department of Administration
Purchasing Division
2019 Washington Street East
Post Office Box 50130
Charleston, WV 25305-0130



State of West Virginia
 Department of Administration
 Purchasing Division
 2019 Washington Street East
 Post Office Box 50130
 Charleston, WV 25305-0130

Request for Quotation

RFQ NUMBER
PRS07003

PAGE
2

ADDRESS CORRESPONDENCE TO ATTENTION OF:
CHUCK BOWMAN 304-558-2157

*406110534 304-345-1253
 PROGRESSIVE ELECTRIC INC
 PO BOX 3695

CHARLESTON WV 25336

VENDOR

SHIP TO

PROTECTIVE SERVICES
 DIVISION OF
 BUILDING 1, ROOM 152-A
 1900 KANAWHA BOULEVARD, EAST
 CHARLESTON, WV
 25305 304-558-9911

DATE PRINTED 10/20/2006	TERMS OF SALE	SHIP VIA	F.O.B.	FREIGHT TERMS
BID OPENING DATE: 11/14/2006		BID OPENING TIME 01:30PM		

LINE	QUANTITY	UOP	CAT NO.	ITEM NUMBER	UNIT PRICE	AMOUNT
<p>EQUAL TO THE UNIT SPECIFIED ARE TO INCLUDE MANUFACTURER DOCUMENTATION, SPECIFICATIONS, BROCHURES, ETC., TO AID THE EVALUATION COMMITTEE IN MAKING THEIR DETERMINATION OF AWARD. THE AGENCY RESERVES THE RIGHT TO REQUEST THIS OR ADDITIONAL INFORMATION FROM ANY VENDOR AT ANY TIME DURING THE EVALUATION PROCESS OF THIS RFQ. FAILURE TO SUPPLY THIS INFORMATION WITHIN THE STATED TIME FRAME MAY RESULT IN THE DISQUALIFICATION OF A VENDOR'S BID.</p> <p>THE MODEL/BRAND/SPECIFICATIONS NAMED HEREIN ESTABLISH THE ACCEPTABLE LEVEL OF QUALITY ONLY AND ARE NOT INTENDED TO REFLECT A PREFERENCE OR FAVOR ANY PARTICULAR BRAND OR VENDOR. VENDORS WHO ARE BIDDING ALTERNATES SHOULD SO STATE AND INCLUDE PERTINENT LITERATURE AND SPECIFICATIONS. FAILURE TO PROVIDE INFORMATION FOR ANY ALTERNATES MAY BE GROUNDS FOR REJECTION OF THE BID. THE STATE RESERVES THE RIGHT TO WAIVE MINOR IRREGULARITIES IN BIDS OR SPECIFICATIONS IN ACCORDANCE WITH SECTION 148-1-4 (F) OF THE WEST VIRGINIA LEGISLATIVE RULES AND REGULATIONS.</p> <p>EXHIBIT 5</p> <p>NOTICE TO PROCEED: THIS CONTRACT IS TO BE PERFORMED WITHIN -60- CALENDAR DAYS AFTER THE NOTICE TO PROCEED IS RECEIVED. UNLESS OTHERWISE SPECIFIED, THE FULLY EXECUTED PURCHASE ORDER WILL BE CONSIDERED NOTICE TO PROCEED.</p> <p>CANCELLATION: THE DIRECTOR OF PURCHASING RESERVES THE RIGHT TO CANCEL THIS CONTRACT IMMEDIATELY UPON WRITTEN NOTICE TO THE VENDOR IF THE MATERIALS OR WORKMANSHIP SUPPLIED ARE OF AN INFERIOR QUALITY OR DO NOT CONFORM WITH THE SPECIFICATIONS OF THE BID AND CONTRACT HERE IN.</p>						

SEE REVERSE SIDE FOR TERMS AND CONDITIONS			
SIGNATURE <i>T. J. By</i>	TELEPHONE 304-345-1253	DATE 11-14-06	
TITLE PRESIDENT	FEIN 550585404	ADDRESS CHANGES TO BE NOTED ABOVE	

WHEN RESPONDING TO RFQ, INSERT NAME AND ADDRESS IN SPACE ABOVE LABELED 'VENDOR'



State of West Virginia
 Department of Administration
 Purchasing Division
 2019 Washington Street East
 Post Office Box 50130
 Charleston, WV 25305-0130

Request for Quotation

RFQ NUMBER
PRS07003

PAGE
3

ADDRESS CORRESPONDENCE TO ATTENTION OF:
CHUCK BOWMAN 304-558-2157

*406110534 304-345-1253
 PROGRESSIVE ELECTRIC INC
 PO BOX 3695

CHARLESTON WV 25336

VENDOR

SHIP TO

PROTECTIVE SERVICES
 DIVISION OF
 BUILDING 1, ROOM 152-A
 1900 KANAWHA BOULEVARD, EAST
 CHARLESTON, WV
 25305 304-558-9911

DATE PRINTED	TERMS OF SALE	SHIP VIA	F.O.B.	FREIGHT TERMS
10/20/2006				
BID OPENING DATE: 11/14/2006		BID OPENING TIME 01:30PM		

LINE	QUANTITY	UOP	CAT NO.	ITEM NUMBER	UNIT PRICE	AMOUNT
<p>WAGE RATES: THE CONTRACTOR OR SUBCONTRACTOR SHALL PAY THE HIGHER OF THE U.S. DEPARTMENT OF LABOR MINIMUM WAGE RATES AS ESTABLISHED FOR KANAWHA COUNTY, PURSUANT TO WEST VIRGINIA CODE 21-5A, ET, SEQ. (PREVAILING WAGE RATES APPLY TO THIS PROJECT)</p> <p>ARBITRATION: ANY REFERENCES MADE TO ARBITRATION OR INTEREST FOR PAYMENTS DUE (EXCEPT FOR ANY INTEREST REQUIRED BY STATE LAW) CONTAINED IN THIS CONTRACT OR IN ANY AMERICAN INSTITUTE OF ARCHITECTS DOCUMENTS PERTAINING TO THIS CONTRACT ARE HEREBY DELETED.</p> <p>WORKERS' COMPENSATION: VENDOR IS REQUIRED TO PROVIDE A CERTIFICATE FROM WORKERS' COMPENSATION IF SUCCESSFUL.</p> <p>ALL OF THE ITEMS CHECKED BELOW WILL BE A REQUIREMENT OF THIS CONTRACT:</p> <p>(XX) INSURANCE: SUCCESSFUL VENDOR SHALL FURNISH PROOF OF COMMERCIAL GENERAL LIABILITY INSURANCE PRIOR TO ISSUANCE OF CONTRACT. UNLESS OTHERWISE SPECIFIED IN THE BID DOCUMENTS, THE MINIMUM AMOUNT OF INSURANCE COVERAGE REQUIRED IS \$250,000.</p> <p>() BUILDERS RISK INSURANCE: SUCCESSFUL VENDOR SHALL FURNISH PROOF OF BUILDERS RISK - ALL RISK INSURANCE IN AN AMOUNT EQUAL TO 100% OF THE AMOUNT OF THE CONTRACT.</p> <p>(XX) BONDS: FIVE PERCENT (5%) OF THE TOTAL AMOUNT OF THE BID PAYABLE TO THE STATE OF WEST VIRGINIA, SHALL BE SUBMITTED WITH EACH BID AS A BID BOND. THE SUCCESSFUL BIDDER SHALL ALSO FURNISH A PERFORMANCE BOND AND LABOR/MATERIAL BOND FOR 100% OF THE AMOUNT OF THE CONTRACT. BONDS MAY BE PROVIDED IN THE FORM OF A CERTIFIED CHECK, IRREVOCABLE LETTER OF CREDIT, OR BOND FURNISHED BY A</p>						

SEE REVERSE SIDE FOR TERMS AND CONDITIONS

SIGNATURE	TELEPHONE	DATE
	(304) 345-1253	11/14/2006

TITLE	FEIN	ADDRESS CHANGES TO BE NOTED ABOVE
President	55-0585404	

WHEN RESPONDING TO RFQ, INSERT NAME AND ADDRESS IN SPACE ABOVE LABELED 'VENDOR'



State of West Virginia
 Department of Administration
 Purchasing Division
 2019 Washington Street East
 Post Office Box 50130
 Charleston, WV 25305-0130

Request for Quotation

RFQ NUMBER
PRS07003

PAGE
4

ADDRESS CORRESPONDENCE TO ATTENTION OF:
CHUCK BOWMAN 304-558-2157

*406110534 304-345-1253
 PROGRESSIVE ELECTRIC INC
 PO BOX 3695

CHARLESTON WV 25336

VENDOR

SHIP TO

PROTECTIVE SERVICES
 DIVISION OF
 BUILDING 1, ROOM 152-A
 1900 KANAWHA BOULEVARD, EAST
 CHARLESTON, WV
 25305 304-558-9911

DATE PRINTED 10/20/2006	TERMS OF SALE	SHIP VIA	F.O.B.	FREIGHT TERMS
BID OPENING DATE: 11/14/2006		BID OPENING TIME 01:30PM		

LINE	QUANTITY	UOP	CAT NO	ITEM NUMBER	UNIT PRICE	AMOUNT
				<p>SOLVENT SURETY COMPANY AUTHORIZED TO DO BUSINESS IN THE STATE OF WEST VIRGINIA. A LETTER OF CREDIT SUBMITTED IN LIEU OF A PERFORMANCE AND LABOR & MATERIAL BOND WILL ONLY BE ALLOWED FOR PROJECTS UNDER \$100,000. PERSONAL OR BUSINESS CHECKS ARE NOT ACCEPTABLE IN LIEU OF THE 5% BID BOND, PERFORMANCE BOND, OR LABOR AND MATERIAL BOND.</p> <p>() MAINTENANCE BOND: A TWO (2) YEAR MAINTENANCE BOND COVERING THE ROOFING SYSTEM WILL BE A REQUIREMENT OF THE SUCCESSFUL VENDOR.</p> <p>REV. 11/00</p> <p>EXHIBIT 7</p> <p>DOMESTIC ALUMINUM, GLASS & STEEL IN PUBLIC WORKS PROJECTS</p> <p>IN ACCORDANCE WITH WEST VIRGINIA CODE 5-19-1 ET., SEQ., EVERY CONTRACT FOR CONSTRUCTION, RECONSTRUCTION, ALTERATION, REPAIR, IMPROVEMENT OR MAINTENANCE OF PUBLIC WORKS, WHERE THE COST IS MORE THAN \$50,000 AND, IN THE CASE OF STEEL ONLY, WHERE THE COST OF STEEL IS MORE THAN \$50,000 OR WHERE MORE THAN 10,000 POUNDS OF STEEL ARE REQUIRED, THE STATE WILL ACCEPT ONLY ALUMINUM GLASS, OR STEEL PRODUCTS PRODUCED IN THE UNITED STATES IN ADDITION, ITEMS OF MACHINERY OR EQUIPMENT PURCHASED FOR USE AT THE SITE OF PUBLIC WORKS SHALL BE MADE OF DOMESTIC ALUMINUM, GLASS OR STEEL, UNLESS THE COST OF THE PRODUCT IS LESS THAN \$50,000 OR LESS THAN 10,000 POUNDS OF STEEL ARE USED IN PUBLIC WORKS PROJECTS.</p> <p>FOREIGN MADE ALUMINUM, GLASS OR STEEL PRODUCTS MAY BE ACCEPTED ONLY IF THE COST OF DOMESTIC PRODUCTS IS FOUN</p>		

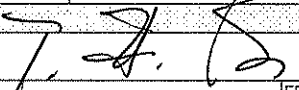
SEE REVERSE SIDE FOR TERMS AND CONDITIONS			
SIGNATURE 	TELEPHONE (304) 345-1253	DATE 11/14/2006	
TITLE President	FEIN 55-0585404	ADDRESS CHANGES TO BE NOTED ABOVE	

WHEN RESPONDING TO RFQ, INSERT NAME AND ADDRESS IN SPACE ABOVE LABELED 'VENDOR'



State of West Virginia
 Department of Administration
 Purchasing Division
 2019 Washington Street East
 Post Office Box 50130
 Charleston, WV 25305-0130

Request for Quotation

RFQ NUMBER
 PRS07003

PAGE
 5

ADDRESS CORRESPONDENCE TO ATTENTION OF:
 CHUCK BOWMAN
 304-558-2157

*406110534 304-345-1253
 PROGRESSIVE ELECTRIC INC
 PO BOX 3695
 CHARLESTON WV 25336

VENDOR

SHIP TO

PROTECTIVE SERVICES
 DIVISION OF
 BUILDING 1, ROOM 152-A
 1900 KANAWHA BOULEVARD, EAST
 CHARLESTON, WV
 25305 304-558-9911

DATE PRINTED 10/20/2006	TERMS OF SALE	SHIP VIA	F.O.B.	FREIGHT TERMS
BID OPENING DATE: 11/14/2006		BID OPENING TIME 01:30PM		

LINE	QUANTITY	UOP	CAT NO	ITEM NUMBER	UNIT PRICE	AMOUNT
<p>TO BE UNREASONABLE. SUCH COST IS UNREASONABLE IF IT IS 20% OR MORE HIGHER THAN THE BID PRICE FOR FOREIGN MADE PRODUCTS. IF THE DOMESTIC ALUMINUM, GLASS OR STEEL PRODUCTS TO BE SUPPLIED OR PRODUCED IN A "SUBSTANTIAL LABOR SURPLUS AREA", AS DEFINED BY THE UNITED STATES DEPARTMENT OF LABOR, FOREIGN PRODUCTS MAY BE SUPPLIED ONLY IF DOMESTIC PRODUCTS ARE 30% OR MORE HIGHER IN PRICE THAN THE FOREIGN MADE PRODUCTS.</p> <p>IF, PRIOR TO THE AWARD OF A CONTRACT UNDER THE ABOVE PROVISIONS, THE SPENDING OFFICER OF THE SPENDING UNIT DETERMINES THAT THERE EXISTS A BID FOR LIKE FOREIGN ALUMINUM, GLASS OR STEEL THAT IS REASONABLE AND LOWER THAN THE LOWEST BID DOMESTIC PRODUCTS, THE SPENDING OFFICE MAY REQUEST, IN WRITING, A REEVALUATION AND REDUCTION IN THE LOWEST BID FOR SUCH DOMESTIC PRODUCTS. ALL VENDORS MUST INDICATE IN THEIR BID IF THEY ARE SUPPLYING FOREIGN ALUMINUM, GLASS OR STEEL.</p> <p>REV. 3/88</p> <p>EXHIBIT 9</p> <p>NOTICE FOR ISSUANCE & ACKNOWLEDGEMENT OF CONSTRUCTION PROJECT ADDENDA</p> <p>THE ARCHITECT/ENGINEER AND/OR AGENCY SHALL BE REQUIRED TO ABIDE BY THE FOLLOWING SCHEDULE IN ISSUING CONSTRUCTION PROJECT ADDENDA FOR STATE AGENCIES:</p> <p>(1) THE ARCHITECT/ENGINEER SHALL PREPARE THE ADDENDUM AND A LIST OF ALL PARTIES THAT HAVE PROCURED DRAWINGS AND SPECIFICATIONS FOR THE PROJECT. THE ADDENDUM AND LIST SHALL BE FORWARDED TO THE BUYER IN THE STATE PURCHASING DIVISION. THE ARCHITECT/ENGINEER SHALL ALS</p>						

SEE REVERSE SIDE FOR TERMS AND CONDITIONS

SIGNATURE 	TELEPHONE (304) 345-1253	DATE 11/14/2006
TITLE President	FEIN 55-0585404	ADDRESS CHANGES TO BE NOTED ABOVE

WHEN RESPONDING TO RFQ, INSERT NAME AND ADDRESS IN SPACE ABOVE LABELED 'VENDOR'



State of West Virginia
 Department of Administration
 Purchasing Division
 2019 Washington Street East
 Post Office Box 50130
 Charleston, WV 25305-0130

Request for Quotation

RFQ NUMBER
 PRS07003

PAGE
 6

ADDRESS CORRESPONDENCE TO ATTENTION OF:
 CHUCK BOWMAN
 304-558-2157

*406110534 304-345-1253
 PROGRESSIVE ELECTRIC INC
 PO BOX 3695

CHARLESTON WV 25336

VENDOR

SHIP TO

PROTECTIVE SERVICES
 DIVISION OF
 BUILDING 1, ROOM 152-A
 1900 KANAWHA BOULEVARD, EAST
 CHARLESTON, WV
 25305 304-558-9911

DATE PRINTED	TERMS OF SALE	SHIP VIA	F.O.B.	FREIGHT TERMS
10/20/2006				
BID OPENING DATE: 11/14/2006		BID OPENING TIME 01:30PM		

LINE	QUANTITY	UOP	CAT NO	ITEM NUMBER	UNIT PRICE	AMOUNT
				<p>SEND A COPY OF THE ADDENDUM TO THE STATE AGENCY FOR WHICH THE CONTRACT IS ISSUED.</p> <p>(2) THE BUYER SHALL SEND THE ADDENDUM TO ALL INTERESTED PARTIES AND, IF NECESSARY, EXTEND THE BID OPENING DATE. ANY ADDENDUM SHOULD BE RECEIVED BY THE BUYER WITHIN FOURTEEN (14) DAYS PRIOR TO THE BID OPENING DATE.</p> <p>(3) ALL ADDENDA SHOULD BE FORMALLY ACKNOWLEDGED BY ALL BIDDERS AND SUBMITTED TO THE STATE PURCHASING DIVISION AND THE STATE AUDITOR'S OFFICE. THE SAME RULES AND REGULATIONS THAT APPLY TO THE ORIGINAL BIDDING DOCUMENT SHALL ALSO APPLY TO AN ADDENDUM DOCUMENT. THE ONLY EXCEPTION MAY BE FOR AN ADDENDUM THAT IS ISSUED FOR THE SOLE PURPOSE OF CHANGING A BID OPENING TIME AND/OR DATE.</p> <p>REV. 11/96</p> <p>EXHIBIT 10</p> <p>ADDENDUM ACKNOWLEDGEMENT</p> <p>I HEREBY ACKNOWLEDGE RECEIPT OF THE FOLLOWING CHECKED ADDENDUM(S) AND HAVE MADE THE NECESSARY REVISIONS TO MY PROPOSAL, PLANS AND/OR SPECIFICATION, ETC.</p> <p>ADDENDUM NOS.:</p> <p>NO. 1 ... N/A</p> <p>NO. 2 ... N/A</p> <p>NO. 3 ... N/A</p>		

SEE REVERSE SIDE FOR TERMS AND CONDITIONS

SIGNATURE	TELEPHONE	DATE
	(304) 345-1253	11/14/2006
TITLE	FEIN	ADDRESS CHANGES TO BE NOTED ABOVE
President	55-0585404	

WHEN RESPONDING TO RFQ, INSERT NAME AND ADDRESS IN SPACE ABOVE LABELED 'VENDOR'



State of West Virginia
 Department of Administration
 Purchasing Division
 2019 Washington Street East
 Post Office Box 50130
 Charleston, WV 25305-0130

Request for Quotation

RFQ NUMBER
 PRS07003

PAGE
 7

ADDRESS CORRESPONDENCE TO ATTENTION OF:
 CHUCK BOWMAN
 304-558-2157

*406110534 304-345-1253
 PROGRESSIVE ELECTRIC INC
 PO BOX 3695

CHARLESTON WV 25336

VENDOR

SHIP TO

PROTECTIVE SERVICES
 DIVISION OF
 BUILDING 1, ROOM 152-A
 1900 KANAWHA BOULEVARD, EAST
 CHARLESTON, WV
 25305 304-558-9911

DATE PRINTED 10/20/2006	TERMS OF SALE	SHIP VIA	F.O.B.	FREIGHT TERMS
BID OPENING DATE: 11/14/2006		BID OPENING TIME 01:30PM		

LINE	QUANTITY	UOP	CAT. NO.	ITEM NUMBER	UNIT PRICE	AMOUNT
NO. 4		N/A				
NO. 5		N/A				
<p>I UNDERSTAND THAT FAILURE TO CONFIRM THE RECEIPT OF TH ADDENDUM(S) MAY BE CAUSE FOR REJECTION OF THE BIDS.</p> <p>..... SIGNATURE</p> <p>Progressive Electric, Inc. COMPANY</p> <p>11/14/06 DATE</p> <p>REV. 11/96</p> <p>CONTRACTORS LICENSE</p> <p>WEST VIRGINIA STATE CODE 21-11-2 REQUIRES THAT ALL PERSONS DESIRING TO PERFORM CONTRACTING WORK IN THIS STATE MUST BE LICENSED. THE WEST VIRGINIA CONTRACTORS LICENSING BOARD IS EMPOWERED TO ISSUE THE CONTRACTORS LICENSE. APPLICATIONS FOR A CONTRACTORS LICENSE MAY BE MADE BY CONTACTING THE WEST VIRGINIA DIVISION OF LABOR CAPITOL COMPLEX, BUILDING 3, ROOM 319, CHARLESTON, WV 25305. TELEPHONE: (304) 558-7890.</p> <p>WEST VIRGINIA STATE CODE 21-11-11 REQUIRES ANY PROSPECTIVE BIDDER TO INCLUDE THE CONTRACTORS LICENSE NUMBER ON THEIR BID.</p> <p>BIDDER TO COMPLETE:</p>						

SEE REVERSE SIDE FOR TERMS AND CONDITIONS			
SIGNATURE <i>T. J. B.</i>	TELEPHONE (304) 345-1253	DATE 11/14/2006	
TITLE President	FEIN 55-0585404	ADDRESS CHANGES TO BE NOTED ABOVE	

WHEN RESPONDING TO RFQ, INSERT NAME AND ADDRESS IN SPACE ABOVE LABELED 'VENDOR'



State of West Virginia
 Department of Administration
 Purchasing Division
 2019 Washington Street East
 Post Office Box 50130
 Charleston, WV 25305-0130

Request for Quotation

RFQ NUMBER
 PRS07003

PAGE
 8

ADDRESS CORRESPONDENCE TO ATTENTION OF:
 CHUCK BOWMAN
 304-558-2157

*406110534 304-345-1253
 PROGRESSIVE ELECTRIC INC
 PO BOX 3695

CHARLESTON WV 25336

VENDOR

SHIP TO

PROTECTIVE SERVICES
 DIVISION OF
 BUILDING 1, ROOM 152-A
 1900 KANAWHA BOULEVARD, EAST
 CHARLESTON, WV
 25305 304-558-9911

DATE PRINTED 10/20/2006	TERMS OF SALE	SHIP VIA	F.O.B.	FREIGHT TERMS
BID OPENING DATE: 11/14/2006		BID OPENING TIME 01:30PM		

LINE	QUANTITY	UOP	CAT NO	ITEM NUMBER	UNIT PRICE	AMOUNT
<p>CONTRACTORS NAME: ... <i>PROGRESSIVE ELECTRIC, INC.</i> ...</p> <p>CONTRACTORS LICENSE NO.: ... <i># 5</i> ...</p> <p>THE SUCCESSFUL BIDDER WILL BE REQUIRED TO FURNISH A COPY OF THEIR CONTRACTORS LICENSE PRIOR TO ISSUANCE OF A PURCHASE ORDER/CONTRACT</p> <p>APPLICABLE LAW</p> <p>THE WEST VIRGINIA STATE CODE, PURCHASING DIVISION RULES AND REGULATIONS, AND THE INFORMATION PROVIDED IN THE "REQUEST FOR QUOTATION" ISSUED BY THE PURCHASING DIVISION IS THE SOLE AUTHORITY GOVERNING THIS PROCUREMENT.</p> <p>ANY INFORMATION PROVIDED IN SPECIFICATION MANUALS, OR ANY OTHER SOURCE, VERBAL OR WRITTEN, WHICH CONTRADICTS OR ALTERS THE INFORMATION PROVIDED FROM THE SOURCES AS DESCRIBED IN THE ABOVE PARAGRAPH IS VOID AND OF NO EFFECT.</p> <p>BANKRUPTCY: IN THE EVENT THE VENDOR/CONTRACTOR FILES FOR BANKRUPTCY PROTECTION, THIS CONTRACT IS AUTOMATICALLY NULL AND VOID, AND IS TERMINATED WITHOUT FURTHER ORDER.</p> <p>REV. 1/2005</p> <p>NOTICE</p> <p>A SIGNED BID MUST BE SUBMITTED TO:</p> <p>DEPARTMENT OF ADMINISTRATION PURCHASING DIVISION</p>						

SEE REVERSE SIDE FOR TERMS AND CONDITIONS			
SIGNATURE <i>T. J. B.</i>	TELEPHONE (304) 345-1253	DATE 11/14/2006	
TITLE President	FEIN 55-0585404	ADDRESS CHANGES TO BE NOTED ABOVE	

WHEN RESPONDING TO RFQ, INSERT NAME AND ADDRESS IN SPACE ABOVE LABELED 'VENDOR'



State of West Virginia
 Department of Administration
 Purchasing Division
 2019 Washington Street East
 Post Office Box 50130
 Charleston, WV 25305-0130

Request for Quotation

RFQ NUMBER
 PRS07003

PAGE
 9

ADDRESS CORRESPONDENCE TO ATTENTION OF:
 CHUCK BOWMAN
 304-558-2157

VENDOR

*406110534 304-345-1253
 PROGRESSIVE ELECTRIC INC
 PO BOX 3695
 CHARLESTON WV 25336

SHIP TO

PROTECTIVE SERVICES
 DIVISION OF
 BUILDING 1, ROOM 152-A
 1900 KANAWHA BOULEVARD, EAST
 CHARLESTON, WV
 25305 304-558-9911

DATE PRINTED 10/20/2006	TERMS OF SALE	SHIP VIA	F.O.B.	FREIGHT TERMS
BID OPENING DATE: 11/14/2006		BID OPENING TIME 01:30PM		

LINE	QUANTITY	UOP	CAT. NO.	ITEM NUMBER	UNIT PRICE	AMOUNT
BUILDING 15 2019 WASHINGTON STREET, EAST CHARLESTON, WV 25305-0130 THE BID SHOULD CONTAIN THIS INFORMATION ON THE FACE OF THE ENVELOPE OR THE BID MAY NOT BE CONSIDERED: SEALED BID BUYER: CB-23 REQ. NO.: PRS07003 BID OPENING DATE: 11/14/2006 BID OPENING TIME: 1:30 PM PLEASE PROVIDE A FAX NUMBER IN CASE IT IS NECESSARY TO CONTACT YOU REGARDING YOUR BID: 304-345-1256 ----- PLEASE PRINT OR TYPE NAME OF PERSON TO CONTACT CONCERNING THIS QUOTE: T. H. BRAOY -----						

SEE REVERSE SIDE FOR TERMS AND CONDITIONS.			
SIGNATURE <i>T. H. Braoy</i>	TELEPHONE (304) 345-1253	DATE 11/14/2006	
TITLE President	FEIN 55-0585404	ADDRESS CHANGES TO BE NOTED ABOVE	

WHEN RESPONDING TO RFQ, INSERT NAME AND ADDRESS IN SPACE ABOVE LABELED 'VENDOR'

BID BOND

KNOW ALL MEN BY THESE PRESENTS, That we, the undersigned, Progressive Electric, Inc.
of Charleston, WV, as Principal, and Ohio Farmers Insurance
Compan of Westfield Center, OH, a corporation organized and existing under the laws of the State of OH
OH with its principal office in the City of Westfield Center, as Surety, are held and firmly bound unto the State
of West Virginia, as Obligee, in the penal sum of Five Percent of Amount Bid (\$ 5%) for the payment of which,
well and truly to be made, we jointly and severally bind ourselves, our heirs, administrators, executors, successors and assigns.

The Condition of the above obligation is such that whereas the Principal has submitted to the Purchasing Section of the
Department of Administration a certain bid or proposal, attached hereto and made a part hereof, to enter into a contract in writing for
PRS07003 Uninterruptible Power Supply, Capitol Complex, Charleston, WV

NOW THEREFORE,

- (a) If said bid shall be rejected, or
- (b) If said bid shall be accepted and the Principal shall enter into a contract in accordance with the bid or proposal attached
hereto and shall furnish any other bonds and insurance required by the bid or proposal, and shall in all other respects perform the
agreement created by the acceptance of said bid, then this obligation shall be null and void, otherwise this obligation shall remain in full
force and effect. It is expressly understood and agreed that the liability of the Surety for any and all claims hereunder shall, in no event,
exceed the penal amount of this obligation as herein stated.

The Surety, for the value received, hereby stipulates and agrees that the obligations of said Surety and its bond shall be in no
way impaired or affected by any extension of the time within which the Obligee may accept such bid, and said Surety does hereby
waive notice of any such extension.

IN WITNESS WHEREOF, Principal and Surety have hereunto set their hands and seals, and such of them as are corporations
have caused their corporate seals to be affixed hereunto and these presents to be signed by their proper officers, this
14th day of November, 2006.

Principal Corporate Seal

Progressive Electric, Inc.
(Name of Principal)
By: [Signature]
(Must be President or
Vice President)
PRESIDENT
(Title)

Surety Corporate Seal

Ohio Farmers Insurance Company
(Name of Surety)
By: [Signature]
Douglas P. Taylor Attorney-in-Fact

IMPORTANT – Surety executing bonds must be licensed in West Virginia to transact surety insurance. Corporate seals must be affixed,
and a power of attorney must be attached.

General Power of Attorney

Westfield Insurance Co. Westfield National Insurance Co. Ohio Farmers Insurance Co. Westfield Center, Ohio

CERTIFIED COPY

Know All Men by These Presents, That WESTFIELD INSURANCE COMPANY, WESTFIELD NATIONAL INSURANCE COMPANY and OHIO FARMERS INSURANCE COMPANY, corporations, hereinafter referred to individually as a "Company" and collectively as "Companies," duly organized and existing under the laws of the State of Ohio, and having its principal office in Westfield Center, Medina County, Ohio, do by these presents make, constitute and appoint

ANDREW K. TEETER, KIMBERLY L. MILES, JANIS KAY PEACOCK, DOUGLAS P. TAYLOR, PAMELA D. OBRIEN, DONNA J. PRICE, TRAVIS A. HILL, JR., PAMELA V. LANHAM, JOINTLY OR SEVERALLY

of CHARLESTON and State of WV its true and lawful Attorney(s)-in-Fact, with full power and authority hereby conferred in its name, place and stead, to execute, acknowledge and deliver any and all bonds, recognizances, undertakings, or other instruments or contracts of suretyship-

LIMITATION: THIS POWER OF ATTORNEY CANNOT BE USED TO EXECUTE NOTE GUARANTEE, MORTGAGE DEFICIENCY, MORTGAGE GUARANTEE, OR BANK DEPOSITORY BONDS.

and to bind any of the Companies thereby as fully and to the same extent as if such bonds were signed by the President, sealed with the corporate seal of the applicable Company and duly attested by its Secretary, hereby ratifying and confirming all that the said Attorney(s)-in-Fact may do in the premises. Said appointment is made under and by authority of the following resolution adopted by the Board of Directors of each of the WESTFIELD INSURANCE COMPANY, WESTFIELD NATIONAL INSURANCE COMPANY and OHIO FARMERS INSURANCE COMPANY:

"Be it Resolved, that the President, any Senior Executive, any Secretary or any Fidelity & Surety Operations Executive or other Executive shall be and is hereby vested with full power and authority to appoint any one or more suitable persons as Attorney(s)-in-Fact to represent and act for and on behalf of the Company subject to the following provisions:

The Attorney-in-Fact. may be given full power and authority for and in the name of and on behalf of the Company, to execute, acknowledge and deliver, any and all bonds, recognizances, contracts, agreements of indemnity and other conditional or obligatory undertakings and any and all notices and documents canceling or terminating the Company's liability thereunder, and any such instruments so executed by any such Attorney-in-Fact shall be as binding upon the Company as if signed by the President and sealed and attested by the Corporate Secretary."

"Be it Further Resolved, that the signature of any such designated person and the seal of the Company heretofore or hereafter affixed to any power of attorney or any certificate relating thereto by facsimile, and any power of attorney or certificate bearing facsimile signatures or facsimile seal shall be valid and binding upon the Company with respect to any bond or undertaking to which it is attached." (Each adopted at a meeting held on February 8, 2000).

In Witness Whereof, WESTFIELD INSURANCE COMPANY, WESTFIELD NATIONAL INSURANCE COMPANY and OHIO FARMERS INSURANCE COMPANY have caused these presents to be signed by their Senior Executive and their corporate seals to be hereto affixed this 19th day of JUNE A.D., 2006 .

Corporate Seals Affixed



WESTFIELD INSURANCE COMPANY WESTFIELD NATIONAL INSURANCE COMPANY OHIO FARMERS INSURANCE COMPANY

Richard L. Kinnaird, Jr. (Signature)

By: Richard L. Kinnaird, Jr., Senior Executive

State of Ohio County of Medina ss.:

On this 19th day of JUNE A.D., 2006 , before me personally came Richard L. Kinnaird, Jr. to me known, who, being by me duly sworn, did depose and say, that he resides in Medina, Ohio; that he is Senior Executive of WESTFIELD INSURANCE COMPANY, WESTFIELD NATIONAL INSURANCE COMPANY and OHIO FARMERS INSURANCE COMPANY, the companies described in and which executed the above instrument; that he knows the seals of said Companies; that the seals affixed to said instrument are such corporate seals; that they were so affixed by order of the Boards of Directors of said Companies; and that he signed his name thereto by like order.

Notarial Seal Affixed



William J. Kahelin (Signature)

William J. Kahelin, Attorney at Law, Notary Public My Commission Does Not Expire (Sec. 147.03 Ohio Revised Code)

State of Ohio County of Medina ss.:

I, Frank A. Carrino, Secretary of WESTFIELD INSURANCE COMPANY, WESTFIELD NATIONAL INSURANCE COMPANY and OHIO FARMERS INSURANCE COMPANY, do hereby certify that the above and foregoing is a true and correct copy of a Power of Attorney, executed by said Companies, which is still in full force and effect; and furthermore, the resolutions of the Boards of Directors, set out in the Power of Attorney are in full force and effect.

In Witness Whereof, I have hereunto set my hand and affixed the seals of said Companies at Westfield Center, Ohio, this 14th day of November A.D., 2006



Frank A. Carrino (Signature) Secretary



PROGRESSIVE ELECTRIC, INC.

P. O. BOX 3695
CHARLESTON, WV 25336
WV CONTRACTOR LICENSE WV 00005

PHONE:
(304) 345-1253
FAX:
(304) 345-1256

Optional Price Attachment

Mitsubishi UPS Instead of MGE UPS

2033C Series

UNINTERRUPTIBLE POWER
SUPPLY SYSTEMS

10kVA – 50kVA

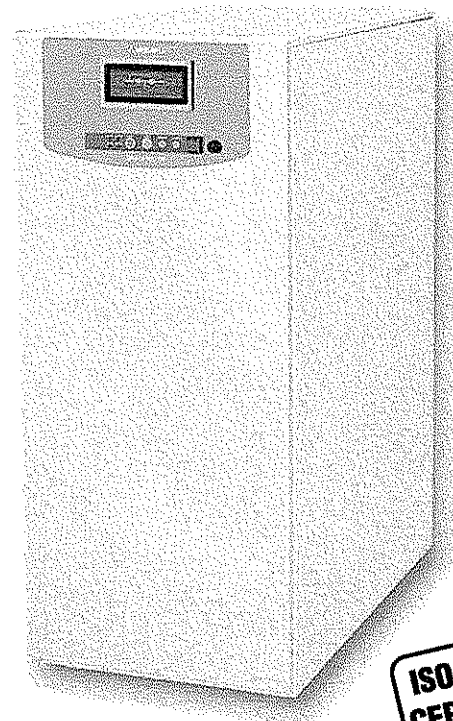

ISO 9001
CERTIFIED

**Where Reliability
Breeds Confidence**

 **MITSUBISHI ELECTRIC**

Superior Performance, Reliability and Safety Come from Experience. Our Uninterruptible Power Supply Systems Ensure All Three.

Mitsubishi Electric has been developing and manufacturing Uninterruptible Power Supply (UPS) components and systems for more than three decades. This experience, and the continuous application of new power device technologies to further improve products in the industry, clearly explain why Mitsubishi Electric has dominated a large portion of the world UPS market for years.

When purchasing a UPS system, the key word is "reliability." And there's one company that many rely on. Uninterruptible Power Supply systems by Mitsubishi Electric.

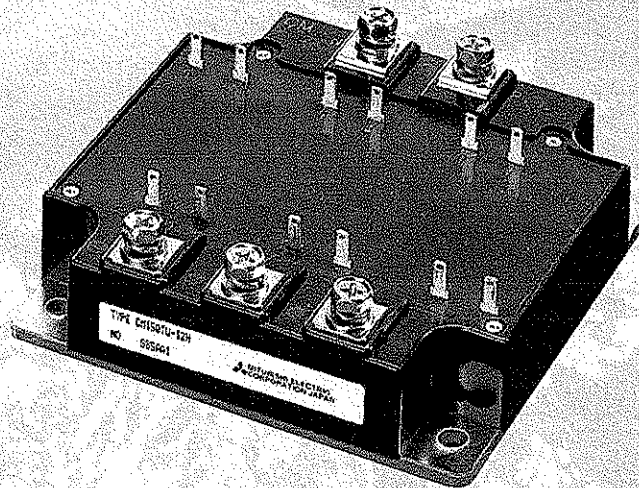

Full IGBT Transistors – Excellent Performance Characteristics

Mitsubishi Electric is the leading manufacturer of Insulated Gate Bipolar Transistors (IGBT). Mitsubishi Electric utilizes IGBTs in the converter and inverter sections of our 2033C Series UPS systems. These advanced, high performance transistors

provide a variety of intelligent features:

- Large power capabilities
- High speed switching
- Low control power consumption

Low Input Current Harmonics (THD)

- 4% typical (100% load)
- 5% typical (75% load)
- 7% typical (50% load)

Input Power Factor

- 1:1 ratio

Low Heat Loss/High Efficiency

Use of the IGBTs permits efficient high speed switching (16kHz or 12kHz), thus reducing heat dissipation in the UPS. (Higher efficiency means lower cost per kilowatt to the customer.)

TECHNICALLY, ANY

One-Line Diagram

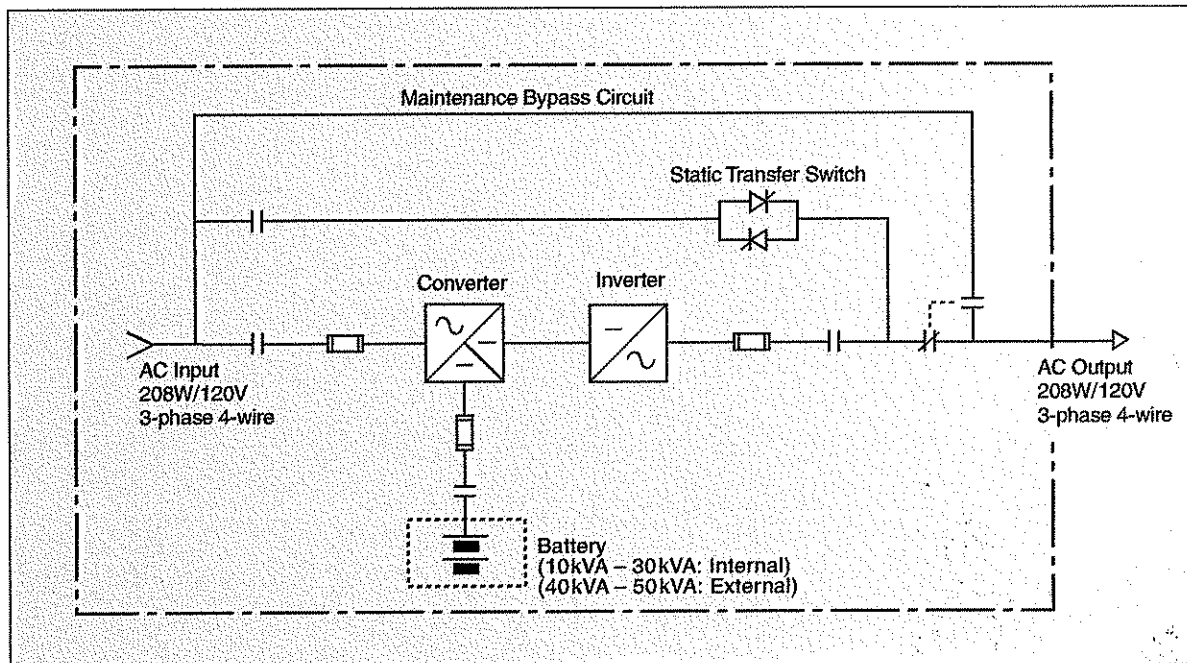

Software

What is DiamondLink™?

DiamondLink is user-customizable power monitoring, management and shutdown software, designed to provide information about the power condition of the UPS systems.

How does DiamondLink work?

DiamondLink is designed to run on network server or workstations in any office environment. The software will monitor the status of your UPS and, when critical events occur, will perform a graceful unattended shutdown.

Features

- Automatic unattended shutdown.
- Color coded power event logging.
- Smart messages can be user defined.
- User defined actions for a specific list of power events.
- Built-in graphing routines allow customized graphs to be created on-line.
- DiamondLink can be used with all Mitsubishi single phase and three phase products.

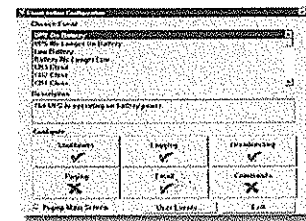
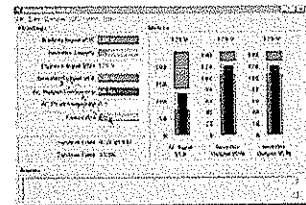

Specifics

- Power history graph
- Custom user defined events
- Data log viewer
- E-mail configurations
- E-mail options for power events
- Event action
- Events log file
- Modem alert operation
- Pager notification
- Paging option

Supported Operating Systems

- Microsoft Windows®
- Microsoft Windows NT
- Microsoft Windows 95
- Microsoft Windows 98
- Microsoft Windows 00
- OS/2
- Novel NetWare®
- SVR4
- SCO UNIX
- SCO XENIX
- Solaris™
- IBM® AIX®-RS6000™
- HP-UX
- SGI
- Digital UNIX
- RED HAT LINUX

THING IS POSSIBLE

NEW



Battery Included

- All in one
- Reduced foot print

Extended Battery Life

Power draw from batteries during step load conditions is no longer required with the IGBT in both the converter and the inverter. Other UPS systems required assistance from batteries when the converter was unable to supply the required current. This cycling of batteries causes shorter life. Mitsubishi Electric IGBTs incorporate the latest technologies and provide step load applications (0-100%) without the use of batteries, thus ensuring maximum battery service life (i.e. lower lifetime cost of UPS system).

Quiet Operation

- 10-20kVA→55dB (A scale, 1m)
- 30-50kVA→59dB (A scale, 1m)

Internal Maintenance Bypass (in addition to Static bypass)

All 2033C Series UPS systems are equipped with an internal wrap around "Zero Energy" maintenance bypass system for greater maintenance flexibility.

Superior Functions

- Front access only
- Automatic restart after low battery inverter stop
- Automatic retransfer
- Converter walk-in function
- "Form A" dry contacts
- High tolerance for overload/overcurrent
- Battery current limit
- Battery self test

Touch screen display allows user to access:

- Input/Output voltage
- Input/Output current
- KW
- Frequency
- Battery information
 - Charge voltage
 - Discharge voltage
- Diagnostics
 - Fault/Alarm history

Software

- RS-232C serial interface (Standard)
- DiamondLink application software (Optional)
 - Multilingual
 - Paging, E-mail capability during power events
 - SNMP interface (NETCOM)

Warranty

Standard warranty is two years, including parts, labor and batteries.

(NOTE: All information subject to change without prior notice.)



SPECIFICATIONS

UPS Voltage Configurations

kVA	208V to 208V Dimensions (in) W x D x H	208V to 208V Weight (lbs)	480V (or 600V) to 208V Dimensions (in) W x D x H	480V (or 600V) to 208V Weight (lbs)	*480V to 480V Dimensions (in) W x D x H	*480V to 480V Weight (lbs)
10	17.7 x 31.5 x 43.3	562	35.4 x 31.5 x 43.3	935	53.1 x 31.5 x 43.3	1,570
15	17.7 x 31.5 x 43.3	816	35.4 x 31.5 x 43.3	1,111	53.1 x 31.5 x 43.3	1,796
20	17.7 x 31.5 x 43.3	816	35.4 x 31.5 x 43.3	1,186	53.1 x 31.5 x 43.3	1,946
30	23.6 x 31.5 x 59.1	1,322	51.1 x 31.5 x 59.1	1,957	51.1 x 31.5 x 59.1	2,242
40	27.6 x 31.5 x 59.1	1,082	55.1 x 31.5 x 59.1	1,767	55.1 x 31.5 x 59.1	2,102
50	27.6 x 31.5 x 59.1	1,082	55.1 x 31.5 x 59.1	1,842	55.1 x 31.5 x 59.1	2,252

*Same for 600V input/600V output

NOTES: Batteries included (10 kVA 5 min., 15 kVA 11 min., 20 kVA 7 min., 30 kVA 6 min. at 100% load)

Above weights for 10-30kVA include batteries.

Standard Features

- IGBT (Converter/Inverter)
- UL1778/cUL listed
- UL924 listed
- Zero energy MBS
- Conformally coated boards (industrial environment)
- Front access only (Serviceability)
- "DiamondSense" battery self-test

Battery DC Link

- 360 VDC

Operating Environment

- Low acoustic noise
- Temperature: 0~40°C
- Relative humidity: 5~95% (non-condensing)
- Altitude: 0-9,000 feet (no derating)

Options

- Seismic bracing brackets
- 480V Input (external matching cabinet)
- Software (for specific O/S systems)

AC Input Rating

- +15% ~ -25%
- Power: Rated 1kVA : 1kW Generator
- 208Y/120 VAC
- THD (reflected current):
4% typical (100% load)
7% typical (50% load)
- 3-phase, 4-wire, plus ground
- Frequency: 60Hz (±5%)
- Surge withstand: Meets IEEE C62.41-1991
- EMI compatibility: FCC Title 47, Part 15 Subpart B

AC Output Rating

- 3-phase, 4-wire, plus ground
- 208Y/120 VAC
- Output power factor rating: 0.8~1.0 Lag (within output kW rating)
- Frequency: 60Hz ±0.01% (free running)
- Voltage accuracy: ±1%
- Transient recovery time: 16.7ms
- Load unbalance: 100% ±2% or less
- Step load change: 0~100% ±3%
- Load/Return of AC power: ±1% (at 100% load)
- UPS load transfer, bypass: ±3% (at 100% load)
- THD (Voltage): 2% (100% linear load);
4% (100% non-linear load)
- Slew rate: 1, 2Hz/sec (selectable)

2033C Series

UNINTERRUPTIBLE POWER SUPPLY SYSTEMS

10kVA – 50kVA

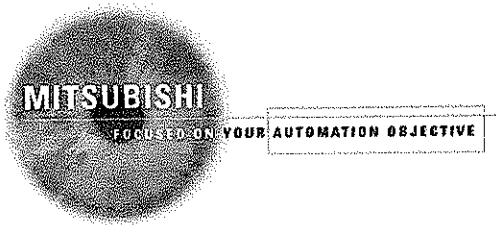

Corporate Headquarters:

Mitsubishi Electric Automation, Inc.
500 Corporate Woods Parkway
Vernon Hills, IL 60061
Phn: (847) 478-2100
Fax: (847) 478-2253
www.meau.com

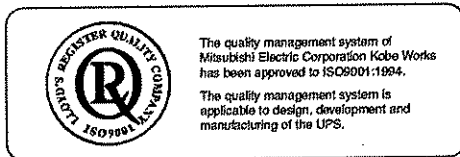

L-VH-08177 Printed in USA
Effective February, 2005
Specifications and products offered
subject to change without notice.

 **MITSUBISHI ELECTRIC**

記簿 AZ22794

ENGINEERING ORD.	
SERIAL NUMBER	

MITSUBISHI ELECTRIC CORPORATION

MITSUBISHI 2033C-B SERIES UPS

PURCHASER

SCHEMATIC DIAGRAM LIST

PROJECT 20kVA(208V) UL LISTED UPS

SITE

PAGE NO.	SHEET NO.	REVISION NO.	TITLE
001	A01		SCHEMATIC DIAGRAM LIST
002	E01		SYSTEM CONFIGURATION
003	J01		OUT LINE
004	K01		CONTROL PANEL

W10版
CAD

出図先
DF
UPSR

MITSUBISHI ELECTRIC	SCHEMATIC DIAGRAM	SHEET NO. A01
MAR. 22. 02	LIST	
T.KOJIMA		
T.KOJIMA		
AZ22794		PAGE NO. 001 / 004

圖號 AZ22794
 記錄
 UP338U
 E01
 97-03

Win版
 CAD

DF	出圖先
UPSR	

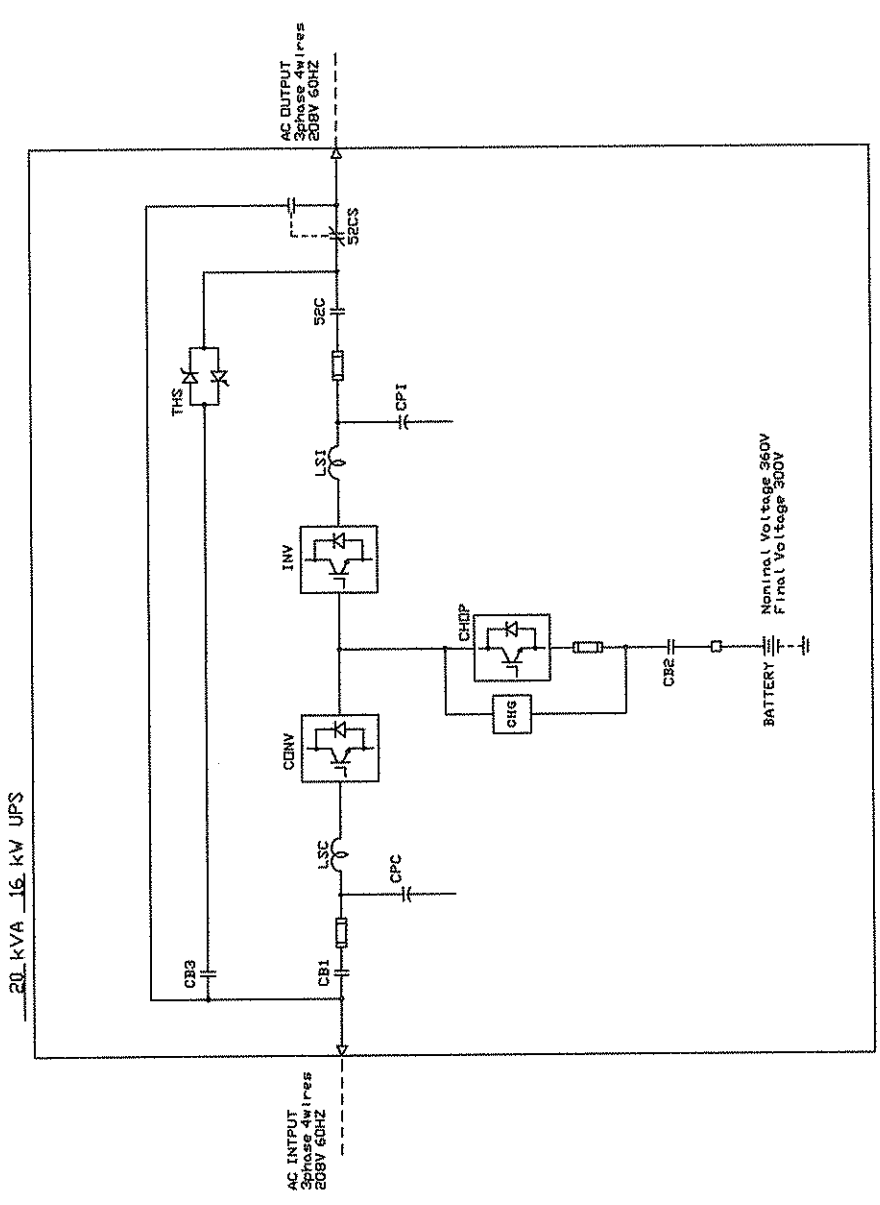

20 kVA 16 kW UPS

SHEET NO. E01	SYSTEM CONFIGURATION	
PAGE NO. 002	AZ22794	
MITSUBISHI ELECTRIC	MAR. 22. 02	
設計 T. KUDYA	校核 T. KUDYA	
設計 T. KUDYA	校核 T. KUDYA	

図番 A722794
記 録
UP2240
20KVA

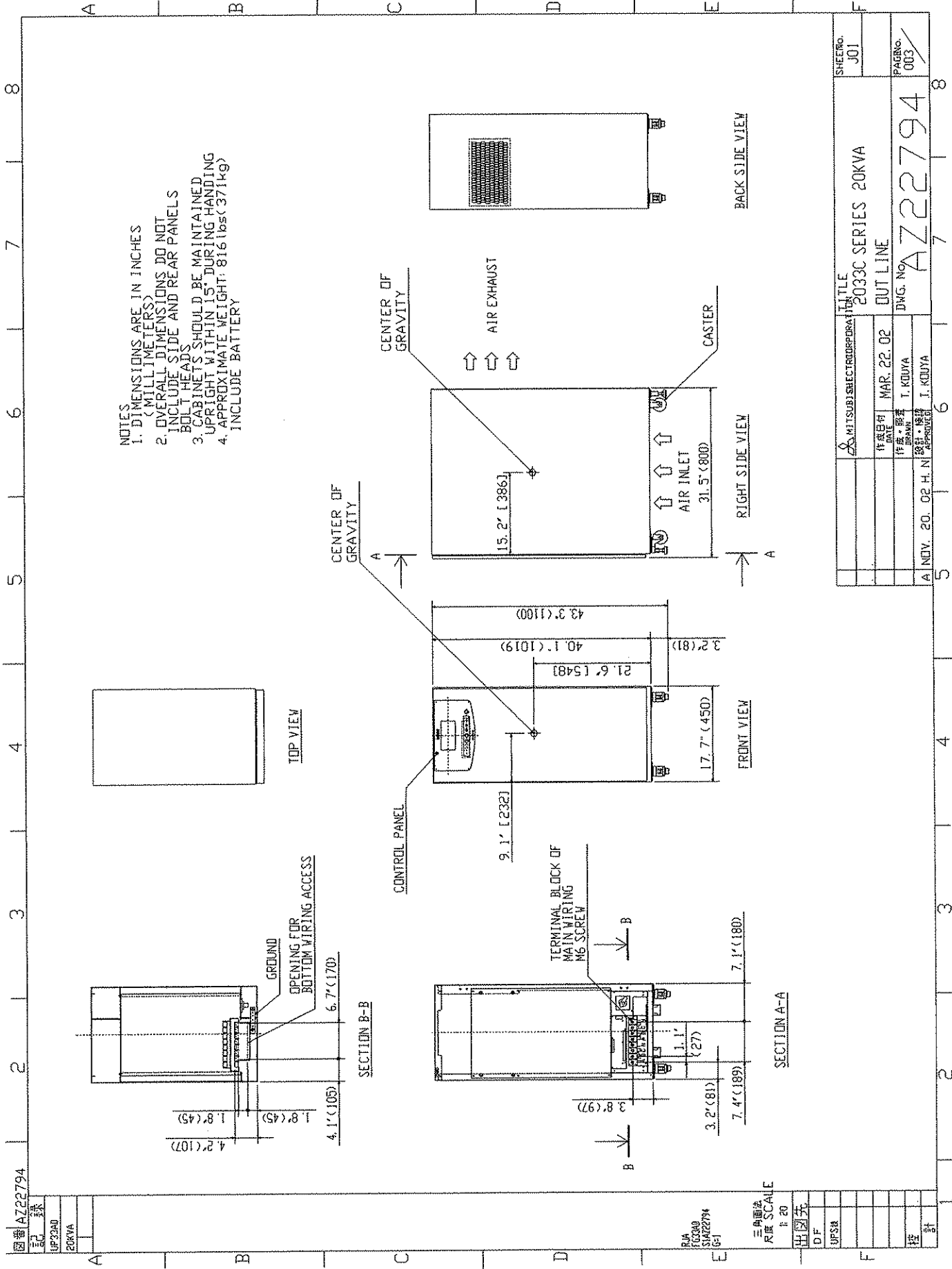

尺 寸
UP2240
SU22794
64

三 角 法
尺 底 尺 寸
1:20
出 図 先
D/F
UPFSH

出 図 先	
D/F	
UPFSH	
計 画	
監 査	

SHEET NO. J01		PAGE NO. 003	
MITSUBISHI ELECTRIC CORPORATION			
TITLE 2033C SERIES 20KVA			
DATE MAR. 22. 02		DRAWING NO. A722794	
DESIGNED BY I. KUDYA		APPROVED BY I. KUDYA	
A INDY. 20. 02 H. N. APPROVED			

圖號 AZ22794
記錄

UP2540
20KVA

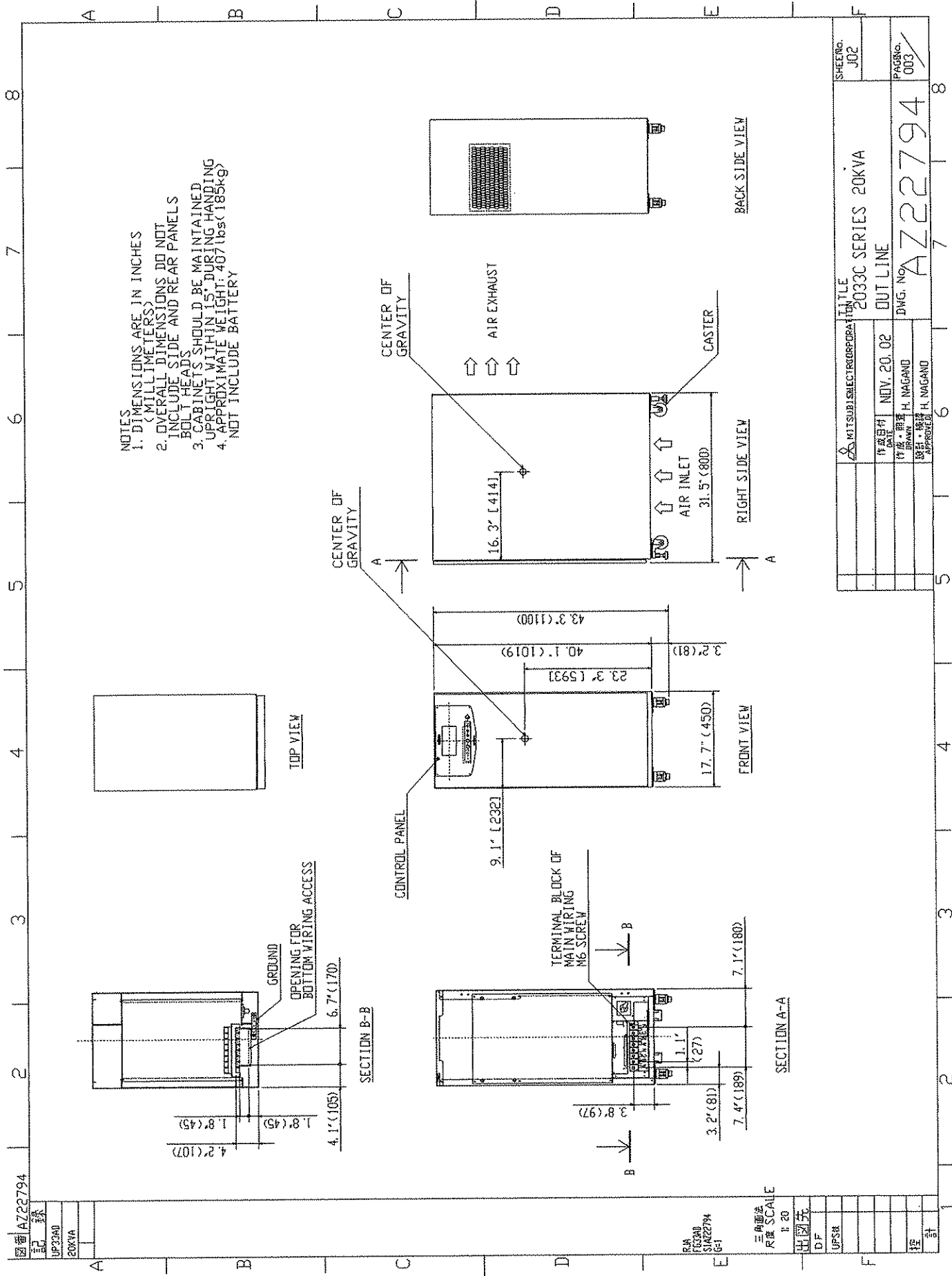

NOTES
 1. DIMENSIONS ARE IN INCHES (MILLIMETERS)
 2. OVERALL DIMENSIONS DO NOT INCLUDE SIDE AND REAR PANELS BOLT HEADS
 3. CABINETS SHOULD BE MAINTAINED UPRIGHT WITHIN 15° DURING HANDLING
 4. APPROXIMATE WEIGHT: 407 lbs (185 kg)
 NOT INCLUDE BATTERY

MITSUBISHI ELECTRIC CORPORATION		SHEET NO. J02	
2033C SERIES 20KVA		PAGE NO. 003	
DRAWING NO. AZ22794			
DATE	REV. 20.02	OUT LINE	
DESIGNED BY	H. NAGANO		
CHECKED BY	H. NAGANO		
APPROVED BY			

尺碼 SCALE
 1: 20
 出圖先
 DF
 UFSM

計

AZ22794

UP33AD
20K

R/A
FG3AD
S1AZ22794
6-3

NTS
REV
REV
REV

出図先

UPSR

控

社

記

号

13.1'(332)

7.5'(190)

0.2'(5)

MITSUBISHI

2033C SERIES UPS

INV. UP. BIP. UP. START
BIP. UP. FAILURE
STEP
SILENCE
CLEAR
EPO
MPC

REV. No.	K01
TITLE	CONTROL PANEL
DATE	MAR. 22. 02
DESIGNER	J. KUYA
CHECKER	J. KUYA
DATE	
DESIGNER	
CHECKER	
DATE	
REV. No.	004 / 004

AZ22794