



State of West Virginia
 Department of Administration
 Purchasing Division
 2019 Washington Street East
 Post Office Box 50130
 Charleston, WV 25305-0130

Request for Quotation

RFQ NUMBER
PRI2674

PAGE
1

ADDRESS CORRESPONDENCE TO ATTENTION OF
BUYER 32
304-558-0492

VENDOR
 *709024742 800-234-4900
NORIX GROUP INC
1000 ATLANTIC DRIVE
WEST CHICAGO IL 60185

SHIP TO
WV PRISON INDUSTRIES
617 LEON SULLIVAN WAY
CHARLESTON, WV
25301 304-558-2945

DATE PRINTED 09/18/2006	TERMS OF SALE	SHIP VIA	F.O.B.	FREIGHT TERMS
-----------------------------------	---------------	----------	--------	---------------

BID OPENING DATE: **10/11/2006** BID OPENING TIME **01:30PM**

LINE	QUANTITY	UOP	CAT NO.	ITEM NUMBER	UNIT PRICE	AMOUNT
REQUEST FOR QUOTATION						
<p>THE PURCHASING DIVISION IS SOLICITING BIDS FOR THE HUTTONSVILLE CORRECTIONAL CENTER TO PROVIDE HEAVY DUTY STORAGE BOXES, TABLES, & CHAIRS PER THE ATTACHED SPECIFICATIONS.</p> <p>ATTACHMENTS:</p> <ol style="list-style-type: none"> 1. SPECIFICATIONS 2. BID FORM 3. AFFIDAVIT <p>THE SPECIFIED ITEMS MUST BE EQUAL TO THE NORIX BRAND AND MODEL NUMBERS DESCRIBED ON THE BID FORM. FOR OTHER BRANDS BID, LITERATURE (INCLUDING PICTURES), SHALL BE SUBMITTED SPECIFYING THE QUALITY, SIZES, ETC., TO DEMONSTRATE THE BRAND AND MODELS BID ARE EQUAL TO OR BETTER THAN THE SPECIFIED ITEMS.</p> <p>DELIVERY:</p> <p>THE COMPLETE ORDER MUST BE DELIVERED WITHIN 45 DAYS UPON RECEIPT OF THE PURCHASE ORDER. THE COST OF DELIVERY SHALL BE INCLUDED IN THE BID PRICE.</p>						
0001	1	LT		420-62-04-003		
STORAGE BOXES, TABLES, & CHAIRS						

SEE REVERSE SIDE FOR TERMS AND CONDITIONS

SIGNATURE 	TELEPHONE 800-234-4900	DATE 10-5-2006
TITLE Vice President Sales	FEIN 36-3257149	ADDRESS CHANGES TO BE NOTED ABOVE

WHEN RESPONDING TO RFQ, INSERT NAME AND ADDRESS IN SPACE ABOVE LABELED 'VENDOR'



State of West Virginia
 Department of Administration
 Purchasing Division
 2019 Washington Street East
 Post Office Box 50130
 Charleston, WV 25305-0130

Request for Quotation

RFQ NUMBER
PR12674

PAGE
2

ADDRESS CORRESPONDENCE TO ATTENTION OF
BUYER 32
304-558-0492

VENDOR
 *709024742 800-234-4900
 NORIX GROUP INC
 1000 ATLANTIC DRIVE
 WEST CHICAGO IL 60185

SHIP TO
 WV PRISON INDUSTRIES
 617 LEON SULLIVAN WAY
 CHARLESTON, WV
 25301 304-558-2945

DATE PRINTED	TERMS OF SALE	SHIP VIA	F.O.B	FREIGHT TERMS
09/18/2006				

BID OPENING DATE: **10/11/2006** BID OPENING TIME **01:30PM**

LINE	QUANTITY	UOP	CAT NO.	ITEM NUMBER	UNIT PRICE	AMOUNT
<p>VENDOR PREFERENCE CERTIFICATE</p> <p>CERTIFICATION AND APPLICATION* IS HEREBY MADE FOR PREFERENCE IN ACCORDANCE WITH WEST VIRGINIA CODE, 5A-3-37 (DOES NOT APPLY TO CONSTRUCTION CONTRACTS).</p> <p>A. APPLICATION IS MADE FOR 2.5% PREFERENCE FOR THE REASON CHECKED:</p> <p>() BIDDER IS AN INDIVIDUAL RESIDENT VENDOR AND HAS RESIDED CONTINUOUSLY IN WEST VIRGINIA FOR FOUR (4) YEARS IMMEDIATELY PRECEDING THE DATE OF THIS CERTIFICATION; OR</p> <p>() BIDDER IS A PARTNERSHIP, ASSOCIATION OR CORPORATION RESIDENT VENDOR AND HAS MAINTAINED ITS HEAD-QUARTERS OR PRINCIPAL PLACE OF BUSINESS CONTINUOUSLY IN WEST VIRGINIA FOR FOUR (4) YEARS IMMEDIATELY PRECEDING THE DATE OF THIS CERTIFICATION; OR 80% OF THE OWNERSHIP INTEREST OF BIDDER IS HELD BY ANOTHER INDIVIDUAL, PARTNERSHIP, ASSOCIATION OR CORPORATION RESIDENT VENDOR WHO HAS MAINTAINED ITS HEADQUARTERS OR PRINCIPAL PLACE OF BUSINESS CONTINUOUSLY IN WEST VIRGINIA FOR FOUR (4) YEARS IMMEDIATELY PRECEDING THE DATE OF THIS CERTIFICATION; OR</p> <p>() BIDDER IS A CORPORATION NONRESIDENT VENDOR WHICH HAS AN AFFILIATE OR SUBSIDIARY WHICH EMPLOYS A MINIMUM OF ONE HUNDRED STATE RESIDENTS AND WHICH HAS MAINTAINED ITS HEADQUARTERS OR PRINCIPAL PLACE OF BUSINESS WITHIN WEST VIRGINIA CONTINUOUSLY FOR THE FOUR (4) YEARS IMMEDIATELY PRECEDING THE DATE OF THIS CERTIFICATION.</p> <p>B. APPLICATION IS MADE FOR 2.5% PREFERENCE FOR THE REASON CHECKED:</p>						

SIGNATURE TELEPHONE **800-234-4900** DATE **10-5-2006**

TITLE **Vice President Sales** FEIN **36-3257149** ADDRESS CHANGES TO BE NOTED ABOVE

WHEN RESPONDING TO RFQ, INSERT NAME AND ADDRESS IN SPACE ABOVE LABELED 'VENDOR'



State of West Virginia
 Department of Administration
 Purchasing Division
 2019 Washington Street East
 Post Office Box 50130
 Charleston, WV 25305-0130

Request for Quotation

RFQ NUMBER
PRI2674

PAGE
3

ADDRESS CORRESPONDENCE TO ATTENTION OF
BUYER 32
304-558-0492

VENDOR
 *709024742 800-234-4900
 NORIX GROUP INC
 1000 ATLANTIC DRIVE
 WEST CHICAGO IL 60185

SHIP TO
 WV PRISON INDUSTRIES
 617 LEON SULLIVAN WAY
 CHARLESTON, WV
 25301 304-558-2945

DATE PRINTED 09/18/2006	TERMS OF SALE	SHIP VIA	F.O.B.	FREIGHT TERMS
-----------------------------------	---------------	----------	--------	---------------

BID OPENING DATE: **10/11/2006** BID OPENING TIME **01:30PM**

LINE	QUANTITY	UOP	CAT NO.	ITEM NUMBER	UNIT PRICE	AMOUNT
<p>() BIDDER IS A RESIDENT VENDOR WHO CERTIFIES THAT, DURING THE LIFE OF THE CONTRACT, ON AVERAGE AT LEAST 75% OF THE EMPLOYEES WORKING ON THE PROJECT BEING BID ARE RESIDENTS OF WEST VIRGINIA WHO HAVE RESIDED IN THE STATE CONTINUOUSLY FOR THE TWO YEARS IMMEDIATELY PRECEDING SUBMISSION OF THIS BID;</p> <p>OR</p> <p>() BIDDER IS A NONRESIDENT VENDOR EMPLOYING A MINIMUM OF ONE HUNDRED STATE RESIDENTS OR IS A NONRESIDENT VENDOR WITH AN AFFILIATE OR SUBSIDIARY WHICH MAINTAINS ITS HEADQUARTERS OR PRINCIPAL PLACE OF BUSINESS WITHIN WEST VIRGINIA EMPLOYING A MINIMUM OF ONE HUNDRED STATE RESIDENTS WHO CERTIFIES THAT, DURING THE LIFE OF THE CONTRACT, ON AVERAGE AT LEAST 75% OF THE EMPLOYEES OR BIDDERS' AFFILIATE'S OR SUBSIDIARY'S EMPLOYEES ARE RESIDENTS OF WEST VIRGINIA WHO HAVE RESIDED IN THE STATE CONTINUOUSLY FOR THE TWO YEARS IMMEDIATELY PRECEDING SUBMISSION OF THIS BID.</p> <p>BIDDER UNDERSTANDS IF THE SECRETARY OF TAX & REVENUE DETERMINES THAT A BIDDER RECEIVING PREFERENCE HAS FAILED TO CONTINUE TO MEET THE REQUIREMENTS FOR SUCH PREFERENCE, THE SECRETARY MAY ORDER THE DIRECTOR OF PURCHASING TO: (A) RESCIND THE CONTRACT OR PURCHASE ORDER ISSUED; OR (B) ASSESS A PENALTY AGAINST SUCH BIDDER IN AN AMOUNT NOT TO EXCEED 5% OF THE BID AMOUNT AND THAT SUCH PENALTY WILL BE PAID TO THE CONTRACTING AGENCY OR DEDUCTED FROM ANY UNPAID BALANCE ON THE CONTRACT OR PURCHASE ORDER.</p> <p>BY SUBMISSION OF THIS CERTIFICATE, BIDDER AGREES TO DISCLOSE ANY REASONABLY REQUESTED INFORMATION TO THE PURCHASING DIVISION AND AUTHORIZES THE DEPARTMENT OF TAX AND REVENUE TO DISCLOSE TO THE DIRECTOR OF PURCHASING APPROPRIATE INFORMATION VERIFYING THAT</p>						

SEE REVERSE SIDE FOR TERMS AND CONDITIONS

SIGNATURE  TELEPHONE **800-234-4900** DATE **10-5-2006**

TITLE **Vice President Sales** FEIN **36-3257149** ADDRESS CHANGES TO BE NOTED ABOVE

WHEN RESPONDING TO RFQ, INSERT NAME AND ADDRESS IN SPACE ABOVE LABELED 'VENDOR'



State of West Virginia
 Department of Administration
 Purchasing Division
 2019 Washington Street East
 Post Office Box 50130
 Charleston, WV 25305-0130

Request for Quotation

RFQ NUMBER
PRI2674

PAGE
4

ADDRESS CORRESPONDENCE TO ATTENTION OF
BUYER 32
304-558-0492

VENDOR
 *709024742 800-234-4900
 NORIX GROUP INC
 1000 ATLANTIC DRIVE
 WEST CHICAGO IL 60185

SHIP TO
 WV PRISON INDUSTRIES
 617 LEON SULLIVAN WAY
 CHARLESTON, WV
 25301 304-558-2945

DATE PRINTED 09/18/2006	TERMS OF SALE	SHIP VIA	F.O.B.	FREIGHT TERMS
-----------------------------------	---------------	----------	--------	---------------

BID OPENING DATE: **10/11/2006** BID OPENING TIME **01:30PM**

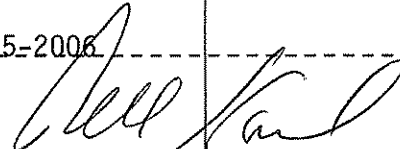
LINE	QUANTITY	UOP	CAT NO	ITEM NUMBER	UNIT PRICE	AMOUNT
<p>BIDDER HAS PAID THE REQUIRED BUSINESS TAXES, PROVIDED THAT SUCH INFORMATION DOES NOT CONTAIN THE AMOUNTS OF TAXES PAID NOR ANY OTHER INFORMATION DEEMED BY THE TAX COMMISSIONER TO BE CONFIDENTIAL.</p> <p>UNDER PENALTY OF LAW FOR FALSE SWEARING (WEST VIRGINIA CODE 61-5-3), BIDDER HEREBY CERTIFIES THAT THIS CERTIFICATE IS TRUE AND ACCURATE IN ALL RESPECTS; AND THAT IF A CONTRACT IS ISSUED TO BIDDER AND IF ANYTHING CONTAINED WITHIN THIS CERTIFICATE CHANGES DURING THE TERM OF THE CONTRACT, BIDDER WILL NOTIFY THE PURCHASING DIVISION IN WRITING IMMEDIATELY.</p> <p>BIDDER: <u>Norix Group, Inc.</u></p> <p>DATE: <u>10-5-2006</u></p> <p>SIGNED: </p> <p>TITLE: <u>Vice President Sales</u></p> <p>* CHECK ANY COMBINATION OF PREFERENCE CONSIDERATION(S) IN EITHER "A" OR "B", OR BOTH "A" AND "B" WHICH YOU ARE ENTITLED TO RECEIVE. YOU MAY REQUEST UP TO THE MAXIMUM 5% PREFERENCE FOR BOTH "A" AND "B". (REV. 12/00)</p> <p>NOTICE</p> <p>A SIGNED BID MUST BE SUBMITTED TO:</p> <p>DEPARTMENT OF ADMINISTRATION PURCHASING DIVISION</p>						

SIGNATURE 		SEE REVERSE SIDE FOR TERMS AND CONDITIONS	
TITLE Vice President Sales	FEIN 36-3257149	TELEPHONE 800-234-4900	DATE 10-5-2006

ADDRESS CHANGES TO BE NOTED ABOVE

WHEN RESPONDING TO RFQ, INSERT NAME AND ADDRESS IN SPACE ABOVE LABELED 'VENDOR'



State of West Virginia
 Department of Administration
 Purchasing Division
 2019 Washington Street East
 Post Office Box 50130
 Charleston, WV 25305-0130

Request for Quotation

RFQ NUMBER
PRI2674

PAGE
6

ADDRESS CORRESPONDENCE TO ATTENTION OF
BUYER 32
304-558-0492

VENDOR
 *709024742 800-234-4900
 NORIX GROUP INC
 1000 ATLANTIC DRIVE
 WEST CHICAGO IL 60185

SHIP TO
 WV PRISON INDUSTRIES
 617 LEON SULLIVAN WAY
 CHARLESTON, WV
 25301 304-558-2945

DATE PRINTED 09/18/2006	TERMS OF SALE	SHIP VIA	F.O.B.	FREIGHT TERMS
-----------------------------------	---------------	----------	--------	---------------

BID OPENING DATE: **10/11/2006** BID OPENING TIME **01:30PM**

LINE	QUANTITY	UOP	CAT NO.	ITEM NUMBER	UNIT PRICE	AMOUNT
***** THIS IS THE END OF RFQ PRI2674 ***** TOTAL:						<u>\$164,965.34</u>

SEE REVERSE SIDE FOR TERMS AND CONDITIONS

SIGNATURE 	TELEPHONE 800-234-4900	DATE 10-5-2006
TITLE Vice President Sales	FEIN 36-3257149	ADDRESS CHANGES TO BE NOTED ABOVE

WHEN RESPONDING TO RFQ, INSERT NAME AND ADDRESS IN SPACE ABOVE LABELED 'VENDOR'

PRI2674 - BID FORM - STORAGE BOXES, TABLES, & CHAIRS - BID OPENING DATE: 10/11/2006, 1:30 PM					
Item#	Description	Brand & Model # or Equal	Unit Bid Price	Estimated Usage	Extended Bid Price
1	Tank Storage Box	NORIX / PB200	\$	480	\$
2	Tank Storage Box Lids	NORIX / PBL400	\$	480	\$
3	Tank Storage Box	NORIX / PB350 XL	\$	20	\$
4	Tank Storage Box Lids	NORIX / PB402	\$	20	\$
5	Slammer Tables Laminate Game Top	NORIX / XB4242GT	\$	40	\$
6	Slammer Tables Pearl Sand Lam. Top	NORIX / XB4242PT	\$	88	\$
7	Integra Armless Chairs - Buff	NORIX / C110	\$	78	\$
8	Integra Armless Chairs - Plum	NORIX / C110	\$	78	\$
9	Integra Armless Chairs - Teal	NORIX / C110	\$	95	\$
10	Integra Armless Chairs - Fog Grey	NORIX / C110	\$	95	\$
11	Integra Armless Chairs - Blue Grey	NORIX / C110	\$	95	\$
12	Integra Armless Chairs - Slate Blue	NORIX / C110	\$	95	\$
				Total	\$

Bidder Information:

Name: _____

Company name: _____

Address: _____

Phone#: _____

Fax#: _____

Email Address: _____

SEE ADDENDUM # 1

A F F I D A V I T

West Virginia Code §5A-3-10a states:

No contract or renewal of any contract may be awarded by the state or any of its political subdivisions to any vendor or prospective vendor when the vendor or prospective vendor or a related party to the vendor or prospective vendor is a debtor and the debt owned is an amount greater than one thousand dollars in the aggregate.

DEFINITIONS:

"Debt" means any assessment, premium, penalty, fine, tax or other amount of money owed to the state or any of its political subdivisions because of a judgment, fine, permit violation, license assessment, defaulted workers' compensation premium, penalty or other assessment presently delinquent or due and required to be paid to the state or any of its political subdivisions, including any interest or additional penalties accrued thereon.

"Debtor" means any individual, corporation, partnership, association, limited liability company or any other form or business association owing a debt to the state or any of its political subdivisions.

"Political subdivision" means any county commission; municipality; county board of education; any instrumentality established by a county or municipality; any separate corporation or instrumentality established by one or more counties or municipalities, as permitted by law; or any public body charged by law with the performance of a government function or whose jurisdiction is coextensive with one or more counties or municipalities.

"Related party" means a party, whether an individual, corporation, partnership, association, limited liability company or any other form or business association or other entity whatsoever, related to any vendor by blood, marriage, ownership or contract through which the party has a relationship of ownership or other interest with the vendor so that the party will actually or by effect receive or control a portion of the benefit, profit or other consideration from performance of a vendor contract with the party receiving an amount that meets or exceeds five percent of the total contract amount.

EXCEPTION:

The prohibition of this section does not apply where a vendor has contested any tax administered pursuant to chapter eleven of this code, workers' compensation premium, permit fee or environmental fee or assessment and the matter has not become final or where the vendor has entered into a payment plan or agreement and the vendor is not in default of any of the provisions of such plan or agreement.

LICENSING:

The vendor must be licensed in accordance with any and all state requirements to do business with the state of West Virginia.

CONFIDENTIALITY:

The vendor agrees that he or she will not disclose to anyone, directly or indirectly, any such personally identifiable information or other confidential information gained from the agency, unless the individual who is the subject of the information consents to the disclosure in writing or the disclosure is made pursuant to the agency's policies, procedures and rules. Vendors should visit www.state.wv.us/admin/purchase/privacy for the Notice of Agency Confidentiality Policies.

Under penalty of law for false swearing (West Virginia Code, §61-5-3), it is hereby certified that the vendor acknowledges the information in this said affidavit and are in compliance with the requirements as stated.

Vendor's Name: Norix Group, Inc.

Authorized Signature: _____

Date: 10-5-2006



State of West Virginia
 Department of Administration
 Purchasing Division
 2019 Washington Street East
 Post Office Box 50130
 Charleston, WV 25305-0130

Request for Quotation

RFQ NUMBER
PRI2674

PAGE
1

ADDRESS CORRESPONDENCE TO ATTENTION OF:
BUYER 32
304-558-0492

***709024742 800-234-4900**
NORIX GROUP INC
1000 ATLANTIC DRIVE
WEST CHICAGO IL 60185

WV PRISON INDUSTRIES
617 LEON SULLIVAN WAY
CHARLESTON, WV
25301 304-558-2945

DATE PRINTED 09/21/2006	TERMS OF SALE	SHIP VIA	F.O.B.	FREIGHT TERMS
-----------------------------------	---------------	----------	--------	---------------

BID OPENING DATE: **10/11/2006** BID OPENING TIME **01:30PM**

LINE	QUANTITY	UOP	CAT. NO.	ITEM NUMBER	UNIT PRICE	AMOUNT
ADDENDUM# 01						
THIS ADDENDUM IS ISSUED TO ADD TO THE ORIGINAL QUANTITY, MODEL NUMBERS, & LOCATION OF DELIVERY.						
CLERIFICATION: DELIVERY OF ITEMS 1-12 SHALL BE DELIVERED TO THE HUTTONSVILLE CORRECTIONAL CENTER STATE RT. HIGHWAY 250, HUTTONSVILLE, WV 26273. ITEM NUMBERS 13 THROUGH 17 WILL BE DELIVERED TO THE LAKIN CORRECTIONAL CENTER, 11264 OHIO RIVER ROAD, WEST COLUMBIA, WV 25287.						
ATTACHMENTS:						
<ol style="list-style-type: none"> 1. REVISED BID FORM 2. ADDENDUM ACKNOWLEDGEMENT 						

SIGNATURE  TELEPHONE **800-234-4900** DATE **10-5-2006**

TITLE **Vice President Sales** FEIN **36-3257149** ADDRESS CHANGES TO BE NOTED ABOVE

WHEN RESPONDING TO RFQ, INSERT NAME AND ADDRESS IN SPACE ABOVE LABELED 'VENDOR'

PRI2674 - (REVISED) BID FORM - STORAGE BOXES, TABLES, & CHAIRS - BID OPENING DATE: 10/11/2006, 1:30 PM

Item#	Description	Brand & Model # or Equal	Unit Bid Price	Estimated Usage	Extended Bid Price
1	Tank Storage Box	NORIX / PB200	\$ 41.54	480	\$ 19,939.20
2	Tank Storage Box Lids	NORIX / PBL400	\$ 22.61	480	\$ 10,852.80
3	Tank Storage Box	NORIX / PB350 XL	\$ 78.77	20	\$ 1575.40
4	Tank Storage Box Lids	NORIX / PB402	\$ 35.28	20	\$ 705.60
5	Slammer Tables Laminate Game Top	NORIX / XB4242GT	\$ 550.85	40	\$ 22,034.00
6	Slammer Tables Pearl Sand Lam. Top	NORIX / XB4242PT	\$ 485.37	88	\$ 42,712.56
7	Integra Armless Chairs - Buff	NORIX / C110	\$ 41.52	78	\$ 3,238.56
8	Integra Armless Chairs - Plum	NORIX / C110	\$ 41.52	78	\$ 3,238.56
9	Integra Armless Chairs - Teal	NORIX / C110	\$ 41.52	95	\$ 3,944.40
10	Integra Armless Chairs - Fog Grey	NORIX / C110	\$ 41.52	95	\$ 3,944.40
11	Integra Armless Chairs - Blue Grey	NORIX / C110	\$ 41.52	95	\$ 3,944.40
12	Integra Armless Chairs - Slate Blue	NORIX / C110	\$ 41.52	95	\$ 3,944.40
13	Integra Armless Chairs - Buff	NORIX / C110	\$ 41.52	212	\$ 8,802.24
14	Integra Arm Chairs - Buff	NORIX / C120	\$ 56.44	44	\$ 2,483.36
15	Mega-Max Seats - Teal	NORIX / C170	\$ 240.06	11	\$ 2,640.66
16	Mega-Max Seats - Buff	NORIX / C170	\$ 240.06	10	\$ 2,400.60
17	42X42 Sq. Leg Table w/Game Top - Black Slammer Stone Edge	NORIX / LB4242GT	\$ 476.07	60	\$ 28,564.20
				Total	\$164,965.34

Bidder Information:

Name: Bill Karl / Jessica Earley

Company name: Norix Group, Inc.

Address: 1000 Atlantic Drive
West Chicago, IL 60185

Phone#: 800-234-4900

Fax#: (630) 231-4343

Email Address: furniture@norix.com

Property Box (a.k.a. Tank Box)

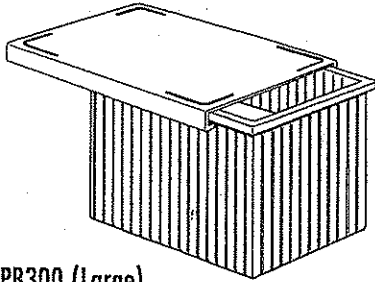

Model #: PB300 (Large)

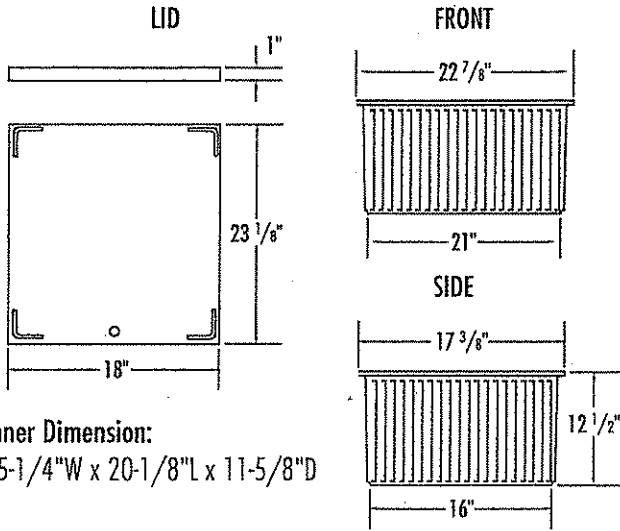

Inner Dimension:
15-1/4"W x 20-1/8"L x 11-5/8"D

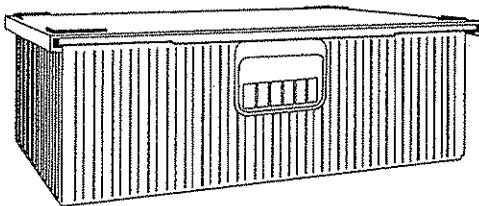

Model #: PB350 (Extra Large)

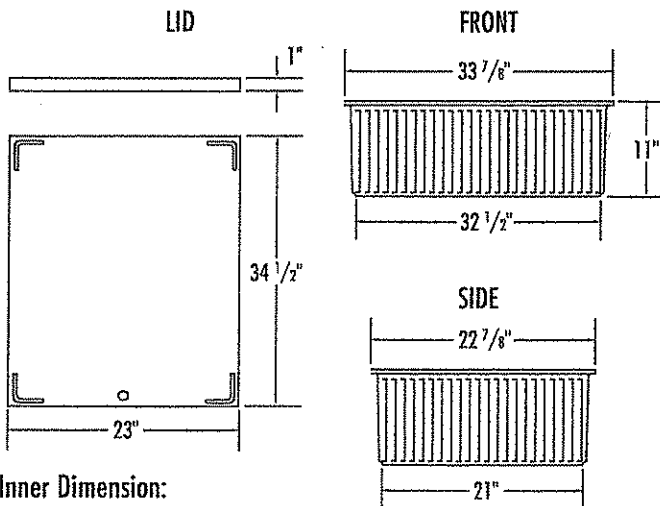

Inner Dimension:
32"W x 20-1/2"L x 10-5/8"D

Property Box (a.k.a. Tank Box)

Property storage boxes for inmate records and/or personal possessions. Designed and engineered for institutional durability. Suitable for continuous daily use in a correctional environment.

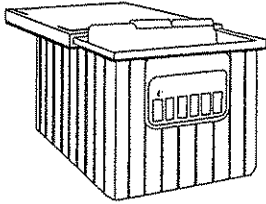

Model #: PB150 (Legal/Letter)

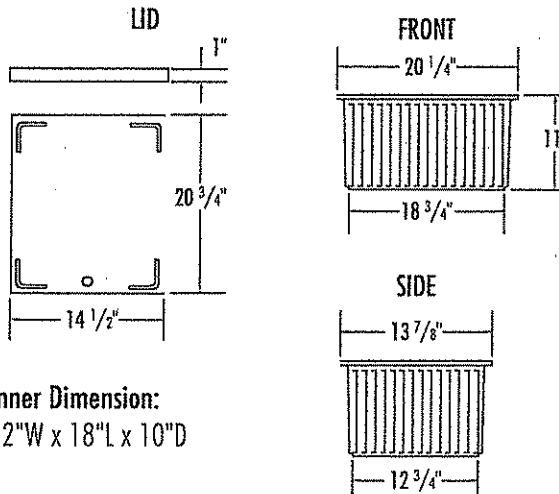

Inner Dimension:
 12"W x 18"L x 10"D

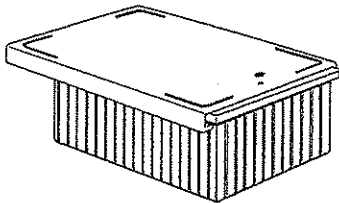

Model #: PB200 (Standard)

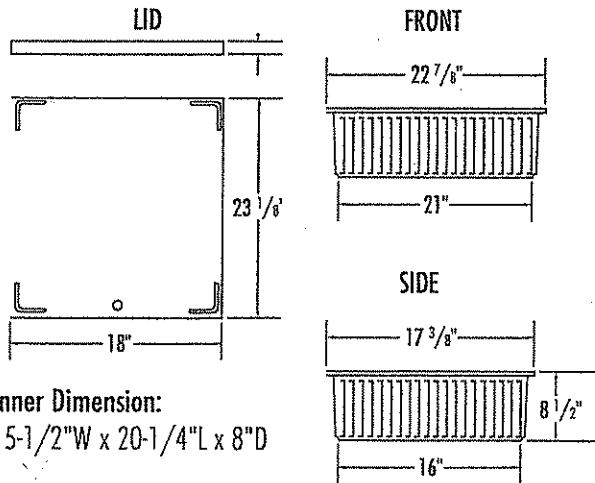

Inner Dimension:
 15-1/2"W x 20-1/4"L x 8"D

Fabrication:

Full height molded-in vertical ribs every 1-1/4". 1/2" x 7/8" top flange provides maximum strength and rigidity. Capable of nesting for stable stacking.

Material:

Injection molded from structural polyethylene. 100% recyclable.

Flammability:

Certified to pass the following flammability standards:

- State of California, Technical Bulletin No. 133, Flammability Test Procedure for Seating Furniture for Use in Public Occupancies.

Quality & Testing Standards, conforms to:

- Minimum sustained static load of 3000 lbs. for four hours.

Color:

Grey.

Weight:

Box:

- PB150 (Legal/Letter): 9.5 lbs.
- PB200 (Standard): 9 lbs.
- PB300 (Large): 12 lbs.
- PB350 (Extra Large): 22.5 lbs.

Lid:

- PBL401: 3.5 lbs.
- PBL400: 4 lbs.
- PBL400: 4 lbs.
- PBL402: 8 lbs.

Options:

Sliding lid. Padlock. Under bunk rail sets.

Assembly:

None required.

Installation:

None required.

Warranty:

2 year limited replacement warranty.

Maintenance:

Easily cleaned with a damp cloth and mild soap solution.

Filing System:

- 12600 Institutional Furniture
- 11197 Correctional Furniture

Continued on back.

Slammer Table

Heavy duty durable, tamper-resistant "X" base style. Engineered and suitable for continuous use in an institutional or correctional environment.

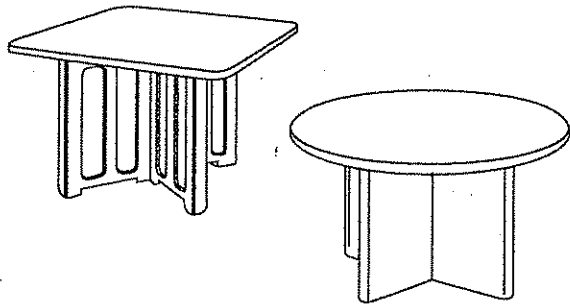

- Model #:** XB3636PT (36"x36")
 XB3636GT (36"x36" Game Top)
 XB4242PT (42"x42")
 XB4242GT (42"x42" Game Top)
 XB3600PT (36" dia.)
 XXB3600GT (36" dia. Game Top)
 XB4200PT (42" dia.)
 XB4200GT (42" dia. Game Top)
 XB4800PT (48" dia.)
 XB4800GT (48" dia. Game Top)

TOP

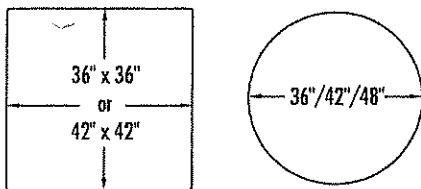

FRONT

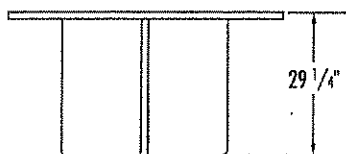
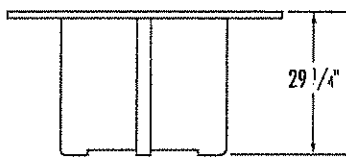

Fabrication:

Base: Two interlocking base panels.

Top: Selected material permanently bonded to a core of 45 lb. density particle board with embedded T-nuts for securing top to base.

Material:

Laminate Base Panels: 1-1/8" thick 45 lb. density particle board, sandwiched between 1/8" thick hardboard and faced both sides with .050" thick high pressure laminate and banded on three exposed edges with heavy duty T-molding that is glued and steel pinned every four inches. An intermediate mounting plate joins the base to the top.

Rotationally Molded Base: Specially formulated fire retardant high impact polyethylene with ultraviolet light stabilizers (to reduce fading). Openings sealed by the top allow the base to be weighted on-site with clean, dry sand (not included).

Laminate Top: Decorative high pressure laminate sealed with a specially formulated highly durable Slammer Stone edge. Edge is radiused for safety and pressure fused to the top rendering it permanently non-removable and highly sanitary. 1-1/2" thick edge profile.

Nu-Stone® Top: Specially formulated fiberglass filled polyester composite, compression molded under 2,000 p.s.i. pressure to create a seamless, one-piece top and edge surface for superior impact resistance and durability. 1-1/2" thick edge profile (42" round and square only).

Stainless Steel Quietcore® Top: Durable 18 gauge stainless steel top surface wrapped around sound deadening particle board core. 1-1/4" edge profile (42" round only).

Color:

Base: Black Slate Laminate or Black Polyethylene.

Laminate Top: Wilsonart Pearl Sand #4604-60 with black Slammer Stone edge.

Nu-Stone® Top: GraniteStone or PebbleStone.

Stainless Steel Top: #4 finish.

Weight:

Varies on model. Contact manufacturer.

Options:

1-1/4" thick laminate top with black vinyl T-mold edge.

Game tops (GT): Checkerboard available on Nu-Stone® and Stainless Steel tops. Checkerboard / backgammon / solitaire available on laminate tops.

Assembly:

Assembly required

Installation:

Refer to manufacturer's instructions for securing top to base.

Warranty:

2 year limited replacement warranty.

Maintenance:

Easily cleaned with a damp cloth.

Filing System:

12600 Institutional Furniture

11197 Correctional Furniture

Integra® Armless Chair

Multi-use stackable armless chair. Engineered and proven suitable for continuous daily use in an institutional environment. (Note: For safety reasons, chairs with open backs or arms, patio style, or residential quality chairs should not be used for this requirement). Compatible style, color, construction, material, functionality and durability with arm chairs, lounge chairs and tables provided by Norix.

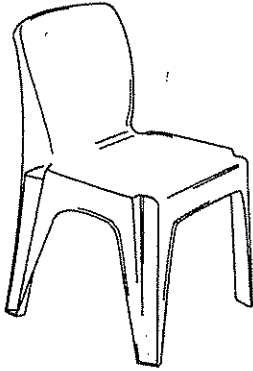

Model #: C110

TOP

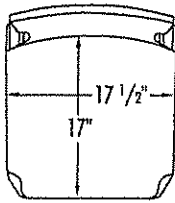

FRONT

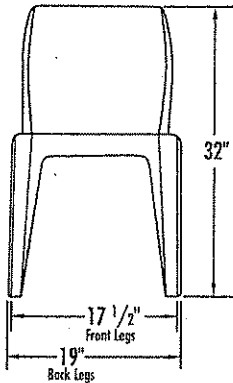

SIDE

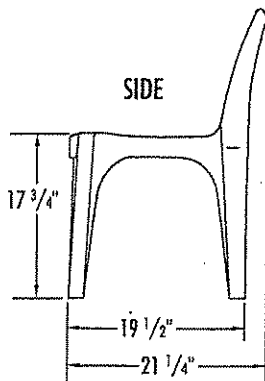

Fabrication:

One-piece injection molded, without steel or wood components. 1-1/2" deep "X" rib on the underside of the seat, connecting legs diagonally for superior strength. Honeycomb reinforcing rib cells.

Material:

High impact grade copolymer polypropylene with FRPP5 Fire Retardant. Chemically resistant to acetone, alcohol, blood, vinegar, urine, feces, salt solution and chlorine solution.

Flammability:

Certified to pass the following flammability standards:

- State of California, Technical Bulletin No. 133, Flammability Test Procedure for Seating Furniture for Use in Public Occupancies.
- Federal Aviation Administration Test 25.853 A & B, Appendix F, Part 1, 60 second gas burner ignition, material self-extinguishing & 12 second gas burner ignition, material self-extinguishing. (Note: Flammability tests reflect standardized laboratory test procedures and may not reflect results in actual fire conditions).

Quality & Testing Standards, conforms to:

- ISO 9001-1987: Quality certified manufacturer.
- ASTM F1561-94, Parts A & B: Standard Performance Test for Plastic Chairs.
- Furniture Industry Research Association: Grade 5 - Severe Contract Applications, 200,000+ cycles.

Color:

Buff, Fog Grey, Blue Grey, Plum, Teal, Slate Blue.

Stacking:

15 chairs in 83".

Weight:

7.1 lbs.

Options:

3 wheel dolly.

Assembly:

None required.

Installation:

None required.

Warranty:

2 year limited replacement warranty.

Maintenance:

Easily cleaned with a damp cloth and a mild soap solution.

Filing System:

- 12600 Institutional Furniture
- 11197 Correctional Furniture

Integra[®] Arm Chair

Multi-use stackable arm chair. Self-ganging without additional components. Engineered and proven suitable for continuous daily use in an institutional environment. (Note: For safety reasons chairs with open backs or arms, patio style, or residential quality chairs should not be used for this requirement). Compatible style, color, construction, material, functionality and durability with armless chairs, lounge chairs and tables provided by Norrix.

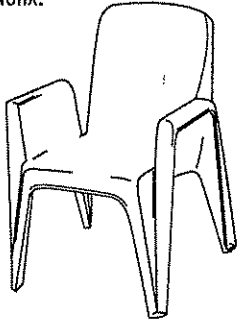

Model #: C120

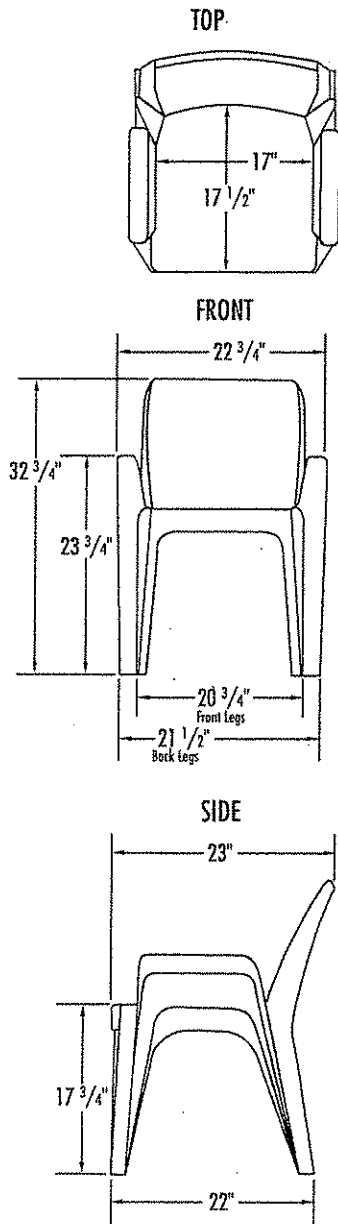

Fabrication:

One-piece injection molded, without steel or wood components. 1-1/2" deep "X" rib on the underside of the seat, connecting legs diagonally for superior strength. Honeycomb reinforcing rib cells.

Material:

High impact grade copolymer polypropylene with FRPP5 Fire Retardant. Chemically resistant to acetone, alcohol, blood, vinegar, urine, feces, salt solution and chlorine solution.

Flammability:

Certified to pass the following flammability standards:

- State of California, Technical Bulletin No. 133, Flammability Test Procedure for Seating Furniture for Use in Public Occupancies.
- Federal Aviation Administration Test 25.853 A & B, Appendix F, Part 1, 60 second gas burner ignition, material self-extinguishing & 12 second gas burner ignition, material self-extinguishing. (Note: Flammability tests reflect standardized laboratory test procedures and may not reflect results in actual fire conditions).

Quality & Testing Standards, conforms to:

- ISO 9001-1987: Quality certified manufacturer.
- ASTM F1561-94, Parts A & B: Standard Performance Test for Plastic Chairs.
- Furniture Industry Research Association: Grade 5 - Severe Contract Applications, 200,000+ cycles.

Color:

Buff, Fog Grey, Blue Grey, Plum, Teal, Slate Blue.

Stacking:

15 chairs in 77".

Weight:

9.7 lbs.

Options:

3 wheel dolly.

Assembly:

None required.

Installation:

None required.

Warranty:

2 year limited replacement warranty.

Maintenance:

Easily cleaned with a damp cloth and a mild soap solution.

Filing System:

- 12600 Institutional Furniture
- 11197 Correctional Furniture

Mega-Max[®] Sectional Lounge Chair

Sectional lounge chair system. Ganging and ballasting capability assures these chairs can be reconfigured as future needs require. Engineered and proven suitable for continuous daily use in an institutional environment. Ergonomically designed for comfort without the use of foam for cushioning.

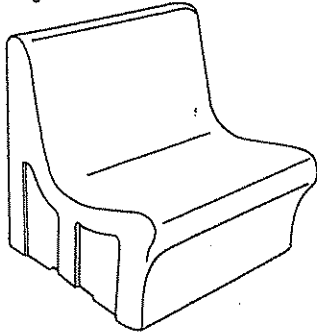

Model #: C170

TOP

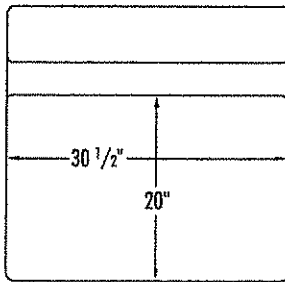

FRONT

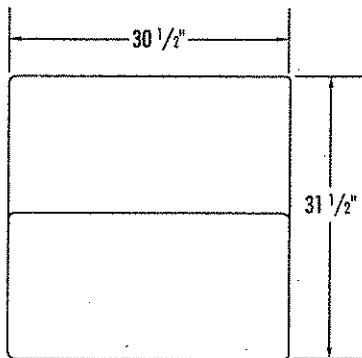

SIDE

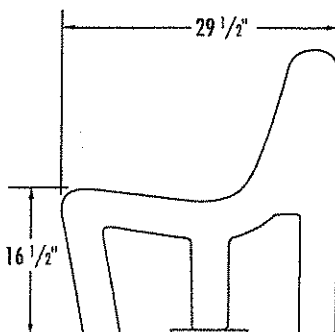

Fabrication:

One-piece rotationally molded. Full perimeter floor support to facilitate ease of cleaning and to prevent concealment of contraband. Standard with sealed bottom. Molded-in steel threaded inserts for ganging side-to-side, back-to-back or bolt-down applications.

Material:

Specially formulated fire retardant, high impact polyethylene with ultraviolet light stabilizers (to reduce fading). Chemically resistant to blood, vinegar, urine, feces, salt solution, and chlorine solution.

Flammability:

Certified to pass the following flammability standards:

- State of California, Technical Bulletin No. 133, Flammability Test Procedure for Seating Furniture for Use in Public Occupancies.

Quality & Testing Standards, conforms to:

- ANSI/BIFMA X5.1 2002 General Purpose Office Chairs.

Color:

Buff, Fog Grey, Blue Grey, Plum, Teal, Slate Blue.

Weight:

36 lbs.

Options:

Polyethylene ganging plates, polyethylene ballasting bags (user provides and installs clean, dry sand), stainless steel plates for bolt-down application.

Assembly:

None required.

Installation:

Required for bolt-down plates, ganging plates, ballast, and ballast plate, if used.

Warranty:

2 year limited replacement warranty.

Maintenance:

Easily cleaned with a damp cloth and a mild soap solution.

Filing System:

12600 Institutional Furniture

11197 Correctional Furniture

BOTTOM (Ganging Option)

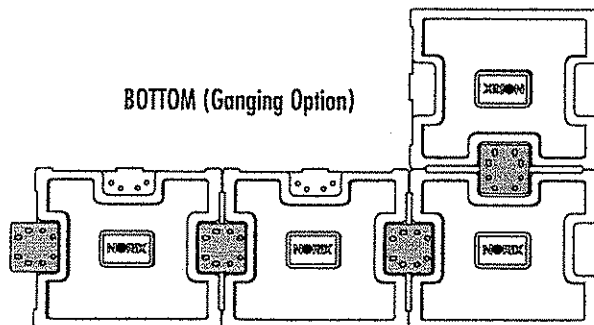

Leg Style Table

Heavy duty leg style tables built for stability and ADA requirements. Engineered and suitable for continuous daily use in an institutional environment.

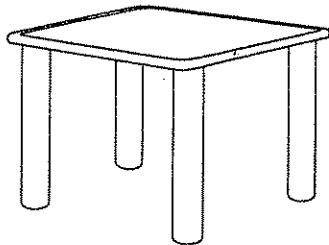

TOP

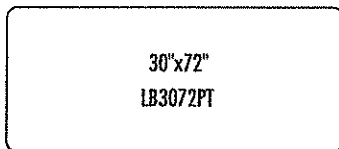
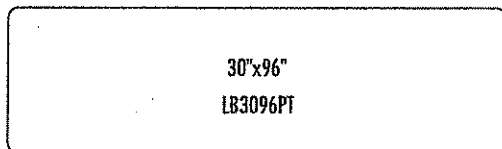
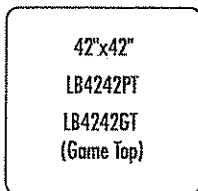
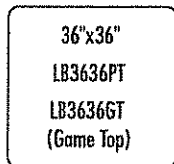
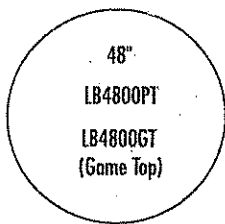

SIDE

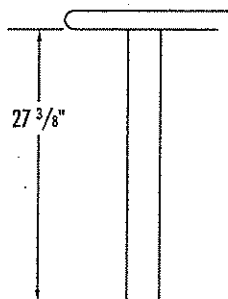

Fabrication:

Legs: Steel tubing welded to steel plate for attaching top. Bottom of leg sealed by means of a fully welded inset threaded to accommodate a non-removable adjustable leveling glide.

Top: Permanently bonded to a core of 45 lb. density particle board with permanently embedded T-nuts for securing top to base with a metal-to-metal connection.

Material:

Legs: 4" diameter, 14 gauge wall thickness steel tubing welded to a 6" x 6" x 1/4" steel plate.

Laminate Top: Decorative high pressure laminate sealed with a specially formulated highly durable Slammer Stone edge. Edge is radiused for safety and pressure fused to the top rendering it permanently non-removable and highly sanitary. 1-1/2" thick edge profile.

Nu-Stone® Top: Specially formulated fiberglass filled polyester composite, compression molded under 2,000 p.s.i. pressure to create a seamless, one-piece top and edge surface for superior impact resistance and durability.

Color:

Base: Black textured powder coat.

Laminate Top: Wilsonart 4604-60 Pearl Sand with black Slammer Stone edge.

Nu-Stone® Top: GraniteStone or PebbleStone.

Weight:

Varies on model. Contact manufacturer.

Options:

Bolt-down configuration.

Game tops (GT): Checkerboard available on Nu-Stone® tops.

Checkerboard / backgammon / solitaire available on laminate tops.

1-1/4" laminate top with black vinyl T-mold edge.

Assembly:

Refer to manufacturers instructions for securing top to base.

Installation:

None required.

Warranty:

2 year limited replacement warranty.

Maintenance:

Easily cleaned with a damp cloth and mild soap solution.

Filing System:

12600 Institutional Furniture

11197 Correctional Furniture