



State of West Virginia
 Department of Administration
 Purchasing Division
 2019 Washington Street East
 Post Office Box 50130
 Charleston, WV 25305-0130

Request for Quotation

RFQ NUMBER
 PKG076200

PAGE
 1

ADDRESS CORRESPONDENCE TO ATTENTION OF
 KRISTA FERRELL
 304-558-2596

RFQ COPY
 TYPE NAME/ADDRESS HERE
 Nilfisk-Advance, Inc.
 14600 21st Avenue, N
 Plymouth, MN 55447

DEPARTMENT OF ADMINISTRATION
 GENERAL SERVICES DIVISION
 BUILDING 13 PARKING GARAGE
 GREENBRIER ST & PIEDMONT RD
 CHARLESTON, WV
 25301 304-558-2317

DATE PRINTED: 02/13/2007	TERMS OF SALE	SHIP VIA	FO.B	FREIGHT TERMS
ID OPENING DATE: 03/08/2007	BID OPENING TIME 01:30PM			

LINE	QUANTITY	UOP	CAT NO	ITEM NUMBER	UNIT PRICE	AMOUNT
001	1	EA		765-77	\$31,437. ⁸⁵	\$31,437. ⁸⁵
TENNANT M20 INTEGRATED SCRUBBER-SWEEPER, OR EQUAL AMERICAN-LINCOLN MODEL SC7740LP, RIDER SWEEPER/SCRUBBER REQUEST FOR QUOTATION THE WEST VIRGINIA PURCHASING DIVISION FOR THE AGENCY, THE WEST VIRGINIA DEPARTMENT OF ADMINISTRATION'S GENERAL SERVICE DIVISION, IS SOLICITING BIDS TO PROVIDE THE AGENCY WITH (1) TENNANT MODEL #M20 INTEGRATED SCRUBBER-SWEEPER (OR EQUIVALENT) PER THE ATTACHED SPECIFICATIONS. TECHNICAL QUESTIONS MUST BE SUBMITTED IN WRITING TO KRISTA FERRELL IN THE WEST VIRGINIA PURCHASING DIVISION VIA FAX AT 304-558-4115, VIA EMAIL AT KFERRELL@WVADMIN.GOV OR VIA MAIL AT THE ADDRESS SHOWN IN THE BODY OF THIS RFQ. DEADLINE FOR TECHNICAL QUESTIONS IS FEBRUARY 27, 2007 AT 5PM. ALL TECHNICAL QUESTIONS RECEIVED, IF ANY, WILL BE ANSWERED BY ADDENDUM AFTER THE DEADLINE. QUESTIONS CONCERNING THE ACTUAL SUBMISSION OF A VENDOR'S BID MAY BE SUBMITTED AT ANY TIME PRIOR TO THE BID OPENING DATE AND IN ANY FORMAT. BANKRUPTCY: IN THE EVENT THE VENDOR/CONTRACTOR FILES FOR BANKRUPTCY PROTECTION, THIS CONTRACT IS AUTOMATI- CALLY NULL AND VOID, AND IS TERMINATED WITHOUT FURTHER ORDER. THE MODEL/BRAND/SPECIFICATIONS NAMED HEREIN ESTABLISH THE ACCEPTABLE LEVEL OF QUALITY ONLY AND ARE NOT						

SEE REVERSE SIDE FOR TERMS AND CONDITIONS

SIGNATURE *[Signature]* TELEPHONE 888-742-8470 DATE 3-14-07
 Govt. Contracts Manager FEIN 41-0116040 ADDRESS CHANGES TO BE NOTED ABOVE

WHEN RESPONDING TO RFQ, INSERT NAME AND ADDRESS IN SPACE ABOVE LABELED 'VENDOR'



State of West Virginia
 Department of Administration
 Purchasing Division
 2019 Washington Street East
 Post Office Box 50130
 Charleston, WV 25305-0130

Request for Quotation

RFQ NUMBER:
 PKG076200

PAGE:
 2

ADDRESS CORRESPONDENCE TO ATTENTION OF:
 KRISTA FERRELL
 304-558-2596

RFQ COPY
 TYPE NAME/ADDRESS HERE
 Nilfisk-Advance, Inc.
 14600 21st Avenue, N
 Plymouth, MN 55447

DEPARTMENT OF ADMINISTRATION
 GENERAL SERVICES DIVISION
 BUILDING 13 PARKING GARAGE
 GREENBRIER ST & PIEDMONT RD
 CHARLESTON, WV
 25301 304-558-2317

DATE PRINTED	TERMS OF SALE	SHIP VIA	F.O.B.	FREIGHT TERMS
02/13/2007				
ID OPENING DATE: 03/08/2007		BID OPENING TIME 01:30PM		

LINE	QUANTITY	UOP	CAT NO	ITEM NUMBER	UNIT PRICE	AMOUNT
				NOT APPLICABLE		N/A
<p>INTENDED TO REFLECT A PREFERENCE OR FAVOR ANY PARTICULAR BRAND OR VENDOR. VENDORS WHO ARE BIDDING ALTERNATES SHOULD SO STATE AND INCLUDE PERTINENT LITERATURE AND SPECIFICATIONS. FAILURE TO PROVIDE INFORMATION FOR ANY ALTERNATES MAY BE GROUNDS FOR REJECTION OF THE BID. THE STATE RESERVES THE RIGHT TO WAIVE MINOR IRREGULARITIES IN BIDS OR SPECIFICATIONS IN ACCORDANCE WITH SECTION 148-1-4(F) OF THE WEST VIRGINIA LEGISLATIVE RULES AND REGULATIONS.</p> <p>VENDOR PREFERENCE CERTIFICATE</p> <p>CERTIFICATION AND APPLICATION* IS HEREBY MADE FOR PREFERENCE IN ACCORDANCE WITH WEST VIRGINIA CODE, 5A-3-37 (DOES NOT APPLY TO CONSTRUCTION CONTRACTS).</p> <p>A. APPLICATION IS MADE FOR 2.5% PREFERENCE FOR THE REASON CHECKED:</p> <p>() BIDDER IS AN INDIVIDUAL RESIDENT VENDOR AND HAS RESIDED CONTINUOUSLY IN WEST VIRGINIA FOR FOUR (4) YEARS IMMEDIATELY PRECEDING THE DATE OF THIS CERTIFICATION; OR</p> <p>() BIDDER IS A PARTNERSHIP, ASSOCIATION OR CORPORATION RESIDENT VENDOR AND HAS MAINTAINED ITS HEAD-QUARTERS OR PRINCIPAL PLACE OF BUSINESS CONTINUOUSLY IN WEST VIRGINIA FOR FOUR (4) YEARS IMMEDIATELY PRECEDING THE DATE OF THIS CERTIFICATION; OR 80% OF THE OWNERSHIP INTEREST OF BIDDER IS HELD BY ANOTHER INDIVIDUAL, PARTNERSHIP, ASSOCIATION OR CORPORATION RESIDENT VENDOR WHO HAS MAINTAINED ITS HEADQUARTERS OR PRINCIPAL PLACE OF BUSINESS CONTINUOUSLY IN WEST VIRGINIA FOR FOUR (4) YEARS IMMEDIATELY PRECEDING THE DATE OF THIS CERTIFICATION; OR</p>						

SEE REVERSE SIDE FOR TERMS AND CONDITIONS

SIGNATURE: *[Signature]* TELEPHONE: 888-742-8470 DATE: 3-14-07
 FILE: Govt. Contracts Manager FEIN: 41-0116040 ADDRESS CHANGES TO BE NOTED ABOVE

WHEN RESPONDING TO RFQ, INSERT NAME AND ADDRESS IN SPACE ABOVE LABELED 'VENDOR'



State of West Virginia
 Department of Administration
 Purchasing Division
 2019 Washington Street East
 Post Office Box 50130
 Charleston, WV 25305-0130

Request for Quotation

RFQ NUMBER
 PKG076200

PAGE
 3

ADDRESS CORRESPONDENCE TO ATTENTION OF
 KRISTA FERRELL
 304-558-2596

RFQ COPY
 TYPE NAME/ADDRESS HERE
 Nilfisk-Advance, Inc.
 14600 21st Avenue, N
 Plymouth, MN 55447

DEPARTMENT OF ADMINISTRATION
 GENERAL SERVICES DIVISION
 BUILDING 13 PARKING GARAGE
 GREENBRIER ST & PIEDMONT RD
 CHARLESTON, WV
 25301 304-558-2317

DATE PRINTED	TERMS OF SALE	SHIP VIA	F.O.B.	FREIGHT TERMS
02/13/2007				

BID OPENING DATE: 03/08/2007 BID OPENING TIME 01:30PM

LINE	QUANTITY	UOP	CAT NO	ITEM NUMBER	UNIT PRICE	AMOUNT	
				= NOT APPLICABLE =			
	<p>() BIDDER IS A CORPORATION NONRESIDENT VENDOR WHICH HAS AN AFFILIATE OR SUBSIDIARY WHICH EMPLOYS A MINIMUM OF ONE HUNDRED STATE RESIDENTS AND WHICH HAS MAINTAINED ITS HEADQUARTERS OR PRINCIPAL PLACE OF BUSINESS WITHIN WEST VIRGINIA CONTINUOUSLY FOR THE FOUR (4) YEARS IMMEDIATELY PRECEDING THE DATE OF THIS CERTIFICATION.</p> <p>B. APPLICATION IS MADE FOR 2.5% PREFERENCE FOR THE REASON CHECKED:</p> <p>() BIDDER IS A RESIDENT VENDOR WHO CERTIFIES THAT, DURING THE LIFE OF THE CONTRACT, ON AVERAGE AT LEAST 75% OF THE EMPLOYEES WORKING ON THE PROJECT BEING BID ARE RESIDENTS OF WEST VIRGINIA WHO HAVE RESIDED IN THE STATE CONTINUOUSLY FOR THE TWO YEARS IMMEDIATELY PRECEDING SUBMISSION OF THIS BID;</p> <p>OR</p> <p>() BIDDER IS A NONRESIDENT VENDOR EMPLOYING A MINIMUM OF ONE HUNDRED STATE RESIDENTS OR IS A NONRESIDENT VENDOR WITH AN AFFILIATE OR SUBSIDIARY WHICH MAINTAINS ITS HEADQUARTERS OR PRINCIPAL PLACE OF BUSINESS WITHIN WEST VIRGINIA EMPLOYING A MINIMUM OF ONE HUNDRED STATE RESIDENTS WHO CERTIFIES THAT, DURING THE LIFE OF THE CONTRACT, ON AVERAGE AT LEAST 75% OF THE EMPLOYEES OR BIDDERS' AFFILIATE'S OR SUBSIDIARY'S EMPLOYEES ARE RESIDENTS OF WEST VIRGINIA WHO HAVE RESIDED IN THE STATE CONTINUOUSLY FOR THE TWO YEARS IMMEDIATELY PRECEDING SUBMISSION OF THIS BID.</p> <p>BIDDER UNDERSTANDS IF THE SECRETARY OF TAX & REVENUE DETERMINES THAT A BIDDER RECEIVING PREFERENCE HAS FAILED TO CONTINUE TO MEET THE REQUIREMENTS FOR SUCH PREFERENCE, THE SECRETARY MAY ORDER THE DIRECTOR OF PURCHASING TO: (A) RESCIND THE CONTRACT OR PURCHASE ORDER ISSUED; OR (B) ASSESS A PENALTY AGAINST SUCH</p>						N/A

SEE REVERSE SIDE FOR TERMS AND CONDITIONS

SIGNATURE: *[Signature]* TELEPHONE: 888-742-8470 DATE: 3-14-07

FEIN: 41-0116040 ADDRESS CHANGES TO BE NOTED ABOVE

WHEN RESPONDING TO RFQ, INSERT NAME AND ADDRESS IN SPACE ABOVE LABELED 'VENDOR'



State of West Virginia
 Department of Administration
 Purchasing Division
 2019 Washington Street East
 Post Office Box 50130
 Charleston, WV 25305-0130

Request for Quotation

RFQ NUMBER
PKG076200

PAGE
4

ADDRESS CORRESPONDENCE TO ATTENTION OF
**KRISTA FERRELL
 304-558-2596**

RFQ COPY
 TYPE NAME/ADDRESS HERE

 Nilfisk-Advance, Inc.
 14600 21st Avenue, N
 Plymouth, MN 55447

DEPARTMENT OF ADMINISTRATION
 GENERAL SERVICES DIVISION
 BUILDING 13 PARKING GARAGE
 GREENBRIER ST & PIEDMONT RD
 CHARLESTON, WV
 25301 304-558-2317

DATE PRINTED	TERMS OF SALE	SHIP VIA	F.O.B.	FREIGHT TERMS
02/13/2007				

BID OPENING DATE: **03/08/2007** BID OPENING TIME **01:30PM**

LINE	QUANTITY	UOP	CAT NO	ITEM NUMBER	UNIT PRICE	AMOUNT
				= NOT APPLICABLE =		
<p>BIDDER IN AN AMOUNT NOT TO EXCEED 5% OF THE BID AMOUNT AND THAT SUCH PENALTY WILL BE PAID TO THE CONTRACTING AGENCY OR DEDUCTED FROM ANY UNPAID BALANCE ON THE CONTRACT OR PURCHASE ORDER.</p> <p>BY SUBMISSION OF THIS CERTIFICATE, BIDDER AGREES TO DISCLOSE ANY REASONABLY REQUESTED INFORMATION TO THE PURCHASING DIVISION AND AUTHORIZES THE DEPARTMENT OF TAX AND REVENUE TO DISCLOSE TO THE DIRECTOR OF PURCHASING APPROPRIATE INFORMATION VERIFYING THAT BIDDER HAS PAID THE REQUIRED BUSINESS TAXES, PROVIDED THAT SUCH INFORMATION DOES NOT CONTAIN THE AMOUNTS OF TAXES PAID NOR ANY OTHER INFORMATION DEEMED BY THE TAX COMMISSIONER TO BE CONFIDENTIAL.</p> <p>UNDER PENALTY OF LAW FOR FALSE SWEARING (WEST VIRGINIA CODE 61-5-3), BIDDER HEREBY CERTIFIES THAT THIS CERTIFICATE IS TRUE AND ACCURATE IN ALL RESPECTS; AND THAT IF A CONTRACT IS ISSUED TO BIDDER AND IF ANYTHING CONTAINED WITHIN THIS CERTIFICATE CHANGES DURING THE TERM OF THE CONTRACT, BIDDER WILL NOTIFY THE PURCHASING DIVISION IN WRITING IMMEDIATELY.</p> <p>BIDDER: -----</p> <p>DATE: -----</p> <p>SIGNED: -----</p> <p>TITLE: -----</p> <p>* CHECK ANY COMBINATION OF PREFERENCE CONSIDERATION(S)</p>						

N/A

SEE REVERSE SIDE FOR TERMS AND CONDITIONS

SIGNATURE *[Signature]* TELEPHONE **888-742-8470** DATE **3-14-07**
 TITLE **Govt. Contracts Manager** FEIN **41-0116040** ADDRESS CHANGES TO BE NOTED ABOVE

WHEN RESPONDING TO RFQ, INSERT NAME AND ADDRESS IN SPACE ABOVE LABELED 'VENDOR'



State of West Virginia
 Department of Administration
 Purchasing Division
 2019 Washington Street East
 Post Office Box 50130
 Charleston, WV 25305-0130

Request for Quotation

RFQ NUMBER
PKG076200

PAGE
5

ADDRESS CORRESPONDENCE TO ATTENTION OF
**KRISTA FERRELL
 304-558-2596**

SUPPLIER

RFQ COPY
 TYPE NAME/ADDRESS HERE
 Nilfisk-Advance, Inc.
 14600 21st Avenue, N
 Plymouth, MN 55447

SHIP TO

DEPARTMENT OF ADMINISTRATION
 GENERAL SERVICES DIVISION
 BUILDING 13 PARKING GARAGE
 GREENBRIER ST & PIEDMONT RD
 CHARLESTON, WV
 25301 304-558-2317

DATE PRINTED	TERMS OF SALE	SHIP VIA	F.O.B.	FREIGHT TERMS
02/13/2007				
BID OPENING DATE: 03/08/2007		BID OPENING TIME 01:30PM		

LINE	QUANTITY	UOP	CAT NO	ITEM NUMBER	UNIT PRICE	AMOUNT
<p>IN EITHER "A" OR "B", OR BOTH "A" AND "B" WHICH YOU ARE ENTITLED TO RECEIVE. YOU MAY REQUEST UP TO THE MAXIMUM 5% PREFERENCE FOR BOTH "A" AND "B". (REV. 12/00)</p> <p>NOTICE</p> <p>A SIGNED BID MUST BE SUBMITTED TO:</p> <p>DEPARTMENT OF ADMINISTRATION PURCHASING DIVISION BUILDING 15 2019 WASHINGTON STREET, EAST CHARLESTON, WV 25305-0130</p> <p>THE BID SHOULD CONTAIN THIS INFORMATION ON THE FACE OF THE ENVELOPE OR THE BID MAY NOT BE CONSIDERED:</p> <p>SEALED BID</p> <p>BUYER: KF-21</p> <p>RFQ. NO.: PKG076200</p> <p>BID OPENING DATE: 03/08/2007</p> <p>BID OPENING TIME: 1:30 PM</p> <p>PLEASE PROVIDE A FAX NUMBER IN CASE IT IS NECESSARY TO CONTACT YOU REGARDING YOUR BID: 800-989-6566</p>						

SEE REVERSE SIDE FOR TERMS AND CONDITIONS		
SIGNATURE <i>[Signature]</i>	TELEPHONE 888-742-8470	DATE 3-14-07
TELEPHONE Govt. Contracts Manager 41-0116040	ADDRESS CHANGES TO BE NOTED ABOVE	

WHEN RESPONDING TO RFQ, INSERT NAME AND ADDRESS IN SPACE ABOVE LABELED 'VENDOR'



State of West Virginia
 Department of Administration
 Purchasing Division
 2019 Washington Street East
 Post Office Box 50130
 Charleston, WV 25305-0130

Request for Quotation

RFQ NUMBER:
 PKG076200

PAGE:
 6

ADDRESS CORRESPONDENCE TO ATTENTION OF:
 KRISTA FERRELL
 304-558-2596

VENDOR

RFQ COPY
 TYPE NAME/ADDRESS HERE
 Nilfisk-Advance, Inc.
 14600 21st Avenue, N
 Plymouth, MN 55447

SHIP TO

DEPARTMENT OF ADMINISTRATION
 GENERAL SERVICES DIVISION
 BUILDING 13 PARKING GARAGE
 GREENBRIER ST & PIEDMONT RD
 CHARLESTON, WV
 25301 304-558-2317

DATE PRINTED	TERMS OF SALE	SHIP VIA	F.O.B.	FREIGHT TERMS
02/13/2007				

BID OPENING DATE: 03/08/2007 BID OPENING TIME 01:30PM

LINE	QUANTITY	UOP	CAT NO	ITEM NUMBER	UNIT PRICE	AMOUNT
CONTACT PERSON (PLEASE PRINT CLEARLY): BRITTANY BERG						
***** THIS IS THE END OF RFQ PKG076200 ***** TOTAL:						\$31,437. ⁸⁵

SEE REVERSE SIDE FOR TERMS AND CONDITIONS

SIGNATURE: *[Signature]* TELEPHONE: 888-742-8470 DATE: 3-14-07
 TITLE: Govt. Contracts Manager FEE# 41-0116040 ADDRESS CHANGES TO BE NOTED ABOVE

WHEN RESPONDING TO RFQ, INSERT NAME AND ADDRESS IN SPACE ABOVE LABELED 'VENDOR'

REQUEST FOR QUOTATIONS
#PKG076200

The West Virginia Purchasing Division for the West Virginia Department of Administration, General Services Division, is soliciting bids for one (1) Tennant Model #M20 Integrated Scrubber-Sweeper, or equivalent. The Division intends to use the equipment to clean its parking garage facility located at Piedmont Road and Greenbrier Street on a daily basis. This facility has a maximum height of 7 feet 0 inches. Vendor must provide a base cost of the equipment and required accessories, plus a detailed listing of any available options. Available options will not be used to in the evaluation of this equipment.

The desired parking lot sweeper shall meet the following specifications.

1. Scrubber-sweeper will use LPG (liquefied petroleum gas) fuel only No other fuel sources will be accepted;
2. Scrubber-sweeper must have a dust-control system on vehicle at all times, to inhibit damage to vehicles parked within or pedestrians walking within parking garage;
3. Scrubber-sweeper (and all accessories) must be new; neither used or refurbished nor demonstration models will be accepted;
4. Scrubber-sweeper must have the following equipment on base unit: two dry-type two-stage air filters, low/high temperature shutdown system (to prevent equipment damage), electronic instruments (hour meter, oil pressure indicator, amp gauge, water temperature gauge); flashing lights, steering wheel horn, power steering, tilt steering wheel, adjustable seat, armrest, seatbelt, headlights, taillights, and back-up or reverse motion warning system.
5. Scrubber-sweeper must be able to produce a cleaning path of 40-60 inches wet or dry with a forward speed of at least 6 miles per hour.
6. Scrubber-sweeper must be able to operate up to a minimum of one hour on each tank of fuel.
7. Scrubber-sweeper must have brushes and squeegee blades which can be changed out with ease, and with the use of no tools, for cleaning, repair and replacement

The awarded vendor must provide the following additional services:

1. At no additional cost, the successful vendor will train General Services' employees in operation and maintenance of the provided equipment and its accessories. Training will be held at the Capitol Complex, Charleston West

Virginia and will be performed at the time of delivery of equipment or within five working days of the delivery date.

2. The successful vendor will provide a 36-month warranty on the provided equipment (excluding batteries), and at least 24-months in an on-site labor warranty
- 3 The successful vendor must have a service center local enough to provide a less than 24-hour response for service calls for the equipment.

Technical questions and/or clarifications should be addressed in writing to:

Krista Ferrell, Senior Buyer
WV Purchasing Division
2019 Washington, St., East
P O. Box 50130
Charleston, WV 25305-0130
Telephone: (304) 558-2596
Fax: (304) 558-4115
Email: kferrell@wv.admin.gov

009

Required Features for #PKG076200

Base Price \$29,218.⁸⁵

REQUIREMENTS	YES	NO	COST
Hopper Sensors for Fire		X	
Corner Protection Guards (P/N 0780-698)	X		\$ 442.20
On Board Diagnostics	X		No charge
Quick Release of Brushes and Squeegee	X		No charge
Front Wheel Steering		X	
Touch Pad Controls (Waterproof Switches)		X	
Wet/Dry Operations	X		No charge
Safety Cage for Operator (P/N 0780-510)	X		\$976.80
Dump Height to 60 inches (14 inches)		X	
Forward speed of at least 6 miles per hour	X		No charge
Reverse Speed up to 3 miles per hour	X		No charge
Dust Filtration System 3 Microns	X		No charge
Hand Changing of all Brushes and Squeegees	X		No charge
Cleaning Path of 40 - 60 inches	X		No charge
Minimum Brushes 2	X		No charge
Shipping/handling Charges			\$800.-

TOTAL \$31,437.⁸⁵

A F F I D A V I T**West Virginia Code §5A-3-10a states:**

No contract or renewal of any contract may be awarded by the state or any of its political subdivisions to any vendor or prospective vendor when the vendor or prospective vendor or a related party to the vendor or prospective vendor is a debtor and the debt owned is an amount greater than one thousand dollars in the aggregate

DEFINITIONS:

"Debt" means any assessment, premium, penalty, fine, tax or other amount of money owed to the state or any of its political subdivisions because of a judgment, fine, permit violation, license assessment, defaulted workers' compensation premium, penalty or other assessment presently delinquent or due and required to be paid to the state or any of its political subdivisions, including any interest or additional penalties accrued thereon.

"Debtor" means any individual, corporation, partnership, association, limited liability company or any other form or business association owing a debt to the state or any of its political subdivisions. "Political subdivision" means any county commission; municipality; county board of education; any instrumentality established by a county or municipality; any separate corporation or instrumentality established by one or more counties or municipalities, as permitted by law; or any public body charged by law with the performance of a government function or whose jurisdiction is coextensive with one or more counties or municipalities. "Related party" means a party, whether an individual, corporation, partnership, association, limited liability company or any other form or business association or other entity whatsoever, related to any vendor by blood, marriage, ownership or contract through which the party has a relationship of ownership or other interest with the vendor so that the party will actually or by effect receive or control a portion of the benefit, profit or other consideration from performance of a vendor contract with the party receiving an amount that meets or exceeds five percent of the total contract amount.

EXCEPTION:

The prohibition of this section does not apply where a vendor has contested any tax administered pursuant to chapter eleven of this code, workers' compensation premium, permit fee or environmental fee or assessment and the matter has not become final or where the vendor has entered into a payment plan or agreement and the vendor is not in default of any of the provisions of such plan or agreement.

LICENSING:

Vendors must be licensed and in good standing in accordance with any and all state and local laws and requirements by any state or local agency of West Virginia, including, but not limited to, the West Virginia Secretary of State's Office, the West Virginia Tax Department, West Virginia Insurance Commission, or any other state agencies or political subdivision. Furthermore, the vendor must provide all necessary releases to obtain information to enable the Director or spending unit to verify that the vendor is licensed and in good standing with the above entities.

CONFIDENTIALITY:

The vendor agrees that he or she will not disclose to anyone, directly or indirectly, any such personally identifiable information or other confidential information gained from the agency, unless the individual who is the subject of the information consents to the disclosure in writing or the disclosure is made pursuant to the agency's policies, procedures and rules. Vendors should visit www.state.wv.us/admin/purchase/privacy for the Notice of Agency Confidentiality Policies.

Under penalty of law for false swearing (West Virginia Code, §61-5-3), it is hereby certified that the vendor acknowledges the information in this said affidavit and are in compliance with the requirements as stated.

Vendor's Name: NILFISK-ADVANCE, INC.

Authorized Signature: 

Date: 3-14-07

**GENERAL TERMS & CONDITIONS
REQUEST FOR QUOTATION (RFQ) AND REQUEST FOR PROPOSAL (RFP)**

1. Awards will be made in the best interest of the State of West Virginia.
2. The State may accept or reject in part, or in whole, any bid.
3. All quotations are governed by the *West Virginia Code* and the *Legislative Rules* of the Purchasing Division
4. Prior to any award, the apparent successful vendor must be properly registered with the Purchasing Division and have paid the required \$125 00 registration fee
5. All services performed or goods delivered under State Purchase Orders/Contracts are to be continued for the term of the Purchase Order/Contract, contingent upon funds being appropriated by the Legislature or otherwise being made available. In the event funds are not appropriated or otherwise available for these services or goods, this Purchase Order/Contract becomes void and of no effect after June 30.
6. Payment may only be made after the delivery and acceptance of goods or services
7. Interest may be paid for late payment in accordance with the *West Virginia Code*.
8. Vendor preference will be granted upon written request in accordance with the *West Virginia Code*.
9. The State of West Virginia is exempt from federal and state taxes and will not pay or reimburse such taxes.
10. The Director of Purchasing may cancel any Purchase Order/Contract upon 30 days written notice to the seller.
11. The laws of the State of West Virginia and the *Legislative Rules* of the Purchasing Division shall govern all rights and duties under the Contract, including without limitation the validity of this Purchase Order/Contract.
12. Any reference to automatic renewal is hereby deleted. The Contract may be renewed only upon mutual written agreement of the parties.
13. **BANKRUPTCY:** In the event the vendor/contractor files for bankruptcy protection, this contract is automatically null and void, and is terminated without further order.
14. **HIPAA Business Associate Addendum** - The West Virginia State Government HIPAA Business Associate Addendum (BAA), approved by the Attorney General, and available online at the Purchasing Division's web site (<http://www.state.wv.us/admin/purchase/vrc/hipaa.htm>) is hereby made part of the agreement. Provided that, the Agency meets the definition of a Covered Entity (45 CFR §160.103) and will be disclosing Protected Health Information (45 CFR §160.103) to the vendor.

INSTRUCTIONS TO BIDDERS

1. Use the quotation forms provided by the Purchasing Division.
2. **SPECIFICATIONS:** Items offered must be in compliance with the specifications. Any deviation from the specifications must be clearly indicated by the bidder. Alternates offered by the bidder as **EQUAL** to the specifications must be clearly defined. A bidder offering an alternate should attach complete specifications and literature to the bid. The Purchasing Division may waive minor deviations to specifications.
3. Complete all sections of the quotation form.
4. Unit prices shall prevail in cases of discrepancy
5. All quotations are considered F.O.B. destination unless alternate shipping terms are clearly identified in the quotation.
6. **BID SUBMISSION:** All quotations must be delivered by the bidder to the office listed below prior to the date and time of the bid opening. Failure of the bidder to deliver the quotations on time will result in bid disqualifications.

SIGNED BID TO:

Department of Administration
Purchasing Division
2019 Washington Street East
Post Office Box 50130
Charleston, WV 25305-0130



State of West Virginia
 Department of Administration
 Purchasing Division
 2019 Washington Street East
 Post Office Box 50130
 Charleston, WV 25305-0130

Request for Quotation

RFQ NUMBER: PKG076200

PAGE: 1

ADDRESS CORRESPONDENCE TO ATTENTION OF:
 KRISTA FERRELL
 304-558-2596

RFQ COPY

TYPE NAME/ADDRESS HERE

VENDOR

Nilfisk-Advance, Inc.
 14600 21st Avenue, N
 Plymouth, MN 55447

SHIP TO

DEPARTMENT OF ADMINISTRATION
 GENERAL SERVICES DIVISION
 BUILDING 13 PARKING GARAGE
 GREENBRIER ST & PIEDMONT RD
 CHARLESTON, WV
 25301 304-558-2317

DATE PRINTED	TERMS OF SALE	SHIP VIA	F.O.B.	FREIGHT TERMS
02/27/2007				
BID OPENING DATE: 03/15/2007		BID OPENING TIME 01:30PM		

LINE	QUANTITY	UOP	CAT NO	ITEM NUMBER	UNIT PRICE	AMOUNT
ADDENDUM NO. 1						
THIS ADDENDUM IS ISSUED TO ANSWER TECHNICAL QUESTIONS SUBMITTED PRIOR TO THE FEBRUARY 27, 2007 DEADLINE. ALSO TO EXTEND THE BID OPENING DATE.						
BID OPENING DATE IS EXTENDED TO: 03/15/2007						
BID OPENING TIME REMAINS: 1:30 PM						
***** END ADDENDUM NO. 1 *****						
0001	1	EA		765-77		
TENANT M20 INTEGRATED SCRUBBER-SWEEPER, OR EQUAL						
***** THIS IS THE END OF RFQ PKG076200 ***** TOTAL: _____						

SEE REVERSE SIDE FOR TERMS AND CONDITIONS

SIGNATURE <i>[Signature]</i>	TELEPHONE 888-742-8470	DATE 3-14-07
TITLE Govt. Contracts Manager FEIN 41-0116040	ADDRESS CHANGES TO BE NOTED ABOVE	

WHEN RESPONDING TO RFQ, INSERT NAME AND ADDRESS IN SPACE ABOVE LABELED 'VENDOR'

RFQ# PKG076200
Addendum No. 1
Answers to Technical Questions

- 1.) On page 7, item number 5 of your RFQ states Scrubber-sweeper must be able to produce a cleaning path of 40-60 inches wet or dry with a forward speed of at least 6 miles per hour. The Tennant M 20 has two available wet cleaning paths of 40 and 54 (See attached Tennant Technical Spec)? The product we intend to bid as an alternate has three available wet cleaning paths of 43, 48 and 54. To properly comply with the RFQ as stated, I will be forced to quote all three of our models. I assume Tennant will do the same with their two versions. Can you talk with your end users and narrow down the wet cleaning path they need ?

Answer: The original intent of this statement was to provide a cleaning path of at least 40 inches and not to exceed 60 inches wet or dry. We are comfortable and would accept any dimension between 40 and 60 inches for this portion of the specification.

American-Lincoln®

SC7740 Rider Sweeper/Scrubber



www.americanlincoln.com

Powerful Cleaning Capabilities No Longer Cost a Bundle

Extra features can end up costing you a bundle - but that's not the case with the SC7740 rider sweeper/scrubber. American-Lincoln® brings you the extra powerful features and benefits that you would expect in a large piece of cleaning equipment for less money. Want more value for your dollars? Take a look at the SC7740.

One-Pass Cleaning Benefits Include:

- Independent sweeping and dust control allow you the flexibility to sweep, scrub, or do both at the same time
- Powerful hydraulic brush drive motors and increased downward pressure for aggressive scrubbing give you the cleanest floor possible
- Largest solution and recovery tanks for this size machine provide more cleaning for your money

Ergonomic Design Features Include:

- Compact size and power steering for maximum maneuverability and productivity
- Brooms and brushes that raise and lower at the flick of a switch
- Simple drain and clean-out system for increased productivity



A tilt steering wheel and reliable rocker switches make the controls in the operator's compartment easy to use.

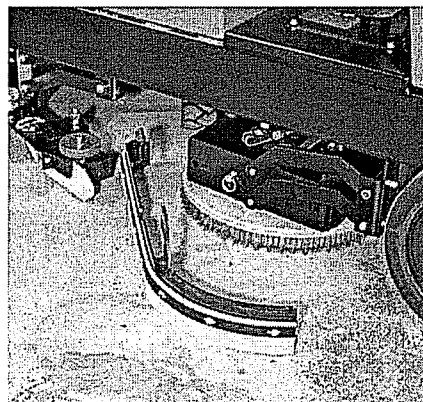

Double-scrub brush design for disk scrubbing offers the most aggressive cleaning action possible.

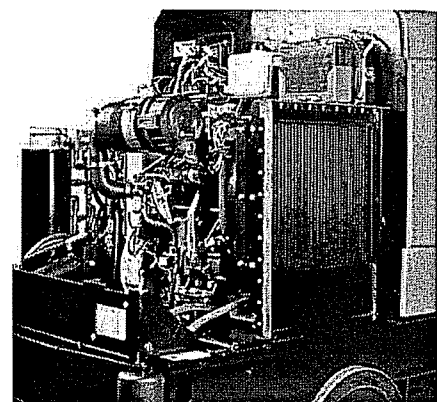

A powerful, yet quiet, liquid-cooled engine teams up with a load-sensing main pump to increase the overall operating life of the system.

Deeply padded seat and power steering in operator's compartment provide top-of-the-line comfort

Large corrosion-proof, impact-resistant Polydur® solution and recovery tanks have a warranty for the life of the machine

Dust control system prevents stirring up even the finest dust while sweeping

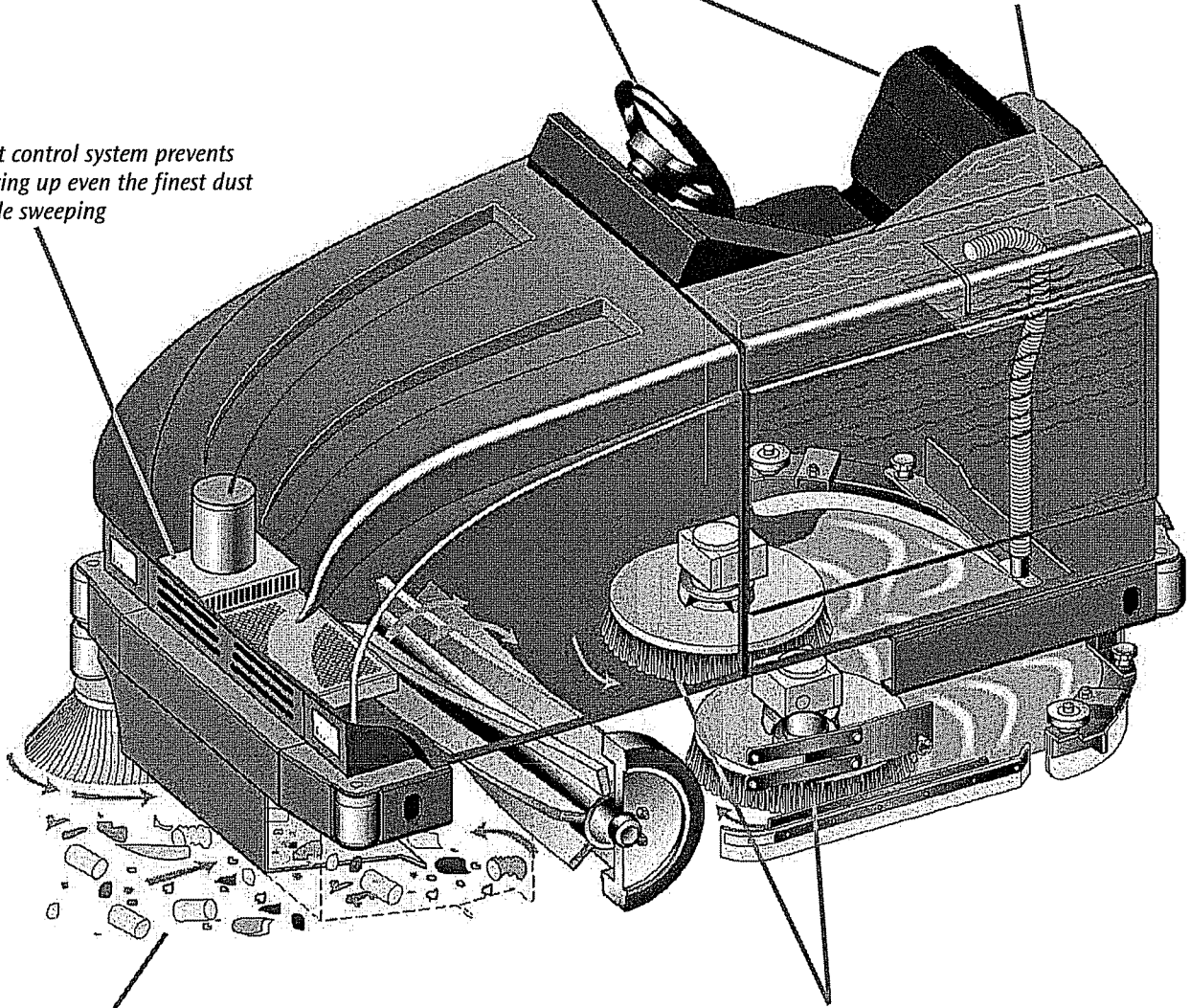

Independent sweeping system in front picks up dirt and debris before scrubbing

Bristle type selection that meets your cleaning needs

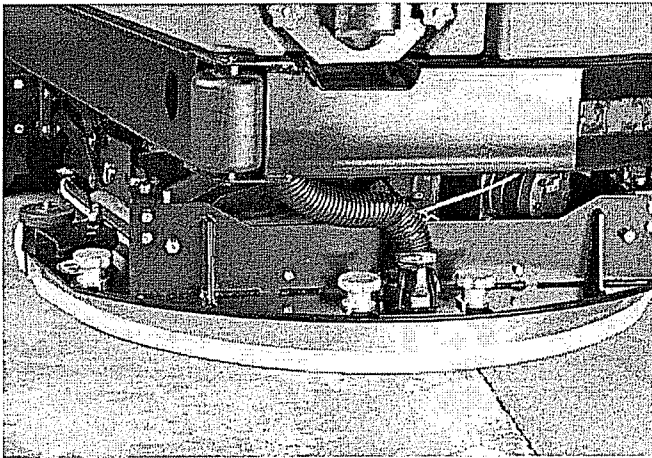

Accu-Track™ squeegee provides superior water pickup even in the tightest of turns.

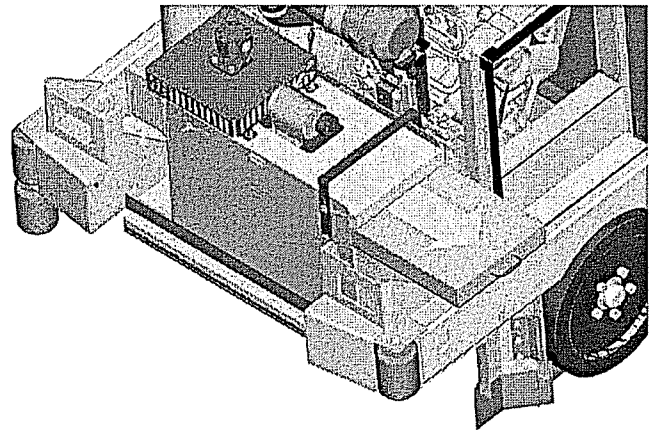

Dust control provides dust-free sweeping before the debris enters the scrubbing area. Slide out filter can be changed in less than 1 minute using no tools.

SC7740

American-Lincoln®

Rider Sweeper/Scrubber

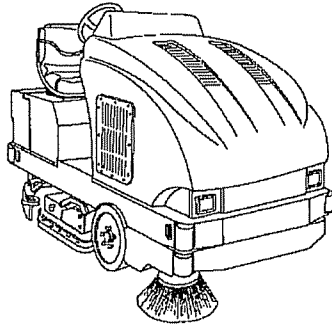

KEY FEATURES

- Two machines in one - sweeper and scrubber to meet your cleaning needs
- Efficient dust control system provides dust-free sweeping
- Water pick-up even in the tightest turns
- Complete hydraulic operation for durability and reliability
- Powerful Kubota engine - a name you can count on

SPECIFICATIONS

Scrub Path	40 in. (101 cm) or 46 in. (117 cm)
Sweep Path	46 in. (117 cm)
Solution Tank	60 gal. (227 l)
Recovery Tank	78 gal. (295 l) with 18 gal. (78 l) demisting chamber
Vacuum Fan	Hydraulically driven, high volume turbine
Hopper Capacity	2.5 cu ft. (71 l)
Brush Drive Motors	High torque, hydraulically driven
Engine	31 hp Kubota
Aisle Turn Radius	87 in. (221 cm)
Dimensions L x W x H	87 x 46 x 59 in. (221 x 116.8 x 150 cm) squeegee width 48 in. (122 cm)
Weight	2,425 lbs. (1,091 kg)

WHO USES THIS MACHINE?

- Manufacturing plants
- Dry goods warehouses
- Food warehouses
- Beverage plants
- Automotive parts warehouses

WHAT DOES IT DO BEST?

- Scrubs aggressively
- Maneuvers well into tight, confined areas
- Reduces operator fatigue with ergonomic operator's compartment
- Provides more productivity and less downtime because of low maintenance

WHAT ENHANCES ITS PRODUCTIVITY?

- Hydraulic drive and power steering system
- Large solution/recovery tanks to stay on the floor longer between cleanups
- One-pass sweeping and scrubbing
- Solution and brushes turn off when machine is not moving

WHAT ADDS TO ITS DURABILITY?

- Heavy gauge welded steel chassis
- Corrosion-proof Polydur® solution/recovery tanks
- Accu-Track™ break-away squeegee
- Durable corner roller bumpers for side protection

WHAT ARE THE SAFETY FEATURES?

- Rack and pinion steering for better handling
- Hopper safety arm
- Excellent line-of-sight from operator's compartment

American-Lincoln

14600 21st Avenue North
Plymouth, MN 55447-3408
www.americanlincoln.com

DISTRIBUTED BY:

Customer Service: 1-800-331-7692
Fax Orders to: 1-877-877-2586
Technical Service: 1-800-331-7691

