



State of West Virginia  
 Department of Administration  
 Purchasing Division  
 2019 Washington Street East  
 Post Office Box 50130  
 Charleston, WV 25305-0130

# Request for Quotation

RFQ NUMBER  
**PC07**

PAGE  
**1**

ADDRESS CORRESPONDENCE TO ATTENTION OF:  
**BETTY FRANCISCO**  
**304-558-0468**

VENDOR

Don McNemar  
 Country Club Chrysler Plymouth Dodge  
 P. O. Box 2321  
 Route 19 South  
 Clarksburg, WV 26302-2321

SHIP TO

ALL STATE AGENCIES  
 AND POLITICAL SUBDIVISIONS  
 VARIOUS LOCALES AS INDICATED  
 BY ORDER

| DATE PRINTED | TERMS OF SALE | SHIP VIA | F.O.B. | FREIGHT TERMS |
|--------------|---------------|----------|--------|---------------|
| 08/31/2006   |               |          |        |               |

BID OPENING DATE: **09/26/2006** BID OPENING TIME **01:30PM**

| LINE   | QUANTITY | UOP | CAT. NO. | ITEM NUMBER   | UNIT PRICE         | AMOUNT             |
|--|----------|-----|----------|---|--------------------|--------------------|
| REQUEST FOR QUOTATION  |          |     |          |   |                    |                    |
| THE PURCHASING DIVISION IS SOLICITING BIDS FOR A BLANKET OPEN-END STATEWIDE CONTRACT TO SUPPLY POLICE VEHICLES TO ALL WEST VIRGINIA STATE AGENCIES AND POLITICAL SUBDIVISIONS. |          |     |          |   |                    |                    |
| THE RESULTING CONTRACT(S) SHALL BE TO SUPPLY 2007 (OR CURRENT YEAR MODEL) VEHICLES.  |          |     |          |   |                    |                    |
| SEE THE ATTACHED SPECIFICATIONS FOR THE REQUIREMENTS OF EACH VEHICLE.  |          |     |          |   |                    |                    |
| 0001   | 1        | EA  |          | 070-06-01-000                                       |                    |                    |
|  |          |     |          | 2007 FORD CROWN VICTORIA POLICE INTERCEPTOR         | <b>NO BID</b>      |                    |
| 0002   | 1        | EA  |          | 070-06-99-000                                       |                    |                    |
|  |          |     |          | 2007 CHEVROLET IMPALA POLICE PURSUIT VEHICLE        | <b>NO BID</b>      |                    |
| 0003   | 1        | EA  |          | 070-06-99-000                                       | <b>\$20,583.00</b> | <b>\$20,583.00</b> |
|  |          |     |          | 2007 FULL SIZE, FOUR DOOR, FOUR WHEEL DRIVE UTILITY |                    |                    |

SEE REVERSE SIDE FOR TERMS AND CONDITIONS

|                        |                           |                                   |
|------------------------|---------------------------|-----------------------------------|
| SIGNATURE<br>          | TELEPHONE<br>304-624-7611 | DATE<br>Oct 11 2006               |
| TITLE<br>FLEET MANAGER | FEIN<br>550567749         | ADDRESS CHANGES TO BE NOTED ABOVE |

WHEN RESPONDING TO RFQ, INSERT NAME AND ADDRESS IN SPACE ABOVE LABELED 'VENDOR'

**GENERAL TERMS & CONDITIONS  
REQUEST FOR QUOTATION (RFQ) AND REQUEST FOR PROPOSAL (RFP)**

1. Awards will be made in the best interest of the State of West Virginia.
2. The State may accept or reject in part, or in whole, any bid.
3. All quotations are governed by the *West Virginia Code* and the *Legislative Rules* of the Purchasing Division.
4. Prior to any award, the apparent successful vendor must be properly registered with the Purchasing Division and have paid the required \$125.00 registration fee.
5. All services performed or goods delivered under State Purchase Orders/Contracts are to be continued for the term of the Purchase Order/Contract, contingent upon funds being appropriated by the Legislature or otherwise being made available. In the event funds are not appropriated or otherwise available for these services or goods, this Purchase Order/Contract becomes void and of no effect after June 30.
6. Payment may only be made after the delivery and acceptance of goods or services.
7. Interest may be paid for late payment in accordance with the *West Virginia Code*.
8. Vendor preference will be granted upon written request in accordance with the *West Virginia Code*.
9. The State of West Virginia is exempt from federal and state taxes and will not pay or reimburse such taxes.
10. The Director of Purchasing may cancel any Purchase Order/Contract upon 30 days written notice to the seller.
11. The laws of the State of West Virginia and the *Legislative Rules* of the Purchasing Division shall govern all rights and duties under the Contract, including without limitation the validity of this Purchase Order/Contract.
12. Any reference to automatic renewal is hereby deleted. The Contract may be renewed only upon mutual written agreement of the parties.
13. **BANKRUPTCY:** In the event the vendor/contractor files for bankruptcy protection, this contract is automatically null and void, and is terminated without further order.
14. **HIPAA Business Associate Addendum** - The West Virginia State Government HIPAA Business Associate Addendum (BAA), approved by the Attorney General, and available online at the Purchasing Division's web site (<http://www.state.wv.us/admin/purchase/vrc/hipaa.htm>) is hereby made part of the agreement. Provided that, the Agency meets the definition of a Covered Entity (45 CFR §160.103) and will be disclosing Protected Health Information (45 CFR §160.103) to the vendor.

---

**INSTRUCTIONS TO BIDDERS**

1. Use the quotation forms provided by the Purchasing Division.
2. **SPECIFICATIONS:** Items offered must be in compliance with the specifications. Any deviation from the specifications must be clearly indicated by the bidder. Alternates offered by the bidder as **EQUAL** to the specifications must be clearly defined. A bidder offering an alternate should attach complete specifications and literature to the bid. The Purchasing Division may waive minor deviations to specifications.
3. Complete all sections of the quotation form.
4. Unit prices shall prevail in cases of discrepancy.
5. All quotations are considered F.O.B. destination unless alternate shipping terms are clearly identified in the quotation.
6. **BID SUBMISSION:** All quotations must be delivered by the bidder to the office listed below prior to the date and time of the bid opening. Failure of the bidder to deliver the quotations on time will result in bid disqualifications.

**SIGNED BID TO:**

Department of Administration  
Purchasing Division  
2019 Washington Street East  
Post Office Box 50130  
Charleston, WV 25305-0130



State of West Virginia  
 Department of Administration  
 Purchasing Division  
 2019 Washington Street East  
 Post Office Box 50130  
 Charleston, WV 25305-0130

# Request for Quotation

RFQ NUMBER  
**PC07**

PAGE  
**2**

ADDRESS CORRESPONDENCE TO ATTENTION OF:  
**BETTY FRANCISCO**  
**304-558-0468**

**COUNTRY CLUB CHRYSLER**  
**DODGE SPRINTER**  
**PO BOX 2321**  
**CLARKSBURG, WV 26302-2321**

VENDOR

SHIP TO

ALL STATE AGENCIES  
 AND POLITICAL SUBDIVISIONS  
 VARIOUS LOCALES AS INDICATED  
 BY ORDER

|                                   |               |          |        |               |
|-----------------------------------|---------------|----------|--------|---------------|
| DATE PRINTED<br><b>08/31/2006</b> | TERMS OF SALE | SHIP VIA | F.O.B. | FREIGHT TERMS |
|-----------------------------------|---------------|----------|--------|---------------|

BID OPENING DATE: **09/26/2006** BID OPENING TIME **01:30PM**

| LINE  | QUANTITY | UOP | CAT NO | ITEM NUMBER   | UNIT PRICE         | AMOUNT             |
|---|----------|-----|--------|---------------|--------------------|--------------------|
| 0004  | 1        | EA  |        | 070-06-99-002 | <b>\$18,921.00</b> | <b>\$18,921.00</b> |
| <p>2007 DODGE CHARGER POLICE PURSUIT VEHICLE</p> <p>WRITTEN QUESTIONS REGARDING THIS REQUEST FOR QUOTATION SHOULD BE DIRECTED TO:</p> <p>BETTY FRANCISCO, SENIOR BUYER<br/>         PURCHASING DIVISION<br/>         P. O. BOX 50130<br/>         CHARLESTON, WV 25305-0130<br/>         FAX: 304-558-4115<br/>         E-MAIL: BFRANCISCO@WVADMIN.GOV</p> <p>WRITTEN QUESTIONS SHALL BE ACCEPTED THROUGH CLOSE OF BUSINESS ON WEDNESDAY, SEPTEMBER 13, 2006. AFTER THAT TIME, ONLY QUESTIONS CONCERNING BID SUBMITTAL SHALL BE ACCEPTED.</p> <p>REPORTS:<br/>         SUCCESSFUL VENDORS SHALL BE REQUIRED TO SUBMIT A REPORT (DUE AUGUST 1, 2007) DETAILING THE NUMBER OF VEHICLES AND TOTAL DOLLARS OF SALES TO DATE. IT WOULD BE HELPFUL IF THIS REPORT INCLUDED THE AGENCY OR POLITICAL SUBDIVISION MAKING THE PURCHASE(S).</p> <p>EXHIBIT 2</p> <p>LIFE OF CONTRACT: THIS CONTRACT BECOMES EFFECTIVE ON ..... AND EXTENDS FOR A PERIOD OF ONE (1) YEAR OR UNTIL SUCH "REASONABLE TIME" THEREAFTER AS IS NECESSARY TO OBTAIN A NEW CONTRACT OR RENEW THE ORIGINAL CONTRACT. THE "REASONABLE TIME" PERIOD SHALL</p> |          |     |        |               |                    |                    |

SEE REVERSE SIDE FOR TERMS AND CONDITIONS

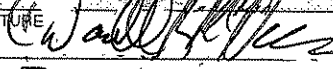
SIGNATURE  TELEPHONE **304-624-2611** DATE **10-11-06**

TITLE **Walter Klumb** FEIN ADDRESS CHANGES TO BE NOTED ABOVE

WHEN RESPONDING TO RFQ, INSERT NAME AND ADDRESS IN SPACE ABOVE LABELED 'VENDOR'



State of West Virginia  
 Department of Administration  
 Purchasing Division  
 2019 Washington Street East  
 Post Office Box 50130  
 Charleston, WV 25305-0130

# Request for Quotation

RFQ NUMBER  
**PC07**

PAGE  
**3**

ADDRESS CORRESPONDENCE TO ATTENTION OF:  
**BETTY FRANCISCO**  
**304-558-0468**

RFQ COPY  
 TYPE NAME/ADDRESS HERE

VENDOR

SHIP TO

ALL STATE AGENCIES  
 AND POLITICAL SUBDIVISIONS  
 VARIOUS LOCALES AS INDICATED  
 BY ORDER

|                                   |               |          |        |               |
|-----------------------------------|---------------|----------|--------|---------------|
| DATE PRINTED<br><b>08/31/2006</b> | TERMS OF SALE | SHIP VIA | F.O.B. | FREIGHT TERMS |
|-----------------------------------|---------------|----------|--------|---------------|

BID OPENING DATE: **09/26/2006** BID OPENING TIME **01:30PM**

| LINE  | QUANTITY | UOP | CAT. NO. | ITEM NUMBER | UNIT PRICE | AMOUNT |
|---|----------|-----|----------|-------------|------------|--------|
| <p>NOT EXCEED TWELVE (12) MONTHS. DURING THIS "REASONABLE TIME" THE VENDOR MAY TERMINATE THIS CONTRACT FOR ANY REASON UPON GIVING THE DIRECTOR OF PURCHASING THIRTY (30) DAYS WRITTEN NOTICE.</p> <p>UNLESS SPECIFIC PROVISIONS ARE STIPULATED IN THIS CONTRACT DOCUMENT, THE TERMS, CONDITIONS, AND PRICING SET HEREIN ARE FIRM FOR THE LIFE OF THE CONTRACT.</p> <p>RENEWAL: THIS CONTRACT MAY BE RENEWED UPON THE MUTUAL WRITTEN CONSENT OF THE SPENDING UNIT AND VENDOR, SUBMITTED TO THE DIRECTOR OF PURCHASING THIRTY (30) DAYS PRIOR TO THE EXPIRATION DATE. SUCH RENEWAL SHALL BE IN ACCORDANCE WITH THE TERMS AND CONDITIONS OF THE ORIGINAL CONTRACT AND SHALL BE LIMITED TO TWO (2) ONE (1) YEAR PERIODS.</p> <p>CANCELLATION: THE DIRECTOR OF PURCHASING RESERVES THE RIGHT TO CANCEL THIS CONTRACT IMMEDIATELY UPON WRITTEN NOTICE TO THE VENDOR IF THE COMMODITIES AND/OR SERVICES SUPPLIED ARE OF AN INFERIOR QUALITY OR DO NOT CONFORM WITH THE SPECIFICATIONS OF THE BID AND CONTRACT HEREIN.</p> <p>OPEN MARKET CLAUSE: THE DIRECTOR OF PURCHASING MAY AUTHORIZE A SPENDING UNIT TO PURCHASE ON THE OPEN MARKET, WITHOUT THE FILING OF A REQUISITION OR COST ESTIMATE, ITEMS SPECIFIED ON THIS CONTRACT FOR IMMEDIATE DELIVERY IN EMERGENCIES DUE TO UNFORESEEN CAUSES (INCLUDING BUT NOT LIMITED TO DELAYS IN TRANSPORTATION OR AN UNANTICIPATED INCREASE IN THE VOLUME OF WORK).</p> <p>QUANTITIES: QUANTITIES LISTED IN THE REQUISITION ARE APPROXIMATIONS ONLY, BASED ON ESTIMATES SUPPLIES BY THE STATE SPENDING UNIT. IT IS UNDERSTOOD AND AGREED THAT THE CONTRACT SHALL COVER THE QUANTITIES ACTUALLY ORDERED FOR DELIVERY DURING THE TERM OF CONTRACT,</p> |          |     |          |             |            |        |

SEE REVERSE SIDE FOR TERMS AND CONDITIONS

|           |           |      |
|-----------|-----------|------|
| SIGNATURE | TELEPHONE | DATE |
|-----------|-----------|------|

|       |      |                                   |
|-------|------|-----------------------------------|
| TITLE | FEIN | ADDRESS CHANGES TO BE NOTED ABOVE |
|-------|------|-----------------------------------|

WHEN RESPONDING TO RFQ, INSERT NAME AND ADDRESS IN SPACE ABOVE LABELED 'VENDOR'





State of West Virginia  
 Department of Administration  
 Purchasing Division  
 2019 Washington Street East  
 Post Office Box 50130  
 Charleston, WV 25305-0130

# Request for Quotation

|                     |
|---------------------|
| RFQ NUMBER:<br>PC07 |
|---------------------|

|            |
|------------|
| PAGE:<br>4 |
|------------|

|  |
|--|
| ADDRESS CORRESPONDENCE TO ATTENTION OF:<br>BETTY FRANCISCO<br>304-558-0468 |
|--|

VENDOR

RFQ COPY  
 TYPE NAME/ADDRESS HERE

SHIP TO

ALL STATE AGENCIES  
 AND POLITICAL SUBDIVISIONS  
 VARIOUS LOCALES AS INDICATED  
 BY ORDER

|                            |               |          |        |               |
|----------------------------|---------------|----------|--------|---------------|
| DATE PRINTED<br>08/31/2006 | TERMS OF SALE | SHIP VIA | F.O.B. | FREIGHT TERMS |
|----------------------------|---------------|----------|--------|---------------|

BID OPENING DATE: 09/26/2006 BID OPENING TIME 01:30PM

| LINE  | QUANTITY | UOP | CAT NO. | ITEM NUMBER | UNIT PRICE | AMOUNT |
|---|----------|-----|---------|-------------|------------|--------|
| <p>WHETHER MORE OR LESS THAN THE QUANTITIES SHOWN.</p> <p>ORDERING PROCEDURE: SPENDING UNIT(S) SHALL ISSUE A WRITTEN EQUIPMENT CONTRACT ORDER (FORM NUMBER WV-35) FOR COMMODITIES COVERED BY THIS CONTRACT. THE ORIGINAL WV-35 MUST BE SENT TO THE PURCHASING DIVISION OF THE DEPARTMENT OF ADMINISTRATION. AFTER APPROVAL AND ENCUMBRANCE, ONE COPY OF THE PURCHASE ORDER WILL BE RETURNED TO THE SPENDING UNIT AND ONE COPY FORWARDED TO THE VENDOR AS AUTHORIZATION FOR SHIPMENT. NO ORDER IS VALID UNLESS APPROVED AND ENCUMBERED BY THE PURCHASING DIVISION.</p> <p>BANKRUPTCY: IN THE EVENT THE VENDOR/CONTRACTOR FILES FOR BANKRUPTCY PROTECTION, THIS CONTRACT IS AUTOMATICALLY NULL AND VOID, AND IS TERMINATED WITHOUT FURTHER ORDER.</p> <p>EXHIBIT 4</p> <p>LOCAL GOVERNMENT BODIES: UNLESS THE VENDOR INDICATES IN THE BID HIS REFUSAL TO EXTEND THE PRICES, TERMS, AND CONDITIONS OF THE BID TO COUNTY, SCHOOL, MUNICIPAL AND OTHER LOCAL GOVERNMENT BODIES, THE BID SHALL EXTEND TO POLITICAL SUBDIVISIONS OF THE STATE OF WEST VIRGINIA. IF THE VENDOR DOES NOT WISH TO EXTEND THE PRICES, TERMS, AND CONDITIONS OF THE BID TO ALL POLITICAL SUBDIVISIONS OF THE STATE, THE VENDOR MUST CLEARLY INDICATE SUCH REFUSAL IN HIS BID. SUCH REFUSAL SHALL NOT PREJUDICE THE AWARD OF THIS CONTRACT IN ANY MANNER.</p> <p style="text-align: center;">VENDOR PREFERENCE CERTIFICATE</p> |          |     |         |             |            |        |

SEE REVERSE SIDE FOR TERMS AND CONDITIONS

|           |           |      |
|-----------|-----------|------|
| SIGNATURE | TELEPHONE | DATE |
|-----------|-----------|------|

|       |      |                                   |
|-------|------|-----------------------------------|
| TITLE | FEIN | ADDRESS CHANGES TO BE NOTED ABOVE |
|-------|------|-----------------------------------|

WHEN RESPONDING TO RFQ, INSERT NAME AND ADDRESS IN SPACE ABOVE LABELED 'VENDOR'



State of West Virginia  
 Department of Administration  
 Purchasing Division  
 2019 Washington Street East  
 Post Office Box 50130  
 Charleston, WV 25305-0130

# Request for Quotation

RFQ NUMBER:  
**PC07**

PAGE:  
**5**

ADDRESS CORRESPONDENCE TO ATTENTION OF:  
**BETTY FRANCISCO  
 304-558-0468**

RFQ COPY  
 TYPE NAME/ADDRESS HERE

VENDOR

SHIP TO

ALL STATE AGENCIES  
 AND POLITICAL SUBDIVISIONS  
 VARIOUS LOCALES AS INDICATED  
 BY ORDER

| DATE PRINTED | TERMS OF SALE | SHIP VIA | F.O.B. | FREIGHT TERMS |
|--------------|---------------|----------|--------|---------------|
| 08/31/2006   |               |          |        |               |

BID OPENING DATE: **09/26/2006** BID OPENING TIME **01:30PM**

| LINE  | QUANTITY | UOP | CAT. NO. | ITEM NUMBER | UNIT PRICE | AMOUNT |
|---|----------|-----|----------|-------------|------------|--------|
| <p>CERTIFICATION AND APPLICATION* IS HEREBY MADE FOR PREFERENCE IN ACCORDANCE WITH WEST VIRGINIA CODE, 5A-3-37 (DOES NOT APPLY TO CONSTRUCTION CONTRACTS).</p> <p>A. APPLICATION IS MADE FOR 2.5% PREFERENCE FOR THE REASON CHECKED:</p> <p>BIDDER IS AN INDIVIDUAL RESIDENT VENDOR AND HAS RESIDED CONTINUOUSLY IN WEST VIRGINIA FOR FOUR (4) YEARS IMMEDIATELY PRECEDING THE DATE OF THIS CERTIFICATION; OR</p> <p><input checked="" type="checkbox"/> BIDDER IS A PARTNERSHIP, ASSOCIATION OR CORPORATION RESIDENT VENDOR AND HAS MAINTAINED ITS HEAD-QUARTERS OR PRINCIPAL PLACE OF BUSINESS CONTINUOUSLY IN WEST VIRGINIA FOR FOUR (4) YEARS IMMEDIATELY PRECEDING THE DATE OF THIS CERTIFICATION; OR 80% OF THE OWNERSHIP INTEREST OF BIDDER IS HELD BY ANOTHER INDIVIDUAL, PARTNERSHIP, ASSOCIATION OR CORPORATION RESIDENT VENDOR WHO HAS MAINTAINED ITS HEADQUARTERS OR PRINCIPAL PLACE OF BUSINESS CONTINUOUSLY IN WEST VIRGINIA FOR FOUR (4) YEARS IMMEDIATELY PRECEDING THE DATE OF THIS CERTIFICATION; OR</p> <p>( ) BIDDER IS A CORPORATION NONRESIDENT VENDOR WHICH HAS AN AFFILIATE OR SUBSIDIARY WHICH EMPLOYS A MINIMUM OF ONE HUNDRED STATE RESIDENTS AND WHICH HAS MAINTAINED ITS HEADQUARTERS OR PRINCIPAL PLACE OF BUSINESS WITHIN WEST VIRGINIA CONTINUOUSLY FOR THE FOUR (4) YEARS IMMEDIATELY PRECEDING THE DATE OF THIS CERTIFICATION.</p> <p>B. APPLICATION IS MADE FOR 2.5% PREFERENCE FOR THE REASON CHECKED:</p> <p><input checked="" type="checkbox"/> BIDDER IS A RESIDENT VENDOR WHO CERTIFIES THAT,</p> |          |     |          |             |            |        |

SEE REVERSE SIDE FOR TERMS AND CONDITIONS

SIGNATURE:   
 TELEPHONE: \_\_\_\_\_ DATE: **10-11-06**

TITLE: \_\_\_\_\_ FEIN: \_\_\_\_\_ ADDRESS CHANGES TO BE NOTED ABOVE

WHEN RESPONDING TO RFQ, INSERT NAME AND ADDRESS IN SPACE ABOVE LABELED 'VENDOR'



State of West Virginia  
 Department of Administration  
 Purchasing Division  
 2019 Washington Street East  
 Post Office Box 50130  
 Charleston, WV 25305-0130

# Request for Quotation

|            |
|------------|
| RFQ NUMBER |
| PC07       |

|      |
|------|
| PAGE |
| 6    |

|   |
|---|
| ADDRESS CORRESPONDENCE TO ATTENTION OF: |
| BETTY FRANCISCO<br>304-558-0468         |

RFQ COPY  
 TYPE NAME/ADDRESS HERE

VENDOR

SHIP TO

ALL STATE AGENCIES  
 AND POLITICAL SUBDIVISIONS  
 VARIOUS LOCALES AS INDICATED  
 BY ORDER

|              |               |          |        |               |
|--------------|---------------|----------|--------|---------------|
| DATE PRINTED | TERMS OF SALE | SHIP VIA | F.O.B. | FREIGHT TERMS |
| 08/31/2006   |               |          |        |               |

BID OPENING DATE: 09/26/2006 BID OPENING TIME 01:30PM

| LINE   | QUANTITY | UOP | CAT NO | ITEM NUMBER | UNIT PRICE | AMOUNT |
|--|----------|-----|--------|-------------|------------|--------|
| <p>DURING THE LIFE OF THE CONTRACT, ON AVERAGE AT LEAST 75% OF THE EMPLOYEES WORKING ON THE PROJECT BEING BID ARE RESIDENTS OF WEST VIRGINIA WHO HAVE RESIDED IN THE STATE CONTINUOUSLY FOR THE TWO YEARS IMMEDIATELY PRECEDING SUBMISSION OF THIS BID;<br/>           OR<br/>           ( ) BIDDER IS A NONRESIDENT VENDOR EMPLOYING A MINIMUM OF ONE HUNDRED STATE RESIDENTS OR IS A NONRESIDENT VENDOR WITH AN AFFILIATE OR SUBSIDIARY WHICH MAINTAINS ITS HEADQUARTERS OR PRINCIPAL PLACE OF BUSINESS WITHIN WEST VIRGINIA EMPLOYING A MINIMUM OF ONE HUNDRED STATE RESIDENTS WHO CERTIFIES THAT, DURING THE LIFE OF THE CONTRACT, ON AVERAGE AT LEAST 75% OF THE EMPLOYEES OR BIDDERS' AFFILIATE'S OR SUBSIDIARY'S EMPLOYEES ARE RESIDENTS OF WEST VIRGINIA WHO HAVE RESIDED IN THE STATE CONTINUOUSLY FOR THE TWO YEARS IMMEDIATELY PRECEDING SUBMISSION OF THIS BID.</p> <p>BIDDER UNDERSTANDS IF THE SECRETARY OF TAX &amp; REVENUE DETERMINES THAT A BIDDER RECEIVING PREFERENCE HAS FAILED TO CONTINUE TO MEET THE REQUIREMENTS FOR SUCH PREFERENCE, THE SECRETARY MAY ORDER THE DIRECTOR OF PURCHASING TO: (A) RESCIND THE CONTRACT OR PURCHASE ORDER ISSUED; OR (B) ASSESS A PENALTY AGAINST SUCH BIDDER IN AN AMOUNT NOT TO EXCEED 5% OF THE BID AMOUNT AND THAT SUCH PENALTY WILL BE PAID TO THE CONTRACTING AGENCY OR DEDUCTED FROM ANY UNPAID BALANCE ON THE CONTRACT OR PURCHASE ORDER.</p> <p>BY SUBMISSION OF THIS CERTIFICATE, BIDDER AGREES TO DISCLOSE ANY REASONABLY REQUESTED INFORMATION TO THE PURCHASING DIVISION AND AUTHORIZES THE DEPARTMENT OF TAX AND REVENUE TO DISCLOSE TO THE DIRECTOR OF PURCHASING APPROPRIATE INFORMATION VERIFYING THAT BIDDER HAS PAID THE REQUIRED BUSINESS TAXES, PROVIDED THAT SUCH INFORMATION DOES NOT CONTAIN THE AMOUNTS OF</p> |          |     |        |             |            |        |

SEE REVERSE SIDE FOR TERMS AND CONDITIONS

|           |           |      |
|-----------|-----------|------|
| SIGNATURE | TELEPHONE | DATE |
|-----------|-----------|------|

|       |      |                                   |
|-------|------|-----------------------------------|
| TITLE | FEIN | ADDRESS CHANGES TO BE NOTED ABOVE |
|-------|------|-----------------------------------|

WHEN RESPONDING TO RFQ, INSERT NAME AND ADDRESS IN SPACE ABOVE LABELED 'VENDOR'



State of West Virginia  
 Department of Administration  
 Purchasing Division  
 2019 Washington Street East  
 Post Office Box 50130  
 Charleston, WV 25305-0130

# Request for Quotation

RFQ NUMBER  
**PC07**

PAGE  
**7**

ADDRESS CORRESPONDENCE TO ATTENTION OF:  
**BETTY FRANCISCO**  
**304-558-0468**

RFQ COPY  
 TYPE NAME/ADDRESS HERE

V  
E  
N  
D  
O  
R

S  
H  
I  
P  
T  
O

ALL STATE AGENCIES  
 AND POLITICAL SUBDIVISIONS  
 VARIOUS LOCALES AS INDICATED  
 BY ORDER

|                                   |               |          |        |               |
|-----------------------------------|---------------|----------|--------|---------------|
| DATE PRINTED<br><b>08/31/2006</b> | TERMS OF SALE | SHIP VIA | F.O.B. | FREIGHT TERMS |
|-----------------------------------|---------------|----------|--------|---------------|

BID OPENING DATE: **09/26/2006** BID OPENING TIME **01:30PM**

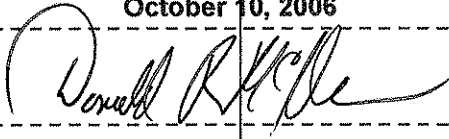
| LINE   | QUANTITY | UOP | CAT. NO. | ITEM NUMBER | UNIT PRICE | AMOUNT |
|--|----------|-----|----------|-------------|------------|--------|
| <p>TAXES PAID NOR ANY OTHER INFORMATION DEEMED BY THE TAX COMMISSIONER TO BE CONFIDENTIAL.</p> <p>UNDER PENALTY OF LAW FOR FALSE SWEARING (WEST VIRGINIA CODE 61-5-3), BIDDER HEREBY CERTIFIES THAT THIS CERTIFICATE IS TRUE AND ACCURATE IN ALL RESPECTS; AND THAT IF A CONTRACT IS ISSUED TO BIDDER AND IF ANYTHING CONTAINED WITHIN THIS CERTIFICATE CHANGES DURING THE TERM OF THE CONTRACT, BIDDER WILL NOTIFY THE PURCHASING DIVISION IN WRITING IMMEDIATELY.</p> <p>BIDDER: <b>COUNTRY CLUB CHRYSLER DODGE INC.</b></p> <p>DATE: <b>October 10, 2006</b></p> <p>SIGNED: </p> <p>TITLE: <b>FLEET MANAGER</b></p> <p>* CHECK ANY COMBINATION OF PREFERENCE CONSIDERATION(S) IN EITHER "A" OR "B", OR BOTH "A" AND "B" WHICH YOU ARE ENTITLED TO RECEIVE. YOU MAY REQUEST UP TO THE MAXIMUM 5% PREFERENCE FOR BOTH "A" AND "B".</p> <p>NOTICE</p> <p>AN ORIGINAL, SIGNED BID MUST BE SUBMITTED (AND ONE CONVENIENCE COPY IS REQUESTED) TO:</p> <p>DEPARTMENT OF ADMINISTRATION</p> |          |     |          |             |            |        |

SEE REVERSE SIDE FOR TERMS AND CONDITIONS

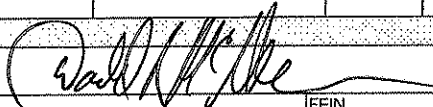
|  |           |      |
|--|-----------|------|
| SIGNATURE<br> | TELEPHONE | DATE |
|--|-----------|------|

|       |      |                                   |
|-------|------|-----------------------------------|
| TITLE | FEIN | ADDRESS CHANGES TO BE NOTED ABOVE |
|-------|------|-----------------------------------|

WHEN RESPONDING TO RFQ, INSERT NAME AND ADDRESS IN SPACE ABOVE LABELED 'VENDOR'



State of West Virginia  
 Department of Administration  
 Purchasing Division  
 2019 Washington Street East  
 Post Office Box 50130  
 Charleston, WV 25305-0130

# Request for Quotation

RFQ NUMBER  
**PC07**

PAGE  
**8**

ADDRESS CORRESPONDENCE TO ATTENTION OF:  
**BETTY FRANCISCO**  
**304-558-0468**

VENDOR

RFQ COPY  
 TYPE NAME/ADDRESS HERE

SHIP TO

ALL STATE AGENCIES  
 AND POLITICAL SUBDIVISIONS  
 VARIOUS LOCALES AS INDICATED  
 BY ORDER

|                                   |               |          |        |               |
|-----------------------------------|---------------|----------|--------|---------------|
| DATE PRINTED<br><b>08/31/2006</b> | TERMS OF SALE | SHIP VIA | F.O.B. | FREIGHT TERMS |
|-----------------------------------|---------------|----------|--------|---------------|

BID OPENING DATE: **09/26/2006**      BID OPENING TIME **01:30PM**

| LINE  | QUANTITY  | UOP | CAT NO | ITEM NUMBER | UNIT PRICE | AMOUNT |
|---|---|-----|--------|-------------|------------|--------|
|   | PURCHASING DIVISION<br>BUILDING 15<br>2019 WASHINGTON STREET, EAST<br>CHARLESTON, WV 25305-0130 |     |        |             |            |        |
| YOUR BID MUST CONTAIN THIS INFORMATION ON THE FACE OF THE ENVELOPE OR THE BID MAY NOT BE CONSIDERED:<br><br>SEALED BID  |   |     |        |             |            |        |
| BUYER:-----BETTY L. FRANCISCO - FILE 42-----<br>RFQ. NO.:-----PC07-----<br>BID OPENING DATE:--TUESDAY, SEPTEMBER 26, 2006-----<br>BID OPENING TIME:--1:30 P.M.----- |   |     |        |             |            |        |
| PLEASE PROVIDE A FAX NUMBER IN CASE IT IS NECESSARY TO CONTACT YOU REGARDING YOUR BID:<br><b>304-624-7611</b>   |   |     |        |             |            |        |
| CONTACT PERSON (PLEASE PRINT CLEARLY):<br><b>DON McNEMAR</b>  |   |     |        |             |            |        |

SEE REVERSE SIDE FOR TERMS AND CONDITIONS

|           |           |      |
|-----------|-----------|------|
| SIGNATURE | TELEPHONE | DATE |
|-----------|-----------|------|

|       |      |                                   |
|-------|------|-----------------------------------|
| TITLE | FEIN | ADDRESS CHANGES TO BE NOTED ABOVE |
|-------|------|-----------------------------------|

WHEN RESPONDING TO RFQ, INSERT NAME AND ADDRESS IN SPACE ABOVE LABELED 'VENDOR'



State of West Virginia  
 Department of Administration  
 Purchasing Division  
 2019 Washington Street East  
 Post Office Box 50130  
 Charleston, WV 25305-0130

# Request for Quotation

|            |
|------------|
| RFQ NUMBER |
| PC07       |

|      |
|------|
| PAGE |
| 9    |

|   |
|---|
| ADDRESS CORRESPONDENCE TO ATTENTION OF: |
| BETTY FRANCISCO<br>304-558-0468         |

RFQ COPY  
 TYPE NAME/ADDRESS HERE

VENDOR

SHIP TO

ALL STATE AGENCIES  
 AND POLITICAL SUBDIVISIONS  
 VARIOUS LOCALES AS INDICATED  
 BY ORDER

|              |               |          |        |               |
|--------------|---------------|----------|--------|---------------|
| DATE PRINTED | TERMS OF SALE | SHIP VIA | F.O.B. | FREIGHT TERMS |
| 08/31/2006   |               |          |        |               |

BID OPENING DATE: 09/26/2006 BID OPENING TIME 01:30PM

| LINE   | QUANTITY | UOP | CAT NO | ITEM NUMBER | UNIT PRICE | AMOUNT |
|--|----------|-----|--------|-------------|------------|--------|
| ***** THIS IS THE END OF RFQ PC07 ***** TOTAL: |          |     |        |             |            |        |

SEE REVERSE SIDE FOR TERMS AND CONDITIONS

|           |           |                                   |
|-----------|-----------|-----------------------------------|
| SIGNATURE | TELEPHONE | DATE                              |
| TITLE     | FEIN      | ADDRESS CHANGES TO BE NOTED ABOVE |

WHEN RESPONDING TO RFQ, INSERT NAME AND ADDRESS IN SPACE ABOVE LABELED 'VENDOR'

**2007 FORD CROWN VICTORIA POLICE INTERCEPTOR  
(FULL SIZE, FOUR DOOR, REAR WHEEL DRIVE, PASSENGER CAR)**

The base price bid of the specified vehicle will include all items/features/equipment listed by Ford Motor Company as standard equipment on this vehicle as well as any other "optional" features to be included in BASE VEHICLE COST.

**MODEL:** 2007 Ford Crown Vic Police Interceptor  
**Body Code:** P71  
**Order Code:** 730 A  
**POWERTRAIN:** 3.55 AXLE

**IN ADDITION TO STANDARD EQUIPMENT FOR THIS VEHICLE, EQUIPMENT TO BE INCLUDED IN BASE VEHICLE COST:**

| <b>ITEM</b>                                 | <b>ITEM ORDER CODE #</b> |
|---|--------------------------|
| Lamp Pre-Wire Group:                        | 476                      |
| Grille Lamp, Siren and Speaker Wiring       | 172                      |
| AUDIO, AM/FM Stereo Radio                   | 58F                      |
| Hoses, Silicone w/Aircraft Clamps           | 177                      |
| Lamp, Courtesy Disable                      | 478                      |
| Floor Covering, Carpet & Mats               | 128                      |
| Power Heated Mirrors                        | 61K                      |
| Spotlamp (Driver's Side Only)               | 51A                      |
| Limited Slip Differential                   | 45C                      |
| Seats, Cloth Buckets/Cloth Rear             | H                        |
| Horn/Siren Wiring Prep Package              | 175                      |
| State Police Paint Scheme (see note below)  |                          |
| Moldings, Color Keyed Body Side (Installed) | 96A                      |

WV State Police Custom Paint Scheme – (Vehicles will be purchased from available Ford stock colors for the above described model). All bumper coverings and/or body side moldings are to be of the same color. The vendor will customize the paint scheme by painting the traditional gold portion of the vehicle, which includes the roof of vehicle, front and rear pillars. The exact paint code and pattern may be obtained from the West Virginia State Police Procurement Section, Attention, 1<sup>st</sup>. Sgt Rick Pursley (Phone-746-2238) prior to bid submission:

**IMPORTANT NOTE:** Prospective Vendors must include all profit margins for the vehicle bid in the "Base Vehicle Cost" below. For bidding purposes, all options listed above must be included in the "Base Vehicle Cost."

**Base Vehicle Cost:**

\$ NO BID

2007 CHEVROLET IMPALA POLICE PURSUIT VEHICLE  
(MID-SIZE, FOUR DOOR, FRONT WHEEL DRIVE)

The base price bid of the specified vehicle will include all items/features/equipment listed by Chevrolet as standard equipment, as well as any other "optional" features listed below under Mandatory Equipment Base Package. These features include:

**MODEL:** 2007 Chevrolet Impala 4 – Door Sedan  
**Order Code:** 9C1

**Mandatory Equipment Base Package:**

Air Conditioning: Installed  
Locks: Power with rear door child security  
Radio: AM/FM/Cassette with Clock  
Steering: Power, with Tilt Wheel  
Wipers: Intermittent with high speed Anti-lift Wipers System on Driverside  
Brakes: 4 Wheel Anti-Lock disc brakes with Police Calibration and Heavy duty front brake pads  
Suspension: Heavy Duty Police, Front & Rear Stabilizer Bars  
Transmission: Heavy Duty, 4T65E 4-Speed Automatic, with Oil Cooler  
Engine: Chevrolet 3900 Series II SFI V-6  
Cooling: Heavy/Severe Duty, High Capacity  
Engine Cradle: Reinforced  
Front Struts: Reinforced  
Alternator: 150 AMP with Idle Boost  
Battery: Heavy Duty  
Tires: P225/60R 16 SBR Blackwall "V" rated .  
Wheels/Covers: 16 " x 6.5" heavy duty steel wheels, with chrome bolt on wheel center caps  
Spare Tire: (N81) Full Size  
Seats -- Front: Heavy duty cloth front bucket seats with ANO CONSOLE@ between the seats  
Seats -- Rear: Cloth Bench  
Speedometer: Certified calibrated speedometer  
Key: Single key for all locks, each vehicle different  
Defogger: Rear Window Installed  
License Bracket: Front & Rear  
Dome Lamp: Door switch deactivated  
Electric Mirrors: LH & RH Remote Installed  
Windows: Power with Rear Window lockout switch, Factory Installed  
Floor Covering: Full carpeting to include a complete set of four, color- coordinated factory floor mats  
Trunk Release: Electric  
Dome Lamp (C67): Front Aux.  
State Police Paint Scheme

WV State Police Custom Paint Scheme – (Vehicles will be purchased from available Chevrolet stock colors for the above described model). All bumper coverings and/or body side moldings are to be of the same color. The vendor will customize the paint scheme by painting the traditional gold portion of the vehicle, which includes the roof of vehicle, front and rear pillars. The exact paint code and pattern may be obtained from the West Virginia State Police Procurement Section, Attention, 1<sup>st</sup> Sgt. Rick Pursley(Phone 304-746-2238) prior to bid submission:

**NO BID**



Don McNemar  
COUNTRY CLUB CHRYSLER DODGE  
PO Box 2321 - US Rt 19 S.  
Clarksburg, WV 26302-2321  
800-424-7611 FAX 304-624-5428

2007 DODGE CHARGER POLICE PURSUIT VEHICLE  
(MID-SIZE, FOUR DOOR, REAR WHEEL DRIVE)

The base price bid of the specified vehicle will include all items/features/equipment listed by Dodge as standard equipment, as well as any other "optional" features listed below under Mandatory Equipment Base Package. These features include:

**MODEL:** 2007 Dodge Charger- 4 door Sedan  
**Order Code:**

**Mandatory Equipment Base Package:**

|                   |  |
|-------------------|--|
| Air Conditioning: | Installed  |
| Locks:            | Power with rear door child security  |
| Radio:            | AM/FM/Cassette with Clock  |
| Steering:         | Power, with Tilt Wheel   |
| Wipers:           | Intermittent with high speed Anti-lift Wipers System on Driver side                    |
| Brakes:           | 4 Wheel Anti-Lock disc brakes with Police Calibration and Heavy duty front brake pads. |
| Suspension:       |  |
| Transmission:     | Five-Speed automatic transmission with overdrive plus autostick (column shifter)       |
| Engine:           | 3.5 Liter V-6 engine   |
| Cooling:          | Severe Duty Cooling System   |
| Engine Cradle:    | Reinforced   |
| Front Struts:     | Reinforced   |
| Alternator:       | 160-Amp high-output alternator   |
| Battery:          | Heavy Duty   |
| Tires:            | P225/60R18 BSW V-Rated performance tires   |
| Wheels/Covers:    | 18 x 7.5 inch steel wheels with standard Dodge Wheel Covers.                           |
| Spare Tire:       | Full   |
| Seats-Front:      | Heavy-duty cloth front bucket seats with manual lumbar .                               |
| Seats-Rear:       | Cloth Bench.   |
| Speedometer:      | 160-mph certified calibrated speedometer.  |
| Key:              | Separate key and key fob   |
| Defogger:         | Rear Window installed.   |
| License Bracket:  | Front and rear   |
| Dome Light:       | Door Switch Deactivated  |
| Electric Mirrors: | LH & RH Remote installed   |
| Windows:          | Power with drivers' one touchdown feature  |
| Floor Covering:   | Full Carpeting to include a set of four, color-coordinated factory floor mats          |
| Trunk Release:    | Electric   |
| Dome Lamp ( )     | Front Aux.   |

Police Equipment Mounting Bracket:            Installed

State Police Paint Scheme:

WV State Police Custom Paint Scheme- (Vehicles will be purchased from available Dodge stock colors for the above described models). All bumper coverings and/or body side moldings are to be the same color. The vendor will customize the paint scheme by painting the traditional gold portion of the vehicle, which includes the roof of vehicle, front and rear pillars. The exact paint code and pattern may be obtained from the West Virginia State Police –Procurement Section, Attention 1<sup>st</sup> Sgt. Rick Pursley, (Phone 304-746-2238) prior to bid submission.

**IMPORTANT NOTE:** Prospective Vendors must include all profit margins for the vehicle bid in the “Base Vehicle Cost” below. Any and all options must be made available at actual Dealer Cost ( the below listing is not-all inclusive). Pricing for all options listed below must be provided with the bid package. Failure to provide option-pricing information (at dealer cost) shall be grounds for disqualification of the bid. For bidding purposes, all options listed above must be included in the “Base Vehicle Cost”

**BASE VEHICLE COST:**

**\$ 18,921.00**

**End of Base Vehicle Cost**

**OPTION PRICING INFORMATION:**

|   |          |          |
|---|----------|----------|
| 5.7L Hemi V8 with Mult-Displacement System and 340 hp, 390 lb-ft torque@ 400 RPM. | 2,972.00 | \$ _____ |
| Cruise Control (    )   | STANDARD | \$ _____ |
| Seat-Front-substitute vinyl for cloth   | N/A      | \$ _____ |
| Seat-Rear-substitute vinyl for cloth  | 110.00   | \$ _____ |
| Floor Covering-substitute heavy duty black Vinyl for carpet (    )                | 69.00    | \$ _____ |
|   | 184.00   |          |
| Spotlight-Left hand drivers side  |          | \$ _____ |

|  |                             |
|--|-----------------------------|
| Service Manuals (one set) (complete Set of "dealer" shop manuals, inclusive of any future updates) | \$ <u>85.00 CD ONLY</u>     |
| Mats, Front and Rear ( )   | \$ <u>STANDARD</u>          |
| All Vehicles Keyed Alike:  | \$ <u>37.00</u>             |
| Spare Tire-Full Size (credit)  | \$ <u>-142.00</u>           |
| Traction Control   | \$ <u>STANDARD</u>          |
| Switchable Daytime Running Lights  | \$ <u>37.00</u>             |
| Auxiliary wiring battery ignition feed to The front passenger floor/dash area                      | \$ <u>STANDARD</u>          |
| Grounding Stud located in trunk  | \$ <u>STANDARD</u>          |
| Wiring for alternating lamps (Wig Wag)   | \$ <u>STANDARD</u>          |
| Power Drivers Seat   | \$ <u>350.00</u>            |
| Shift Lever ( )  | \$ <u>COLUMN MOUNT ONLY</u> |
| West Virginia State Police custom paint Scheme (credit)  | \$ <u>-168.00</u>           |

Exterior Color Pricing:

**SEE ATTACHED OPTION SHEET**

**Important Note:** The above specified base vehicle cost for vehicles painted "standard factor colors" (no two tone).

The base price quoted above is for any of the specified "standard factor colors" and must include color keyed // matching body trim and bumper covering, if available.

The below listed paint schemes are optional and shall be priced as indicated:

Standard Factory Color in  
Two-Tone Paint Scheme: \$ NOT AVAILABLE

If minimum order quantity required for Special Police Paint Schemes, specify here:

Minimum # **NOT AVAILABLE AT THIS TIME**  
**POSSIBILITY AT LATER DATE**

# PC07 DODGE CHARGER

## ADDITIONAL 2007 CHARGER OPTION'S

|   | COST     |
|---|----------|
| 18" FULL FACE BOLT ON WHEEL COVERS                              | \$28.00  |
| DEACTIVATE REAR DOORS & WINDOWS                                 | \$23.00  |
| DISABLES LEVERS & SWITCHES RELOCATES DOOR LOCKS                 |          |
| FACTORY FOG LIGHT NOT AVAILABLE FROM FACTORY [DEALER INSTALLED] | \$193.00 |
| WIRING ADAPTER KIT DEALER PARTS ONLY                            | \$10.27  |

## DODGE MAGNUM OPTION ADD ON TO BASE CHARGER PRICE

|                               |            |
|-------------------------------|------------|
| V-6 3.5L POLICE UNIT          | \$1,488.00 |
| V-8 5.7L MDS HEMI POLICE UNIT | \$4,552.00 |
| CARGO COMPARTMENT COVER       | \$69.00    |
| REAR CARGO ORGANIZER          | \$147.00   |

## STANDARD COLORS----- ALL MODELS

BRIGHT SILVER  
BRILIANT BLACK  
MARINE BLUE  
SLIVER STEEL  
STEEL BLUE  
STONE WHITE

## OPTIONAL COLOR

INFERNO RED \$207.00

## INTERIOR COLOR

DK/LT SLATE GRAY - - - ONLY

DON McNEMAR  
COUNTRY CLUB CHRYSLER DODGE INC  
PO BOX 2321  
CLARKSBURG, WV 26302  
304-624-7611 800-424-7611  
FAX 304-624-5428  
CELL-304-669-0192  
E-MAIL [businesslink@countryclubchrysler.com](mailto:businesslink@countryclubchrysler.com)

# AFFIDAVIT

**West Virginia Code §5A-3-10a states:**

No contract or renewal of any contract may be awarded by the state or any of its political subdivisions to any vendor or prospective vendor when the vendor or prospective vendor or a related party to the vendor or prospective vendor is a debtor and the debt owned is an amount greater than one thousand dollars in the aggregate.

**DEFINITIONS:**

"Debt" means any assessment, premium, penalty, fine, tax or other amount of money owed to the state or any of its political subdivisions because of a judgment, fine, permit violation, license assessment, defaulted workers' compensation premium, penalty or other assessment presently delinquent or due and required to be paid to the state or any of its political subdivisions, including any interest or additional penalties accrued thereon.

"Debtor" means any individual, corporation, partnership, association, limited liability company or any other form or business association owing a debt to the state or any of its political subdivisions.

"Political subdivision" means any county commission; municipality; county board of education; any instrumentality established by a county or municipality; any separate corporation or instrumentality established by one or more counties or municipalities, as permitted by law; or any public body charged by law with the performance of a government function or whose jurisdiction is coextensive with one or more counties or municipalities.

"Related party" means a party, whether an individual, corporation, partnership, association, limited liability company or any other form or business association or other entity whatsoever, related to any vendor by blood, marriage, ownership or contract through which the party has a relationship of ownership or other interest with the vendor so that the party will actually or by effect receive or control a portion of the benefit, profit or other consideration from performance of a vendor contract with the party receiving an amount that meets or exceeds five percent of the total contract amount.

**EXCEPTION:**

The prohibition of this section does not apply where a vendor has contested any tax administered pursuant to chapter eleven of this code, workers' compensation premium, permit fee or environmental fee or assessment and the matter has not become final or where the vendor has entered into a payment plan or agreement and the vendor is not in default of any of the provisions of such plan or agreement.

**LICENSING:**

The vendor must be licensed in accordance with any and all state requirements to do business with the state of West Virginia.

**CONFIDENTIALITY:**

The vendor agrees that he or she will not disclose to anyone, directly or indirectly, any such personally identifiable information or other confidential information gained from the agency, unless the individual who is the subject of the information consents to the disclosure in writing or the disclosure is made pursuant to the agency's policies, procedures and rules. Vendors should visit [www.state.wv.us/admin/purchase/privacy](http://www.state.wv.us/admin/purchase/privacy) for the Notice of Agency Confidentiality Policies.

Under penalty of law for false swearing (West Virginia Code, §61-5-3), it is hereby certified that the vendor acknowledges the information in this said affidavit and are in compliance with the requirements as stated.

**COUNTRY CLUB CHRYSLER DODGE INC.**

Vendor's Name: \_\_\_\_\_  
 Authorized Signature:  Date: OCTOBER 11, 2006



State of West Virginia  
 Department of Administration  
 Purchasing Division  
 2019 Washington Street East  
 Post Office Box 50130  
 Charleston, WV 25305-0130

**Request for  
 Quotation**

RFQ NUMBER  
 PC07

PAGE  
 1

ADDRESS CORRESPONDENCE TO ATTENTION OF  
 BETTY FRANCISCO  
 304-558-0468

**COUNTRY CLUB CHRYSLER  
 DODGE SPRINTER  
 PO BOX 2321  
 CLARKSBURG, WV 26302-2321**

ALL STATE AGENCIES  
 AND POLITICAL SUBDIVISIONS  
 VARIOUS LOCALES AS INDICATED  
 BY ORDER

|                            |               |          |        |               |
|----------------------------|---------------|----------|--------|---------------|
| DATE PRINTED<br>09/22/2006 | TERMS OF SALE | SHIP VIA | F.O.B. | FREIGHT TERMS |
|----------------------------|---------------|----------|--------|---------------|

BID OPENING DATE: 10/11/2006 BID OPENING TIME 01:30PM

| LINE   | QUANTITY | UOP | CAT NO | ITEM NUMBER | UNIT PRICE | AMOUNT |
|--|----------|-----|--------|-------------|------------|--------|
| ADDENDUM NO. 01  |          |     |        |             |            |        |
| 1. THE BID OPENING DATE HAS BEEN MOVED TO WEDNESDAY, OCTOBER 11, 2006, AT 1:30 P.M.  |          |     |        |             |            |        |
| 2. RICK PURSLEY WILL BE AVAILABLE ON OR AFTER OCTOBER 8, 2006 FOR INFORMATION ON THE PAINT CODE AND PATTERN - TELEPHONE NUMBER 304-746-2238. |          |     |        |             |            |        |
| *****END OF ADDENDUM NO. 01*****   |          |     |        |             |            |        |

|   |                           |                                   |  |
|---|---------------------------|-----------------------------------|--|
| SEE REVERSE SIDE FOR TERMS AND CONDITIONS |                           |                                   |  |
| SIGNATURE<br><i>[Signature]</i>           | TELEPHONE<br>304-624-7611 | DATE<br>10-11-06                  |  |
| TITLE<br>Fleet Manager                    | FERN<br>550562249         | ADDRESS CHANGES TO BE NOTED ABOVE |  |

WHEN RESPONDING TO RFQ, INSERT NAME AND ADDRESS IN SPACE ABOVE LABELED 'VENDOR'



State of West Virginia  
 Department of Administration  
 Purchasing Division  
 2019 Washington Street East  
 Post Office Box 50130  
 Charleston, WV 25305-0130

# Request for Quotation

|            |      |
|------------|------|
| RFQ NUMBER | PC07 |
|------------|------|

|      |   |
|------|---|
| PAGE | 1 |
|------|---|

|   |
|---|
| ADDRESS CORRESPONDENCE TO ATTENTION OF: |
| BETTY FRANCISCO<br>304-558-0468         |

VENDOR

Don McNemar  
 Country Club Chrysler Plymouth Dodge  
 P. O. Box 2321  
 Route 19 South  
 Clarksburg, WV 26302-2321

SHIP TO

ALL STATE AGENCIES  
 AND POLITICAL SUBDIVISIONS  
 VARIOUS LOCALES AS INDICATED  
 BY ORDER

|                              |               |                          |        |               |
|------------------------------|---------------|--------------------------|--------|---------------|
| DATE PRINTED                 | TERMS OF SALE | SHIP VIA                 | F.O.B. | FREIGHT TERMS |
| 10/04/2006                   |               |                          |        |               |
| BID OPENING DATE: 10/11/2006 |               | BID OPENING TIME 01:30PM |        |               |

| LINE  | QUANTITY | UOP | CAT. NO. | ITEM NUMBER | UNIT PRICE | AMOUNT |
|---|----------|-----|----------|-------------|------------|--------|
| ADDENDUM NO. 02   |          |     |          |             |            |        |
| SEE THE ATTACHED FOR THE SPECIAL GOLD PAINT MIX INSTRUCTIONS FOR THE GOLD TOPS OF THE CRUISERS. |          |     |          |             |            |        |
| *****END OF ADDENDUM NO. 02*****  |          |     |          |             |            |        |

|                              |  |  |                |   |  |                                   |  |               |  |
|------------------------------|--|--|----------------|---|--|-----------------------------------|--|---------------|--|
| SIGNATURE <i>Don McNemar</i> |  |  |                | SEE REVERSE SIDE FOR TERMS AND CONDITIONS |  | TELEPHONE 304-624-7611            |  | DATE 10-11-06 |  |
| TITLE FLEET MANAGER          |  |  | FEIN 550567749 |   |  | ADDRESS CHANGES TO BE NOTED ABOVE |  |               |  |

WHEN RESPONDING TO RFQ, INSERT NAME AND ADDRESS IN SPACE ABOVE LABELED 'VENDOR'



**WEST VIRGINIA STATE POLICE**  
725 Jefferson Road  
South Charleston, West Virginia 25309-1698  
wvstatepolice.com

**Joe Manchin III**  
Governor

MEMORANDUM

**Colonel D. L. Lemmon**  
Superintendent

TO: BETTY FRANCISCO  
WV STATE PURCHASING

FROM: 1<sup>ST</sup> SGT RICK PURSLEY *RP*  
WV STATE POLICE

DATE: OCTOBER 3, 2006

REF: PAINT SCHEME FOR WV STATE POLICE CRUISERS

There have been several inquiries in regards to the gold tops of our cruisers. I have contacted our body shop personnel. The gold pain is a special mix paint. The following is the information that I was provided with in regards to the mix.

| *PPG | *DBU | 1 pint |
|------|------|--------|
| DMD  | 640  | 160.0  |
| PRL  | 97   | 176.0  |
| PRL  | 98   | 186.8  |
| DMD  | 643  | 234.8  |
| DMD  | 648  | 258.8  |
| DMD  | 623  | 266.8  |
| DMD  | 651  | 271.6  |
| DMD  | 695  | 511.6  |

\* (PPG stands for Pittsburg Paint & Glass and DBU is the type of paint which is a base coat/clear coat) RMS is our local paint vendor that we purchase paint from for our State Police Body shop. Their phone # is 346-9661. Please forward this information in the form of an addendum to any interested vendors.



Vendor:

Spending Unit:

Requisition No.: PC 07

ADDENDUM ACKNOWLEDGEMENT

I hereby acknowledge receipt of the following checked addendum(s) and have made the necessary revisions to my proposal, plans and/or specifications, etc.

Addendum No.'s:

No. 1 ✓

No. 2 ✓

No. 3 \_\_\_\_\_

No. 4 \_\_\_\_\_

No. 5 \_\_\_\_\_

I understand that failure to confirm the receipt of the addendum(s) is cause for rejection of bids.



Signature

COUNTRY CLUB CHRYSLER DODGE INC

Company

10-11-06

Date

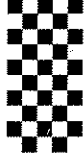

# PC07

**2007 SPORT UTILITY VEHICLE DODGE DURANGO, FORD-  
EXPLORER, JEEP GRAND CHEROKEE (FULL SIZE, FOUR DOOR,  
FOUR WHEEL DRIVE, UTILITY VEHICLE)**

COUNTRY CLUB CHRYSLER DODGE  
PO BOX 2521  
CHARLESTON, WV 26032  
800-424-7611 304-624-7611  
FAX 304-624-5428  
E-MAIL  
businessclubs@countryclubchrysler.com

Vehicles bid in this classification shall be full-size, four door vehicles commonly referred to as sport utility vehicles. In addition to four passenger doors, they must also include a rear lift gate or cargo doors. Any vehicle bid must be able to withstand the rigors of police use and shall meet the following minimum specifications.

The base price bid of the specified vehicle will include all items/features/equipment listed by the manufacturer as standard equipment, as well as any other "optional" features listed below. These features include, but are not limited to the following.

Mandatory Equipment Package:

- Engine: Minimum 4.6 Liter, V8 **4.7 L V-8**
- Wheelbase: Minimum 113"
- Transmission: Automatic, with Heavy Duty Oil Cooler, Maximum Available
- Differential: Limited Slip, Rear **TRACTION CONTROL W/ Electronic Stability**
- Transfer Case: 4 wheel Drive, with no Center Mounted Shifter(s)
- Suspension: Heavy Duty with Front and Rear Stabilizer
- Engine Cooling: Heavy Duty, Maximum Available for Vehicle
- Steering: Power Assisted
- Brakes: Power Assisted / 4 Wheel ABS
- Radio: AM/FM Cassette Stereo **(AM/FM CD - Standard)**
- Front Seats: Cloth, High Back, Bucket Seats
- Rear Seat: Cloth Bench
- Third Seat: None
- Windows: Power Operated
- Door Locks: Power Operated with Rear Child Safety Feature
- Floor Covering: Fully Carpeted Passenger Compartment and Cargo Area with Coordinating Carpeted Floor Mats (4) or Heavy Duty Black Vinyl Floor Covering (If Available with other Equipment Specified)
- Rear Window Defogger: Installed
- Air Conditioning: Installed
- Spare Tire: Full Size
- Skid Plates: Transmission and Transfer Case

-- End of Base Equipment Listing B

**IMPORTANT NOTE:** Prospective Vendors must include all profit margins for the vehicle bid in the "Base Vehicle Cost" specified below. Any and all options must be made available at actual Dealer Cost (the below listing is not all-inclusive). Pricing for all options listed below must be provided with the bid package. Failure to provide option-pricing information (at dealer cost) shall be grounds for disqualification of the bid.

Model: **DODGE DURANGO SXT**

Base Vehicle Cost: **\$ 20,583.00**

**2007 SPORT UTILITY VEHICLE DODGE DURANGO, FORD EXPLORER,  
JEEP GRAND CHEROKEE (FULL SIZE, FOUR DOOR, FOUR WHEEL  
DRIVE, UTILITY VEHICLE)**

**OPTION PRICING INFORMATION:**

Trailer Towing Package:

**\$ INCLUDED WITH STANDARD  
NO COOLING**

Service Manuals (one set)-  
(complete set of "dealer" shop manuals,  
Inclusive of any future updates)

**\$ 85.00 CD ONLY**

| ADDITIONAL OPTIONS:                   |                  |
|---------------------------------------|------------------|
| <b>5.7L MULTI-DISPLACEMENT ENGINE</b> |                  |
| REQUIRES SLT & INCLUDED               | <b>\$3400.00</b> |
| <b>SLT PACKAGE W/ 4.7L ENG</b>        |                  |
|                                       | <b>\$2377.00</b> |
| <b>2 SPEEDTRANSFER CASE</b>           | <b>\$168.00</b>  |
| <b>GRAY RUNNING BOARDS</b>            | <b>\$338.00</b>  |

Miscellaneous: Inspection of Sample Vehicle(s): Within one week after the issuance of a purchase order, the successful bidder shall make arrangements to deliver to the West Virginia State Police, 725 Jefferson Road, South Charleston, West Virginia, a sample vehicle having the same general body, chassis, engine and transmission as the vehicle on which the bid was submitted. This vehicle is not a patrol vehicle and may be a vehicle from the dealer's stock. It will be used as a prototype for determining the method of attaching various items of police equipment.

The standard factory warranty of the vehicle bid shall be clearly specified within the body of the Vendor's bid submission. In addition, any available extended factory warranties which are optional shall also be bid as separate items, listing all areas and items covered.

Note: Equipment installation to be at the factory and not "add on" dealer accessories. Any exception(s) will be clearly stated within the body of the respective Vendor's bid submission.

**Inspection, Testing and Evaluation -- State Police Vehicle Only .**

Pre-Delivery: Prior to delivery, each, new vehicle must be completely serviced in accordance with standard new car dealer "make ready" preparation and in accordance with these specifications and the manufacturer's recommendations. Crankcase, differential, transmissions and fuel tank must be filled to capacity as recommended by the manufacturer. Each vehicle shall contain a pre-delivery check sheet showing what operations have been performed on the vehicle and signed by the mechanic(s) or individuals that worked on the same prior to the department inspection.

Delivery, Testing and Evaluation: Vehicles will be inspected, tested and evaluated to determine if they meet the requirements of this specification.

Vehicles will be delivered by the dealer. (Vehicles purchased by the West Virginia State Police will be delivered to 725 Jefferson Road, South Charleston, West Virginia.) Vehicles will not be accepted until inspected and approved by the Purchaser. All repairs and corrections will be the responsibility of the dealer. Dealer will provide dealer's license, insurance (as required for dealer license), and reasonable management assistance for pre-delivery acceptance inspections. If the successful bidder's car does not meet the requirements of this specification, it will be rejected.



# Chrysler Group Police Vehicles

## The New Force in Law Enforcement

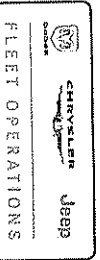
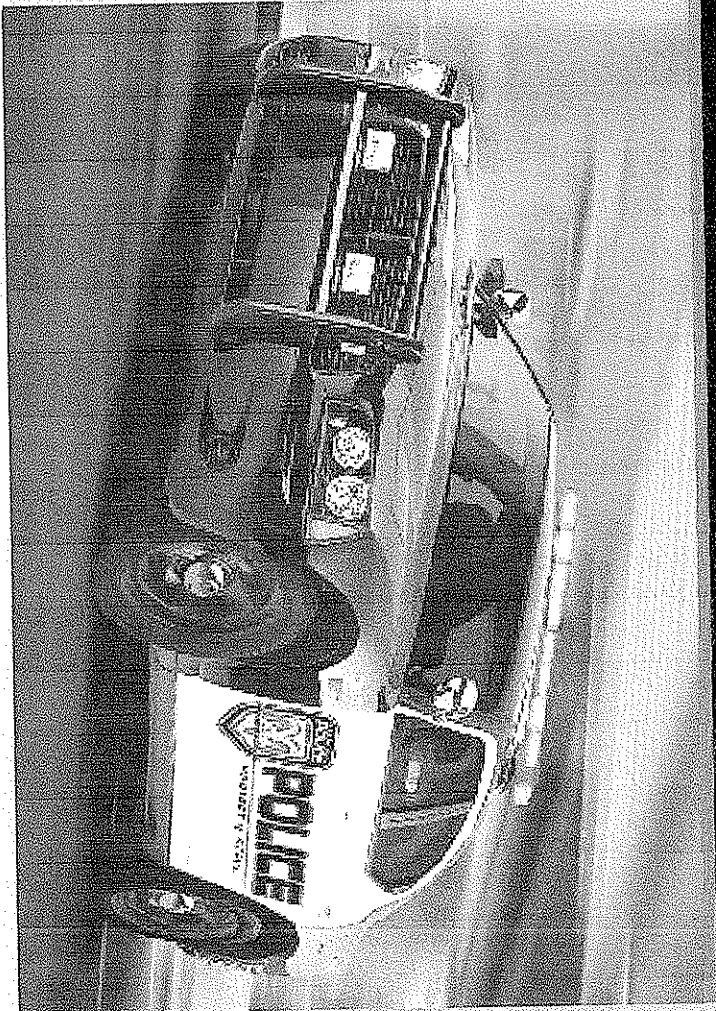

THE BRANDS THAT DRIVE BUSINESS™

## Our Lineup for Your Lineup

The needs of police departments vary, which is why we offer a range of police vehicles, including our newest offering — Dodge Charger, available for pursuit or patrol. Also available for both purposes is Dodge Magnum. Parking enforcement duties are expertly handled by the GEM Security Vehicle — an electric car that exceeds federal regulations for low-speed vehicles.

As you'll discover throughout this brochure, each is ideally suited for the various needs of police departments everywhere.



NOTE: All vehicles shown in this brochure feature optional aftermarket uplift accessories.



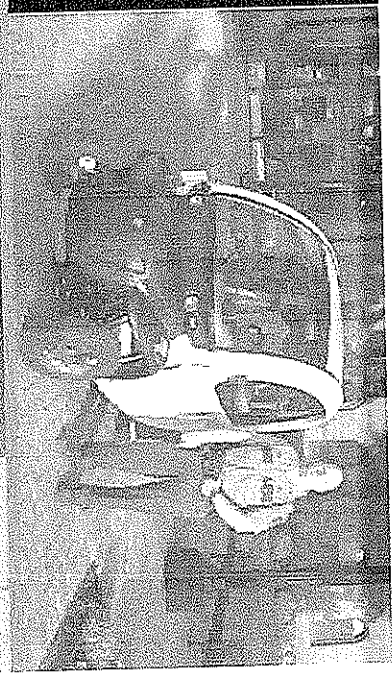

## Dodge Charger: A Special Vehicle for Law Enforcement Needs

What makes a great cop car? Performance, innovation, safety and upfit adaptability. Plus, it must be durable and designed from inception with the needs of police officers in mind.

### **Standard Muscle**

Dodge Charger's standard engine is the 250-horsepower 3.5-liter High Output V6. It delivers 250 lb-ft of torque and impressive EPA fuel economy estimates: 19 mpg in the city, 27 mpg on the highway.

### **Best-in-Class Brawn**

Charger offers the optional best-in-class 5.7-liter HEMI® V8 engine (340 horsepower, 390 lb-ft of torque). It features a Multi-Displacement System, or MDS, which provides better fuel economy by deactivating four of the eight cylinders when less power is needed while cruising. This increases the HEMI V8's fuel economy from 5 percent to 11 percent, depending on driving habits, resulting in an average 17 mpg in the city and 25 mpg on the highway (EPA estimate). The system functions so smoothly, drivers won't notice when four of the cylinders are deactivated and they'll always have the power of a V8 when needed.

### **Best-in-Class Transmission**

Both the standard V6 and the optional HEMI V8 have been paired with a five-speed AutoStick® transmission.

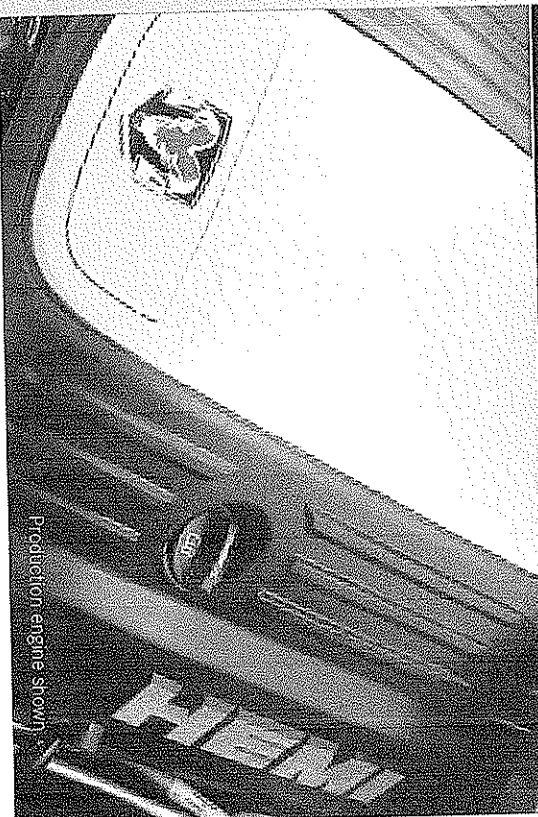
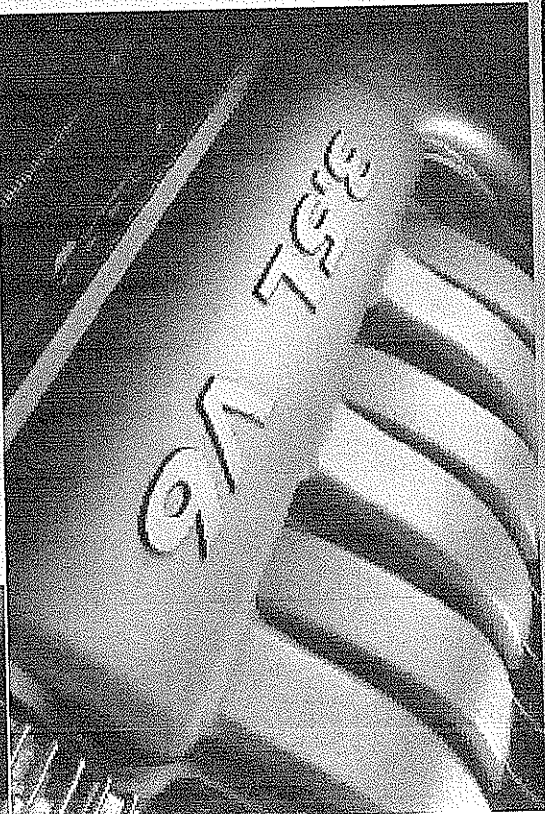

Production engine shown



**Best-In-Class Performance**

Results from 2005 Michigan State Police vehicle testing rated the Dodge Charger, with the HEMI® V8, the highest in several categories, including:

- \* Acceleration — from 0 to 100 mph in 16.2 seconds
- \* Top speed — over 145 mph. A high-speed engine controller electronically limits the vehicle's top speed

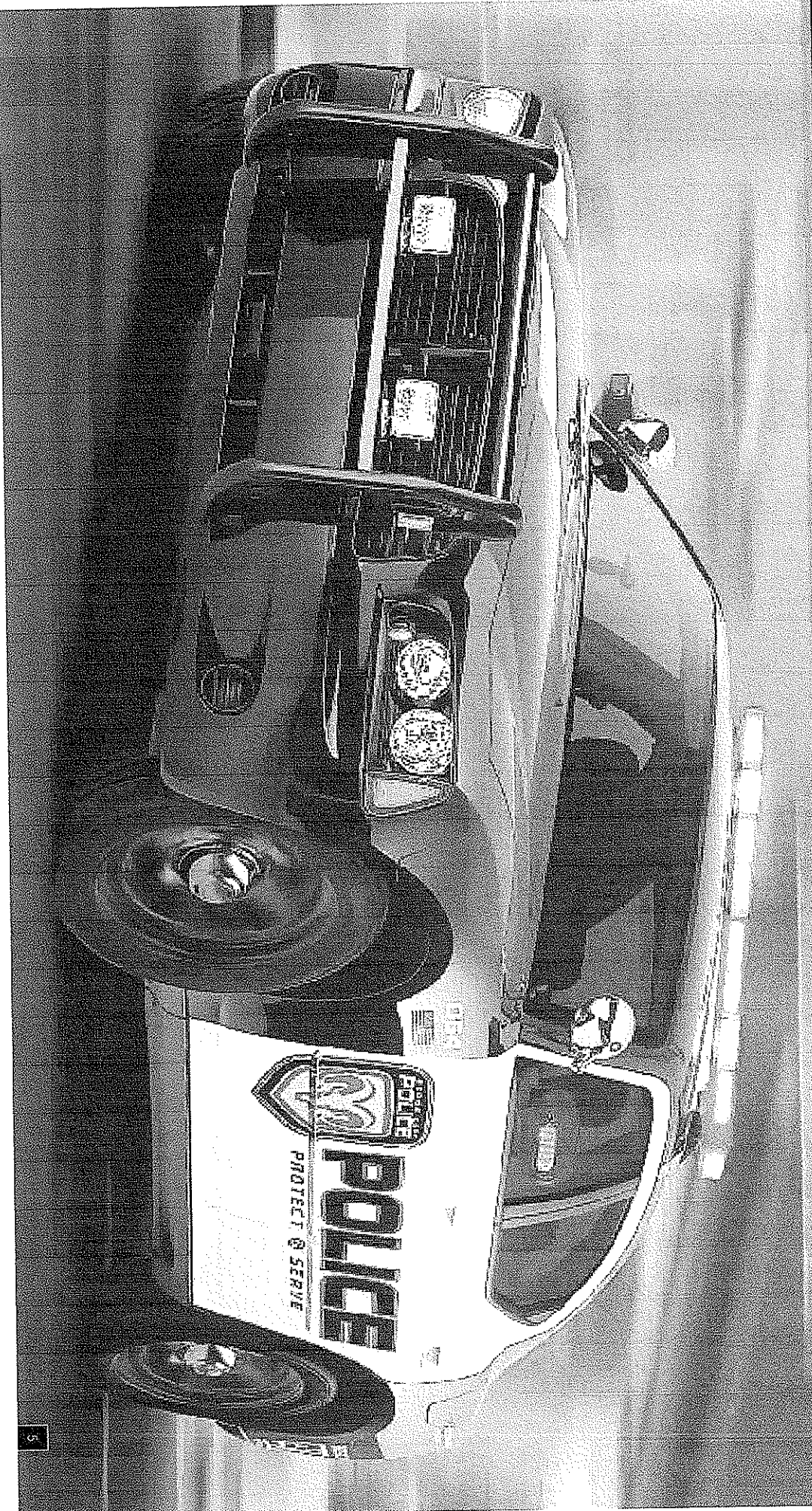



# Dodge Charger: Taking Control at All Times

## Police-Specific ESP

For maximum vehicle control, the Dodge Charger Police Vehicle is equipped with our exclusive Electronic Stability Program<sup>(1)</sup> (ESP), which has been specifically calibrated for police use. It electronically detects and automatically assists drivers in critical driving situations, including adverse conditions.

### ESP Components:

- Antilock Brake System (ABS)
- All-Speed Traction Control
- Yaw Sensor
- Steering Angle Sensor

ESP technology works by constantly comparing the driver's intended course with the vehicle's actual course, detecting differences, applying the brakes to individual wheels and controlling engine power to help keep the vehicle on its intended path.

For example, in the event the vehicle understeers, ESP automatically applies the inside rear brake to help the driver achieve the desired turn. It may also reduce engine power.

The opposite occurs when a vehicle oversteers. ESP automatically applies the outside front brake to help correct the oversteer or "fishtail" situation.

(1) No system, no matter how sophisticated, can repeal the laws of physics or overcome careless driving actions. Performance is limited by available traction, which snow, ice and other conditions can affect. When the ESP warning lamp in the speedometer flashes, the driver needs to use less throttle and adapt speed and driving behavior to prevailing road conditions. Always drive carefully, consistent with conditions. Please always wear your seat belt.

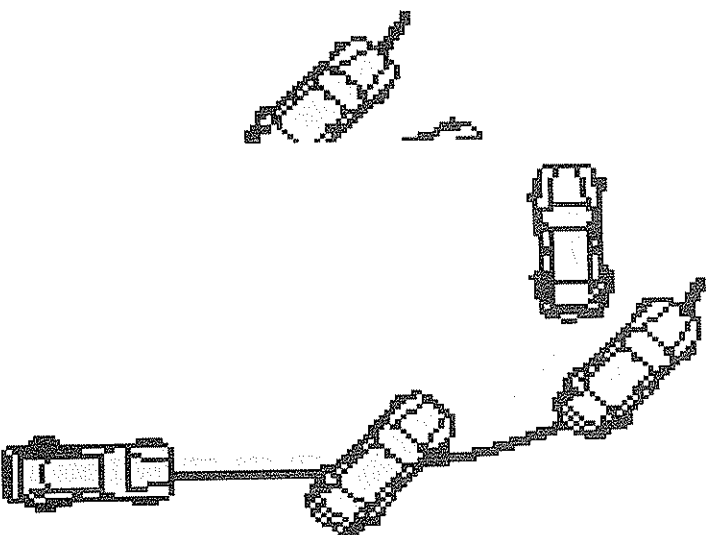

**Standard ESP — One of a Kind**  
Charger is the only police vehicle with standard ESP with three different modes. A study conducted by the National Highway Traffic Safety Administration (NHTSA) shows that electronic stability control, our ESP system, reduced single-vehicle crash risk for cars by 35 percent.

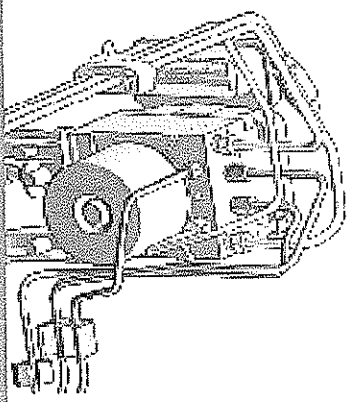

### Three Levels of Stability

The special police version of ESP found on Charger and Magnum operates in three different modes:

- **ESP On** offers fully enhanced vehicle stability
- **Partial Off** turns the system partially off, modifying ESP thresholds and disabling traction control at low speeds
- **Full Off** works the same as **Partial Off**, however the ESP function is turned completely off

In all modes, ABS and Brake Assist are not affected.

ESP works in concert with the vehicle's brake system, which includes heavy-duty, four-wheel disc antilock brakes and Brake Assist — all standard and all designed to deliver maximum braking power.



# Dodge Charger: Engineered to Handle the Way You Drive

## Police-Specific Brake System

For quicker stopping power, Charger is equipped with an impressive brake system that is unique to police vehicles and includes:

- High-performance brake pads — front and rear
- Heavy-duty four-wheel disc brakes with ABS
- 13.6x1.1-inch vented front rotors
- 13.8x1.0-inch vented rear rotors
- Modified rear caliper
- Larger master cylinder

The standard antilock brake system — with unique ABS calibration — increases vehicle control and stability under extreme braking conditions. Charger is also equipped with Brake Assist. This standard feature helps apply maximum braking power in emergency situations.

## Steering/Suspension

Dodge Charger features performance-tuned steering that really excels at high speeds, as well as a heavy-duty, performance-tuned suspension that incorporates rear load leveling and height control to handle bigger cargo loads. Charger is also the only rear-wheel-drive police vehicle with a standard short/long arm front suspension and a five-link rear suspension, providing high-performance handling, optimal ride comfort and maximum traction.

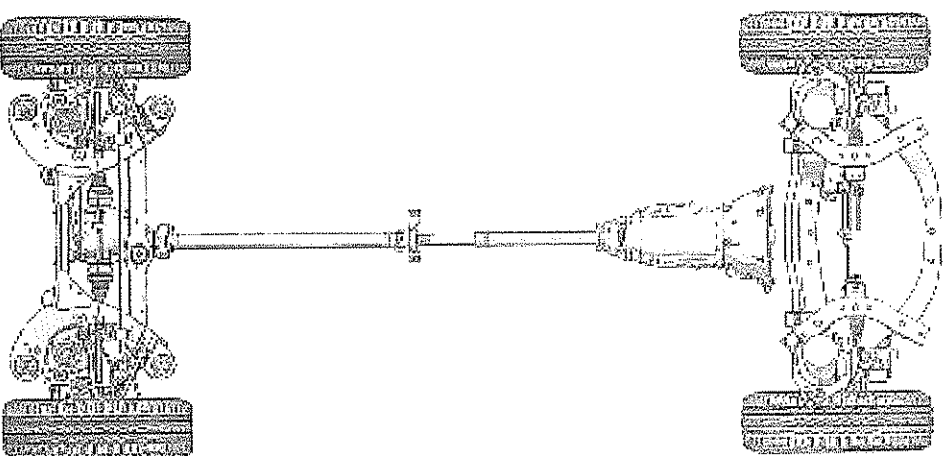



### Best-in-Class Braking and Handling

According to 2005 Michigan State Police vehicle testing, Dodge Charger delivers best-in-class braking power — 60-0 mph in 130.1 feet (projected stopping distance). And according to 2005 Los Angeles County Police testing, Dodge Magnum and Dodge Charger took first and second place in the handling phase, as well as top honors in brake testing, pursuit and acceleration.

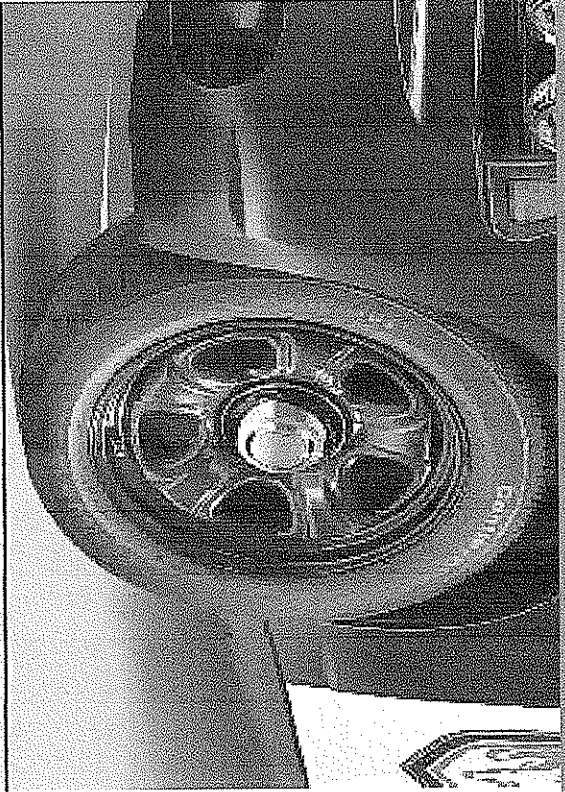

### Tires/Wheelbase

Handling, ride comfort and traction are further accentuated by Charger's standard 18-inch heavy-duty steel wheels and P225/60R18 all-season performance tires — the largest offered on a police car.

Dodge Charger has the longest wheelbase in its class — 120 inches. It also has a nearly 50/50 front-to-rear weight distribution for improved balance and traction. Its "wheels-to-the-corners" design and wider track provide greater stability and improved handling.

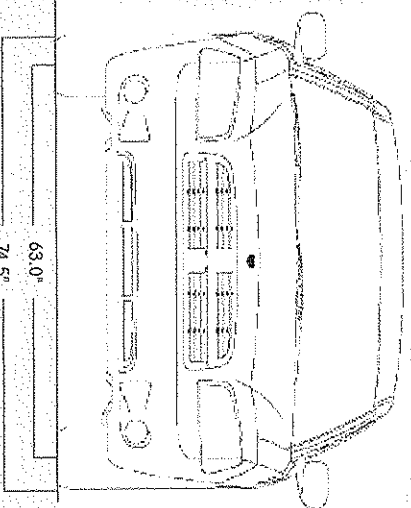
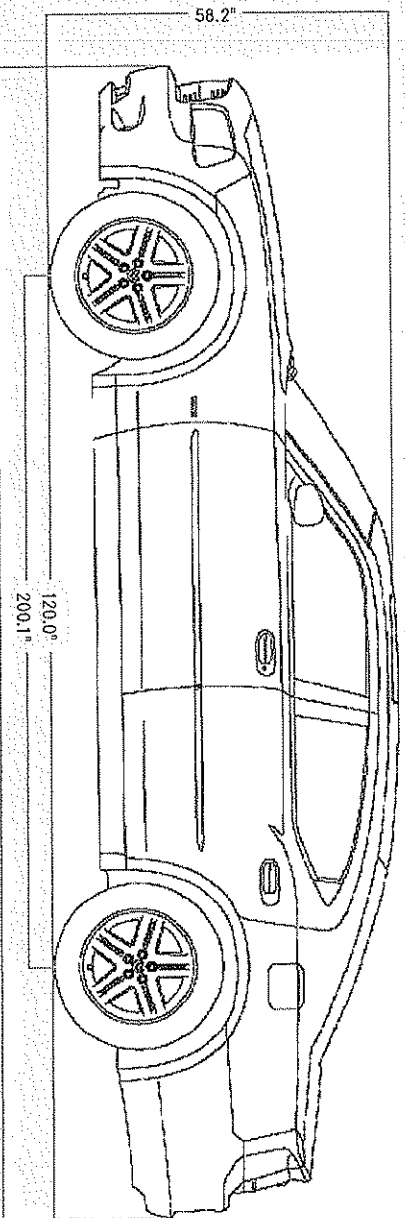
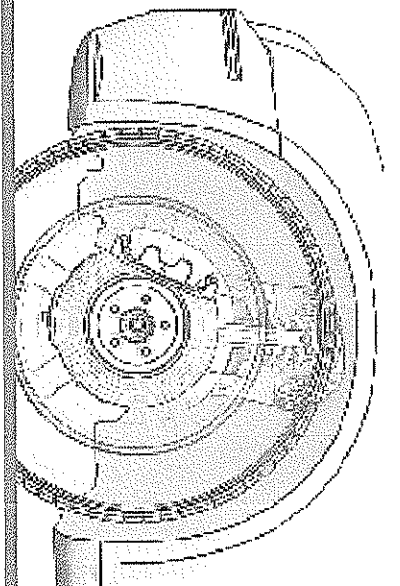

# Dodge Charger. Designed with Police Officers in Mind

## Outstanding Safety Features

Dodge Charger has earned five stars, the highest frontal crash test rating, from NHTSA. This outstanding rating results from Charger's rigid Unibody steel construction, a structure that provides solid occupant protection. Three distinct front crush zones absorb and direct-impact energy away from the passenger compartment.

## Front and Supplemental Side Air Bags

To protect officers inside the vehicle, multistage driver and front-passenger air bags are standard.<sup>(1)</sup>

Supplemental side-curtain air bags are available and provide an additional level of protection from side impacts. They may not be compatible with the prisoner partition.

Charger is equipped with a saddlebag fuel tank that is mounted forward of the rear axle.

<sup>(1)</sup> Always use seat belts. Remember, a backseat is the safest place for children 12 and under.

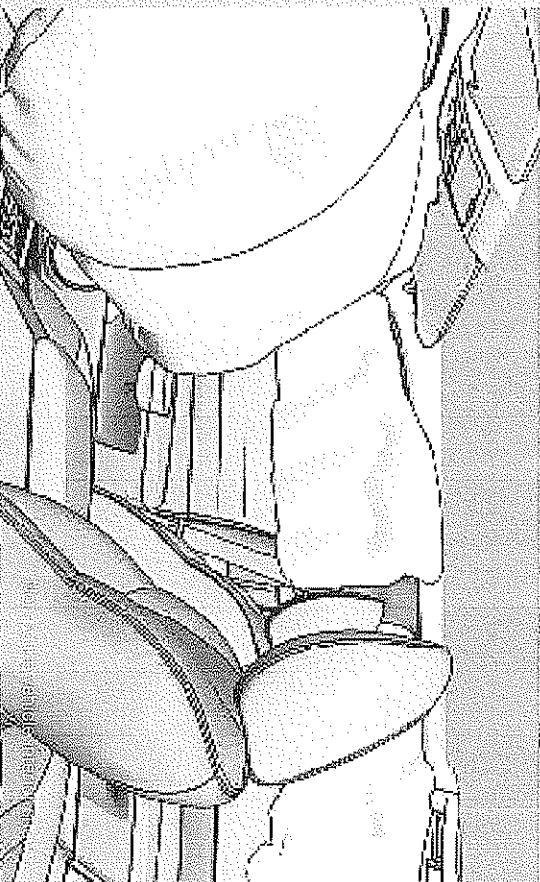
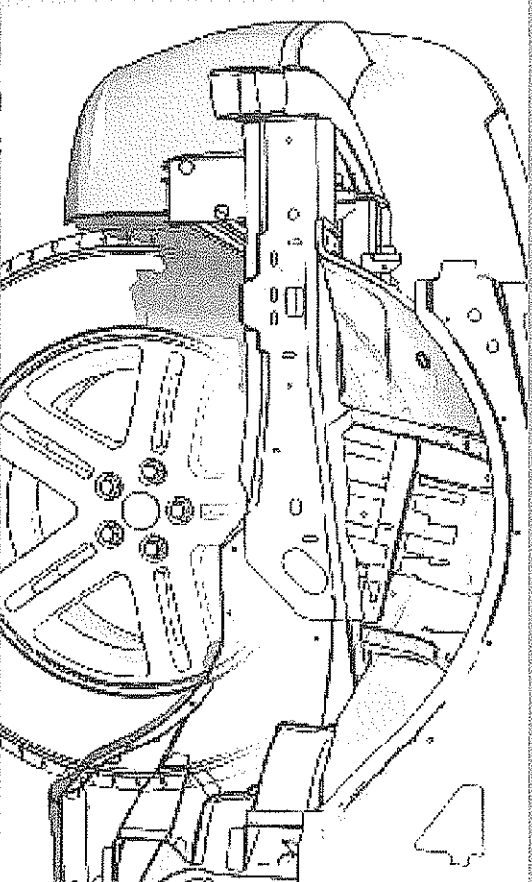

**Best-In-Class Rear-Seat Leg Room**  
Dodge Charger provides more rear-seat leg room than the Ford Crown Victoria or Chevrolet Impala police vehicles.



**Seats**  
Charger's heavy-duty front bucket seats are covered in heavyweight cloth, and the seats' low side bolsters allow enough space for taller, fully equipped officers to comfortably buckle their seat belts over their utility belts.

**Police-Specific Shifter**  
The five-speed automatic transmission shift lever is mounted on the instrument panel to make room for police equipment in the center console area, and to prevent accidental downshifting. When activated, AutoStick® enables police officers to manually select optimal gearing while driving. The standard tilt steering column adjusts easily to the driver's comfort.

**Police Lighting**  
To also help with nighttime activities, the Stealth Mode Switch turns off instrument cluster and radio indicators and dims the PRNDL to the lowest legal level.

**Spacious Trunk**  
When outfitted with the standard compact spare tire, Charger's trunk delivers 16.2 cubic feet of cargo capacity. The optional full-size spare tire mounts above and forward of the compact tire mounting, providing plenty of storage room for police equipment.

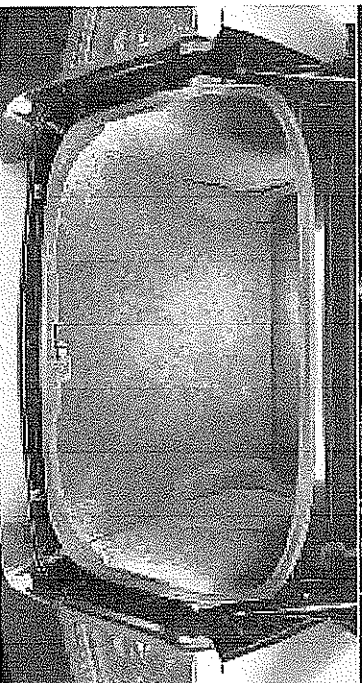



# Dodge Magnum: The Best of Both Worlds

The Dodge Magnum Police Vehicle means police departments no longer have to choose between performance and versatility. Magnum can haul police officers, bad guys and plenty of equipment — up to 27.2 cubic feet with the rear seats up and up to 71.6 cubic feet with the rear seats folded.

## Easy Cargo Access

To facilitate cargo loading, Magnum's rear liftgate opens upward, resulting in a wide, unobstructed, 24-inch by 45.2-inch opening at its widest point ... enabling large, bulky items to be easily accommodated. Magnum is also easier on the back, with a liftover height of just 29.6 inches.

## Commanding Performance

Magnum's performance and versatility are wrapped in a bold exterior style that commands attention ... while moving or standing still. Magnum is powered by the same powertrains found in Charger: the standard 3.5-liter High Output V6 engine and the optional 5.7-liter HEMI® V8 with MDS. Both are paired with a five-speed AutoStick® transmission. (Please refer to page 4.)

## Enhanced Control and Safety

Like Charger, Magnum features the three-level Electronic Stability Program (ESP), four-wheel disc antilock brakes, all-speed traction control, aluminum calipers and Brake Assist. (Please refer to page 6.)

Want more peace of mind? Magnum has earned five stars, the highest frontal crash test rating, from the National Highway Traffic Safety Administration (NHTSA). Magnum also received top honors from the Michigan State Police, braking from 60 to 0 mph in just 128.1 feet.

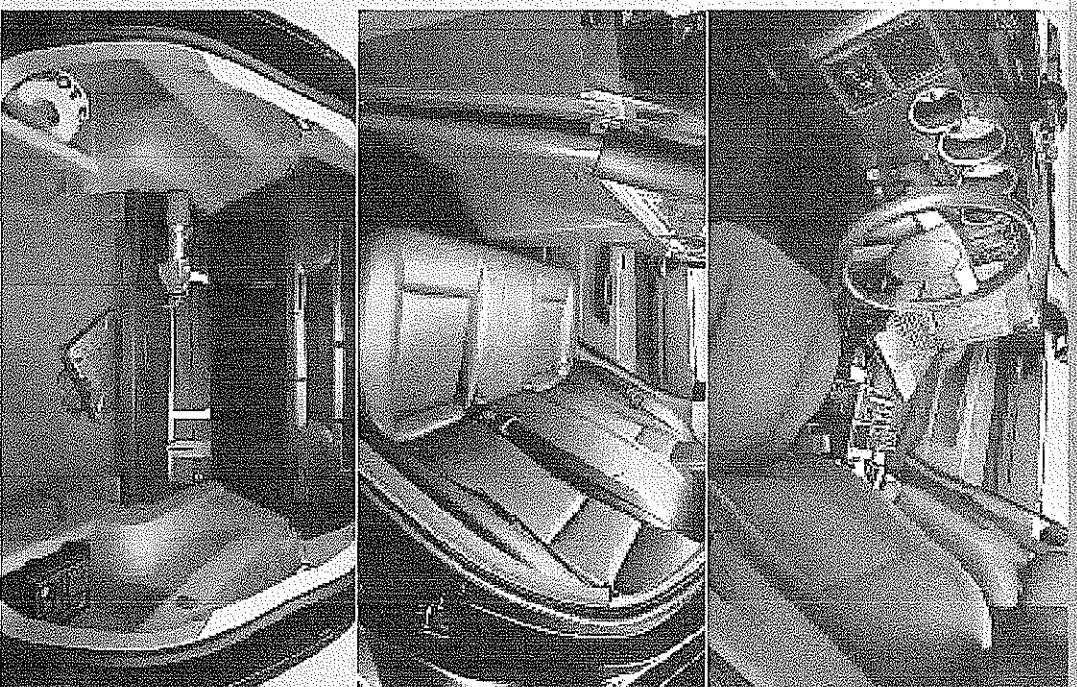

**Best-In-Class Features**

Dodge Magnum Police Vehicle includes a number of best-in-class features:

- \* More cargo room than Crown Victoria or Impala
- \* Faster than Ford Explorer or Ford Expedition
- \* Best overall braking

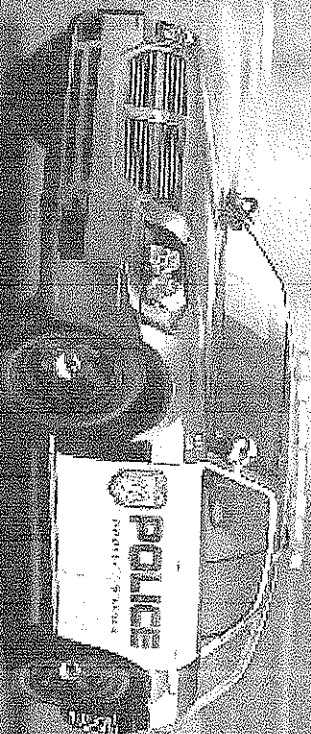



### **Police-Specific Features**

From their inception, Dodge Charger and Magnum Police Vehicles were designed with the needs of law enforcement agencies in mind. Proof can be found in the many features that are exclusive to these vehicles... police-specific features designed to make it easier for your officers to do their jobs while keeping your upfitting costs down.

### **LED Interior Dome Lamp**

Charger and Magnum have an available unique, independently switched red/white LED interior dome lamp. It gives officers a white light to illuminate the interior and a red light for use with night vision equipment.

### **Police Equipment Mounting Bracket**

The Chrysler Group is also the only OEM to provide a standard Police Equipment Mounting Bracket. This unique bracket is installed in the center console area between the front and rear seats and provides a single surface to easily mount a radio, computer system, video control and other police equipment.

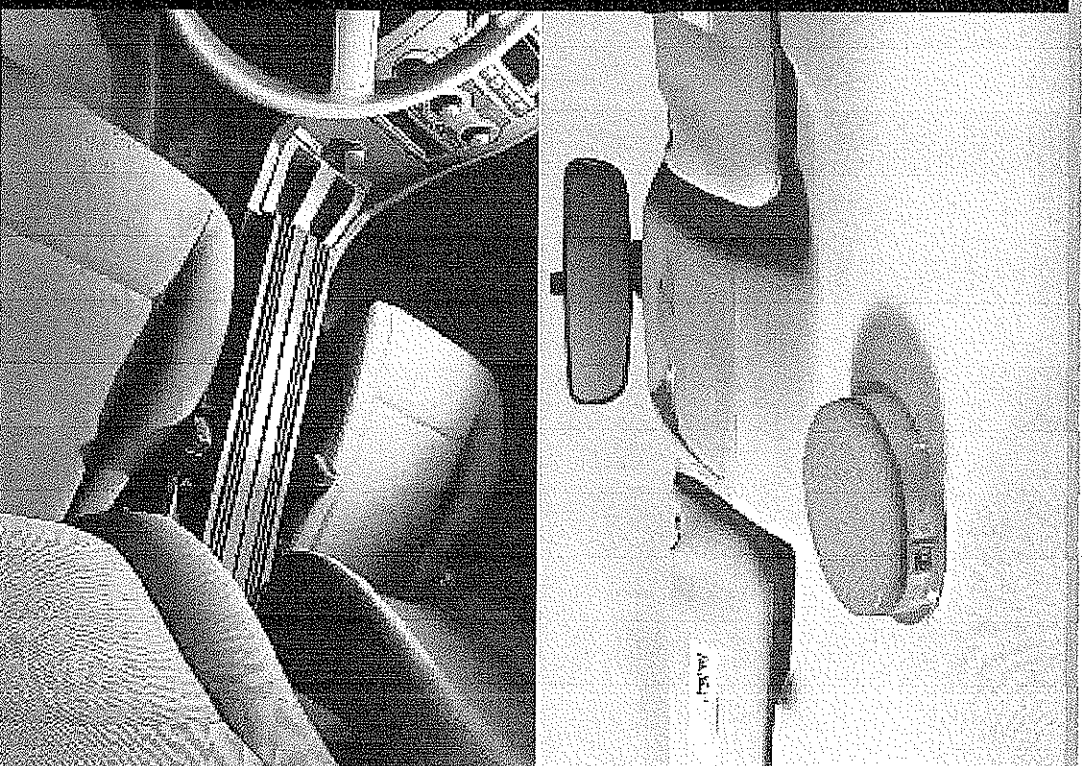



### **Police Equipment Interface Module**

Another feature unique to Charger and Magnum is the Police Equipment Interface Module. This police vehicle first gives upfitters a single interface connection for most aftermarket electrical police equipment. It's located under the instrument panel center stack area.

### **120-Amp Power Connection**

In the same location is a standard, auxiliary 120-amp power connection that consists of three 20-amp fused battery feeds and three 20-amp fused ignition feeds.

### **Easy Path Wiring Grommet**

Both Charger and Magnum are equipped with a unique Easy Path Wiring Grommet in the engine bulkhead. It makes wiring easier for upfitters and the flexible cone can be adjusted to the amount of wiring passing through, thus providing a tight seal to prevent moisture from entering the cabin.

### **Wigwags**

Completing our list of best-in-class interior features are the standard integrated headlamp and taillamp flashers, or wigwags. This police vehicle first — direct from an automotive manufacturer — provides a single connection that helps reduce the amount of time an upfitter would spend installing the wigwags. The wigwags must be activated by the upfitter.

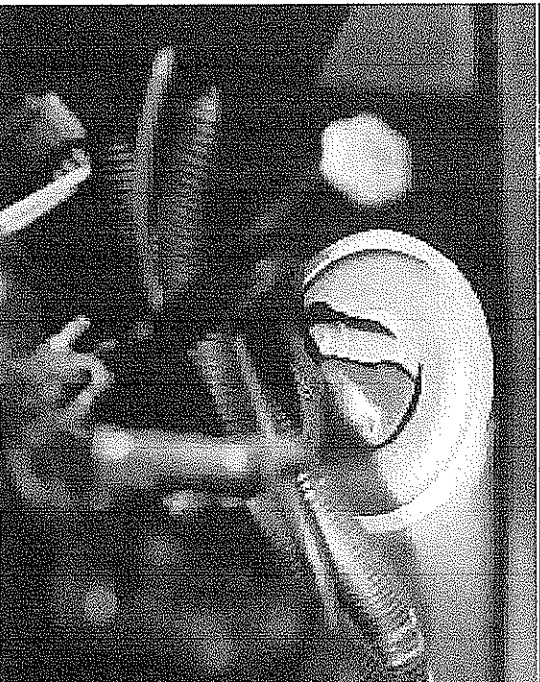
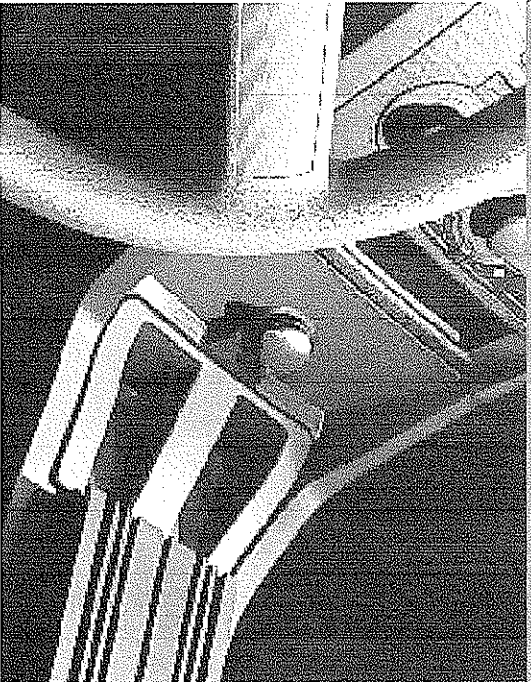



Dodge Charger and Magnum:  
Standard and Optional Police Equipment

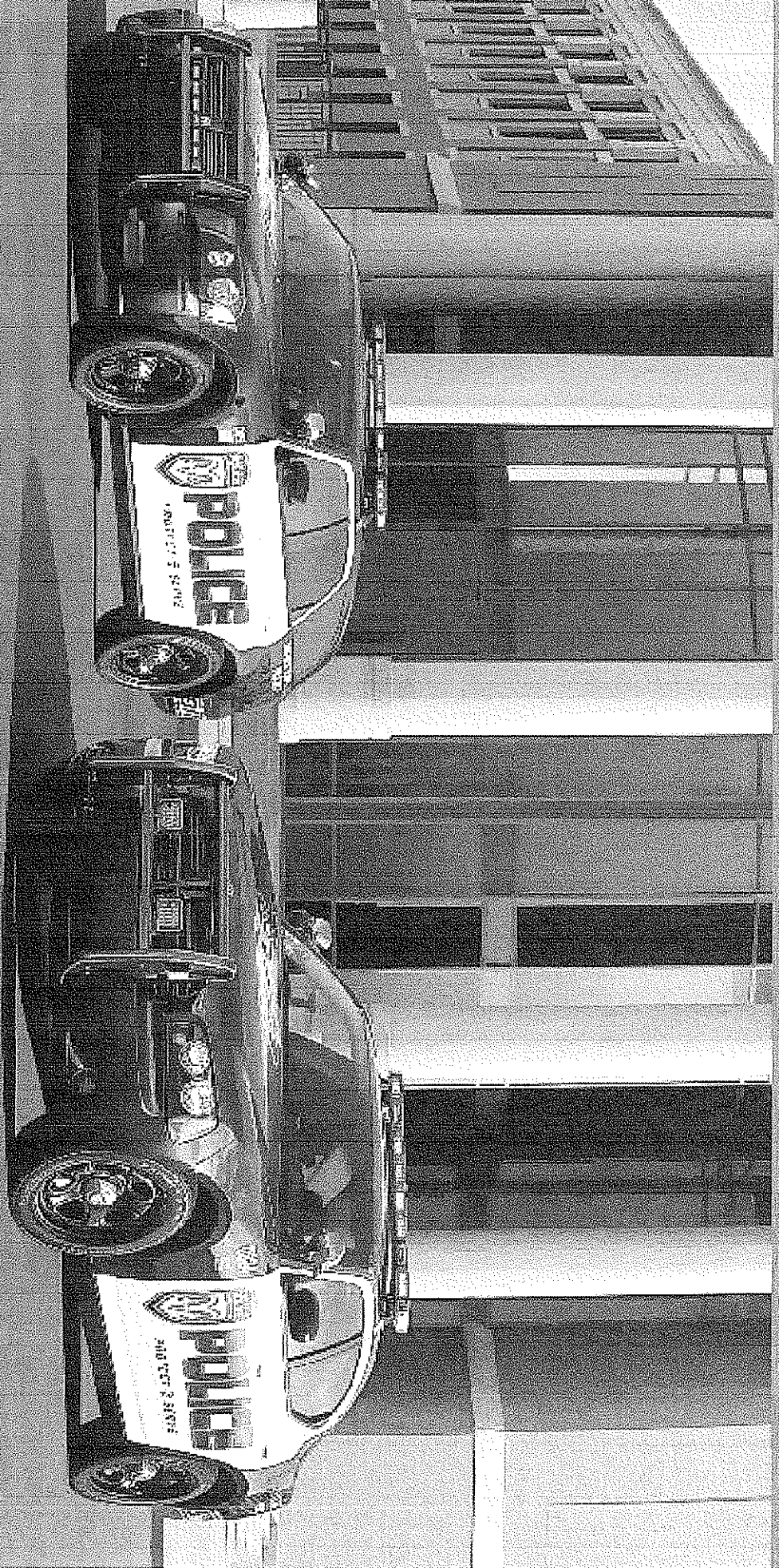

#### STANDARD POLICE EQUIPMENT

- 160-amp high-output alternator
- 160-mph or 260-km/h (certified) calibrated speedometer
- 18x7.5-inch steel wheels
- 3.5-liter High Output V6 engine with 250 hp @ 6,400 rpm and 250 lb-ft of torque @ 3,800 rpm
- 800 CCA battery
- AM/FM radio with CD player, changer controls, four speakers, and clock with auxiliary audio input jack
- Bright hubcaps
- Easy Path Wiring Grommet between underhood and passenger compartments
- External oil coolers: engine oil, transmission fluid, power steering fluid
- Five-speed automatic transmission with overdrive and AutoStick®
- Four-wheel disc heavy-duty antilock brakes with all-speed traction control
- Four-wheel independent performance suspension
- Heavy-duty cloth front bucket seats with manual lumbar and rear fixed cloth bench seat
- Fixed vinyl rear bench seat (Magnum)
- Instrument panel-mounted shift lever
- Load-leveling, height-control shock absorbers
- P225/60R18 BSW V-rated performance tires
- Police Equipment Mounting Bracket
- Police performance Electronic Stability Program (ESP)<sup>(1)</sup> with Brake Assist and all-speed traction control
- Police performance-tuned steering
- Trunk-lid/rear liftgate key lock cylinder (Charger/Magnum)

#### STANDARD POLICE EQUIPMENT (CONT)

- Security alarm system<sup>(2)</sup>
- Separate key and key fob
- Severe-duty cooling system

#### STANDARD POLICE ELECTRICAL EQUIPMENT

- Center instrument panel stack power connector with three 20-amp-fused battery feeds and three 20-amp-fused ignition feeds
- Dome lamp door switch deactivated
- Dual Spot Lamp Prep Package
- Integrated engine hour meter
- Police equipment interface module
- Separate fuses for left and right battery-fed spot lamps
- Software-controlled alternating head- and tailamps (wigwag)
- Stealth mode switch (turns off instrument cluster and radio indicators; PRNDL dials to lowest legal limit)
- Three pairs of twisted 18-gauge wiring for sirens, speakers or controls provided from interior to front bumper
- Underhood lamp

#### OPTIONAL POLICE EQUIPMENT

- 18-inch bolt-on wheel covers
- 5.7-liter HEMI® V8 with Multi-Displacement System and 340 hp @ 5,000 rpm and 390 lb-ft of torque @ 4,000 rpm
- Daytime running lamps
- Easy-clean black vinyl floor covering
- Emergency rear door lock override
- Engine block heater

#### OPTIONAL POLICE EQUIPMENT (CONT)

- Entire fleet keyed alike (without alarm)
- Fixed vinyl rear bench seat (Charger)
- Front-door bodyside molding delete
- Full-size spare tire and wheel with battery cover or cargo compartment floor mat
- Independently switched red/white LED dome lamp
- Power eight-way driver's seat
- Rear inside door locks and handles deactivated
- Rear windows inoperative from rear seat
- Supplemental side-curtain air bags<sup>(3)</sup> front and rear passenger<sup>(4)</sup>
- Spot lamp, driver's side or dual (Black or Chrome)

#### CHARGER AND MAGNUM POLICE MODELS INCLUDE:

- Air Bags<sup>(5)</sup> — Advanced multistage driver and front-passenger air bags
- Air Conditioning — Manual
- Brake-Park Interlock — Driver must apply brake before shifting from Park
- Defroster — Electric, rear window
- Gauges — 160-mph speedometer, tachometer, odometer, trip odometer, fuel level and coolant temperature, outside temperature
- Indicators (up to 18 depending on equipment) — Warning lamps for low oil pressure, charging system, low fuel and low washer fluid, seat belt reminder, door/trunk ajar, cruise, brake system, headlamp high beam, turn signals, engine and air bag

#### CHARGER AND MAGNUM POLICE MODELS INCLUDE: (CONT)

- Instrument Cluster
- Keyless Entry/Illuminated Entry

#### Lighting

- Exterior — Quad halogen headlamps with automatic off feature, tailamps and center high-mounted stoplamp
- Interior — Dual front map lamps, trunk lamp

#### Mirrors

- Exterior — Dual, power
- Interior — Day/night center rearview

#### Seat Belts

- Front — Height-adjustable, outboard shoulder belts, three-point
- Rear — Non-height-adjustable shoulder belts, three-point

#### Speed Control

- Steering Column — Tilt
- Windows — Power with driver's one-touch-down feature
- Windshield Wipers — Two-speed with variable intermittent modes

<sup>(1)</sup> No system, no matter how sophisticated, can repeal the laws of physics or overcome careless driving actions. Performance is limited by available traction, which snow, ice and other conditions can affect. When the ESP warning light in the speedometer flashes, the driver needs to use less throttle and adapt speed and driving behavior to prevailing road conditions. Always drive carefully, consistent with conditions. Please always wear your seat belt.

<sup>(2)</sup> Not available with key alike.

<sup>(3)</sup> Always use seat belts. Remember, a backseat is the safest place for children 12 and under.

<sup>(4)</sup> May not be compatible with some aftermarket equipment.

# Dodge Charger and Magnum:

## Dimensions/Specifications/Colors

### DIMENSIONS<sup>(1)</sup>/SPECIFICATIONS

| Exterior                      | Charger   | Magnum    |
|-------------------------------|-----------|-----------|
| Wheelbase                     | 120.0     | 120.0     |
| Overall Length                | 200.1     | 197.7     |
| Overall Height                | 58.2      | 58.3      |
| Overall Width                 | 74.5      | 74.1      |
| Front Track                   | 63.0      | 63.0      |
| Rear Track                    | 63.1      | 63.1      |
| Turning Diameter (ft)         | 38.9      | 38.9      |
| <b>Interior</b>               |           |           |
| Head Room (Front/Rear)        | 38.7/36.2 | 38.7/38.1 |
| Leg Room (Front/Rear)         | 41.8/40.2 | 41.8/40.2 |
| Shoulder Room (Front/Rear)    | 59.3/57.6 | 58.7/57.6 |
| Hip Room (Front/Rear)         | 56.2/55.5 | 56.2/55.5 |
| SAE Volume (cu ft)            | 104.0     | 105.9     |
| EPA Volume Index (cu ft)      | 120.2     | 133.1     |
| Seating Capacity              | 5         | 5         |
| Trunk Capacity (cu ft)        | 16.2      |           |
| Cargo Capacity (cu ft)        |           |           |
| – Rear Seat Up                |           | 27.2      |
| – Rear Seat Folded            |           | 71.6      |
| Curb Weight (lb estimated)    | 3,946     | 4,027     |
| Fuel Tank Capacity (U.S. gal) | 19        | 19        |

<sup>(1)</sup> Inches unless otherwise specified.

### EXTERIOR COLORS

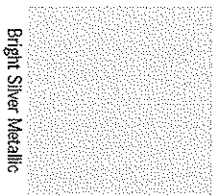

Bright Silver Metallic

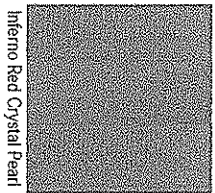

Inferno Red Crystal Pearl

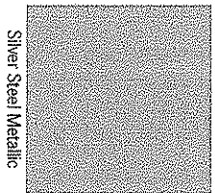

Silver Steel Metallic

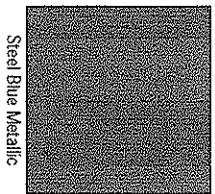

Steel Blue Metallic

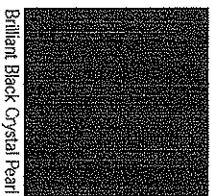

Brilliant Black Crystal Pearl

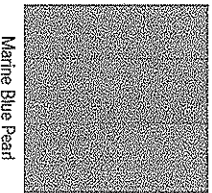

Marine Blue Pearl



Stone White

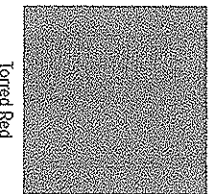

Torred Red

### SPECIAL PRODUCTION PAINT COLORS

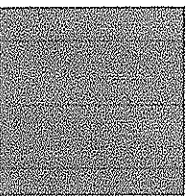

MS Blue, PY8999

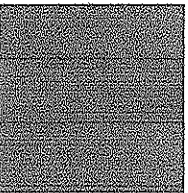

Forest Green, PY9324

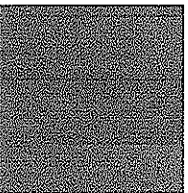

Navy Blue, PY9326

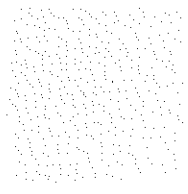

Cream, PY6672



## GEM Security Vehicle

The zero-emission GEM Security Vehicle gives your security fleet an alternative to gasoline-powered vehicles. This fully electric car exceeds federal regulations for low-speed vehicles.

With a range of up to 30 miles on a charge<sup>(1)</sup> and a top speed of 25 miles per hour, the GEM is perfect for patrolling shopping centers, downtown areas, large events, communities, campuses and many other purposes.

The GEM Security Vehicle offers three available roof-mounted light bars – LED, Amber and Blue. GEM also offers a P.A. System that includes sirens. Plus, the GEM electrical system allows for the easy addition of other security conveniences.<sup>(2)</sup>

For additional information, please contact your authorized GEM dealer, whose name and location are easily found at [gemcar.com](http://gemcar.com).

(1) Range may vary depending on temperature, terrain and driving style.  
(2) Aftermarket products must be 12 volts.





# Sales, Service and Technical Support

## REGIONAL GOVERNMENT AND ALTERNATIVE-FUEL SALES MANAGERS

### Roxie P. Thomas

Senior Manager  
GSA/Government Sales  
Office: (202) 414-6720  
rap17@dcx.com

### Gena Edwards

Great Lakes (Detroit) Business Center  
Office: (248) 838-4332  
Cell: (248) 761-4836  
gae2@dcx.com

### James McCoy

Southeast (Orlando) Business Center  
Office: (407) 826-7229  
Cell: (407) 421-4934  
jem17@dcx.com

### Joe Branda

Northeast (New York) Business Center  
Office: (845) 578-2180  
Cell: (845) 216-0621  
jgb@dcx.com

### Peter Kash

Southwest (Dallas) Business Center  
Office: (469) 374-4049  
Cell: (972) 679-5277  
pak12@dcx.com

### Roger Boyle

West (Los Angeles) Business Center  
Office: (949) 450-5169  
Cell: (949) 439-2144  
rmb2@dcx.com

### Susan Crockett

Mid-Atlantic (Washington, D.C.)  
Business Center  
Office: (410) 567-1847  
Cell: (410) 736-9730  
shc1@dcx.com

### Michelle Downing

Denver Business Center  
Office: (303) 793-8329  
Cell: (720) 244-8679  
mid6@dcx.com

### Tricia Llewellyn

Midwest (Chicago) Business Center  
Office: (630) 724-2357  
Cell: (630) 853-5951  
trl2@dcx.com

## FLEET SERVICE TEAM

### Bill Wunder

Senior Manager  
National Fleet Service  
(248) 512-7910  
wrrw@dcx.com

### Larry Baber

Fleet Service Manager  
Government/Bid  
(248) 512-8454  
lwb5@dcx.com

### Ron Szczepankowski

Regional Manager  
Rental/Warranty Administration  
(248) 512-7920  
rls15@dcx.com

## FLEET SERVICE REGIONAL MANAGERS

### Eric Gierst

Phoenix  
Seattle  
Los Angeles  
Las Vegas

(661) 270-1621

evg3@dcx.com

### Ben Hammond

Detroit  
Washington  
Pittsburgh  
(248) 512-7940

ebh2@dcx.com

### John 'Anson

Memphis  
Orlando  
Atlanta  
Charlotte  
Cincinnati  
(407) 826-7019

jin@dcx.com

### Chris Dunham

New York  
Connecticut  
Syracuse  
(845) 642-8105

crd32@dcx.com

### Bob McGeachy

Denver  
San Diego  
San Francisco  
Portland  
Hawaii

(805) 276-1692

rsm20@dcx.com

### Mike Esenbock

Milwaukee  
Minneapolis  
Chicago  
Kansas City  
(248) 512-7930

time1@dcx.com

### Jerry Pierson

New Orleans  
St. Louis  
Dallas  
Houston  
(314) 779-9302

jgp1@dcx.com

## POLICE TECHNICAL/UPFITTER SUPPORT MANAGERS

### Walt Melen

National Technical Support  
(248) 512-7444  
wmm25@dcx.com

### Gerry Appie

National Upfitter Support  
(248) 576-4117  
gla7@dcx.com

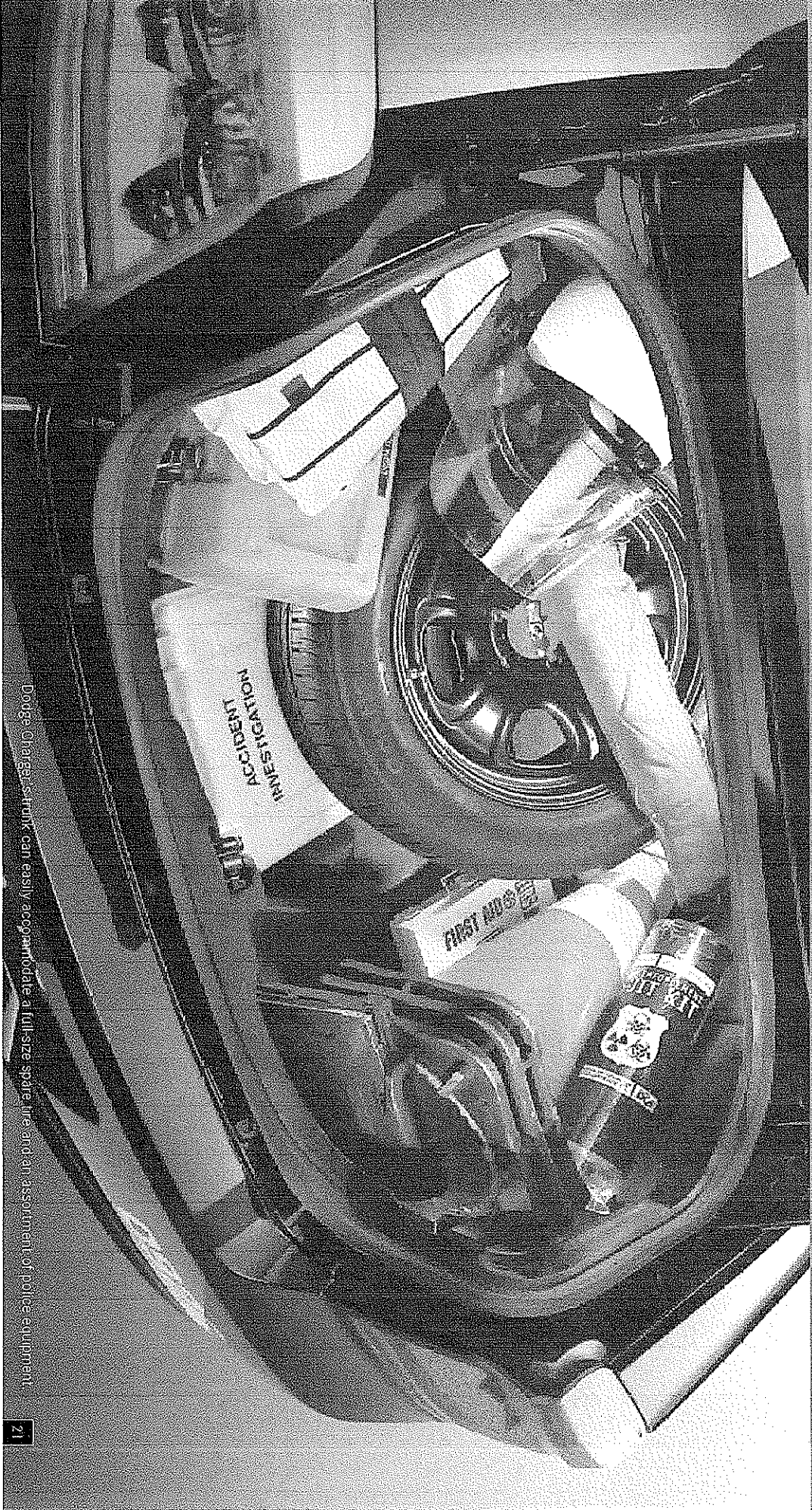

Dodge Charger's trunk can easily accommodate a full-size spare tire and an assortment of police equipment.





# All Points Bulletin for Dodge Police Vehicles

Please proceed to [www.fleet.chrysler.com/police](http://www.fleet.chrysler.com/police) to conduct surveillance on the following topics:

- Full-Line Police Vehicle Brochure
- Dodge Charger Police Vehicle Walkaround Video
- Texas Speedway Police Vehicle Ride & Drive Video
- Dodge Charger Police Vehicle Flyer
- Dodge Magnum Police Vehicle Flyer
- Police Vehicle Specifications
- Police Lifter's Guide
- Police Service Contract Information
- Photographs of Police Vehicles
- Press Releases of Police Vehicles
- Locate a Sales/Service Representative

Our Police Vehicle Web site is updated continuously to provide the most accurate information. Please visit it often.

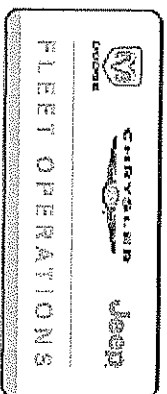

THE BRANDS THAT DRIVE BUSINESS™

