

State of West Virginia  
 Department of Administration  
 Purchasing Division  
 2019 Washington Street East  
 Post Office Box 50130  
 Charleston, WV 25305-0130

**Request for Quotation**

RFQ NUMBER  
**MOC17199**

PAGE  
**1**

ADDRESS CORRESPONDENCE TO ATTENTION OF  
**JOHN ABBOTT  
 304-558-2544**

**RFQ COPY**

TYPE NAME/ADDRESS HERE

\*404113354  
 GROVE MEDICAL, INC.  
 1089 PARK WEST BLVD  
 GREENVILLE, SC 29611  
 (864) 272-1549

DIVISION OF CORRECTIONS  
 MOUNT OLIVE CORRECTIONAL  
 CENTER  
 ONE MOUNTAINSIDE WAY  
 MT. OLIVE, WV  
 25185 304-442-7216

| DATE PRINTED | TERMS OF SALE | SHIP VIA | F.O.B. | FREIGHT TERMS |
|--------------|---------------|----------|--------|---------------|
| 05/09/2007   |               |          |        |               |

BID OPENING DATE: **05/24/2007** BID OPENING TIME **01:30PM**

| LINE   | QUANTITY | UOP | CAT NO | ITEM NUMBER | UNIT PRICE  | AMOUNT      |
|--|----------|-----|--------|-------------|-------------|-------------|
| 0001   | 1        | LS  | 035-95 |             | \$39,000.00 | \$39,000.00 |
| <p>THE PURCHASING DIVISION IS SOLICITING BIDS FOR THE MT. OLIVE CORRECTIONAL CENTER TO PROVIDE A COMPACT MOBILE X-RAY MACHINE.</p> <p>DELIVERY: DELIVERY SHALL BE INCLUDED IN THE BID; DELIVERY SHALL BE MADE BY 7/1/2007.</p> <p>ATTACHMENTS: 1. SPECIFICATIONS<br/>2. AFFIDAVIT</p> <p>VENDOR PREFERENCE CERTIFICATE</p> <p>CERTIFICATION AND APPLICATION* IS HEREBY MADE FOR PREFERENCE IN ACCORDANCE WITH WEST VIRGINIA CODE, 5A-3-37 (DOES NOT APPLY TO CONSTRUCTION CONTRACTS).</p> <p>A. APPLICATION IS MADE FOR 2.5% PREFERENCE FOR THE REASON CHECKED:</p> <p>( ) BIDDER IS AN INDIVIDUAL RESIDENT VENDOR AND HAS RESIDED CONTINUOUSLY IN WEST VIRGINIA FOR FOUR (4) YEARS IMMEDIATELY PRECEDING THE DATE OF THIS CERTIFICATION; OR</p> <p>( ) BIDDER IS A PARTNERSHIP, ASSOCIATION OR CORPORATION RESIDENT VENDOR AND HAS MAINTAINED ITS HEAD-QUARTERS OR PRINCIPAL PLACE OF BUSINESS CONTINUOUSLY IN WEST VIRGINIA FOR FOUR (4) YEARS IMMEDIATELY PRECEDING</p> |          |     |        |             |             |             |



SEE REVERSE SIDE FOR TERMS AND CONDITIONS

SIGNATURE: *Robert E. Haupt* TELEPHONE: *(864) 272-1549* DATE: *5/14/07*

TITLE: *Medicare Manager* FEIN: *57-0866600* ADDRESS CHANGES TO BE NOTED ABOVE

WHEN RESPONDING TO RFQ, INSERT NAME AND ADDRESS IN SPACE ABOVE LABELED 'VENDOR'



Quotation For: State of WV

Date: 17, May 2007

## QUOTATION

| Qty | System   | Unit Price<br>(USD) | Total<br>(USD) |
|-----|--|---------------------|----------------|
| 1   | <b>AUTOClear 6848 160KV with Multi Energy<br/>&amp; Organic Inorganic Stripping<br/>1 year warranty included</b> | \$29,300.00         | \$29,300.00    |
|     | <b><u>Options</u></b>  |                     |                |
|     | TIP Threat Image Projection  | \$ 5,500.00         | \$ 5,500.00    |
|     | Image Archiving  | \$ 3,100.00         | \$ 3,100.00    |
|     | Subtotal:  | \$ 37,900.00        | \$ 37,900.00   |
|     | Installation & Training:<br>Shipping:  | \$ 1100.00          | \$ 1100.00     |
|     | Grand Total:   | \$ 39,000.00        | \$39,000.00    |

# AUTOCLEAR 6848

## High Capacity Parcel X-ray for Explosives, Weapons & Narcotics

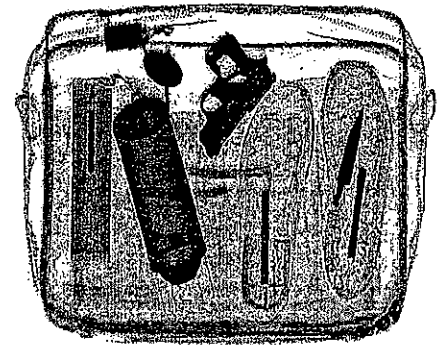
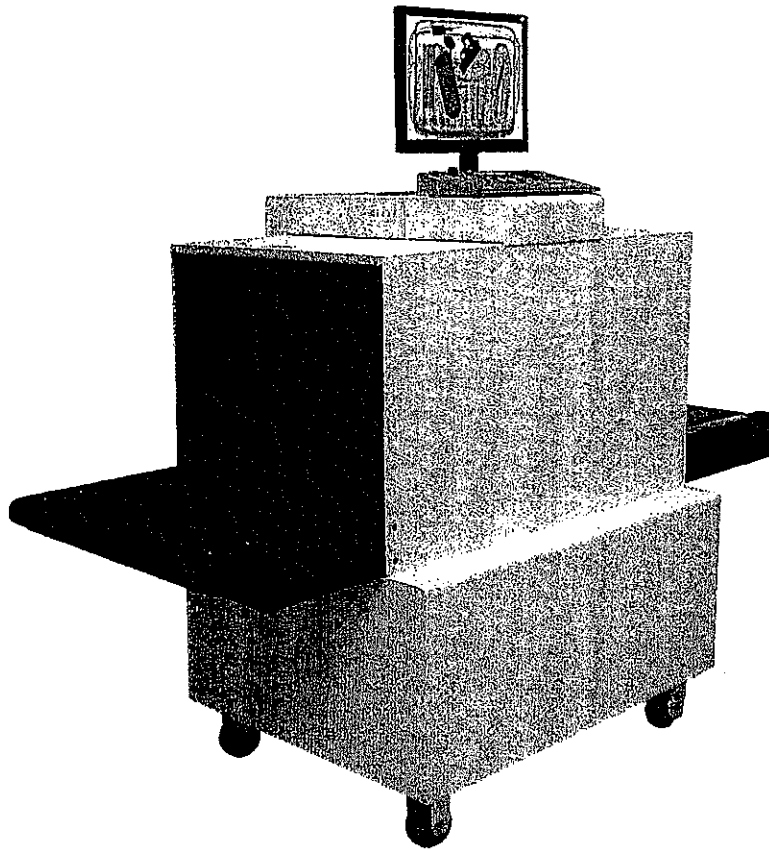

RealClear® reveals components of a gun, knife and bomb in real time, without lags and delays autoScale® displays contents at Pentium 4 resolution automatically and without distortion

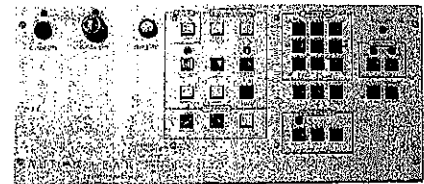

User-friendly, ergonomic and fully-featured operator control panel

Control Screening is the leading worldwide producer of fast, reliable and sophisticated X-ray, Metal and Trace Detection screening systems. Visit us at [www.controlscreening.com](http://www.controlscreening.com). Ask about our mobile and cargo systems. Our advanced systems and options are often integrated, leased or rented.

The AUTOCLEAR® 6848 (featuring a 68.0 cm wide x 48.0 cm high or 26.8" wide x 18.9" high tunnel opening) is a high capacity, high penetration, heavy-duty, conveyORIZED X-ray scanner designed to inspect carry-on bags, briefcases, mail trays and parcels. Ideal for use at:

**Airports • Seaports • Courts  
Customs • Corporate Facilities  
Government Buildings • Postal  
Checkpoints • Loading Docks  
Mailrooms • Corrections Facilities  
Nuclear • Access Control  
Special Events • Hospitals  
Rail or Bus Stations  
Police Stations • Military Bases**

### Features

- ➔ autoTracking® guided conveyor belt system never needs adjustment, lowering operating costs
- ➔ autoSensing® eliminates the need for troublesome photosensors or footpad switch. Assures 100% screening of thin blades or plastique in magazines or courier envelopes, or of bag already in tunnel at start-up
- ➔ Parcel contents are displayed at normal scale, wherever located, automatically and without distortion (autoScale®). RealClear® function reveals components of dense items in realtime without lags or delays
- ➔ Narrower footprint enhances security and conveniently fits in elevators, 36" doorways and tight spaces; conveyor end folds up for transport.
- ➔ Features Pentium 4, 17" monitor, RealClear®, autoScale®, autoDensAlert®, autoOutline®, autoSensing®, autoCal®, 64X Smart Zoom Lighten, Help, DensityScan, and Low Density Stripping, among other features
- ➔ Compact version (above) or airport version with extended conveyor(s)
- ➔ Multi-Energy Color option with Organic/Inorganic Stripping is popular. TIP, Training and Image Archiving also available. auto-Material®, option highlights suspect materials using atomic number and density
- ➔ Interactive training and highly responsive local service. Engineered, made and rigorously tested in the USA to ISO 9001 and regulatory standards

*Celebrating 70 years of excellence in design & support*

# AUTOCLEAR

[autoclearus.com](http://autoclearus.com)

Scintrex® • Federal Labs® • CheckGate® • CPAD • Control Screening  
U.S. Canada France Spain Dubai Latin America Singapore

# Model 6848 X-ray Specifications

|   |   |
|---|---|
| <b>Overall Dimensions:</b>  | 185.4 cm (73.0") L x 88.1 cm (34.7") W x 132.7 cm (52.3") H   |
| <b>Inspection Capabilities</b>  |   |
| Tunnel Size:  | 26.8" wide (68 cm)<br>18.9" high (48 cm)<br>L-shaped detector for 100% package screening  |
| Material Penetration:   | 28-29 mm steel  |
| Contrast Sensitivity:   | Over 2 million color tones standard   |
| Resolution:   | 40 AWG wire   |
| Processing:   | 32-bit adaptive image processing with minimum 128 Mbytes memory; 800 MHz or 2.4 GHz processor.  |
| Conveyor Speed:   | 48 feet per minute; 24 cm per second. Standard conveyor pictured on reverse. Extended conveyor length, Model 6040E (variable length entrance and exit bed) Fully reversible |
| Pulling Weight:   | 150 kg (331 lbs) (Higher pulling weights available)   |
| autoTracking®:  | Belt guaranteed to autoTrack for life   |
| Film Safety:  | Guaranteed for high-speed films up to ISO 1600 (33 DIN)   |
| <b>*Full autoSensing® without photosensors, moving parts, or footpad.</b> | <b>Reduces downtime and assures all magazines, envelopes or items are scanned, no matter how thin, or of bag already in tunnel at start-up. Enhances radiation safety.</b>  |

## X-ray Generator

|                      |                                   |
|----------------------|-----------------------------------|
| X-ray tube head:     | Self-contained, shielded tank     |
| High voltage rating: | 160 kV, 140 kV Operating Voltage  |
| Duty cycle:          | 100% with sealed oil bath cooling |
| Beam orientation:    | Diagonal (80° beam divergence)    |
| Dose rate per exam:  | 0.1 mR Lower doses available      |

## X-ray Detectors

Surface mounted, multilayer, fully integrated, high frequency, solid state detectors using high speed processors, and Pentium 4 image processing with Single Energy or optional Multi-Energy (M) Color

## Video

Standard with color 17" SVGA monitor High resolution, flicker-free, 21 dot pitch, low rad monitor, 1280 x 1024 video card Single energy color is based on object density. Multi-Energy color option available with available second monitor or flat screen or larger monitor(s), displays organics in orange and inorganics in blue, both overlapping in green and very dense objects in black and includes Organic and Inorganic Stripping

## Standard Features

- RealClear®
- autoDensAlert®
- autoTracking®
- autoSensing®
- autoOutline®
- autoScale®
- High density
- Help
- Fast (25 second) initial warm-up
- Fully functional, robust, low profile
- Reversible conveyor direction

## Options

- Multi-Energy organic and inorganic color & stripping
- autoMataAlert®
- Threat Image Projection (TiP)
- Rollerbed(s) or conveyor extensions
- Tropical Humidity Kit
- Image Archiving
- CE marking or UK approved
- Power conditioner, or UPS
- Table or locking monitor hood
- Locking metal keypad cover
- kV, mA meter or item counter
- LCD, dual or larger monitor(s)
- Footpad or optical on/off
- Variable height keypad mount
- Clear Lexan conveyor cover
- Remote operation, printer or VCR cable
- Built-in Training
- Rentals or leases
- autoNet
- TipNet

## Physical Details

|                                |   |
|--------------------------------|---|
| Dimensions:                    | See drawing   |
| Weight:                        | 890 lbs (403 kg)<br>1150 lbs (517 kg) crated  |
| Construction:                  | Unibody heavy gauge, epoxy painted steel construction with stainless steel and aluminum trim and accessories Non-marring casters and leveling jackscrews. Corrosion-resistant command center keypad mounted on side or on available table |
| Environmental Conditions:      | Temperature range: 32° - 104 °F, (0° - 40 °C)<br>Humidity 20% - 95%, non-condensing. Storage to 85 °C (149 °F)  |
| Electrical Power Requirements: | Consumption: < .6 kVA, 100, 120 volts AC ± 10% (-6 amps)<br>200, 220, 230, 240, 250 volts AC ± 10% (<3 amps)<br>All at 50 or 60 Hz  |

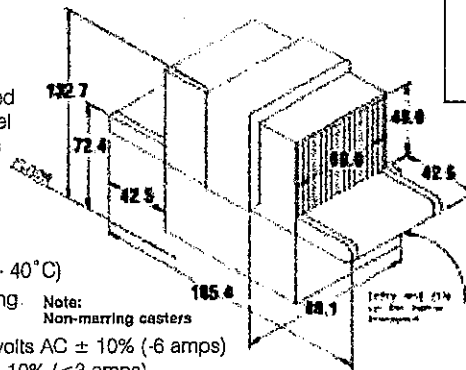

Dimensions are in centimeters

[www.autoclearus.com](http://www.autoclearus.com)

### World Headquarters Plant

2 Gardner Road  
Fairfield, NJ 07004-2206 USA  
Tel: + 1 (973) 276-6161  
Fax: + 1 (973) 276-6162  
leads@autoclearus.com

### Western U.S.

nw@autoclearus.com  
sw@autoclearus.com

### Continental Europe

France  
Tel: + 33 2 38 61 97 00  
Fax: + 33 2 38 61 97 01  
eu@autoclearus.com

### Spain, Italy, Mediterranean

Tel/Fax: +34 91 650 89 86  
lghedina@autoclearus.com

### Canada

#### Scintrex Trace Plant

300 Parkdale Ave, Ottawa  
Ontario, Canada K1Y 1G2  
Tel: + 1 (613) 224-1061  
Fax: + 1 (613) 224-2603  
info@autoclearus.com

### Asia

Singapore  
asia@autoclearus.com

### Latina/América Central

Dominican Republic  
latina@autoclearus.com

### Middle East

Dubai, UAE  
Tel: + 971 6 557 4505  
Fax: + 971 6 557 4507  
me@autoclearus.com

### Distributor:

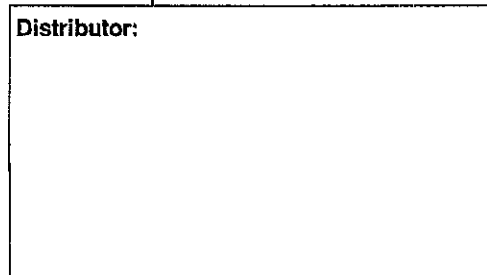

ISO 9001-2000 registered

[www.autoclearus.com](http://www.autoclearus.com)  
[www.tracedetection.com](http://www.tracedetection.com) [www.fed-labs.com](http://www.fed-labs.com)

Celebrating 70 years of excellence in design & support



autoclearus.com

Scintrex® • Federal Labs® • CheckGale® • CPAD • Control Screening  
U.S. Canada France Spain Dubai Latin America Singapore

**GENERAL TERMS & CONDITIONS  
REQUEST FOR QUOTATION (RFQ) AND REQUEST FOR PROPOSAL (RFP)**

1. Awards will be made in the best interest of the State of West Virginia.
2. The State may accept or reject in part, or in whole, any bid
3. All quotations are governed by the *West Virginia Code* and the *Legislative Rules* of the Purchasing Division.
4. Prior to any award, the apparent successful vendor must be properly registered with the Purchasing Division and have paid the required \$125.00 registration fee.
5. All services performed or goods delivered under State Purchase Orders/Contracts are to be continued for the term of the Purchase Order/Contract, contingent upon funds being appropriated by the Legislature or otherwise being made available. In the event funds are not appropriated or otherwise available for these services or goods, this Purchase Order/Contract becomes void and of no effect after June 30.
6. Payment may only be made after the delivery and acceptance of goods or services.
7. Interest may be paid for late payment in accordance with the *West Virginia Code*.
8. Vendor preference will be granted upon written request in accordance with the *West Virginia Code*.
9. The State of West Virginia is exempt from federal and state taxes and will not pay or reimburse such taxes.
10. The Director of Purchasing may cancel any Purchase Order/Contract upon 30 days written notice to the seller.
11. The laws of the State of West Virginia and the *Legislative Rules* of the Purchasing Division shall govern all rights and duties under the Contract, including without limitation the validity of this Purchase Order/Contract.
12. Any reference to automatic renewal is hereby deleted. The Contract may be renewed only upon mutual written agreement of the parties.
13. **BANKRUPTCY:** In the event the vendor/contractor files for bankruptcy protection, this contract is automatically null and void, and is terminated without further order.
14. **HIPAA Business Associate Addendum** - The West Virginia State Government HIPAA Business Associate Addendum (BAA), approved by the Attorney General, and available online at the Purchasing Division's web site (<http://www.state.wv.us/admin/purchase/vrc/hipaa.htm>) is hereby made part of the agreement. Provided that, the Agency meets the definition of a Covered Entity (45 CFR §160.103) and will be disclosing Protected Health Information (45 CFR §160.103) to the vendor.

---

**INSTRUCTIONS TO BIDDERS**

1. Use the quotation forms provided by the Purchasing Division.
2. **SPECIFICATIONS:** Items offered must be in compliance with the specifications. Any deviation from the specifications must be clearly indicated by the bidder. Alternates offered by the bidder as **EQUAL** to the specifications must be clearly defined. A bidder offering an alternate should attach complete specifications and literature to the bid. The Purchasing Division may waive minor deviations to specifications.
3. Complete all sections of the quotation form.
4. Unit prices shall prevail in cases of discrepancy.
5. All quotations are considered F.O.B. destination unless alternate shipping terms are clearly identified in the quotation.
6. **BID SUBMISSION:** All quotations must be delivered by the bidder to the office listed below prior to the date and time of the bid opening. Failure of the bidder to deliver the quotations on time will result in bid disqualifications.

**SIGNED BID TO:**

Department of Administration  
Purchasing Division  
2019 Washington Street East  
Post Office Box 50130  
Charleston, WV 25305-0130



State of West Virginia  
 Department of Administration  
 Purchasing Division  
 2019 Washington Street East  
 Post Office Box 50130  
 Charleston, WV 25305-0130

**Request for Quotation**

RFQ NUMBER  
**MOC17199**

PAGE  
**2**

ADDRESS CORRESPONDENCE TO ATTENTION OF  
**JOHN ABBOTT**  
**304-558-2544**

RFQ COPY

TYPE NAME/ADDRESS HERE  
**\*404113354**  
**Grove Medical**

SHIP TO

DIVISION OF CORRECTIONS  
 MOUNT OLIVE CORRECTIONAL  
 CENTER  
 ONE MOUNTAINSIDE WAY  
 MT. OLIVE, WV  
 25185 304-442-7216

| DATE PRINTED                 | TERMS OF SALE | SHIP VIA                 | FOB | FREIGHT TERMS |
|------------------------------|---------------|--------------------------|-----|---------------|
| 05/09/2007                   |               |                          |     |               |
| BID OPENING DATE: 05/24/2007 |               | BID OPENING TIME 01:30PM |     |               |

| LINE   | QUANTITY | UOP | CAT. NO. | ITEM NUMBER | UNIT PRICE | AMOUNT |
|--|----------|-----|----------|-------------|------------|--------|
|  |          |     |          |             |            |        |
| <p>THE DATE OF THIS CERTIFICATION; OR 80% OF THE OWNERSHIP INTEREST OF BIDDER IS HELD BY ANOTHER INDIVIDUAL, PARTNERSHIP, ASSOCIATION OR CORPORATION RESIDENT VENDOR WHO HAS MAINTAINED ITS HEADQUARTERS OR PRINCIPAL PLACE OF BUSINESS CONTINUOUSLY IN WEST VIRGINIA FOR FOUR (4) YEARS IMMEDIATELY PRECEDING THE DATE OF THIS CERTIFICATION; OR</p> <p>( ) BIDDER IS A CORPORATION NONRESIDENT VENDOR WHICH HAS AN AFFILIATE OR SUBSIDIARY WHICH EMPLOYS A MINIMUM OF ONE HUNDRED STATE RESIDENTS AND WHICH HAS MAINTAINED ITS HEADQUARTERS OR PRINCIPAL PLACE OF BUSINESS WITHIN WEST VIRGINIA CONTINUOUSLY FOR THE FOUR (4) YEARS IMMEDIATELY PRECEDING THE DATE OF THIS CERTIFICATION.</p> <p>B. APPLICATION IS MADE FOR 2.5% PREFERENCE FOR THE REASON CHECKED:</p> <p>( ) BIDDER IS A RESIDENT VENDOR WHO CERTIFIES THAT, DURING THE LIFE OF THE CONTRACT, ON AVERAGE AT LEAST 75% OF THE EMPLOYEES WORKING ON THE PROJECT BEING BID ARE RESIDENTS OF WEST VIRGINIA WHO HAVE RESIDED IN THE STATE CONTINUOUSLY FOR THE TWO YEARS IMMEDIATELY PRECEDING SUBMISSION OF THIS BID;</p> <p>OR</p> <p>( ) BIDDER IS A NONRESIDENT VENDOR EMPLOYING A MINIMUM OF ONE HUNDRED STATE RESIDENTS, OR IS A NONRESIDENT VENDOR WITH AN AFFILIATE OR SUBSIDIARY WHICH MAINTAINS ITS HEADQUARTERS OR PRINCIPAL PLACE OF BUSINESS WITHIN WEST VIRGINIA EMPLOYING A MINIMUM OF ONE HUNDRED STATE RESIDENTS WHO CERTIFIES THAT, DURING THE LIFE OF THE CONTRACT, ON AVERAGE AT LEAST 75% OF THE EMPLOYEES OR BIDDERS' AFFILIATE'S OR SUBSIDIARY'S EMPLOYEES ARE RESIDENTS OF WEST VIRGINIA WHO HAVE RESIDED IN THE STATE CONTINUOUSLY FOR THE TWO</p> |          |     |          |             |            |        |

SEE REVERSE SIDE FOR TERMS AND CONDITIONS

SIGNATURE: *Robert R. Mayhew* TELEPHONE: (804) 872-1549 DATE: 5/14/07

TITLE: *Medicare Manager* FEIN: 57-0866600 ADDRESS CHANGES TO BE NOTED ABOVE

WHEN RESPONDING TO RFQ, INSERT NAME AND ADDRESS IN SPACE ABOVE LABELED 'VENDOR'



State of West Virginia  
 Department of Administration  
 Purchasing Division  
 2019 Washington Street East  
 Post Office Box 50130  
 Charleston, WV 25305-0130

**Request for Quotation**

|            |
|------------|
| RFQ NUMBER |
| MOC17199   |

|      |
|------|
| PAGE |
| 3    |

|  |
|--|
| ADDRESS CORRESPONDENCE TO ATTENTION OF |
| JOHN ABBOTT<br>304-558-2544            |

RFQ COPY  
 TYPE NAME/ADDRESS HERE

VENDOR

SHIP TO

DIVISION OF CORRECTIONS  
 MOUNT OLIVE CORRECTIONAL  
 CENTER  
 ONE MOUNTAINSIDE WAY  
 MT. OLIVE, WV  
 25185 304-442-7216

| DATE PRINTED                 | TERMS OF SALE | SHIP VIA                 | F.O.B. | FREIGHT TERMS |
|------------------------------|---------------|--------------------------|--------|---------------|
| 05/09/2007                   |               |                          |        |               |
| BID OPENING DATE: 05/24/2007 |               | BID OPENING TIME 01:30PM |        |               |

| LINE  | QUANTITY | UOP | CAT NO | ITEM NUMBER                                     | UNIT PRICE | AMOUNT |
|---|----------|-----|--------|---|------------|--------|
| <p>YEARS IMMEDIATELY PRECEDING SUBMISSION OF THIS BID.</p> <p>BIDDER UNDERSTANDS IF THE SECRETARY OF TAX &amp; REVENUE DETERMINES THAT A BIDDER RECEIVING PREFERENCE HAS FAILED TO CONTINUE TO MEET THE REQUIREMENTS FOR SUCH PREFERENCE, THE SECRETARY MAY ORDER THE DIRECTOR OF PURCHASING TO: (A) RESCIND THE CONTRACT OR PURCHASE ORDER ISSUED; OR (B) ASSESS A PENALTY AGAINST SUCH BIDDER IN AN AMOUNT NOT TO EXCEED 5% OF THE BID AMOUNT AND THAT SUCH PENALTY WILL BE PAID TO THE CONTRACTING AGENCY OR DEDUCTED FROM ANY UNPAID BALANCE ON THE CONTRACT OR PURCHASE ORDER.</p> <p>BY SUBMISSION OF THIS CERTIFICATE, BIDDER AGREES TO DISCLOSE ANY REASONABLY REQUESTED INFORMATION TO THE PURCHASING DIVISION AND AUTHORIZES THE DEPARTMENT OF TAX AND REVENUE TO DISCLOSE TO THE DIRECTOR OF PURCHASING APPROPRIATE INFORMATION VERIFYING THAT BIDDER HAS PAID THE REQUIRED BUSINESS TAXES, PROVIDED THAT SUCH INFORMATION DOES NOT CONTAIN THE AMOUNTS OF TAXES PAID NOR ANY OTHER INFORMATION DEEMED BY THE TAX COMMISSIONER TO BE CONFIDENTIAL.</p> <p>UNDER PENALTY OF LAW FOR FALSE SWEARING (WEST VIRGINIA CODE 61-5-3), BIDDER HEREBY CERTIFIES THAT THIS CERTIFICATE IS TRUE AND ACCURATE IN ALL RESPECTS; AND THAT IF A CONTRACT IS ISSUED TO BIDDER, AND IF ANYTHING CONTAINED WITHIN THIS CERTIFICATE CHANGES DURING THE TERM OF THE CONTRACT, BIDDER WILL NOTIFY THE PURCHASING DIVISION IN WRITING IMMEDIATELY.</p> |          |     |        |   |            |        |
| BIDDER:   |          |     |        | <i>Robert R. May, Jr. - Grove Medical, Inc.</i> |            |        |
| DATE:   |          |     |        | <i>5/16/07</i>                                  |            |        |

|   |                                 |                                   |
|---|---------------------------------|-----------------------------------|
| SEE REVERSE SIDE FOR TERMS AND CONDITIONS |                                 |                                   |
| SIGNATURE <i>Robert R. May, Jr.</i>       | TELEPHONE <i>(864) 272-1549</i> | DATE <i>5/16/07</i>               |
| TITLE <i>Medicare Manager</i>             | FEIN <i>57-0866600</i>          | ADDRESS CHANGES TO BE NOTED ABOVE |

WHEN RESPONDING TO RFQ, INSERT NAME AND ADDRESS IN SPACE ABOVE LABELED 'VENDOR'



State of West Virginia  
 Department of Administration  
 Purchasing Division  
 2019 Washington Street East  
 Post Office Box 50130  
 Charleston, WV 25305-0130

**Request for Quotation**

RFQ NUMBER  
**MOC17199**

PAGE  
**4**

ADDRESS CORRESPONDENCE TO ATTENTION OF  
**JOHN ABBOTT  
 304-558-2544**

RFQ COPY  
 TYPE NAME/ADDRESS HERE

DIVISION OF CORRECTIONS  
 MOUNT OLIVE CORRECTIONAL  
 CENTER  
 ONE MOUNTAINSIDE WAY  
 MT. OLIVE, WV  
 25185 304-442-7216

| DATE PRINTED | TERMS OF SALE | SHIP VIA | FOB | FREIGHT TERMS |
|--------------|---------------|----------|-----|---------------|
| 05/09/2007   |               |          |     |               |

BID OPENING DATE: **05/24/2007** BID OPENING TIME **01:30PM**

| LINE  | QUANTITY | UOP | CAT. NO. | ITEM NUMBER | UNIT PRICE | AMOUNT |
|---|----------|-----|----------|-------------|------------|--------|
| <p>SIGNED: <i>Robert R. May, Jr.</i></p> <p>TITLE: <i>Medicare Manager</i></p> <p>* CHECK ANY COMBINATION OF PREFERENCE CONSIDERATION(S) IN EITHER "A" OR "B", OR BOTH "A" AND "B" WHICH YOU ARE ENTITLED TO RECEIVE. YOU MAY REQUEST UP TO THE MAXIMUM 5% PREFERENCE FOR BOTH "A" AND "B". (REV. 12/00)</p> <p>NOTICE</p> <p>A SIGNED BID MUST BE SUBMITTED TO:</p> <p>DEPARTMENT OF ADMINISTRATION<br/>                 PURCHASING DIVISION<br/>                 BUILDING 15<br/>                 2019 WASHINGTON STREET, EAST<br/>                 CHARLESTON, WV 25305-0130</p> <p>THE BID SHOULD CONTAIN THIS INFORMATION ON THE FACE OF THE ENVELOPE OR THE BID MAY NOT BE CONSIDERED:</p> <p>SEALED BID</p> <p>BUYER: JOHN ABBOTT</p> <p>RFQ. NO.: MOC17199</p> <p>BID OPENING DATE: 5/24/2007</p> |          |     |          |             |            |        |

SEE REVERSE SIDE FOR TERMS AND CONDITIONS

|                                     |                          |                                   |
|-------------------------------------|--------------------------|-----------------------------------|
| SIGNATURE <i>Robert R. May, Jr.</i> | TELEPHONE (804) 272-1549 | DATE 5/16/07                      |
| TITLE <i>Medicare Manager</i>       | FEIN 57-0866000          | ADDRESS CHANGES TO BE NOTED ABOVE |

WHEN RESPONDING TO RFQ, INSERT NAME AND ADDRESS IN SPACE ABOVE LABELED 'VENDOR'





State of West Virginia  
 Department of Administration  
 Purchasing Division  
 2019 Washington Street East  
 Post Office Box 50130  
 Charleston, WV 25305-0130

**Request for Quotation**

|            |
|------------|
| RFQ NUMBER |
| MOC17199   |

|      |
|------|
| PAGE |
| 5    |

|  |
|--|
| ADDRESS CORRESPONDENCE TO ATTENTION OF |
| JOHN ABBOTT<br>304-558-2544            |

RFQ COPY  
 TYPE NAME/ADDRESS HERE

DIVISION OF CORRECTIONS  
 MOUNT OLIVE CORRECTIONAL  
 CENTER  
 ONE MOUNTAINSIDE WAY  
 MT. OLIVE, WV  
 25185 304-442-7216

| DATE PRINTED | TERMS OF SALE | SHIP VIA | FOB | FREIGHT TERMS |
|--------------|---------------|----------|-----|---------------|
| 05/09/2007   |               |          |     |               |

BID OPENING DATE: 05/24/2007 BID OPENING TIME 01:30PM

| LINE  | QUANTITY | UOP | CAT NO | ITEM NUMBER | UNIT PRICE | AMOUNT             |
|---|----------|-----|--------|-------------|------------|--------------------|
| BID OPENING TIME: 1:30 PM-----  |          |     |        |             |            |                    |
| PLEASE PROVIDE A FAX NUMBER IN CASE IT IS NECESSARY<br>TO CONTACT YOU REGARDING YOUR BID:<br>(864) 272-1549 |          |     |        |             |            |                    |
| CONTACT PERSON (PLEASE PRINT CLEARLY):<br>Rob Mays  |          |     |        |             |            |                    |
| ***** THIS IS THE END OF RFQ MOC17199 *****   |          |     |        |             |            | TOTAL: \$39,000.00 |

SEE REVERSE SIDE FOR TERMS AND CONDITIONS

|                                    |                           |                                   |
|------------------------------------|---------------------------|-----------------------------------|
| SIGNATURE<br><i>Robert R. Mays</i> | TELEPHONE<br>864-272-1549 | DATE<br>5/16/07                   |
| TITLE<br>Medicare Manager          | FEIN<br>57-0866600        | ADDRESS CHANGES TO BE NOTED ABOVE |

WHEN RESPONDING TO RFQ, INSERT NAME AND ADDRESS IN SPACE ABOVE LABELED 'VENDOR'

P6

**MOC17199 – COMPACT MOBILE X-RAY MACHINE SPECIFICATIONS**

The X-Ray machine (hereinafter referred to as "machine") shall be a high capacity parcel model Autoclear 6848M, or equal. Machine will be used in a maximum security prison. Should an equal be bid, any literature, colored brochures, and/or specification sheets shall be provided. The machine shall have the minimum specifications as stated:

- 68.0 CM Wide X 48.0 CM high; or 26.8" Wide X 18.9" high tunnel opening
- High capacity; High penetration; Heavy duty, conveyor-type x-ray scanner designed to inspect carry-on bags, briefcases, mail trays, and parcels.
- Must fit in elevators, 36" doorways and other tight spaces
- Conveyor end must fold up for transport to be used in other high critical areas in a timely situation
- Multi-energy color option with organic/in-organic stripping
- Tip, training, and image archiving must be supplied
- Option highlights suspect materials using atomic number & density
- Bid price must include shipping and a minimum one (1) year parts and labor warranty
- Delivery must be made by 7/1/2007 – so long as the purchase order has been received by the vendor from the State of West Virginia by 6/1/2007. The number of days after 6/1/2007 will be the number of days the vendor will have to deliver the machine
- Notes to remember: Please complete the attached "Purchasing Affidavit", sign the bid, and provide the requested information on the Request for Quotation. If the vendor is not registered with the Division of Purchasing, please contact Jeanne Barnhart at (304) 558-2311 to become registered; so should an award be made, the delivery will not become an issue. Vendors may also call Ms. Barnhart to determine if they are current with the Purchasing Division.

RFQ No. \_\_\_\_\_

STATE OF WEST VIRGINIA  
Purchasing Division

**PURCHASING AFFIDAVIT**

**West Virginia Code §5A-3-10a states:** No contract or renewal of any contract may be awarded by the state or any of its political subdivisions to any vendor or prospective vendor when the vendor or prospective vendor or a related party to the vendor or prospective vendor is a debtor and the debt owned is an amount greater than one thousand dollars in the aggregate

**DEFINITIONS:**

"Debt" means any assessment, premium, penalty, fine, tax or other amount of money owed to the state or any of its political subdivisions because of a judgment, fine, permit violation, license assessment, defaulted workers' compensation premium, penalty or other assessment presently delinquent or due and required to be paid to the state or any of its political subdivisions, including any interest or additional penalties accrued thereon.

"Debtor" means any individual, corporation, partnership, association, limited liability company or any other form or business association owing a debt to the state or any of its political subdivisions. "Political subdivision" means any county commission; municipality; county board of education; any instrumentality established by a county or municipality; any separate corporation or instrumentality established by one or more counties or municipalities, as permitted by law; or any public body charged by law with the performance of a government function or whose jurisdiction is coextensive with one or more counties or municipalities. "Related party" means a party, whether an individual, corporation, partnership, association, limited liability company or any other form or business association or other entity whatsoever, related to any vendor by blood, marriage, ownership or contract through which the party has a relationship of ownership or other interest with the vendor so that the party will actually or by effect receive or control a portion of the benefit, profit or other consideration from performance of a vendor contract with the party receiving an amount that meets or exceed five percent of the total contract amount.

**EXCEPTION:** The prohibition of this section does not apply where a vendor has contested any tax administered pursuant to chapter eleven of this code, workers' compensation premium, permit fee or environmental fee or assessment and the matter has not become final or where the vendor has entered into a payment plan or agreement and the vendor is not in default of any of the provisions of such plan or agreement.

**LICENSING:** Vendors must be licensed and in good standing in accordance with any and all state and local laws and requirements by any state or local agency of West Virginia, including, but not limited to, the West Virginia Secretary of State's Office, the West Virginia Tax Department, West Virginia Insurance Commission, or any other state agencies or political subdivision. Furthermore, the vendor must provide all necessary releases to obtain information to enable the Director or spending unit to verify that the vendor is licensed and in good standing with the above entities.

**CONFIDENTIALITY:** The vendor agrees that he or she will not disclose to anyone, directly or indirectly, any such personally identifiable information or other confidential information gained from the agency, unless the individual who is the subject of the information consents to the disclosure in writing or the disclosure is made pursuant to the agency's policies, procedures and rules. Vendors should visit [www.state.wv.us/admin/purchase/privacy](http://www.state.wv.us/admin/purchase/privacy) for the Notice of Agency Confidentiality Policies.

Under penalty of law for false swearing (West Virginia Code, §61-5-3), it is hereby certified that the vendor acknowledges the information in this said affidavit and are in compliance with the requirements as stated.

Vendor's Name: Grove Medical, Inc.

Authorized Signature: Robert R. Maynor Date: 5/16/07