



State of West Virginia
 Department of Administration
 Purchasing Division
 2019 Washington Street East
 Post Office Box 50130
 Charleston, WV 25305-0130

Request for Quotation

RFQ NUMBER
MOC17199

PAGE
1

ADDRESS CORRESPONDENCE TO ATTENTION OF:
JOHN ABBOTT 304-558-2544

VENDOR

*506115049 724-837-5411
 CONTROL SCREENING LLC
 35 WEST PITTSBURGH STREET
 3RD FLOOR
 GREENSBURG PA 15601-5142

SHIP TO

DIVISION OF CORRECTIONS
 MOUNT OLIVE CORRECTIONAL
 CENTER
 ONE MOUNTAINSIDE WAY
 MT. OLIVE, WV
 25185 304-442-7216

DATE PRINTED	TERMS OF SALE	SHIP VIA	F.O.B.	FREIGHT TERMS
05/09/2007				

BID OPENING DATE: 05/24/2007 BID OPENING TIME 01:30PM

LINE	QUANTITY	UOP	CAT NO.	ITEM NUMBER	UNIT PRICE	AMOUNT
0001	1	LS		035-95	\$ 27,758. ⁰⁰	\$ 27,758. ⁰⁰
<p>THE PURCHASING DIVISION IS SOLICITING BIDS FOR THE MT. OLIVE CORRECTIONAL CENTER TO PROVIDE A COMPACT MOBILE X-RAY MACHINE.</p> <p>DELIVERY: DELIVERY SHALL BE INCLUDED IN THE BID; DELIVERY SHALL BE MADE BY 7/1/2007.</p> <p>ATTACHMENTS: 1. SPECIFICATIONS 2. AFFIDAVIT</p> <p>VENDOR PREFERENCE CERTIFICATE</p> <p>CERTIFICATION AND APPLICATION* IS HEREBY MADE FOR PREFERENCE IN ACCORDANCE WITH WEST VIRGINIA CODE, 5A-3-37 (DOES NOT APPLY TO CONSTRUCTION CONTRACTS).</p> <p>A. APPLICATION IS MADE FOR 2.5% PREFERENCE FOR THE REASON CHECKED:</p> <p>() BIDDER IS AN INDIVIDUAL RESIDENT VENDOR AND HAS RESIDED CONTINUOUSLY IN WEST VIRGINIA FOR FOUR (4) YEARS IMMEDIATELY PRECEDING THE DATE OF THIS CERTIFICATION; OR</p> <p>() BIDDER IS A PARTNERSHIP, ASSOCIATION OR CORPORATION RESIDENT VENDOR AND HAS MAINTAINED ITS HEAD-QUARTERS OR PRINCIPAL PLACE OF BUSINESS CONTINUOUSLY IN WEST VIRGINIA FOR FOUR (4) YEARS IMMEDIATELY PRECEDING</p>						

RECEIVED
 MAY 22 10 12 02
 PURCHASING DIVISION
 STATE OF WV

SIGNATURE <i>Dennis Cunningham</i>				TELEPHONE 724-837-5411		DATE 5/21/07	
TITLE SALES DIRECTOR		FEIN 22-2964823		ADDRESS CHANGES TO BE NOTED ABOVE			

WHEN RESPONDING TO RFQ, INSERT NAME AND ADDRESS IN SPACE ABOVE LABELED 'VENDOR'



State of West Virginia
 Department of Administration
 Purchasing Division
 2019 Washington Street East
 Post Office Box 50130
 Charleston, WV 25305-0130

Request for Quotation

RFQ NUMBER
MOC17199

PAGE
2

ADDRESS CORRESPONDENCE TO ATTENTION OF:
JOHN ABBOTT 304-558-2544

VENDOR

*506115049 724-837-5411
 CONTROL SCREENING LLC
 35 WEST PITTSBURGH STREET
 3RD FLOOR
 GREENSBURG PA 15601-5142

SHIP TO

DIVISION OF CORRECTIONS
 MOUNT OLIVE CORRECTIONAL
 CENTER
 ONE MOUNTAINSIDE WAY
 MT. OLIVE, WV
 25185 304-442-7216

DATE PRINTED	TERMS OF SALE	SHIP VIA	F.O.B.	FREIGHT TERMS
05/09/2007				

BID OPENING DATE: **05/24/2007** BID OPENING TIME **01:30PM**

LINE	QUANTITY	UOP	CAT NO.	ITEM NUMBER	UNIT PRICE	AMOUNT
<p>THE DATE OF THIS CERTIFICATION; OR 80% OF THE OWNERSHIP INTEREST OF BIDDER IS HELD BY ANOTHER INDIVIDUAL, PARTNERSHIP, ASSOCIATION OR CORPORATION RESIDENT VENDOR WHO HAS MAINTAINED ITS HEADQUARTERS OR PRINCIPAL PLACE OF BUSINESS CONTINUOUSLY IN WEST VIRGINIA FOR FOUR (4) YEARS IMMEDIATELY PRECEDING THE DATE OF THIS CERTIFICATION; OR</p> <p>() BIDDER IS A CORPORATION NONRESIDENT VENDOR WHICH HAS AN AFFILIATE OR SUBSIDIARY WHICH EMPLOYS A MINIMUM OF ONE HUNDRED STATE RESIDENTS AND WHICH HAS MAINTAINED ITS HEADQUARTERS OR PRINCIPAL PLACE OF BUSINESS WITHIN WEST VIRGINIA CONTINUOUSLY FOR THE FOUR (4) YEARS IMMEDIATELY PRECEDING THE DATE OF THIS CERTIFICATION.</p> <p>B. APPLICATION IS MADE FOR 2.5% PREFERENCE FOR THE REASON CHECKED:</p> <p>() BIDDER IS A RESIDENT VENDOR WHO CERTIFIES THAT, DURING THE LIFE OF THE CONTRACT, ON AVERAGE AT LEAST 75% OF THE EMPLOYEES WORKING ON THE PROJECT BEING BID ARE RESIDENTS OF WEST VIRGINIA WHO HAVE RESIDED IN THE STATE CONTINUOUSLY FOR THE TWO YEARS IMMEDIATELY PRECEDING SUBMISSION OF THIS BID;</p> <p>OR</p> <p>() BIDDER IS A NONRESIDENT VENDOR EMPLOYING A MINIMUM OF ONE HUNDRED STATE RESIDENTS OR IS A NONRESIDENT VENDOR WITH AN AFFILIATE OR SUBSIDIARY WHICH MAINTAINS ITS HEADQUARTERS OR PRINCIPAL PLACE OF BUSINESS WITHIN WEST VIRGINIA EMPLOYING A MINIMUM OF ONE HUNDRED STATE RESIDENTS WHO CERTIFIES THAT, DURING THE LIFE OF THE CONTRACT, ON AVERAGE AT LEAST 75% OF THE EMPLOYEES OR BIDDERS' AFFILIATE'S OR SUBSIDIARY'S EMPLOYEES ARE RESIDENTS OF WEST VIRGINIA WHO HAVE RESIDED IN THE STATE CONTINUOUSLY FOR THE TWO</p>						

SEE REVERSE SIDE FOR TERMS AND CONDITIONS

SIGNATURE <i>Dennis Cunningham</i>	TELEPHONE 724-837-5411	DATE 5/21/07
TITLE SALES DIRECTOR	FERN 22-2964823	ADDRESS CHANGES TO BE NOTED ABOVE

WHEN RESPONDING TO RFQ, INSERT NAME AND ADDRESS IN SPACE ABOVE LABELED 'VENDOR'



State of West Virginia
 Department of Administration
 Purchasing Division
 2019 Washington Street East
 Post Office Box 50130
 Charleston, WV 25305-0130

Request for Quotation

RFQ NUMBER
MOC17199

PAGE
3

ADDRESS CORRESPONDENCE TO ATTENTION OF:
JOHN ABBOTT
304-558-2544

VENDOR
 *506115049 724-837-5411
CONTROL SCREENING LLC
35 WEST PITTSBURGH STREET
3RD FLOOR
GREENSBURG PA 15601-5142

SHIP TO
DIVISION OF CORRECTIONS
MOUNT OLIVE CORRECTIONAL
CENTER
ONE MOUNTAINSIDE WAY
MT. OLIVE, WV
25185 304-442-7216

DATE PRINTED 05/09/2007	TERMS OF SALE	SHIP VIA	F.O.B.	FREIGHT TERMS
BID OPENING DATE: 05/24/2007		BID OPENING TIME		01:30PM

LINE	QUANTITY	UOP	CAT NO.	ITEM NUMBER	UNIT PRICE	AMOUNT
<p>YEARS IMMEDIATELY PRECEDING SUBMISSION OF THIS BID.</p> <p>BIDDER UNDERSTANDS IF THE SECRETARY OF TAX & REVENUE DETERMINES THAT A BIDDER RECEIVING PREFERENCE HAS FAILED TO CONTINUE TO MEET THE REQUIREMENTS FOR SUCH PREFERENCE, THE SECRETARY MAY ORDER THE DIRECTOR OF PURCHASING TO: (A) RESCIND THE CONTRACT OR PURCHASE ORDER ISSUED; OR (B) ASSESS A PENALTY AGAINST SUCH BIDDER IN AN AMOUNT NOT TO EXCEED 5% OF THE BID AMOUNT AND THAT SUCH PENALTY WILL BE PAID TO THE CONTRACTING AGENCY OR DEDUCTED FROM ANY UNPAID BALANCE ON THE CONTRACT OR PURCHASE ORDER.</p> <p>BY SUBMISSION OF THIS CERTIFICATE, BIDDER AGREES TO DISCLOSE ANY REASONABLY REQUESTED INFORMATION TO THE PURCHASING DIVISION AND AUTHORIZES THE DEPARTMENT OF TAX AND REVENUE TO DISCLOSE TO THE DIRECTOR OF PURCHASING APPROPRIATE INFORMATION VERIFYING THAT BIDDER HAS PAID THE REQUIRED BUSINESS TAXES, PROVIDED THAT SUCH INFORMATION DOES NOT CONTAIN THE AMOUNTS OF TAXES PAID NOR ANY OTHER INFORMATION DEEMED BY THE TAX COMMISSIONER TO BE CONFIDENTIAL.</p> <p>UNDER PENALTY OF LAW FOR FALSE SWEARING (WEST VIRGINIA CODE 61-5-3), BIDDER HEREBY CERTIFIES THAT THIS CERTIFICATE IS TRUE AND ACCURATE IN ALL RESPECTS; AND THAT IF A CONTRACT IS ISSUED TO BIDDER AND IF ANYTHING CONTAINED WITHIN THIS CERTIFICATE CHANGES DURING THE TERM OF THE CONTRACT, BIDDER WILL NOTIFY THE PURCHASING DIVISION IN WRITING IMMEDIATELY.</p> <p>BIDDER: <u>CONTROL SCREENING LLC</u></p> <p>DATE: <u>5/21/07</u></p>						

SEE REVERSE SIDE FOR TERMS AND CONDITIONS			
SIGNATURE <i>[Signature]</i>	TELEPHONE 724-837-5411	DATE 5/21/07	
TITLE SALES DIRECTOR	FEIN 22-2964823	ADDRESS CHANGES TO BE NOTED ABOVE	

WHEN RESPONDING TO RFQ, INSERT NAME AND ADDRESS IN SPACE ABOVE LABELED 'VENDOR'



State of West Virginia
 Department of Administration
 Purchasing Division
 2019 Washington Street East
 Post Office Box 50130
 Charleston, WV 25305-0130

Request for Quotation

RFQ NUMBER
MOC17199

PAGE
4

ADDRESS CORRESPONDENCE TO ATTENTION OF:
JOHN ABBOTT
304-558-2544

VENDOR
 *506115049 724-837-5411
CONTROL SCREENING LLC
35 WEST PITTSBURGH STREET
3RD FLOOR
GREENSBURG PA 15601-5142

SHIP TO
DIVISION OF CORRECTIONS
MOUNT OLIVE CORRECTIONAL
CENTER
ONE MOUNTAINSIDE WAY
MT. OLIVE, WV
25185 304-442-7216

DATE PRINTED 05/09/2007	TERMS OF SALE	SHIP VIA	F.O.B.	FREIGHT TERMS
-----------------------------------	---------------	----------	--------	---------------

BID OPENING DATE: **05/24/2007** BID OPENING TIME **01:30PM**

LINE	QUANTITY	UOP	CAT NO	ITEM NUMBER	UNIT PRICE	AMOUNT
<p>SIGNED: <i>Dennis Cunningham</i> ----- DENNIS CUNNINGHAM</p> <p>TITLE: <i>SALES DIRECTOR</i> -----</p> <p>* CHECK ANY COMBINATION OF PREFERENCE CONSIDERATION(S) IN EITHER "A" OR "B", OR BOTH "A" AND "B" WHICH YOU ARE ENTITLED TO RECEIVE. YOU MAY REQUEST UP TO THE MAXIMUM 5% PREFERENCE FOR BOTH "A" AND "B". (REV. 12/00)</p> <p>NOTICE</p> <p>A SIGNED BID MUST BE SUBMITTED TO:</p> <p>DEPARTMENT OF ADMINISTRATION PURCHASING DIVISION BUILDING 15 2019 WASHINGTON STREET, EAST CHARLESTON, WV 25305-0130</p> <p>THE BID SHOULD CONTAIN THIS INFORMATION ON THE FACE OF THE ENVELOPE OR THE BID MAY NOT BE CONSIDERED:</p> <p>SEALED BID</p> <p>BUYER: JOHN ABBOTT-----</p> <p>RFQ. NO.: MOC17199-----</p> <p>BID OPENING DATE: 5/24/2007-----</p>						

SEE REVERSE SIDE FOR TERMS AND CONDITIONS

SIGNATURE <i>Dennis Cunningham</i>	TELEPHONE 724-837-5411	DATE 5/21/07
TITLE SALES DIRECTOR	FEIN 22-2964823	ADDRESS CHANGES TO BE NOTED ABOVE

WHEN RESPONDING TO RFQ, INSERT NAME AND ADDRESS IN SPACE ABOVE LABELED 'VENDOR'



State of West Virginia
 Department of Administration
 Purchasing Division
 2019 Washington Street East
 Post Office Box 50130
 Charleston, WV 25305-0130

Request for Quotation

RFQ NUMBER
MOC17199

PAGE
5

ADDRESS CORRESPONDENCE TO ATTENTION OF:
JOHN ABBOTT
304-558-2544

VENDOR
 *506115049 724-837-5411
CONTROL SCREENING LLC
35 WEST PITTSBURGH STREET
3RD FLOOR
GREENSBURG PA 15601-5142

SHIP TO
DIVISION OF CORRECTIONS
MOUNT OLIVE CORRECTIONAL
CENTER
ONE MOUNTAINSIDE WAY
MT. OLIVE, WV
25185 304-442-7216

DATE PRINTED 05/09/2007	TERMS OF SALE	SHIP VIA	F.O.B.	FREIGHT TERMS
-----------------------------------	---------------	----------	--------	---------------

BID OPENING DATE: **05/24/2007** BID OPENING TIME **01:30PM**

LINE	QUANTITY	UOP	CAT NO.	ITEM NUMBER	UNIT PRICE	AMOUNT
<p>BID OPENING TIME: 1:30 PM-----</p> <p>PLEASE PROVIDE A FAX NUMBER IN CASE IT IS NECESSARY TO CONTACT YOU REGARDING YOUR BID: ----- 724-837-5425 -----</p> <p>CONTACT PERSON (PLEASE PRINT CLEARLY): ----- DENNIS CUNNINGHAM -----</p> <p>***** THIS IS THE END OF RFQ MOC17199 ***** TOTAL: \$ 27,758.⁰⁰</p>						

SEE REVERSE SIDE FOR TERMS AND CONDITIONS

SIGNATURE <i>[Signature]</i>	TELEPHONE 724-837-5411	DATE 5/21/07
TITLE SALES DIRECTOR	FEIN 22-2964823	ADDRESS CHANGES TO BE NOTED ABOVE

WHEN RESPONDING TO RFQ, INSERT NAME AND ADDRESS IN SPACE ABOVE LABELED 'VENDOR'

MOC17199 – COMPACT MOBILE X-RAY MACHINE SPECIFICATIONS

The X-Ray machine (hereinafter referred to as “machine”) shall be a high capacity parcel model Autoclear 6848M, or equal. Machine will be used in a maximum security prison. Should an equal be bid, any literature, colored brochures, and/or specification sheets shall be provided. The machine shall have the minimum specifications as stated:

- **68.0 CM Wide X 48.0 CM high; or 26.8” Wide X 18.9” high tunnel opening**
- **High capacity; High penetration; Heavy duty, conveyor-type x-ray scanner designed to inspect carry-on bags, briefcases, mail trays, and parcels.**
- **Must fit in elevators, 36” doorways and other tight spaces**
- **Conveyor end must fold up for transport to be used in other high critical areas in a timely situation**
- **Multi-energy color option with organic/in-organic stripping**
- **Tip, training, and image archiving must be supplied**
- **Option highlights suspect materials using atomic number & density**
- **Bid price must include shipping and a minimum one (1) year parts and labor warranty**
- **Delivery must be made by 7/1/2007 – so long as the purchase order has been received by the vendor from the State of West Virginia by 6/1/2007. The number of days after 6/1/2007 will be the number of days the vendor will have to deliver the machine**
- **Notes to remember: Please complete the attached “Purchasing Affidavit”, sign the bid, and provide the requested information on the Request for Quotation. If the vendor is not registered with the Division of Purchasing, please contact Jeanne Barnhart at (304) 558-2311 to become registered; so should an award be made, the delivery will not become an issue. Vendors may also call Ms. Barnhart to determine if they are current with the Purchasing Division.**

Control Screening

Manufacturers of autoClear® • Scintrex Trace®
CheckGate® • Federal Labs® • Dynavision®

May 21, 2007

Division of Corrections
Mount Olive Correctional Center
One Mountainside Way
Mt. Olive, WV 25185

Ref: RFQ # MOC17199

Gentlemen:

Please find enclosed our complete response for the compact, portable X-ray machine that is specified in the referenced RFQ. We are providing the AUTOCLEAR Model 6848-M. The total price that we have bid includes all of the following listed items and conditions:

- 68.0 CM wide x 48.0 CM high; or 26.8 wide x 18.9" high tunnel opening
- High capacity; high penetration; heavy duty, conveyor-type X-ray scanner designed to inspect carry-on bags, briefcases, mail trays and parcels
- Overall width 34.7", so the unit fits in elevators, 36" doorways and other tight spaces
- Conveyor end folds up for transport to be used in other high critical areas in a timely situation
- Multi-energy color option with organic/inorganic stripping
- Tip, training and image archiving is supplied
- AutoMatalert highlights suspect materials using atomic number & density and is supplied
- Bid price ncludes shipping and a minimum one (1) year parts and labor warranty
- Delivery will be made by 7/1/2007 – so long as the purchase order has been received by Control Screening from the State of West Virginia by 6/1/2007. The number of days after 6/1/2007 will be the number of days the vendor will have to deliver the machine.

We look forward to serving your facility's need for this important piece of security equipment.

If you have any questions or need more information, please do not hesitate to contact us at 1-800-343-9727 or email dcunningham@controlscreening.com.

Best regards,
Control Screening / AUTOCLEAR



BY: Dennis Cunningham

Sales Director

35 W. Pittsburgh St., P.O. Box 1142, Greensburg, PA 15601-2323

Tel: (724) 837 – 5411 Fax: (724) 837 – 5425 email: pa@controlscreening.com

AUTOCLEAR 6848

High Capacity Parcel X-ray for Explosives, Weapons & Narcotics

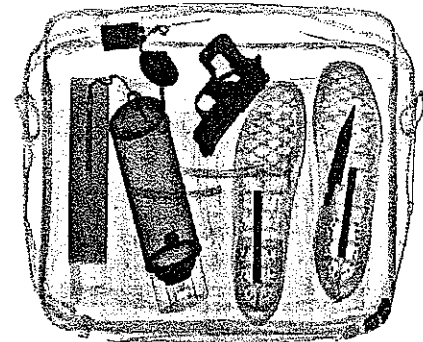
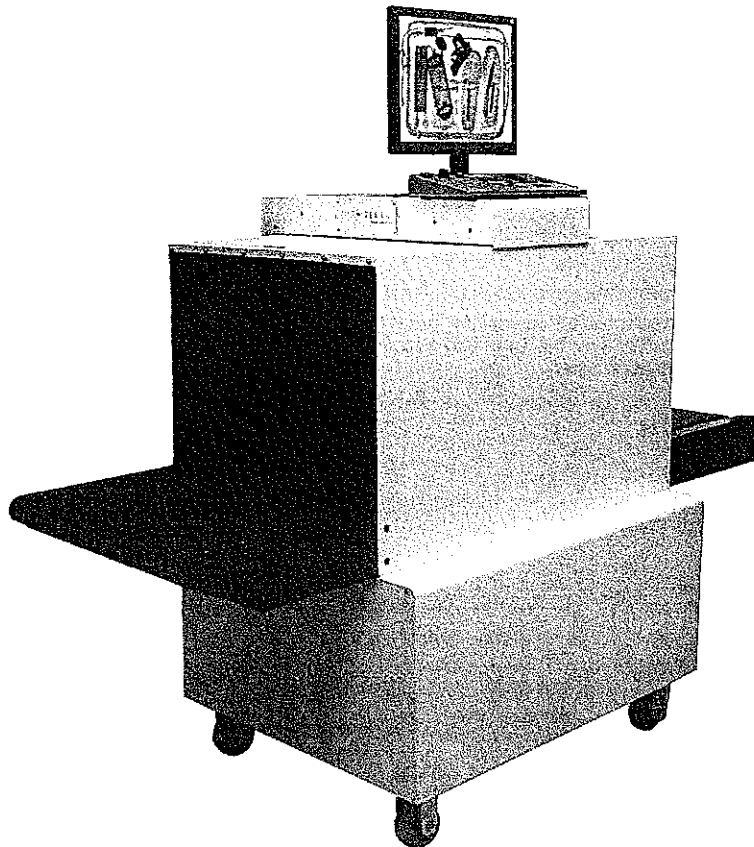

RealClear[®] reveals components of a gun, knife and bomb in real time, without lags and delays autoScale[®] displays contents at Pentium 4 resolution automatically and without distortion.

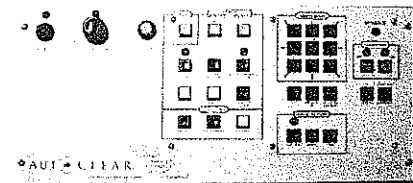

User-friendly, ergonomic and fully-featured operator control panel

Control Screening is the leading worldwide producer of fast, reliable and sophisticated X-ray, Metal and Trace Detection screening systems. Visit us at www.controlscreening.com. Ask about our mobile and cargo systems. Our advanced systems and options are often integrated, leased or rented.

The AUTOCLEAR[®] 6848 (featuring a 68.0 cm wide x 48.0 cm high or 26.8" wide x 18.9" high tunnel opening) is a high capacity, high penetration, heavy-duty, conveyorized X-ray scanner designed to inspect carry-on bags, briefcases, mail trays and parcels. Ideal for use at:

**Airports • Seaports • Courts
Customs • Corporate Facilities
Government Buildings • Postal
Checkpoints • Loading Docks
Mailrooms • Corrections Facilities
Nuclear • Access Control
Special Events • Hospitals
Rail or Bus Stations
Police Stations • Military Bases**

Features

- ⇒ autoTracking[®] guided conveyor belt system never needs adjustment, lowering operating costs
- ⇒ autoSensing[®] eliminates the need for troublesome photosensors or footpad switch. Assures 100% screening of thin blades or plastic in magazines or courier envelopes, or of bag already in tunnel at start-up
- ⇒ Parcel contents are displayed at normal scale, wherever located, automatically and without distortion (autoScale[®]). RealClear[®] function reveals components of dense items in realtime without lags or delays.
- ⇒ Narrower footprint enhances security and conveniently fits in elevators, 36" doorways and tight spaces; conveyor end folds up for transport
- ⇒ Features Pentium 4, 17" monitor RealClear[®], autoScale[®], autoDensAlert[®], autoOutline[®], autoSensing[®], autoCal[®], 64X Smart Zoom, Lighten, Help, DensityScan, and Low Density Stripping, among other features
- ⇒ Compact version (above) or airport version with extended conveyor(s).
- ⇒ Multi-Energy Color option with Organic/Inorganic Stripping is popular. TIP, Training and Image Archiving also available. auto-Matalert[®], option highlights suspect materials using atomic number and density
- ⇒ Interactive training and highly responsive local service. Engineered, made and rigorously tested in the USA to ISO 9001 and regulatory standards

Celebrating 70 years of excellence in design & support

AUTOCLEAR

autoclearus.com

Scintrex[®] • Federal Labs[®] • CheckGate[®] • CPAD • Control Screening
U.S. Canada France Spain Dubai Latin America Singapore

Model 6848 X-ray Specifications

Overall Dimensions: Inspection Capabilities

185.4 cm (73.0") L x 88.1 cm (34.7") W x 132.7 cm (52.3") H

Tunnel Size:

26.8" wide (68 cm)
18.9" high (48 cm)
L-shaped detector for 100% package screening

Material Penetration:
Contrast Sensitivity:
Resolution:
Processing:

28-29 mm steel
Over 2 million color tones standard
40 AWG wire
32-bit adaptive image processing with minimum 128 Mbytes memory; 800 MHz or 2.4 GHz processor.

Conveyor Speed:

48 feet per minute; 24 cm per second. Standard conveyor pictured on reverse. Extended conveyor length, Model 6040E (variable length entrance and exit bed) Fully reversible

Pulling Weight:
autoTracking™:
Film Safety:

150 kg (331 lbs) (Higher pulling weights available)
Belt guaranteed to autoTrack for life
Guaranteed for high-speed films up to ISO 1600 (33 DIN)

***Full autoSensing® without photosensors, moving parts, or footpad.**

Reduces downtime and assures all magazines, envelopes or items are scanned, no matter how thin, or of bag already in tunnel at start-up. Enhances radiation safety.

X-ray Generator

X-ray tube head:
High voltage rating:
Duty cycle:
Beam orientation:
Dose rate per exam:

Self-contained, shielded tank
160 kV, 140 kV Operating Voltage
100% with sealed oil bath cooling
Diagonal
0.1 mR Lower doses available

X-ray Detectors

Surface mounted, multilayer, fully integrated, high frequency solid state detectors using high speed processors, and Pentium 4 image processing with Single Energy or optional Multi-Energy (M) Color.

Video

Standard with color 17" SVGA monitor High resolution, flicker-free 21 dot pitch, low rad. monitor, 1280 x 1024 video card Single energy color is based on object density Multi-Energy color option available with available second monitor or flat screen or larger monitor(s), displays organics in orange and inorganics in blue, both overlapping in green and very dense objects in black, and includes Organic and Inorganic Stripping

Standard Features

- RealClear™
- autoDensAlert™
- autoTracking™
- autoSensing™
- autoOutline™
- autoScale™
- autoCal™
- Dark & Light enhance
- DensityScan
- Color; Reverse B/W
- High/Low Density & Stripping
- High density
- Help
- Fast (25 second) initial warm-up
- Fully functional, robust, low profile
- Reversible conveyor direction

Options

- Multi-Energy organic and inorganic color & stripping
- autoMataAlert™
- Threat Image Projection (TIP)
- Rollerbed(s) or conveyor extensions
- Tropical Humidity Kit
- Image Archiving
- CE marking or UK approved
- Power conditioner, or UPS
- Table or locking monitor hood
- Locking metal keypad cover
- kV, mA meter or item counter
- LCD, dual or larger monitor(s)
- Footpad or optical on/off
- Variable height keypad mount
- Clear Lexan conveyor guard
- Remote, printer or VCR cable
- Built-in Training
- Rentals or leases
- autoNet
- TipNet

Physical Details

Dimensions: See drawing
Weight: 890 lbs (403 kg)
1150 lbs (517 kg) crated
Construction: Unibody heavy gauge epoxy painted steel construction with stainless steel and aluminum trim and accessories Non-marring casters and leveling jackscrews. Corrosion-resistant command center keypad mounted on side or on available table

Environmental Conditions: Temperature range: 32° - 104° F, (0° - 40° C)
Humidity 20% - 95%, non-condensing
Storage to 65° C (149° F)

Electrical Power Requirements: Consumption: < .6 kVA, 120 volts AC ± 10% (-6 amps)
200, 220, 240 250 volts AC ± 10% (<3 amps)
All at 50 or 60 Hz

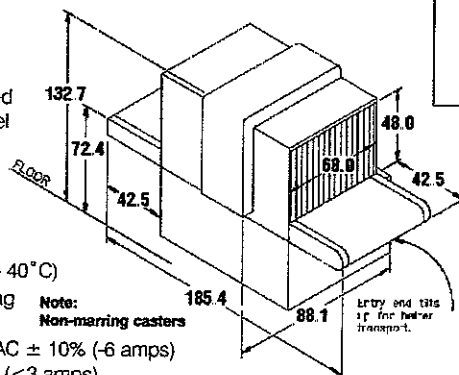

Dimensions are in centimeters

www.autoclearus.com

World Headquarters Plant
2 Gardner Road
Fairfield, NJ 07004-2206 USA
Tel: + 1 (973) 276-6161
Fax: + 1 (973) 276-6162
leads@autoclearus.com

Western U.S.

nw@autoclearus.com
sw@autoclearus.com

Continental Europe

France

Tel: + 33 2 38 61 97 00
Fax: + 33 2 38 61 97 01
eu@autoclearus.com

Spain, Italy, Mediterranean

Tel/Fax: +34 91 650 89 86
lghedina@autoclearus.com

Canada

Scintrex Trace Plant

300 Parkdale Ave., Ottawa
Ontario, Canada K1Y 1G2
Tel: + 1 (613) 224-1061
Fax: + 1 (613) 224-2603
info@autoclearus.com

Asia

Singapore
asia@autoclearus.com

Latina/América Central

Dominican Republic
latina@autoclearus.com

Middle East

Dubai, UAE
ME@autoclearus.com

Distributor:

ISO 9001-2000 registered

www.autoclearus.com
www.tracedetection.com www.fed-labs.com

Celebrating 70 years of excellence in design & support

AUTOCLEAR
autoclearus.com

Scintrex™ Federal Labs™ CheckGate™ CPAD™ Control Screening
U.S. Canada France Spain Dubai Latin America Singapore

STATE OF WEST VIRGINIA
Purchasing Division**PURCHASING AFFIDAVIT**

West Virginia Code §5A-3-10a states: No contract or renewal of any contract may be awarded by the state or any of its political subdivisions to any vendor or prospective vendor when the vendor or prospective vendor or a related party to the vendor or prospective vendor is a debtor and the debt owned is an amount greater than one thousand dollars in the aggregate

DEFINITIONS:

"Debt" means any assessment, premium, penalty, fine, tax or other amount of money owed to the state or any of its political subdivisions because of a judgment, fine, permit violation, license assessment, defaulted workers' compensation premium, penalty or other assessment presently delinquent or due and required to be paid to the state or any of its political subdivisions, including any interest or additional penalties accrued thereon.

"Debtor" means any individual, corporation, partnership, association, limited liability company or any other form or business association owing a debt to the state or any of its political subdivisions. "Political subdivision" means any county commission; municipality; county board of education; any instrumentality established by a county or municipality; any separate corporation or instrumentality established by one or more counties or municipalities, as permitted by law; or any public body charged by law with the performance of a government function or whose jurisdiction is coextensive with one or more counties or municipalities. "Related party" means a party, whether an individual, corporation, partnership, association, limited liability company or any other form or business association or other entity whatsoever, related to any vendor by blood, marriage, ownership or contract through which the party has a relationship of ownership or other interest with the vendor so that the party will actually or by effect receive or control a portion of the benefit, profit or other consideration from performance of a vendor contract with the party receiving an amount that meets or exceeds five percent of the total contract amount.

EXCEPTION: The prohibition of this section does not apply where a vendor has contested any tax administered pursuant to chapter eleven of this code, workers' compensation premium, permit fee or environmental fee or assessment and the matter has not become final or where the vendor has entered into a payment plan or agreement and the vendor is not in default of any of the provisions of such plan or agreement.

LICENSING: Vendors must be licensed and in good standing in accordance with any and all state and local laws and requirements by any state or local agency of West Virginia, including, but not limited to, the West Virginia Secretary of State's Office, the West Virginia Tax Department, West Virginia Insurance Commission, or any other state agencies or political subdivision. Furthermore, the vendor must provide all necessary releases to obtain information to enable the Director or spending unit to verify that the vendor is licensed and in good standing with the above entities.

CONFIDENTIALITY: The vendor agrees that he or she will not disclose to anyone, directly or indirectly, any such personally identifiable information or other confidential information gained from the agency, unless the individual who is the subject of the information consents to the disclosure in writing or the disclosure is made pursuant to the agency's policies, procedures and rules. Vendors should visit www.state.wv.us/admin/purchase/privacy for the Notice of Agency Confidentiality Policies.

Under penalty of law for false swearing (West Virginia Code, §61-5-3), it is hereby certified that the vendor acknowledges the information in this said affidavit and are in compliance with the requirements as stated.

Vendor's Name: CONTROL SCREENING LLC

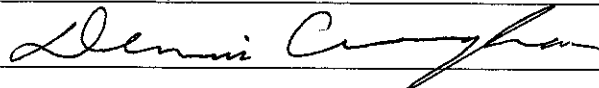
Authorized Signature:  Date: 5/21/07