

•  
•  
•  
•  
•  
•  
•  
•

RCS COMMUNICATIONS  
ROBERT C. SHOOK  
PRESIDENT  
322 LOTS GAP RD  
MAX MEADOWS VA 24360  
Telephone 276-223-1551  
Fax 276-223-4435  
EMAIL [rcscomm@maxs.net](mailto:rcscomm@maxs.net)

August 11, 2006

Mr. Chuck Bowman  
Purchasing Division  
2019 Washington St. East  
PO Box 50130  
Charleston WV 25305

Dear Sir,

Enclosed please find our response to your RFQ # HSE06074 for Flood Control Devices and Equipment Servicing.

We have also attached a brief resume' and a list of servicing equipment available for the project in an effort to confirm our eligibility, expertise and capability for performing all of the requested tasks as described in the RFQ. Additionally, we have attached copies of some of our relevant technical certifications.

We hope you find everything to be in order, however if there are any questions or clarifications necessary, please do not hesitate to call.

Respectfully,

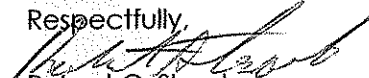

Robert C. Shook

• • • • •



RCS COMMUNICATIONS  
ROBERT C. SHOOK  
PRESIDENT  
322 LOTS GAP RD  
MAX MEADOWS VA 24360  
Telephone 276-223-1551  
Fax 276-223-4435  
EMAIL [rcscomm@naxs.net](mailto:rcscomm@naxs.net)

## RCS COMMUNICATIONS

### COMPANY INFORMATION

**RCS** Communications, incorporated in 1998, was originally established to meet the unique communications needs of real time hydrological data dissemination. These particular requirements of various emergency management programs are primarily associated with flash flood warning systems. Drawing upon expertise developed over a quarter of a century in land mobile communications, RCS has successfully provided installation and engineering services for **Radio Controlled Systems** to many customers in the Flood Warning community, including the National Weather Service, US Army Corps of Engineers, VA Department of Emergency Management, WV Office of Emergency Services, PEMA, FEMA and KY Office of Emergency Management. Similar services have also been provided to Prince George's Co. MD and North Carolina Emergency Services.

**RCS** is also active in the land mobile and public safety communications industry. Some of our customers include the Ivanhoe Volunteer Fire Dept, VA State Police, Twin County Airport, Tazewell County Airport, TN Department of Aviation, HT Bowling, Christiansburg Fire & Rescue, Grayson Co. Sheriff and Pegasus Tower Co.

**RCS** is a fully licensed and qualified Class A Electrical Contractor, License # 2705 057 100A, in the State of Virginia and has extensive experience with the FAA, FCC and aviation lighting and control systems. We are well acquainted with grounding and bonding requirements of antenna structures, communications and other electrical systems.

A complete customer list, personnel qualification statements and individual resumé's are available upon request.



•  
•  
•  
•  
•  
•  
•

RCS COMMUNICATIONS  
ROBERT C. SHOOK  
PRESIDENT  
322 LOTS GAP RD  
MAX MEADOWS VA 24360  
Telephone 276-223-1551  
Fax 276-223-4435  
EMAIL [rcscomm@naxs.net](mailto:rcscomm@naxs.net)

August 7, 2006

## **IFLOWS/ALERT RAIN & STREAM AUTOMATED GAGE SYSTEM**

### **Servicing Equipment Requirements**

#### **Field Tech w/ 4WD Vehicle**

Minimum onboard equipment to provide customer with maximum cost/benefit ratio.

- Digital VOM
- RF Wattmeter
- Antenna Analyzer (MFJ 269 or equiv.)
- Laptop Computer w/ Windows 98 (or XP....2000 is not recommended), Vaisala 555 IFLOWS46 & Maintenance Tracker software installed. HS3300 software also required for repeater servicing . 555 interface cable.
- 300 bd decoder modem w/ 169.500, 169.475 & 171.875 Rx - Serial data cables
- PT Pressure Calibration unit w/adapters and clamps.
- GPS receiver (mapping software optional)
- Cell Phone and/or VHF Radio for real time confirmation of signal.
- 71.9 cc measuring device w/water for static TB Cal.
- Bottle Brush for cleaning funnels
- Hand Tools incl. tape measure, drill, hacksaw, wrenches, crimpers, shovel, digging bar, etc.
- Power Chain Saw or Bow Saw plus Extendable Tree Limb Cutter
- Silicon Caulk
- Wasp and Bee spray
- Misc. expendables - electrical & duct tape, butt splices, wire, hose clamps etc.
- 2 ton come along w/chain or tow strap
- 8' stepladder
- 16' extension ladder
- Spare Parts ( transmitters, solar panels, shaft encoder, antennas & coax, batteries)

#### **For Bench Repair and Support**

REQUIRED TEST EQUIPMENT TOOLS & SUPPLIES

- RF Service monitor (IFR1200 or equivalent.)
- 300 baud decoder modem w/ 169.500, 169.475, 171.875 Rx - Serial data cables
- Computer w/ Windows 98, IFLOWS46, Vaisala 555 and Maintenance Tracker Software,
- Vaisala 555 interface cable
- Solder/Desolder Station
- Oscilloscope 100/mhz or higher
- Digital VOM
- DC Battery Charger/ Discharger (capable of cycling/testing up to 5 batteries/day)
- Access to battery disposal depot
- Test PT attachment

.....

**ROBERT C. SHOOK**  
322 LOT'S GAP RD  
MAX MEADOWS, VA 24360  
(276) 223-1551  
FCC License # PG-5-10569  
Master Electrician License # 2710-004973

## **SUMMARY OF PROFESSIONAL EXPERIENCE**

- January 1998 - Present - President and Operational Manager of RCS Communications, a wholly owned subsidiary of 3B's Inc. A licensed Class "A" Electrical Contractor in VA.

RCS is involved in various markets, including the specialized communications concepts involved in the wide area dissemination of flood warning and hydrological data. We are also active in the TWO WAY or Land Mobile area with several fire departments and business band customers. RCS Communications installs and maintains various types of data collection and communications systems throughout the east coast. Customers include the National Weather Service Office of Hydrology, NWS Eastern Region Headquarters, Virginia Department of Emergency Services, Army Corps of Engineers, WV Office of Emergency Services, KY Emergency Management Agency and others in the Flood Warning/Emergency Preparedness community. As a fully certified Class "A" contractor, RCS also has installed and maintains airport systems such as Automated Weather Systems, airfield lighting and navigational beacons.

RCS also provides tower services to the communications industry with factory trained expertise in Honeywell Systems and extensive experience with other systems including HARK and FLASH.

- August 1995 - December 1997 - Vice-President, Senior Electronics Technician Electrotech Contracting, Inc., Wytheville, VA

Filled position as Qualified Master Electrician and Lead Foreman for construction crew. Responsibilities included daily onsite management of construction projects, tower installations, project planning and cost estimation for bidding purposes,

- October 1993 – June 1995 - Project Representative for Delta Airport Consultants, Richmond VA.

Filled position of onsite project representative for Airfield security and access control system at Byrd International Airport, Richmond VA. Provided oversight duties to facilitate the implementation of the new system. Also provided liaison for the contractor's interface with engineer and airport personnel.

- 1979 - October 1993 - Electronics Technician & Master Electrician Two Way Radio, Inc., Wytheville, VA

Actively involved with design, installation and maintenance of Radio Reporting Rain and Stream gauges since the conception of IFLOWS (Integrated Flood

Observation and Warning System) in 1979. IFLOWS is a network of 250 computers and 1700 rainfall and stream stage sensors connected via wireless communications backbone equipment, which utilizes VHF, UHF transceivers and microwave systems, in 12 states. Maintain 33 Handar Automated Weather Observation Systems (AWOS). Install and maintain 12 AAI/SMI Next Generation Automated Weather Observation Systems (NEXWOS). Certified Master Electrician and fills position as Qualified Electrician for VA Class "A" Contractor. Specialized in Airport Lighting and Aviation Navigational Aid Systems.

Factory certified Motorola and Land Mobile radio repair and installation, servicing customers in the Public Safety and Business Band field. Project Manager for over 20 Airport Lighting and Navigational Aid projects. Filled position as Qualified Master Electrician and Lead Foreman for construction crew. Responsibilities included daily onsite management of construction projects, tower installations, project planning and cost estimation for bidding purposes, and engineering/maintenance for mobile radio systems.

- 1967 - 1973 - Radio Communications Technician - ETN2, U.S. Navy

Shop supervisor for Fleet Tender Repair facility.  
Performed as penultimate resource for electronics systems repair prior to shipyard services.

## **EDUCATION**

2001 – Vaisala AWOS V-C/V-B Columbus OH.

1995 - AAI/Systems Management, Inc.

Next Generation Automated Weather Observation System (NEXWOS)  
Maintenance Course

1987 - Handar Automated Weather Observation System Maintenance Course

1969 - 1973 - Various Equipment Schools including: UHF Transceivers, HF Transmitters, Multiport modem systems, Facsimile receivers.

1969 - Electronics Class A Schools USN Great Lakes IL

1967 - Diploma - Parkersburg High School, Parkersburg, WV

## **CERTIFICATES & LICENSES**

FCC General Radiotelephone PG-5-10569

WV Electrical Journeyman J05473

VA Class A Contractor

FCC Amateur Radio KD4EXE

FAA Certified AWOS Technician

# The United States of America

## Federal Communications Commission

### GENERAL RADIOTELEPHONE OPERATOR LICENSE

(General Radiotelephone Certificate)

This certifies that the individual named below is a licensed radio operator and is authorized to operate licensed radio stations for which this class of license is valid. The authority granted is subject to any endorsement placed on this license. The authority granted is also subject to the orders, rules, and regulations of the Federal Communications Commission, the statutes of the United States, and the provision of any treaties to which the United States is a party, which are binding upon radio operators.

This license may not be assigned or transferred to any other person. This license is valid for the lifetime of the holder unless suspended by the FCC.

Endorsement:

**NONE**

Licensee: ROBERT C. SHOOK JR

Date of Birth	Issuance Date	Place of Issuance
JUNE 26, 1949	JANUARY 2, 1985	NORFOLK, VA.
		License Number
		PG-5-10569

*Robert C. Shook Jr*

Signature of Licensee



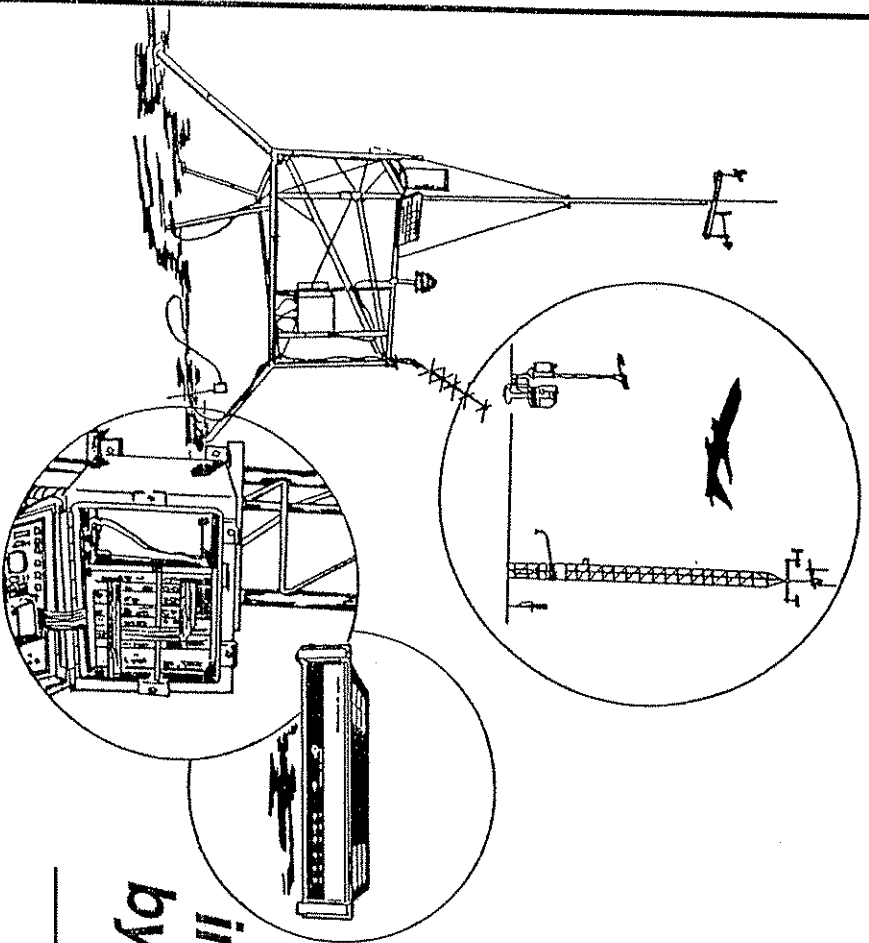

# Handar

is pleased to Certify that

Robert C. Shook

**has passed the FAA  
approved requirements  
established by Handar  
to perform AWOS  
installation and maintenance  
by successfully completing the**

AWOS Training Class

Module One, Module Two, & Module Three

**Dated**

December 10, 1987

*William Waters*

William Waters, HANDAR AWOS Sales Manager

*Kathryn Miles-Schlitting*

Kathryn Miles-Schlitting, AWOS Product Support

**Ray N. Fletcher**  
1085 HOLSTON RD.  
WYTHEVILLE, VA 24385  
(276) 223-2552  
FCC License # PG-5-3791  
Amateur Radio License # WD4MUQ

## **SUMMARY OF PROFESSIONAL EXPERIENCE**

- January 2001 - Present – Chief Electronics Technician for RCS Communications, a wholly owned subsidiary of 3B's Inc. a licensed Class "A" Electrical Contractor in VA.  
  
RCS is involved in various markets, including the specialized communications concepts involved in the wide area dissemination of flood warning and hydrological data. We are also active in the TWO WAY or Land Mobile area with several fire departments and business band customers. RCS Communications installs and maintains various types of data collection and communications systems throughout the east coast. Customers include the National Weather Service Office of Hydrology, NWS Eastern Region Headquarters, Virginia Department of Emergency Services, Army Corps of Engineers, WV Office of Emergency Services, KY Emergency Management Agency and others in the Flood Warning/Emergency Preparedness community. As a fully certified Class "A" contractor, RCS also has installed and maintains airport systems such as Automated Weather Systems, airfield lighting and navigational beacons.  
RCS also provides tower services to the communications industry with factory trained expertise in Honeywell Systems and extensive experience with other systems including HARK and FLASH.
- Sept 1975 – December 2000 - Senior Electronics Technician Two Way Radio Inc. Wytheville, VA  
  
Filled position as Senior repair technician and shop supervisor for Beckley WV and Hazard KY. Assigned duties as lead repairman for bench and field radio systems repairs. During this period attended many different technical and training schools for Motorola and GE equipments including Motrac, Mocom 70, Maxtrac, Micor, Mitrex, Radius, MSR 2000, Master Pro, Master II, Series 90 Controllers, Starplex and Starpoint Microwave Systems and others. Graduated Wilcox Training Academy and FAA certified as repairman for ILS Systems.  
  
Actively involved with design, installation and maintenance of Radio Reporting Rain and Stream gauges since the conception of IFLOWS (Integrated Flood Observation and Warning System) in 1979. IFLOWS is a network of 250 computers and 1700 rainfall and stream stage sensors connected via wireless communications backbone equipment, which utilizes VHF, UHF transceivers and microwave systems, in 12 states. Maintain 33 Handar Automated Weather Observation Systems (AWOS).
- August 1971 – August 1975 - US AIR FORCE  
  
Electronics and Radar repair billets in various Radar sites in eastern USA.



Honorable Discharge – August 1975

## **EDUCATION**

2001 – Vaisala AWOS V-C/V-B Columbus OH.

1993 - AAI/Systems Management, Inc.

Next Generation Automated Weather Observation System (NEXWOS)  
Maintenance Course

1991 – Wilcox ILS Localizer & DME

1989 – FAA Academy – Oklahoma City OK. ILS Systems

1987 - Handar Automated Weather Observation System Maintenance Course

1971 - 1973 - Various Equipment Schools including: UHF Transceivers, HF  
Transmitters, Multiprot modem systems, Facsimile receivers. TOP Secret  
Clearance

1968 – 1971 - WCC Civil Engineering

1968 – Bland High School Graduated with Diploma

## **CERTIFICATES & LICENSES**

FCC General Radiotelephone PG-5-3791

FCC Amateur Radio WD4MUQ

FAA Certified AWOS Technician



State of West Virginia  
 Department of Administration  
 Purchasing Division  
 2019 Washington Street East  
 Post Office Box 50130  
 Charleston, WV 25305-0130

# Request for Quotation

RFQ NUMBER
HSE06074

PAGE
1

ADDRESS CORRESPONDENCE TO ATTENTION OF:
CHUCK BOWMAN 304-558-2157

VENDOR

\*829083300      540-223-1551  
 RCS COMMUNICATIONS  
 322 LOTS GAP ROAD  
  
 MAX MEADOWS VA 24360

SHIP TO

HOMELAND SECURITY & EMERGENCY  
 MANAGEMENT, DIVISION OF  
 BUILDING 1, ROOM EB80  
 1900 KANAWHA BOULEVARD, EAST  
 CHARLESTON, WV  
 25305-0360      304-558-5380

DATE PRINTED	TERMS OF SALE	SHIP VIA	F.O.B.	FREIGHT TERMS
07/19/2006				

BID OPENING DATE: **08/16/2006**      BID OPENING TIME **01:30PM**

LINE	QUANTITY	UOP	CAT NO	ITEM NUMBER	UNIT PRICE	AMOUNT
0001	1	HR		578-37		
<p>FLOOD CONTROL DEVICES AND EQUIPMENT</p> <p>THE WEST VIRGINIA PURCHASING DIVISION, ON BEHALF OF THE AGENCY, THE WEST VIRGINIA DIVISION OF HOMELAND SECURITY AND EMERGENCY MANAGEMENT, IS SOLICITING BIDS FROM QUALIFIED VENDORS TO PROVIDE TECHNICAL SUPPORT IN THE MAINTENANCE, REPAIR, AND EXPANSION OF THE STATE FLOOD WARNING SYSTEM, PER THE FOLLOWING SCOPE OF WORK, GENERAL CONDITIONS, BID REQUIREMENTS, TERMS &amp; CONDITIONS, AND THE ATTACHED SPECIFICATION AND BID SCHEDULE.</p> <p>EXHIBIT 3</p> <p>LIFE OF CONTRACT: THIS CONTRACT BECOMES EFFECTIVE UPON AWARD AND EXTENDS FOR A PERIOD OF ONE (1) YEAR OR UNTIL SUCH "REASONABLE TIME" THEREAFTER AS IS NECESSARY TO OBTAIN A NEW CONTRACT OR RENEW THE ORIGINAL CONTRACT. THE "REASONABLE TIME" PERIOD SHALL NOT EXCEED TWELVE (12) MONTHS. DURING THIS "REASONABLE TIME" THE VENDOR MAY TERMINATE THIS CONTRACT FOR ANY REASON UPON GIVING THE DIRECTOR OF PURCHASING 30 DAYS WRITTEN NOTICE.</p> <p>UNLESS SPECIFIC PROVISIONS ARE STIPULATED ELSEWHERE IN THIS CONTRACT DOCUMENT, THE TERMS, CONDITIONS AND PRICING SET HEREIN ARE FIRM FOR THE LIFE OF THE CONTRACT.</p> <p>RENEWAL: THIS CONTRACT MAY BE RENEWED UPON THE MUTUAL</p>						

SEE REVERSE SIDE FOR TERMS AND CONDITIONS

SIGNATURE <i>Robert A. Howard</i>	TELEPHONE 540-223-1551	DATE 8/11/06
TITLE PRESIDENT	FEIN 54-1864058	ADDRESS CHANGES TO BE NOTED ABOVE

WHEN RESPONDING TO RFQ, INSERT NAME AND ADDRESS IN SPACE ABOVE LABELED 'VENDOR'

**GENERAL TERMS & CONDITIONS  
REQUEST FOR QUOTATION (RFQ) AND REQUEST FOR PROPOSAL (RFP)**

1. Awards will be made in the best interest of the State of West Virginia.
2. The State may accept or reject in part, or in whole, any bid.
3. All quotations are governed by the *West Virginia Code* and the *Legislative Rules* of the Purchasing Division.
4. Prior to any award, the apparent successful vendor must be properly registered with the Purchasing Division and have paid the required \$125.00 registration fee.
5. All services performed or goods delivered under State Purchase Orders/Contracts are to be continued for the term of the Purchase Order/Contract, contingent upon funds being appropriated by the Legislature or otherwise being made available. In the event funds are not appropriated or otherwise available for these services or goods, this Purchase Order/Contract becomes void and of no effect after June 30.
6. Payment may only be made after the delivery and acceptance of goods or services.
7. Interest may be paid for late payment in accordance with the *West Virginia Code*.
8. Vendor preference will be granted upon written request in accordance with the *West Virginia Code*.
9. The State of West Virginia is exempt from federal and state taxes and will not pay or reimburse such taxes.
10. The Director of Purchasing may cancel any Purchase Order/Contract upon 30 days written notice to the seller.
11. The laws of the State of West Virginia and the *Legislative Rules* of the Purchasing Division shall govern all rights and duties under the Contract, including without limitation the validity of this Purchase Order/Contract.
12. Any reference to automatic renewal is hereby deleted. The Contract may be renewed only upon mutual written agreement of the parties.
13. **BANKRUPTCY:** In the event the vendor/contractor files for bankruptcy protection, this contract is automatically null and void, and is terminated without further order.
14. **HIPAA Business Associate Addendum** - The West Virginia State Government HIPAA Business Associate Addendum (BAA), approved by the Attorney General, and available online at the Purchasing Division's web site (<http://www.state.wv.us/admin/purchase/vrc/hipaa.htm>) is hereby made part of the agreement. Provided that, the Agency meets the definition of a Covered Entity (45 CFR §160.103) and will be disclosing Protected Health Information (45 CFR §160.103) to the vendor.

---

**INSTRUCTIONS TO BIDDERS**

1. Use the quotation forms provided by the Purchasing Division.
2. **SPECIFICATIONS:** Items offered must be in compliance with the specifications. Any deviation from the specifications must be clearly indicated by the bidder. Alternates offered by the bidder as **EQUAL** to the specifications must be clearly defined. A bidder offering an alternate should attach complete specifications and literature to the bid. The Purchasing Division may waive minor deviations to specifications.
3. Complete all sections of the quotation form.
4. Unit prices shall prevail in cases of discrepancy.
5. All quotations are considered F.O.B. destination unless alternate shipping terms are clearly identified in the quotation.
6. **BID SUBMISSION:** All quotations must be delivered by the bidder to the office listed below prior to the date and time of the bid opening. Failure of the bidder to deliver the quotations on time will result in bid disqualifications.

**SIGNED BID TO:**

Department of Administration  
Purchasing Division  
2019 Washington Street East  
Post Office Box 50130  
Charleston, WV 25305-0130



State of West Virginia  
 Department of Administration  
 Purchasing Division  
 2019 Washington Street East  
 Post Office Box 50130  
 Charleston, WV 25305-0130

# Request for Quotation

RFQ NUMBER  
**HSE06074**

PAGE  
**2**

ADDRESS CORRESPONDENCE TO ATTENTION OF:  
**CHUCK BOWMAN**  
**304-558-2157**

VENDOR

\*829083300      540-223-1551  
 RCS COMMUNICATIONS  
 322 LOTS GAP ROAD  
 MAX MEADOWS VA 24360

SHIP TO

HOMELAND SECURITY & EMERGENCY  
 MANAGEMENT, DIVISION OF  
 BUILDING 1, ROOM EB80  
 1900 KANAWHA BOULEVARD, EAST  
 CHARLESTON, WV  
 25305-0360      304-558-5380

DATE PRINTED	TERMS OF SALE	SHIP VIA	F.O.B.	FREIGHT TERMS
07/19/2006				

BID OPENING DATE: **08/16/2006**      BID OPENING TIME **01:30PM**

LINE	QUANTITY	UOP	CAT NO.	ITEM NUMBER	UNIT PRICE	AMOUNT
<p>WRITTEN CONSENT OF THE SPENDING UNIT AND VENDOR, SUBMITTED TO THE DIRECTOR OF PURCHASING THIRTY (30) DAYS PRIOR TO THE EXPIRATION DATE. SUCH RENEWAL SHALL BE IN ACCORDANCE WITH THE TERMS AND CONDITIONS OF THE ORIGINAL CONTRACT AND SHALL BE LIMITED TO TWO (2) ONE (1) YEAR PERIODS.</p> <p>CANCELLATION: THE DIRECTOR OF PURCHASING RESERVES THE RIGHT TO CANCEL THIS CONTRACT IMMEDIATELY UPON WRITTEN NOTICE TO THE VENDOR IF THE COMMODITIES AND/OR SERVICES SUPPLIED ARE OF AN INFERIOR QUALITY OR DO NOT CONFORM TO THE SPECIFICATIONS OF THE BID AND CONTRACT HEREIN.</p> <p>OPEN MARKET CLAUSE: THE DIRECTOR OF PURCHASING MAY AUTHORIZE A SPENDING UNIT TO PURCHASE ON THE OPEN MARKET, WITHOUT THE FILING OF A REQUISITION OR COST ESTIMATE, ITEMS SPECIFIED ON THIS CONTRACT FOR IMMEDIATE DELIVERY IN EMERGENCIES DUE TO UNFORESEEN CAUSES (INCLUDING BUT NOT LIMITED TO DELAYS IN TRANSPORTATION OR AN UNANTICIPATED INCREASE IN THE VOLUME OF WORK.)</p> <p>QUANTITIES: QUANTITIES LISTED IN THE REQUISITION ARE APPROXIMATIONS ONLY, BASED ON ESTIMATES SUPPLIED BY THE STATE SPENDING UNIT. IT IS UNDERSTOOD AND AGREED THAT THE CONTRACT SHALL COVER THE QUANTITIES ACTUALLY ORDERED FOR DELIVERY DURING THE TERM OF THE CONTRACT, WHETHER MORE OR LESS THAN THE QUANTITIES SHOWN.</p> <p>ORDERING PROCEDURE: SPENDING UNIT(S) SHALL ISSUE A WRITTEN STATE CONTRACT ORDER (FORM NUMBER WV-39) TO THE VENDOR FOR COMMODITIES COVERED BY THIS CONTRACT. THE ORIGINAL COPY OF THE WV-39 SHALL BE MAILED TO THE VENDOR AS AUTHORIZATION FOR SHIPMENT, A SECOND COPY MAILED TO THE PURCHASING DIVISION, AND A THIRD COPY RETAINED BY THE SPENDING UNIT.</p>						

SEE REVERSE SIDE FOR TERMS AND CONDITIONS

SIGNATURE	TELEPHONE	DATE
-----------	-----------	------

TITLE	FEIN	ADDRESS CHANGES TO BE NOTED ABOVE
-------	------	-----------------------------------

WHEN RESPONDING TO RFQ, INSERT NAME AND ADDRESS IN SPACE ABOVE LABELED 'VENDOR'



State of West Virginia  
 Department of Administration  
 Purchasing Division  
 2019 Washington Street East  
 Post Office Box 50130  
 Charleston, WV 25305-0130

# Request for Quotation

RFQ NUMBER  
**HSE06074**

PAGE  
**3**

ADDRESS CORRESPONDENCE TO ATTENTION OF:  
**CHUCK BOWMAN**  
**304-558-2157**

VENDOR

\*829083300      540-223-1551  
 RCS COMMUNICATIONS  
 322 LOTS GAP ROAD  
 MAX MEADOWS VA 24360

SHIP TO

HOMELAND SECURITY & EMERGENCY  
 MANAGEMENT, DIVISION OF  
 BUILDING 1, ROOM EB80  
 1900 KANAWHA BOULEVARD, EAST  
 CHARLESTON, WV  
 25305-0360      304-558-5380

DATE PRINTED	TERMS OF SALE	SHIP VIA	F.O.B.	FREIGHT TERMS
07/19/2006				

BID OPENING DATE: **08/16/2006**      BID OPENING TIME **01:30PM**

LINE	QUANTITY	UOP	CAT. NO.	ITEM NUMBER	UNIT PRICE	AMOUNT
<p>BANKRUPTCY: IN THE EVENT THE VENDOR/CONTRACTOR FILES FOR BANKRUPTCY PROTECTION, THIS CONTRACT IS AUTOMATICALLY NULL AND VOID, AND IS TERMINATED WITHOUT FURTHER ORDER.</p> <p>THE TERMS AND CONDITIONS CONTAINED IN THIS CONTRACT SHALL SUPERSEDE ANY AND ALL SUBSEQUENT TERMS AND CONDITIONS WHICH MAY APPEAR ON ANY ATTACHED PRINTED DOCUMENTS SUCH AS PRICE LISTS, ORDER FORMS, SALES AGREEMENTS OR MAINTENANCE AGREEMENTS, INCLUDING ANY ELECTRONIC MEDIUM SUCH AS CD-ROM.</p> <p>REV. 04/11/2001</p> <p>VENDOR PREFERENCE CERTIFICATE</p> <p>CERTIFICATION AND APPLICATION* IS HEREBY MADE FOR PREFERENCE IN ACCORDANCE WITH WEST VIRGINIA CODE, 5A-3-37 (DOES NOT APPLY TO CONSTRUCTION CONTRACTS).</p> <p>A. APPLICATION IS MADE FOR 2.5% PREFERENCE FOR THE REASON CHECKED:</p> <p>( ) BIDDER IS AN INDIVIDUAL RESIDENT VENDOR AND HAS RESIDED CONTINUOUSLY IN WEST VIRGINIA FOR FOUR (4) YEARS IMMEDIATELY PRECEDING THE DATE OF THIS CERTIFICATION; OR</p> <p>( ) BIDDER IS A PARTNERSHIP, ASSOCIATION OR CORPORATION RESIDENT VENDOR AND HAS MAINTAINED ITS HEAD-QUARTERS OR PRINCIPAL PLACE OF BUSINESS CONTINUOUSLY IN WEST VIRGINIA FOR FOUR (4) YEARS IMMEDIATELY PRECEDING THE DATE OF THIS CERTIFICATION; OR 80% OF THE OWNERSHIP INTEREST OF BIDDER IS HELD BY ANOTHER INDIVIDUAL, PARTNERSHIP, ASSOCIATION OR CORPORATION RESIDENT VENDOR</p>						

SEE REVERSE SIDE FOR TERMS AND CONDITIONS

SIGNATURE	TELEPHONE	DATE
TITLE	FEIN	ADDRESS CHANGES TO BE NOTED ABOVE

WHEN RESPONDING TO RFQ, INSERT NAME AND ADDRESS IN SPACE ABOVE LABELED 'VENDOR'



State of West Virginia  
 Department of Administration  
 Purchasing Division  
 2019 Washington Street East  
 Post Office Box 50130  
 Charleston, WV 25305-0130

# Request for Quotation

RFQ NUMBER  
**HSE06074**

PAGE  
**4**

ADDRESS CORRESPONDENCE TO ATTENTION OF  
**CHUCK BOWMAN  
 304-558-2157**

**\*829083300 540-223-1551**  
**RCS COMMUNICATIONS**  
**322 LOTS GAP ROAD**  
  
**MAX MEADOWS VA 24360**

**HOMELAND SECURITY & EMERGENCY  
 MANAGEMENT, DIVISION OF  
 BUILDING 1, ROOM EB80  
 1900 KANAWHA BOULEVARD, EAST  
 CHARLESTON, WV  
 25305-0360 304-558-5380**

DATE PRINTED <b>07/19/2006</b>	TERMS OF SALE	SHIP VIA	F.O.B.	FREIGHT TERMS
-----------------------------------	---------------	----------	--------	---------------

BID OPENING DATE: **08/16/2006** BID OPENING TIME **01:30PM**

LINE	QUANTITY	UOP	CAT. NO.	ITEM NUMBER	UNIT PRICE	AMOUNT
<p>WHO HAS MAINTAINED ITS HEADQUARTERS OR PRINCIPAL PLACE OF BUSINESS CONTINUOUSLY IN WEST VIRGINIA FOR FOUR (4) YEARS IMMEDIATELY PRECEDING THE DATE OF THIS CERTIFICATION; OR</p> <p>( ) BIDDER IS A CORPORATION NONRESIDENT VENDOR WHICH HAS AN AFFILIATE OR SUBSIDIARY WHICH EMPLOYS A MINIMUM OF ONE HUNDRED STATE RESIDENTS AND WHICH HAS MAINTAINED ITS HEADQUARTERS OR PRINCIPAL PLACE OF BUSINESS WITHIN WEST VIRGINIA CONTINUOUSLY FOR THE FOUR (4) YEARS IMMEDIATELY PRECEDING THE DATE OF THIS CERTIFICATION.</p> <p>B. APPLICATION IS MADE FOR 2.5% PREFERENCE FOR THE REASON CHECKED:</p> <p>( ) BIDDER IS A RESIDENT VENDOR WHO CERTIFIES THAT, DURING THE LIFE OF THE CONTRACT, ON AVERAGE AT LEAST 75% OF THE EMPLOYEES WORKING ON THE PROJECT BEING BID ARE RESIDENTS OF WEST VIRGINIA WHO HAVE RESIDED IN THE STATE CONTINUOUSLY FOR THE TWO YEARS IMMEDIATELY PRECEDING SUBMISSION OF THIS BID;</p> <p>OR</p> <p>( ) BIDDER IS A NONRESIDENT VENDOR EMPLOYING A MINIMUM OF ONE HUNDRED STATE RESIDENTS OR IS A NONRESIDENT VENDOR WITH AN AFFILIATE OR SUBSIDIARY WHICH MAINTAINS ITS HEADQUARTERS OR PRINCIPAL PLACE OF BUSINESS WITHIN WEST VIRGINIA EMPLOYING A MINIMUM OF ONE HUNDRED STATE RESIDENTS WHO CERTIFIES THAT, DURING THE LIFE OF THE CONTRACT, ON AVERAGE AT LEAST 75% OF THE EMPLOYEES OR BIDDERS' AFFILIATE'S OR SUBSIDIARY'S EMPLOYEES ARE RESIDENTS OF WEST VIRGINIA WHO HAVE RESIDED IN THE STATE CONTINUOUSLY FOR THE TWO YEARS IMMEDIATELY PRECEDING SUBMISSION OF THIS BID.</p> <p>BIDDER UNDERSTANDS IF THE SECRETARY OF TAX &amp; REVENUE</p>						

SEE REVERSE SIDE FOR TERMS AND CONDITIONS

SIGNATURE	TELEPHONE	DATE
TITLE	FEIN	ADDRESS CHANGES TO BE NOTED ABOVE

WHEN RESPONDING TO RFQ, INSERT NAME AND ADDRESS IN SPACE ABOVE LABELED 'VENDOR'



State of West Virginia  
 Department of Administration  
 Purchasing Division  
 2019 Washington Street East  
 Post Office Box 50130  
 Charleston, WV 25305-0130

# Request for Quotation

RFQ NUMBER  
**HSE06074**

PAGE  
**5**

ADDRESS CORRESPONDENCE TO ATTENTION OF  
**CHUCK BOWMAN**  
**304-558-2157**

VENDOR

\*829083300      540-223-1551  
 RCS COMMUNICATIONS  
 322 LOTS GAP ROAD  
  
 MAX MEADOWS VA 24360

SHIP TO

HOMELAND SECURITY & EMERGENCY  
 MANAGEMENT, DIVISION OF  
 BUILDING 1, ROOM EB80  
 1900 KANAWHA BOULEVARD, EAST  
 CHARLESTON, WV  
 25305-0360      304-558-5380

DATE PRINTED	TERMS OF SALE	SHIP VIA	F.O.B.	FREIGHT TERMS
07/19/2006				

BID OPENING DATE: **08/16/2006**      BID OPENING TIME **01:30PM**

LINE	QUANTITY	UOP	CAT NO	ITEM NUMBER	UNIT PRICE	AMOUNT
<p>DETERMINES THAT A BIDDER RECEIVING PREFERENCE HAS FAILED TO CONTINUE TO MEET THE REQUIREMENTS FOR SUCH PREFERENCE, THE SECRETARY MAY ORDER THE DIRECTOR OF PURCHASING TO: (A) RESCIND THE CONTRACT OR PURCHASE ORDER ISSUED; OR (B) ASSESS A PENALTY AGAINST SUCH BIDDER IN AN AMOUNT NOT TO EXCEED 5% OF THE BID AMOUNT AND THAT SUCH PENALTY WILL BE PAID TO THE CONTRACTING AGENCY OR DEDUCTED FROM ANY UNPAID BALANCE ON THE CONTRACT OR PURCHASE ORDER.</p> <p>BY SUBMISSION OF THIS CERTIFICATE, BIDDER AGREES TO DISCLOSE ANY REASONABLY REQUESTED INFORMATION TO THE PURCHASING DIVISION AND AUTHORIZES THE DEPARTMENT OF TAX AND REVENUE TO DISCLOSE TO THE DIRECTOR OF PURCHASING APPROPRIATE INFORMATION VERIFYING THAT BIDDER HAS PAID THE REQUIRED BUSINESS TAXES, PROVIDED THAT SUCH INFORMATION DOES NOT CONTAIN THE AMOUNTS OF TAXES PAID NOR ANY OTHER INFORMATION DEEMED BY THE TAX COMMISSIONER TO BE CONFIDENTIAL.</p> <p>UNDER PENALTY OF LAW FOR FALSE SWEARING (WEST VIRGINIA CODE 61-5-3), BIDDER HEREBY CERTIFIES THAT THIS CERTIFICATE IS TRUE AND ACCURATE IN ALL RESPECTS; AND THAT IF A CONTRACT IS ISSUED TO BIDDER AND IF ANYTHING CONTAINED WITHIN THIS CERTIFICATE CHANGES DURING THE TERM OF THE CONTRACT, BIDDER WILL NOTIFY THE PURCHASING DIVISION IN WRITING IMMEDIATELY.</p> <p>BIDDER: -----</p> <p>DATE: -----</p> <p>SIGNED: -----</p>						

SEE REVERSE SIDE FOR TERMS AND CONDITIONS

SIGNATURE	TELEPHONE	DATE
TITLE	FEIN	ADDRESS CHANGES TO BE NOTED ABOVE

WHEN RESPONDING TO RFQ, INSERT NAME AND ADDRESS IN SPACE ABOVE LABELED 'VENDOR'



State of West Virginia  
Department of Administration  
Purchasing Division  
2019 Washington Street East  
Post Office Box 50130  
Charleston, WV 25305-0130

# Request for Quotation

RFQ NUMBER  
**HSE06074**

PAGE  
**6**

ADDRESS CORRESPONDENCE TO ATTENTION OF  
**CHUCK BOWMAN  
304-558-2157**

**VENDOR**

\*829083300 540-223-1551  
RCS COMMUNICATIONS  
322 LOTS GAP ROAD  
MAX MEADOWS VA 24360

**SHIP TO**

HOMELAND SECURITY & EMERGENCY  
MANAGEMENT, DIVISION OF  
BUILDING 1, ROOM EB80  
1900 KANAWHA BOULEVARD, EAST  
CHARLESTON, WV  
25305-0360 304-558-5380

DATE PRINTED	TERMS OF SALE	SHIP VIA	F.O.B.	FREIGHT TERMS
07/19/2006				

BID OPENING DATE: **08/16/2006** BID OPENING TIME **01:30PM**

LINE	QUANTITY	UOP	CAT NO	ITEM NUMBER	UNIT PRICE	AMOUNT
TITLE: -----						
* CHECK ANY COMBINATION OF PREFERENCE CONSIDERATION(S) IN EITHER "A" OR "B", OR BOTH "A" AND "B" WHICH YOU AR ENTITLED TO RECEIVE. YOU MAY REQUEST UP TO THE MAXIMUM 5% PREFERENCE FOR BOTH "A" AND "B". (REV. 12/00)						
NOTICE						
A SIGNED BID MUST BE SUBMITTED TO:  DEPARTMENT OF ADMINISTRATION PURCHASING DIVISION BUILDING 15 2019 WASHINGTON STREET, EAST CHARLESTON, WV 25305-0130						
THE BID SHOULD CONTAIN THIS INFORMATION ON THE FACE OF THE ENVELOPE OR THE BID MAY NOT BE CONSIDERED:						
SEALED BID						
BUYER:				CB-23		
RFQ. NO.:				HSE06074		
BID OPENING DATE:				08/16/2006		

SEE REVERSE SIDE FOR TERMS AND CONDITIONS

SIGNATURE \_\_\_\_\_ TELEPHONE \_\_\_\_\_ DATE \_\_\_\_\_

TITLE \_\_\_\_\_ FEIN \_\_\_\_\_ ADDRESS CHANGES TO BE NOTED ABOVE

WHEN RESPONDING TO RFQ, INSERT NAME AND ADDRESS IN SPACE ABOVE LABELED 'VENDOR'





State of West Virginia  
 Department of Administration  
 Purchasing Division  
 2019 Washington Street East  
 Post Office Box 50130  
 Charleston, WV 25305-0130

# Request for Quotation

RFQ NUMBER  
**HSE06074**

PAGE  
**7**

ADDRESS CORRESPONDENCE TO ATTENTION OF:  
**CHUCK BOWMAN**  
**304-558-2157**

VENDOR

\*829083300      540-223-1551  
 RCS COMMUNICATIONS  
 322 LOTS GAP ROAD  
 MAX MEADOWS VA 24360

SHIP TO

HOMELAND SECURITY & EMERGENCY  
 MANAGEMENT, DIVISION OF  
 BUILDING 1, ROOM EB80  
 1900 KANAWHA BOULEVARD, EAST  
 CHARLESTON, WV  
 25305-0360      304-558-5380

DATE PRINTED	TERMS OF SALE	SHIP VIA	F.O.B.	FREIGHT TERMS
07/19/2006				

BID OPENING DATE: **08/16/2006**      BID OPENING TIME **01:30PM**

LINE	QUANTITY	UOP	CAT NO.	ITEM NUMBER	UNIT PRICE	AMOUNT
BID OPENING TIME:				1:30 PM		
PLEASE PROVIDE A FAX NUMBER IN CASE IT IS NECESSARY TO CONTACT YOU REGARDING YOUR BID:						
-----						
CONTACT PERSON (PLEASE PRINT CLEARLY):						
-----						
***** THIS IS THE END OF RFQ HSE06074 ***** TOTAL:						_____

SEE REVERSE SIDE FOR TERMS AND CONDITIONS

SIGNATURE		TELEPHONE	DATE
TITLE	FEIN	ADDRESS CHANGES TO BE NOTED ABOVE	

WHEN RESPONDING TO RFQ, INSERT NAME AND ADDRESS IN SPACE ABOVE LABELED 'VENDOR'

## TECHNCIAL SERVICES CONTRACT

### GENERAL:

The West Virginia Division of Homeland Security and Emergency Management operates the State Flood Warning System consisting of radio reporting rain and stream gages located in all 55 counties. There are 310 data gathering sites supporting approximately 900 sensors. This rain and stream gage data is relayed to the agency's office near Charleston, West Virginia using 35 radio repeater sites. Additionally, using funding provided by the U.S. Division of Homeland Security, the agency is in the process of installing 110 High Sierra complete weather stations. All of this data is then placed on the Internet at [www.rainfall.net](http://www.rainfall.net). Additionally, we feed this data to the National Oceanic and Atmospheric Administration's gateway for use by the National Weather Service. Use of this data by the National Weather Service allows them to more accurately issue flood watches and warnings thus saving lives and reducing property damage.

### PURPOSE OF CONTRACT:

The purpose of this contract is to provide technical support in the maintenance, repair and expansion of the State Flood Warning System.

Vendor must be recognized in the ALERT/ flood warning industry with a technical background of at least two years. Vendors, at any time requested, must satisfy the State that they have the requisite organization, capital and experience to provide the required technical support. The State reserves the right to make such investigations as deemed necessary to determine the ability of a vendor to perform. The vendor shall furnish to the State such information as may reasonably be requested, including but not limited to, a list of the service equipment available to the vendor. By submitting a bid, the vendor certifies that he/she fully understands all of the system requirements as described herein; that he/she is fully informed as to the nature, scope and location of work to be performed. Extensive travel by the vendor will be required to rugged and remote areas of the State often requiring the use of four-wheel drive vehicles. Working outdoors in inclement weather will be required.

Vendor must have the technical expertise to program, diagnose and perform component level repair of meteorological and analog data communications equipment manufactured by the following companies or manufacturers of similar types of equipment that the State of West Virginia may purchase during the life of this contract.

Daniels Electronics LTD.  
43 Erie Street  
Victoria, B.C.  
Canada V8V 1P8

Design Analysis  
Water Log Division  
75 West 100 South  
Logan, Utah 84321

High Sierra Electronics  
13355 Grass Valley Avenue  
Grass Valley, CA 95945

RFL Electronics, Inc.  
353 Powerville Road  
Boonton Township, NJ 07005

Vaisala Inc.  
Handar Business Unit  
1288 Reamwood Avenue  
Sunnyvale, CA 94089

Vendor should provide professional certification of expertise via licensing, training certificates, etc., for all personnel qualified to perform the work as described in this advertisement for contract. The agency reserves the right to request this or additional information at any time during the evaluation process prior to the recommendation of award. Vendor failure to submit this requested information to the agency in a timely manner may result in the disqualification of said vendor's bid proposal.

Vendor must supply proof of Public Liability Insurance in the amount of \$250,000.00 prior to the issuance of the purchase order to the agency recommended vendor.

Vendor is responsible for providing all parts and test equipment to perform the scope of work in this advertisement for contract. All parts are to be bid cost + percentage mark-up. Vendor invoices including parts must be accompanied by a paid receipt for the parts in order to be considered for reimbursement.

Vendor is responsible for bench work items and for picking them up at the agency location in Big Chimney. Physical address for this location is:  
WV Division of Homeland Security & Emergency Management  
4750 Chimney Drive  
Charleston, WV 25302

All repairs shall be completed within thirty (30) days from the time the equipment/parts are delivered to the vendor's repair facility. The agency reserves the right to request verification of date of delivery for all parts. All bench work labor of the vendor shall be warranted for a minimum of one (1) year after agency acceptance of the work. Standard parts warranties will be accepted as established by the manufacturer.

Vendor's quoted hourly rate for maintenance and repair work performed in the field MUST be inclusive of all costs including mileage and all other travel expenses. The State will not separately reimburse vendors for mileage and travel expenses. A separate hourly rate will be quoted for bench work performed in the vendor's shop facility.

# BID FORM

010

Project Request for Quotation: # HSE06074

Date: August 16, 2006

Agency: West Virginia Division of Homeland Security and Emergency Management

The undersigned, hereafter called the Bidder, being familiar with and understanding the Bidding documents; having examined scope affecting the Project, hereby proposes to furnish labor, material, equipment, supplies, and transportation to perform the Work as follows:

HOURLY LABOR RATE: (Field Work Including Travel, etc.) \_\_\_\_\_ \$ 56 / Hour

HOURLY LABOR RATE: (Bench Work performed in Shop) \_\_\_\_\_ \$ 42 / Hour

PARTS: ( Cost + % markup) \_\_\_\_\_ 10 % 10% Mark Up

**Bid Schedule Scenario for Bid Evaluation Purposes ONLY. Quantities are for evaluation purposes and do not reflect estimated quantities expected for the life of this contract. Unit prices prevail.**

<u>BID ITEM</u>	<u>QTY</u>	<u>UNIT PRICE</u>	<u>EXTENDED PRICE</u>
1. Field Work	(3)	\$ <u>56</u> /hr	= \$ <u>168<sup>00</sup></u>
2. Bench Work	(6)	\$ <u>42</u> /hr	= \$ <u>252<sup>00</sup></u>
3. Data Transmitter #HSE 3206-08 & Repeater #HSE 3300 REPLACEMENT PART: MAXON DATA RADIO MODEL# SD-125V2	(1)	\$ <u>189<sup>00</sup></u> ea + <u>10</u> %	= \$ <u>207<sup>90</sup></u>
4. MOST RAIN & STREAM GAUGES (Currently installed in WV) REPLACEMENT PART: MAXROD ANTENNA COIL MODEL# SD-125VMHB5800 (or equal)	(1)	\$ <u>34<sup>00</sup></u> ea + <u>10</u> %	= \$ <u>38<sup>00</sup></u>
5. MOST RAIN GAUGES (Currently installed in WV) REPLACEMENT PART: NATIONAL SOLAR, 1 watt Solar Panel MODEL# BSP-112 (or equal)	(1)	\$ <u>19<sup>98</sup></u> ea + <u>10</u> %	= \$ <u>21<sup>98</sup></u>
		<b>TOTAL</b>	\$ <u>687<sup>94</sup></u>

VENDOR NAME: RES COMMUNICATIONS  
SIGNATURE : [Signature]  
DATE : 08/11/2006

**A F F I D A V I T**011**West Virginia Code §5A-3-10a states:**

No contract or renewal of any contract may be awarded by the state or any of its political subdivisions to any vendor or prospective vendor when the vendor or prospective vendor or a related party to the vendor or prospective vendor is a debtor and the debt owned is an amount greater than one thousand dollars in the aggregate.

**DEFINITIONS:**

"Debt" means any assessment, premium, penalty, fine, tax or other amount of money owed to the state or any of its political subdivisions because of a judgment, fine, permit violation, license assessment, defaulted workers' compensation premium, penalty or other assessment presently delinquent or due and required to be paid to the state or any of its political subdivisions, including any interest or additional penalties accrued thereon.

"Debtor" means any individual, corporation, partnership, association, limited liability company or any other form or business association owing a debt to the state or any of its political subdivisions.

"Political subdivision" means any county commission; municipality; county board of education; any instrumentality established by a county or municipality; any separate corporation or instrumentality established by one or more counties or municipalities, as permitted by law; or any public body charged by law with the performance of a government function or whose jurisdiction is coextensive with one or more counties or municipalities.

"Related party" means a party, whether an individual, corporation, partnership, association, limited liability company or any other form or business association or other entity whatsoever, related to any vendor by blood, marriage, ownership or contract through which the party has a relationship of ownership or other interest with the vendor so that the party will actually or by effect receive or control a portion of the benefit, profit or other consideration from performance of a vendor contract with the party receiving an amount that meets or exceeds five percent of the total contract amount.

**EXCEPTION:**

The prohibition of this section does not apply where a vendor has contested any tax administered pursuant to chapter eleven of this code, workers' compensation premium, permit fee or environmental fee or assessment and the matter has not become final or where the vendor has entered into a payment plan or agreement and the vendor is not in default of any of the provisions of such plan or agreement.

**LICENSING:**

The vendor must be licensed in accordance with any and all state requirements to do business with the state of West Virginia.

**CONFIDENTIALITY:**

The vendor agrees that he or she will not disclose to anyone, directly or indirectly, any such personally identifiable information or other confidential information gained from the agency, unless the individual who is the subject of the information consents to the disclosure in writing or the disclosure is made pursuant to the agency's policies, procedures and rules. Vendors should visit [www.state.wv.us/admin/purchase/privacy](http://www.state.wv.us/admin/purchase/privacy) for the Notice of Agency Confidentiality Policies.

Under penalty of law for false swearing (West Virginia Code, §61-5-3), it is hereby certified that the vendor acknowledges the information in this said affidavit and are in compliance with the requirements as stated.

Vendor's Name: RES COMMUNICATIONS

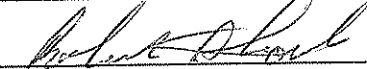
Authorized Signature:  Date: 08/11/2006