



State of West Virginia
 Department of Administration
 Purchasing Division
 2019 Washington Street East
 Post Office Box 50130
 Charleston, WV 25305-0130

Request for Quotation

RFQ NUMBER
DEP13568

PAGE
1

ADDRESS CORRESPONDENCE TO ATTENTION OF:
CHUCK BOWMAN 304-558-2157

RFQ COPY
 TYPE NAME/ADDRESS HERE

VENDOR

Triple H. Construction
PO Box 176
Beverly, WV 26253

SHIP TO

ENVIRONMENTAL PROTECTION
 DEPT. OF
 OFFICE OF SPECIAL RECLAMATION
 105 S. RAILROAD STREET
 PHILIPPI, WV
 26416-9998 304-457-3219

DATE PRINTED	TERMS OF SALE	SHIP VIA	F.O.B.	FREIGHT TERMS
08/16/2006				

BID OPENING DATE: 10/03/2006 BID OPENING TIME 01:30PM

LINE	QUANTITY	UOP	CAT. NO.	ITEM NUMBER	UNIT PRICE	AMOUNT
0001	1	JB		962-73		\$ 450,000. ⁰⁰
<p>RECLAMATION: RESTORATION OF WATER</p> <p>THE WEST VIRGINIA PURCHASING DIVISION, ON BEHALF OF THE AGENCY, THE WEST VIRGINIA DEPARTMENT OF ENVIRONMENTAL PROTECTION'S OFFICE OF SPECIAL RECLAMATION, IS SEEKING BIDS FOR A THE FOLLOWING CONSTRUCTION CONTRACT. THE PURPOSE OF THE CONTRACT IS TO PERFORM WATER RECLAMATION ON THE MINING OPERATION OF DAUGHERTY COAL COMPANY, INC., NOW UNDER REVOKED PERMIT 65-77, PER THE FOLLOWING SPECIFICATIONS, BID REQUIREMENTS, TERMS & CONDITIONS AND THE ATTACHED SPECIFICATIONS.</p> <p>THE RECLAMATION SHALL BE PERFORMED UNDER THE GUIDANCE AND GENERAL SUPERVISION OF THE AGENT ASSIGNED TO THE PROJECT FOR THE STATE OF WEST VIRGINIA, DEPARTMENT OF ENVIRONMENTAL PROTECTION.</p> <p>A MANDATORY ON SITE PREBID CONFERENCE SHALL BE HELD ON 09/06/06 @ 10:00 AM. FAILURE TO ATTEND THE PREBID CONFERENCE WILL RESULT IN BID DISQUALIFICATION.</p> <p>THE CONTRACTOR SHALL PROVIDE ALL LABOR, MATERIALS, EQUIPMENT AND OTHER NECESSARY SERVICES SO AS TO ACCOMPLISH THE ITEMS AS SPECIFIED IN THIS CONTRACT. PROJECT IS LOCATED NEAR MASONTOWN, WV (PRESTON COUNTY) AND CONSISTS OF APPROXIMATELY 4 ACRES.</p> <p>PROJECT CONTACT PERSON: JIM SECKMAN</p>						

SEE REVERSE SIDE FOR TERMS AND CONDITIONS

SIGNATURE <i>Arnold B. Harper</i>	TELEPHONE 304-636-1194	DATE 9-30-2006
TITLE Owner	FEIN 55-0482970	ADDRESS CHANGES TO BE NOTED ABOVE

WHEN RESPONDING TO RFQ, INSERT NAME AND ADDRESS IN SPACE ABOVE LABELED 'VENDOR'

**GENERAL TERMS & CONDITIONS
REQUEST FOR QUOTATION (RFQ) AND REQUEST FOR PROPOSAL (RFP)**

1. Awards will be made in the best interest of the State of West Virginia.
2. The State may accept or reject in part, or in whole, any bid.
3. All quotations are governed by the *West Virginia Code* and the *Legislative Rules* of the Purchasing Division.
4. Prior to any award, the apparent successful vendor must be properly registered with the Purchasing Division and have paid the required \$125.00 registration fee.
5. All services performed or goods delivered under State Purchase Orders/Contracts are to be continued for the term of the Purchase Order/Contract, contingent upon funds being appropriated by the Legislature or otherwise being made available. In the event funds are not appropriated or otherwise available for these services or goods, this Purchase Order/Contract becomes void and of no effect after June 30.
6. Payment may only be made after the delivery and acceptance of goods or services.
7. Interest may be paid for late payment in accordance with the *West Virginia Code*.
8. Vendor preference will be granted upon written request in accordance with the *West Virginia Code*.
9. The State of West Virginia is exempt from federal and state taxes and will not pay or reimburse such taxes.
10. The Director of Purchasing may cancel any Purchase Order/Contract upon 30 days written notice to the seller.
11. The laws of the State of West Virginia and the *Legislative Rules* of the Purchasing Division shall govern all rights and duties under the Contract, including without limitation the validity of this Purchase Order/Contract.
12. Any reference to automatic renewal is hereby deleted. The Contract may be renewed only upon mutual written agreement of the parties.
13. **BANKRUPTCY:** In the event the vendor/contractor files for bankruptcy protection, this contract is automatically null and void, and is terminated without further order.
14. **HIPAA Business Associate Addendum -** The West Virginia State Government HIPAA Business Associate Addendum (BAA), approved by the Attorney General, and available online at the Purchasing Division's web site (<http://www.state.wv.us/admin/purchase/vrc/hipaa.htm>) is hereby made part of the agreement. Provided that, the Agency meets the definition of a Covered Entity (45 CFR §160.103) and will be disclosing Protected Health Information (45 CFR §160.103) to the vendor.

INSTRUCTIONS TO BIDDERS

1. Use the quotation forms provided by the Purchasing Division.
2. **SPECIFICATIONS:** Items offered must be in compliance with the specifications. Any deviation from the specifications must be clearly indicated by the bidder. Alternates offered by the bidder as **EQUAL** to the specifications must be clearly defined. A bidder offering an alternate should attach complete specifications and literature to the bid. The Purchasing Division may waive minor deviations to specifications.
3. Complete all sections of the quotation form.
4. Unit prices shall prevail in cases of discrepancy.
5. All quotations are considered F.O.B. destination unless alternate shipping terms are clearly identified in the quotation.
6. **BID SUBMISSION:** All quotations must be delivered by the bidder to the office listed below prior to the date and time of the bid opening. Failure of the bidder to deliver the quotations on time will result in bid disqualifications.

SIGNED BID TO:

Department of Administration
Purchasing Division
2019 Washington Street East
Post Office Box 50130
Charleston, WV 25305-0130



State of West Virginia
 Department of Administration
 Purchasing Division
 2019 Washington Street East
 Post Office Box 50130
 Charleston, WV 25305-0130

Request for Quotation

RFQ NUMBER
DEP13568

PAGE
2

ADDRESS CORRESPONDENCE TO ATTENTION OF
CHUCK BOWMAN
304-558-2157

RFQ COPY
 TYPE NAME/ADDRESS HERE

VENDOR

SHIP TO

ENVIRONMENTAL PROTECTION
 DEPT. OF
 OFFICE OF SPECIAL RECLAMATION
 105 S. RAILROAD STREET
 PHILIPPI, WV
 26416-9998 304-457-3219

DATE PRINTED 08/16/2006	TERMS OF SALE	SHIP VIA	F.O.B.	FREIGHT TERMS
-----------------------------------	---------------	----------	--------	---------------

BID OPENING DATE: **10/03/2006** BID OPENING TIME: **01:30PM**

LINE	QUANTITY	UOP	CAT. NO.	ITEM NUMBER	UNIT PRICE	AMOUNT
				DEPT. OF ENVIRONMENTAL PROTECTION 105 SOUTH RAILROAD STREET, SUITE 301 PHILIPPI, WV 26416 (304) 457-3219 ALL WORK MUST BE COMPLETED IN ACCORDANCE WITH THE PLANS AND SPECIFICATIONS PREPARED BY THE DEPARTMENT OF ENVIRONMENTAL PROTECTION AND PURCHASE ORDER ISSUED BY THE DEPARTMENT OF ADMINISTRATION, PURCHASING DIVISION. PREFERENCE FOR USE OF DOMESTIC STEEL PRODUCTS 1. EXCEPT WHEN AUTHORIZED BY THE DIRECTOR OF THE PURCHASING DIVISION PURSUANT TO SUBSECTION 2 BELOW, NO CONTRACTOR MAY USE OR SUPPLY STEEL PRODUCTS FOR A STATE CONTRACT PROJECT OTHER THAN THOSE STEEL PRODUCTS MADE IN THE UNITED STATES. AS USED IN THIS CONTRACT, A. "STATE CONTRACT PROJECT" MEANS ANY ERECTION OR CONSTRUCTION OF, OR ANY ADDITION TO, ALTERATION OF OR OTHER IMPROVEMENT TO ANY BUILDING OR STRUCTURE, INCLUDING, BUT NOT LIMITED TO, ROADS OR HIGHWAYS, OR THE INSTALLATION OF ANY HEATING OR COOLING OR VENTILATING PLANTS OR OTHER EQUIPMENT, OR THE SUPPLY OF AND MATERIALS FOR SUCH PROJECTS, PURSUANT TO A CONTRACT WITH THE STATE OF WEST VIRGINIA FOR WHICH BIDS WERE SOLICITED ON OR AFTER JUNE 6, 2001. B. "STEEL PRODUCTS" MEANS PRODUCTS ROLLED, FORMED SHAPED, DRAWN, EXTRUDED, FORGED, CAST, FABRICATED OR OTHERWISE SIMILARLY PROCESSED, OR PROCESSED BY A COMBINATION OF TWO OR MORE OF SUCH OPERATIONS, FROM STEEL MADE BY THE OPEN HEARTH, BASIC OXYGEN, ELECTRIC FURNACE, BESSEMER OR OTHER STEEL MAKING PROCESS.		

SEE REVERSE SIDE FOR TERMS AND CONDITIONS

SIGNATURE <i>Howard H. Hansen</i>	TELEPHONE 304-636-1194	DATE 9-30-2006
TITLE Owner	FAX 55-0482970	ADDRESS CHANGES TO BE NOTED ABOVE

WHEN RESPONDING TO RFQ, INSERT NAME AND ADDRESS IN SPACE ABOVE LABELED 'VENDOR'



State of West Virginia
 Department of Administration
 Purchasing Division
 2019 Washington Street East
 Post Office Box 50130
 Charleston, WV 25305-0130

Request for Quotation

RFO NUMBER
 DEP13568

PAGE
 4

ADDRESS CORRESPONDENCE TO ATTENTION OF:
 CHUCK BOWMAN
 304-558-2157

RFQ COPY
 TYPE NAME/ADDRESS HERE

VENDOR

SHIP TO

ENVIRONMENTAL PROTECTION
 DEPT. OF
 OFFICE OF SPECIAL RECLAMATION
 105 S. RAILROAD STREET
 PHILIPPI, WV
 26416-9998 304-457-3219

DATE PRINTED 08/16/2006	TERMS OF SALE	SHIP VIA	F.O.B.	FREIGHT TERMS
----------------------------	---------------	----------	--------	---------------

BID OPENING DATE: 10/03/2006 BID OPENING TIME 01:30PM

LINE	QUANTITY	UOP	CAT. NO.	ITEM NUMBER	UNIT PRICE	AMOUNT
<p>CANCELLATION: THE DIRECTOR OF PURCHASING RESERVES THE RIGHT TO CANCEL THIS CONTRACT IMMEDIATELY UPON WRITTEN NOTICE TO THE VENDOR IF THE MATERIALS OR WORKMANSHIP SUPPLIED ARE OF AN INFERIOR QUALITY OR DO NOT CONFORM WITH THE SPECIFICATIONS OF THE BID AND CONTRACT HERE IN.</p> <p>WAGE RATES: THE CONTRACTOR OR SUBCONTRACTOR SHALL PAY THE HIGHER OF THE U.S. DEPARTMENT OF LABOR MINIMUM WAG RATES AS ESTABLISHED FOR PRESTON COUNTY, PURSUANT TO WEST VIRGINIA CODE 21-5-1, ET, SEQ.</p> <p>ARBITRATION: ANY REFERENCES MADE TO ARBITRATION OR INTEREST FOR PAYMENTS DUE (EXCEPT FOR ANY INTEREST REQUIRED BY STATE LAW) CONTAINED IN THIS CONTRACT OR IN ANY AMERICAN INSTITUTE OF ARCHITECTS DOCUMENTS PERTAINING TO THIS CONTRACT ARE HEREBY DELETED.</p> <p>WORKERS' COMPENSATION: VENDOR IS REQUIRED TO PROVIDE A CERTIFICATE FROM WORKERS' COMPENSATION IF SUCCESSFUL.</p> <p>ALL OF THE ITEMS CHECKED BELOW WILL BE A REQUIREMENT OF THIS CONTRACT:</p> <p>(XX) INSURANCE: SUCCESSFUL VENDOR SHALL FURNISH PROOF OF COMMERCIAL GENERAL LIABILITY INSURANCE PRIOR TO ISSUANCE OF CONTRACT. UNLESS OTHERWISE SPECIFIED IN THE BID DOCUMENTS, THE MINIMUM AMOUNT OF INSURANCE COVERAGE REQUIRED IS \$250,000.</p> <p>() BUILDERS RISK INSURANCE: SUCCESSFUL VENDOR SHALL FURNISH PROOF OF BUILDERS RISK - ALL RISK INSURANCE IN AN AMOUNT EQUAL TO 100% OF THE AMOUNT OF THE CONTRACT.</p>						

SEE REVERSE SIDE FOR TERMS AND CONDITIONS

SIGNATURE <i>Howard N. Harper</i>	TELEPHONE 304-636-1194	DATE 9-30-2006
TITLE Owner	FEIN 55-0482970	ADDRESS CHANGES TO BE NOTED ABOVE

WHEN RESPONDING TO RFQ, INSERT NAME AND ADDRESS IN SPACE ABOVE LABELED 'VENDOR'



State of West Virginia
 Department of Administration
 Purchasing Division
 2019 Washington Street East
 Post Office Box 50130
 Charleston, WV 25305-0130

Request for Quotation

RFQ NUMBER
 DEP13568

PAGE
 5

ADDRESS CORRESPONDENCE TO ATTENTION OF
 CHUCK BOWMAN
 304-558-2157

RFQ COPY
 TYPE NAME/ADDRESS HERE

VENDOR

SHIP TO

ENVIRONMENTAL PROTECTION
 DEPT. OF
 OFFICE OF SPECIAL RECLAMATION
 105 S. RAILROAD STREET
 PHILIPPI, WV
 26416-9998 304-457-3219

DATE PRINTED 08/16/2006	TERMS OF SALE	SHIP VIA	F.O.B.	FREIGHT TERMS
----------------------------	---------------	----------	--------	---------------

BID OPENING DATE: 10/03/2006 BID OPENING TIME 01:30PM

LINE	QUANTITY	UOP	CAT. NO.	ITEM NUMBER	UNIT PRICE	AMOUNT
	<p>(XX) BONDS: FIVE PERCENT (5%) OF THE TOTAL AMOUNT OF THE BID PAYABLE TO THE STATE OF WEST VIRGINIA, SHALL BE SUBMITTED WITH EACH BID AS A BID BOND. THE SUCCESSFUL BIDDER SHALL ALSO FURNISH A PERFORMANCE BOND AND LABOR/MATERIAL BOND FOR 100% OF THE AMOUNT OF THE CONTRACT. BONDS MAY BE PROVIDED IN THE FORM OF A CERTIFIED CHECK, IRREVOCABLE LETTER OF CREDIT, OR BOND FURNISHED BY A SOLVENT SURETY COMPANY AUTHORIZED TO DO BUSINESS IN THE STATE OF WEST VIRGINIA. A LETTER OF CREDIT SUBMITTED IN LIEU OF A PERFORMANCE AND LABOR & MATERIAL BOND WILL ONLY BE ALLOWED FOR PROJECTS UNDER \$100,000. PERSONAL OR BUSINESS CHECKS ARE NOT ACCEPCTABLE IN LIEU OF THE 5% BID BOND, PERFORMANCE BOND, OR LABOR AND MATERIAL BOND.</p> <p>() MAINTENANCE BOND: A TWO (2) YEAR MAINTENANCE BOND COVERING THE ROOFING SYSTEM WILL BE A REQUIREMENT OF THE SUCCESSFUL VENDOR.</p> <p>REV. 3/91</p> <p>EXHIBIT 7</p> <p>DOMESTIC ALUMINUM, GLASS & STEEL IN PUBLIC WORKS PROJECTS</p> <p>IN ACCORDANCE WITH WEST VIRGINIA CODE 5-19-1 ET., SEQ., EVERY CONTRACT FOR CONSTRUCTION, RECONSTRUCTION, ALTERATION, REPAIR, IMPROVEMENT OR MAINTENANCE OF PUBLIC WORKS, WHERE THE COST IS MORE THAN \$50,000 AND, IN THE CASE OF STEEL ONLY, WHERE THE COST OF STEEL IS MORE THAN \$50,000 OR WHERE MORE THAN 10,000 POUNDS OF STEEL ARE REQUIRED, THE STATE WILL ACCEPT ONLY ALUMINUM GLASS, OR STEEL PRODUCTS PRODUCED IN THE UNITED STATES</p>					

SEE REVERSE SIDE FOR TERMS AND CONDITIONS

NATURE <i>Howard H Harper</i>	TELEPHONE <i>304-636-1194</i>	DATE <i>9-30-2006</i>
OWNER <i>Owner</i>	FEIN <i>55-0482970</i>	ADDRESS CHANGES TO BE NOTED ABOVE

WHEN RESPONDING TO RFQ, INSERT NAME AND ADDRESS IN SPACE ABOVE LABELED 'VENDOR'



State of West Virginia
 Department of Administration
 Purchasing Division
 2019 Washington Street East
 Post Office Box 50130
 Charleston, WV 25305-0130

Request for Quotation

RFQ NUMBER
 DEP13568

PAGE
 6

ADDRESS CORRESPONDENCE TO ATTENTION OF:
 CHUCK BOWMAN
 304-558-2157

RFQ COPY
 TYPE NAME/ADDRESS HERE

VENDOR

SHIP TO

ENVIRONMENTAL PROTECTION
 DEPT. OF
 OFFICE OF SPECIAL RECLAMATION
 105 S. RAILROAD STREET
 PHILIPPI, WV
 26416-9998 304-457-3219

DATE PRINTED 08/16/2006	TERMS OF SALE	SHIP VIA	F.O.B.	FREIGHT TERMS
----------------------------	---------------	----------	--------	---------------

BID OPENING DATE: 10/03/2006 BID OPENING TIME 01:30PM

LINE	QUANTITY	UOP	CAT. NO.	ITEM NUMBER	UNIT PRICE	AMOUNT
<p>IN ADDITION, ITEMS OF MACHINERY OR EQUIPMENT PURCHASED FOR USE AT THE SITE OF PUBLIC WORKS SHALL BE MADE OF DOMESTIC ALUMINUM, GLASS OR STEEL, UNLESS THE COST OF THE PRODUCT IS LESS THAN \$50,000 OR LESS THAN 10,000 POUNDS OF STEEL ARE USED IN PUBLIC WORKS PROJECTS.</p> <p>FOREIGN MADE ALUMINUM, GLASS OR STEEL PRODUCTS MAY BE ACCEPTED ONLY IF THE COST OF DOMESTIC PRODUCTS IS FOUND TO BE UNREASONABLE. SUCH COST IS UNREASONABLE IF IT IS 20% OR MORE HIGHER THAN THE BID PRICE FOR FOREIGN MADE PRODUCTS. IF THE DOMESTIC ALUMINUM, GLASS OR STEEL PRODUCTS TO BE SUPPLIED OR PRODUCED IN A "SUBSTANTIAL LABOR SURPLUS AREA", AS DEFINED BY THE UNITED STATES DEPARTMENT OF LABOR, FOREIGN PRODUCTS MAY BE SUPPLIED ONLY IF DOMESTIC PRODUCTS ARE 30% OR MORE HIGHER IN PRICE THAN THE FOREIGN MADE PRODUCTS.</p> <p>IF, PRIOR TO THE AWARD OF A CONTRACT UNDER THE ABOVE PROVISIONS, THE SPENDING OFFICER OF THE SPENDING UNIT DETERMINES THAT THERE EXISTS A BID FOR LIKE FOREIGN ALUMINUM, GLASS OR STEEL THAT IS REASONABLE AND LOWER THAN THE LOWEST BID DOMESTIC PRODUCTS, THE SPENDING OFFICE MAY REQUEST, IN WRITING, A REEVALUATION AND REDUCTION IN THE LOWEST BID FOR SUCH DOMESTIC PRODUCTS ALL VENDORS MUST INDICATE IN THEIR BID IF THEY ARE SUPPLYING FOREIGN ALUMINUM, GLASS OR STEEL.</p> <p>REV. 3/88</p> <p>EXHIBIT 9</p> <p>NOTICE FOR ISSUANCE & ACKNOWLEDGEMENT OF CONSTRUCTION PROJECT ADDENDA</p> <p>THE ARCHITECT/ENGINEER AND/OR AGENCY SHALL BE REQUIRED TO ABIDE BY THE FOLLOWING SCHEDULE IN ISSUING</p>						

SEE REVERSE SIDE FOR TERMS AND CONDITIONS

SIGNATURE <i>Edward A. Harger</i>	TELEPHONE 304-636-7194	DATE 9-30-2006
TITLE Owner	FAX 55-048 2970	ADDRESS CHANGES TO BE NOTED ABOVE

WHEN RESPONDING TO RFQ, INSERT NAME AND ADDRESS IN SPACE ABOVE LABELED 'VENDOR'



State of West Virginia
 Department of Administration
 Purchasing Division
 2019 Washington Street East
 Post Office Box 50130
 Charleston, WV 25305-0130

Request for Quotation

RFQ NUMBER
DEP13568

PAGE
7

ADDRESS CORRESPONDENCE TO ATTENTION OF:
CHUCK BOWMAN 304-558-2157

RFQ COPY
TYPE NAME/ADDRESS HERE
VENDOR

SHIP TO
ENVIRONMENTAL PROTECTION DEPT. OF OFFICE OF SPECIAL RECLAMATION 105 S. RAILROAD STREET PHILIPPI, WV 26416-9998 304-457-3219

DATE PRINTED	TERMS OF SALE	SHIP VIA	F.O.B.	FREIGHT TERMS
08/16/2006				

BID OPENING DATE: 10/03/2006 BID OPENING TIME 01:30PM

LINE	QUANTITY	UOP	CAT. NO.	ITEM NUMBER	UNIT PRICE	AMOUNT
<p>CONSTRUCTION PROJECT ADDENDA FOR STATE AGENCIES:</p> <p>(1) THE ARCHITECT/ENGINEER SHALL PREPARE THE ADDENDUM AND A LIST OF ALL PARTIES THAT HAVE PROCURED DRAWINGS AND SPECIFICATIONS FOR THE PROJECT. THE ADDENDUM AND LIST SHALL BE FORWARDED TO THE BUYER IN THE STATE PURCHASING DIVISION. THE ARCHITECT/ENGINEER SHALL ALSO SEND A COPY OF THE ADDENDUM TO THE STATE AGENCY FOR WHICH THE CONTRACT IS ISSUED.</p> <p>(2) THE BUYER SHALL SEND THE ADDENDUM TO ALL INTERESTED PARTIES AND, IF NECESSARY, EXTEND THE BID OPENING DATE. ANY ADDENDUM SHOULD BE RECEIVED BY THE BUYER WITHIN FOURTEEN (14) DAYS PRIOR TO THE BID OPENING DATE.</p> <p>CIRCUMSTANCES.</p> <p>(3) ALL ADDENDA SHOULD BE FORMALLY ACKNOWLEDGED BY ALL BIDDERS AND SUBMITTED TO THE STATE PURCHASING DIVISION AND THE STATE AUDITOR'S OFFICE. THE SAME RULES AND REGULATIONS THAT APPLY TO THE ORIGINAL BIDDING DOCUMENT SHALL ALSO APPLY TO AN ADDENDUM DOCUMENT. THE ONLY EXCEPTION MAY BE FOR AN ADDENDUM THAT IS ISSUED FOR THE SOLE PURPOSE OF CHANGING A BID OPENING TIME AND/OR DATE.</p> <p>REV. 11/96</p> <p>EXHIBIT 10</p> <p>ADDENDUM ACKNOWLEDGEMENT</p> <p>I HEREBY ACKNOWLEDGE RECEIPT OF THE FOLLOWING CHECKED ADDENDUM(S) AND HAVE MADE THE NECESSARY REVISIONS TO MY PROPOSAL, PLANS AND/OR SPECIFICATION, ETC.</p>						

SEE REVERSE SIDE FOR TERMS AND CONDITIONS

NATURE	<i>Howard H. Harper</i>	TELEPHONE	<i>304-636-1194</i>	DATE	<i>9-30-2006</i>
E	<i>Owner</i>	FEIN	<i>55-0482970</i>	ADDRESS CHANGES TO BE NOTED ABOVE	

WHEN RESPONDING TO RFQ, INSERT NAME AND ADDRESS IN SPACE ABOVE LABELED 'VENDOR'



State of West Virginia
 Department of Administration
 Purchasing Division
 2019 Washington Street East
 Post Office Box 50130
 Charleston, WV 25305-0130

Request for Quotation

RFQ NUMBER
DEP13568

PAGE
8

ADDRESS CORRESPONDENCE TO ATTENTION OF:
CHUCK BOWMAN
304-558-2157

RFQ COPY
 TYPE NAME/ADDRESS HERE

VENDOR

SHIP TO

ENVIRONMENTAL PROTECTION
 DEPT. OF
 OFFICE OF SPECIAL RECLAMATION
 105 S. RAILROAD STREET
 PHILIPPI, WV
 26416-9998 304-457-3219

DATE PRINTED 08/16/2006	TERMS OF SALE	SHIP VIA	F.O.B.	FREIGHT TERMS
BID OPENING DATE: 10/03/2006		BID OPENING TIME 01:30PM		

LINE	QUANTITY	UOP	CAT. NO.	ITEM NUMBER	UNIT PRICE	AMOUNT
ADDENDUM NOS.:						
NO. 1						
NO. 2						
NO. 3						
NO. 4						
NO. 5						
I UNDERSTAND THAT FAILURE TO CONFIRM THE RECEIPT OF THE ADDENDUM(S) MAY BE CAUSE FOR REJECTION OF THE BIDS.						
					SIGNATURE	
Triple H. Construction					COMPANY	
September 30, 2006					DATE	
REV. 11/96						
CONTRACTORS LICENSE						
WEST VIRGINIA STATE CODE 21-11-2 REQUIRES THAT ALL PERSONS DESIRING TO PERFORM CONTRACTING WORK IN THIS STATE MUST BE LICENSED. THE WEST VIRGINIA CONTRACTORS LICENSING BOARD IS EMPOWERED TO ISSUE THE CONTRACTORS LICENSE. APPLICATIONS FOR A CONTRACTORS LICENSE MAY BE MADE BY CONTACTING THE WEST VIRGINIA DIVISION OF LABOR CAPITOL COMPLEX, BUILDING 3, ROOM 319, CHARLESTON, WV 25305. TELEPHONE: (304) 558-7890.						

SEE REVERSE SIDE FOR TERMS AND CONDITIONS

SIGNATURE <i>Howard H. Harper</i>	TELEPHONE 304-636-1194	DATE 9-30-2006
TITLE Owner	FEIN 55-0482970	ADDRESS CHANGES TO BE NOTED ABOVE

WHEN RESPONDING TO RFQ, INSERT NAME AND ADDRESS IN SPACE ABOVE LABELED 'VENDOR'



State of West Virginia
 Department of Administration
 Purchasing Division
 2019 Washington Street East
 Post Office Box 50130
 Charleston, WV 25305-0130

Request for Quotation

RFQ NUMBER
DEP13568

PAGE
9

ADDRESS CORRESPONDENCE TO ATTENTION OF:
CHUCK BOWMAN 304-558-2157

VENDOR

RFQ COPY
 TYPE NAME/ADDRESS HERE

SHIP TO

ENVIRONMENTAL PROTECTION
 DEPT. OF
 OFFICE OF SPECIAL RECLAMATION
 105 S. RAILROAD STREET
 PHILIPPI, WV
 26416-9998 304-457-3219

DATE PRINTED 08/16/2006	TERMS OF SALE	SHIP VIA	F.O.B.	FREIGHT TERMS
----------------------------	---------------	----------	--------	---------------

BID OPENING DATE: 10/03/2006 BID OPENING TIME 01:30PM

LINE	QUANTITY	UOP	CAT. NO.	ITEM NUMBER	UNIT PRICE	AMOUNT
<p>WEST VIRGINIA STATE CODE 21-11-11 REQUIRES ANY PROSPECTIVE BIDDER TO INCLUDE THE CONTRACTORS LICENSE NUMBER ON THEIR BID.</p> <p>BIDDER TO COMPLETE:</p> <p>CONTRACTORS NAME: <i>Triple H. Construction Company</i></p> <p>CONTRACTORS LICENSE NO.: <i>WV000949</i></p> <p>THE SUCCESSFUL BIDDER WILL BE REQUIRED TO FURNISH A COPY OF THEIR CONTRACTORS LICENSE PRIOR TO ISSUANCE OF A PURCHASE ORDER/CONTRACT</p> <p>APPLICABLE LAW</p> <p>THE WEST VIRGINIA STATE CODE, PURCHASING DIVISION RULES & REGULATIONS, PURCHASING DIVISION POLICY STATEMENTS, AND THE INFORMATION PROVIDED IN THE "REQUEST FOR QUOTATION" ISSUED BY THE PURCHASING DIVISION IS THE SOLE AUTHORITY GOVERNING THIS PROCUREMENT.</p> <p>ANY INFORMATION PROVIDED IN SPECIFICATION MANUALS, OR ANY OTHER SOURCE, VERBAL OR WRITTEN, WHICH CONTRADICTS OR ALTERS THE INFORMATION PROVIDED FROM THE SOURCES AS DESCRIBED IN THE ABOVE PARAGRAPH IS VOID AND OF NO EFFECT.</p> <p>NOTICE</p> <p>AN ORIGINAL, SIGNED BID MUST BE SUBMITTED TO:</p>						

SEE REVERSE SIDE FOR TERMS AND CONDITIONS

NATURE <i>Howard H. Hays</i>	TELEPHONE <i>304-636-1194</i>	DATE <i>9-30-2006</i>
OWNER <i>Owner</i>	PEIN <i>55-0482970</i>	ADDRESS CHANGES TO BE NOTED ABOVE

WHEN RESPONDING TO RFQ, INSERT NAME AND ADDRESS IN SPACE ABOVE LABELED 'VENDOR'



State of West Virginia
 Department of Administration
 Purchasing Division
 2019 Washington Street East
 Post Office Box 50130
 Charleston, WV 25305-0130

Request for Quotation

RFQ NUMBER
 DEP13568

PAGE
 10

ADDRESS CORRESPONDENCE TO ATTENTION OF:
 CHUCK BOWMAN
 304-558-2157

RFQ COPY

TYPE NAME/ADDRESS HERE

SHIP TO

ENVIRONMENTAL PROTECTION
 DEPT. OF
 OFFICE OF SPECIAL RECLAMATION
 105 S. RAILROAD STREET
 PHILIPPI, WV
 26416-9998 304-457-3219

DATE PRINTED 08/16/2006	TERMS OF SALE	SHIP VIA	F.O.B.	FREIGHT TERMS
----------------------------	---------------	----------	--------	---------------

BID OPENING DATE: 10/03/2006 BID OPENING TIME 01:30PM

LINE	QUANTITY	UOP	CAT NO.	ITEM NUMBER	UNIT PRICE	AMOUNT
				DEPARTMENT OF ADMINISTRATION PURCHASING DIVISION BUILDING 15 2019 WASHINGTON STREET, EAST CHARLESTON, WV 25305-0130		
THE BID MUST CONTAIN THIS INFORMATION ON THE FACE OF THE ENVELOPES OR THE BID MAY NOT BE CONSIDERED: SEALED BID BUYER: CB-23 REQ. NO.: DEP13568 BID OPENING DATE: 10/03/2006 BID OPENING TIME: 1:30 PM ENTER FAX # & CONTACT NAME FOR ANY BID CLARIFICATION. PRINT THIS INFORMATION IN THE SPACE BELOW THIS LINE.						
***** THIS IS THE END OF RFQ DEP13568 ***** TOTAL:						<i>\$ 450,000⁰⁰</i>
				<i>304-335-8234 (FAX#)</i> <i>Howard H. Harper</i>		

SEE REVERSE SIDE FOR TERMS AND CONDITIONS

SIGNATURE <i>Howard H. Harper</i>	TELEPHONE <i>304-636-1194</i>	DATE <i>9-30-2006</i>
TITLE <i>Owner</i>	FAX <i>55-0482970</i>	ADDRESS CHANGES TO BE NOTED ABOVE

WHEN RESPONDING TO RFQ, INSERT NAME AND ADDRESS IN SPACE ABOVE LABELED 'VENDOR'

BUYER CB-23	PAGE 011	REQ. OR PO NO. DEP13568
SPENDING UNIT WEST VIRGINIA DEPARTMENT OF ENVIRONMENTAL PROTECTION/SPECIAL RECLAMATION		

WV-36a STATE OF WEST VIRGINIA
 Rev. 1/29/02 PURCHASING CONTINUATION SHEET
 VENDOR:

SCOPE OF WORK

The successful bidder shall provide appropriate equipment, materials, labor and any technical services needed for the successful reclamation of DAUGHERTY COAL COMPANY, INC., Permit 65-77, and any disturbance associated with such operation. The General Performance Standards (GPS) shall apply to all items in Scope of Work.

Work necessary on this site will include the following items, but is not limited to these:

1. Upon mobilization to the site, which will be directed in a written Notice to Proceed, the access roads shall be developed in accordance with bid item #3 & 4. If, fuel and lubricants are to be stored on site, bid item # 2 shall be in place before fuel is delivered. The project sign is to be obtained and installed at the beginning of the project.
2. Storm water management in the form as described in bid item # 8 shall be installed (described locations).
3. Revegetation and soil improvements are required for areas designated at pre-bid meeting. Reclamation is to be according to the attached specifications, plans, and clarifying discussions at the Pre-Bid Conference.
4. Construct open limestone channels (OLCs).
5. Construct seep collectors.
6. Prepare and construct foundation and install aquafix and silo at one site.
7. Construct roadside riprap ditches.
8. Replace and install road culverts.
9. Dewater pond site #3.
10. Eliminate pond #3.
11. Upgrade existing access roads.
12. Construct new access road.
13. Any other site specific items required.

I, David B. McCoy, the undersigned, hereby certify ¹ that this Reclamation Plan is correct and shows to the best of my knowledge and belief all the information required by the surface mining laws of the State of West Virginia. The source of information was the approved mining and reclamation plan contained in the forfeited surface mine permit, existing site conditions and information contained in the WV DEP, Inspection and Enforcement files.

David B. McCoy
 Registered Professional Engineer WV No. 14375

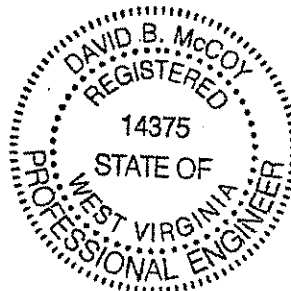

DBS
 7/14/06

Date: 7/13/2006

¹ The term "certify" as used herein is defined as follows: An engineer's certification of conditions is a declaration of professional judgment. It does not constitute a warranty or guarantee, either expressed or implied.

BUYER CB-23	PAGE 012	REQ. OR PO NO. DEP13568
SPENDING UNIT WEST VIRGINIA DEPARTMENT OF ENVIRONMENTAL PROTECTION/SPECIAL RECLAMATION		

WV-36a STATE OF WEST VIRGINIA
 Rev. 1/29/02 PURCHASING CONTINUATION SHEET
 VENDOR:

ITEM NO.	QUANTITY	DESCRIPTION	UNIT PRICE	AMOUNT
BID SCHEDULE				
PERMIT NAME: <u>DAUGHERTY COAL COMPANY,</u> <u>INC.</u>				
PERMIT NUMBER(S): <u>65-77</u>				
1.0	LUMP SUM	<u>MOBILIZATION/DEMObILIZATION/PROJECT SIGN</u> (5% Total Bid Maximum for this permit)	LUMP SUM	\$ <u>21,000</u>
2.0	LUMP SUM	<u>SPILL CONTAINMENT AREA (S.C.A.)</u> (\$1,000.00 Maximum Bid for this permit)	LUMP SUM	\$ <u>100</u>
3.0	<u>2360</u> LF	<u>ACCESS ROAD UPGRADE</u>	\$ <u>12.⁵⁰</u> PER LF	\$ <u>29,500</u>
4.0	<u>1115</u> LF	<u>CONSTRUCT NEW ACCESS ROAD</u>	\$ <u>29.⁰⁰</u> PER LF	\$ <u>32,335</u>
5.0	LUMP SUM	<u>ROAD ACCESS PIPE GATE (TWO 9' GATES)</u>	LUMP SUM	\$ <u>10,000</u>
6.0	<u>40</u> LF	<u>30 INCH CULVERT</u>	\$ <u>100.⁰⁰</u> PER LF	\$ <u>4,000</u>
7.0	LUMP SUM	<u>ROCK LINED PLUNGE POOL</u>	LUMP SUM	\$ <u>5,000</u>
8.0	<u>240</u> LF	<u>12 INCH CULVERT</u>	\$ <u>40.⁰⁰</u> PER LF	\$ <u>9,600</u>
9.0		<u>REVEGETATION</u>		
9.1	<u>4</u> AC	<u>AGRICULTURAL LIME</u>	\$ <u>500.⁰⁰</u> PER ACRE	\$ <u>2,000</u>
9.2	<u>4</u> AC	<u>FERTILIZER</u>	\$ <u>500.⁰⁰</u> PER ACRE	\$ <u>2,000</u>
9.3	<u>4</u> AC	<u>MULCH</u>	\$ <u>500.⁰⁰</u> PER ACRE	\$ <u>2,000</u>
9.4	<u>4</u> AC	<u>VEGETATIVE SPECIES</u>	\$ <u>500.⁰⁰</u> PER ACRE	\$ <u>2,000</u>

BUYER CB-23	PAGE 013	REQ. OR PO NO. DEP13568
SPENDING UNIT WEST VIRGINIA DEPARTMENT OF ENVIRONMENTAL PROTECTION/SPECIAL RECLAMATION		

WV-36a STATE OF WEST VIRGINIA
 Rev. 1/29/02 PURCHASING CONTINUATION SHEET
 VENDOR:

ITEM NO.	QUANTITY	DESCRIPTION	UNIT PRICE	AMOUNT
10.0	1600 LF	<u>HAYBALE DIKE</u> (Max. Bid \$5.00 Per LF)	\$ <u>5⁰⁰</u> PER LF	\$ <u>8,000</u>
11.0	20 LF	<u>SEEP COLLECTOR #1</u>	\$ <u>125⁰⁰</u> PER LF	\$ <u>2,500</u>
12.0	260 LF	<u>SEEP COLLECTOR #2</u>	\$ <u>125⁰⁰</u> PER LF	\$ <u>32,500</u>
13.0	50 LF	<u>SEEP COLLECTOR #3</u>	\$ <u>125⁰⁰</u> PER LF	\$ <u>6,250</u>
14.0	220 LF	<u>2 INCH WATER INTAKE LINE TO DRIVE UNIT</u>	\$ <u>12⁰⁰</u> PER LF	\$ <u>2,640</u>
15.0	1240 LF	<u>4 INCH WATER INTAKE LINE TO DRIVE UNIT</u>	\$ <u>18⁰⁰</u> PER LF	\$ <u>22,320</u>
16.0	850 LF	<u>OPEN LIMESTONE CHANNEL #1</u>	\$ <u>18⁰⁰</u> PER LF	\$ <u>15,300</u>
17.0	900 LF	<u>OPEN LIMESTONE CHANNEL #2</u>	\$ <u>14⁰⁰</u> PER LF	\$ <u>12,600</u>
18.0	120 LF	<u>ROADSIDE RIPRAP DITCH A</u>	\$ <u>9⁰⁰</u> PER LF	\$ <u>1,080</u>
19.0	1015 LF	<u>ROADSIDE RIPRAP DITCH B</u>	\$ <u>30⁰⁰</u> PER LF	\$ <u>30,450</u>
20.0	LUMP SUM	<u>POND #3 DEWATERING</u>	LUMP SUM	\$ <u>5,000</u>
21.0	LUMP SUM	<u>POND #3 ELIMINATION</u>	LUMP SUM	\$ <u>10,000</u>
22.0	300 TON	<u>INCIDENTAL 3/4 CRUSHER RUN STONE FOR EXISTING ROADS</u>	\$ <u>25⁰⁰</u> PER TON	\$ <u>7,500</u>
23.0	200 TON	<u>INCIDENTAL #8 STONE FOR EXISTING ROADS</u>	\$ <u>25⁰⁰</u> PER TON	\$ <u>5,000</u>
24.0	260 LF	<u>6 INCH PVC SOLID PIPE</u>	\$ <u>15⁰⁰</u> PER LF	\$ <u>3,900</u>
25.0	20 LF	<u>12 INCH PVC SOLID PIPE</u>	\$ <u>25⁰⁰</u> PER LF	\$ <u>500</u>
26.0	10 LF (Depth)	<u>SUB-FOUNDATION PREPARATION</u>	\$ <u>800⁰⁰</u> PER LF	\$ <u>8,000</u>

BUYER CB-23	PAGE 014	REQ. OR PO NO. DEP13568
SPENDING UNIT WEST VIRGINIA DEPARTMENT OF ENVIRONMENTAL PROTECTION/SPECIAL RECLAMATION		

WV-36a STATE OF WEST VIRGINIA
 Rev. 1/29/02 PURCHASING CONTINUATION SHEET
 VENDOR:

ITEM NO.	QUANTITY	DESCRIPTION	UNIT PRICE	AMOUNT
27.0	LUMP SUM	<u>FOUNDATION</u>	LUMP SUM	\$ <u>10,000</u>
28.0	LUMP SUM	<u>CRANE</u>	LUMP SUM	\$ <u>1,000</u>
29.0	LUMP SUM	<u>DOSING UNIT AND SILO</u>	LUMP SUM	\$ <u>145,925</u>
TOTAL PERMIT <u>65-77</u>				\$ <u>450,000⁰⁰</u>

BUYER CB-23	PAGE 015	REQ. OR PO NO. DEP13568
SPENDING UNIT WEST VIRGINIA DEPARTMENT OF ENVIRONMENTAL PROTECTION/SPECIAL RECLAMATION		

WV-36a STATE OF WEST VIRGINIA
 Rev. 1/29/02 PURCHASING CONTINUATION SHEET
 VENDOR:

BID ITEM TECHNICAL SPECIFICATIONS

1.0 MOBILIZATION/DEMobilIZATION/PROJECT SIGN
PROJECT SIGN

A project sign shall be obtained or manufactured and installed as indicated on the attached specifications and details. Payment for this sign shall be incidental to the mobilization item. No separate payment will be made.

MOBILIZATION

This work shall consist of the performance of construction preparatory operations, including the movement of personnel, equipment and other facilities to the project site necessary to begin work on a substantial phase of the contract.

DEMobilIZATION

Prior to demobilization, an inspection shall be conducted by the Department of Environmental Protection and the contractor to insure compliance with contract performance. Once compliance is ascertained, demobilization activities can be initiated and completed. Demobilization shall be totally completed before the invoice for payment shall be processed.

PAYMENT

The lump sum bid for this item shall not exceed 5% of the total bid for this permit. Payment shall be made in two 50% amounts, one upon completion of the mobilization and project sign items and the second payment at the completion of demobilization. No deduction shall be made nor shall any increase be made in the lump sum item amount, regardless of decreases or increases in the final total contract amount or any other reason.

2.0 SPILL CONTAINMENT AREA (S.C.A.)

Spill containment measures shall be used for fuel and lubricant storage areas. All containers, barrels, buckets, cans, etc., are to be legally disposed of off site. Used lubricants are to be disposed of according to state law to minimize pollution to the local surface and ground water supplies. Spills are the responsibility of the contractor and need immediate clean up and maintained at no expense to the State. This S.C.A. shall be constructed in accordance with the typical drawing specification (See Attachment). Alternate containment measures will be considered for approval by the Program Manager if acceptable results can be shown. Fuel tanks manufactured with secondary containment are desirable. Minimum secondary containment is 110 percent. (Bid limited to \$1,000.00 maximum)

3.0 ACCESS ROAD UPGRADE

The contractor shall maintain the existing access road (~2360 LF) during the reclamation process to provide access on a well drained surface. This road is currently used as an access road for the adjacent landowner. The access road shall be maintained to drain and provide a road surface free of excessive mud and standing waters at all times while work is in progress. Upon completion of all reclamation activities, the road shall be graded, as needed, in areas designated by the DEP on-site representative, and a final layer of 1½ inch crusher run limestone shall be placed in a three (3) inch minimum layer on the existing road. The completed road shall have a minimum width of twelve (12) feet and the surface shall be crowned and sloped to the both sides a minimum of 24-horizontal to 1 vertical. A roadside drainage ditch shall be established and/or maintained along the hillside of the road, and shall be free draining to any culverts crossing under the road. The ditch shall be vegetated and constructed as indicated in the New Access Road drawing. Dust-control measures may be necessary if hauling creates airborne material. Payment shall be for completed length of road upgrade.

BUYER CB-23	PAGE 016	REQ. OR PO NO. DEP13568
SPENDING UNIT WEST VIRGINIA DEPARTMENT OF ENVIRONMENTAL PROTECTION/SPECIAL RECLAMATION		

WV-36a STATE OF WEST VIRGINIA
 Rev. 1/29/02 PURCHASING CONTINUATION SHEET
 VENDOR:

4.0 CONSTRUCT NEW ACCESS ROAD

This required road will be approximately 1115 LF. Accompanying plans show the details of the construction of the road. The contractor shall provide all services, materials, construction layout, equipment, or other materials necessary to execute the work. Payment shall be for completed length of road.

SITE PREPARATION

Any areas with soft unsuitable foundation materials shall be undercut to remove this material. The material removed shall be disposed of within the construction area at a site agreed to between the contractor and the DEP on site representative. Construction stake out shall be completed as necessary to complete that phase of the work being undertaken. Payment for the construction stakeout is to be included in the road price. No separate payment will be made for construction stake out.

ROAD CONSTRUCTION

Suitable foundation material shall then be placed in compacted layers not to exceed six (6) inches in thickness to obtain the desired grade and alignment. Compaction equipment is to be approved by DEP on site representative. Filter Fabric (Tyvar 3401, Mirafi 500X, or equivalent) shall be placed over the completed foundation and covered with a six (6) inch minimum layer of No. 1 limestone (3½ to 1½ inches). The No. 1 stone shall then be covered with 1½ inch crusher run limestone so that the surface is choked off and a two (2) inch minimum layer remains on top. The completed road shall have a minimum width of twelve (12) feet and the surface shall be crowned and sloped to both sides a minimum of 24-horizontal to 1 vertical. Any fill sections, if used, shall not impound water. Payment shall be made at the unit price for the measured length completed. The total length of roadside ditch shall be along the entire length of the newly constructed road. A roadside drainage ditch shall be established along the hillside of the road, and shall be free draining to any culverts crossing under the road. The ditch shall be vegetated and constructed as indicated in the New Access Road drawing. The roadside ditch will drain in two directions. The most appropriate drainage divide will be determined during construction activities.

Payment shall be for completed length of road, and shall include a truck turn-around area paid as length of road (204 LF). The turn-around area shall be approximately twenty four (24) feet wide and ninety (90) feet in length with twelve (12) feet wide corners totaling 2448 sq.ft., see Truck Turn-around Detail drawing. The turn-around area location shall be designated by the DEP on-site representative.

5.0 ROAD ACCESS GATES

All gate hardware shall be hot-dipped galvanized as per ASTM A153 specifications for zinc coating (hot dip) on iron and steel hardware. The pipe gates and posts shall be painted. The preferred color is green. Gate posts shall be a minimum of four (4) inch diameter and seven (7) feet long. Post holes shall be a minimum of four (4) ft. deep and twelve (12) inch in diameter or square. Sides shall be nearly vertical. Posts shall be embedded in concrete, and filled with concrete. At least twelve (12) inches of concrete shall be placed below the post. Concrete shall have a minimum of 28-day test strength of 4000 psi. All pipe on the gates shall have the ends welded closed.

Posts shall be braced to support the weight of the gate. Conventional bracing with use of wire cable and adjustable turnbuckles shall be used. The support posts shall be set to the same specifications as the main gate posts, and shall be a minimum of one (1) foot above grade. Pipe hinge pins shall be made from 1 ½" I.D. steel line pipe (pipe O.D.= 1 7/8"). Pipe gates shall be constructed with 2 inch I.D. diameter steel line pipe with a wall thickness of 0.188" (pipe O.D.= 2 3/8"). Two 9 ft. pipe gates shall be installed at the site to provide an opening of 18 feet. Provide a lockable latch, which includes a two-lock mechanism and protection for both locks. The lock box shall be welded to one side of the gate pipe. Grease fittings shall be installed on the four hinge points. See the Pipe Gate Detail drawing. All hardware and/or accessories necessary for installation of gates shall be part of this lump sum bid price. An equivalent type of lock guard and hinge detail may be accepted upon approval of the DEP Engineer or on-site representative.

Gates will be installed near the intersection of the access road and the county road. Additional on-site

BUYER CB-23	PAGE 017	REQ. OR PO NO. DEP13568
SPENDING UNIT WEST VIRGINIA DEPARTMENT OF ENVIRONMENTAL PROTECTION/SPECIAL RECLAMATION		

WV-36a STATE OF WEST VIRGINIA
 Rev. 1/29/02 PURCHASING CONTINUATION SHEET
 VENDOR:

existing rock materials shall be placed on each side of gates to protect from bypassing around the gates. Placement of large rock material shall be incidental to this bid item. Payment shall be made at the completion of installation and acceptance by the DEP.

6.0 30-INCH CULVERT

The forty (40) feet length of culverts shall be HDPE, dual wall smooth interior corrugated twenty (20) foot joint type. The pipe joints shall be silt-tight and the pipe shall meet ASTM D3350 manufacturing standards.

This culvert shall be placed in the dip of the road, replacing a smaller concrete culvert, and the pipe shall be installed perpendicular to the road with a 2~3% drainage slope.

Culvert inlet end shall be protected by a headwall of stable non-erodible material and the slope at the outlet shall be protected with an apron of rock riprap, energy dissipater or other designated material. The culvert shall be installed in a trench excavated in solid undisturbed ground or formed by compacted earth.

The culvert shall be imbedded in a formed trench to a depth no less than 1/10 the outside diameter of the pipe. Selected backfill material shall be placed around the culvert in four (4) inch layers and thoroughly compacted by means of hand tamping or manually directed power tampers or plate vibrators.

Culvert shall be covered with a minimum of twelve (12) inches or one-half the culvert diameter whichever is greater. Payment shall be for completed length of culverts.

7.0 ROCK LINED PLUNGE POOL

This compacted earth dike shall be constructed below the outflow of the 30 inch road culvert in bid item #5.0. The constructed earth semi-circular dike shall have a top width of five (5) feet. Excess materials from all three seep collectors and from the new access road may be used for construction of the earth embankment. The inner slopes of the constructed earth embankment and the exit channels shall be lined with filter fabric and riprap to prevent soil erosion. See the attached drawing for specific information on Plunge Pool Channels.

Lump sum payment shall be for construction of a compacted earth plunge pool on the exit end of the culvert, lined with limestone rock riprap exit channels, set to specific elevations as specified by the DEP onsite representative. The filter fabric, and limestone riprap used to line the exit channel and the culvert outlet will be incidental to this lump sum bid item.

8.0 12-INCH CULVERT

Culvert shall be HDPE, dual wall smooth interior corrugated twenty (20) foot joint type. The pipe joints shall be silt-tight and the pipe shall meet ASTM D3350 manufacturing standards.

Culverts installed in sloped areas of the access road shall cross the road at a 30 degree angle downgrade with a minimum grade of three percent (3%) from inlet to outlet. Where culverts are placed in the dip of the road the pipe shall be installed perpendicular to the road.

Culvert inlet end shall be protected by a headwall of stable non-erodible material and the slope at the outlet shall be protected with an apron of rock riprap, energy dissipater or other designated material. The culvert shall be installed in a trench excavated in solid undisturbed ground or formed by compacted earth.

The culvert shall be imbedded in a formed trench to a depth no less than 1/10 the outside diameter of the pipe. Selected backfill material shall be placed around the culvert in four (4) inch layers and thoroughly compacted by means of hand tamping or manually directed power tampers or plate vibrators.

Culvert shall be covered with a minimum of twelve (12) inches or one-half the culvert diameter whichever is greater. Three culverts shall be installed along the wooded area of the "Road Access Upgrade" portion of the road. Three culverts shall be installed on the New Access road. Three 40 ft culverts shall be installed near the three existing ponds. The specific culvert locations shall be designated by the DEP on-site representative.

Payment shall be for completed length of culverts.

BUYER CB-23	PAGE 018	REQ. OR PO NO. DEP13568
SPENDING UNIT WEST VIRGINIA DEPARTMENT OF ENVIRONMENTAL PROTECTION/SPECIAL RECLAMATION		

WV-36a STATE OF WEST VIRGINIA
 Rev. 1/29/02 PURCHASING CONTINUATION SHEET
 VENDOR:

9.0 REVEGETATION

All bare areas as discussed at the pre-bid meeting, and areas affected by construction activities shall be revegetated.

The actual seeding date, within the work performance period, shall be at the discretion of the contractor, but a permanent vegetative cover must be established. Verification of materials used shall be required for payment. Seed bed preparation, unless otherwise approved, shall be conducted by industrial disks or tracking with heavy equipment with cleat marks across slope and parallel to the final contours. The surface shall be tracked, track to track. Seeding shall commence after seedbed preparation on a loose and uncompacted soil and with the approval of the Department of Environmental Protection. Contractor shall provide equipment as necessary to secure approval of the seedbed. Revegetation activities shall be carried out in a continuous, concurrent, timely and uniform manner. Failure to do this may result in nonpayment for portions of or the entire Revegetation item. Hydroseeding or broadcast seeding with the approved species is acceptable. The application rate may be increased but the ratio is to remain constant, but no additional monetary compensation will be awarded. Areas outside the limits of construction, disturbed by the contractor, shall be revegetated by the contractor at no expense to DEP. Water utilized for hydroseeding shall be free of injurious or other toxic substances harmful to plant life. The source of water is subject to the approval of the DEP Specialist. It shall be the vendor's responsibility to repeat the procedures under REVEGETATION until a permanent vegetation is established. The acreage quantities in this contract are for bidding purposes only.

A warranty period of one (1) year shall commence upon completion and payment of the revegetation item of the contract. No payment will be made for additional seeding necessary to comply with warranty requirements. The warranty period will be extended for one (1) year from the date of the last augmented seeding done by the contractor. The performance bond and labor and materials bond shall remain in effect throughout the warranty period. The Standards for Evaluating Vegetative Cover as presented in Title 38, CSR2, Section 9 of the West Virginia Surface Mining Reclamation Regulations will apply.

Equipment for the retracking/scarification to eliminate rills and gullies shall be mobilized and utilized to produce slopes consistent with the regrading and topsoiling bid item prior to warranty reseeding. No additional payment will be made by DEP for this warranty work.

9.1 AGRICULTURAL LIME

Use of blends and low-grade agricultural liming materials shall require prior approval. Lime shall be spread as soon as possible after delivery to site. Lime shall be applied evenly and uniformly distributed over the treated area. Lime shall be thoroughly mixed into the soil material. Lime subjected to adverse conditions before spreading will be deemed unacceptable. Failure to complete this phase shall result in nonpayment of this bid item.

Lime Applied at 10 ton/acre.

9.2 FERTILIZER

Fertilizer rates given for REVEGETATION are for 1000 lbs. of 10-20-20 per acre. These rates are minimum and for bidding purposes.

Fertilizer shall be applied evenly and uniformly distributed over the treated area. Common complete fertilizers that meet the minimum standards are acceptable.

9.3 MULCH

Acceptable mulch for this project is wood fiber, hay, or straw.

Mulch: Wood Fiber @ 1.0 ton/Acre

Hay or straw mulch may be substituted at a rate of 2 tons/Acre.

WV-36a STATE OF WEST VIRGINIA
 Rev. 1/29/02 PURCHASING CONTINUATION SHEET
 VENDOR:

9.4 VEGETATIVE SPECIES

Seeding rate required is for pure live seed (pls) in pounds per acre. The use of annuals or cover crops will not be considered for vegetative success.

NORTH MIX

<u>VEGETATIVE SPECIES</u> ¹	<u>RATE/ACRE</u> ¹
Orchard Grass	@ 15 lbs/acre
Birdsfoot Trefoil ²	@ 15 lbs/acre
Yellow Sweet Clover	@ 5 lbs/acre
Red Clover	@ 10 lbs/acre
Ky 31 Fescue	@ 15 lbs/acre
Foxtail Millet ³	@ 12 lbs/acre
Wheat or Rye ⁴	@ 50 lbs/acre

1. Seeding rate suggested is for pure live seed (pls) in pounds per acre.
2. Herbaceous legumes must be treated with the appropriate bacterium before seeding.
3. Spring mix.
4. Fall mix.

10.0 HAYBALE DIKE

Disturbed areas that have storm water runoff and does not pass through a sediment control structure shall utilize the following method to manage storm water runoff: Max. Bid of \$5.00/LF of Hay Bale Dike.

1. All bales shall be placed on the contour.
2. Bales shall be placed in a row with ends tightly abutting the adjacent bales.
3. Bales shall be securely anchored in place by stakes or rebar driven through the bales. Rebar shall be removed at the direction of the DEP. The first stake in each bale shall be driven toward the previously laid bale to force the bales together. Construction of sumps may become necessary to supplement the hay bale dikes.

Continuous sediment control structures shall be placed in areas from the 30 inch culvert to the treatment unit, beside the new access road construction, and at all areas below culverts or ditch outlets during construction. These specific locations for sediment control are not to limited to any other locations deemed necessary by the contractor. Payment shall be for completed length of hay bales installed.

11.0 SEEP COLLECTOR #1

Provide all materials and construct seep collector #1 according to the attached typical plans, cross-section, specifications, and as discussed at the Pre-Bid Showing. The twelve-inch (12") SDR35 PVC pipe shall be perforated within the seep collector according to the detail drawing and specifications. The collector shall daylight as a solid pipe directly into OLC #1 with an animal guard on the end. The four-inch (4") HDPE water intake line, used to drive the unit, shall be perforated within the seep collector, but will exit as a solid pipe, leading directly to the treatment building. The four-inch HDPE line shall be converted to SDR35 PVC perforated type inside the seep collector, and shall extend above ground as a cleanout with an end cap. This pipe shall be buried with a minimum of two and one-

BUYER CB-23	PAGE 020	REQ. OR PO NO. DEP13568
SPENDING UNIT WEST VIRGINIA DEPARTMENT OF ENVIRONMENTAL PROTECTION/SPECIAL RECLAMATION		

WV-36a STATE OF WEST VIRGINIA
Rev. 1/29/02 PURCHASING CONTINUATION SHEET
VENDOR:

half (2.5') feet of cover to prevent the line from freezing. The four-inch (4") HDPE is not included in this bid item but is included as a separate bid item (#~~150~~). Payment for seep conveyance drain shall be by the linear foot installed, and shall include any perforated pipe, fittings, and cleanouts within the seep collector. Any solid pipe required to daylight the water to ditches shall be a separate bid item (#~~250~~).

12.0 SEEP COLLECTOR #2

Provide all materials and construct seep collector #2 according to the attached typical plans, cross-section, specifications, and as discussed at the Pre-Bid Showing. The six-inch (6") SDR35 PVC shall be perforated within the seep collector according to the seep collector #2 & #3 detail drawing and shall daylight as a solid pipe directly into OLC #1 with an animal guard on the end. The length of six (6") inch solid pipe exiting the seep collector is included under bid item (#~~210~~). Payment for seep collector drain shall be by the linear foot installed.

13.0 SEEP COLLECTOR #3

Provide all materials and construct seep collector #3 according to the attached typical plans, cross-section, specifications, and as discussed at the Pre-Bid Showing. The six-inch (6") SDR35 PVC pipe shall be perforated within the seep collector according to the seep collector #2 & #3 detail drawing and shall daylight as a solid pipe directly into OLC #2 with an animal guard on the end. The solid six-inch (6") PVC is not included in this bid item but is included as a separate bid item (#~~210~~). The two-inch (2") SDR35 PVC water intake line, used to drive the unit, shall be perforated within the seep collector, but will exit as a solid pipe, leading directly to the treatment building. Also, the two-inch (2") PVC line shall extend above ground as a cleanout with an end cap. Any elbow fittings shall be the long sweep type. The two-inch pipe shall be buried with a minimum of two and one-half (2.5') feet of cover to prevent the line from freezing. The solid two-inch (2") SDR35 PVC is not included in this bid item but is included as a separate bid item (#~~140~~). Payment for seep conveyance drain shall be by the linear foot installed, and shall include any perforated pipe, fittings, and cleanouts within the seep collector.

14.0 2 INCH WATER INTAKE LINE TO DRIVE UNIT

One (1) PVC 2 inch water line (gasket joint type) shall be provided to connect seep collector #3 (see details) to the control valve on the dispensing unit. The line shall be buried with a minimum of two and one-half (2.5') feet of cover to avoid freezing. Any elbow fittings shall be long sweep type. Approximately 220 linear feet will be required. Payment shall be made for the actual measured length of pipe installed.

15.0 4 INCH WATER INTAKE LINE TO DRIVE UNIT

One (1) HDPE (DR 15.5 or 17) 4 inch diameter water line shall be provided to connect seep collector #1 (see details) to the control valve on the dispensing unit. The line shall be buried with a minimum of two and one-half (2.5') feet of cover to avoid freezing. Approximately 1240 linear feet will be required. The line shall have three (3) wye cleanouts with threaded caps, evenly spaced along the length of the line. The line shall be reduced to a 2 inch diameter PVC line within five (5) feet of the treatment unit. Also, a "true union" ball type shut-off valve shall be located in this 5 ft. section of line. Payment shall be made for the actual measured length of pipe installed. Cleanouts, molded elbows, caps, reducer fittings, and valves shall be incidental to this bid item.

16.0 OPEN LIMESTONE CHANNEL #1

Provide all materials, excavate and construct the open limestone channel as indicated on the attached typical plans, cross-section, specifications, and as discussed at the Pre-Bid Showing (See riprap specifications). Ditches shall be free draining upon completion of construction. Length of ditch may be adjusted to meet on site conditions. Payment shall be made by the linear foot.

17.0 OPEN LIMESTONE CHANNEL #2

Provide all materials, excavate and construct the open limestone channel as indicated on the attached typical

BUYER CB-23	PAGE 021	REQ. OR PO NO. DEP13568
SPENDING UNIT WEST VIRGINIA DEPARTMENT OF ENVIRONMENTAL PROTECTION/SPECIAL RECLAMATION		

WV-36a STATE OF WEST VIRGINIA
 Rev. 1/29/02 PURCHASING CONTINUATION SHEET
 VENDOR:

plans, cross-section, specifications, and as discussed at the Pre-Bid Showing (See riprap specifications). Ditches shall be free draining upon completion of construction. Length of ditch may be adjusted to meet on site conditions. Payment shall be made by the linear foot.

18.0 ROADSIDE RIPRAP DITCH A

Provide all materials, excavate and construct the open limestone channel as indicated on the attached typical plans, cross-section, specifications, and as discussed at the Pre-Bid Showing (See riprap specifications). Ditches shall be free draining upon completion of construction. Length of ditch may be adjusted to meet on site conditions. Payment shall be made by the linear foot.

19.0 ROADSIDE RIPRAP DITCH B

Provide all materials, excavate and construct the open limestone channel as indicated on the attached typical plans, cross-section, specifications, and as discussed at the Pre-Bid Showing (See riprap specifications). Ditches shall be free draining upon completion of construction. Length of ditch may be adjusted to meet on site conditions. Payment shall be made by the linear foot.

20.0 POND #3 DEWATERING

The pond water is to be treated to a pH between 6 and 9 and to have suspended solids which do not exceed 35 mg/liter before discharge. Discharge rates must be controlled (limited) so that stream bed erosion, flooding, and any other off-site impacts are prevented. Monitoring of the receiving stream shall be done at all times this work is in progress.

After the pond has been dewatered, construction of open channel seep collectors will be required to collect any excess ground water and channel away from the pond site. The riprap channels will be paid under bid item (#170).

Construction of a settling sump may be necessary for this water before discharge to the receiving stream.

Provide all chemicals, equipment, testing, personnel, or other items needed to complete this item. Lump sum payment shall be made upon completion of the dewatering of the pond.

21.0 POND #3 ELIMINATION

Once pond is dewatered, all sludge, mud, and sediment or undesirable material down to original ground is to be removed. The method of elimination can be chosen by the contractor as long as acceptable results are obtained. Material removed from the pond shall be disposed of at a site agreed to with the on-site DEP representative. Once dewatered, the disposal site shall be covered with material suitable for vegetative growth. The area shall then be revegetated.

Fill material is available adjacent to the pond site, and may be used with the elimination of the pond berm to fill the pond site.

Payment shall be made in two installments. One payment shall be at the completion of removal of material from the existing pond, and the second at the completion of regrading of the disposal area, and upon completion of backfill of pond site.

22.0 INCIDENTAL ¾ CRUSHER RUN STONE FOR EXISTING ROADS

During construction of seep collectors, culvert replacements, and roadway ditch improvements, the landowner's existing graveled roadways may be damaged and must be repaired. After any necessary re-compaction and re-grading work on roadways performed by the contractor, a three (3) inch layer of ¾ inch crusher run stone shall be placed as needed. This stone shall be graded and tracked in with a dozer or other equipment to achieve a compacted base for the final top layer of #8 (1/4 to 3/8 inch) graded limestone (separate bid item).

Payment shall be paid per ton of stone applied by weight ticket and will be made at completion of all work

BUYER CB-23	PAGE 022	REQ. OR PO NO. DEP13568
SPENDING UNIT WEST VIRGINIA DEPARTMENT OF ENVIRONMENTAL PROTECTION/SPECIAL RECLAMATION		

WV-36a STATE OF WEST VIRGINIA
Rev. 1/29/02 PURCHASING CONTINUATION SHEET
VENDOR:

and acceptance by DEP.

23.0 INCIDENTAL #8 STONE FOR EXISTING ROADS

During construction of seep collectors, culvert replacements, and roadway ditch improvements, the landowner's existing graveled roadways may be damaged and must be repaired. After any necessary re-compaction and re-grading work on roadways has been completed and a two (2) inch layer of ¾ inch crusher run stone has been applied, a three (3) inch layer of #8 stone shall be placed as the final layer. This stone shall be graded and tracked in with a dozer or other equipment to achieve a uniform appearance for the final top layer.

Payment shall be paid per ton of stone applied by weight ticket and will be made at completion of all work and acceptance by DEP.

24.0 6 INCH PVC SOLID PIPE

PVC (SDR-35) six (6) inch line (gasket joint type) shall be provided. Installation is to be according to the manufacturer's recommendations. Provide all materials, equipment, excavation and personnel necessary for installation. The pipe shall be buried with a minimum of two and one-half (2.5') feet of cover to avoid freezing. Payment shall be made for the actual measured length of pipe installed.

25.0 12 INCH PVC SOLID PIPE

PVC (SDR-35) twelve (12) inch line (gasket joint type) shall be provided. Installation is to be according to the manufacturer's recommendations. Provide all materials, equipment, excavation and personnel necessary for installation. The pipe shall be buried with a minimum of two and one-half (2.5') feet of cover to avoid freezing. Payment shall be made for the actual measured length of pipe installed.

26.0 SUB-FOUNDATION PREPARATION

The sub-foundation shall be undercut to remove all fill (unconsolidated material) down to a competent foundation as determined by the DEP on site representative. The sub-foundation shall be constructed in substantial conformity to the plans and/or specifications. The DEP on site representative shall be present during this work.

The sub-foundation material shall be suitable material free of particles larger than three inches in diameter and consist of granular material conforming to WVDOH specification 716.1.1.2. A bearing capacity of approximately 6 tons per square ft should be obtained.

Compaction shall be done with a suitable compactor to obtain approximately 98% Standard Proctor Density. Layers shall be six (6) inches or less in thickness before compaction is initiated. Moisture content of the fill material shall be controlled to obtain maximum compaction.

Payment shall be made for each one (1) foot depth of undercut required.

27.0 FOUNDATION

The foundation shall be Type II Sulfate Resistant Concrete and shall conform to the dimensions and shape shown in the detail drawings and specifications. Include all reinforcing bars with supports and anchor bolts as necessary. Provide all forms, personnel and equipment required for the placement, finishing, and curing of the concrete. The concrete shall be consolidated with use of an internal spud vibrator to liquefy the concrete so that entrapped air and water can come to the surface. Adverse weather conditions shall be avoided during completion of this item. WVDOH specifications for concrete shall apply to this item. Concrete shall cure for a minimum of 5 to 7 days before the silo may be erected in place. Excavation for the foundation is incidental to this item with no separate payment being made.

The channel in the foundation is to receive water from seep collector #1 by means of open limestone channel #2 (see bid item #12). After treatment with the reagent, the water will exit the foundation into open limestone channel #2(see bid item #13). This item shall be paid for as a lump sum item after completion of the foundation and acceptance by the DEP.

BUYER CB-23	PAGE 023	REQ. OR PO NO. DEP13568
SPENDING UNIT WEST VIRGINIA DEPARTMENT OF ENVIRONMENTAL PROTECTION/SPECIAL RECLAMATION		

WV-36a STATE OF WEST VIRGINIA
 Rev. 1/29/02 PURCHASING CONTINUATION SHEET
 VENDOR:

28.0 CRANE

This shall include furnishing a crane of sufficient capacity to unload and erect the silo structure on its foundation and to install the reagent dispensing unit. The silo is estimated to weigh less than 10 ton.

Payment for this work shall be made based on the lump sum contract and paid upon final acceptance by DEP.

29.0 DOSING UNIT AND SILO

This item includes all work necessary to purchase, install and initiate operation of an Aquafix water powered dosing unit (Unit type MSS-SM-OA-50). This item shall be subcontracted to:

Aqua-Fix Water Treatment Systems.
 Michael Jenkins
 301 Maple Lane
 Kingwood, WV 26537 Telephone: (304) 329-1056.

Structural elements shall be warranted by the manufacturer to withstand normal static and dynamic loads as commonly accepted by industry. Changes to these specifications shall be made only with the written approval of the Program Manager.

A 50 ton steel silo to store the reagent is required. The silo shall be equipped with an interior ladder, an exterior ladder with a protective cage and a lockable steel safety door, a steel safety fence around the top of the silo, and a filler pipe to extend to the unloading port. A steel cone shall be placed at the base of the silo to direct the discharge of the reagent through a steel flange, which is sized and located to accommodate the reagent dispensing unit. Silo shall include a vent pipe to prevent pressure buildup during filling. An emergency pop off valve shall be included in case the vent pipe malfunctions. Pneumatic filling of the silo is to be utilized.

An insulated steel security enclosure attached to the silo structure support system to protect the dosing unit from vandalism and the weather is required. The wall thickness of the silo enclosure shall be equivalent to the steel used in the construction of the silo. The enclosure shall be equipped with a hinged, lockable steel door of sufficient size to facilitate removal of the dosing unit for repair and/or future replacement. The enclosed structure shall be fitted with a propane heating unit with a capacity to prevent freezing of the dosing unit during the winter. The heater will include all needed piping, regulator and fittings to connect to the tank. A 100 gallon tank shall be included, and will need to be filled one time.

Painting of the silo and steel security enclosure shall be done in accordance with WVDOH Specification 711. Preferred colors are green and/or tan.

The dosing unit, silo, and filler pipe shall be designed to facilitate the use of Calcium Oxide (CaO) during the service life of the unit. A water line will be installed to power the water wheel. This portion of the work shall include the initial filling and the start up of the unit, at the direction of the Program Manager, to confirm that all units function as intended. Any repairs and/or adjustments required to the unloading system and dosing unit to allow them to function as designed shall be performed at no cost to the DEP. The system shall be operated successfully for a one-week period before acceptance by the DEP. All settling ponds and riprap ditches leading to them must be completed before testing is initiated. The Calcium Oxide shall be 50 tons in amount and delivered as scheduled by the on site DEP representative.

Payment for all of the work specified above shall be made based on the lump sum contract price.

BUYER CB-23	PAGE 027	REQ. OR PO NO. DEP13568
SPENDING UNIT WEST VIRGINIA DEPARTMENT OF ENVIRONMENTAL PROTECTION/SPECIAL RECLAMATION		

WV-36a STATE OF WEST VIRGINIA
 Rev. 1/29/02 PURCHASING CONTINUATION SHEET
 VENDOR:

BID PREPARATION INFORMATION

HISTORICAL INFORMATION

Prospective bidders may review files at the West Virginia Department of Environmental Protection, Charleston, WV office, or the Regional West Virginia Department of Environmental Protection Office at 105 South Railroad St., Philippi, WV 26416. These files may contain additional information not included in the contract documents including, but not limited to, permit applications, permits, inspection reports, environmental documents, permit violation history, geological and geotechnical information, probable hydrologic consequences, maps, modifications, NPDES information and other related data. Copies may be obtained upon request and payment of copying fees.

EXAMINATION OF BID PACKAGE AND SITE OF WORK

The bidder is required to examine, carefully, the bid package (plans, specifications, supplemental specifications, contract forms, etc.) and the site of the work contemplated. The submission of a bid shall be considered prima facie evidence that the bidder has made such examination and has judged for and satisfied themselves as to the character, quantity, and quality of work to be performed and the materials required to be furnished under the contract.

PREBID CONFERENCE

Only the prospective bidders on the sign-in sheet in attendance for the entire Pre-Bid Conference will be eligible to submit bids for consideration of this project.

VIDEO

The information given at the pre-bid showing by the project contact person or the assigned person shall be documented on video tape and shall be an integral part of this contract's requirements, but will not supersede the written contract.

INTENT OF CONTRACT

The intent of the contract is for the reclamation/restoration of forfeited mine lands as required by West Virginia Department of Environmental Protection. The contractor is to provide for the construction and completion in every detail of the work described. The Contractor shall furnish all labor, materials, equipment, tools, transportation, and supplies required to complete the work in accordance with the Plans, Specifications, and terms of the Contract.

Should any misunderstanding arise as to the intent or meaning of the Contract, or any discrepancy appear, the decision of the Director of Division of Land Restoration shall be final.

BUYER CB-23	PAGE 025	REQ. OR PO NO. DEP13568
SPENDING UNIT WEST VIRGINIA DEPARTMENT OF ENVIRONMENTAL PROTECTION/SPECIAL RECLAMATION		

WV-36a STATE OF WEST VIRGINIA
 Rev. 1/29/02 PURCHASING CONTINUATION SHEET
 VENDOR:

GENERAL PERFORMANCE STANDARDS

INTRODUCTION

The performance standards and non-compliance penalties which govern special reclamation-bond forfeiture projects are in Chapter 22A, Article 3, of the Code of West Virginia and subsequent rules and regulations. The following performance standards are of a general nature and do not represent all the performance standards applicable to a special reclamation-bond forfeiture project. However, some or all of these standards will pertain to each project.

LIFE OF CONTRACT

The purchase order contract becomes effective on the starting date as specified in the notice to proceed as issued by the Department of Environmental Protection. This contract extends for a period of one (1) year and may be renewed until such "reasonable time" thereafter as is necessary to complete the payment therefore. A responsible Contractor's Agent shall be on the site at all working times who demonstrates a knowledge of mined land reclamation, contract requirements and responds to DEP (owner) inspections.

WORK PERFORMANCE PERIOD

The work performance period is a defined portion of the contract in which all items shall be completed. The work performance period is to be performed within 365 calendar days. Extensions may be granted based upon contractor's performance, weather conditions and site-specific site conditions.

NOTICE TO PROCEED

A notice to proceed shall be issued to the Contractor by the project contact person for the Department of Environmental Protection. Actual construction may only begin after a Notice to Proceed is given and as specified. Such notice shall specify the starting date of the Purchase Order, the work performance period, and the completion date of the work performance period.

PRE-CONSTRUCTION CONFERENCE

The Contractor in possession of the awarded purchase order shall schedule a Pre-Construction Conference on the site within ten (10) days after receiving the Notice To Proceed. The Contractor's foreman or the on-the-ground supervisor must be in attendance.

GENERAL SUPERVISION

This contract is under the general supervision of the West Virginia Department of Environmental Protection's contact person for the purpose of contract compliance inspection only. Contractor shall supervise work being conducted at all times. All services rendered by the Engineer/Contact Person consist of professional opinions and recommendations made in accordance with generally accepted engineering practice. Under no circumstances is it the intent of the Engineer/Contact Person to directly control the physical activities of the Contractor or the Contractor's workmen's accomplishment of work on this project.

CONTRACTOR RESPONSIBILITY

The contractor is responsible for compliance with all aspects of this written contract. No changes will be honored without prior approval from the Program Supervisor.

SILENCE OF SPECIFICATIONS

The apparent silence of these Specifications, Supplemental Specifications, plans and Special Provisions as to any detail, or the apparent omission from them of a detailed description concerning any point shall be regarded as meaning that only material and workmanship of acceptable quality are to be used.

BUYER CB-23	PAGE 026	REQ. OR PO NO. DEP13568
SPENDING UNIT WEST VIRGINIA DEPARTMENT OF ENVIRONMENTAL PROTECTION/SPECIAL RECLAMATION		

WV-36a STATE OF WEST VIRGINIA
 Rev. 1/29/02 PURCHASING CONTINUATION SHEET
 VENDOR:

LAWS TO BE OBSERVED

The Contractor shall keep fully informed of all Federal and State laws, all local laws, ordinances, and regulations and all orders and decrees of bodies or tribunals having any jurisdiction or authority, which in any manner affect those engaged or employed on the work, or which in any way affect the conduct of the work. The Contractor shall at all times observe and comply with all such laws, ordinances, regulations, orders and decrees; and shall protect and indemnify the State and its representatives against any claim or liability arising from or based on the violation of any such laws, ordinances, regulations, orders, or decrees, whether by themselves, their subcontractors or their employees.

PERMITS, LICENSES AND TAXES

The Contractor shall procure all permits and licenses, pay all charges, fees, and taxes, and give all notices necessary and incidental to the due and lawful prosecution of the work.

CONCURRENT RECLAMATION

Reclamation of this project shall commence at a definite point as defined and shall progress from that point with total reclamation to include backfilling, grading/regrading, and revegetation. Changes may be granted based upon weather or differing site conditions with prior approval.

WATER QUALITY CONTROL

Shall commence with initial start-up of the project and remain in effect for the extent of the backfilling, regrading and revegetation activity. DEP obtains a storm water permit for each project from the Water Resources Division. (General Water Pollution Control Permit WVO115924) The Contractor is responsible for performing the best management practices. Adequate facilities shall be installed, operated and maintained using the best management practices of the U.S. Environmental Protection Agency's Non-Point Source (NPS) Program for sediment control during the active reclamation. The contractor shall take any and all steps necessary to prevent erosion or silting problems from occurring and to minimize pollution or sedimentation of the stream. If any such problems develop, the contractor shall be responsible to take immediate corrective action. No separate payment for this work will be honored. All impounded waters which require removal during reclamation, shall be pumped with appropriate measures taken to prevent erosion from the discharge. The contractor shall be responsible for treatment of said waters to meet pH standards. The water shall be discharged only when the quality meets a pH equivalent to the pH of the receiving stream but not less than 6.0.

DIFFERING SITE CONDITIONS

During the progress of the work, if subsurface or latent physical conditions are encountered at the site differing materially from those indicated in the contract or if unknown physical conditions of an unusual nature, differing materially from those ordinarily encountered and generally recognized as inherent in the work provided by the contract, are encountered at the site, the party discovering such conditions shall promptly notify the other party in writing of the specific differing conditions before they are disturbed and before the affected work is performed.

Upon written notification, the Engineer/Contact Person will investigate the conditions, and if determined that the conditions materially differ and cause an increase or decrease in the cost or time required for the performance of any work under the contract, an adjustment, excluding loss of anticipated profits, will be made and the contract modified in writing accordingly. The Engineer/Contact Person will notify the Contractor of DEP's determination whether or not an adjustment of the contract is warranted.

No contract adjustment which results in a benefit to the Contractor will be allowed unless the Contractor has provided the required written notice.

No contract adjustment will be allowed under this clause for any effects caused on unchanged work.

BUYER CB-23	PAGE 027	REQ. OR PO NO. DEP13568
SPENDING UNIT WEST VIRGINIA DEPARTMENT OF ENVIRONMENTAL PROTECTION/SPECIAL RECLAMATION		

WV-36a STATE OF WEST VIRGINIA
 Rev. 1/29/02 PURCHASING CONTINUATION SHEET
 VENDOR:

HANDLING AND STORAGE OF MATERIALS

Materials which are stored on site, before utilization, shall be stored so as to assure the preservation of their quality and fitness for the work. Stored materials, even though approved before storage, may be inspected again prior to their use in the work. Damaged or deteriorated materials shall be removed and replaced by materials meeting the original specifications.

Aggregate stockpiles shall be made on ground that is denuded of vegetation, hard, and well drained. Removal of aggregate from the stockpile shall be done in a manner which will not result in the inclusion of foreign material into the aggregate. The use of the aggregate will determine if exceptions are permitted.

All materials shall be handled in such a manner as to preserve their quality and fitness for the work.

MAINTENANCE DURING CONSTRUCTION

The contractor shall maintain the work during construction and until the project is accepted. All cost of maintenance work during construction and before the project is accepted shall be included in the unit or lump sum prices on the various pay items.

FINAL INSPECTION

A final inspection meeting by the Department of Environmental Protection's Specialist and the contractor is required for the construction phase and prior to demobilization.

ACREAGE QUANTITIES

The acreage quantities in this contract are for bidding purpose and are set (definite) number for the project area as specified at the pre-bid showing. Only surveyed acreage's through figures the Contractor and/or the State develops will be honored to alter these acreage numbers.

PAYMENT

Invoices must be submitted on prescribed Department of Environmental Protection, Special Reclamation Program forms and include verification. Certified contractor payrolls for operators directly involved in this project and a current workers compensation certificate must accompany each invoice for payment. Verification of wage rates may include employee interviews. Invoices shall be signed in blue ink so that it is easy to verify that document is an original.

MOBILIZATION/DEMOLIBILIZATION shall be invoiced at fifty percent (50%) with the first invoice and the last 50% invoiced after demobilization and acceptance of the road abandonment or final invoice. Demobilization must have written approval.

SPILL CONTAINMENT AREA shall not exceed \$1,000.00 and will be payable in two payments. The first fifty percent (50%) payable with the first invoice and the remainder payable when all fuel tanks, containers and etc., are removed from the site.

Lump sum items shall be percentage payments based on work completed at time of invoice and paid upon acceptance by the Department of Environmental Protection.

Unit items shall be invoiced by specified units completed and accepted by the DEP.

ROAD ABANDONMENT shall be included in the final construction invoice.

FAILURE TO COMPLETE ON TIME AND LIQUIDATED DAMAGES

Time is an essential element of the Contract and it is important that the work be completed within the time specified. The cost to the Department of the administration of the Contract, including engineering, inspection and supervision, will increase as the time required to complete the work is increased.

The work performance period as specified in the contract's Notice to Proceed shall be complied with or result in liquidated damages. Such damages shall be assessed at an amount of two hundred and fifty dollars

BUYER CB-23	PAGE 028	REQ. OR PO NO. DEP13568
SPENDING UNIT WEST VIRGINIA DEPARTMENT OF ENVIRONMENTAL PROTECTION/SPECIAL RECLAMATION		

WV-36a STATE OF WEST VIRGINIA
 Rev. 1/29/02 PURCHASING CONTINUATION SHEET
 VENDOR:

(\$250.00) per day for each and every day beyond the work performance period as specified in the Notice to Proceed. The total amount of daily charges will be deducted from any moneys due the Contractor, not as a penalty but as liquidated damages.

REVEGETATION AND WARRANTY

The seeding date shall be at the discretion of the contractor once an approved seedbed has been prepared. In all cases a permanent vegetative cover capable of supporting the post-mining land use must be established. A warranty period of one (1) year shall commence upon completion and payment of the revegetation item of the contract. No payment will be made for additional seeding necessary to comply with warranty requirements. The warranty period will be extended for one (1) year from the date of the last augmented seeding done by the contractor. The performance bond and labor and materials bond shall remain in effect throughout the warranty period. The Standards for Evaluating Vegetative Cover as presented in Title 38, CSR2, Section 9 of the West Virginia Surface Mining Reclamation Regulations will apply.

Equipment for the retracking/scarification to eliminate rills and gullies shall be mobilized and utilized to produce slopes consistent with the regrading and topsoiling bid item prior to warranty reseeding. No additional payment will be made by DEP for this warranty work.

Water utilized for hydroseeding shall be free of injurious or other toxic substances harmful to plant life. The source of water is subject to the approval of the DEP contact person.

CONTRACT NON-COMPLIANCE

If in the opinion of the Department of Environmental Protection the contract is not in compliance with any line item specification, that portion of the project shall cease until a compliance schedule and understanding is demonstrated in writing and accepted by the Director of Division of Land Restoration.

CONTRACT DELETIONS

Any line item or any portion thereof, may be deleted when determined by the project contact person that such line item, or portion thereof, is deemed unnecessary for the successful reclamation of this project. No claim for loss of anticipated profits will be considered.

CANCELLATION

The performance of work under contract may be terminated by the State in whole, or from time to time in part whenever the State shall determine that such termination is in the best interest of the State. Any such termination shall be effected by delivery to the Contractor of a Notice of Termination specifying the extent to which performance of work under the Contract is terminated and the date upon which such termination becomes effective.

When contracts, or any portion thereof, are terminated before completion of all items of work in the Contract, payment will be made for the actual number of units or items of work completed and accepted at the contract unit price. No claim for loss of anticipated profits will be considered. Reimbursement for organization of the work, when not otherwise included in the Contract, and moving equipment to and from the job will be considered where the volume of work completed and accepted is too small to compensate the Contractor for these expenses under the contract unit prices, the intent being that an equitable settlement will be made with the Contractor.

Termination of the Contract or a portion thereof shall not relieve the Contractor of his responsibilities for the completed work, nor shall it relieve his surety of its obligation for and concerning any just claims arising out of the work performed.

This contract may be cancelled in whole or in part in writing by the Director of Purchasing, without prejudice to any other right or remedy it may have, provided that the contractor is given not less than thirty (30) calendar days written notice, (delivered by certified mail, return receipt requested) of intent to terminate. This contract objective is to comply with the reclamation laws of this state and must be expedient to meet the time requirements for reclamation of revoked surface mine permits.

BUYER CB-23	PAGE 029	REQ. OR PO NO. DEP13568
SPENDING UNIT WEST VIRGINIA DEPARTMENT OF ENVIRONMENTAL PROTECTION/SPECIAL RECLAMATION		

WV-36a STATE OF WEST VIRGINIA
 Rev. 1/29/02 PURCHASING CONTINUATION SHEET
 VENDOR:

S

Attn:

A

Re: Notice to Proceed
 Permit Name: _____
 Permit No. _____
 Purchase Order No.: DEP _____

Dear :

M

The purpose of this letter is to express our appreciation for your work in advance and to recognize a reclamation partnership project. The official starting date for the above mentioned purchase order is . The work performance period must be completed by . The contract life of one year is provided to accomplish all line items and to process all payments within that period.

You must schedule a pre-construction conference on site within ten (10) days after receiving this notice to proceed. It is then mandatory that construction begins within ten (10) days of the pre-construction conference and continues diligently until completion of the project. Please contact this office to schedule the pre-construction conference. The foreman, superintendent, or on-the-ground supervisor must be in attendance at this conference.

Failure to comply with this notice to proceed will cause termination of the contract and forfeiture of your performance bond.

If you have any questions please feel free to contact this office.

L

Sincerely,

E

BUYER CB-23	PAGE 030	REQ. OR PO NO. DEP13568
SPENDING UNIT WEST VIRGINIA DEPARTMENT OF ENVIRONMENTAL PROTECTION/SPECIAL RECLAMATION		

WV-36a STATE OF WEST VIRGINIA
Rev. 1/29/02 PURCHASING CONTINUATION SHEET
VENDOR:

General Requirements

Project Construction Sign

Work Required

The work to be performed under this Section consists of providing all labor, material and equipment necessary to install a project sign as indicated on the detail included herein and as specified herein.

Materials

- (a) Paint. Paint for the project sign shall be one (1) coat Exterior-Grade Wood Primer- Sealer, and two (2) coats Exterior-Grade Enamel by Glidden or equivalent.
- (b) Wood. Sign face shall be ¾" X 4' X 8' Marine Exterior plywood, and posts and cross braces shall be treated.
- (c) Hardware. All hardware shall be manufactured from good, commercial-quality material and be rust resistant such as galvanized coated.

Execution

- (a) Project Sign. The signboard shall be cut to the dimensions shown on the details herein. The sign shall be painted with one (1) coat of primer and two (2) coats of white enamel. All exterior cut edges shall be smooth sanded prior to painting. All edges shall be double primed. The letters, border and strips shall be painted as shown on the detail drawing.

The Contractor shall bolt the sign to posts and provide required cross bracing. The posts and sign shall be erected and posts set in gravel base, as shown on the drawings. One (1) sign is required and is to be located at the direction of WVDEP.

- (b) Payment. Payment for the work which shall include installation of the project sign shall be incidental to the lump sum bid item for "Mobilization/Demobilization"

Note: No construction work shall commence prior to the project sign being installed.



STATE OF WEST VIRGINIA
DEPARTMENT OF ENVIRONMENTAL PROTECTION

Division of Land Restoration
Office of Special Reclamation

Joe Manchin, III
Governor



Stephanie Timmermeyer,
Cabinet Secretary



Ken Ellison,
Director

Project Cost: \$XXX,XXX.00
Funding provided by the Special Reclamation Coal Tax paid by WV Coal Mine Companies

Permit Name
Permit Number
Contractor: Joe Smith Contracting
Project Start Date: 01/01/01

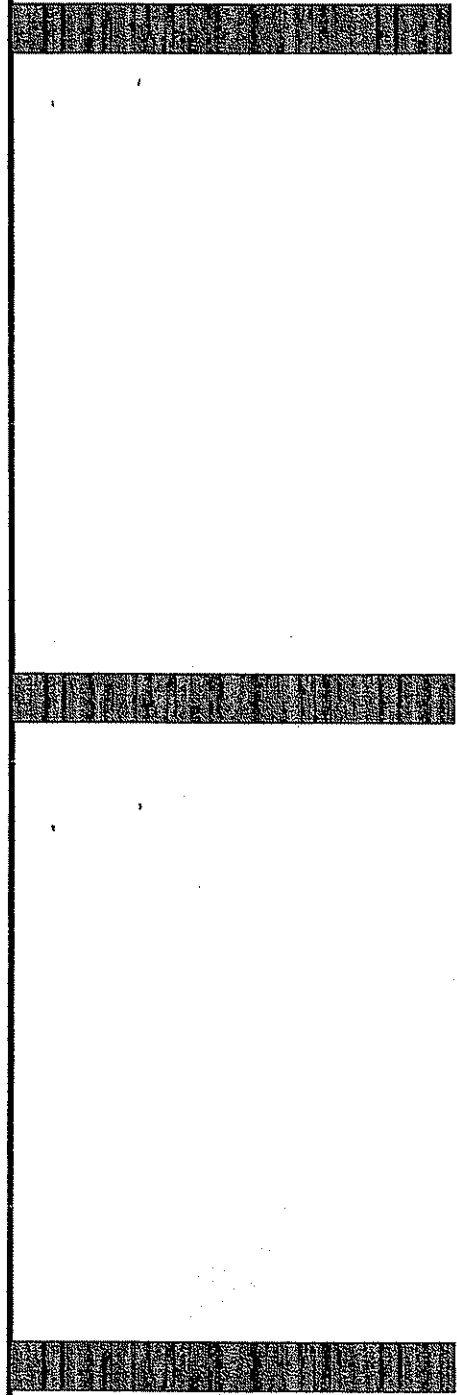

77 1/4"

27 3/4"

STATE OF WEST VIRGINIA
DEPARTMENT OF ENVIRONMENTAL PROTECTION

Division of Land Restoration
Office of Special Reclamation

Project Cost: \$XXX,XXX.00
Funding provided by the Special Reclamation Coal Tax paid by WV Coal Mine Companies

Permit Name
Permit Number

Project Start Date: 01/01/01

Contractor: Joe Smith Contracting

CB-23

PAGE 032 DEP13568

17 1/4"

1 1/2"

1 1/8"

15 3/4"

Joe Manchin, III
Governor

7 7/8"



Stephanie Timmermeyer,
Cabinet Secretary

7 7/8"



3"

Ken Ellison,
Director

8 5/8"

18"

2 1/4"

73 7/8"

36"

36"

48"

6"

6"

96"



STATE OF WEST VIRGINIA
DEPARTMENT OF ENVIRONMENTAL PROTECTION

Division of Land Restoration
Office of Special Reclamation

Joe Manchin, III
Governor

Project Cost: \$XXX,XXX.00
Funding provided by the Special Reclamation Coal Tax paid by WV Coal Mine Companies



Stephanie Timmermeyer,
Cabinet Secretary



Ken Ellison,
Director

Permit Name	Project Start Date: 01/01/01
Permit Number	
Contractor: Joe Smith Contracting	



81 3/8"

7 7/8"

9 3/8"

5 1/4"

48"

6"	2 1/4"	1 1/4"	2 1/4"	3 3/4"	2 1/4"	1 1/4"	2 1/4"	3 3/4"	1 1/4"	4 7/8"	2 1/4"	1 1/2"	2 1/4"	4 7/8"	3 3/4"
<p>STATE OF WEST VIRGINIA</p> <p>DEPARTMENT OF ENVIRONMENTAL PROTECTION</p> <p>Division of Land Restoration</p> <p>Office of Special Reclamation</p> <p>Project Cost: \$XXX,XXX.00</p> <p>Funding provided by the Special Reclamation Coal Tax paid by WV Coal Mine Companies</p> <p>Permit Name</p> <p>Permit Number</p> <p>Contractor: Joe Smith Contracting</p> <p>Project Start Date: 01/01/01</p>															
17 1/2"	1 1/2"	3/4"	1 1/4"	9 1/2"	1"	3/4"	1"	8"	1"	3/4"	1"	3/4"	1"	3 3/4"	
 <p>Joe Manchin, III Governor</p>  <p>Stephanie Timmermeyer, Cabinet Secretary</p>  <p>Ken Ellison, Director</p>															

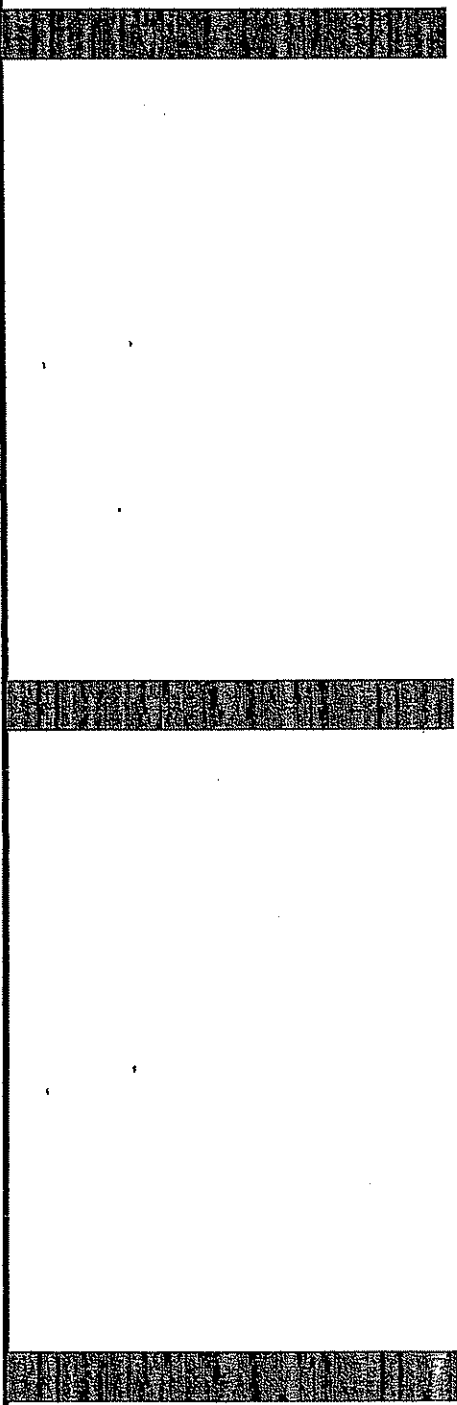

Notes:

1. Sign Board to be 3/4" by 4' X 8' Marine Plywood
2. Sign Board Color is to be White and Letter Colors are to be Dark Green
3. 2" X 4" Treated Cross Brace Let into Posts
4. Mount sign to Posts using 3/8" X 5" Galvanized Carriage Bolts
5. Posts are to be Treated 4" X 4" X 12'
6. Location determined WVDEP

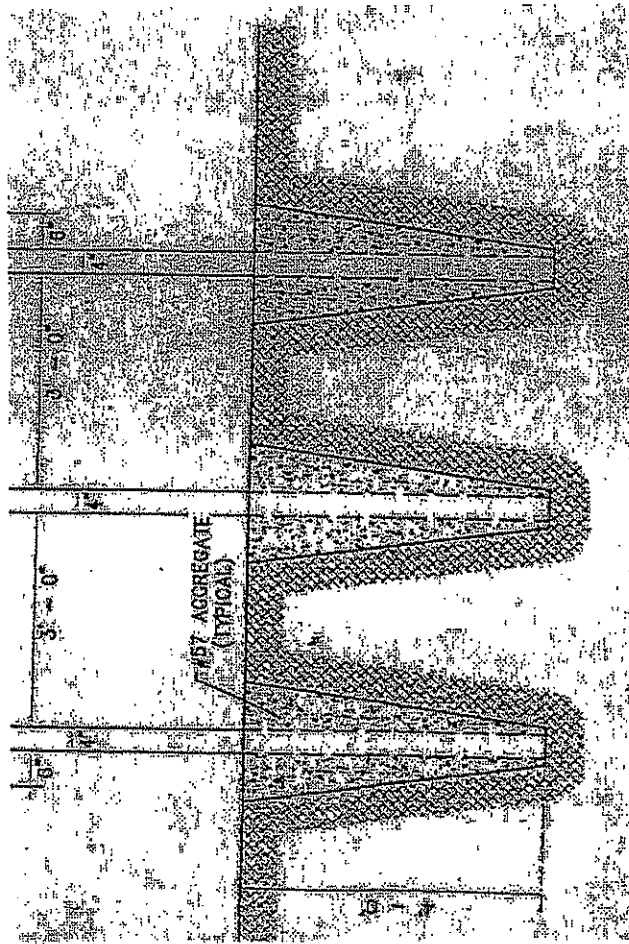
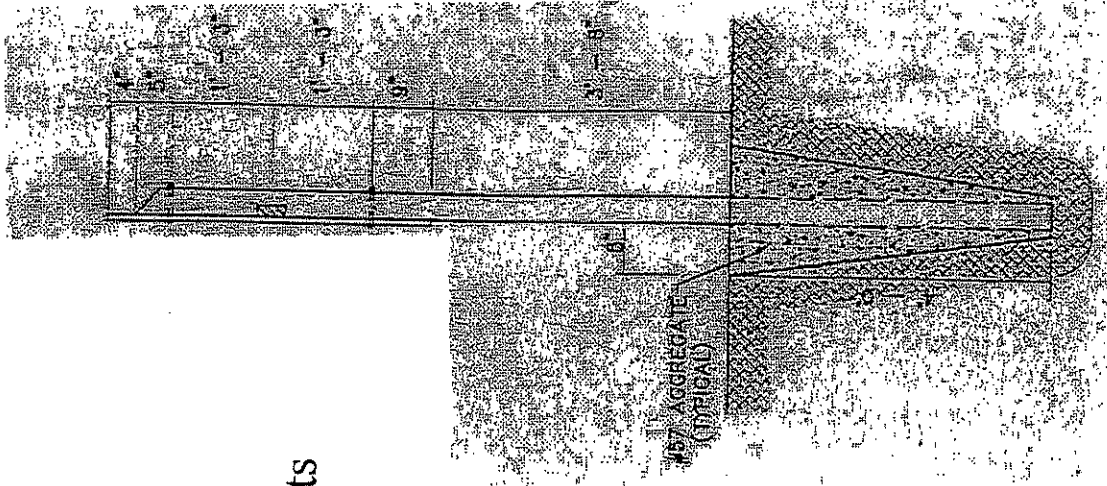

BUYER **ARCADIA** **36** DEP 1356B
CB-23
West Virginia D. E. P.
Special Reclamation



State of West Virginia
Department of Environmental Protection
Special Reclamation
Daugherty Coal Co. 65-77
Current Conditions

BUYER: R-2-37, Rec or PD No.
CB-23 DEP 13568

West Virginia D. E. P.
Special Reclamation

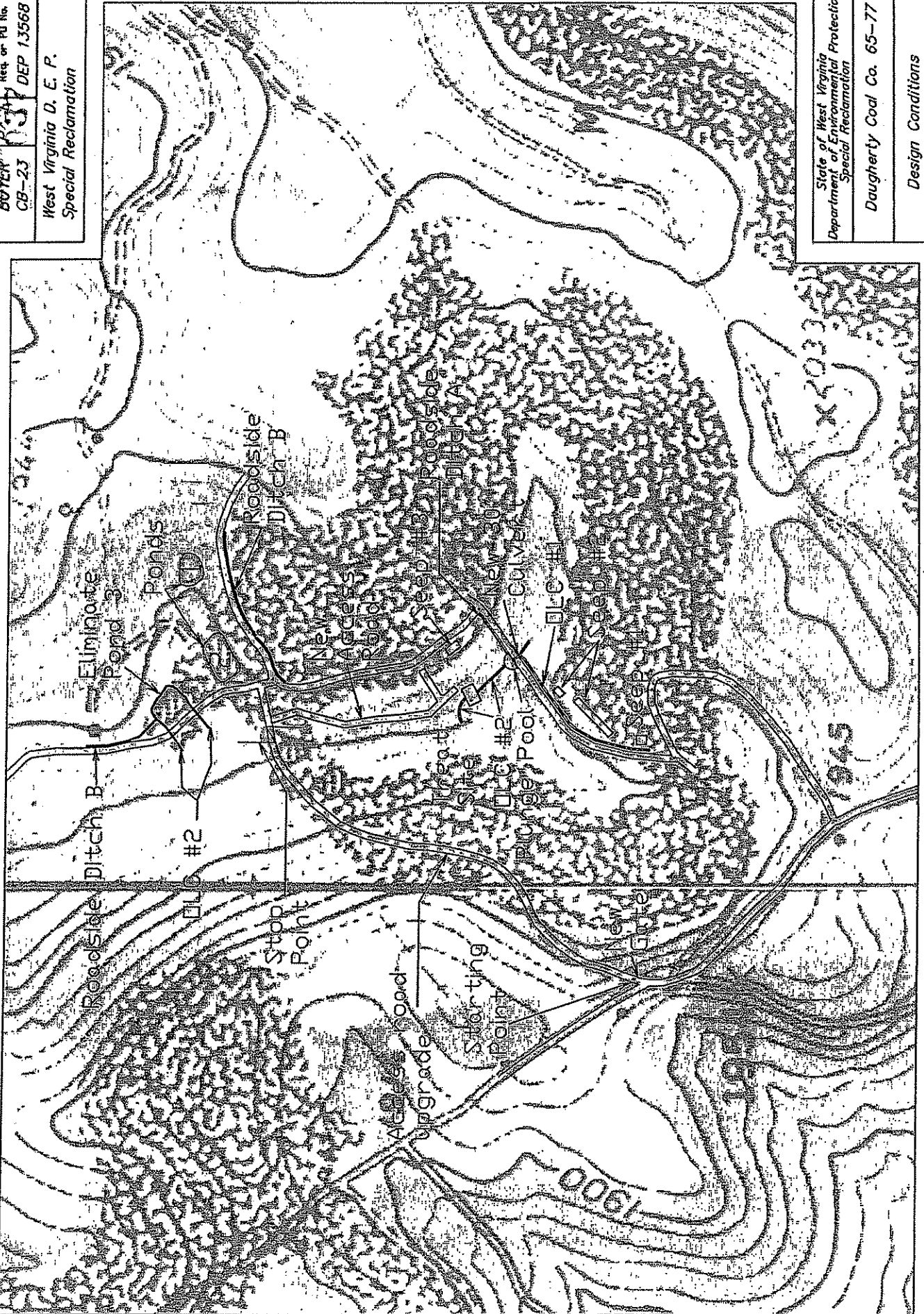

State of West Virginia
Department of Environmental Protection
Special Reclamation

Daugherty Coal Co. 65-77

Design Conditions

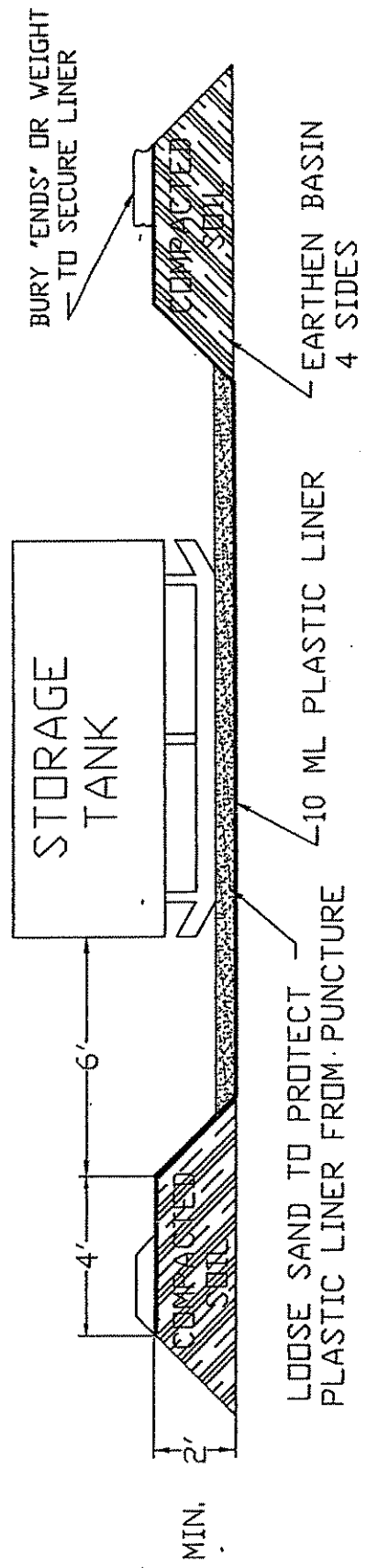

SELECTED HEIGHT OF EARTHEN BERM IS TO BE A TWO (2') FOOT MINIMUM OR ONE HUNDRED TEN PERCENT (110%) OF THE CAPACITY OF THE TANK(S) TOTAL VOLUME WITHIN THE BERM. A SIX (6") INCH FREEBOARD MUST BE INCLUDED.

NOTE: A TWO INCH (2") WATER REMOVAL DRAIN SHALL BE LOCATED AT THE LOWEST POINT IN THE BOTTOM OF THE CONTAINMENT VOLUME. IT SHALL CONNECT TO A NORMALLY CLOSED VALVE OUTSIDE THE DIKE. THE VALVE SHALL BE MANUALLY OPERATED AND PROTECTED FROM UNAUTHORIZED OPERATION. RAINWATER CONTAINED WITHIN THIS DIKE SHALL BE EXAMINED PRIOR TO RELEASE TO ENSURE THAT HARMFUL QUANTITIES OF FUELS AND LUBRICANTS ARE NOT DISCHARGED.

ALTERNATE METHODS OF WATER REMOVAL WILL BE CONSIDERED FOR APPROVAL.

BUYER
CB-23



Req. or PU No.
DEP 13568

ACCESS ROAD UPGRADE

3" MIN, 1 1/2 CRUSHER RUN
(CHOKE OFF SURFACE)

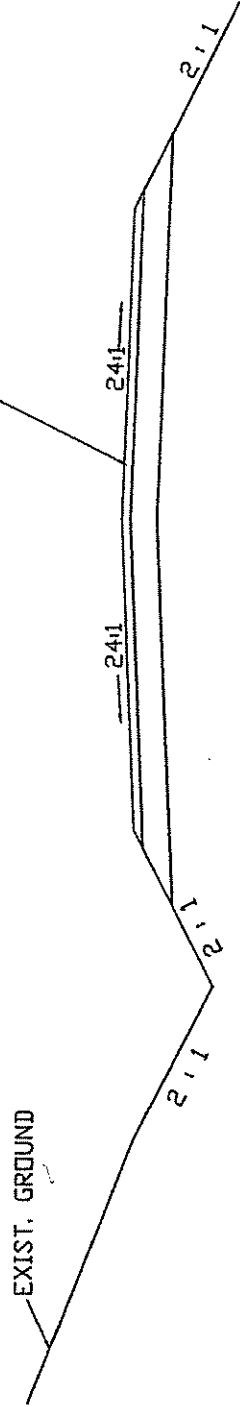

TYPICAL SECTION

State of West Virginia
Department of Environmental Protection
Special Reclamation

Daugherty Coal Co. 65-77

Access Road Upgrade

NEW ACCESS ROAD

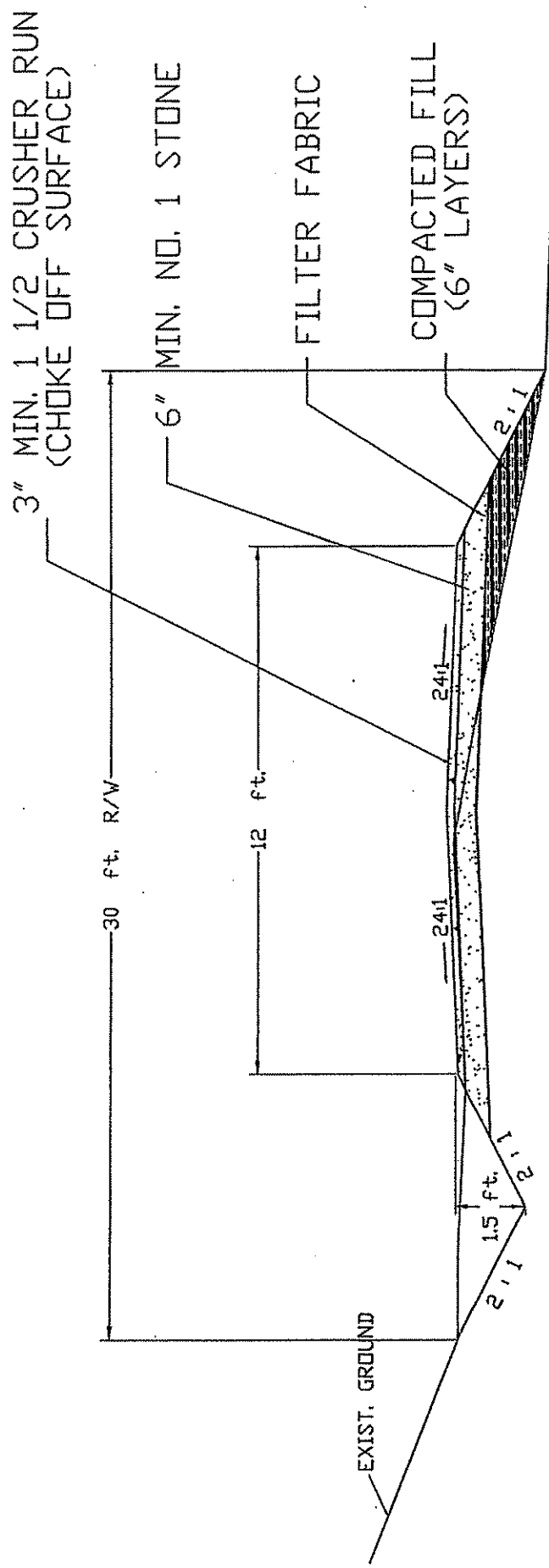

TYPICAL SECTION

BUYER CB-23
Rep. or PD No. DEP 13568

TRUCK TURN-AROUND DETAIL

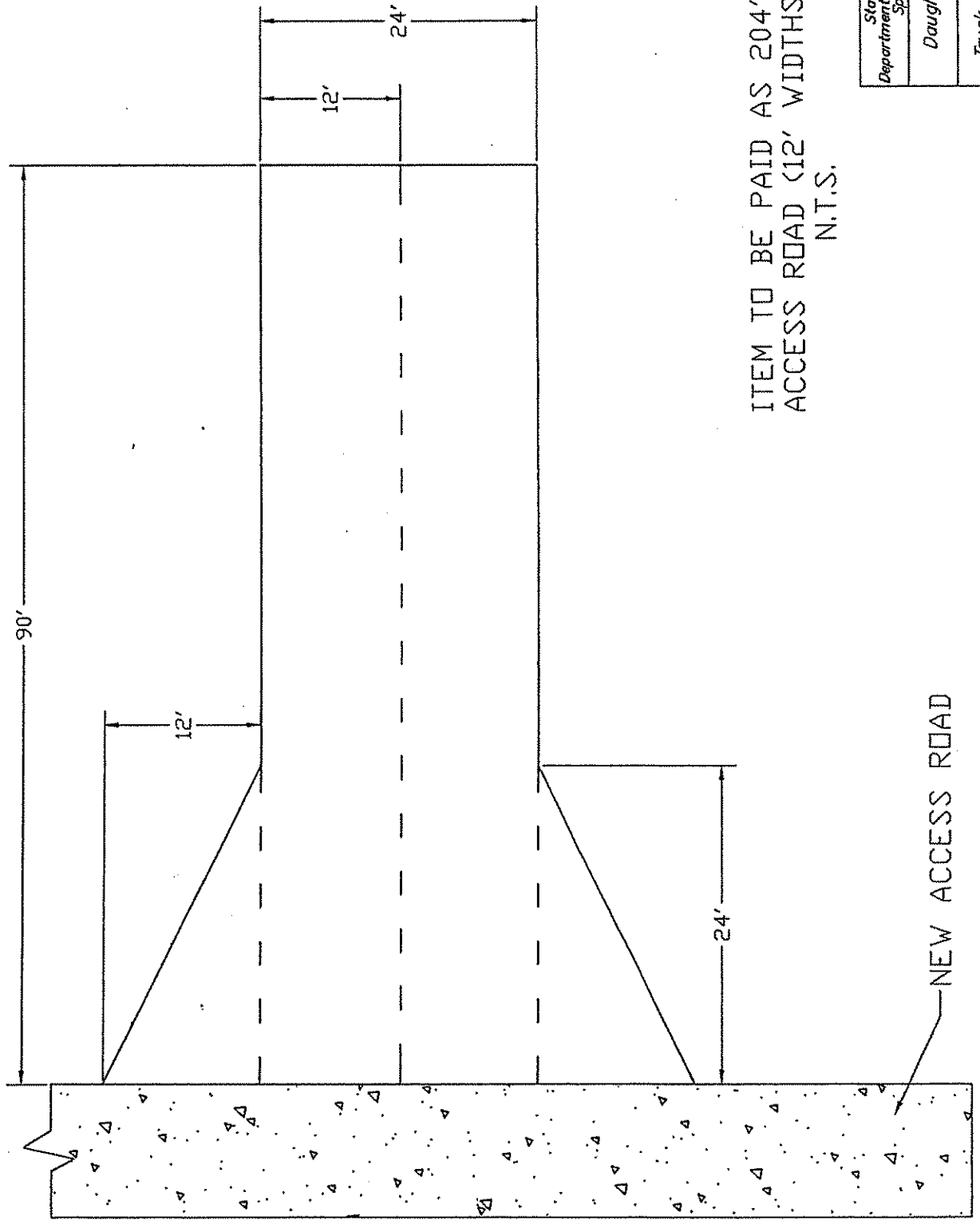

ITEM TO BE PAID AS 204' OF NEW ACCESS ROAD (12' WIDTHS).
N.T.S.

State of West Virginia
Department of Environmental Protection
Special Reclamation
Daugherty Coal Co. 65-77
Truck Turn-Around Detail

PLUNGE POOL

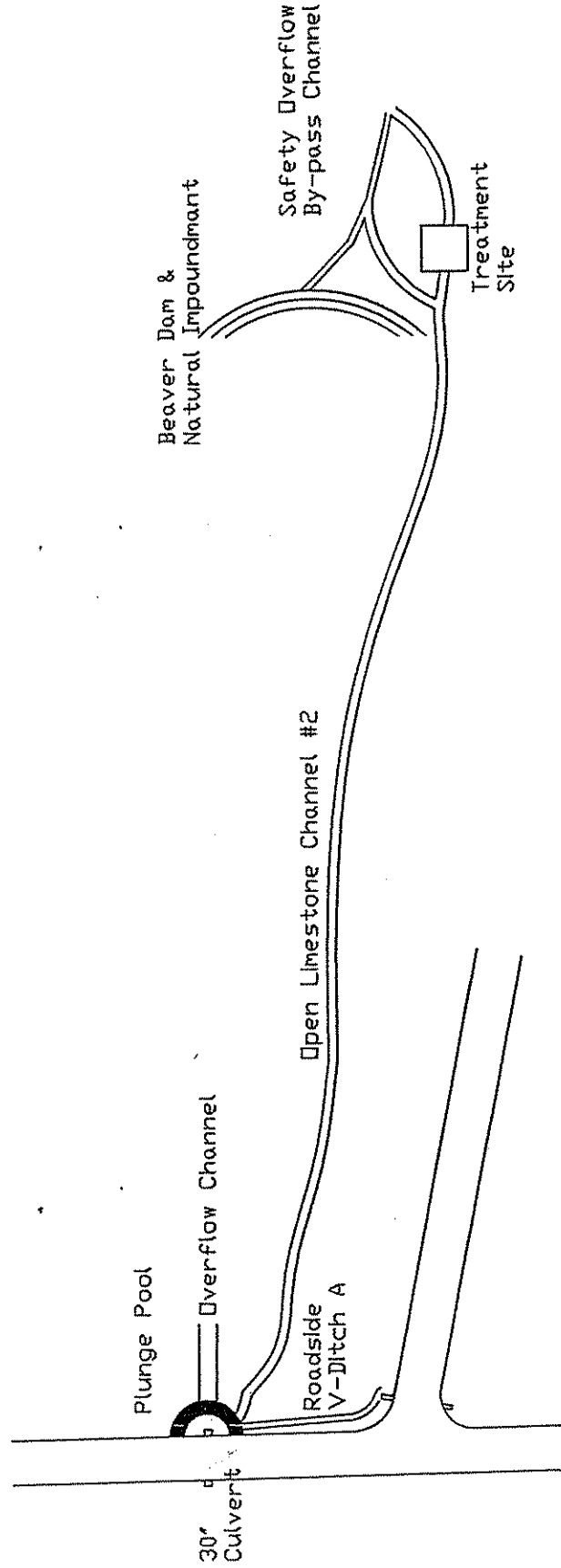

Open Limestone Channel #2 will have a slope a 1% grade from the Plunge Pool to the Treatment Site. There will be a safety overflow, by-pass channel prior to the treatment building. The existing natural flow path and the new V-ditch will be combined into one channel after the building.

The overflow channel is located higher in elevation than the DLC #2 so that water will flow to the building first. The intent of the overflow channel is to allow a large storm volume to exit the Plunge Pool without eroding away any rock or soil material.

Roadside V-Ditch A will be relocated along the access road. This will allow all water to enter the Plunge pool before entering the channels.

PLUNGE POOL CHANNELS

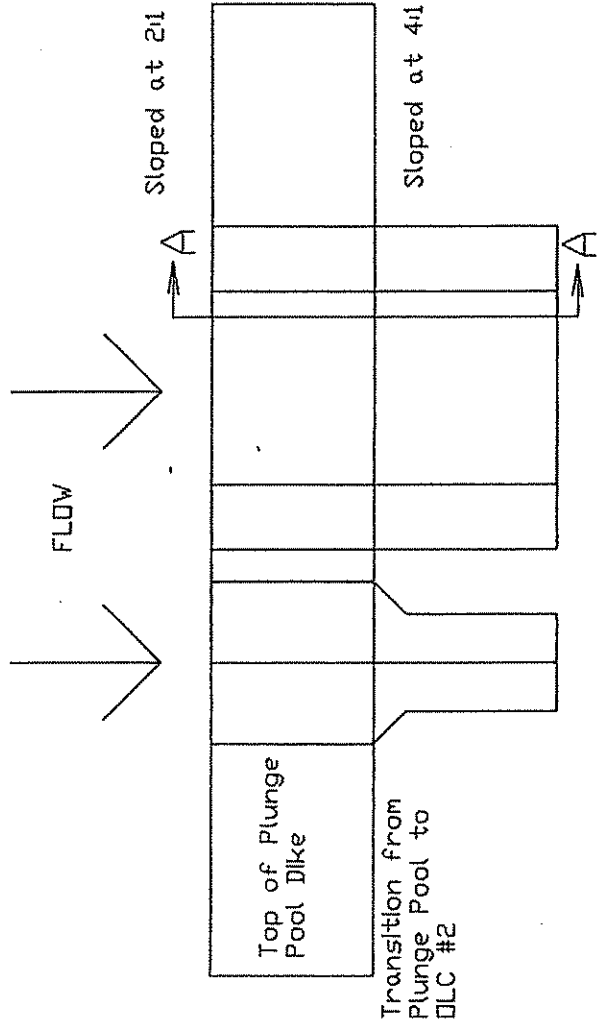

TOP VIEW

The Open Limestone Channel #2 will be located below the High Flow Exit Channel. This is to allow the flow to enter the Exit Channel. This configuration will force the DLC #2 to be 2.5 feet in depth and a top opening of 5 feet. The dimensions will revert back to the detail specs. as soon as the channel passes through the Plunge Pool structure. The Plunge Pool structure may be constructed from compacted earth covered with fabric and riprap stone.

The High Flow Exit Channel will have a slope of 4H:1V (Horizontal to Vertical) on the outflow. This channel will be constructed of standard riprap. The inner slope will be 2H:1V. This pay item will include the compacted earth, filter fabric, all rock for the High Flow Exit Channel, and the rock for the DLC#2 until the profile returns to the specs. for DLC#2. This item is lump sum.

Open Limestone Channel #2 High Flow Exit Channel

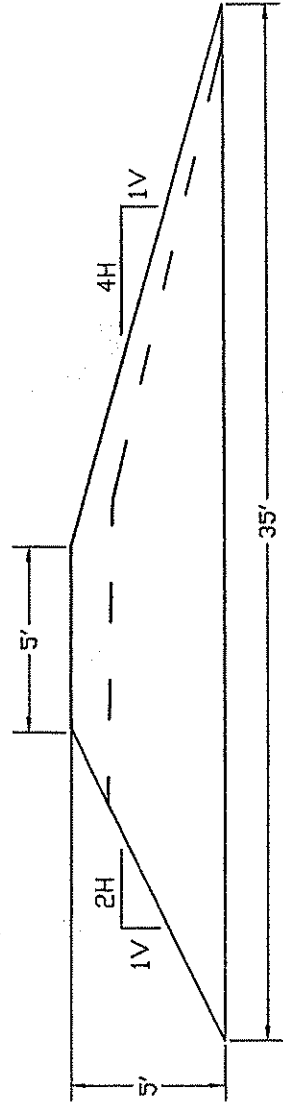

END VIEW

SECTION A-A

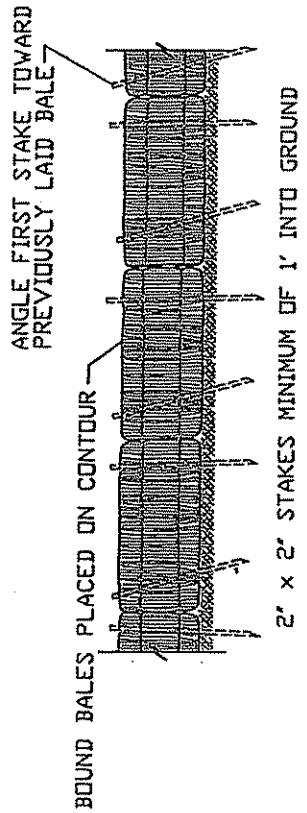

ANCHORING DETAIL

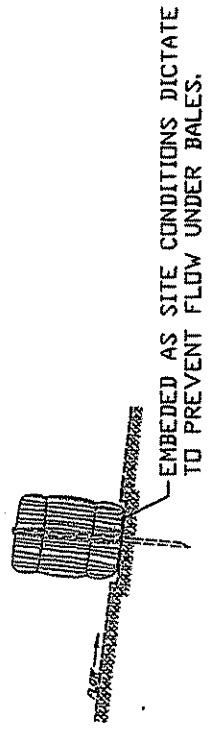

END VIEW

SEDIMENT CONTROL DETAIL

NTS

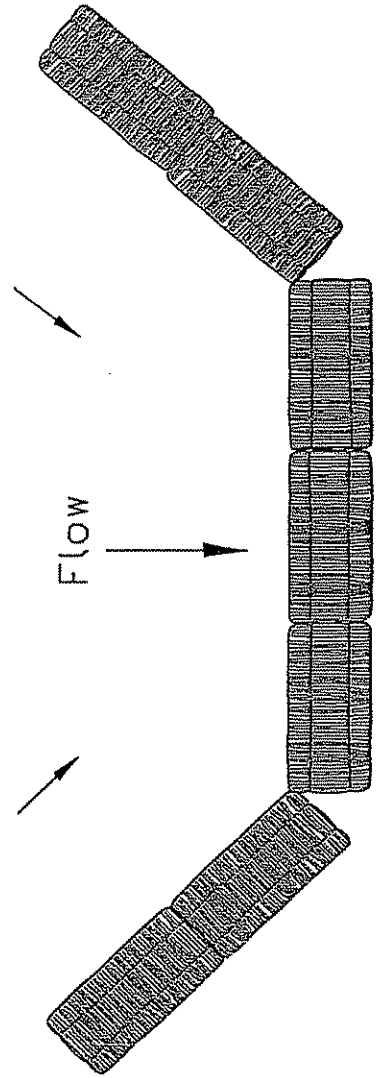

DESIGN TO FIT SITE CONDITIONS

SEDIMENT BARRIER
TOP VIEW

SEEP COLLECTOR #1

4" SDR35 PIPE TO EXTEND ABOVE GROUND AS CLEAN-OUT WITH CAP.

PIPE WITHIN SEEP COLLECTOR SHALL BE SDR35 PERFORATED.

WRAP WITH FILTER FABRIC (NONWOVEN) TYPAR 3401 or EQUIVALENT

TO BE INSTALLED ON COMPETENT MATERIAL AS APPROVED BY THE ON-SITE DEP INSPECTOR.

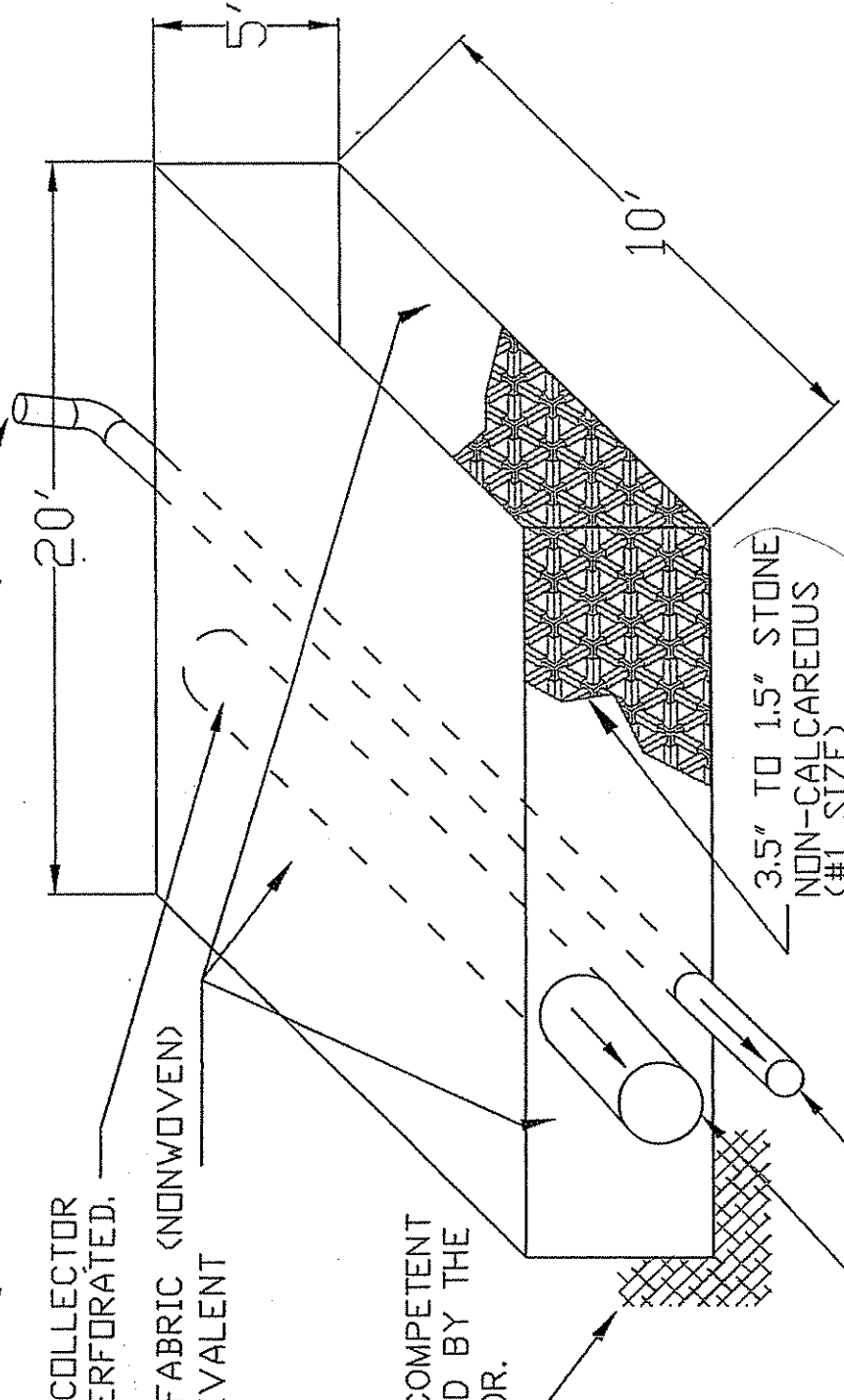

N.T.S.

State of West Virginia
 Department of Environmental Protection
 Special Reclamation

Daugherty Coal Co. 65-77

Seep Collector #1

4" PIPE ON BOTTOM TO DRIVE UNIT.

12" PIPE WITH ANIMAL GUARD TO DLC#1.

SEEP COLLECTOR #2 & #3

WRAP WITH FILTER FABRIC (NONWOVEN)
 TYPAR 3401 or EQUIVALENT

3.5" TO 1.5" STONE
 NON-CALCAREOUS
 (#1 SIZE)

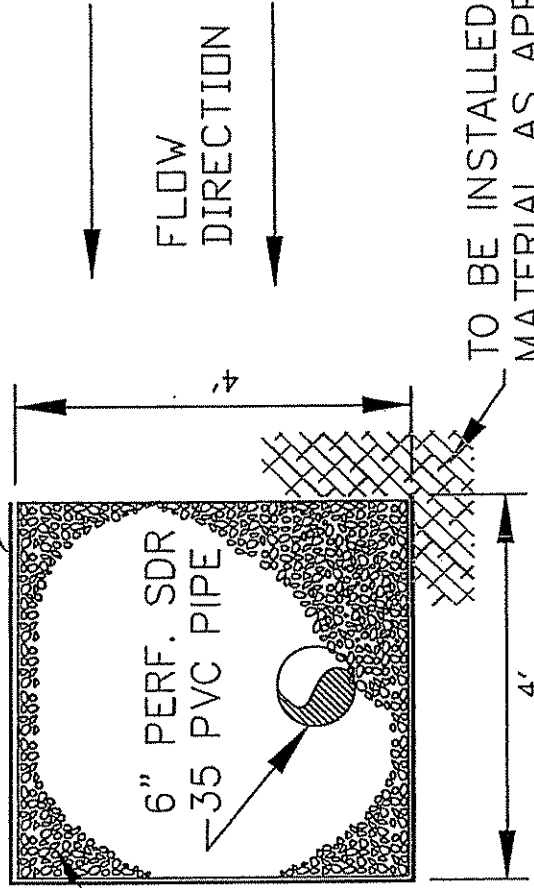

TO BE INSTALLED ON COMPETENT
 MATERIAL AS APPROVED BY THE
 ON-SITE DEP INSPECTOR.

NOTES:

SEEP COLLECTOR #3 SHALL HAVE A 2" PVC PERFORATED LINE ON THE
 BOTTOM. ALSO, THE 2" PVC LINE SHALL EXTEND THROUGH THE SEEP
 COLLECTOR AND EXTEND ABOVE THE GROUND LEVEL AS A CLEAN-OUT.
 AN END CAP SHALL BE SUPPLIED FOR THE 2" PVC LINE.

6" PIPE SHALL DRAIN TO OPEN LIMESTONE DITCH WITH ANIMAL GUARD
 ON END.

N.T.S.

PIPE PERFORATION DETAILS

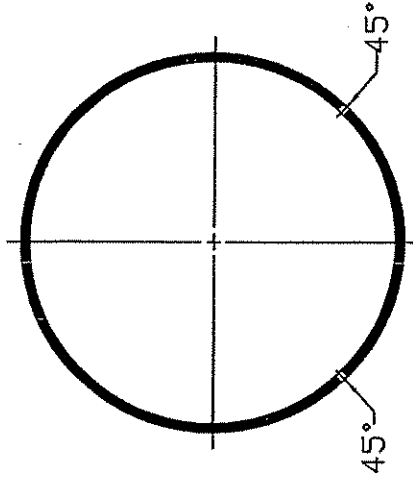

2, 4, & 6 INCH DIAMETER PIPE PERFORATIONS

HOLES SHALL BE 1/2 INCH DIAMETER FOR 2 & 4 INCH PIPE. USE 1 INCH DIAMETER HOLES FOR 6 INCH PIPE.

HOLE SPACING SHALL BE 4 INCHES ON CENTER ALONG THE LENGTH OF PIPE WITHIN SEEP COLLECTOR.

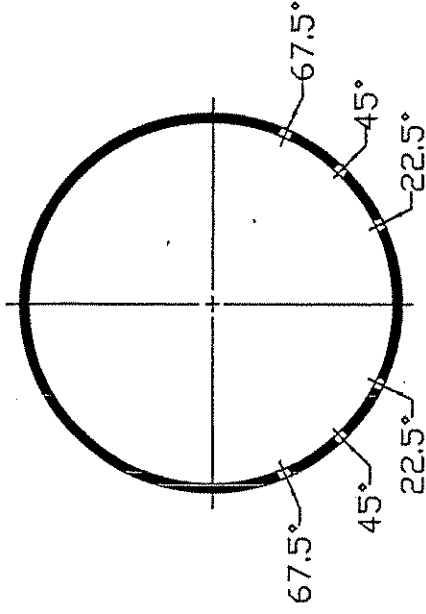

12 INCH DIAMETER PIPE PERFORATIONS

HOLES SHALL BE 1 INCH DIAMETER.

HOLE SPACING SHALL BE 6 INCHES ON CENTER ALONG THE LENGTH OF PIPE WITHIN SEEP COLLECTOR.

ANIMAL GUARD DETAILS

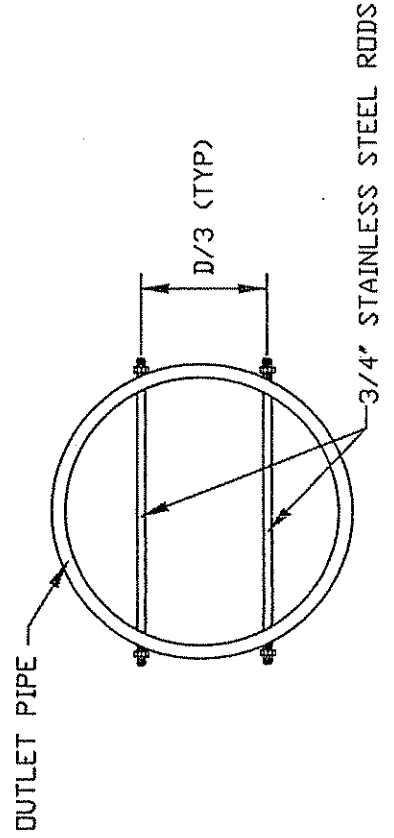

Not To Scale

State of West Virginia
 Department of Environmental Protection
 Special Reclamation

Daugherty Coal Co. 65-77

Pipe Perforation and
 Animal Guard Details

OPEN LIMESTONE CHANNEL #1

850 FOOT LENGTH

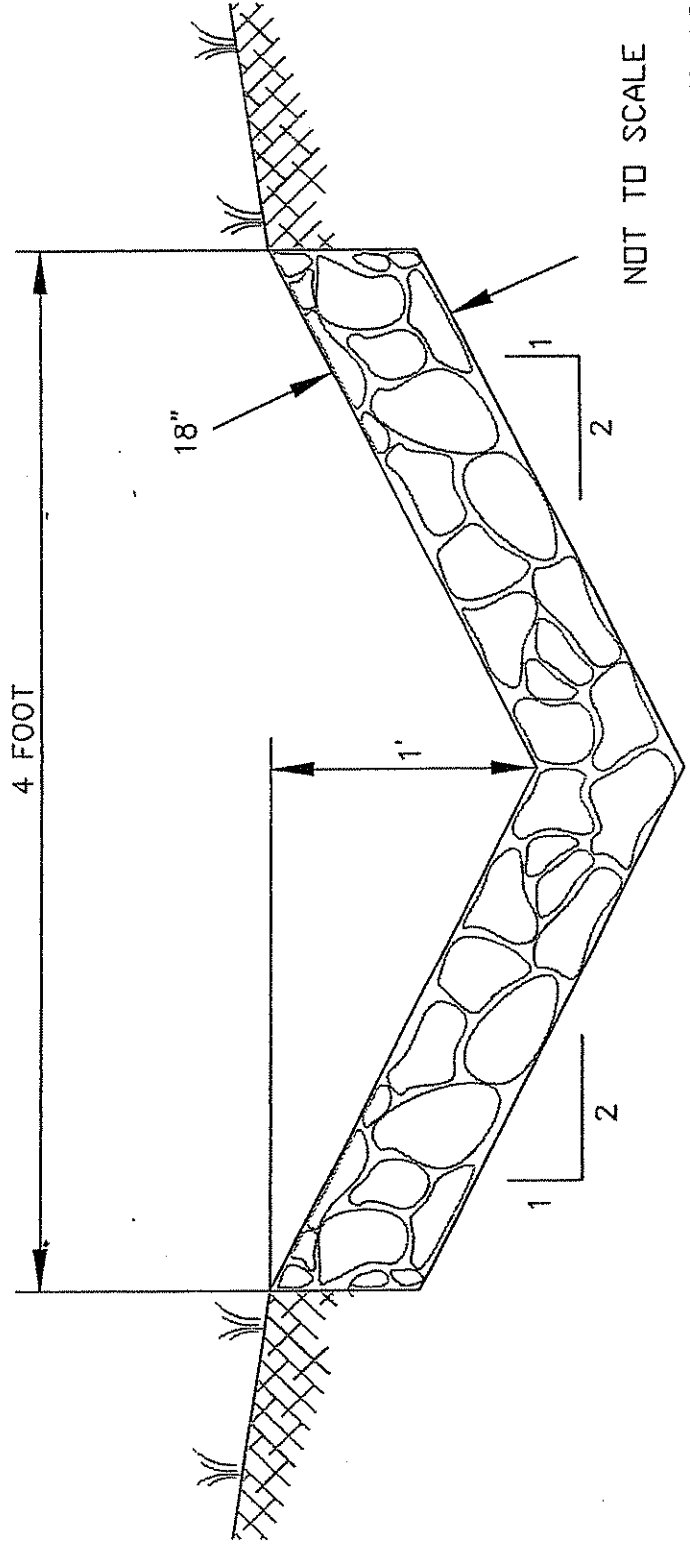

NOT TO SCALE

PAYMENT FOR ACTUAL LENGTH OF
 DITCH CONSTRUCTED.

R-5 RIPRAP (STANDARD)
 UNLESS OTHERWISE NOTED, RIPRAP SHALL BE DURABLE ROCK PLACED IN A 1.5 FOOT
 BLANKET. TWENTY-FIVE (25%) OF THE ROCK WILL BE OF 18 INCHES OR LARGER, THE
 REMAINING SEVENTY-FIVE (75%) SHALL BE WELL GRADED MATERIAL (MINIMUM 3 INCHES
 TO MAXIMUM 15 INCHES) OF SUFFICIENT ROCK SMALL ENOUGH TO FILL THE VOIDS
 BETWEEN THE LARGER ROCK. SHALE SHALL NOT BE USED FOR RIPRAP, IF RIPRAP
 STABILITY IS QUESTIONABLE, DURABILITY SHALL BE DETERMINED BY THE SODIUM
 SULPHATE TEST ASTM C 88/AASHTO T 104-77.

OPEN LIMESTONE CHANNEL #2

900 FOOT LENGTH

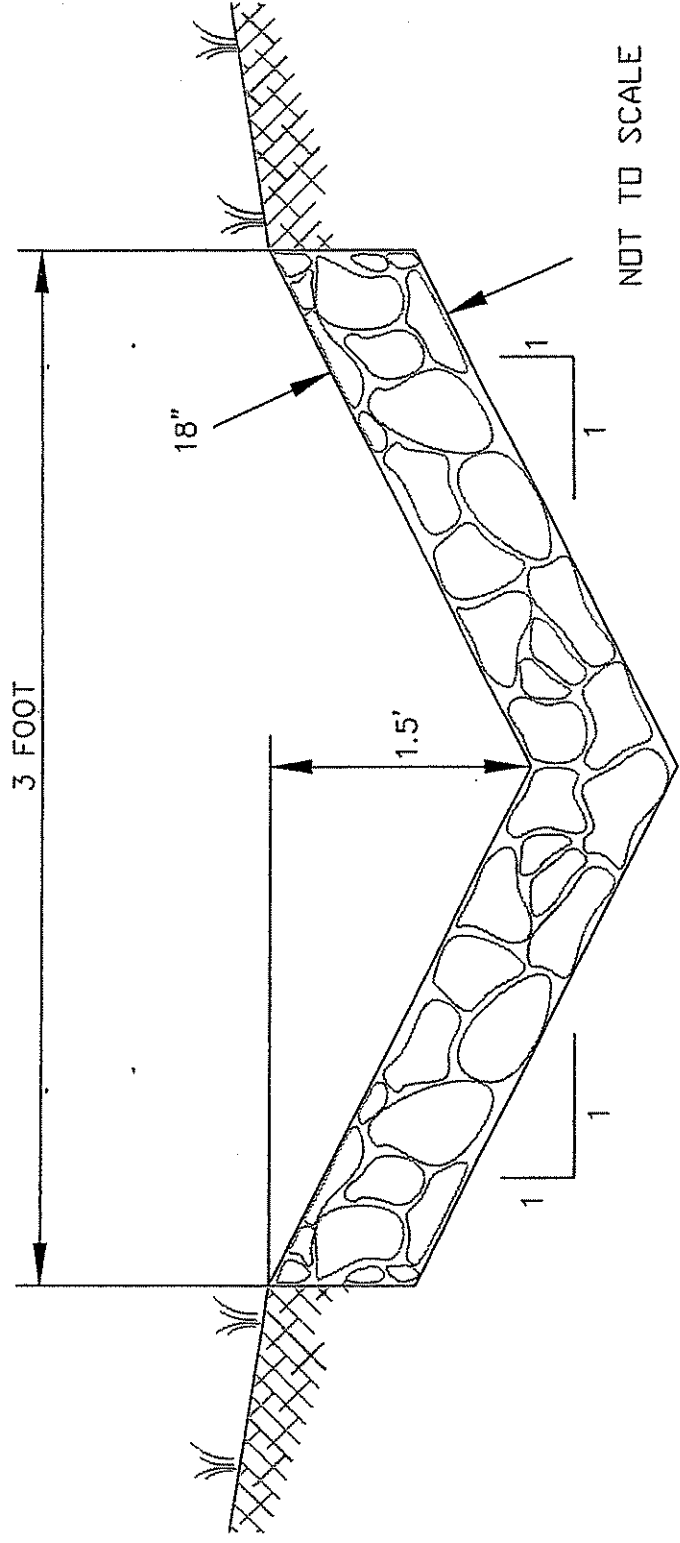

NOT TO SCALE

PAYMENT FOR ACTUAL LENGTH OF DITCH CONSTRUCTED.

R-5 RIPRAP (STANDARD) UNLESS OTHERWISE NOTED, RIPRAP SHALL BE DURABLE ROCK PLACED IN A 1.5 FOOT BLANKET. TWENTY-FIVE (25%) OF THE ROCK WILL BE OF 18 INCHES OR LARGER, THE REMAINING SEVENTY-FIVE (75%) SHALL BE WELL GRADED MATERIAL (MINIMUM 3 INCHES TO MAXIMUM 15 INCHES) OF SUFFICIENT ROCK SMALL ENOUGH TO FILL THE VOIDS BETWEEN THE LARGER ROCK. SHALE SHALL NOT BE USED FOR RIPRAP. IF RIPRAP STABILITY IS QUESTIONABLE, DURABILITY SHALL BE DETERMINED BY THE SODIUM SULPHATE TEST ASTM C 88/AASHTO T 104-77.

ROADSIDE DITCH A
120 FOOT LENGTH

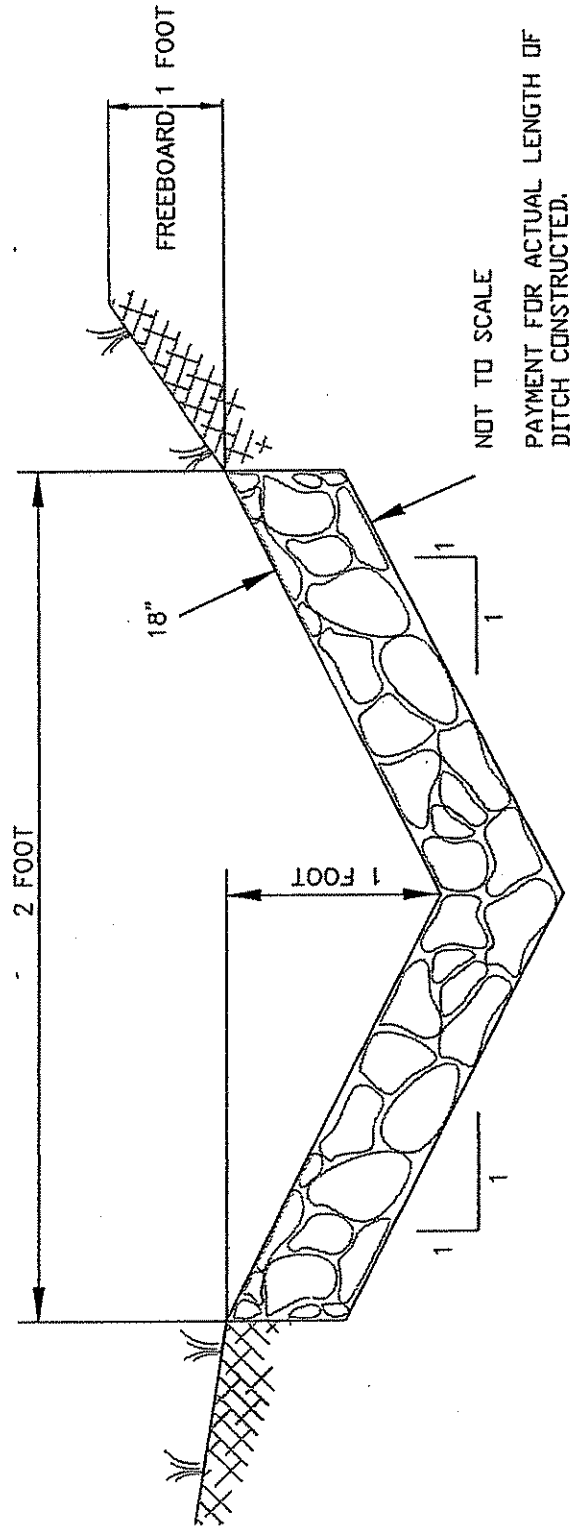

NOT TO SCALE
 PAYMENT FOR ACTUAL LENGTH OF
 DITCH CONSTRUCTED.

R-5 RIPRAP (STANDARD) UNLESS OTHERWISE NOTED, RIPRAP SHALL BE DURABLE ROCK PLACED IN A 1.5 FOOT BLANKET. TWENTY-FIVE (25%) OF THE ROCK WILL BE OF 18 INCHES OR LARGER, THE REMAINING SEVENTY-FIVE (75%) SHALL BE WELL GRADED MATERIAL (MINIMUM 3 INCHES TO MAXIMUM 15 INCHES) OF SUFFICIENT ROCK SMALL ENOUGH TO FILL THE VOIDS BETWEEN THE LARGER ROCK. SHALE SHALL NOT BE USED FOR RIPRAP. IF RIPRAP STABILITY IS QUESTIONABLE, DURABILITY SHALL BE DETERMINED BY THE SODIUM SULPHATE TEST ASTM C 88/AASHTO T 104-77.

ROADSIDE DITCH B
1015 FOOT LENGTH

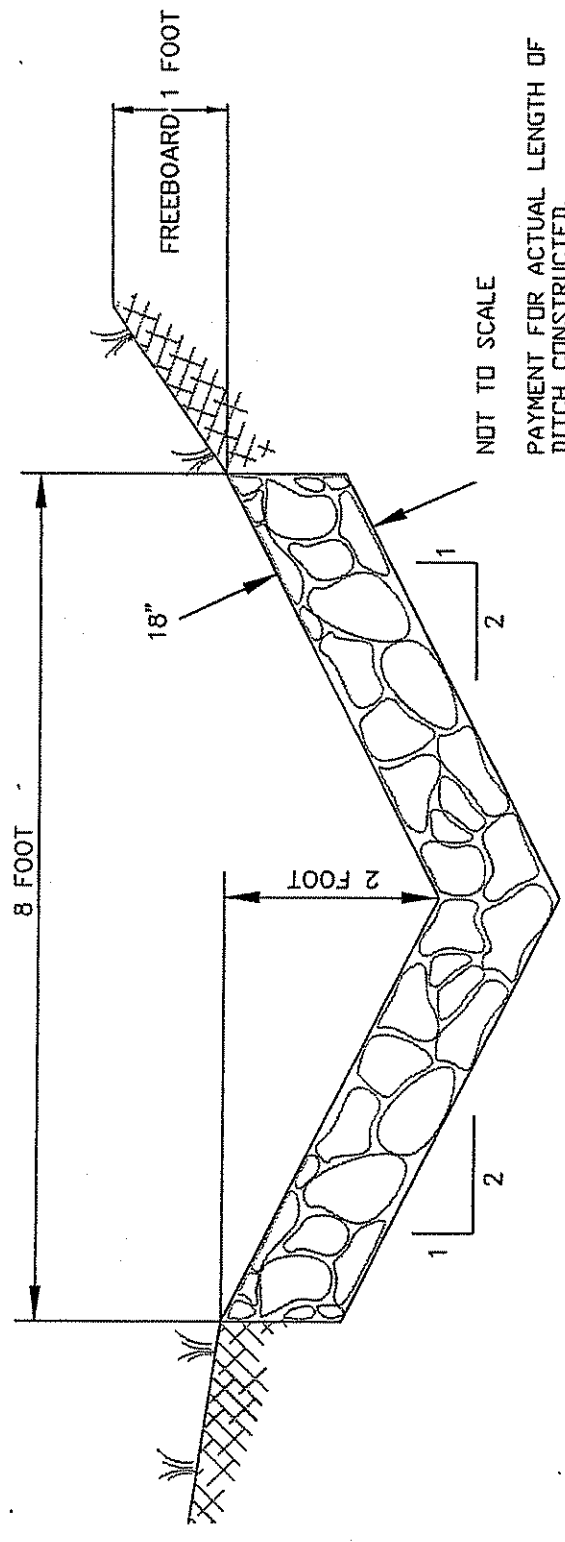

R-5 RIPRAP (STANDARD) UNLESS OTHERWISE NOTED, RIPRAP SHALL BE DURABLE ROCK PLACED IN A 1.5 FOOT BLANKET. TWENTY-FIVE (25%) OF THE ROCK WILL BE OF 18 INCHES OR LARGER, THE REMAINING SEVENTY-FIVE (75%) SHALL BE WELL GRADED MATERIAL (MINIMUM 3 INCHES TO MAXIMUM 15 INCHES) OF SUFFICIENT ROCK SMALL ENOUGH TO FILL THE VOIDS BETWEEN THE LARGER ROCK. SHALE SHALL NOT BE USED FOR RIPRAP. IF RIPRAP STABILITY IS QUESTIONABLE, DURABILITY SHALL BE DETERMINED BY THE SODIUM SULPHATE TEST ASTM C 88/AASHTO T 104-77.

FOUNDATION DETAILS

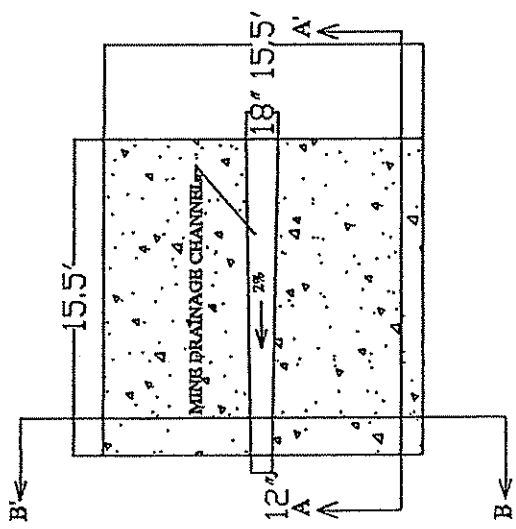

PLAN VIEW

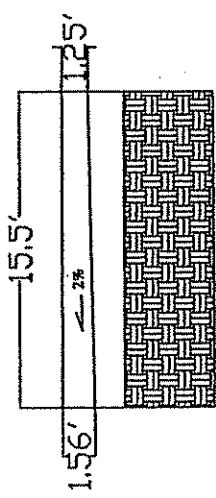

CROSS-SECTION A-A'

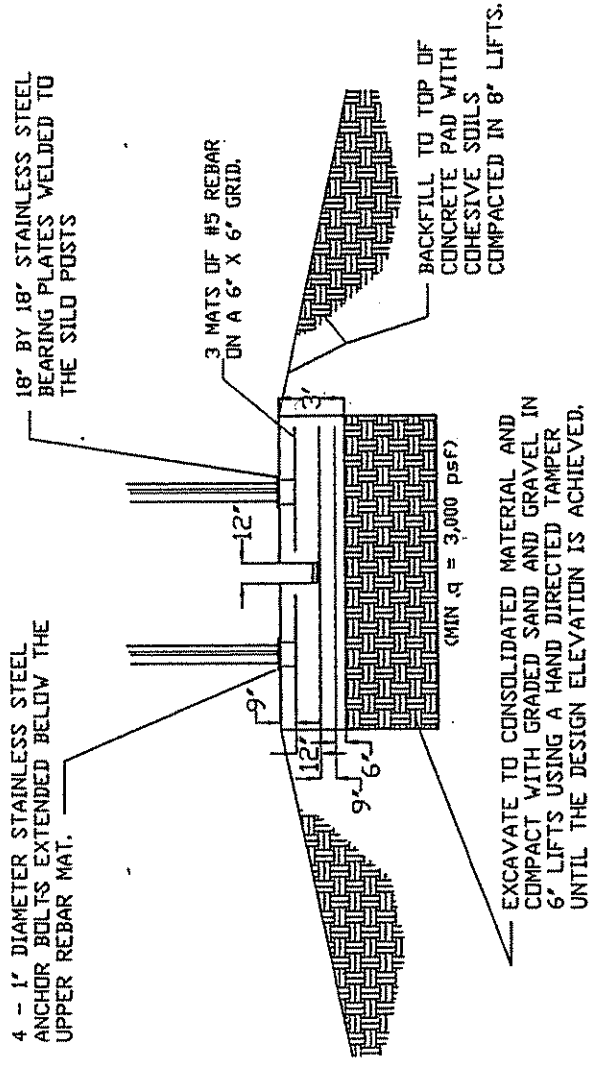

CROSS-SECTION B-B'

MOUNTING PLATE DETAILS

ANCHOR BOLTS ARE SPACED 15' APART MEASURED FROM CENTER TO CENTER.

STAINLESS STEEL PLATES ARE 18' BY 18' BY 1" THICK

HOLE'S ARE 1 1/8" IN DIAMETER.

ANCHOR BOLT SPACING TEMPLATE TO BE PROVIDED BY LIME SILO MANUFACTURER.

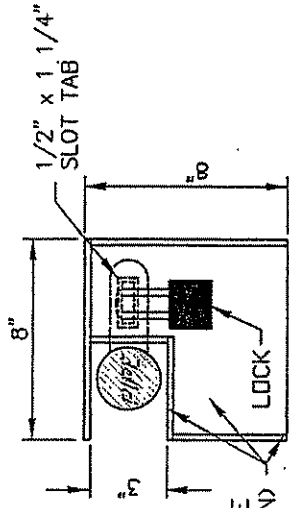
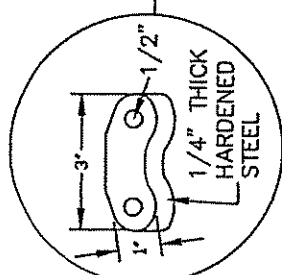
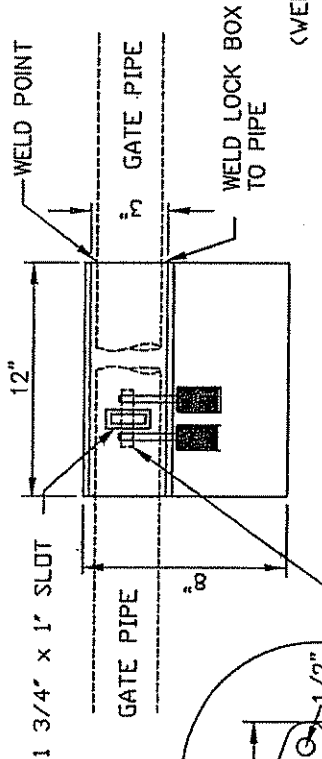

(FRONT) LOCK BOX DETAIL (SIDE)

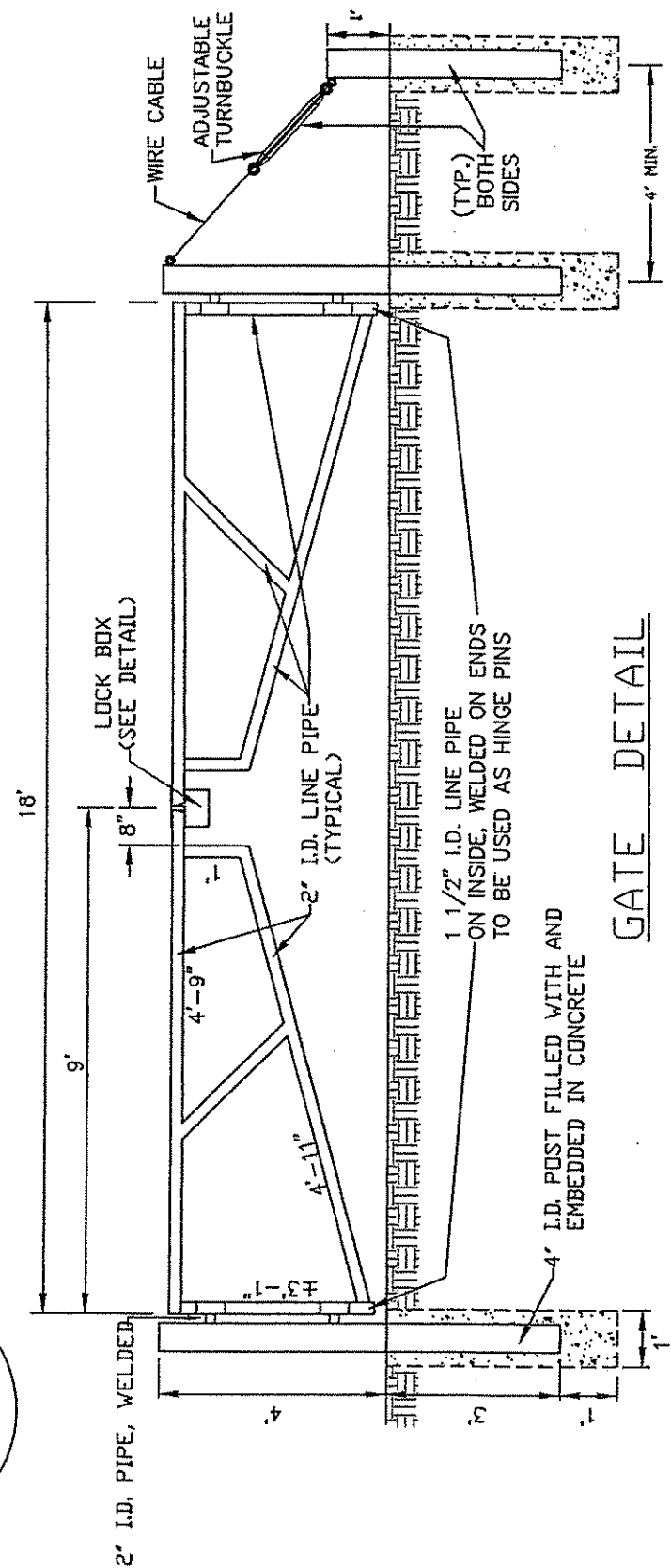

GATE DETAIL (NOT TO SCALE)

NOTES: GREASE FITTINGS SHALL BE INSTALLED AT EACH HINGE POINT.
 ALL ENDS OF PIPE SHALL BE WELDED CLOSED.
 STEEL LINE PIPE SHALL BE 0.188" WALL THICKNESS.

WEST VIRGINIA DEPARTMENT OF
ENVIRONMENTAL PROTECTION
Division of Land Restoration
Office of Special Reclamation

054

Daughterty Coal Company, Inc.

Permit Number(s):	65-77
Project #:	06384
Requisition Number:	DEP13568
County:	Preston

Location: From Masontown (located between Morgantown and Kingwood) on WV State Route 7, travel east on County Route 23 (no sign), turn left onto County Route 52/2 (no sign), turn left onto County Route 52 for 1.0 mile. The site is on the right.

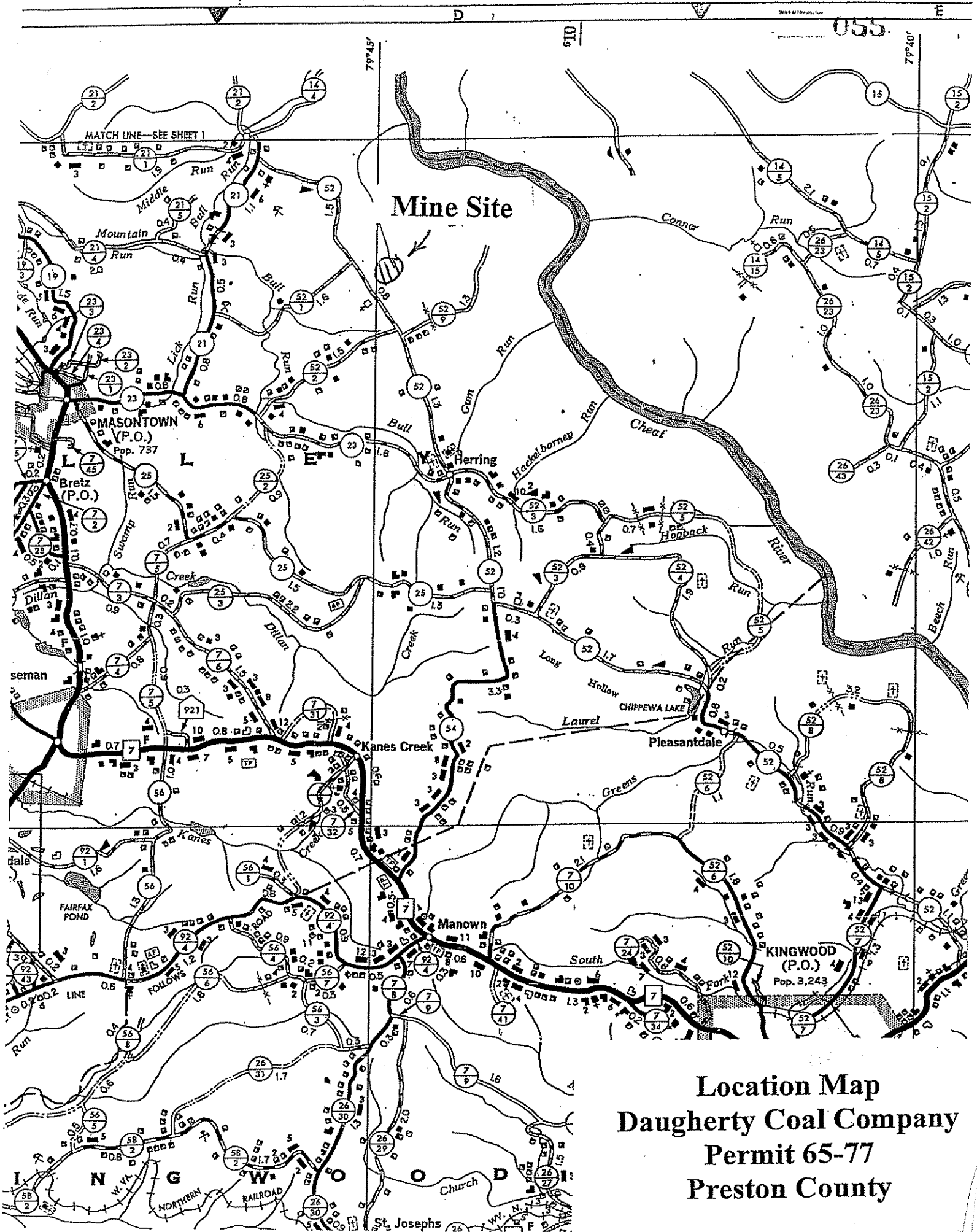

Location Map
 Daugherty Coal Company
 Permit 65-77
 Preston County

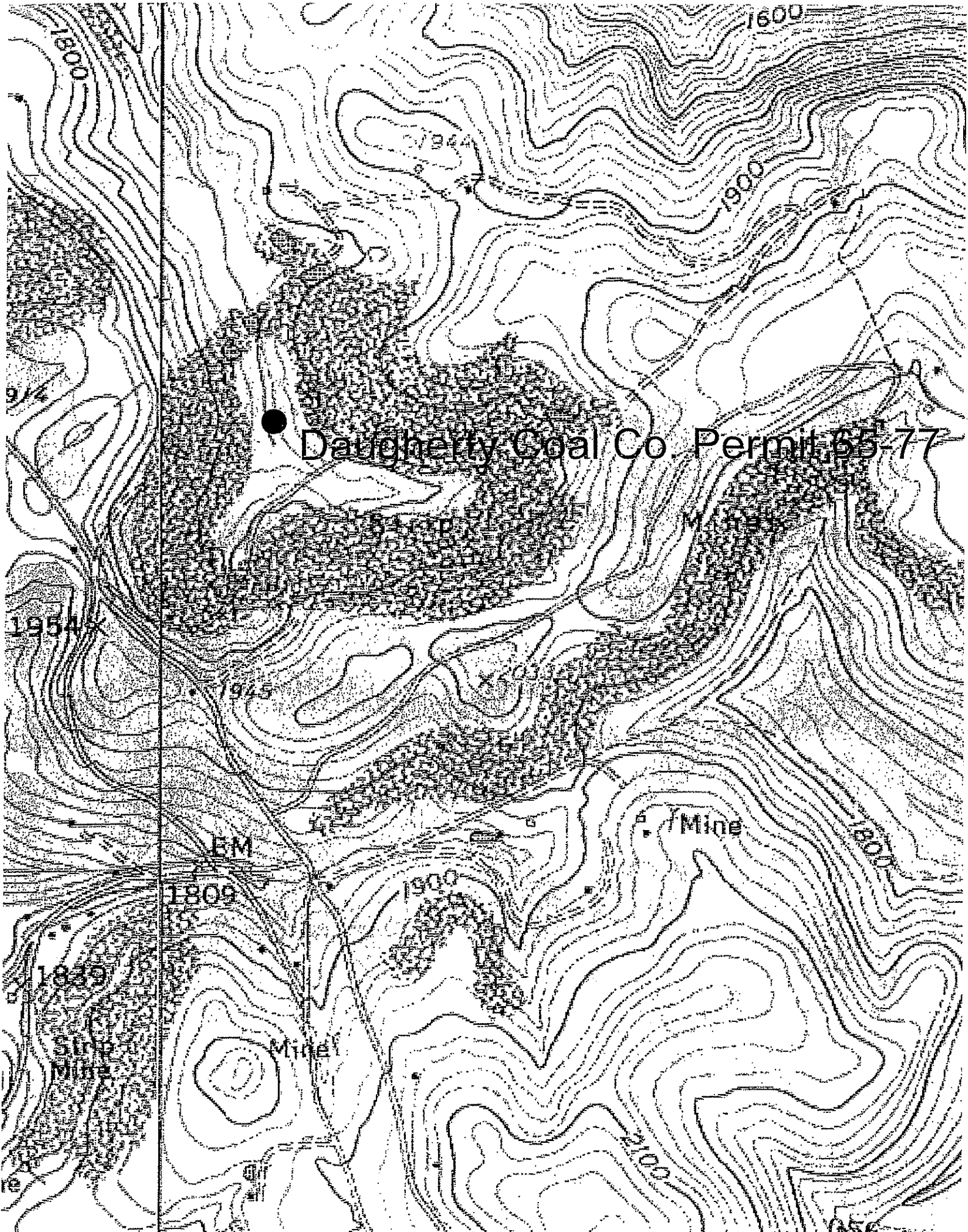

Contractors List

057

Company	First Name	Last Name	Address	City	State	Zip Code	Work Phone
ALWOOD COMPANY	JAMES	ALLEN	RT 1 BOX 452	CLARKSBURG	WV	26301-	(304) 623-5503
APPALACHIAN CONTRACTING CO	THANE	RYDER	HC-82 BOX 199	MARLINTON	WV	24954-	(304) 799-4488
AQUAFIX SYSTEMS INC	MIKE	JENKINS	301 MAPLE LANE	KINGWOOD	WV	26537-	(304) 329-1056
BARNES EXC INC	ROBERT	BARNES	PO BOX 13384	SISSONVILLE	WV	25360-	(304) 984-1725
BREAK AWAY INC	DOUG	VINCENT	1075 OLD TURNPIKE RD	SUTTON	WV	26601-	(304) 765-5317
CENTRAL CONTRACTING	STEVE	CVECHKO	PO BOX 1485	ST ALBANS	WV	25177-	(304) 722-7939
COLLINS BUILDING & CONTRACTING	ROGER	COLLINS	PO BOX 277	FLATWOODS	WV	26621-	(304) 765-3521
COWGIRL UP INC.	TINA	WOODDELL	PO BOX 243	SIMPSON	WV	26435-	(304) 739-4397
EAGLE EXCAVATION INC	GEORGE	FRESHOUR	PO BOX 218	KENNA	WV	25248-	(304) 372-4378
EASTERN ARROW	ANN	WARDWELL	PO BOX 365	CHARLESTON HEIG	WV	25040-	(304) 332-5522
G L STONE & SON INC	ALLEN	STONE	24 FIRST STREET	HAMLIN	WV	25523-	(304) 824-3600
GREEN MOUNTAIN COMPANY	RODNEY	CLAY	4 PORT AMHERST DRIVE	CHARLESTON	WV	25306-	(304) 925-0253
GROUND BREAKERS INC	DENNIS	ELBON	PO BOX 1227	CLARKSBURG	WV	26301-	(304) 622-2400
J B & SONS LLC	BILL	BOLINGER	RT 2 BOX 285	ALBRIGHT	WV	26519-	(304) 329-0490
MCCOURT & SON CONSTRUCTION INC	TOM	MCCOURT	2790 CENTRALIA ROAD	SUTTON	WV	26601-	(304) 765-5288
MOUNTAIN HAUS PROPERTIES	JOHN	SKIDMORE	305 39TH STREET	CHARLESTON	WV	25304-	(304) 925-4834
RBS INCORPORATED	RON	SNYDER	PO BOX 490	WHITE SULPHUR S	WV	24986-	(304) 645-2277
STANLEY INDUSTRIES INC	WAYNE	STANLEY	7 MAPLE LAKE	BRIDGEPORT	WV	26330-	(304) 842-8560
TRALYN INC	GERALD	GOODE	PO BOX 278	CABIN CREEK	WV	25035-	(304) 541-0346



058

west virginia department of environmental protection

Division of Land Restoration
Office of Special Reclamation
105 S Railroad Street Suite 301
Philippi WV 26416
Phone: 304-457-3219
Fax: 304-457-5613

Joe Manchin III, Governor
Stephanie R. Timmermeyer, Cabinet Secretary
www.wvdep.org

REQUISITION ACCOUNTING INFORMATION
Attach to all requisitions submitted to Headquarters

P O NUMBER: DEP13568

PERMIT NO.		PROJECT #		FUND	ORG	AMOUNT
65-77		06384		3312	9202	\$346,425.00

INSPECTOR NAME: Tim Lemasters

A F F I D A V I T061**West Virginia Code §5A-3-10a states:**

No contract or renewal of any contract may be awarded by the state or any of its political subdivisions to any vendor or prospective vendor when the vendor or prospective vendor or a related party to the vendor or prospective vendor is a debtor and the debt owned is an amount greater than one thousand dollars in the aggregate.

DEFINITIONS:

"Debt" means any assessment, premium, penalty, fine, tax or other amount of money owed to the state or any of its political subdivisions because of a judgment, fine, permit violation, license assessment, defaulted workers' compensation premium, penalty or other assessment presently delinquent or due and required to be paid to the state or any of its political subdivisions, including any interest or additional penalties accrued thereon.

"Debtor" means any individual, corporation, partnership, association, limited liability company or any other form or business association owing a debt to the state or any of its political subdivisions.

"Political subdivision" means any county commission; municipality; county board of education; any instrumentality established by a county or municipality; any separate corporation or instrumentality established by one or more counties or municipalities, as permitted by law; or any public body charged by law with the performance of a government function or whose jurisdiction is coextensive with one or more counties or municipalities.

"Related party" means a party, whether an individual, corporation, partnership, association, limited liability company or any other form or business association or other entity whatsoever, related to any vendor by blood, marriage, ownership or contract through which the party has a relationship of ownership or other interest with the vendor so that the party will actually or by effect receive or control a portion of the benefit, profit or other consideration from performance of a vendor contract with the party receiving an amount that meets or exceeds five percent of the total contract amount.

EXCEPTION:

The prohibition of this section does not apply where a vendor has contested any tax administered pursuant to chapter eleven of this code, workers' compensation premium, permit fee or environmental fee or assessment and the matter has not become final or where the vendor has entered into a payment plan or agreement and the vendor is not in default of any of the provisions of such plan or agreement.

LICENSING:

The vendor must be licensed in accordance with any and all state requirements to do business with the state of West Virginia.

CONFIDENTIALITY:

The vendor agrees that he or she will not disclose to anyone, directly or indirectly, any such personally identifiable information or other confidential information gained from the agency, unless the individual who is the subject of the information consents to the disclosure in writing or the disclosure is made pursuant to the agency's policies, procedures and rules. Vendors should visit www.state.wv.us/admin/purchase/privacy for the Notice of Agency Confidentiality Policies.

Under penalty of law for false swearing (West Virginia Code, §61-5-3), it is hereby certified that the vendor acknowledges the information in this said affidavit and are in compliance with the requirements as stated.

Vendor's Name: Allegheny Insurance ServicesAuthorized Signature: *Michael S. Mank*Date: 09-29-06

BID BOND

059

KNOW ALL MEN BY THESE PRESENTS, That we, the undersigned, Howard H. Harper, Triple H Const.
of Beverly, WV, as Principal, and Ohio Farmers Ins
of Westfield Center OH, a corporation organized and existing under the laws of the State of OH
with its principal office in the City of Westfield Center, as Surety, are held and firmly bound unto the State
of West Virginia, as Obligee, in the penal sum of 5% of Bid (\$ 450,000) for the payment of which,
well and truly to be made, we jointly and severally bind ourselves, our heirs, administrators, executors, successors and assigns.

The Condition of the above obligation is such that whereas the Principal has submitted to the Purchasing Section of the
Department of Administration a certain bid or proposal, attached hereto and made a part hereof, to enter into a contract in writing for
Water Reclamation-Daugherty Coal Company, Dept. of Enviromental
Protection.

NOW THEREFORE,

- (a) If said bid shall be rejected, or
- (b) If said bid shall be accepted and the Principal shall enter into a contract in accordance with the bid or proposal attached
hereto and shall furnish any other bonds and insurance required by the bid or proposal, and shall in all other respects perform the
agreement created by the acceptance of said bid, then this obligation shall be null and void, otherwise this obligation shall remain in full
force and effect. It is expressly understood and agreed that the liability of the Surety for any and all claims hereunder shall, in no event,
exceed the penal amount of this obligation as herein stated.

The Surety, for the value received, hereby stipulates and agrees that the obligations of said Surety and its bond shall be in no
way impaired or affected by any extension of the time within which the Obligee may accept such bid, and said Surety does hereby
waive notice of any such extension.

IN WITNESS WHEREOF, Principal and Surety have hereunto set their hands and seals, and such of them as are corporations
have caused their corporate seals to be affixed hereunto and these presents to be signed by their proper officers, this
29th day of September, 2006.

Principal Corporate Seal

Howard H. Harper
(Name of Principal)
By Howard H. Harper
(Must be President or
Vice President)

Owner
(Title)

Surety Corporate Seal

Ohio Farmers Insurance CO.
(Name of Surety)

James D. Waller
Attorney-in-Fact

IMPORTANT - Surety executing bonds must be licensed in West Virginia to transact surety insurance. Corporate seals must be affixed,
power of attorney must be attached

General Power of Attorney

Westfield Insurance Co. Westfield National Insurance Co. Ohio Farmers Insurance Co. Westfield Center, Ohio

CERTIFIED COPY

Know All Men by These Presents, That WESTFIELD INSURANCE COMPANY, WESTFIELD NATIONAL INSURANCE COMPANY and OHIO FARMERS INSURANCE COMPANY, corporations, hereinafter referred to individually as a "Company" and collectively as "Companies," duly organized and existing under the laws of the State of Ohio, and having its principal office in Westfield Center, Medina County, Ohio, do by these presents make, constitute and appoint JAMES W. WALLACE, DEANNA D. ARMENTROUT, MICHAEL A. CVECHKO, CINDEE J. CAMPBELL, JOINTLY OR SEVERALLY

of ELKINS and State of WV its true and lawful Attorney(s)-in-Fact, with full power and authority hereby conferred in its name, place and stead, to execute, acknowledge and deliver any and all bonds, recognizances, undertakings, or other instruments or contracts of suretyship-

LIMITATION: THIS POWER OF ATTORNEY CANNOT BE USED TO EXECUTE NOTE GUARANTEE, MORTGAGE DEFICIENCY, MORTGAGE GUARANTEE, OR BANK DEPOSITORY BONDS.

and to bind any of the Companies thereby as fully and to the same extent as if such bonds were signed by the President, sealed with the corporate seal of the applicable Company and duly attested by its Secretary, hereby ratifying and confirming all that the said Attorney(s)-in-Fact may do in the premises. Said appointment is made under and by authority of the following resolution adopted by the Board of Directors of each of the WESTFIELD INSURANCE COMPANY, WESTFIELD NATIONAL INSURANCE COMPANY and OHIO FARMERS INSURANCE COMPANY:

"Be It Resolved, that the President, any Senior Executive, any Secretary or any Fidelity & Surety Operations Executive or other Executive shall be and is hereby vested with full power and authority to appoint any one or more suitable persons as Attorney(s)-in-Fact to represent and act for and on behalf of the Company subject to the following provisions:

The Attorney-in-Fact, may be given full power and authority for and in the name of and on behalf of the Company, to execute, acknowledge and deliver, any and all bonds, recognizances, contracts, agreements of indemnity and other conditional or obligatory undertakings and any and all notices and documents canceling or terminating the Company's liability thereunder, and any such instruments so executed by any such Attorney-in-Fact shall be as binding upon the Company as if signed by the President and sealed and attested by the Corporate Secretary."

"Be it Further Resolved, that the signature of any such designated person and the seal of the Company heretofore or hereafter affixed to any power of attorney or any certificate relating thereto by facsimile, and any power of attorney or certificate bearing facsimile signatures or facsimile seal shall be valid and binding upon the Company with respect to any bond or undertaking to which it is attached." (Each adopted at a meeting held on February 8, 2000).

In Witness Whereof, WESTFIELD INSURANCE COMPANY, WESTFIELD NATIONAL INSURANCE COMPANY and OHIO FARMERS INSURANCE COMPANY have caused these presents to be signed by their Senior Executive and their corporate seals to be hereto affixed this 10th day of AUGUST A.D., 2006.

Corporate Seals Affixed



WESTFIELD INSURANCE COMPANY WESTFIELD NATIONAL INSURANCE COMPANY OHIO FARMERS INSURANCE COMPANY

Richard L. Kinnaird, Jr. By: Richard L. Kinnaird, Jr., Senior Executive

State of Ohio County of Medina ss.:

On this 10th day of AUGUST A.D., 2006, before me personally came Richard L. Kinnaird, Jr. to me known, who, being by me duly sworn, did depose and say, that he resides in Medina, Ohio; that he is Senior Executive of WESTFIELD INSURANCE COMPANY, WESTFIELD NATIONAL INSURANCE COMPANY and OHIO FARMERS INSURANCE COMPANY, the companies described in and which executed the above instrument; that he knows the seals of said Companies; that the seals affixed to said instrument are such corporate seals; that they were so affixed by order of the Boards of Directors of said Companies; and that he signed his name thereto by like order.

Notarial Seal Affixed



State of Ohio County of Medina ss.:

William J. Kahelin, Attorney at Law, Notary Public My Commission Does Not Expire (Sec. 147.03 Ohio Revised Code)

I, Frank A. Carrino, Secretary of WESTFIELD INSURANCE COMPANY, WESTFIELD NATIONAL INSURANCE COMPANY and OHIO FARMERS INSURANCE COMPANY, do hereby certify that the above and foregoing is a true and correct copy of a Power of Attorney, executed by said Companies, which is still in full force and effect; and furthermore, the resolutions of the Boards of Directors, set out in the Power of Attorney are in full force and effect.

In Witness Whereof, I have hereunto set my hand and affixed the seals of said Companies at Westfield Center, Ohio, this day of A.D.,



Frank A. Carrino Secretary