



State of West Virginia  
 Department of Administration  
 Purchasing Division  
 2019 Washington Street East  
 Post Office Box 50130  
 Charleston, WV 25305-0130

# Request for Quotation

RFQ NUMBER  
**DEFK7031**

PAGE  
**1**

ADDRESS CORRESPONDENCE TO ATTENTION OF:  
**CHUCK BOWMAN**  
**304-558-2157**

RFQ COPY

TYPE NAME/ADDRESS HERE

VENDOR

**H.E. NEUMANN Co.**  
**1410 6TH. AVE**  
**CHARLESTON, WV 25312**

SHIP TO

**DIV ENGINEERING & FACILITIES**  
**NATIONAL GUARD ARMORY**  
**ROUTE 4, SOUTH**  
**BUCKHANNON, WV**  
**26201 341-6368**

DATE PRINTED	TERMS OF SALE	SHIP VIA	F.O.B.	FREIGHT TERMS
07/19/2006				

BID OPENING DATE: **08/30/2006** BID OPENING TIME **01:30PM**

LINE	QUANTITY	UOP	CAT. NO.	ITEM NUMBER	UNIT PRICE	AMOUNT
0001	1	JB		031-06		<b>\$30,612.00</b>
<p><b>AIR CONDITIONING AND HEATING, CENTRAL UNITS</b></p> <p>THE WEST VIRGINIA PURCHASING DIVISION, ON BEHALF OF THE AGENCY, THE WEST VIRGINIA ADJUTANT GENERAL'S DEPARTMENT DIVISION OF ENGINEERING AND FACILITIES, IS SOLICITING BIDS FROM QUALIFIED CONTRACTORS TO PROVIDE ALL LABOR, MATERIALS, EQUIPMENT, AND ACCESSORIES NECESSARY TO PROVIDE FOR THE REPLACEMENT OF AN EXISTING HVAC SYSTEM, (8 TON DATA AIR UNIT) IN THE EXISTING COMPUTER ROOM AT THE USFPO LOCATED AT 50 ARMORY ROAD IN BUCKHANNON, WV, PER THE FOLLOWING SPECIFICATIONS, BID REQUIREMENTS, AND TERMS &amp; CONDITIONS.</p> <p>A MANDATORY ON-SITE PRE-BID CONFERENCE IS SCHEDULED FOR TUES., AUGUST 08, 2006, AT 10:30 AM. FAILURE TO ATTEND THIS MANDATORY MEETING WILL RESULT IN THE DISQUALIFICATION OF BID SUBMITTAL FROM ANY NON-ATTENDING VENDOR.</p> <p>THE FOLLOWING DIRECTIONS TO THE SITE ARE PROVIDED BY GOOGLE MAPS: FROM EXIT 99 OFF I-79 TO WESTON/BUCKHANNON TRAVEL ON US-119/US-33 FOR 11 MILES, TAKE CR-12 RAMP &amp; TRAVEL 0.3 MILES, TURN RIGHT AT CR-12 AND TRAVEL 0.6 MILES, TURN RIGHT AT WV-20 AND GO 1.5 MILES, TURN LEFT AT SENECA DRIVE AND GO 0.1 MILES, BEAR LEFT AT ARMORY ROAD AND FACILITY IS WITHIN 50 FT OF TURN-OFF.</p> <p>IT IS THE RESPONSIBILITY OF THE CONTRACTOR TO VERIFY SITE CONDITIONS, TAKE ACCURATE MEASUREMENTS, AND TO PROPERLY DISPOSE OF EXISTING UNIT AND ALL RESIDUE ASSOCIATED WITH THE DEMOLITION AT THE SITE.</p>						

SEE REVERSE SIDE FOR TERMS AND CONDITIONS

SIGNATURE <i>Steve Edelman</i>	TELEPHONE <b>304-345-5580</b>	DATE <b>8-25-06</b>
TITLE <i>Project Sales Mgr.</i>	FEIN <b>55-0243140</b>	ADDRESS CHANGES TO BE NOTED ABOVE

WHEN RESPONDING TO RFQ, INSERT NAME AND ADDRESS IN SPACE ABOVE LABELED 'VENDOR'

**GENERAL TERMS & CONDITIONS  
REQUEST FOR QUOTATION (RFQ) AND REQUEST FOR PROPOSAL (RFP)**

1. Awards will be made in the best interest of the State of West Virginia.
2. The State may accept or reject in part, or in whole, any bid.
3. All quotations are governed by the *West Virginia Code* and the *Legislative Rules* of the Purchasing Division.
4. Prior to any award, the apparent successful vendor must be properly registered with the Purchasing Division and have paid the required \$125.00 registration fee.
5. All services performed or goods delivered under State Purchase Orders/Contracts are to be continued for the term of the Purchase Order/Contract, contingent upon funds being appropriated by the Legislature or otherwise being made available. In the event funds are not appropriated or otherwise available for these services or goods, this Purchase Order/Contract becomes void and of no effect after June 30.
6. Payment may only be made after the delivery and acceptance of goods or services.
7. Interest may be paid for late payment in accordance with the *West Virginia Code*.
8. Vendor preference will be granted upon written request in accordance with the *West Virginia Code*.
9. The State of West Virginia is exempt from federal and state taxes and will not pay or reimburse such taxes.
10. The Director of Purchasing may cancel any Purchase Order/Contract upon 30 days written notice to the seller.
11. The laws of the State of West Virginia and the *Legislative Rules* of the Purchasing Division shall govern all rights and duties under the Contract, including without limitation the validity of this Purchase Order/Contract.
12. Any reference to automatic renewal is hereby deleted. The Contract may be renewed only upon mutual written agreement of the parties.
13. **BANKRUPTCY:** In the event the vendor/contractor files for bankruptcy protection, this contract is automatically null and void, and is terminated without further order.
14. **HIPAA Business Associate Addendum** - The West Virginia State Government HIPAA Business Associate Addendum (BAA), approved by the Attorney General, and available online at the Purchasing Division's web site (<http://www.state.wv.us/admin/purchase/vrc/hipaa.htm>) is hereby made part of the agreement. Provided that, the Agency meets the definition of a Covered Entity (45 CFR §160.103) and will be disclosing Protected Health Information (45 CFR §160.103) to the vendor.

---

**INSTRUCTIONS TO BIDDERS**

1. Use the quotation forms provided by the Purchasing Division.
2. **SPECIFICATIONS:** Items offered must be in compliance with the specifications. Any deviation from the specifications must be clearly indicated by the bidder. Alternates offered by the bidder as **EQUAL** to the specifications must be clearly defined. A bidder offering an alternate should attach complete specifications and literature to the bid. The Purchasing Division may waive minor deviations to specifications.
3. Complete all sections of the quotation form.
4. Unit prices shall prevail in cases of discrepancy.
5. All quotations are considered F.O.B. destination unless alternate shipping terms are clearly identified in the quotation.
6. **BID SUBMISSION:** All quotations must be delivered by the bidder to the office listed below prior to the date and time of the bid opening. Failure of the bidder to deliver the quotations on time will result in bid disqualifications.

**SIGNED BID TO:**

Department of Administration  
Purchasing Division  
2019 Washington Street East  
Post Office Box 50130  
Charleston, WV 25305-0130



State of West Virginia  
 Department of Administration  
 Purchasing Division  
 2019 Washington Street East  
 Post Office Box 50130  
 Charleston, WV 25305-0130

# Request for Quotation

RFO NUMBER  
**DEFK7031**

PAGE  
**2**

ADDRESS CORRESPONDENCE TO ATTENTION OF:  
**CHUCK BOWMAN**  
**304-558-2157**

VENDOR

RFQ COPY  
 TYPE NAME/ADDRESS HERE

SHIP TO

DIV ENGINEERING & FACILITIES  
 NATIONAL GUARD ARMORY  
 ROUTE 4, SOUTH  
 BUCKHANNON, WV  
 26201 341-6368

DATE PRINTED <b>07/19/2006</b>	TERMS OF SALE	SHIP VIA	F.O.B.	FREIGHT TERMS
-----------------------------------	---------------	----------	--------	---------------

BID OPENING DATE: **08/30/2006** BID OPENING TIME **01:30PM**

LINE	QUANTITY	UOP	CAT NO.	ITEM NUMBER	UNIT PRICE	AMOUNT
<p>CONTRACTOR SHOULD SUBMIT THE FOLLOWING WITH THEIR ALL INCLUSIVE PRICE: MANUFACTURER MAKE AND MODEL COMPLETE WITH FACTORY SPECIFICATIONS OR CUT SHEETS INDICATING PERFORMANCE CRITERIA AND PHYSICAL DIMENSIONS AND A COMPLETE QUANTITY LIST OF MATERIALS AND ACCESSORIES REQUIRED FOR INSTALLATION. THE AGENCY RESERVES THE RIGHT TO REQUEST THIS INFORMATION OR ADDITIONAL INFORMATION AND EXPECT IT TO BE PROVIDED IN A TIMELY MANNER AT ANY TIME DURING THE EVALUATION PROCESS OF THIS RFQ. CONTRACTOR'S FAILURE TO RESPOND TIMELY TO SUCH A REQUEST MAY RESULT IN THE DISQUALIFICATION OF THE VENDOR'S BID PROPOSAL.</p> <p>THE AGENCY REQUESTS A BASE BID PRICE FOR THE REPLACEMENT OF AN 8-TON UNIT AND AN ALTERNATE PRICE TO REPLACE THE UNIT WITH (2) 5-TON UNITS. VENDOR SHOULD PROVIDE TECHNICAL INFORMATION FOR BOTH SIZES OF UNITS AS BID FOR THE BASE AND THE ALTERNATE. PLEASE PROVIDE PRICE FOR BASE AND ALTERNATE IN THE SPACE PROVIDED BELOW:</p> <p>BASE BID: (1) 8 TON UNIT, INCLUSIVE OF ALL MATERIALS, EQUIPMENT, LABOR, &amp; ACCESSORIES. MANUFACTURER TECHNICAL DATA ATTACHED.</p> <p>\$-----</p> <p><del>ALTERNATE BID: (2) 5-TON UNITS, INCLUSIVE OF ALL MATERIALS, EQUIPMENT, LABOR, &amp; ACCESSORIES. MANUFACTURER TECHNICAL DATA ATTACHED.</del></p> <p>\$-----</p>						

SEE REVERSE SIDE FOR TERMS AND CONDITIONS

SIGNATURE <i>Chuck Bowman</i>	TELEPHONE <b>304-345-5580</b>	DATE <b>8-25-06</b>
TITLE <i>Project Manager</i>	FEIN <b>55-0243140</b>	ADDRESS CHANGES TO BE NOTED ABOVE

WHEN RESPONDING TO RFQ, INSERT NAME AND ADDRESS IN SPACE ABOVE LABELED 'VENDOR'



State of West Virginia  
 Department of Administration  
 Purchasing Division  
 2019 Washington Street East  
 Post Office Box 50130  
 Charleston, WV 25305-0130

**Request for  
 Quotation**

RFO NUMBER  
**DEFK7031**

PAGE  
**3**

ADDRESS CORRESPONDENCE TO ATTENTION OF:  
**CHUCK BOWMAN  
 304-558-2157**

VENDOR

RFQ COPY  
 TYPE NAME/ADDRESS HERE

SHIP TO

**DIV ENGINEERING & FACILITIES  
 NATIONAL GUARD ARMORY  
 ROUTE 4, SOUTH  
 BUCKHANNON, WV  
 26201 341-6368**

DATE PRINTED <b>07/19/2006</b>	TERMS OF SALE	SHIP VIA	F.O.B.	FREIGHT TERMS
-----------------------------------	---------------	----------	--------	---------------

BID OPENING DATE: **08/30/2006** BID OPENING TIME **01:30PM**

LINE	QUANTITY	UOP	CAT. NO.	ITEM NUMBER	UNIT PRICE	AMOUNT
<p>PLEASE PAY CLOSE ATTENTION THE THE FOLLOWING BID REQUIREMENTS AS THEY PERTAIN TO THE SUBMISSION OF PRICE PROPOSALS FOR THIS PROJECT.</p> <p>EXHIBIT 5</p> <p>NOTICE TO PROCEED: THIS CONTRACT IS TO BE PERFORMED WITHIN -60- CALENDAR DAYS AFTER THE NOTICE TO PROCEED IS RECEIVED. UNLESS OTHERWISE SPECIFIED, THE FULLY EXECUTED PURCHASE ORDER WILL BE CONSIDERED NOTICE TO PROCEED.</p> <p>CANCELLATION: THE DIRECTOR OF PURCHASING RESERVES THE RIGHT TO CANCEL THIS CONTRACT IMMEDIATELY UPON WRITTEN NOTICE TO THE VENDOR IF THE MATERIALS OR WORKMANSHIP SUPPLIED ARE OF AN INFERIOR QUALITY OR DO NOT CONFORM WITH THE SPECIFICATIONS OF THE BID AND CONTRACT HERE IN.</p> <p>WAGE RATES: THE CONTRACTOR OR SUBCONTRACTOR SHALL PAY THE HIGHER OF THE U.S. DEPARTMENT OF LABOR MINIMUM WAGE RATES AS ESTABLISHED FOR UPSHUR COUNTY, PURSUANT TO WEST VIRGINIA CODE 21-5A, ET, SEQ. (PREVAILING WAGE RATES APPLY TO THIS PROJECT)</p> <p>ARBITRATION: ANY REFERENCES MADE TO ARBITRATION OR INTEREST FOR PAYMENTS DUE (EXCEPT FOR ANY INTEREST REQUIRED BY STATE LAW) CONTAINED IN THIS CONTRACT OR IN ANY AMERICAN INSTITUTE OF ARCHITECTS DOCUMENTS PERTAINING TO THIS CONTRACT ARE HEREBY DELETED.</p> <p>WORKERS' COMPENSATION: VENDOR IS REQUIRED TO PROVIDE A CERTIFICATE FROM WORKERS' COMPENSATION IF SUCCESSFUL.</p>						

SEE REVERSE SIDE FOR TERMS AND CONDITIONS

SIGNATURE <i>Chuck Bowman</i>	TELEPHONE <b>304-345-5580</b>	DATE <b>8-25-06</b>
PROJECT NO. <b>55-0243140</b>	ADDRESS CHANGES TO BE NOTED ABOVE	

WHEN RESPONDING TO RFQ, INSERT NAME AND ADDRESS IN SPACE ABOVE LABELED 'VENDOR'



State of West Virginia  
 Department of Administration  
 Purchasing Division  
 2019 Washington Street East  
 Post Office Box 50130  
 Charleston, WV 25305-0130

# Request for Quotation

RFQ NUMBER  
**DEFK7031**

PAGE  
**4**

ADDRESS CORRESPONDENCE TO ATTENTION OF:  
**CHUCK BOWMAN**  
**304-558-2157**

VENDOR

RFQ COPY  
 TYPE NAME/ADDRESS HERE

SHIP TO

DIV ENGINEERING & FACILITIES  
 NATIONAL GUARD ARMORY  
 ROUTE 4, SOUTH  
 BUCKHANNON, WV  
 26201 341-6368

DATE PRINTED <b>07/19/2006</b>	TERMS OF SALE	SHIP VIA	F.O.B.	FREIGHT TERMS
-----------------------------------	---------------	----------	--------	---------------

BID OPENING DATE: **08/30/2006** BID OPENING TIME **01:30PM**

LINE	QUANTITY	UOP	CAT NO	ITEM NUMBER	UNIT PRICE	AMOUNT
<p>ALL OF THE ITEMS CHECKED BELOW WILL BE A REQUIREMENT OF THIS CONTRACT:</p> <p>(XX) INSURANCE: SUCCESSFUL VENDOR SHALL FURNISH PROOF OF COMMERCIAL GENERAL LIABILITY INSURANCE PRIOR TO ISSUANCE OF CONTRACT. UNLESS OTHERWISE SPECIFIED IN THE BID DOCUMENTS, THE MINIMUM AMOUNT OF INSURANCE COVERAGE REQUIRED IS \$250,000.</p> <p>( ) BUILDERS RISK INSURANCE: SUCCESSFUL VENDOR SHALL FURNISH PROOF OF BUILDERS RISK - ALL RISK INSURANCE IN AN AMOUNT EQUAL TO 100% OF THE AMOUNT OF THE CONTRACT.</p> <p>(XX) BONDS: FIVE PERCENT (5%) OF THE TOTAL AMOUNT OF THE BID PAYABLE TO THE STATE OF WEST VIRGINIA, SHALL BE SUBMITTED WITH EACH BID AS A BID BOND. THE SUCCESSFUL BIDDER SHALL ALSO FURNISH A PERFORMANCE BOND AND LABOR/MATERIAL BOND FOR 100% OF THE AMOUNT OF THE CONTRACT. BONDS MAY BE PROVIDED IN THE FORM OF A CERTIFIED CHECK, IRREVOCABLE LETTER OF CREDIT, OR BOND FURNISHED BY A SOLVENT SURETY COMPANY AUTHORIZED TO DO BUSINESS IN THE STATE OF WEST VIRGINIA. A LETTER OF CREDIT SUBMITTED IN LIEU OF A PERFORMANCE AND LABOR &amp; MATERIAL BOND WILL ONLY BE ALLOWED FOR PROJECTS UNDER \$100,000. PERSONAL OR BUSINESS CHECKS ARE NOT ACCEPCTABLE IN LIEU OF THE 5% BID BOND, PERFORMANCE BOND, OR LABOR AND MATERIAL BOND.</p> <p>( ) MAINTENANCE BOND: A TWO (2) YEAR MAINTENANCE BOND COVERING THE ROOFING SYSTEM WILL BE A REQUIREMENT OF THE SUCCESSFUL VENDOR.</p> <p>REV. 11/00</p> <p>EXHIBIT 7</p>						

SEE REVERSE SIDE FOR TERMS AND CONDITIONS

SIGNATURE <i>Chuck Bowman</i>	TELEPHONE <b>304-345-5580</b>	DATE <b>8-25-06</b>
TITLE <i>Project Manager</i>	FEIN <b>55-0243140</b>	ADDRESS CHANGES TO BE NOTED ABOVE

WHEN RESPONDING TO RFQ, INSERT NAME AND ADDRESS IN SPACE ABOVE LABELED 'VENDOR'



State of West Virginia  
 Department of Administration  
 Purchasing Division  
 2019 Washington Street East  
 Post Office Box 50130  
 Charleston, WV 25305-0130

**Request for  
 Quotation**

RFQ NUMBER  
**DEFK7031**

PAGE  
**5**

ADDRESS CORRESPONDENCE TO ATTENTION OF:  
**CHUCK BOWMAN  
 304-558-2157**

VENDOR

RFQ COPY  
 TYPE NAME/ADDRESS HERE

SHIP TO

**DIV ENGINEERING & FACILITIES  
 NATIONAL GUARD ARMORY  
 ROUTE 4, SOUTH  
 BUCKHANNON, WV  
 26201 341-6368**

DATE PRINTED <b>07/19/2006</b>	TERMS OF SALE	SHIP VIA	F.O.B.	FREIGHT TERMS
-----------------------------------	---------------	----------	--------	---------------

BID OPENING DATE: **08/30/2006** BID OPENING TIME **01:30PM**

LINE	QUANTITY	UOP	CAT. NO.	ITEM NUMBER	UNIT PRICE	AMOUNT
<p>DOMESTIC ALUMINUM, GLASS &amp; STEEL IN PUBLIC WORKS PROJECTS</p> <p>IN ACCORDANCE WITH WEST VIRGINIA CODE 5-19-1 ET., SEQ., EVERY CONTRACT FOR CONSTRUCTION, RECONSTRUCTION, ALTERATION, REPAIR, IMPROVEMENT OR MAINTENANCE OF PUBLIC WORKS, WHERE THE COST IS MORE THAN \$50,000 AND, IN THE CASE OF STEEL ONLY, WHERE THE COST OF STEEL IS MORE THAN \$50,000 OR WHERE MORE THAN 10,000 POUNDS OF STEEL ARE REQUIRED, THE STATE WILL ACCEPT ONLY ALUMINUM GLASS, OR STEEL PRODUCTS PRODUCED IN THE UNITED STATES IN ADDITION, ITEMS OF MACHINERY OR EQUIPMENT PURCHASED FOR USE AT THE SITE OF PUBLIC WORKS SHALL BE MADE OF DOMESTIC ALUMINUM, GLASS OR STEEL, UNLESS THE COST OF THE PRODUCT IS LESS THAN \$50,000 OR LESS THAN 10,000 POUNDS OF STEEL ARE USED IN PUBLIC WORKS PROJECTS.</p> <p>FOREIGN MADE ALUMINUM, GLASS OR STEEL PRODUCTS MAY BE ACCEPTED ONLY IF THE COST OF DOMESTIC PRODUCTS IS FOUND TO BE UNREASONABLE. SUCH COST IS UNREASONABLE IF IT IS 20% OR MORE HIGHER THAN THE BID PRICE FOR FOREIGN MADE PRODUCTS. IF THE DOMESTIC ALUMINUM, GLASS OR STEEL PRODUCTS TO BE SUPPLIED OR PRODUCED IN A "SUBSTANTIAL LABOR SURPLUS AREA", AS DEFINED BY THE UNITED STATES DEPARTMENT OF LABOR, FOREIGN PRODUCTS MAY BE SUPPLIED ONLY IF DOMESTIC PRODUCTS ARE 30% OR MORE HIGHER IN PRICE THAN THE FOREIGN MADE PRODUCTS.</p> <p>IF, PRIOR TO THE AWARD OF A CONTRACT UNDER THE ABOVE PROVISIONS, THE SPENDING OFFICER OF THE SPENDING UNIT DETERMINES THAT THERE EXISTS A BID FOR LIKE FOREIGN ALUMINUM, GLASS OR STEEL THAT IS REASONABLE AND LOWER THAN THE LOWEST BID DOMESTIC PRODUCTS, THE SPENDING OFFICE MAY REQUEST, IN WRITING, A REEVALUATION AND REDUCTION IN THE LOWEST BID FOR SUCH DOMESTIC PRODUCTS</p>						

SEE REVERSE SIDE FOR TERMS AND CONDITIONS

SIGNATURE <i>Steve Edelman</i>	TELEPHONE <b>304-345-5580</b>	DATE <b>8-25-06</b>
PROJECT <i>Project Schilling</i>	FEIN <b>55-0243140</b>	ADDRESS CHANGES TO BE NOTED ABOVE

WHEN RESPONDING TO RFQ, INSERT NAME AND ADDRESS IN SPACE ABOVE LABELED 'VENDOR'



State of West Virginia  
 Department of Administration  
 Purchasing Division  
 2019 Washington Street East  
 Post Office Box 50130  
 Charleston, WV 25305-0130

# Request for Quotation

RFQ NUMBER  
**DEFK7031**

PAGE  
**6**

ADDRESS CORRESPONDENCE TO ATTENTION OF:  
**CHUCK BOWMAN**  
**304-558-2157**

RFQ COPY  
 TYPE NAME/ADDRESS HERE

VENDOR

SHIP TO

**DIV ENGINEERING & FACILITIES**  
**NATIONAL GUARD ARMORY**  
**ROUTE 4, SOUTH**  
  
**BUCKHANNON, WV**  
**26201 341-6368**

DATE PRINTED <b>07/19/2006</b>	TERMS OF SALE	SHIP VIA	F.O.B.	FREIGHT TERMS
-----------------------------------	---------------	----------	--------	---------------

BID OPENING DATE: **08/30/2006** BID OPENING TIME **01:30PM**

LINE	QUANTITY	UOP	CAT. NO.	ITEM NUMBER	UNIT PRICE	AMOUNT
<p>ALL VENDORS MUST INDICATE IN THEIR BID IF THEY ARE SUPPLYING FOREIGN ALUMINUM, GLASS OR STEEL.</p> <p>REV. 3/88</p> <p>EXHIBIT 9</p> <p>NOTICE FOR ISSUANCE &amp; ACKNOWLEDGEMENT OF CONSTRUCTION PROJECT ADDENDA</p> <p>THE ARCHITECT/ENGINEER AND/OR AGENCY SHALL BE REQUIRED TO ABIDE BY THE FOLLOWING SCHEDULE IN ISSUING CONSTRUCTION PROJECT ADDENDA FOR STATE AGENCIES:</p> <p>(1) THE ARCHITECT/ENGINEER SHALL PREPARE THE ADDENDUM AND A LIST OF ALL PARTIES THAT HAVE PROCURED DRAWINGS AND SPECIFICATIONS FOR THE PROJECT. THE ADDENDUM AND LIST SHALL BE FORWARDED TO THE BUYER IN THE STATE PURCHASING DIVISION. THE ARCHITECT/ENGINEER SHALL ALSO SEND A COPY OF THE ADDENDUM TO THE STATE AGENCY FOR WHICH THE CONTRACT IS ISSUED.</p> <p>(2) THE BUYER SHALL SEND THE ADDENDUM TO ALL INTERESTED PARTIES AND, IF NECESSARY, EXTEND THE BID OPENING DATE. ANY ADDENDUM SHOULD BE RECEIVED BY THE BUYER WITHIN FOURTEEN (14) DAYS PRIOR TO THE BID OPENING DATE.</p> <p>(3) ALL ADDENDA SHOULD BE FORMALLY ACKNOWLEDGED BY ALL BIDDERS AND SUBMITTED TO THE STATE PURCHASING DIVISION AND THE STATE AUDITOR'S OFFICE. THE SAME RULES AND REGULATIONS THAT APPLY TO THE ORIGINAL BIDDING DOCUMENT SHALL ALSO APPLY TO AN ADDENDUM DOCUMENT. THE ONLY EXCEPTION MAY BE FOR AN ADDENDUM THAT IS ISSUED FOR THE SOLE PURPOSE OF CHANGING A BID OPENING TIME AND/OR</p>						

SEE REVERSE SIDE FOR TERMS AND CONDITIONS

SIGNATURE <i>Alex Edelmann</i>	TELEPHONE <b>304-345-5580</b>	DATE <b>8-25-06</b>
TITLE <i>Project Admin Mgr</i>	FEIN <b>55-0243140</b>	ADDRESS CHANGES TO BE NOTED ABOVE

WHEN RESPONDING TO RFQ, INSERT NAME AND ADDRESS IN SPACE ABOVE LABELED 'VENDOR'



State of West Virginia  
 Department of Administration  
 Purchasing Division  
 2019 Washington Street East  
 Post Office Box 50130  
 Charleston, WV 25305-0130

# Request for Quotation

RFQ NUMBER  
**DEFK7031**

PAGE  
**7**

ADDRESS CORRESPONDENCE TO ATTENTION OF:  
**CHUCK BOWMAN**  
**304-558-2157**

VENDOR

RFQ COPY  
 TYPE NAME/ADDRESS HERE

SHIP TO

**DIV ENGINEERING & FACILITIES**  
**NATIONAL GUARD ARMORY**  
**ROUTE 4, SOUTH**  
  
**BUCKHANNON, WV**  
**26201**                      **341-6368**

DATE PRINTED <b>07/19/2006</b>	TERMS OF SALE	SHIP VIA	F.O.B.	FREIGHT TERMS
-----------------------------------	---------------	----------	--------	---------------

BID OPENING DATE: **08/30/2006**                      BID OPENING TIME **01:30PM**

LINE	QUANTITY	UOP	CAT. NO.	ITEM NUMBER	UNIT PRICE	AMOUNT
DATE. REV. 11/96  EXHIBIT 10  ADDENDUM ACKNOWLEDGEMENT  I HEREBY ACKNOWLEDGE RECEIPT OF THE FOLLOWING CHECKED ADDENDUM(S) AND HAVE MADE THE NECESSARY REVISIONS TO MY PROPOSAL, PLANS AND/OR SPECIFICATION, ETC.  ADDENDUM NOS.: NO. 1                      ..... ✓ ..... NO. 2                      ..... NO. 3                      ..... NO. 4                      ..... NO. 5                      .....  I UNDERSTAND THAT FAILURE TO CONFIRM THE RECEIPT OF THE ADDENDUM(S) MAY BE CAUSE FOR REJECTION OF THE BIDS.  <i>H. E. Neumann</i> ..... SIGNATURE <b>H. E. NEUMANN Co.</b> ..... COMPANY ..... <b>8-25-06</b> ..... DATE  REV. 11/96						

SEE REVERSE SIDE FOR TERMS AND CONDITIONS

GNAT FILE <i>H. E. Neumann</i>	TELEPHONE <b>304-345-5580</b>	DATE <b>8-25-06</b>
FEIN <b>55-0243140</b>	ADDRESS CHANGES TO BE NOTED ABOVE	

WHEN RESPONDING TO RFQ, INSERT NAME AND ADDRESS IN SPACE ABOVE LABELED 'VENDOR'





State of West Virginia  
 Department of Administration  
 Purchasing Division  
 2019 Washington Street East  
 Post Office Box 50130  
 Charleston, WV 25305-0130

# Request for Quotation

RFQ NUMBER
DEFK7031

PAGE
8

ADDRESS CORRESPONDENCE TO ATTENTION OF:
CHUCK BOWMAN 304-558-2157

RFQ COPY
TYPE NAME/ADDRESS HERE
VENDOR

SHIP TO
DIV ENGINEERING & FACILITIES NATIONAL GUARD ARMORY ROUTE 4, SOUTH BUCKHANNON, WV 26201 341-6368

DATE PRINTED 07/19/2006	TERMS OF SALE	SHIP VIA	F.O.B.	FREIGHT TERMS
----------------------------	---------------	----------	--------	---------------

BID OPENING DATE: 08/30/2006 BID OPENING TIME 01:30PM

LINE	QUANTITY	UOP	CAT NO	ITEM NUMBER	UNIT PRICE	AMOUNT
<p><b>CONTRACTORS LICENSE</b></p> <p>WEST VIRGINIA STATE CODE 21-11-2 REQUIRES THAT ALL PERSONS DESIRING TO PERFORM CONTRACTING WORK IN THIS STATE MUST BE LICENSED. THE WEST VIRGINIA CONTRACTORS LICENSING BOARD IS EMPOWERED TO ISSUE THE CONTRACTORS LICENSE. APPLICATIONS FOR A CONTRACTORS LICENSE MAY BE MADE BY CONTACTING THE WEST VIRGINIA DIVISION OF LABOR CAPITOL COMPLEX, BUILDING 3, ROOM 319, CHARLESTON, WV 25305. TELEPHONE: (304) 558-7890.</p> <p>WEST VIRGINIA STATE CODE 21-11-11 REQUIRES ANY PROSPECTIVE BIDDER TO INCLUDE THE CONTRACTORS LICENSE NUMBER ON THEIR BID.</p> <p>BIDDER TO COMPLETE:</p> <p>CONTRACTORS NAME: ..... <b>H.E. NEUMANN Co</b> .....</p> <p>CONTRACTORS LICENSE NO.: ..... <b>WY0004</b> .....</p> <p>THE SUCCESSFUL BIDDER WILL BE REQUIRED TO FURNISH A COPY OF THEIR CONTRACTORS LICENSE PRIOR TO ISSUANCE OF A PURCHASE ORDER/CONTRACT</p> <p><b>APPLICABLE LAW</b></p> <p>THE WEST VIRGINIA STATE CODE, PURCHASING DIVISION RULE AND REGULATIONS, AND THE INFORMATION PROVIDED IN THE "REQUEST FOR QUOTATION" ISSUED BY THE PURCHASING DIVISION IS THE SOLE AUTHORITY GOVERNING THIS PROCUREMENT.</p> <p>ANY INFORMATION PROVIDED IN SPECIFICATION MANUALS, OR</p>						

SEE REVERSE SIDE FOR TERMS AND CONDITIONS

SIGNATURE <i>Olga Edelmann</i>	TELEPHONE <b>304-345-5580</b>	DATE <b>8-25-06</b>
TITLE <i>Project Manager</i>	FERN <b>55-0243140</b>	ADDRESS CHANGES TO BE NOTED ABOVE

WHEN RESPONDING TO RFQ, INSERT NAME AND ADDRESS IN SPACE ABOVE LABELED 'VENDOR'



State of West Virginia  
 Department of Administration  
 Purchasing Division  
 2019 Washington Street East  
 Post Office Box 50130  
 Charleston, WV 25305-0130

**Request for  
 Quotation**

RFQ NUMBER  
**DEFK7031**

PAGE  
**9**

ADDRESS CORRESPONDENCE TO ATTENTION OF:  
**CHUCK BOWMAN  
 304-558-2157**

VENDOR

RFQ COPY  
 TYPE NAME/ADDRESS HERE

SHIP TO

**DIV ENGINEERING & FACILITIES  
 NATIONAL GUARD ARMORY  
 ROUTE 4, SOUTH  
 BUCKHANNON, WV  
 26201 341-6368**

DATE PRINTED <b>07/19/2006</b>	TERMS OF SALE	SHIP VIA	F.O.B.	FREIGHT TERMS
-----------------------------------	---------------	----------	--------	---------------

BID OPENING DATE: **08/30/2006** BID OPENING TIME **01:30PM**

LINE	QUANTITY	UOP	CAT. NO.	ITEM NUMBER	UNIT PRICE	AMOUNT
<p>ANY OTHER SOURCE, VERBAL OR WRITTEN, WHICH CONTRADICTS OR ALTERS THE INFORMATION PROVIDED FROM THE SOURCES AS DESCRIBED IN THE ABOVE PARAGRAPH IS VOID AND OF NO EFFECT.</p> <p>BANKRUPTCY: IN THE EVENT THE VENDOR/CONTRACTOR FILES FOR BANKRUPTCY PROTECTION, THIS CONTRACT IS AUTOMATICALLY NULL AND VOID, AND IS TERMINATED WITHOUT FURTHER ORDER.</p> <p>REV. 1/2005</p> <p style="text-align: center;">NOTICE</p> <p>A SIGNED BID MUST BE SUBMITTED TO:</p> <p style="padding-left: 40px;">DEPARTMENT OF ADMINISTRATION          PURCHASING DIVISION          BUILDING 15          2019 WASHINGTON STREET, EAST          CHARLESTON, WV 25305-0130</p> <p>THE BID SHOULD CONTAIN THIS INFORMATION ON THE FACE OF THE ENVELOPE OR THE BID MAY NOT BE CONSIDERED:</p> <p>SEALED BID</p> <p>BUYER: CB-23</p> <p>REQ. NO.: DEFK7031</p> <p>BID OPENING DATE: 08/30/2006</p> <p>BID OPENING TIME: 1:30 PM</p>						

SEE REVERSE SIDE FOR TERMS AND CONDITIONS

SIGNATURE <i>Chuck Bowman</i>	TELEPHONE <b>304-345-5580</b>	DATE <b>8-25-06</b>
PROJECT NAME <i>Project 55-0243140</i>	FEIN <b>55-0243140</b>	ADDRESS CHANGES TO BE NOTED ABOVE

WHEN RESPONDING TO RFQ, INSERT NAME AND ADDRESS IN SPACE ABOVE LABELED 'VENDOR'



State of West Virginia  
 Department of Administration  
 Purchasing Division  
 2019 Washington Street East  
 Post Office Box 50130  
 Charleston, WV 25305-0130

# Request for Quotation

RFQ NUMBER  
**DEFK7031**

PAGE  
**10**

ADDRESS CORRESPONDENCE TO ATTENTION OF:  
**CHUCK BOWMAN**  
**304-558-2157**

VENDOR

RFQ COPY  
 TYPE NAME/ADDRESS HERE

SHIP TO

DIV ENGINEERING & FACILITIES  
 NATIONAL GUARD ARMORY  
 ROUTE 4, SOUTH  
 BUCKHANNON, WV  
 26201 341-6368

DATE PRINTED <b>07/19/2006</b>	TERMS OF SALE	SHIP VIA	F.O.B.	FREIGHT TERMS
-----------------------------------	---------------	----------	--------	---------------

BID OPENING DATE: **08/30/2006** BID OPENING TIME **01:30PM**

LINE	QUANTITY	UOP	CAT NO.	ITEM NUMBER	UNIT PRICE	AMOUNT
PLEASE PROVIDE A FAX NUMBER IN CASE IT IS NECESSARY TO CONTACT YOU REGARDING YOUR BID: <p style="text-align: center;">-----<b>304-345-5580</b>-----</p> PLEASE PRINT OR TYPE NAME OF PERSON TO CONTACT CONCERNING THIS QUOTE: <p style="text-align: center;">-----<b>GREG EDELMAN</b>-----</p> ***** THIS IS THE END OF RFQ DEFK7031 ***** TOTAL: _____						

SEE REVERSE SIDE FOR TERMS AND CONDITIONS

SIGNATURE <i>Greg Edelman</i>	TELEPHONE <b>304-345-5580</b>	DATE <b>8-25-06</b>
TITLE <i>Project Sales Mgr</i>	FEIN <b>55-0243140</b>	ADDRESS CHANGES TO BE NOTED ABOVE

WHEN RESPONDING TO RFQ, INSERT NAME AND ADDRESS IN SPACE ABOVE LABELED 'VENDOR'

**AFFIDAVIT**

043

**West Virginia Code §5A-3-10a states:**

No contract or renewal of any contract may be awarded by the state or any of its political subdivisions to any vendor or prospective vendor when the vendor or prospective vendor or a related party to the vendor or prospective vendor is a debtor and the debt owned is an amount greater than one thousand dollars in the aggregate.

**DEFINITIONS:**

"Debt" means any assessment, premium, penalty, fine, tax or other amount of money owed to the state or any of its political subdivisions because of a judgment, fine, permit violation, license assessment, defaulted workers' compensation premium, penalty or other assessment presently delinquent or due and required to be paid to the state or any of its political subdivisions, including any interest or additional penalties accrued thereon.

"Debtor" means any individual, corporation, partnership, association, limited liability company or any other form or business association owing a debt to the state or any of its political subdivisions.

"Political subdivision" means any county commission; municipality; county board of education; any instrumentality established by a county or municipality; any separate corporation or instrumentality established by one or more counties or municipalities, as permitted by law; or any public body charged by law with the performance of a government function or whose jurisdiction is coextensive with one or more counties or municipalities.

"Related party" means a party, whether an individual, corporation, partnership, association, limited liability company or any other form or business association or other entity whatsoever, related to any vendor by blood, marriage, ownership or contract through which the party has a relationship of ownership or other interest with the vendor so that the party will actually or by effect receive or control a portion of the benefit, profit or other consideration from performance of a vendor contract with the party receiving an amount that meets or exceeds five percent of the total contract amount.

**EXCEPTION:**

The prohibition of this section does not apply where a vendor has contested any tax administered pursuant to chapter eleven of this code, workers' compensation premium, permit fee or environmental fee or assessment and the matter has not become final or where the vendor has entered into a payment plan or agreement and the vendor is not in default of any of the provisions of such plan or agreement.

**LICENSING:**

The vendor must be licensed in accordance with any and all state requirements to do business with the state of West Virginia.

**CONFIDENTIALITY:**

The vendor agrees that he or she will not disclose to anyone, directly or indirectly, any such personally identifiable information or other confidential information gained from the agency, unless the individual who is the subject of the information consents to the disclosure in writing or the disclosure is made pursuant to the agency's policies, procedures and rules. Vendors should visit [www.state.wv.us/admin/purchase/privacy](http://www.state.wv.us/admin/purchase/privacy) for the Notice of Agency Confidentiality Policies.

Under penalty of law for false swearing (West Virginia Code, §61-5-3), it is hereby certified that the vendor acknowledges the information in this said affidavit and are in compliance with the requirements as stated.

Vendor's Name: H.E. NEUMANN Co.

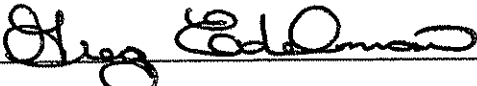
Authorized Signature:  Date: 8-28-06

BID BOND

011

KNOW ALL MEN BY THESE PRESENTS, That we, the undersigned, H.E. NEUMANN COMPANY  
of 2100 MIDDLE CREEK ROAD TRIADDELPHIA, WV 26059, as Principal, and OHIO FARMERS INSURANCE COMPANY  
of ONE PARK CIRCLE WESTFIELD CENTER, OH 44251, a corporation organized and existing under the laws of the State of  
OHIO with its principal office in the City of WESTFIELD CENTER, as Surety, are held and firmly bound unto the State  
of West Virginia, as Obligee, in the penal sum of FIVE PERCENT OF THE TOTAL AMOUNT BID (\$ 5%) for the payment of which,  
well and truly to be made, we jointly and severally bind ourselves, our heirs, administrators, executors, successors and assigns

The Condition of the above obligation is such that whereas the Principal has submitted to the Purchasing Section of the  
Department of Administration a certain bid or proposal, attached hereto and made a part hereof, to enter into a contract in writing for  
REPLACEMENT OF 8 TON UNIT - NATIONAL GUARD ARMORY - BUCKHANNON, WV

NOW THEREFORE,

- (a) If said bid shall be rejected, or
- (b) If said bid shall be accepted and the Principal shall enter into a contract in accordance with the bid or proposal attached  
hereto and shall furnish any other bonds and insurance required by the bid or proposal, and shall in all other respects perform the  
covenant created by the acceptance of said bid, then this obligation shall be null and void, otherwise this obligation shall remain in full  
force and effect. It is expressly understood and agreed that the liability of the Surety for any and all claims hereunder shall, in no event,  
exceed the penal amount of this obligation as herein stated.

The Surety, for the value received, hereby stipulates and agrees that the obligations of said Surety and its bond shall be in no  
wise impaired or affected by any extension of the time within which the Obligee may accept such bid, and said Surety does hereby  
give notice of any such extension

IN WITNESS WHEREOF, Principal and Surety have hereunto set their hands and seals, and such of them as are corporations  
have caused their corporate seals to be affixed hereunto and these presents to be signed by their proper officers, this  
30TH day of AUGUST, 2006.

Principal Corporate Seal

H.E. NEUMANN COMPANY  
(Name of Principal)  
By [Signature]  
(Must be President or  
Vice President)  
V.P.  
(Title)

Surety Corporate Seal

OHIO FARMERS INSURANCE COMPANY  
(Name of Surety)  
[Signature]  
Attorney-in-Fact  
NICHOLAS A. SPARACHANE

WARRANT - Surety executing bonds must be licensed in West Virginia to transact surety insurance. Corporate seals must be affixed.  
Signature of attorney must be attached

General  
Power  
of Attorney

**Westfield Insurance Co.**  
**Westfield National Insurance Co.**  
**Ohio Farmers Insurance Co.**  
Westfield Center, Ohio

CERTIFIED COPY

Know All Men by These Presents, That WESTFIELD INSURANCE COMPANY, WESTFIELD NATIONAL INSURANCE COMPANY and OHIO FARMERS INSURANCE COMPANY, corporations, hereinafter referred to individually as a "Company" and collectively as "Companies," duly organized and existing under the laws of the State of Ohio, and having its principal office in Westfield Center, Medina County, Ohio, do by these presents make, constitute and appoint  
**PAUL R. TURNER, NICHOLAS A. SPARACHANE, ANNETTE L. LAWRENCE, JOINTLY OR SEVERALLY**

of WHEELING and State of WV its true and lawful Attorney(s)-in-Fact, with full power and authority hereby conferred in its name, place and stead, to execute, acknowledge and deliver any and all bonds, recognizances, undertakings, or other instruments or contracts of suretyship-

**LIMITATION: THIS POWER OF ATTORNEY CANNOT BE USED TO EXECUTE NOTE GUARANTEE, MORTGAGE DEFICIENCY, MORTGAGE GUARANTEE, OR BANK DEPOSITORY BONDS.**

and to bind any of the Companies thereby as fully and to the same extent as if such bonds were signed by the President, sealed with the corporate seal of the applicable Company and duly attested by its Secretary, hereby ratifying and confirming all that the said Attorney(s)-in-Fact may do in the premises. Said appointment is made under and by authority of the following resolution adopted by the Board of Directors of each of the WESTFIELD INSURANCE COMPANY, WESTFIELD NATIONAL INSURANCE COMPANY and OHIO FARMERS INSURANCE COMPANY:

"Be It Resolved, that the President, any Senior Executive, any Secretary or any Fidelity & Surety Operations Executive or other Executive shall be and is hereby vested with full power and authority to appoint any one or more suitable persons as Attorney(s)-in-Fact to represent and act for and on behalf of the Company subject to the following provisions:

The Attorney-in-Fact may be given full power and authority for and in the name of and on behalf of the Company, to execute, acknowledge and deliver, any and all bonds, recognizances, contracts, agreements of indemnity and other conditional or obligatory undertakings and any and all notices and documents canceling or terminating the Company's liability thereunder, and any such instruments so executed by any such Attorney-in-Fact shall be as binding upon the Company as if signed by the President and sealed and attested by the Corporate Secretary."

"Be it Further Resolved, that the signature of any such designated person and the seal of the Company heretofore or hereafter affixed to any power of attorney or any certificate relating thereto by facsimile, and any power of attorney or certificate bearing facsimile signatures or facsimile seal shall be valid and binding upon the Company with respect to any bond or undertaking to which it is attached." (Each adopted at a meeting held on February 8, 2000).

In Witness Whereof, WESTFIELD INSURANCE COMPANY, WESTFIELD NATIONAL INSURANCE COMPANY and OHIO FARMERS INSURANCE COMPANY have caused these presents to be signed by their Senior Executive and their corporate seals to be hereto affixed this 19th day of FEBRUARY A.D., 2004 .

Corporate  
Seals  
Affixed



WESTFIELD INSURANCE COMPANY  
WESTFIELD NATIONAL INSURANCE COMPANY  
OHIO FARMERS INSURANCE COMPANY

By:  
Richard L. Kinnaird, Jr., Senior Executive

State of Ohio  
County of Medina ss.:

On this 19th day of FEBRUARY A.D., 2004 , before me personally came Richard L. Kinnaird, Jr. to me known, who, being by me duly sworn, did depose and say, that he resides in Medina, Ohio; that he is Senior Executive of WESTFIELD INSURANCE COMPANY, WESTFIELD NATIONAL INSURANCE COMPANY and OHIO FARMERS INSURANCE COMPANY, the companies described in and which executed the above instrument; that he knows the seals of said Companies; that the seals affixed to said instrument are such corporate seals; that they were so affixed by order of the Boards of Directors of said Companies; and that he signed his name thereto by like order.

Notarial  
Seal  
Affixed



William J. Kahelin, Attorney at Law, Notary Public  
My Commission Does Not Expire (Sec. 147.03 Ohio Revised Code)

State of Ohio  
County of Medina ss.:

I, M. Brooks Rorapaugh, Secretary of WESTFIELD INSURANCE COMPANY, WESTFIELD NATIONAL INSURANCE COMPANY and OHIO FARMERS INSURANCE COMPANY, do hereby certify that the above and foregoing is a true and correct copy of a Power of Attorney, executed by said Companies, which is still in full force and effect; and furthermore, the resolutions of the Boards of Directors, set out in the Power of Attorney are in full force and effect.

In Witness Whereof, I have hereunto set my hand and affixed the seals of said Companies at Westfield Center, Ohio, this 30th day of AUGUST A.D., 2006



M. Brooks Rorapaugh, Secretary



State of West Virginia  
 Department of Administration  
 Purchasing Division  
 2019 Washington Street East  
 Post Office Box 50130  
 Charleston, WV 25305-0130

# Request for Quotation

RFQ NUMBER  
 DEFK7031

PAGE  
 1

ADDRESS CORRESPONDENCE TO ATTENTION OF  
 CHUCK BOWMAN  
 304-558-2157

\*709035106 01 304-345-5580  
 H E NEUMANN CO  
 1410 SIXTH AVENUE  
 CHARLESTON WV 25312

VENDOR

SHIP TO

DIV ENGINEERING & FACILITIES  
 NATIONAL GUARD ARMORY  
 ROUTE 4, SOUTH  
 BUCKHANNON, WV  
 26201 341-6368

DATE PRINTED	TERMS OF SALE	SHIP VIA	F.O.B.	FREIGHT TERMS
08/11/2006				

BID OPENING DATE: 08/30/2006 BID OPENING TIME 01:30PM

LINE	QUANTITY	UOP	CAT NO.	ITEM NUMBER	UNIT PRICE	AMOUNT
0001	1	JB		031-06		
<p>***** ADDENDUM NO.1 *****</p> <p>ADDENDUM ISSUED TO DISTRIBUTE THE PRE-BID SIGN-IN SHEET AND THE COMMENTS FROM THE AGENCY AS A RESULT OF THE PRE-BID MEETING FOR THE HVAC SYSTEM REPLACEMENT AT THE BUCKHANNON ARMORY IN BUCKHANNON, WV.</p> <p>PLEASE SEE THE ATTACHED TWO (2) PAGES.</p> <p>BID DATE AND OPENING TIME REMAIN UNCHANGED AS 08/30/06 AT 1:30 PM.</p> <p>***** NO OTHER CHANGES *****</p>						
AIR CONDITIONING AND HEATING, CENTRAL UNITS						

SEE REVERSE SIDE FOR TERMS AND CONDITIONS

SIGNATURE <i>Chas Ed Bowman</i>	TELEPHONE 304-345-5580	DATE 8-25-06
TITLE	FEIN 55-023140	ADDRESS CHANGES TO BE NOTED ABOVE

WHEN RESPONDING TO RFQ, INSERT NAME AND ADDRESS IN SPACE ABOVE LABELED 'VENDOR'

**GENERAL TERMS & CONDITIONS  
REQUEST FOR QUOTATION (RFQ) AND REQUEST FOR PROPOSAL (RFP)**

1. Awards will be made in the best interest of the State of West Virginia.
2. The State may accept or reject in part, or in whole, any bid.
3. All quotations are governed by the *West Virginia Code* and the *Legislative Rules* of the Purchasing Division.
4. Prior to any award, the apparent successful vendor must be properly registered with the Purchasing Division and have paid the required \$125.00 registration fee.
5. All services performed or goods delivered under State Purchase Orders/Contracts are to be continued for the term of the Purchase Order/Contract, contingent upon funds being appropriated by the Legislature or otherwise being made available. In the event funds are not appropriated or otherwise available for these services or goods, this Purchase Order/Contract becomes void and of no effect after June 30.
6. Payment may only be made after the delivery and acceptance of goods or services.
7. Interest may be paid for late payment in accordance with the *West Virginia Code*.
8. Vendor preference will be granted upon written request in accordance with the *West Virginia Code*.
9. The State of West Virginia is exempt from federal and state taxes and will not pay or reimburse such taxes.
10. The Director of Purchasing may cancel any Purchase Order/Contract upon 30 days written notice to the seller.
11. The laws of the State of West Virginia and the *Legislative Rules* of the Purchasing Division shall govern all rights and duties under the Contract, including without limitation the validity of this Purchase Order/Contract.
12. Any reference to automatic renewal is hereby deleted. The Contract may be renewed only upon mutual written agreement of the parties.
13. **BANKRUPTCY:** In the event the vendor/contractor files for bankruptcy protection, this contract is automatically null and void, and is terminated without further order.
14. **HIPAA Business Associate Addendum** - The West Virginia State Government HIPAA Business Associate Addendum (BAA), approved by the Attorney General, and available online at the Purchasing Division's web site (<http://www.state.wv.us/admin/purchase/vrc/hipaa.htm>) is hereby made part of the agreement. Provided that, the Agency meets the definition of a Covered Entity (45 CFR §160.103) and will be disclosing Protected Health Information (45 CFR §160.103) to the vendor.

---

**INSTRUCTIONS TO BIDDERS**

1. Use the quotation forms provided by the Purchasing Division.
2. **SPECIFICATIONS:** Items offered must be in compliance with the specifications. Any deviation from the specifications must be clearly indicated by the bidder. Alternates offered by the bidder as **EQUAL** to the specifications must be clearly defined. A bidder offering an alternate should attach complete specifications and literature to the bid. The Purchasing Division may waive minor deviations to specifications.
3. Complete all sections of the quotation form.
4. Unit prices shall prevail in cases of discrepancy.
5. All quotations are considered F.O.B. destination unless alternate shipping terms are clearly identified in the quotation.
6. **BID SUBMISSION:** All quotations must be delivered by the bidder to the office listed below prior to the date and time of the bid opening. Failure of the bidder to deliver the quotations on time will result in bid disqualifications.

**SIGNED BID TO:**

Department of Administration  
Purchasing Division  
2019 Washington Street East  
Post Office Box 50130  
Charleston, WV 25305-0130





002

OFFICE OF THE ADJUTANT GENERAL  
**DIVISION OF ENGINEERING AND FACILITIES**  
1707 COONSKIN DRIVE  
CHARLESTON, WEST VIRGINIA 25311-1099  
(304) 561-6333

Allen E. Tackett  
Major General, WVARNG  
The Adjutant General

Michael J. Beckner  
Captain, WVARNG  
Armory Facilities Manager

August 9, 2006

DEFK7031

ADDENDUM #1

1. The installed unit manufacturer will be Liebert, Data Aire or equal, will be an R-22 system with air cooled condenser, will have two independent stages of cooling, and be equipped with smoke detector.
2. Delete Alternate # 1 from the bid.
3. Installation will be coordinated with on site maintenance personnel and once the existing unit is disabled the contractor will work consecutive days until the new unit is operational.
4. The contractor will have 45 days from " Notice to Proceed" to complete the project.

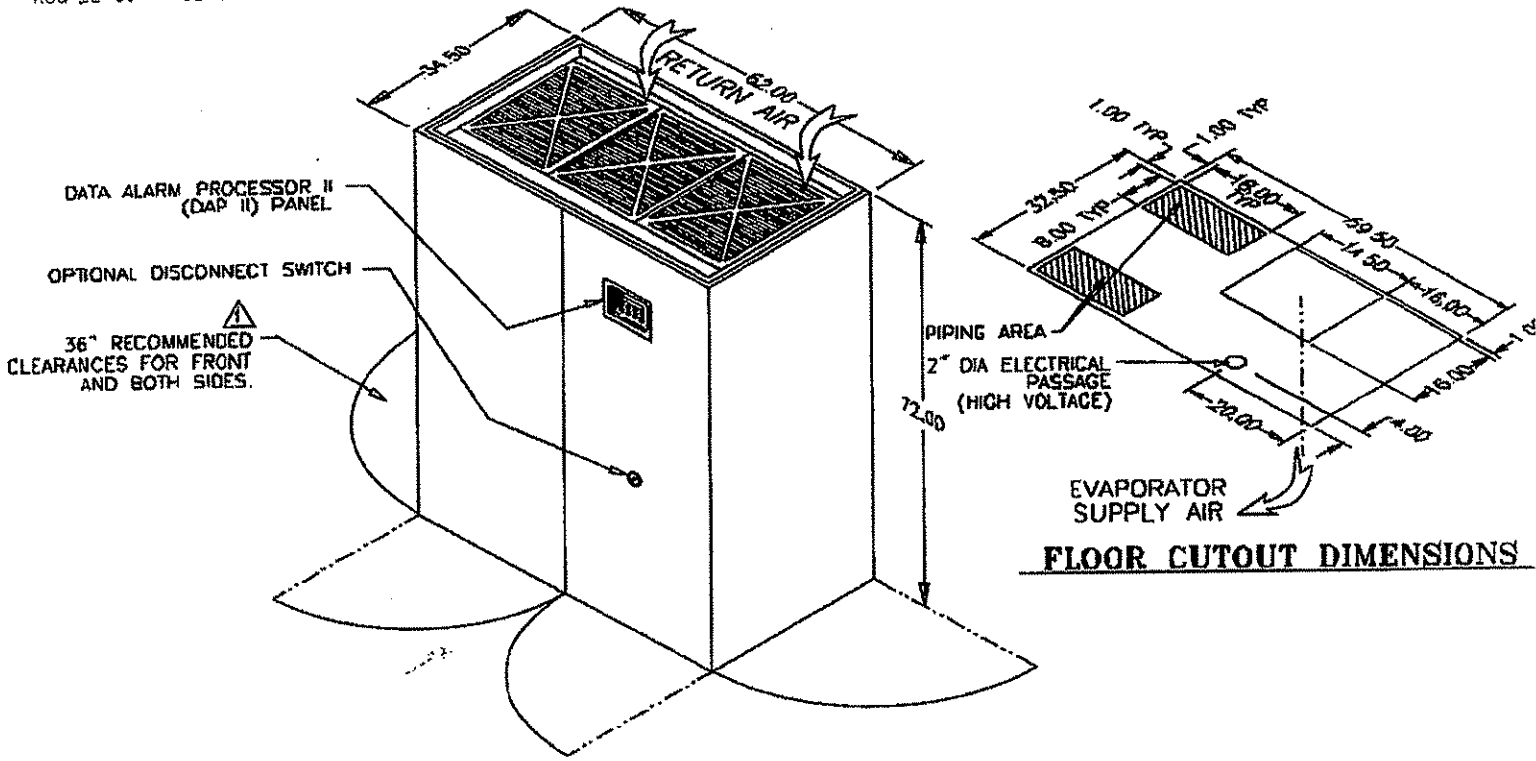

**DIMENSIONAL DATA**

**NOTES:**

- 1. DIMENSIONS NOTED ARE THE MINIMUM CLEARANCES REQUIRED BY THE FACTORY. CONSULT LOCAL BUILDING CODES AND NEC FOR ADDITIONAL CLEARANCE REQUIREMENTS.
- 2. ALL REFRIGERATION PIPING TERMINATES INSIDE CABINET
- 3. ALL COMPONENTS AND OPTIONS ARE NOT SHOWN.

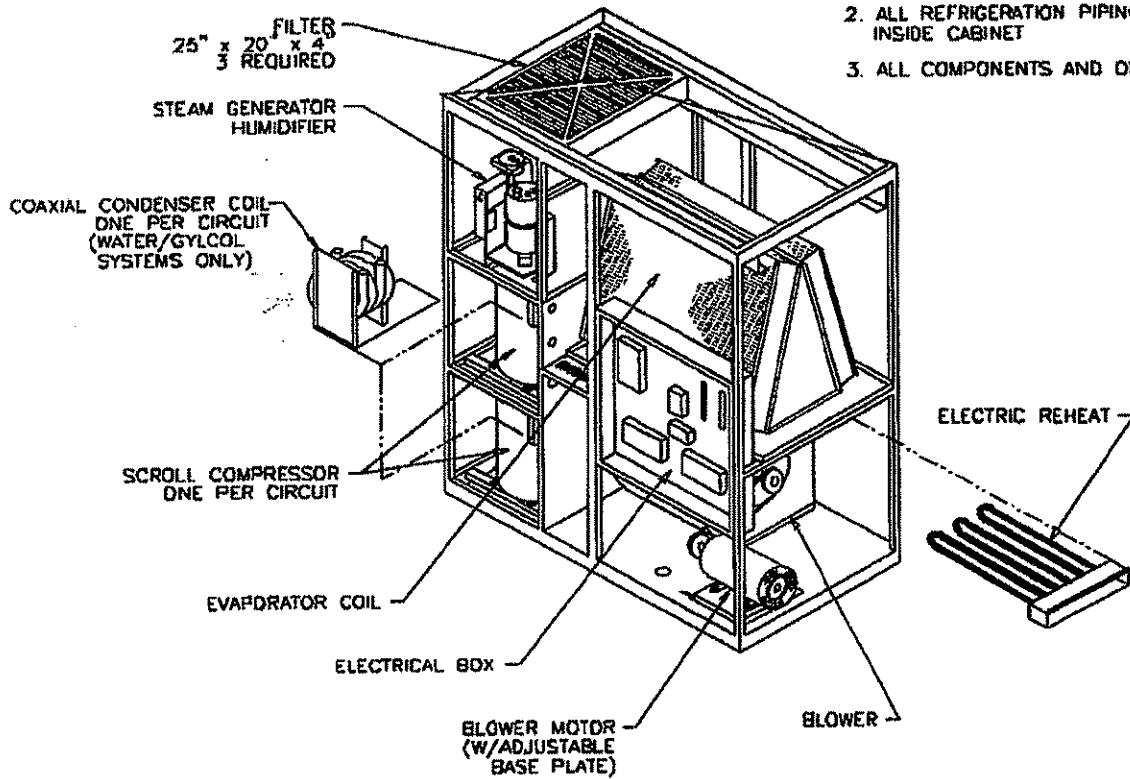

**COMPONENT BREAKDOWN**

**DAI** Data Aire Inc.  
 230 W. BlueRidge Avenue  
 Orange, CA 92865-4225  
 Phone: 800/ 347-2473 • Fax: 714/ 921-6010

**Data Aire Series DX**  
 6, 8, 10 Ton Downflow

**DATA AIRE Air Cooled Condensers, DARC 06-50, Dual Circuit**

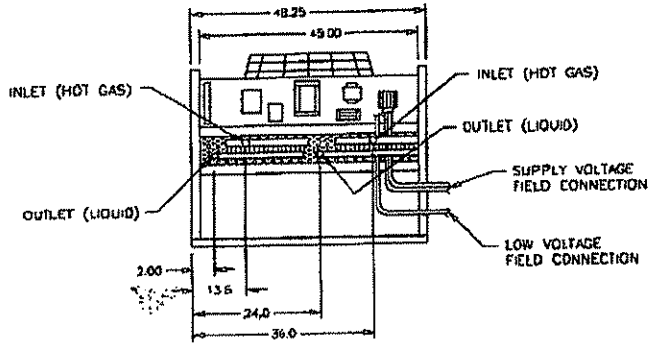

DUAL CIRCUIT CONNECTION LOCATION

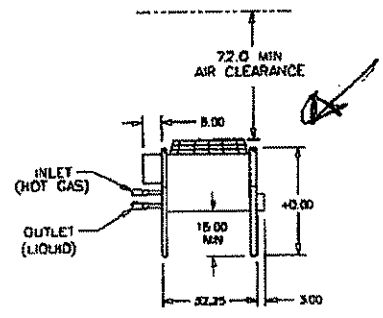

1 FAN UNIT, MODEL 6 THRU 9

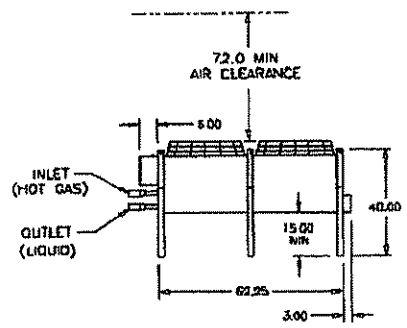

2 FAN UNIT, MODEL 11 THRU 17

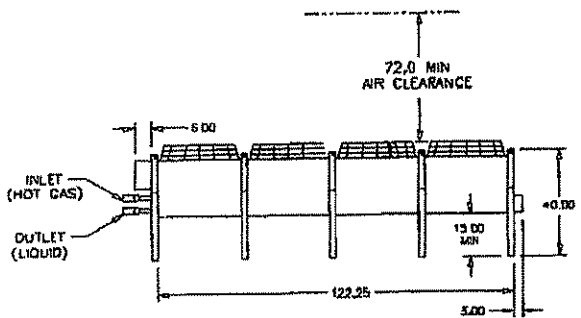

4 FAN UNIT, MODEL 30 THRU 40

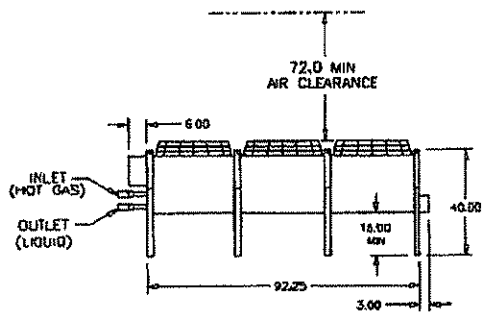

3 FAN UNIT, MODEL 21 THRU 28

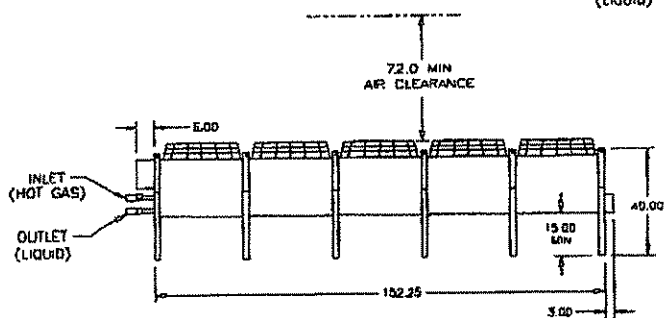

5 FAN UNIT, MODEL 44 THRU 50

**DATA AIRE Air Cooled Condensers, DARC 06-50, Dual Circuit**

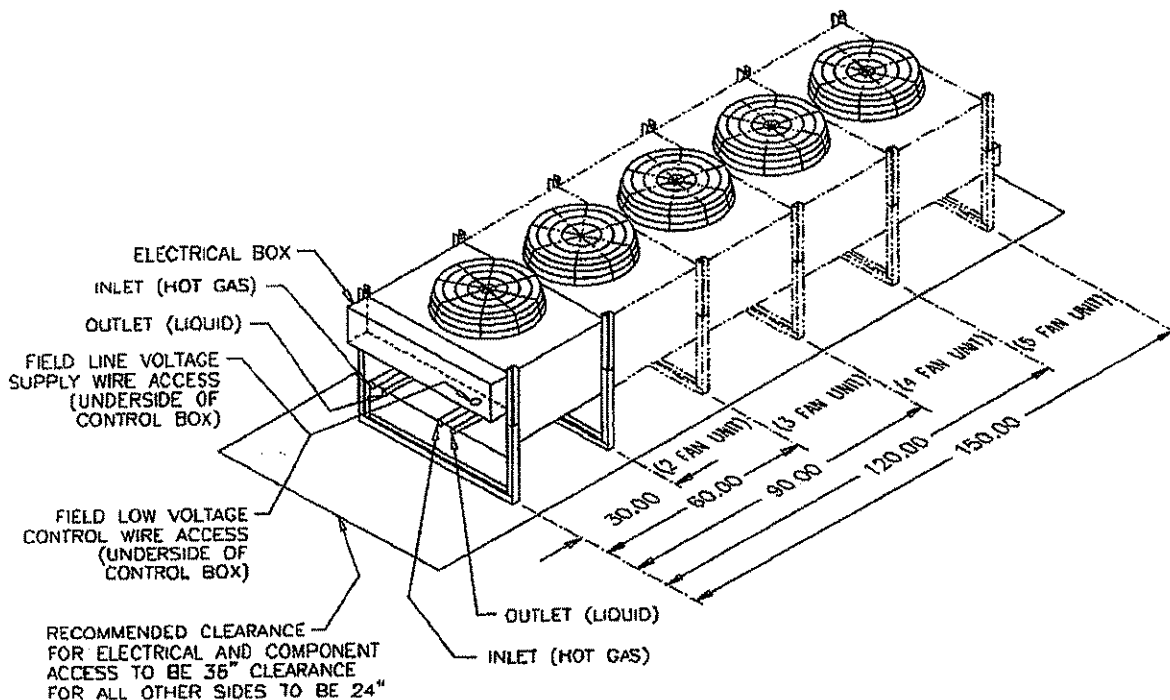

MODEL NUMBER	LENGTH	UNIT NET WT #	PIPE CONNECTION SIZES (COPPER STUDS)		QTY. MOTORS	STANDARD CONDENSER				LOW DECIBEL CONDENSER					
			HOT GAS	LIQUID		H.P.	RPM	TOTAL CFM	MOTOR FLA		H.P.	RPM	TOTAL CFM	MOTOR FLA	
									208/230V	460V				208/230V	460V
DARC 06	32-1/4"	220	1-1/8	7/8	1	3/4	1075	5000	4.2	2.1	1/2	850	4000	3.2	1.6
DARC 07	32-1/4"	250	1-1/8	7/8	1	3/4	1075	4900	4.2	2.1	1/2	850	3900	3.2	1.6
DARC 09	32-1/4"	270	1-1/8	7/8	1	3/4	1075	4800	4.2	2.1	1/2	850	3800	3.2	1.6
DARC 11	62-1/4"	300	1-1/8	7/8	2	3/4	1075	10400	8.4	4.2	1/2	850	8300	6.4	3.2
DARC 15	62-1/4"	310	1-1/8	7/8	2	3/4	1075	10000	8.4	4.2	1/2	850	8000	6.4	3.2
DARC 17	62-1/4"	320	1-3/8	7/8	2	3/4	1075	9800	8.4	4.2	1/2	850	7800	6.4	3.2
DARC 21	92-1/4"	450	1-1/8	7/8	3	3/4	1075	15000	12.6	6.3	1/2	850	12000	9.6	4.8
DARC 24	92-1/4"	520	1-3/8	7/8	3	3/4	1075	14750	12.6	6.3	1/2	850	11800	9.6	4.8
DARC 28	92-1/4"	530	1-3/8	7/8	3	3/4	1075	14500	12.6	6.3	1/2	850	11600	9.6	4.8
DARC 30	122-1/4"	610	1-3/8	7/8	4	3/4	1075	20000	16.8	8.4	1/2	850	16000	12.8	6.4
DARC 37	122-1/4"	700	1-5/8	1-1/8	4	3/4	1075	19500	16.8	8.4	1/2	850	15600	12.8	6.4
DARC 40	122-1/4"	920	1-5/8	1-1/8	4	3/4	1075	19000	16.8	8.4	1/2	850	15200	12.8	6.4
DARC 44	152-1/4"	1270	1-5/8	1-1/8	5	3/4	1075	24500	21.0	10.5	1/2	850	19800	16.0	8.0
DARC 50	152-1/4"	1360	1-5/8	1-1/8	5	3/4	1075	24000	21.0	10.5	1/2	850	19200	16.0	8.0