



State of West Virginia
Department of Administration
Purchasing Division
2019 Washington Street East
Post Office Box 50130
Charleston, WV 25305-0130

Request for Quotation

RFQ NUMBER
COR61340

PAGE
1

ADDRESS: CORRESPONDENCE TO ATTENTION OF:
**JOHN ABBOTT
304-558-2544**

VENDOR

RFQ COPY
TYPE NAME/ADDRESS HERE

Elco Mech

SHIP TO

**DIVISION OF CORRECTIONS
617 LEON SULLIVAN WAY
CHARLESTON, WV
25301 304-558-8045**

| | | | | |
|-------------------------------------|---------------|---------------------------------|--------|---------------|
| DATE PRINTED 02/22/2007 | TERMS OF SALE | SHIP VIA | F.O.B. | FREIGHT TERMS |
| BID OPENING DATE: 03/21/2007 | | BID OPENING TIME 01:30PM | | |

| LINE | QUANTITY | UOP | CAT NO. | ITEM NUMBER | UNIT PRICE | AMOUNT |
|--|----------|-----|---------|-------------|------------|---------------------|
| REQUEST FOR QUOTATION | | | | | | |
| THE PURCHASING DIVISION IS SOLICITING BIDS FOR THE DIVISION OF CORRECTIONS TO PROVIDE THE INSTALLATION OF HEATING AND COOLING UNITS; AND THE REMOVAL AND DISPOSAL OF THE OLD UNITS. | | | | | | |
| MANDATORY ON-SITE PRE-BID: 03/07/2007; 2:00 PM. PRE-REGISTRATION IS REQUIRED BY CONTACTING TIM WHITTINGTON AT (304) 442-7214; BY 3/5/2007. | | | | | | |
| ATTACHMENTS: 1. SPECIFICATIONS 2. AFFIDAVIT | | | | | | |
| 0001 | 1 | LS | | 031-06 | | <i>\$259,000.00</i> |
| HEATING/COOLING UNIT INSTALLATION | | | | | | |
| EXHIBIT 5 | | | | | | |
| NOTICE TO PROCEED: THIS CONTRACT IS TO BE PERFORMED WITHIN 45 CALENDAR DAYS AFTER THE NOTICE TO PROCEED IS RECEIVED. UNLESS OTHERWISE SPECIFIED, THE FULLY EXECUTED PURCHASE ORDER WILL BE CONSIDERED NOTICE TO PROCEED. | | | | | | |
| CANCELLATION: THE DIRECTOR OF PURCHASING RESERVES THE RIGHT TO CANCEL THIS CONTRACT IMMEDIATELY UPON WRITTEN NOTICE TO THE VENDOR IF THE MATERIALS OR WORKMANSHIP SUPPLIED ARE OF AN INFERIOR QUALITY OR DO NOT CONFORM | | | | | | |

RECEIVED
2007 MAR 21 A 9:50
PURCHASING DIVISION
STATE OF WV

SEE REVERSE SIDE FOR TERMS AND CONDITIONS

| | | |
|---------------------------------|---------------------------------|-----------------------------------|
| SIGNATURE <i>Ronald Y...</i> | TELEPHONE 304-3460546 | DATE 03/21/2007 |
| TITLE Vice President | FEIN 55-053-4807 | ADDRESS CHANGES TO BE NOTED ABOVE |

WHEN RESPONDING TO RFQ, INSERT NAME AND ADDRESS IN SPACE ABOVE LABELED 'VENDOR'



State of West Virginia
 Department of Administration
 Purchasing Division
 2019 Washington Street East
 Post Office Box 50130
 Charleston, WV 25305-0130

Request for Quotation

RFQ NUMBER
COR61340

PAGE
2

ADDRESS CORRESPONDENCE TO ATTENTION OF
JOHN ABBOTT
304-558-2544

VENDOR

RFQ COPY
 TYPE NAME/ADDRESS HERE

SHIP TO

DIVISION OF CORRECTIONS
617 LEON SULLIVAN WAY
CHARLESTON, WV
25301 **304-558-8045**

| DATE PRINTED | TERMS OF SALE | SHIP VIA | F.O.B. | FREIGHT TERMS |
|--------------|---------------|----------|--------|---------------|
| 02/22/2007 | | | | |

BID OPENING DATE: **03/21/2007** BID OPENING TIME **01:30PM**

| LINE | QUANTITY | UOP | CAT NO. | ITEM NUMBER | UNIT PRICE | AMOUNT |
|--|----------|-----|---------|-------------|------------|--------|
| <p>WITH THE SPECIFICATIONS OF THE BID AND CONTRACT HERE IN.</p> <p>WAGE RATES: THE CONTRACTOR OR SUBCONTRACTOR SHALL PAY THE HIGHER OF THE U.S. DEPARTMENT OF LABOR MINIMUM WAGE RATES AS ESTABLISHED FOR FAYETTE COUNTY, PURSUANT TO WEST VIRGINIA CODE 21-5A, ET, SEQ. (PREVAILING WAGE RATES APPLY TO THIS PROJECT)</p> <p>ARBITRATION: ANY REFERENCES MADE TO ARBITRATION OR INTEREST FOR PAYMENTS DUE (EXCEPT FOR ANY INTEREST REQUIRED BY STATE LAW) CONTAINED IN THIS CONTRACT OR IN ANY AMERICAN INSTITUTE OF ARCHITECTS DOCUMENTS PERTAINING TO THIS CONTRACT ARE HEREBY DELETED.</p> <p>WORKERS' COMPENSATION: VENDOR IS REQUIRED TO PROVIDE A CERTIFICATE FROM WORKERS' COMPENSATION IF SUCCESSFUL.</p> <p>ALL OF THE ITEMS CHECKED BELOW WILL BE A REQUIREMENT OF THIS CONTRACT:</p> <p>(XX) INSURANCE: SUCCESSFUL VENDOR SHALL FURNISH PROOF OF COMMERCIAL GENERAL LIABILITY INSURANCE PRIOR TO ISSUANCE OF CONTRACT. UNLESS OTHERWISE SPECIFIED IN THE BID DOCUMENTS, THE MINIMUM AMOUNT OF INSURANCE COVERAGE REQUIRED IS \$250,000.</p> <p>() BUILDERS RISK INSURANCE: SUCCESSFUL VENDOR SHALL FURNISH PROOF OF BUILDERS RISK - ALL RISK INSURANCE IN AN AMOUNT EQUAL TO 100% OF THE AMOUNT OF THE CONTRACT.</p> <p>(XX) BONDS: FIVE PERCENT (5%) OF THE TOTAL AMOUNT OF THE BID PAYABLE TO THE STATE OF WEST VIRGINIA, SHALL BE SUBMITTED WITH EACH BID AS A BID BOND. THE SUCCESSFUL BIDDER SHALL ALSO FURNISH A PERFORMANCE BOND AND LABOR/MATERIAL BOND FOR 100% OF THE AMOUNT OF THE CONTRACT.</p> | | | | | | |

SEE REVERSE SIDE FOR TERMS AND CONDITIONS

| | | |
|-----------|-----------|------|
| SIGNATURE | TELEPHONE | DATE |
|-----------|-----------|------|

| | | |
|-------|------|-----------------------------------|
| TITLE | FEIN | ADDRESS CHANGES TO BE NOTED ABOVE |
|-------|------|-----------------------------------|

WHEN RESPONDING TO RFQ, INSERT NAME AND ADDRESS IN SPACE ABOVE LABELED 'VENDOR'



State of West Virginia
 Department of Administration
 Purchasing Division
 2019 Washington Street East
 Post Office Box 50130
 Charleston, WV 25305-0130

Request for Quotation

RFQ NUMBER
COR61340

PAGE
3

ADDRESS CORRESPONDENCE TO ATTENTION OF
**JOHN ABBOTT
 304-558-2544**

VENDOR

RFQ COPY
 TYPE NAME/ADDRESS HERE

SHIP TO

**DIVISION OF CORRECTIONS
 617 LEON SULLIVAN WAY
 CHARLESTON, WV
 25301 304-558-8045**

| DATE PRINTED | TERMS OF SALE | SHIP VIA | F.O.B. | FREIGHT TERMS |
|--------------|---------------|----------|--------|---------------|
| 02/22/2007 | | | | |

BID OPENING DATE: **03/21/2007** BID OPENING TIME **01:30PM**

| LINE | QUANTITY | UOP | CAT NO. | ITEM NUMBER | UNIT PRICE | AMOUNT |
|--|----------|-----|---------|-------------|------------|--------|
| | | | | | | |
| <p>BONDS MAY BE PROVIDED IN THE FORM OF A CERTIFIED CHECK, IRREVOCABLE LETTER OF CREDIT, OR BOND FURNISHED BY A SOLVENT SURETY COMPANY AUTHORIZED TO DO BUSINESS IN THE STATE OF WEST VIRGINIA. A LETTER OF CREDIT SUBMITTED IN LIEU OF A PERFORMANCE AND LABOR & MATERIAL BOND WILL ONLY BE ALLOWED FOR PROJECTS UNDER \$100,000. PERSONAL OR BUSINESS CHECKS ARE NOT ACCEPTABLE IN LIEU OF THE 5% BID BOND, PERFORMANCE BOND, OR LABOR AND MATERIAL BOND.</p> <p>(XX) MAINTENANCE BOND: A TWO (2) YEAR MAINTENANCE BOND COVERING THE ROOFING SYSTEM WILL BE A REQUIREMENT OF THE SUCCESSFUL VENDOR.</p> <p>REV. 11/00</p> <p>EXHIBIT 7</p> <p>DOMESTIC ALUMINUM, GLASS & STEEL IN PUBLIC WORKS PROJECTS</p> <p>IN ACCORDANCE WITH WEST VIRGINIA CODE 5-19-1 ET., SEQ., EVERY CONTRACT FOR CONSTRUCTION, RECONSTRUCTION, ALTERATION, REPAIR, IMPROVEMENT OR MAINTENANCE OF PUBLIC WORKS, WHERE THE COST IS MORE THAN \$50,000 AND, IN THE CASE OF STEEL ONLY, WHERE THE COST OF STEEL IS MORE THAN \$50,000 OR WHERE MORE THAN 10,000 POUNDS OF STEEL ARE REQUIRED, THE STATE WILL ACCEPT ONLY ALUMINUM GLASS, OR STEEL PRODUCTS PRODUCED IN THE UNITED STATES IN ADDITION, ITEMS OF MACHINERY OR EQUIPMENT PURCHASED FOR USE AT THE SITE OF PUBLIC WORKS SHALL BE MADE OF DOMESTIC ALUMINUM, GLASS OR STEEL, UNLESS THE COST OF THE PRODUCT IS LESS THAN \$50,000 OR LESS THAN 10,000 POUNDS OF STEEL ARE USED IN PUBLIC WORKS PROJECTS.</p> | | | | | | |

SEE REVERSE SIDE FOR TERMS AND CONDITIONS

| | | |
|-----------|-----------|-----------------------------------|
| SIGNATURE | TELEPHONE | DATE |
| TITLE | FEIN | ADDRESS CHANGES TO BE NOTED ABOVE |

WHEN RESPONDING TO RFQ, INSERT NAME AND ADDRESS IN SPACE ABOVE LABELED 'VENDOR'



State of West Virginia
 Department of Administration
 Purchasing Division
 2019 Washington Street East
 Post Office Box 50130
 Charleston, WV 25305-0130

Request for Quotation

RFQ NUMBER
COR61340

PAGE
4

ADDRESS CORRESPONDENCE TO ATTENTION OF
JOHN ABBOTT
304-558-2544

VENDOR

RFQ COPY
 TYPE NAME/ADDRESS HERE

SHIP TO

DIVISION OF CORRECTIONS
 617 LEON SULLIVAN WAY
 CHARLESTON, WV
 25301 304-558-8045

| DATE PRINTED | TERMS OF SALE | SHIP VIA | F.O.B. | FREIGHT TERMS |
|--------------|---------------|----------|--------|---------------|
| 02/22/2007 | | | | |

BID OPENING DATE: **03/21/2007** BID OPENING TIME **01:30PM**

| LINE | QUANTITY | UOP | CAT NO | ITEM NUMBER | UNIT PRICE | AMOUNT |
|---|----------|-----|--------|-------------|------------|--------|
| | | | | | | |
| <p>FOREIGN MADE ALUMINUM, GLASS OR STEEL PRODUCTS MAY BE ACCEPTED ONLY IF THE COST OF DOMESTIC PRODUCTS IS FOUND TO BE UNREASONABLE. SUCH COST IS UNREASONABLE IF IT IS 20% OR MORE HIGHER THAN THE BID PRICE FOR FOREIGN MADE PRODUCTS. IF THE DOMESTIC ALUMINUM, GLASS OR STEEL PRODUCTS TO BE SUPPLIED OR PRODUCED IN A "SUBSTANTIAL LABOR SURPLUS AREA", AS DEFINED BY THE UNITED STATES DEPARTMENT OF LABOR, FOREIGN PRODUCTS MAY BE SUPPLIED ONLY IF DOMESTIC PRODUCTS ARE 30% OR MORE HIGHER IN PRICE THAN THE FOREIGN MADE PRODUCTS.</p> <p>IF, PRIOR TO THE AWARD OF A CONTRACT UNDER THE ABOVE PROVISIONS, THE SPENDING OFFICER OF THE SPENDING UNIT DETERMINES THAT THERE EXISTS A BID FOR LIKE FOREIGN ALUMINUM, GLASS OR STEEL THAT IS REASONABLE AND LOWER THAN THE LOWEST BID DOMESTIC PRODUCTS, THE SPENDING OFFICE MAY REQUEST, IN WRITING, A REEVALUATION AND REDUCTION IN THE LOWEST BID FOR SUCH DOMESTIC PRODUCTS ALL VENDORS MUST INDICATE IN THEIR BID IF THEY ARE SUPPLYING FOREIGN ALUMINUM, GLASS OR STEEL.</p> <p>REV. 3/88</p> <p>EXHIBIT 9</p> <p>NOTICE FOR ISSUANCE & ACKNOWLEDGEMENT OF CONSTRUCTION PROJECT ADDENDA</p> <p>THE ARCHITECT/ENGINEER AND/OR AGENCY SHALL BE REQUIRED TO ABIDE BY THE FOLLOWING SCHEDULE IN ISSUING CONSTRUCTION PROJECT ADDENDA FOR STATE AGENCIES:</p> <p>(1) THE ARCHITECT/ENGINEER SHALL PREPARE THE ADDENDUM AND A LIST OF ALL PARTIES THAT HAVE PROCURED DRAWINGS AND SPECIFICATIONS FOR THE PROJECT. THE ADDENDUM</p> | | | | | | |

SEE REVERSE SIDE FOR TERMS AND CONDITIONS

| | | | |
|-----------|------|-----------------------------------|------|
| SIGNATURE | | TELEPHONE | DATE |
| TITLE | FEIN | ADDRESS CHANGES TO BE NOTED ABOVE | |

WHEN RESPONDING TO RFQ, INSERT NAME AND ADDRESS IN SPACE ABOVE LABELED 'VENDOR'



State of West Virginia
 Department of Administration
 Purchasing Division
 2019 Washington Street East
 Post Office Box 50130
 Charleston, WV 25305-0130

Request for Quotation

RFQ NUMBER
COR61340

PAGE
5

ADDRESS CORRESPONDENCE TO ATTENTION OF
JOHN ABBOTT
304-558-2544

VENDOR

RFQ COPY
 TYPE NAME/ADDRESS HERE

SHIP TO

DIVISION OF CORRECTIONS
617 LEON SULLIVAN WAY
CHARLESTON, WV
25301 304-558-8045

| DATE PRINTED | TERMS OF SALE | SHIP VIA | F.O.B. | FREIGHT TERMS |
|--------------|---------------|----------|--------|---------------|
| 02/22/2007 | | | | |

BID OPENING DATE: **03/21/2007** BID OPENING TIME **01:30PM**

| LINE | QUANTITY | UOP | CAT NO | ITEM NUMBER | UNIT PRICE | AMOUNT |
|---|----------|-----|--------|-------------|------------|--------|
| <p>AND LIST SHALL BE FORWARDED TO THE BUYER IN THE STATE PURCHASING DIVISION. THE ARCHITECT/ENGINEER SHALL ALSO SEND A COPY OF THE ADDENDUM TO THE STATE AGENCY FOR WHICH THE CONTRACT IS ISSUED.</p> <p>(2) THE BUYER SHALL SEND THE ADDENDUM TO ALL INTERESTED PARTIES AND, IF NECESSARY, EXTEND THE BID OPENING DATE. ANY ADDENDUM SHOULD BE RECEIVED BY THE BUYER WITHIN FOURTEEN (14) DAYS PRIOR TO THE BID OPENING DATE.</p> <p>(3) ALL ADDENDA SHOULD BE FORMALLY ACKNOWLEDGED BY ALL BIDDERS AND SUBMITTED TO THE STATE PURCHASING DIVISION. THE SAME RULES AND REGULATIONS THAT APPLY TO THE ORIGINAL BIDDING DOCUMENT SHALL ALSO APPLY TO AN ADDENDUM DOCUMENT. THE ONLY EXCEPTION MAY BE FOR AN ADDENDUM THAT IS ISSUED FOR THE SOLE PURPOSE OF CHANGING A BID OPENING TIME AND/OR DATE.</p> <p>REV. 11/96</p> <p>EXHIBIT 10</p> <p>ADDENDUM ACKNOWLEDGEMENT</p> <p>I HEREBY ACKNOWLEDGE RECEIPT OF THE FOLLOWING CHECKED ADDENDUM(S) AND HAVE MADE THE NECESSARY REVISIONS TO MY PROPOSAL, PLANS AND/OR SPECIFICATION, ETC.</p> <p>ADDENDUM NOS.:</p> <p>NO. 1 <i>YES</i>... <i>3-11-07</i></p> <p>NO. 2 <i>YES</i>... <i>3-13-07</i></p> | | | | | | |

SEE REVERSE SIDE FOR TERMS AND CONDITIONS

| | | |
|-----------|-----------|-----------------------------------|
| SIGNATURE | TELEPHONE | DATE |
| TITLE | FEIN | ADDRESS CHANGES TO BE NOTED ABOVE |

WHEN RESPONDING TO RFQ, INSERT NAME AND ADDRESS IN SPACE ABOVE LABELED 'VENDOR'



State of West Virginia
 Department of Administration
 Purchasing Division
 2019 Washington Street East
 Post Office Box 50130
 Charleston, WV 25305-0130

Request for Quotation

RFQ NUMBER
COR61340

PAGE
6

ADDRESS CORRESPONDENCE TO ATTENTION OF
JOHN ABBOTT
304-558-2544

RFQ COPY
 TYPE NAME/ADDRESS HERE

VENDOR

SHIP TO

DIVISION OF CORRECTIONS
617 LEON SULLIVAN WAY
CHARLESTON, WV
25301 **304-558-8045**

| | | | | |
|---|---------------|----------|--------|---------------|
| DATE PRINTED 02/22/2007 | TERMS OF SALE | SHIP VIA | F.O.B. | FREIGHT TERMS |
| BID OPENING DATE: 03/21/2007 BID OPENING TIME 01:30PM | | | | |

| LINE | QUANTITY | UOP | CAT. NO. | ITEM NUMBER | UNIT PRICE | AMOUNT |
|---|----------|-------|----------|-------------|------------|--------|
| NO. 3 | | | | | | |
| NO. 4 | | | | | | |
| NO. 5 | | | | | | |
| <p>I UNDERSTAND THAT FAILURE TO CONFIRM THE RECEIPT OF THE ADDENDUM(S) MAY BE CAUSE FOR REJECTION OF THE BIDS.</p> <p><i>Ronald J. Ki</i>.....SIGNATURE ELCO MECHANICAL CONTRACTORS COMPANY 03/21/2007.....DATE</p> <p>REV. 11/96</p> <p>CONTRACTORS LICENSE</p> <p>WEST VIRGINIA STATE CODE 21-11-2 REQUIRES THAT ALL PERSONS DESIRING TO PERFORM CONTRACTING WORK IN THIS STATE MUST BE LICENSED. THE WEST VIRGINIA CONTRACTORS LICENSING BOARD IS EMPOWERED TO ISSUE THE CONTRACTORS LICENSE. APPLICATIONS FOR A CONTRACTORS LICENSE MAY BE MADE BY CONTACTING THE WEST VIRGINIA DIVISION OF LABOR CAPITOL COMPLEX, BUILDING 3, ROOM 319, CHARLESTON, WV 25305. TELEPHONE: (304) 558-7890.</p> <p>WEST VIRGINIA STATE CODE 21-11-11 REQUIRES ANY PROSPECTIVE BIDDER TO INCLUDE THE CONTRACTORS LICENSE NUMBER ON THEIR BID.</p> <p>BIDDER TO COMPLETE:</p> | | | | | | |

SEE REVERSE SIDE FOR TERMS AND CONDITIONS

| | | |
|-----------|-----------|-----------------------------------|
| SIGNATURE | TELEPHONE | DATE |
| TITLE | FEIN | ADDRESS CHANGES TO BE NOTED ABOVE |

WHEN RESPONDING TO RFQ, INSERT NAME AND ADDRESS IN SPACE ABOVE LABELED 'VENDOR'



State of West Virginia
 Department of Administration
 Purchasing Division
 2019 Washington Street East
 Post Office Box 50130
 Charleston, WV 25305-0130

Request for Quotation

RFQ NUMBER
COR61340

PAGE
7

ADDRESS CORRESPONDENCE TO ATTENTION OF
**JOHN ABBOTT
 304-558-2544**

RFQ COPY
 TYPE NAME/ADDRESS HERE

VENDOR

SHIP TO

**DIVISION OF CORRECTIONS
 617 LEON SULLIVAN WAY
 CHARLESTON, WV
 25301 304-558-8045**

| DATE PRINTED | TERMS OF SALE | SHIP VIA | F.O.B. | FREIGHT TERMS |
|--------------|---------------|----------|--------|---------------|
| 02/22/2007 | | | | |

BID OPENING DATE: **03/21/2007** BID OPENING TIME **01:30PM**

| LINE | QUANTITY | UOP | CAT NO | ITEM NUMBER | UNIT PRICE | AMOUNT |
|---|----------|-----|--------|-------------|------------|--------|
| <p>CONTRACTORS NAME: F.L.C.O. MECHANICAL CONTRACTORS</p> <p>CONTRACTORS LICENSE NO.: W.V. 0020807</p> <p>THE SUCCESSFUL BIDDER WILL BE REQUIRED TO FURNISH A COPY OF THEIR CONTRACTORS LICENSE PRIOR TO ISSUANCE OF A PURCHASE ORDER/CONTRACT</p> <p>APPLICABLE LAW</p> <p>THE WEST VIRGINIA STATE CODE, PURCHASING DIVISION RULE AND REGULATIONS, AND THE INFORMATION PROVIDED IN THE "REQUEST FOR QUOTATION" ISSUED BY THE PURCHASING DIVISION IS THE SOLE AUTHORITY GOVERNING THIS PROCUREMENT.</p> <p>ANY INFORMATION PROVIDED IN SPECIFICATION MANUALS, OR ANY OTHER SOURCE, VERBAL OR WRITTEN, WHICH CONTRADICTS OR ALTERS THE INFORMATION PROVIDED FROM THE SOURCES AS DESCRIBED IN THE ABOVE PARAGRAPH IS VOID AND OF NO EFFECT.</p> <p>BANKRUPTCY: IN THE EVENT THE VENDOR/CONTRACTOR FILES FOR BANKRUPTCY PROTECTION, THIS CONTRACT IS AUTOMATICALLY NULL AND VOID, AND IS TERMINATED WITHOUT FURTHER ORDER.</p> <p>REV. 1/2005</p> <p>NOTICE</p> <p>A SIGNED BID MUST BE SUBMITTED TO:</p> <p>DEPARTMENT OF ADMINISTRATION</p> | | | | | | |

SEE REVERSE SIDE FOR TERMS AND CONDITIONS

| | | |
|-----------|-----------|------|
| SIGNATURE | TELEPHONE | DATE |
|-----------|-----------|------|

| | | |
|-------|------|-----------------------------------|
| TITLE | FEIN | ADDRESS CHANGES TO BE NOTED ABOVE |
|-------|------|-----------------------------------|

WHEN RESPONDING TO RFQ, INSERT NAME AND ADDRESS IN SPACE ABOVE LABELED 'VENDOR'



State of West Virginia
 Department of Administration
 Purchasing Division
 2019 Washington Street East
 Post Office Box 50130
 Charleston, WV 25305-0130

Request for Quotation

RFQ NUMBER
COR61340

PAGE
8

ADDRESS CORRESPONDENCE TO ATTENTION OF
**JOHN ABBOTT
 304-558-2544**

VENDOR

RFQ COPY
 TYPE NAME/ADDRESS HERE

SHIP TO

DIVISION OF CORRECTIONS
 617 LEON SULLIVAN WAY
 CHARLESTON, WV 25301
 304-558-8045

| DATE PRINTED | TERMS OF SALE | SHIP VIA | F.O.B. | FREIGHT TERMS |
|--------------|---------------|----------|--------|---------------|
| 02/22/2007 | | | | |

BID OPENING DATE: **03/21/2007** BID OPENING TIME **01:30PM**

| LINE | QUANTITY | UOP | CAT NO. | ITEM NUMBER | UNIT PRICE | AMOUNT |
|--|----------|-----|---------|-------------|------------|--------|
| | | | | | | |
| <p>PURCHASING DIVISION BUILDING 15 2019 WASHINGTON STREET, EAST CHARLESTON, WV 25305-0130</p> <p>THE BID SHOULD CONTAIN THIS INFORMATION ON THE FACE OF THE ENVELOPE OR THE BID MAY NOT BE CONSIDERED: SEALED BID BUYER: JOHN ABBOTT----- REQ. NO.: COR61340----- BID OPENING DATE: 3/21/2007----- BID OPENING TIME: 01:30 PM-----</p> <p>PLEASE PROVIDE A FAX NUMBER IN CASE IT IS NECESSARY TO CONTACT YOU REGARDING YOUR BID: ----- 304 346 0548 -----</p> <p>PLEASE PRINT OR TYPE NAME OF PERSON TO CONTACT CONCERNING THIS QUOTE: ----- William E. Ashworth -----</p> | | | | | | |

SEE REVERSE SIDE FOR TERMS AND CONDITIONS

| | | |
|-----------|-----------|------|
| SIGNATURE | TELEPHONE | DATE |
|-----------|-----------|------|

| | | |
|-------|------|-----------------------------------|
| TITLE | FEIN | ADDRESS CHANGES TO BE NOTED ABOVE |
|-------|------|-----------------------------------|

WHEN RESPONDING TO RFQ, INSERT NAME AND ADDRESS IN SPACE ABOVE LABELED 'VENDOR'



State of West Virginia
 Department of Administration
 Purchasing Division
 2019 Washington Street East
 Post Office Box 50130
 Charleston, WV 25305-0130

Request for Quotation

RFQ NUMBER
COR61340

PAGE
9

ADDRESS CORRESPONDENCE TO ATTENTION OF
**JOHN ABBOTT
 304-558-2544**

VENDOR

RFQ COPY
 TYPE NAME/ADDRESS HERE

SHIP TO

DIVISION OF CORRECTIONS
 617 LEON SULLIVAN WAY
 CHARLESTON, WV
 25301 304-558-8045

| DATE PRINTED | TERMS OF SALE | SHIP VIA | F.O.B. | FREIGHT TERMS |
|--------------|---------------|----------|--------|---------------|
| 02/22/2007 | | | | |

BID OPENING DATE: **03/21/2007** BID OPENING TIME **01:30PM**

| LINE | QUANTITY | UOP | CAT NO. | ITEM NUMBER | UNIT PRICE | AMOUNT |
|--|----------|-----|---------|-------------|------------|---------------------|
| ***** THIS IS THE END OF RFQ COR61340 ***** TOTAL: | | | | | | <u>\$259,000.00</u> |

SEE REVERSE SIDE FOR TERMS AND CONDITIONS.

| | | |
|------------------------------------|---------------------------|-----------------------------------|
| SIGNATURE <i>Ronald J. K...</i> | TELEPHONE 304-346-0546 | DATE 03/21/2007 |
| TITLE VICE PRESIDENT | FEIN 55-053-4807 | ADDRESS CHANGES TO BE NOTED ABOVE |

WHEN RESPONDING TO RFQ, INSERT NAME AND ADDRESS IN SPACE ABOVE LABELED 'VENDOR'

WV-36A (Rev. 01/01/07)

STATE OF WEST VIRGINIA
PURCHASE CONTINUATION SHEET

Vendor: _____

| | | |
|--|-------|--------------------------------------|
| Buyer: 32 | Page: | Requisition or P.O. No.: COR61340 |
| Spending Unit: Mt Olive Corr Center | | |

Replace all eleven (11) existing York roof top package units with like York units. M/N : DM300N32P2BEB1 OR EQUAL

These units will be supplied with the following factory installed items:

Single enthalpy economizer
 Unit mounted disconnect switch
 High static drive
 Phase Monitor
 Air proving switch
 Hinged filter door & tool-less access
 UNT Controller
 Dirty filter switch

Re-use Disc (As per spec 1)

These units will also be installed with the following field installed items:

Economizer rain hood
 Barometric relief damper 1RD0406

Recovery and disposal of refrigerant per EPA regulations

Units to have DDC control and access through a web based controller, described in Part 2. Basics to include:

Alarming of points to email, pager or text message to a cell phone
 Remote access of trouble shooting and off site assistance to maintenance department
 Set point adjustment from workstation
 All temperatures and control points also available at workstation
 Available expansion for other control of building AHU's, boilers, chillers and additional sensors
 Web based access via Internet Explorer 6 or higher

The web-based controller will also be accessible from a remote location for emergency and PM services.

Factory Operation and Service manuals, and Parts manual will be provided.

One day customer training on the operation of the new HVAC system will be provided.

As built drawings will be provided upon completion of project.

The existing type of control on the RTU's will be replaced with a Metasys Web Based Internet System.

A new laptop workstation is to be supplied by the Contractor for use in the mechanical room by Mt Olive maintenance personnel. Workstation requirements listed in Part 2 Section 1.2.

Detailed specifications follow .

B. General

1. The FMS shall consist of a number of Nodes and associated equipment connected by industry standard network practices. All communication between Nodes shall be by digital means only.
2. The FMS network shall at minimum comprise of the following:
 - a. Operator PCs – fixed or portable
 - b. Network processing, data storage and communication equipment including file servers
 - c. Routers, bridges, switches, hubs, modems and like communications equipment.
 - d. Active processing Nodes including field panels.
 - e. Intelligent and addressable elements and end devices.
 - f. Third-party equipment interfaces.
 - g. Other components required for a complete and working FMS.
3. All FMS features shall be accessible via Enterprise Intranet and Internet browser with equivalent FMS access control for user access.
4. The FMS shall support auto-dial/auto-answer communications to allow FMS Nodes to communicate with other remote FMS Nodes via standard telephone lines. Refer to drawings for type of line to be used, DSL or voice grade. Where no preference is indicated, DSL is the preferred grade.
5. The PC Workstations, File servers and principal network equipment shall be standard products of recognized major manufacturers available through normal PC vendor channels. "Clones" are not acceptable.
6. Provide licenses for all software residing in the FMS system and transfer these licenses to the Owner prior to completion.

C. Network

1. The FMS shall incorporate a primary Tier 1 network. At the Contractor's option, the FMS may also incorporate integrated secondary Tier 2 and tertiary Tier 3 networks.
2. The FMS Network shall utilize an open architecture capable of all of the following:
 - a. Utilizing standard Ethernet communications and operate at a minimum speed of 10/100 Mb/sec
 - b. Connecting via BACnet at the Tier 1 level in accordance with as per ANSI/ASHRAE Standard 135-2001
 - c. Connecting via the N2 Protocol at the Tier 2 level
 - d. Connecting via LonMark as per ANSI/EIA 709 (LonWorks) to LonMark FTT-10 transceivers at the Tier 2 level
3. The FMS network shall support both copper and optical fiber communication media.

D. Third-Party Interfaces

1. FMS Contractor shall integrate, if required for future use, real-time data from systems supplied by other trades.
2. The FMS system shall include necessary FMS hardware equipment and software to allow data communications between the FMS system and systems supplied by other trades.

E. Power Fail / Auto Restart

1. Provide for the automatic orderly and predefined shutdown of parts or all of the FMS following total loss of power to parts or all of the FMS.

- G. Fixed or portable operator PCs shall not require any special software to be purchased from the FMS manufacturer. All actions required for the complete operator interface as described herein shall be accomplished through a common browser.

1.3 Operator Interface

A. General

1. The FMS Operator Interface shall be user friendly, readily understood and shall make maximum use of colors, graphics, icons, embedded images, animation, text based information and data visualization techniques to enhance and simplify the use and understanding of the FMS by authorized users at the OWS.
2. It shall be possible to designate any PC on the Tier 1 network as an Operator Interface point. No special software will need to be purchased from the FMS manufacturer for any such PC.
3. User access to the FMS shall be protected by a flexible and Owner redefinable software-based password access protection. Password protection shall be multi-level and partitionable to accommodate the varied access requirements of the different user groups. Provide the means to define unique access privileges for each individual authorized user. Also provide the means to establish general password groups to which an individual will then be assigned. Once assigned to the group each individual will assume all the capabilities and restrictions of that group. Provide the means to on-line manage password access control under the control of a Master Password.
4. The user interface shall be able to combine data from any and all of the system components in a single browser window. This shall include historical data stored on a server.
5. The Operator Interface shall incorporate comprehensive support for functions including, but not necessarily limited to, the following:
 - a. User access for selective information retrieval and control command execution
 - b. Monitoring and reporting
 - c. Alarm, non-normal, and return to normal condition annunciation
 - d. Selective operator override and other control actions
 - e. Information archiving, manipulation, formatting, display and reporting
 - f. FMS internal performance supervision and diagnostics
 - g. On-line access to user HELP menus
 - h. On-line access to current FMS as-built records and documentation
 - i. Means for the controlled re-programming, re-configuration of FMS operation and for the manipulation of FMS database information in compliance with the prevailing codes, approvals and regulations for individual FMS applications
6. Provide FMS reports and displays making maximized use of simple English language descriptions and readily understood acronyms, abbreviations and the like to assist user understanding and interpretation. All text naming conventions shall be consistent in their use and application throughout the FMS.

E. Reports

1. Reports shall be generated and directed to one or more of the following: User interface displays, printers, or archive at the user's option. As a minimum, the system shall provide the following reports:
 - a. All points in the FMS.
 - b. All points in each FMS application.
 - c. All points in a specific AN.
 - d. All points in a user-defined group of points.
 - e. All points currently in alarm in an FMS application.
 - f. All points locked out in an FMS application.
 - g. All FMS schedules
 - h. All user defined and adjustable variables, schedules, interlocks and the like.
 - i. FMS diagnostic and system status reports
2. Provide all applicable standard reports of the FMS manufacturer.
3. Provide for the generation by the user of custom reports as specified in Part 3.

F. Dynamic Color Graphics

1. An unlimited number of graphic displays shall be able to be generated and executed.
2. Graphics shall be based on Scalar Vector Graphic (SVG) technology.
3. Values of real time attributes displayed on the graphics shall be dynamic and updated on the displays.
4. The graphic displays shall be able to display and provide animation based on real-time FMS data that is acquired, derived, or entered.
5. The user shall be able to change values (setpoints) and states in system controlled equipment directly from the graphic display.
6. Provide a graphic editing tool that allows for the creation and editing of graphic files. It shall be possible to edit the graphics directly while they are on line, or at an off line location for later downloading to the AN.
7. FMS system shall be provided with a complete user expandable symbol library containing all of the basic symbols used to represent components of a typical FMS system. Implementing these symbols in a graphic shall involve dragging and dropping them from the library to the graphic.

G. Schedules

1. The system shall provide multiple schedule input forms for automatic FMS time-of-day scheduling and override scheduling of FMS operations. At a minimum, the following spreadsheet types shall be accommodated:
 - a. Weekly schedules
 - b. Temporary override schedules.
 - c. Special "Only Active If Today Is A Holiday" schedules.
 - d. Monthly schedules
2. Schedules shall be provided for each system or sub-system in the FMS. Each schedule shall include all commandable points residing within the system. Each point may have a unique schedule of operation relative to the system use schedule, allowing for sequential starting and control of equipment within the system. Scheduling and rescheduling of points shall be accomplished easily via the system schedule spreadsheets.

7. The AN shall be capable of direct connection to multiple field busses using different protocols simultaneously as indicated below. Should the controller not support multiple field busses, install two primary nodes side by side.
 - a. An RS-485 serial field bus such as MSTP or the manufacturer's proprietary field bus.
 - b. A LON field bus for supervision and control of LON based controllers that conform to the Lon Talk standard.
8. The primary nodes will integrate data from both field busses into a common object structure. Data from both field busses will appear in common displays throughout the user interface in exactly the same format. It shall not be possible to determine which field buss the data originated on without reviewing the system configuration data.
9. AN shall be programmable and governed by the requirements of their applicable codes, approvals and regulations.
10. The AN shall be designed, packaged, installed, programmed and commissioned in consideration of their specific service and prevailing operating conditions. They shall be proven standard product of their original manufacturer and not a custom product for this Project.
11. A failure at an AN shall not cause failures or non-normal operation at any other system AN other than the possible loss of active real-time information from the failed AN.
12. Ancillary AN equipment, including interfaces and power supplies, shall not be operated at more than 80% of their rated service capacity.
13. AN shall comply with FCC Part 15 subpart J class A emission requirements.
14. Each primary node shall be equipped with the necessary un-interruptible power such that it will not cease operation during minor power outages, including those that occur upon transfer to emergency generator or other local power source not provided by the utility.

B. HVAC Node

1. HVAC Node shall provide both standalone and networked direct digital control of HVAC systems.
2. A dedicated HVAC Node shall be configured and provided for each primary HVAC system (air handler, chiller, boiler) and each terminal HVAC system (VAV Box, Unit Heater, Fan Coil Unit, Cabinet Heater, Heat Pump, Fan Powered Box, CV Box)
3. Each HVAC Node shall retain program, control algorithms, and setpoint information in non-volatile memory in the event of a power failure, and shall return to normal operation upon restoration of power.
4. Each HVAC Node shall report its communication status to the FMS. The FMS shall provide a system advisory upon communication failure and restoration.
5. For each primary HVAC system, provide means of indication of system performance and setpoints at, or adjacent to the HVAC Node.
6. For each primary HVAC system, provide a means to adjust setpoints and start/stop equipment at, or adjacent to the HVAC Node.
7. Provide a means to prevent unauthorized personnel from accessing setpoint adjustments and equipment control functions.

An emergency response will be in the process control that would consist of two responses activated by a software command.

Response includes:

1. External Threat: All fans (under DDC control) will be shut off and all dampers will be closed to minimize any air infiltration into the building.
2. Internal Threat: All fans (under DDC control) to be commanded on and all dampers commanded to the 100% open position, overriding any safeties possible, to exhaust as much air as possible from the building and introduce fresh air.
 - The threat response is only for DDC controlled components of the HVAC system and sealing of the dampers can only be as good as the existing equipment can provide.

Project Name Mt. Olive Correctional Facility
 Architect
 Engineer
 Purchaser
 Submitted By

QUANTITY: 11 UNITS DESIGNATION: Schedule No:

Model No: DM300N32P2BEB1

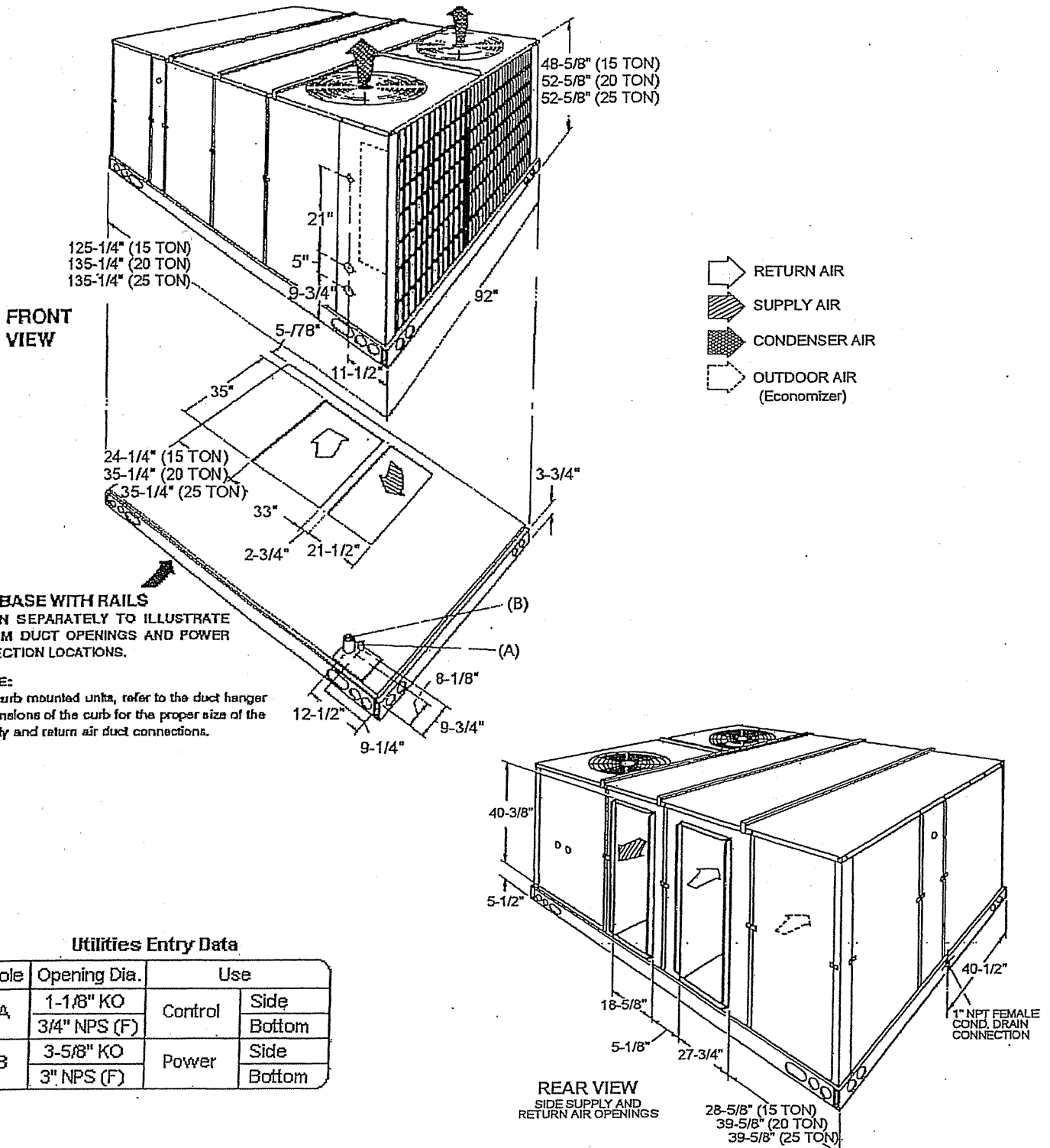

Utilities Entry Data

| Hole | Opening Dia. | Use | |
|------|--------------|---------|--------|
| A | 1-1/8" KO | Control | Side |
| | 3/4" NPS (F) | | Bottom |
| B | 3-5/8" KO | Power | Side |
| | 3" NPS (F) | | Bottom |

GUIDE SPECIFICATIONS

GENERAL

Units shall be manufactured by York International Unitary Products Group in an ISO 9001 certified facility.

York's Sunline 2000™ units are convertible single package units. All models have dual independent refrigerant circuits for efficient part load operation and maximum comfort control. Although the units are primarily designed for curb mounting on a roof, they can also be slab-mounted at ground level or set on steel beams above a finished roof. Cooling only, cooling with gas heat and cooling with electric heat models are available with a wide variety of factory-mounted options and field-installed accessories to make them suitable for almost every application. All units are self-contained and assembled on full perimeter base rails with holes in the four corners for overhead rigging. Every unit is completely piped, wired, charged and tested at the factory to simplify the field installation and to provide years of dependable operation. All models (including those with an economizer) are suitable for either bottom or horizontal duct connections. Models with power exhaust are suitable for bottom duct connections only. For bottom duct, remove the sheet metal panels from the supply and return air openings through the base of the unit. For horizontal duct, replace the supply and return air panels on the rear of the unit with a side duct flange accessory. All supply air blowers are equipped with a belt drive that can be adjusted to meet the exact requirements of the job.

Each unit shall have 2 condenser fan motors. A high speed drive accessory is available for applications with a higher CFM and/or static pressure requirement. All compressors include crankcase heat and internal pressure relief. Every refrigerant circuit includes an expansion valve, a liquid line filter-drier, a discharge line high pressure switch and a suction line with a freestat and low pressure/loss of charge switch. The unit control circuit includes a 75 VA transformer, a 24-volt circuit breaker and a relay board with two compressor lockout circuits, a terminal strip for thermostat wiring, plus an additional set of pin connectors to simplify the interface of additional field controls. All units have long lasting powder paint cabinets with 1000 hour salt spray test approval under ASTM-B117 procedures. All models are CSA approved. All models include a 1-year limited warranty on the complete unit. Compressors and electric heater elements carry an additional 4-year warranty. Aluminized steel tubular heat exchangers carry an additional 9-year warranty.

DESCRIPTION

Units shall be factory-assembled, single packaged, DM***N Electric Cooling/Gas Heat, DM***C/E Electric Cooling/Optional Electric Heat, designed for outdoor mounted installation. The 15, 20 and 25 ton units shall have minimum EER ratings of 8.5.

They shall have built-in field convertible duct connections for down discharge supply/return or horizontal discharge supply/return, and be available with factory installed options or field installed accessories. The units shall be factory wired, piped, charged with R-22 refrigerant and factory tested prior to ship-

ment. All unit wiring shall be both numbered and color coded. All units shall be manufactured in a facility certified to ISO 9001 standards and the cooling performance shall be rated in accordance with DOE and ARI test procedures. Units shall be CGA listed, classified to ANSI Z21.47 standards, UL 1995/CAN/CSA No. 236-M90 conditions.

UNIT CABINET

Unit cabinet shall be constructed of G90 galvanized steel, with exterior surfaces coated with a non-chalking, powdered paint finish, certified at 1000 hours salt spray test per ASTM-B117 standards. Indoor blower section shall be insulated with a minimum 1/2" thick insulation, coated on the airside. Aluminum foil faced insulation shall be used in the furnace compartment and be fastened with ridged fasteners to prevent insulation from entering the air stream. Cabinet panels shall be "large" size, easily removable for servicing and maintenance. Full perimeter base rails shall be provided to assure reliable transit of equipment, overhead rigging and proper sealing on roof curb applications. Disposable 2" filters shall be furnished and be accessible through a removable access door, sealed airtight. Units filter track shall be designed to accommodate either 2" or 4" filters. Fan performance measuring ports shall be provided on the outside of the cabinet to allow accurate air measurements of evaporator fan performance without removing panels or creating air by-pass of the coils. Condensate pan shall be internally sloped and conform to ASHRAE 62-89 self-draining standards. Condensate connection shall be a minimum of 1" I.D. female and be a ridged mount connection. Unit shall incorporate a fixed outdoor air damper with an outdoor air intake opening covered with a bird screen and a rain hood painted to match the exterior of the unit.

INDOOR (EVAPORATOR) FAN ASSEMBLY

Fan shall be a belt drive assembly and include an adjustable-pitch motor pulley. Job site selected (B.H.P.) brake horsepower shall not exceed the motors nameplate horsepower rating, plus the service factor. Units shall be designed not to operate above service factor. Fan wheel shall be double-inlet type with forward-curved blades, dynamically balanced to operate smoothly throughout the entire range of operation. Airflow design shall be constant air volume.

OUTDOOR (CONDENSER) FAN ASSEMBLY

The outdoor fans shall be of the direct-driven propeller type, discharge air vertically, have aluminum blades riveted to corrosion resistant steel spider brackets and shall be dynamically balanced for smooth operation. The 2 outdoor fan motors shall be totally enclosed with permanently lubricated bearings, internally protected against overload conditions and staged independently.

REFRIGERANT COMPONENTS

Compressors:

- a. Shall be Scroll (25T only) compressors internally protected with internal high-pressure relief and over temperature protection.

~~Electric Heat Element 5 Years~~

- Other Parts 1 Year

OPTIONAL OUTDOOR AIR (Shall be made available by either/or):

- **ELECTRONIC ENTHALPY AUTOMATIC ECONOMIZER** - Outdoor and return air dampers that are interlocked and positioned by a fully-modulating, spring-return damper actuator. The maximum leakage rate for the outdoor air intake dampers shall not exceed 2% when dampers are fully closed and operating against a pressure differential of 0.5 IWG. A unit-mounted potentiometer shall be provided to adjust the outdoor and return air damper assembly to take in CFM of outdoor air to meet the minimum ventilation requirement of the conditioned space during normal operation. During economizer operation, a mixed-air temperature control shall modulate the outdoor and return air damper assembly to prevent the supply air temperature from dropping below 55°F. Changeover from compressor to economizer operation shall be provided by an integral electronic enthalpy control that feeds input into the basic module. The outdoor intake opening shall be covered with a rain hood that matches the exterior of the unit. Water eliminator/filters shall be provided. Simultaneous economizer/compressor operation is also possible. Dampers shall fully close on power loss.

- ~~• **MOTORIZED OUTDOOR AIR DAMPERS** - Outdoor and return air dampers that are interlocked and positioned by a 2-position, spring-return damper actuator. The maximum leakage rate for the outdoor air intake dampers shall not exceed 2% when dampers are fully closed and operating against a pressure differential of 0.5 IWG. A unit-mounted potentiometer shall be provided to adjust the outdoor and return air damper assembly to take in the design CFM of outdoor air to meet the ventilation requirements of the conditioned space during normal operation. Whenever the indoor fan motor is energized, the dampers open up to one of two pre-selected positions - regardless of the outdoor air enthalpy. Dampers return to the fully closed position when the indoor fan motor is de-energized. Dampers shall fully close on power loss.~~

OTHER PRE-ENGINEERED ACCESSORIES AVAILABLE

- **ROOF CURB** - 14" high, full perimeter curb with wood nailer (shipped knocked-down).
- **100% BAROMETRIC RELIEF DAMPER** - Contains a rain hood, air inlet screen, exhaust damper and mounting hardware. Used to relieve internal air pressure through the unit.
- **PROPANE CONVERSION KIT** - Contains new orifices and gas valve parts to convert from natural to L.P. gas. One per unit required.

- **HIGH ALTITUDE - NATURAL GAS** - Contains orifices required for applications between 2000 and 6000 feet altitude.
- **HIGH ALTITUDE - PROPANE GAS** - Contains orifices required for applications between 2000 and 6000 feet altitude. Must be used with propane conversion kit.
- **BURGLAR BARS** - Designed to work with above roof curbs, depending on unit model. Fits duct openings of curb supply and return air openings.
- **SIDE DUCT FLANGE** - Supply and return air duct flanges for side duct applications. Do not use on units with power exhaust.
- **HIGH SPEED DRIVE** - Includes blower pulley and belt for higher CFM and/or static pressure requirements.
- **WOOD SKID** - Allows unit to be handled with 90" forks.
- **ECONOMIZER/MOTORIZED DAMPER RAIN HOOD (DMN/E/C300 only)** - Contains all hood panels and the hardware for assembling.
- **ANTI-RECYCLE TIMER** - Assures 5-minute off time between compressor cycles.
- **COIL GUARD KIT** - Guard for cooling coil.

OTHER FACTORY INSTALLED OPTIONS

- **POWER EXHAUST OPTION** - To work in conjunction with economizers.
- **STAINLESS STEEL HEAT EXCHANGER**
- **STAINLESS STEEL DRAIN PAN**
- **TECHNICOAT PHENOLIC COATED CONDENSER AND EVAPORATOR COIL**
- **ELECTRONIC SINGLE ENTHALPY ECONOMIZER**
- **DIRTY FILTER SWITCH**
- **PHASE MONITOR**
- **COIL GUARD**
- **POWERED GFI CONVENIENCE OUTLET**
- **NON-POWERED GFI CONVENIENCE OUTLET**
- **BAS CONTROLS (Simplicity® INTELLI-Comfort™ CPC, JOHNSON, HONEYWELL, NOVAR)**
- **BAS READY ECONOMIZER (BELIMO ACTUATOR WITHOUT A CONTROLLER)**
- **HINGED FILTER DOOR ACCESS AND TOOLLESS ACCESS PANELS**
- **HIGH SPEED DRIVE**
- **2" THROW AWAY FILTERS**
- **4" PLEATED FILTERS**
- **DISCONNECT SWITCH**
- **SUPPLY AIR SMOKE DETECTOR**
- **RETURN AIR SMOKE DETECTOR**

AFFIDAVIT

West Virginia Code §5A-3-10a states:

No contract or renewal of any contract may be awarded by the state or any of its political subdivisions to any vendor or prospective vendor when the vendor or prospective vendor or a related party to the vendor or prospective vendor is a debtor and the debt owned is an amount greater than one thousand dollars in the aggregate

DEFINITIONS:

"Debt" means any assessment, premium, penalty, fine, tax or other amount of money owed to the state or any of its political subdivisions because of a judgment, fine, permit violation, license assessment, defaulted workers' compensation premium, penalty or other assessment presently delinquent or due and required to be paid to the state or any of its political subdivisions, including any interest or additional penalties accrued thereon.

"Debtor" means any individual, corporation, partnership, association, limited liability company or any other form or business association owing a debt to the state or any of its political subdivisions. "Political subdivision" means any county commission; municipality; county board of education; any instrumentality established by a county or municipality; any separate corporation or instrumentality established by one or more counties or municipalities, as permitted by law; or any public body charged by law with the performance of a government function or whose jurisdiction is coextensive with one or more counties or municipalities. "Related party" means a party, whether an individual, corporation, partnership, association, limited liability company or any other form or business association or other entity whatsoever, related to any vendor by blood, marriage, ownership or contract through which the party has a relationship of ownership or other interest with the vendor so that the party will actually or by effect receive or control a portion of the benefit, profit or other consideration from performance of a vendor contract with the party receiving an amount that meets or exceed five percent of the total contract amount.

EXCEPTION:

The prohibition of this section does not apply where a vendor has contested any tax administered pursuant to chapter eleven of this code, workers' compensation premium, permit fee or environmental fee or assessment and the matter has not become final or where the vendor has entered into a payment plan or agreement and the vendor is not in default of any of the provisions of such plan or agreement.

LICENSING:

Vendors must be licensed and in good standing in accordance with any and all state and local laws and requirements by any state or local agency of West Virginia, including, but not limited to, the West Virginia Secretary of State's Office, the West Virginia Tax Department, West Virginia Insurance Commission, or any other state agencies or political subdivision. Furthermore, the vendor must provide all necessary releases to obtain information to enable the Director or spending unit to verify that the vendor is licensed and in good standing with the above entities.

CONFIDENTIALITY:

The vendor agrees that he or she will not disclose to anyone, directly or indirectly, any such personally identifiable information or other confidential information gained from the agency, unless the individual who is the subject of the information consents to the disclosure in writing or the disclosure is made pursuant to the agency's policies, procedures and rules. Vendors should visit www.state.wv.us/admin/purchase/privacy for the Notice of Agency Confidentiality Policies.

Under penalty of law for false swearing (West Virginia Code, §61-5-3), it is hereby certified that the vendor acknowledges the information in this said affidavit and are in compliance with the requirements as stated.

Vendor's Name: Elec MECHANICAL CONTRACTORS

Authorized Signature:  Date: 03/21/2007

BID BOND

KNOW ALL MEN BY THESE PRESENTS, That we, the undersigned, Elco Mechanical Contractors, Inc.
_____ of Charleston, WV, as Principal, and Fidelity and Deposit Company of
Maryland of Pittsburgh, PA, a corporation organized and existing under the laws of the State of _____
MD with its principal office in the City of Pittsburgh, as Surety, are held and firmly bound unto the State
of West Virginia, as Obligee, in the penal sum of Five Percent of Amount Bid (\$ _____ 5% _____) for the payment of which,
well and truly to be made, we jointly and severally bind ourselves, our heirs, administrators, executors, successors and assigns.

The Condition of the above obligation is such that whereas the Principal has submitted to the Purchasing Section of the
Department of Administration a certain bid or proposal, attached hereto and made a part hereof, to enter into a contract in writing for
COR61340 - Heating/Cooling Unit Installation Mt. Olive Correction Center

NOW THEREFORE,

- (a) If said bid shall be rejected, or
- (b) If said bid shall be accepted and the Principal shall enter into a contract in accordance with the bid or proposal attached
hereto and shall furnish any other bonds and insurance required by the bid or proposal, and shall in all other respects perform the
agreement created by the acceptance of said bid, then this obligation shall be null and void, otherwise this obligation shall remain in full
force and effect. It is expressly understood and agreed that the liability of the Surety for any and all claims hereunder shall, in no event,
exceed the penal amount of this obligation as herein stated.

The Surety, for the value received, hereby stipulates and agrees that the obligations of said Surety and its bond shall be in no
way impaired or affected by any extension of the time within which the Obligee may accept such bid, and said Surety does hereby
waive notice of any such extension.

IN WITNESS WHEREOF, Principal and Surety have hereunto set their hands and seals, and such of them as are corporations
have caused their corporate seals to be affixed hereunto and these presents to be signed by their proper officers, this
21st day of March, 2007.

Principal Corporate Seal

Elco Mechanical Contractors, Inc.

(Name of Principal)

By *[Signature]*

(Must be President or
Vice President)

VICE PRESIDENT
(Title)

Surety Corporate Seal

Fidelity and Deposit Company of Maryland

(Name of Surety)

By: *[Signature]*

Pamela V. Lanham Attorney-in-Fact

IMPORTANT – Surety executing bonds must be licensed in West Virginia to transact surety insurance. Corporate seals must be affixed,
and a power of attorney must be attached.

**Power of Attorney
FIDELITY AND DEPOSIT COMPANY OF MARYLAND**

KNOW ALL MEN BY THESE PRESENTS: That the FIDELITY AND DEPOSIT COMPANY OF MARYLAND, a corporation of the State of Maryland, by FRANK E. MARTIN JR., Vice President, and GREGORY E. MURRAY, Assistant Secretary, in pursuance of authority granted by Article VI, Section 2, of the By-Laws of said Company, which are set forth on the reverse side hereof and are hereby certified to be in full force and effect on the date hereof does hereby nominate, constitute and appoint **Andrew K. TEETER, Janis K. PEACOCK, Kimberly L. MILES, Douglas P. TAYLOR, Donna J. PRICE and Pamela V. LANHAM, all of Charleston, West Virginia, EACH** its true and lawful agent and Attorney-in-Fact, to make, execute, seal and deliver, for, and on its behalf as surety, and as its act and deed: **any and all bonds and undertakings**, and the execution of such bonds or undertakings in pursuance of these presents, shall be as binding upon said Company, as fully and amply, to all intents and purposes, as if they had been duly executed and acknowledged by the regularly elected officers of the Company at its office in Baltimore, Md., in their own proper persons. This power of attorney revokes that issued on behalf of Andrew K. TEETER, Janis K. PEACOCK, Kimberly L. MILES, Douglas P. TAYLOR, Donna J. PRICE, dated July 13, 2004.

The said Assistant Secretary does hereby certify that the extract set forth on the reverse side hereof is a true copy of Article VI, Section 2, of the By-Laws of said Company, and is now in force.

IN WITNESS WHEREOF, the said Vice-President and Assistant Secretary have hereunto subscribed their names and affixed the Corporate Seal of the said FIDELITY AND DEPOSIT COMPANY OF MARYLAND, this 11th day of November, A.D. 2004.

ATTEST:

FIDELITY AND DEPOSIT COMPANY OF MARYLAND

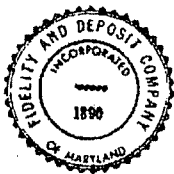

Gregory E. Murray

Frank E. Martin Jr.

By: *Gregory E. Murray* Assistant Secretary *Frank E. Martin Jr.* Vice President

State of Maryland }
City of Baltimore } ss:

On this 11th day of November, A.D. 2004, before the subscriber, a Notary Public of the State of Maryland, duly commissioned and qualified, came FRANK E. MARTIN JR., Vice President, and GREGORY E. MURRAY, Assistant Secretary of the FIDELITY AND DEPOSIT COMPANY OF MARYLAND, to me personally known to be the individuals and officers described in and who executed the preceding instrument, and they each acknowledged the execution of the same, and being by me duly sworn, severally and each for himself deposed and saith, that they are the said officers of the Company aforesaid, and that the seal affixed to the preceding instrument is the Corporate Seal of said Company, and that the said Corporate Seal and their signatures as such officers were duly affixed and subscribed to the said instrument by the authority and direction of the said Corporation.

IN TESTIMONY WHEREOF, I have hereunto set my hand and affixed my Official Seal the day and year first above written.



Maria D. Adamski

Maria D. Adamski Notary Public
My Commission Expires: July 8, 2007