



State of West Virginia
 Department of Administration
 Purchasing Division
 2019 Washington Street East
 Post Office Box 50130
 Charleston, WV 25305-0130

Request for Quotation

RFQ NUMBER
857C2050

PAGE
1

ADDRESS CORRESPONDENCE TO ATTENTION OF:
JOHN JOHNSTON
304-558-2402

VENDOR
 *820131035 814-432-9347
FRANKLIN INDUSTRIES CO
645 ATLANTIC AVENUE
FRANKLIN PA 16323

SHIP TO
DIVISION OF HIGHWAYS
VARIOUS LOCALES AS INDICATED
BY ORDER

DATE PRINTED	TERMS OF SALE	SHIP VIA	F.O.B.	FREIGHT TERMS
03/22/2007				

BID OPENING DATE: **04/18/2007** BID OPENING TIME **01:30PM**

LINE	QUANTITY	UOP	CAT. NO.	ITEM NUMBER	UNIT PRICE	AMOUNT
0001	1	LS		210-16		
GALVANIZED STEEL U-CHANNEL SIGN SUPPORTS OPEN END CONTRACT TO FURNISH GALVANIZED STEEL U-CHANNEL SIGN SUPPORTS AND MISCELLANEOUS HARDWARE TO THE WEST VIRGINIA DIVISION OF HIGHWAYS AS PER THE ATTACHED SPECIFICATIONS EXHIBIT 3 LIFE OF CONTRACT: THIS CONTRACT BECOMES EFFECTIVE ON AND EXTENDS FOR A PERIOD OF ONE (1) YEAR OR UNTIL SUCH "REASONABLE TIME" THEREAFTER AS IS NECESSARY TO OBTAIN A NEW CONTRACT OR RENEW THE ORIGINAL CONTRACT. THE "REASONABLE TIME" PERIOD SHALL NOT EXCEED TWELVE (12) MONTHS. DURING THIS "REASONABLE TIME" THE VENDOR MAY TERMINATE THIS CONTRACT FOR ANY REASON UPON GIVING THE DIRECTOR OF PURCHASING 30 DAYS WRITTEN NOTICE. UNLESS SPECIFIC PROVISIONS ARE STIPULATED ELSEWHERE IN THIS CONTRACT DOCUMENT, THE TERMS, CONDITIONS AND PRICING SET HEREIN ARE FIRM FOR THE LIFE OF THE CONTRACT. RENEWAL: THIS CONTRACT MAY BE RENEWED UPON THE MUTUAL WRITTEN CONSENT OF THE SPENDING UNIT AND VENDOR, SUBMITTED TO THE DIRECTOR OF PURCHASING THIRTY (30) DAYS PRIOR TO THE EXPIRATION DATE. SUCH RENEWAL SHALL BE IN ACCORDANCE WITH THE TERMS AND CONDITIONS OF THE ORIGINAL CONTRACT AND SHALL BE LIMITED TO TWO (2) ONE (1) YEAR PERIODS.						

RECEIVED
 2007 APR 17 A 9 22
 PURCHASING DIVISION
 STATE OF WV

SEE REVERSE SIDE FOR TERMS AND CONDITIONS

SIGNATURE *JW* TELEPHONE **814-437-3726** DATE **4-16-07**

TITLE **V.P. Sales** FEIN **412051057** ADDRESS CHANGES TO BE NOTED ABOVE

WHEN RESPONDING TO RFQ, INSERT NAME AND ADDRESS IN SPACE ABOVE LABELED 'VENDOR'



State of West Virginia
 Department of Administration
 Purchasing Division
 2019 Washington Street East
 Post Office Box 50130
 Charleston, WV 25305-0130

Request for Quotation

RFQ NUMBER
857C2050

PAGE
2

ADDRESS CORRESPONDENCE TO ATTENTION OF:
JOHN JOHNSTON 304-558-2402

VENDOR

*820131035 814-432-9347
 FRANKLIN INDUSTRIES CO
 645 ATLANTIC AVENUE
 FRANKLIN PA 16323

SHIP TO

DIVISION OF HIGHWAYS
 VARIOUS LOCALES AS INDICATED
 BY ORDER

DATE PRINTED	TERMS OF SALE	SHIP VIA	F.O.B	FREIGHT TERMS
03/22/2007				

BID OPENING DATE: 04/18/2007 BID OPENING TIME 01:30PM

LINE	QUANTITY	UOP	CAT NO	ITEM NUMBER	UNIT PRICE	AMOUNT
<p>CANCELLATION: THE DIRECTOR OF PURCHASING RESERVES THE RIGHT TO CANCEL THIS CONTRACT IMMEDIATELY UPON WRITTEN NOTICE TO THE VENDOR IF THE COMMODITIES AND/OR SERVICES SUPPLIED ARE OF AN INFERIOR QUALITY OR DO NOT CONFORM TO THE SPECIFICATIONS OF THE BID AND CONTRACT HEREIN.</p> <p>OPEN MARKET CLAUSE: THE DIRECTOR OF PURCHASING MAY AUTHORIZE A SPENDING UNIT TO PURCHASE ON THE OPEN MARKET, WITHOUT THE FILING OF A REQUISITION OR COST ESTIMATE, ITEMS SPECIFIED ON THIS CONTRACT FOR IMMEDIATE DELIVERY IN EMERGENCIES DUE TO UNFORESEEN CAUSES (INCLUDING BUT NOT LIMITED TO DELAYS IN TRANSPORTATION OR AN UNANTICIPATED INCREASE IN THE VOLUME OF WORK.)</p> <p>QUANTITIES: QUANTITIES LISTED IN THE REQUISITION ARE APPROXIMATIONS ONLY, BASED ON ESTIMATES SUPPLIED BY THE STATE SPENDING UNIT. IT IS UNDERSTOOD AND AGREED THAT THE CONTRACT SHALL COVER THE QUANTITIES ACTUALLY ORDERED FOR DELIVERY DURING THE TERM OF THE CONTRACT, WHETHER MORE OR LESS THAN THE QUANTITIES SHOWN.</p> <p>ORDERING PROCEDURE: SPENDING UNIT(S) SHALL ISSUE A WRITTEN STATE CONTRACT ORDER (FORM NUMBER WV-39) TO THE VENDOR FOR COMMODITIES COVERED BY THIS CONTRACT. THE ORIGINAL COPY OF THE WV-39 SHALL BE MAILED TO THE VENDOR AS AUTHORIZATION FOR SHIPMENT, A SECOND COPY MAILED TO THE PURCHASING DIVISION, AND A THIRD COPY RETAINED BY THE SPENDING UNIT.</p> <p>BANKRUPTCY: IN THE EVENT THE VENDOR/CONTRACTOR FILES FOR BANKRUPTCY PROTECTION, THIS CONTRACT IS AUTOMATICALLY NULL AND VOID, AND IS TERMINATED WITHOUT FURTHER ORDER.</p>						

SEE REVERSE SIDE FOR TERMS AND CONDITIONS

SIGNATURE	TELEPHONE	DATE
-----------	-----------	------

TITLE	FEIN	ADDRESS CHANGES TO BE NOTED ABOVE
-------	------	-----------------------------------

WHEN RESPONDING TO RFQ, INSERT NAME AND ADDRESS IN SPACE ABOVE LABELED 'VENDOR'



State of West Virginia
 Department of Administration
 Purchasing Division
 2019 Washington Street East
 Post Office Box 50130
 Charleston, WV 25305-0130

Request for Quotation

RFQ NUMBER:
857C2050

PAGE
3

ADDRESS CORRESPONDENCE TO ATTENTION OF:
**JOHN JOHNSTON
 304-558-2402**

VENDOR

*820131035 814-432-9347
FRANKLIN INDUSTRIES CO
645 ATLANTIC AVENUE

FRANKLIN PA 16323

SHIP TO

DIVISION OF HIGHWAYS
VARIOUS LOCALES AS INDICATED
BY ORDER

DATE PRINTED	TERMS OF SALE	SHIP VIA	F.O.B	FREIGHT TERMS
03/22/2007				

BID OPENING DATE: **04/18/2007** BID OPENING TIME **01:30PM**

LINE	QUANTITY	UOP	CAT NO.	ITEM NUMBER	UNIT PRICE	AMOUNT
<p>THE TERMS AND CONDITIONS CONTAINED IN THIS CONTRACT SHALL SUPERSEDE ANY AND ALL SUBSEQUENT TERMS AND CONDITIONS WHICH MAY APPEAR ON ANY ATTACHED PRINTED DOCUMENTS SUCH AS PRICE LISTS, ORDER FORMS, SALES AGREEMENTS OR MAINTENANCE AGREEMENTS, INCLUDING ANY ELECTRONIC MEDIUM SUCH AS CD-ROM.</p> <p>REV. 04/11/2001</p> <p>PURCHASING CARD ACCEPTANCE: THE STATE OF WEST VIRGINIA CURRENTLY UTILIZES A VISA PURCHASING CARD PROGRAM WHICH IS ISSUED THROUGH A BANK. THE SUCCESSFUL VENDOR MUST ACCEPT THE STATE OF WEST VIRGINIA VISA PURCHASING CARD FOR PAYMENT OF ALL ORDERS PLACED BY ANY STATE AGENCY FOR ORDERS THAT ARE LESS THAN \$2,500 AS A CONDITION OF AWARD.</p> <p style="text-align: center;">VENDOR PREFERENCE CERTIFICATE</p> <p>CERTIFICATION AND APPLICATION* IS HEREBY MADE FOR PREFERENCE IN ACCORDANCE WITH WEST VIRGINIA CODE, 5A-3-37 (DOES NOT APPLY TO CONSTRUCTION CONTRACTS).</p> <p>A. APPLICATION IS MADE FOR 2.5% PREFERENCE FOR THE REASON CHECKED:</p> <p>() BIDDER IS AN INDIVIDUAL RESIDENT VENDOR AND HAS RESIDED CONTINUOUSLY IN WEST VIRGINIA FOR FOUR (4) YEARS IMMEDIATELY PRECEDING THE DATE OF THIS CERTIFICATION; OR</p> <p>() BIDDER IS A PARTNERSHIP, ASSOCIATION OR CORPORATION RESIDENT VENDOR AND HAS MAINTAINED ITS HEAD-QUARTERS OR PRINCIPAL PLACE OF BUSINESS CONTINUOUSLY IN WEST VIRGINIA FOR FOUR (4) YEARS IMMEDIATELY PRECEDING</p>						

SEE REVERSE SIDE FOR TERMS AND CONDITIONS

SIGNATURE	TELEPHONE	DATE
TITLE	FEIN	ADDRESS CHANGES TO BE NOTED ABOVE

WHEN RESPONDING TO RFQ, INSERT NAME AND ADDRESS IN SPACE ABOVE LABELED 'VENDOR'



State of West Virginia
 Department of Administration
 Purchasing Division
 2019 Washington Street East
 Post Office Box 50130
 Charleston, WV 25305-0130

Request for Quotation

RFQ NUMBER
857C2050

PAGE
4

ADDRESS CORRESPONDENCE TO ATTENTION OF:
JOHN JOHNSTON 304-558-2402

VENDOR

*820131035 814-432-9347
 FRANKLIN INDUSTRIES CO
 645 ATLANTIC AVENUE
 FRANKLIN PA 16323

SHIP TO

DIVISION OF HIGHWAYS
 VARIOUS LOCALES AS INDICATED
 BY ORDER

DATE PRINTED	TERMS OF SALE	SHIP VIA	F.O.B.	FREIGHT TERMS
03/22/2007				

BID OPENING DATE: **04/18/2007** BID OPENING TIME **01:30PM**

LINE	QUANTITY	UOP	CAT. NO.	ITEM NUMBER	UNIT PRICE	AMOUNT
<p>THE DATE OF THIS CERTIFICATION; OR 80% OF THE OWNERSHIP INTEREST OF BIDDER IS HELD BY ANOTHER INDIVIDUAL, PARTNERSHIP, ASSOCIATION OR CORPORATION RESIDENT VENDOR WHO HAS MAINTAINED ITS HEADQUARTERS OR PRINCIPAL PLACE OF BUSINESS CONTINUOUSLY IN WEST VIRGINIA FOR FOUR (4) YEARS IMMEDIATELY PRECEDING THE DATE OF THIS CERTIFICATION; OR</p> <p>() BIDDER IS A CORPORATION NONRESIDENT VENDOR WHICH HAS AN AFFILIATE OR SUBSIDIARY WHICH EMPLOYS A MINIMUM OF ONE HUNDRED STATE RESIDENTS AND WHICH HAS MAINTAINED ITS HEADQUARTERS OR PRINCIPAL PLACE OF BUSINESS WITHIN WEST VIRGINIA CONTINUOUSLY FOR THE FOUR (4) YEARS IMMEDIATELY PRECEDING THE DATE OF THIS CERTIFICATION.</p> <p>B. APPLICATION IS MADE FOR 2.5% PREFERENCE FOR THE REASON CHECKED:</p> <p>() BIDDER IS A RESIDENT VENDOR WHO CERTIFIES THAT, DURING THE LIFE OF THE CONTRACT, ON AVERAGE AT LEAST 75% OF THE EMPLOYEES WORKING ON THE PROJECT BEING BID ARE RESIDENTS OF WEST VIRGINIA WHO HAVE RESIDED IN THE STATE CONTINUOUSLY FOR THE TWO YEARS IMMEDIATELY PRECEDING SUBMISSION OF THIS BID;</p> <p>OR</p> <p>() BIDDER IS A NONRESIDENT VENDOR EMPLOYING A MINIMUM OF ONE HUNDRED STATE RESIDENTS OR IS A NONRESIDENT VENDOR WITH AN AFFILIATE OR SUBSIDIARY WHICH MAINTAINS ITS HEADQUARTERS OR PRINCIPAL PLACE OF BUSINESS WITHIN WEST VIRGINIA EMPLOYING A MINIMUM OF ONE HUNDRED STATE RESIDENTS WHO CERTIFIES THAT, DURING THE LIFE OF THE CONTRACT, ON AVERAGE AT LEAST 75% OF THE EMPLOYEES OR BIDDERS' AFFILIATE'S OR SUBSIDIARY'S EMPLOYEES ARE RESIDENTS OF WEST VIRGINIA WHO HAVE RESIDED IN THE STATE CONTINUOUSLY FOR THE TWO</p>						

SEE REVERSE SIDE FOR TERMS AND CONDITIONS

SIGNATURE	TELEPHONE	DATE
-----------	-----------	------

TITLE	FEIN	ADDRESS CHANGES TO BE NOTED ABOVE
-------	------	-----------------------------------

WHEN RESPONDING TO RFQ, INSERT NAME AND ADDRESS IN SPACE ABOVE LABELED 'VENDOR'



State of West Virginia
 Department of Administration
 Purchasing Division
 2019 Washington Street East
 Post Office Box 50130
 Charleston, WV 25305-0130

Request for Quotation

RFQ NUMBER
857C2050

PAGE
5

ADDRESS CORRESPONDENCE TO ATTENTION OF:
JOHN JOHNSTON 304-558-2402

VENDOR

*820131035 814-432-9347
 FRANKLIN INDUSTRIES CO
 645 ATLANTIC AVENUE
 FRANKLIN PA 16323

SHIP TO

DIVISION OF HIGHWAYS
 VARIOUS LOCALES AS INDICATED
 BY ORDER

DATE PRINTED	TERMS OF SALE	SHIP VIA	F.O.B.	FREIGHT TERMS
03/22/2007				

BID OPENING DATE: 04/18/2007 BID OPENING TIME 01:30PM

LINE	QUANTITY	UOP	CAT NO.	ITEM NUMBER	UNIT PRICE	AMOUNT
<p>YEARS IMMEDIATELY PRECEDING SUBMISSION OF THIS BID.</p> <p>BIDDER UNDERSTANDS IF THE SECRETARY OF TAX & REVENUE DETERMINES THAT A BIDDER RECEIVING PREFERENCE HAS FAILED TO CONTINUE TO MEET THE REQUIREMENTS FOR SUCH PREFERENCE, THE SECRETARY MAY ORDER THE DIRECTOR OF PURCHASING TO: (A) RESCIND THE CONTRACT OR PURCHASE ORDER ISSUED; OR (B) ASSESS A PENALTY AGAINST SUCH BIDDER IN AN AMOUNT NOT TO EXCEED 5% OF THE BID AMOUNT AND THAT SUCH PENALTY WILL BE PAID TO THE CONTRACTING AGENCY OR DEDUCTED FROM ANY UNPAID BALANCE ON THE CONTRACT OR PURCHASE ORDER.</p> <p>BY SUBMISSION OF THIS CERTIFICATE, BIDDER AGREES TO DISCLOSE ANY REASONABLY REQUESTED INFORMATION TO THE PURCHASING DIVISION AND AUTHORIZES THE DEPARTMENT OF TAX AND REVENUE TO DISCLOSE TO THE DIRECTOR OF PURCHASING APPROPRIATE INFORMATION VERIFYING THAT BIDDER HAS PAID THE REQUIRED BUSINESS TAXES, PROVIDED THAT SUCH INFORMATION DOES NOT CONTAIN THE AMOUNTS OF TAXES PAID NOR ANY OTHER INFORMATION DEEMED BY THE TAX COMMISSIONER TO BE CONFIDENTIAL.</p> <p>UNDER PENALTY OF LAW FOR FALSE SWEARING (WEST VIRGINIA CODE 61-5-3), BIDDER HEREBY CERTIFIES THAT THIS CERTIFICATE IS TRUE AND ACCURATE IN ALL RESPECTS; AND THAT IF A CONTRACT IS ISSUED TO BIDDER AND IF ANYTHING CONTAINED WITHIN THIS CERTIFICATE CHANGES DURING THE TERM OF THE CONTRACT, BIDDER WILL NOTIFY THE PURCHASING DIVISION IN WRITING IMMEDIATELY.</p> <p>BIDDER: <i>Franklin Industries</i></p> <p>DATE: <i>4-16-07</i></p>						

SEE REVERSE SIDE FOR TERMS AND CONDITIONS

SIGNATURE	TELEPHONE	DATE
TITLE	FEIN	ADDRESS CHANGES TO BE NOTED ABOVE

WHEN RESPONDING TO RFQ, INSERT NAME AND ADDRESS IN SPACE ABOVE LABELED 'VENDOR'



State of West Virginia
 Department of Administration
 Purchasing Division
 2019 Washington Street East
 Post Office Box 50130
 Charleston, WV 25305-0130

Request for Quotation

RFQ NUMBER
857C2050

PAGE
7

ADDRESS CORRESPONDENCE TO ATTENTION OF:
JOHN JOHNSTON 304-558-2402

VENDOR
*820131035 814-432-9347 FRANKLIN INDUSTRIES CO 645 ATLANTIC AVENUE FRANKLIN PA 16323

SHIP TO
DIVISION OF HIGHWAYS VARIOUS LOCALES AS INDICATED BY ORDER

DATE PRINTED	TERMS OF SALE	SHIP VIA	F.O.B.	FREIGHT TERMS
03/22/2007				

BID OPENING DATE: **04/18/2007** **BID OPENING TIME 01:30PM**

LINE	QUANTITY	UOP	CAT NO.	ITEM NUMBER	UNIT PRICE	AMOUNT
<p>BID OPENING DATE AND TIME</p> <p>PLEASE PROVIDE A FAX NUMBER IN CASE IT IS NECESSARY TO CONTACT YOU REGARDING YOUR BID:</p> <p style="text-align: center;">----- <i>814-432-7556</i> -----</p> <p>CONTACT PERSON (PLEASE PRINT CLEARLY):</p> <p style="text-align: center;">----- <i>James Young</i> -----</p> <p>***** THIS IS THE END OF RFQ 857C2050 ***** TOTAL: _____</p>						

SEE REVERSE SIDE FOR TERMS AND CONDITIONS

SIGNATURE	TELEPHONE	DATE
-----------	-----------	------

TITLE	FEIN	ADDRESS CHANGES TO BE NOTED ABOVE
-------	------	-----------------------------------

WHEN RESPONDING TO RFQ, INSERT NAME AND ADDRESS IN SPACE ABOVE LABELED 'VENDOR'

SCOPE OF CONTRACT

The purpose of this Contract shall be to supply WVDOH maintenance personnel with galvanized u-channel for standard maintenance, and various accessories designed to aid in the installation/removal of u-channel supports and to enhance the performance of u-channel supports.

SPECIFICATIONS FOR ITEMS

Galvanized u-channel supports (Items 1-31): Acceptance of u-channel supports supplied as part of this Contract shall be in accordance with the normal WVDOH acceptance procedures. U-channel posts are to be of a material that meets the requirements of Section 657 of the West Virginia Division of Highways' Standard Specifications For Roads and Bridges, latest edition. U-channel posts shall meet the shape and dimensional requirements shown on Sheet TE1-7A of the WVDOH, Standard Details Book, Volume 2, latest edition. Post lengths shall be as specified with a tolerance of +/- one (1) inch. Galvanized posts are to be galvanized in accordance with ASTM Specification A123.

12" X 6" U-channel anchor plate and 12" X 6" U-channel anchor plate with stabilizer (Items 32 and 33): The anchor plate shall be manufactured of A36 steel, and shall be galvanized in accordance with ASTM A563, G-90, Structural Quality, Grade 50, Class I. The plate shall attach to the post by using locking hook bolts. The plate shall be 1/8" thick by 6" tall and shall measure 12" and 6" long on the top and bottom, respectively. The general design of the anchor plate and hook bolts shall be in accordance with the attached drawing.

Manual drive cap for 3# and 4# u-channel (Item 34): The drive cap shall be a DCH17 - Big Boy Protective Drive Cap for use with 2#, 3#, and 4# u-channel.

Manual U-channel Removal Tool (Item 35): The removal tool shall be a one-piece device, with the exception of a replaceable hardened steel engagement pin. The tool handle shall be manufactured of 4130 steel. The tool shall be capable of removing 2#, 3#, and 4# posts driven to within four (4) inches of the top of soil, and shall be capable of exerting an upward force of 4,000 #. The tool shall be approximately 48" in overall length and shall weigh approximately 15 lbs. The design of the tool shall be in general conformance with the attached drawing.

Side Mounting Bracket (Item 36): Each unit of the "Side Mounting Bracket Kit" item shall include two (2) ea. brackets. The brackets shall enable the user to mount an additional sign(s) onto a 2#, 3#, or 4# post perpendicular to the sign(s) mounted to the front of the post. Each bracket shall be manufactured of steel, and shall be galvanized in accordance with ASTM specification A123. The dimensioning of the bracket shall be in accordance with the attached detail drawing.

PURCHASE HISTORY REPORTS

As part of this Contract, the vendor shall be required to submit semi-annual purchase history reports to the WVDOH. The vendor should submit this report in a summarized spreadsheet format. The spreadsheet columns should be labeled in general conformance to the following:

PO NUMBER (*Use VISA doc. number if purchased on P-card*)

PURCHASE METHOD (*Indicate "Blanket Release Order" or "P-card"*)

QTY. LINE ITEM 1 ORDERED

QTY. LINE ITEM 2 ORDERED

.

.

.

QTY LINE ITEM "N" ORDERED (*N = number of line items on Contract*)

SHIPPING DESTINATION (*Indicate the city or town the order was shipped to*)

TOTAL VALUE OF ORDER

Each report shall include summary totals of the quantity of each line item ordered and the total value of all orders placed for both the period that the report covers and from the original effective date of the Contract. After award of the Contract, the first report the Vendor will be required to submit shall be for the first 180 days of the Contract, beginning at the original effective date of the Contract. The next report shall be for the period between the end of the period covered by the first report and the expiration date of the Contract, or the effective renewal date of the Contract. Reports shall continue to be submitted as described above for the life of the Contract. The due date for submission of reports shall be 15 days after the last day of the period covered by the report.

Preferably, the Vendor should submit all reports in Microsoft Excel format to Ted Whitmore's attention at e-mail address twhitmore@@dot.state.wv.us. However, the Vendor may also submit reports to Ted Whitmore's attention at fax number 304-558-1209, or the following address:

WVDOH-Traffic Engineering Division

Bldg. 5 – Rm. A550

1900 Kanawha Blvd. East

Charleston, WV 25305

The Vendors reports shall include all purchases made, regardless of method of order placement (phone, fax, mail, internet). Failure to submit the above described reports may be grounds for cancellation of this Contract, and/or may result in a Vendor Complaint being registered with the State Purchasing Division.

MINIMUM ORDERS

When ordering Items listed on lines 1 through 31, the total combined material ordered, based on these Item numbers, shall be a minimum of 24,000 lbs.

There shall be no minimum order requirement for all other items on the contract.

DELIVERY

The supplier shall be allowed sixty (60) calendar days A.R.O. for delivery. The WVDOH shall assess liquidating damages against the supplier for each day that any delivery of material is delayed beyond the sixty (60) day limit. The District may waive a portion or all of the late delivery charges at their discretion provided an ample supply of material is in stock at the District.

The total amount of the liquidating damages shall be \$490 per day, per order, and is in accordance with Section 108.7 of the West Virginia Standard Specifications, Roads and Bridges.

The vendor must notify the receiving District a minimum of 72 hours (3 working days) prior to delivery.

The following estimated quantities are for bid purposes only. Actual quantities will be determined by needs of the West Virginia Division of Highways and may be increased or decreased.

Item Number	Estimated Quantity	Description	Unit Cost	Total Cost	Inventory Class / Type / Subcode (DOH Use Only)
1	700	Galvanized U-Channel, 2 # per foot, 4 foot long	6.96	4872.	019 014 200004
2	10	Galvanized U-Channel, 2 # per foot, 5 foot long	8.20	82.	019 014 200005
3	300	Galvanized U-Channel, 2 # per foot, 6 foot long	9.84	2952.	019 014 200006
4	1100	Galvanized U-Channel, 2 # per foot, 7 foot long	11.48	12628.	019 014 200007
5	2000	Galvanized U-Channel, 2 # per foot, 8 foot long	13.12	26240.	019 014 200008
6	10	Galvanized U-Channel, 2 # per foot, 9 foot long	14.76	147.60	019 014 200009
7	2000	Galvanized U-Channel, 2 # per foot, 10 foot long	16.40	32800.	019 014 200010
8	10	Galvanized U-Channel, 2 # per foot, 11 foot long	18.04	180.40	019 014 200011
9	10	Galvanized U-Channel, 2 # per foot, 12 foot long	19.68	196.80	019 014 200012
10	10	Galvanized U-Channel, 2 # per foot, 20 foot long	37.58	375.80	019 014 200020
11	6100	Galvanized U-Channel, 3 # per foot, 4 foot long	10.04	61244.	019 014 300004
12	10	Galvanized U-Channel, 3 # per foot, 5-1/2 foot long	12.98	129.80	019 014 300055
13	10	Galvanized U-Channel, 3 # per foot, 6 foot long	14.16	141.60	019 014 300006
14	500	Galvanized U-Channel, 3 # per foot, 7 foot long	16.52	8260.	019 014 300007
15	10	Galvanized U-Channel, 3 # per foot, 8 foot long	18.88	188.80	019 014 300008
16	1900	Galvanized U-Channel, 3 # per foot, 9 foot long	21.24	40356.	019 014 300009
17	2700	Galvanized U-Channel, 3 # per foot, 10 foot long	23.60	63720.	019 014 300010
18	800	Galvanized U-Channel, 3 # per foot, 11 foot long	25.96	20768.	019 014 300011
19	700	Galvanized U-Channel, 3 # per foot, 12 foot long	28.32	19824.	019 014 300012
20	10	Galvanized U-Channel, 3 # per foot, 13 foot long	30.68	306.80	019 014 300013
21	10	Galvanized U-Channel, 3 # per foot, 14 foot long	33.04	330.40	019 014 300014
22	10	Galvanized U-Channel, 3 # per foot, 16 foot long	37.76	377.60	019 014 300016
23	10	Galvanized U-Channel, 3 # per foot, 18 foot long	48.64	486.40	019 014 300018
24	10	Galvanized U-Channel, 3 # per foot, 20 foot long	54.04	540.40	019 014 300020
25**	10	Galvanized U-Channel, 4 # per foot, 4 foot long	13.44	134.36	019 014 400004
26**	10	Galvanized U-Channel, 4 # per foot, 6 foot long	18.35	183.54	019 014 400006
27**	10	Galvanized U-Channel, 4 # per foot, 12 foot long	36.71	367.10	019 014 400012
28**	10	Galvanized U-Channel, 4 # per foot, 14 foot long	42.83	428.30	019 014 400014
29**	10	Galvanized U-Channel, 4 # per foot, 16 foot long	48.94	489.40	019 014 400016
30**	10	Galvanized U-Channel, 4 # per foot, 18 foot long	63.04	630.40	019 014 400018
31**	10	Galvanized U-Channel, 4 # per foot, 20 foot long	70.04	700.40	019 014 400020

Total combined wt. of these items must be 24,000# min.

** 4# per foot u-channel, 4# back to back u-channel, and 6# back to back u-channel supports, without an approved slip base or breakaway ground connection, are allowed to be installed only where the speed limit is 35 MPH or less, behind guardrail, or outside the "clear zone" as defined in the AASHTO Roadside Design Guide. Also, when using 3 or more 2# or 3# u-channel posts for an assembly, post spacing must be greater than 3-1/2 ft.

NOTE: Vendors can complete Bid Schedule at Purchasing's Web Site www.state.wv.us/admin/purchase

Note: Bid per specifications attached.
18' - 20' posts only punched 16'.

Item Number	Estimated Quantity	Description	Unit Cost	Total Cost	Inventory Class / Type / Subcode (DOH Use Only)
32	5	12" x 6" u-channel anchor plate	No Bid		019 008 080205
33	5	12" x 6" u-channel anchor plate with stabilizer	No Bid		019 008 080205
34	10	Manual Drive Cap, 2#, 3#, and 4# u-channel	No Bid		019 008 080310
35	5	Manual U-channel Removal Tool	No Bid		019 008 080340
36	5	Side Mounting Bracket Kit	No Bid		019 008 080547
37	10	Per each, 2# to 4# U-Channel Anchor Mechanical Driving Tool, to include Driving Head and 4-1/4" x 7/8" Shank, for use with Atlas Copco Pionjar	No Bid		019 008 080436
38	10	Per each, 2# to 4# U-Channel Anchor Mechanical Driving Tool, to include Driving Head and 6" x 1-1/4" Shank, for use with Skidril BG231 and Atlas Copco Cobra MK-1 or FB-60	No Bid		019 008 080433
CONTRACT TOTAL				→	300081.90

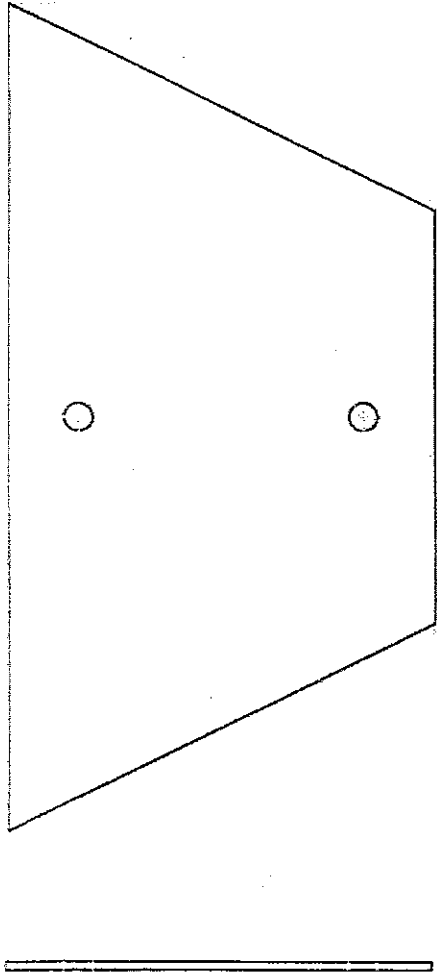
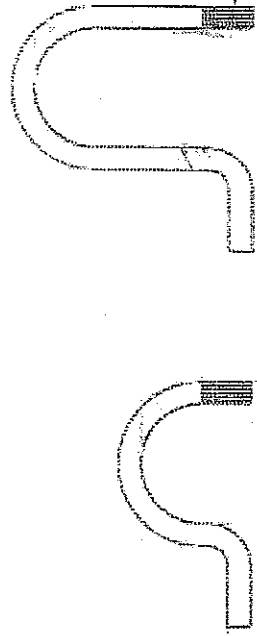

PLATE SIDE
VIEW

PLATE FRONT VIEW



LOCKING HOOK BOLTS

ITEMS 32 AND 33

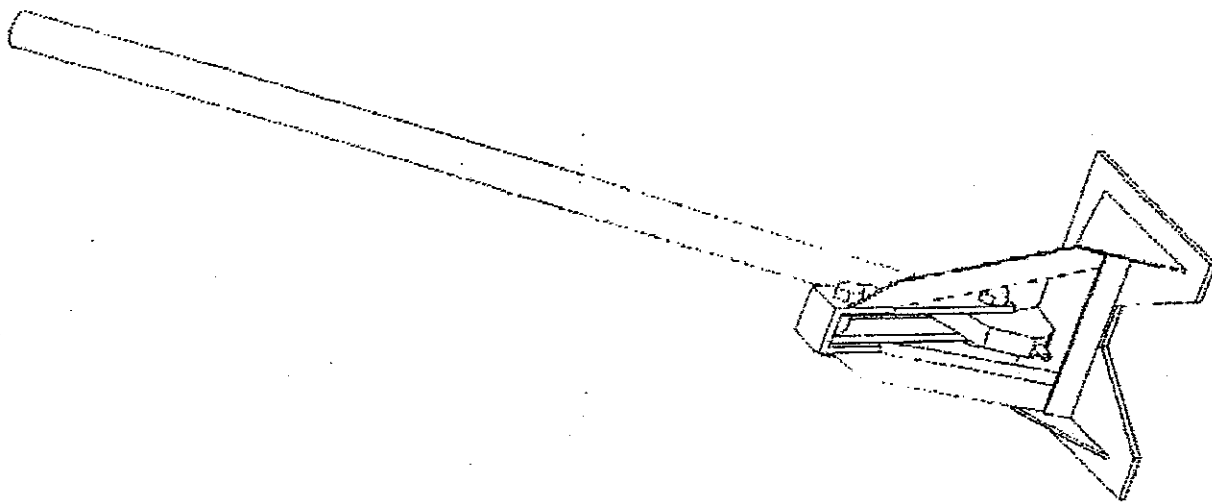

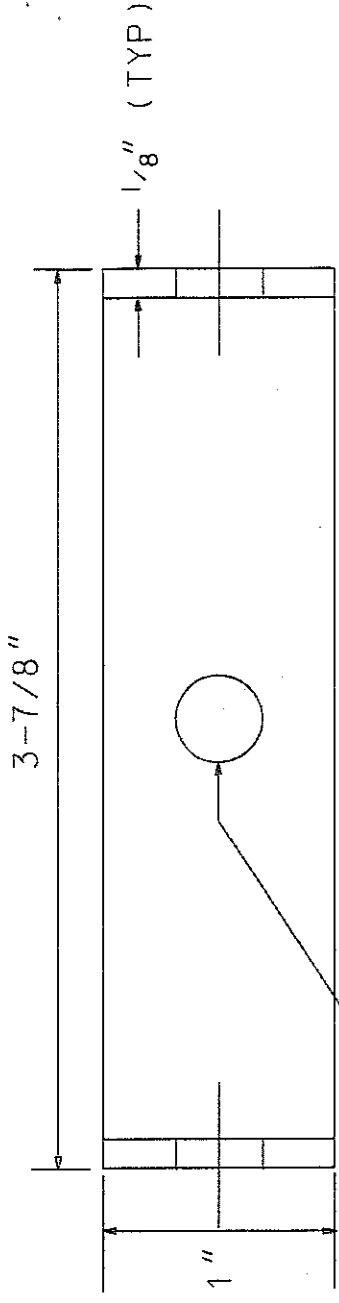

FRONT VIEW

3/8" DIAMETER HOLE
 CENTERED
 VERTICALLY AND
 HORIZONTALLY
 (TYP)

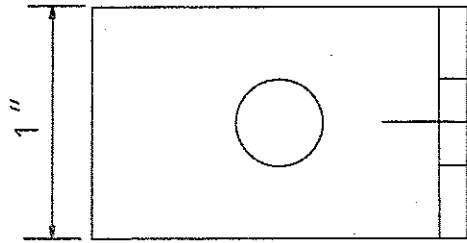

SIDE VIEW

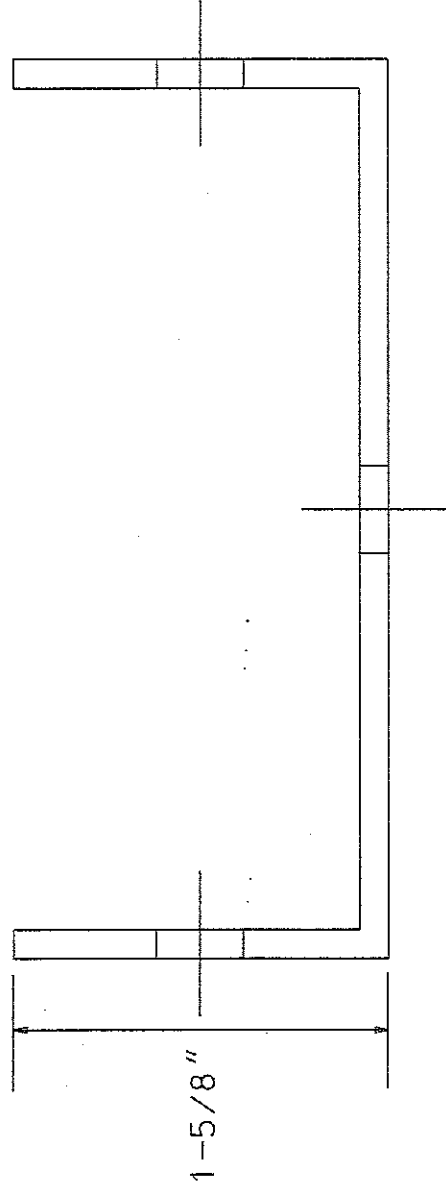

TOP VIEW

CONTACT PERSON AND DELIVERY ADDRESS FOR EACH
DIVISION OF HIGHWAYS DESTINATION

Delivery Address	Contact	Phone Number
WVDOH - D1 Sign Shop Pickens Rd. Nitro, WV 25143	Jim Russell	304-759-0708 304-558-3001*
WVDOH - D2 Sign Shop 801 Madison Ave. Huntington, WV 25704	Ed Layman	304-528-5679 304-528-5600*
WVDOH - D3 Sign Shop 720 Depot St. Parkersburg, WV 26101	Tom Potts	304-420-4815 304-420-4645*
WVDOH - D4 Sign Shop US-19 - 1 mile N. of Clarksburg (gore yard) Clarksburg, WV 26301	Rick Reed	304-627-2401 304-842-1500*
WVDOH - D5 Sign Shop US-50 - 14 miles E. of Keyser Burlington, WV 26710	Doug Placka	304-289-3521 304-289-3521*
WVDOH - D6 Sign Shop US-40 - E. of Wheeling (Middle Creek Rd. 39) Triadelphia, WV 26059	Jim Wurtzbacher	304-238-1205 304-238-4008*
WVDOH - D7 Sign Shop US-33 - 1/2 mile E. of Weston Weston, WV 26452	Tyrone Campbell	304-269-0460 304-269-0414*
WVDOH - D8 Sign Shop Rt. 219 - 1 mile N. of Elkins Elkins, WV 26241	Mike Westfall	304-637-0215 304-637-0220*
WVDOH - D9 Sign Shop US-219 - 1-1/2 miles N. of Lewisburg Country Club Rd. - Brush Rd. Lewisburg, WV 24901	Harry Honaker	304-647-7551 304-647-7450*
WVDOH - D10 Sign Shop 270 Hardwood Lane Princeton, WV 24740	Curtis Whitlow	304-487-5283 304-487-5228*
WVDOH - Traffic Services Complex 180 Dry Branch Rd. Charleston, WV 25306	Richard Rawling Ted Whitmore	304-558-6356 304-558-9468

* District/Division headquarters phone number



Specifications

Franklin Industries Co.'s Famous Gold Crown and Green/Light Grey Fence Posts are made from High-Strength Rail Steel and coated with high quality enamel paints to last years longer than other posts in the field. Even unfinished posts, used in silt fences, orchards, and vineyards, benefit from rail steel's inherent weathering resistance. For posts that will last for decades, hot dip galvanizing is also available.

Studded "T" Post

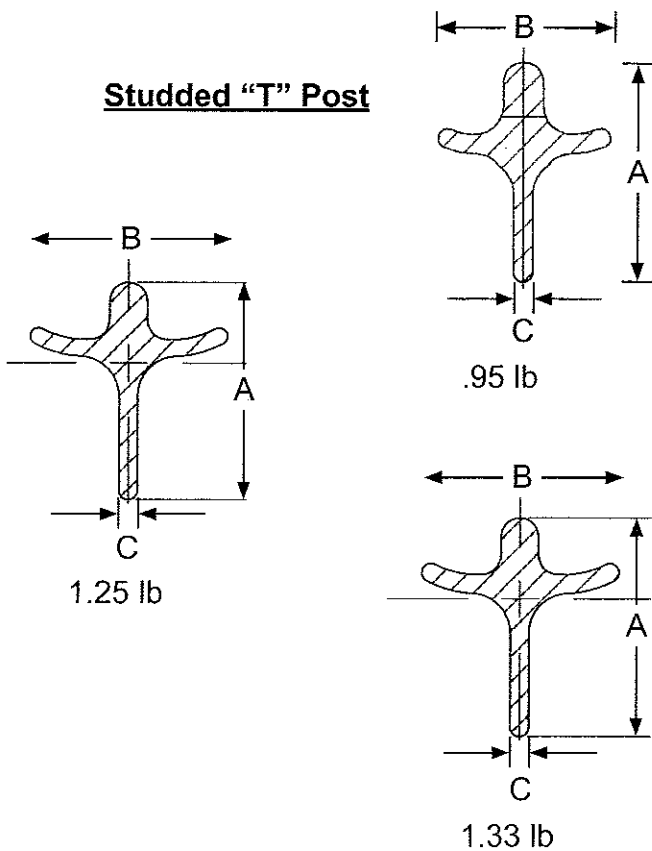

Material: Posts are produced from standard "T" rails weighing 91 lbs/yd or more according to ASTM A499, Grade 60; or ASTM A702 (1.33 lbs/ft only).

Finish: Posts are either painted with baked green enamel, hot dip galvanized per ASTM A123, or unfinished.

Studded "T" Posts: The weight of each post is 0.95, 1.25 or 1.33 lbs/ft. Studs are spaced uniformly along the length of the "T" shaped post.

Self-Fastening "U" Posts: The weight is 1.12 lbs/ft. Lugs and holes are punched for easy wire attachment along the length of the "U" shaped post.

Anchor Plates: Standard on 1.25 and 1.33 lbs/ft Studded "T" Posts, securely swaged on the studs, and on 1.12 Self Fastening "U" Posts attached with rivets.

Wire Fasteners: Five pre-formed wire fasteners are included with each painted "T" post. Fasteners are not required with "U" Posts.

Bundling: Painted posts are banded in 5 piece subbundles in 200 piece master bundles, on blocking.

Self Fastening "U" Post

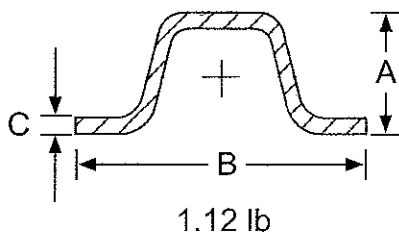

Studded "T" Post Properties

Weight Lbs/ft	Dimensions (Nominal)			Area Inch ²
	"A"	"B"	"C"	
0.95	1.465	1.125	0.125	0.279
1.25	1.625	1.375	0.125	0.368
1.33	1.635	1.375	0.130	0.391

Self Fastening "U" Post Properties

Weight	Dimensions (Nominal)			Area
1.12	0.841	2.037	0.112	0.329

High Strength Steel Sign Posts



Franklin Flanged Channel Sign Posts are manufactured from high quality, high tensile rail steel and finished with a protective coating of weather resistant baked enamel paint, or galvanized by hot dipping per ASTM A123. They are designed to provide an attractive appearance and years of maintenance-free service. Special colors and finishes can be supplied for special applications.

With Franklin Sign Posts' great strength and rigidity, you can support the same load with a lighter weight post. And with four different sign post weights and two delineator weights available, you can select the exact post to meet each requirement, buying only the steel needed to do the job. One person can install or replace a complete post and sign assembly in minutes. No digging, drilling or concrete to mix.

Recommended for Warning, Regulatory and Guide Signs

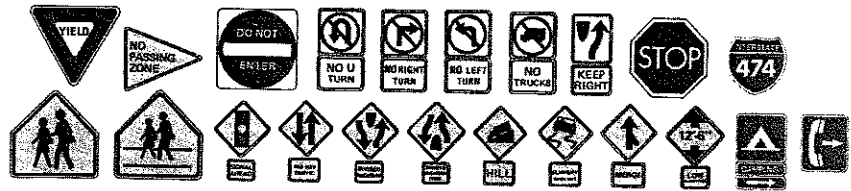

Eze-Erect Sign Post System

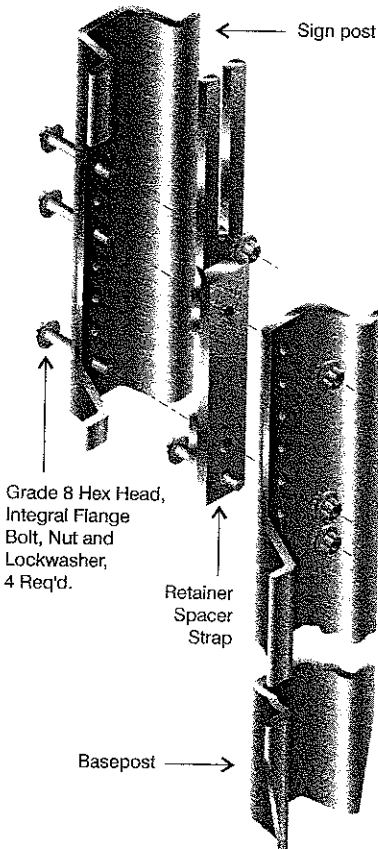

Eze-Erect sign posts' design permits quick and easy installations from ground level with simple tools. The base posts are readily driven into hard soils, even asphalt. The sign post is then attached with the sign already in place. Crews are quickly trained and most installations take only minutes.

Connection Strength

Eze-Erect sign posts' connection develops the full design strength of the sign post; there is no compromise in sign supporting capability.

Full Versatility

A complete range of warning, regulatory and guide signs can be supported, from small signs on single posts to very large signs or sign clusters on multiple posts. Eze-Erect sign posts also work well for construction and temporary signing. Whatever your highway message, Eze-Erect sign posts can hold it reliably.

Low Labor Costs/High Salvage Value

When impacted, base posts, sign posts and sign panels are often reusable. Even if damaged, sign posts can often be cut into base posts. And more importantly, because of the breakaway action, expensive sign panels, the major cost component of a sign installation are more likely to be reusable.

Widely Accepted

Hundreds of thousands of Eze-Erect sign posts are in use throughout the country. Try this proven system in your area and see how Eze-Erect sign posts can save you money.





Base-Bolted Sign Post System

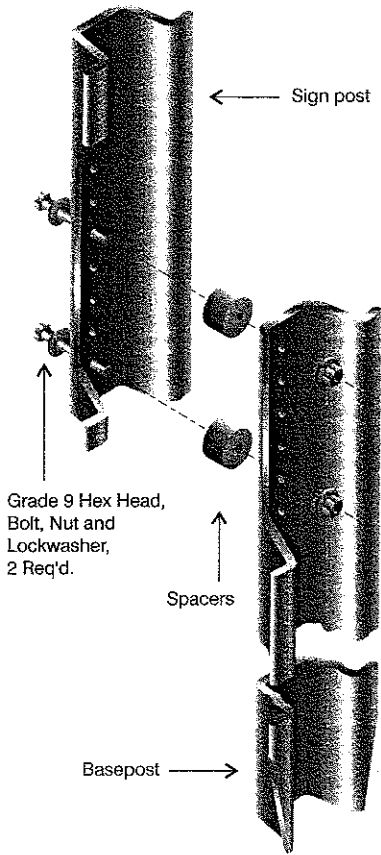

Franklin Industries' base-bolted sign posts offer many of the advantages of Eze-Erect sign posts at lower cost, except there is no retaining feature. They are an economical alternative when this feature is not required.

Connection Strength

The base-bolted connection develops the full design strength of the sign post; so comparable signs can be supported reliably.

Full Versatility

Base-bolted sign posts will support any type of warning, regulatory or guide signs, from small signs on single posts to very large signs or sign clusters on

multiple posts. Base-bolted sign posts also work well for construction and temporary signing. Franklin Industries' base-bolted sign posts can hold your sign dependably, whatever the message.

Low Labor Costs/High Salvage Value

Base posts, sign posts and sign panels are often reusable after impact with an errant vehicle. If damaged, sign posts can often be cut into base posts. But more importantly, because of the breakaway action, expensive sign panels, the major cost component of a sign installation, can most likely be reused.

NCHRP Report 350 Compliant

FHWA has accepted Franklin Industries sign posts in single and multiple post installations for all Federal-aid routes and projects.



Accessories

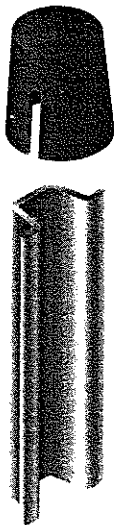

Drive Caps



Studded "T" Posts

Drive Caps For Safe Installation

Protect post ends from driving damage. Driving caps are made of cast steel to withstand constant driving. Available in sizes to fit all Franklin Industries Posts.

Delineator - 3.0 lbs ea., for 1.12 to 1.33 lbs/ft posts
 Standard - 11 lbs ea., for 2.0 to 4.0 lbs/ft posts
 Heavy Duty - 17 lbs ea., for 2.0 to 4.0 lbs/ft posts

Right-of-Way and Silt Fence Posts

Franklin Studded 'T' Posts are designed for easy installation and trouble free service for right of way and silt fencing. Heavy anchor plates protect against natural "lifting" and vandalism. They are available in 1.25 and 1.33 lbs/ft (ASTM A702) and are either painted or galvanized.

AFFIDAVIT

West Virginia Code §5A-3-10a states:

No contract or renewal of any contract may be awarded by the state or any of its political subdivisions to any vendor or prospective vendor when the vendor or prospective vendor or a related party to the vendor or prospective vendor is a debtor and the debt owned is an amount greater than one thousand dollars in the aggregate

DEFINITIONS:

"Debt" means any assessment, premium, penalty, fine, tax or other amount of money owed to the state or any of its political subdivisions because of a judgment, fine, permit violation, license assessment, defaulted workers' compensation premium, penalty or other assessment presently delinquent or due and required to be paid to the state or any of its political subdivisions, including any interest or additional penalties accrued thereon.

"Debtor" means any individual, corporation, partnership, association, limited liability company or any other form or business association owing a debt to the state or any of its political subdivisions. "Political subdivision" means any county commission; municipality; county board of education; any instrumentality established by a county or municipality; any separate corporation or instrumentality established by one or more counties or municipalities, as permitted by law; or any public body charged by law with the performance of a government function or whose jurisdiction is coextensive with one or more counties or municipalities. "Related party" means a party, whether an individual, corporation, partnership, association, limited liability company or any other form or business association or other entity whatsoever, related to any vendor by blood, marriage, ownership or contract through which the party has a relationship of ownership or other interest with the vendor so that the party will actually or by effect receive or control a portion of the benefit, profit or other consideration from performance of a vendor contract with the party receiving an amount that meets or exceed five percent of the total contract amount.

EXCEPTION:

The prohibition of this section does not apply where a vendor has contested any tax administered pursuant to chapter eleven of this code, workers' compensation premium, permit fee or environmental fee or assessment and the matter has not become final or where the vendor has entered into a payment plan or agreement and the vendor is not in default of any of the provisions of such plan or agreement.

LICENSING:

Vendors must be licensed and in good standing in accordance with any and all state and local laws and requirements by any state or local agency of West Virginia, including, but not limited to, the West Virginia Secretary of State's Office, the West Virginia Tax Department, West Virginia Insurance Commission, or any other state agencies or political subdivision. Furthermore, the vendor must provide all necessary releases to obtain information to enable the Director or spending unit to verify that the vendor is licensed and in good standing with the above entities.

CONFIDENTIALITY:

The vendor agrees that he or she will not disclose to anyone, directly or indirectly, any such personally identifiable information or other confidential information gained from the agency, unless the individual who is the subject of the information consents to the disclosure in writing or the disclosure is made pursuant to the agency's policies, procedures and rules. Vendors should visit www.state.wv.us/admin/purchase/privacy for the Notice of Agency Confidentiality Policies.

Under penalty of law for false swearing (West Virginia Code, §61-5-3), it is hereby certified that the vendor acknowledges the information in this said affidavit and are in compliance with the requirements as stated.

Vendor's Name: Franklin Industries

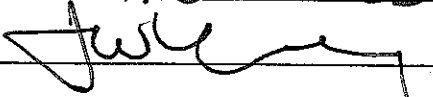
Authorized Signature:  Date: 4-16-07