



State of West Virginia  
 Department of Administration  
 Purchasing Division  
 2019 Washington Street East  
 Post Office Box 50130  
 Charleston, WV 25305-0130

# Request for Quotation

RFQ NUMBER  
**707EC016**

PAGE  
**1**

ADDRESS CORRESPONDENCE TO ATTENTION OF  
**JOHN JOHNSTON  
 304-558-2402**

VENDOR

\*709014709      304-756-2800  
**ANDERSON EQUIPMENT COMPANY**  
**PO BOX 3109**  
  
**CHARLESTON WV 25331**

SHIP TO

**DIVISION OF HIGHWAYS  
 EQUIPMENT DIVISION  
 ROUTE 33  
 BRUSHY FORK ROAD  
 BUCKHANNON, WV  
 26201      304-472-1750**

DATE PRINTED	TERMS OF SALE	SHIP VIA	FOB	FREIGHT TERMS
01/14/2007	Net 30	Anderson Arrange.	Buckhannon, WV	Delivered
BID OPENING DATE: 02/28/2007		BID OPENING TIME 01:30PM		

LINE	QUANTITY	UOP	CAT NO.	ITEM NUMBER	UNIT PRICE	AMOUNT
0001	1	EA		020-68		\$96,322.00/ea.
<b>75 HORSEPOWER TRACTOR/DOZER WITH WINCH AND BLADE</b>  <b>REBID</b>  <b>OPEN END CONTRACT</b>  <b>TO PROVIDE 75 HORSEPOWER TRACTOR/DOZER WITH WINCH AND BLADE AS DESCRIBED IN IN THE ATTACHED PROCUREMENT SPECIFICATION 300-2-C.</b>  <b>THERE WILL BE A MANDATORY PRE-BID CONFERENCE AT THE STATE CAPITOL COMPLEX, BUILDING 15, CONFERENCE ROOM, AT 10:30 AM ON 02/14/2007. FAILURE TO ATTEND THE PRE-BID CONFERENCE WILL RESULT IN BID DISQUALIFICATION.</b>  <b>QUESTIONS: WRITTEN QUESTIONS WILL BE ACCEPTED THROUGH CLOSE OF BUSINESS (5:00 PM EST) ON WEDNESDAY, 01/31/2007.</b>  <b>SEND YOUR QUESTIONS TO: PURCHASING DIVISION          ATTENTION: JOHN JOHNSTON          2019 WASHINGTON STREET EAST          CHARLESTON, WV 25305</b>  <b>QUESTIONS MAY BE SENT VIA FAX, E-MAIL OR REGULAR MAIL          E-MAIL: JJOHNSTON@WVADMIN.GOV          FAX: 304-558-4115</b>  <b>IT IS THE VENDORS RESPONSIBILITY TO VERIFY THAT THEIR QUESTIONS HAVE BEEN RECEIVED BY CALLING 304-558-2402.</b>						

SEE REVERSE SIDE FOR TERMS AND CONDITIONS

SIGNATURE <i>Michael K. Burke / tbs</i>	TELEPHONE 304-756-2800	DATE February 28, 2007
TITLE General Manager-WV	FAX 25-032-3970	ADDRESS CHANGES TO BE NOTED ABOVE

WHEN RESPONDING TO RFQ, INSERT NAME AND ADDRESS IN SPACE ABOVE LABELED 'VENDOR'



State of West Virginia  
 Department of Administration  
 Purchasing Division  
 2019 Washington Street East  
 Post Office Box 50130  
 Charleston, WV 25305-0130

# Request for Quotation

RFQ NUMBER  
**707EC016**

PAGE  
**2**

ADDRESS CORRESPONDENCE TO ATTENTION OF:  
**JOHN JOHNSTON  
 304-558-2402**

VENDOR

\*709014709      304-756-2800  
**ANDERSON EQUIPMENT COMPANY**  
**PO BOX 3109**  
  
**CHARLESTON WV 25331**

SHIP TO

**DIVISION OF HIGHWAYS  
 EQUIPMENT DIVISION  
 ROUTE 33  
 BRUSHY FORK ROAD  
 BUCKHANNON, WV  
 26201      304-472-1750**

DATE PRINTED <b>01/14/2007</b>	TERMS OF SALE	SHIP VIA	F.O.B.	FREIGHT TERMS
-----------------------------------	---------------	----------	--------	---------------

BID OPENING DATE: **02/28/2007**      BID OPENING TIME **01:30PM**

LINE	QUANTITY	UOP	CAT. NO.	ITEM NUMBER	UNIT PRICE	AMOUNT
<p><b>EXHIBIT 2</b></p> <p><b>LIFE OF CONTRACT:</b> THIS CONTRACT BECOMES EFFECTIVE ON ..... AND EXTENDS FOR A PERIOD OF ONE (1) YEAR OR UNTIL SUCH "REASONABLE TIME" THEREAFTER AS IS NECESSARY TO OBTAIN A NEW CONTRACT OR RENEW THE ORIGINAL CONTRACT. THE "REASONABLE TIME" PERIOD SHALL NOT EXCEED TWELVE (12) MONTHS. DURING THIS "REASONABLE TIME" THE VENDOR MAY TERMINATE THIS CONTRACT FOR ANY REASON UPON GIVING THE DIRECTOR OF PURCHASING THIRTY (30) DAYS WRITTEN NOTICE.</p> <p><b>UNLESS SPECIFIC PROVISIONS ARE STIPULATED IN THIS CONTRACT DOCUMENT, THE TERMS, CONDITIONS, AND PRICING SET HEREIN ARE FIRM FOR THE LIFE OF THE CONTRACT.</b></p> <p><b>RENEWAL:</b> THIS CONTRACT MAY BE RENEWED UPON THE MUTUAL WRITTEN CONSENT OF THE SPENDING UNIT AND VENDOR, SUBMITTED TO THE DIRECTOR OF PURCHASING THIRTY (30) DAYS PRIOR TO THE EXPIRATION DATE. SUCH RENEWAL SHALL BE IN ACCORDANCE WITH THE TERMS AND CONDITIONS OF THE ORIGINAL CONTRACT AND SHALL BE LIMITED TO TWO (2) ONE (1) YEAR PERIODS.</p> <p><b>CANCELLATION:</b> THE DIRECTOR OF PURCHASING RESERVES THE RIGHT TO CANCEL THIS CONTRACT IMMEDIATELY UPON WRITTEN NOTICE TO THE VENDOR IF THE COMMODITIES AND/OR SERVICES SUPPLIED ARE OF AN INFERIOR QUALITY OR DO NOT CONFORM WITH THE SPECIFICATIONS OF THE BID AND CONTRACT HEREIN.</p> <p><b>OPEN MARKET CLAUSE:</b> THE DIRECTOR OF PURCHASING MAY AUTHORIZE A SPENDING UNIT TO PURCHASE ON THE OPEN MARKET, WITHOUT THE FILING OF A REQUISITION OR COST ESTIMATE, ITEMS SPECIFIED ON THIS CONTRACT FOR IMMEDIATE DELIVERY IN EMERGENCIES DUE TO UNFORESEEN CAUSES (INCLUDING BUT NOT LIMITED TO DELAYS IN TRANSPORTATION</p>						

SEE REVERSE SIDE FOR TERMS AND CONDITIONS

SIGNATURE	TELEPHONE	DATE
TITLE	FEIN	ADDRESS CHANGES TO BE NOTED ABOVE

WHEN RESPONDING TO RFQ, INSERT NAME AND ADDRESS IN SPACE ABOVE LABELED 'VENDOR'



State of West Virginia  
 Department of Administration  
 Purchasing Division  
 2019 Washington Street East  
 Post Office Box 50130  
 Charleston, WV 25305-0130

# Request for Quotation

RFQ NUMBER
707EC016

PAGE
3

ADDRESS CORRESPONDENCE TO ATTENTION OF
JOHN JOHNSTON 304-558-2402

VENDOR

\*709014709      304-756-2800  
 ANDERSON EQUIPMENT COMPANY  
 PO BOX 3109  
 CHARLESTON WV 25331

SHIP TO

DIVISION OF HIGHWAYS  
 EQUIPMENT DIVISION  
 ROUTE 33  
 BRUSHY FORK ROAD  
 BUCKHANNON, WV  
 26201      304-472-1750

DATE PRINTED	TERMS OF SALE	SHIP VIA	F.O.B	FREIGHT TERMS
01/14/2007				

BID OPENING DATE: 02/28/2007      BID OPENING TIME 01:30PM

LINE	QUANTITY	UOP	CAT NO.	ITEM NUMBER	UNIT PRICE	AMOUNT
<p>OR AN UNANTICIPATED INCREASE IN THE VOLUME OF WORK).</p> <p>QUANTITIES: QUANTITIES LISTED IN THE REQUISITION ARE APPROXIMATIONS ONLY, BASED ON ESTIMATES SUPPLIES BY THE STATE SPENDING UNIT. IT IS UNDERSTOOD AND AGREED THAT THE CONTRACT SHALL COVER THE QUANTITIES ACTUALLY ORDERED FOR DELIVERY DURING THE TERM OF CONTRACT, WHETHER MORE OR LESS THAN THE QUANTITIES SHOWN.</p> <p>ORDERING PROCEDURE: SPENDING UNIT(S) SHALL ISSUE A WRITTEN EQUIPMENT CONTRACT ORDER (FORM NUMBER WV-35) FOR COMMODITIES COVERED BY THIS CONTRACT. THE ORIGINAL WV-35 MUST BE SENT TO THE PURCHASING DIVISION OF THE DEPARTMENT OF ADMINISTRATION. AFTER APPROVAL AND ENCUMBRANCE, ONE COPY OF THE PURCHASE ORDER WILL BE RETURNED TO THE SPENDING UNIT AND ONE COPY FORWARDED TO THE VENDOR AS AUTHORIZATION FOR SHIPMENT. NO ORDER IS VALID UNLESS APPROVED AND ENCUMBERED BY THE PURCHASING DIVISION.</p> <p>BANKRUPTCY: IN THE EVENT THE VENDOR/CONTRACTOR FILES FOR BANKRUPTCY PROTECTION, THIS CONTRACT IS AUTOMATICALLY NULL AND VOID, AND IS TERMINATED WITHOUT FURTHER ORDER.</p> <p>REV. 9/98</p> <p>EXHIBIT 6</p> <p>PRICE ADJUSTMENT PROVISION:          THE STATE OF WEST VIRGINIA WILL CONSIDER BIDS THAT CONTAIN PROVISIONS FOR PRICE ADJUSTMENTS PRIOR TO THE ORIGINAL EXPIRATION OF THE CONTRACT, PROVIDED THAT SUCH PRICE ADJUSTMENT COVERS BOTH UPWARD AND DOWNWARD MOVEMENT OF THE COMMODITY PRICE, AND THAT ADJUSTMENT I</p>						

SEE REVERSE SIDE FOR TERMS AND CONDITIONS

SIGNATURE	TELEPHONE	DATE
TITLE	FEIN	ADDRESS CHANGES TO BE NOTED ABOVE

WHEN RESPONDING TO RFQ, INSERT NAME AND ADDRESS IN SPACE ABOVE LABELED 'VENDOR'



State of West Virginia  
 Department of Administration  
 Purchasing Division  
 2019 Washington Street East  
 Post Office Box 50130  
 Charleston, WV 25305-0130

# Request for Quotation

RFQ NUMBER
707EC016

PAGE
4

ADDRESS CORRESPONDENCE TO ATTENTION OF
JOHN JOHNSTON 304-558-2402

VENDOR

\*709014709      304-756-2800  
 ANDERSON EQUIPMENT COMPANY  
 PO BOX 3109  
 CHARLESTON WV 25331

SHIP TO

DIVISION OF HIGHWAYS  
 EQUIPMENT DIVISION  
 ROUTE 33  
 BRUSHY FORK ROAD  
 BUCKHANNON, WV  
 26201      304-472-1750

DATE PRINTED	TERMS OF SALE	SHIP VIA	F.O.B	FREIGHT TERMS
01/14/2007				

BID OPENING DATE: 02/28/2007      BID OPENING TIME 01:30PM

LINE	QUANTITY	UOP	CAT NO.	ITEM NUMBER	UNIT PRICE	AMOUNT
<p>BASED ON THE "PASS THROUGH" INCREASE OR DECREASE OF RAW MATERIALS AND/OR LABOR, WHICH MAKE UP ALL OR A SUBSTANTIAL PART OF A PRODUCT. ADJUSTMENTS ARE TO BE BASED UPON AN ACTUAL DOLLAR FIGURE, NOT A PERCENTAGE. ALL PRICE ADJUSTMENT REQUESTS MUST BE SUBSTANTIATED IN A MANNER ACCEPTABLE TO THE DIRECTOR PURCHASING, E.G. GOVERNMENTAL BENCH MARKS, GENERAL MARKET INCREASE, PUBLISHED PRICE LISTS. SUCH REQUESTS FOR AND INCREASE SHOULD BE RECEIVED IN WRITING BY THE DIRECTOR OF PURCHASING AT LEAST 30 DAYS IN ADVANCE OF THE EFFECTIVE DATE OF THE INCREASE. ANY TIME THE VENDOR REQUESTS A PRICE ADJUSTMENT, THE PURCHASING DIVISION MAY EITHER ACCEPT THE PRICE ADJUSTMENT AND AMEND THE CONTRACT ACCORDINGLY OR REJECT THE ADJUSTMENT IN ITS ENTIRETY AND CANCEL THE CONTRACT.</p> <p>EXHIBIT 4</p> <p>LOCAL GOVERNMENT BODIES: UNLESS THE VENDOR INDICATES IN THE BID HIS REFUSAL TO EXTEND THE PRICES, TERMS, AND CONDITIONS OF THE BID TO COUNTY, SCHOOL, MUNICIPAL AND OTHER LOCAL GOVERNMENT BODIES, THE BID SHALL EXTEND TO POLITICAL SUBDIVISIONS OF THE STATE OF WEST VIRGINIA. IF THE VENDOR DOES NOT WISH TO EXTEND THE PRICES, TERMS, AND CONDITIONS OF THE BID TO ALL POLITICAL SUBDIVISIONS OF THE STATE, THE VENDOR MUST CLEARLY INDICATE SUCH REFUSAL IN HIS BID. SUCH REFUSAL SHALL NOT PREJUDICE THE AWARD OF THIS CONTRACT IN ANY MANNER.</p> <p>REV. 3/88</p> <p>VENDOR PREFERENCE CERTIFICATE</p> <p>CERTIFICATION AND APPLICATION* IS HEREBY MADE FOR PREFERENCE IN ACCORDANCE WITH WEST VIRGINIA CODE,</p>						

SEE REVERSE SIDE FOR TERMS AND CONDITIONS

SIGNATURE	TELEPHONE	DATE
TITLE	FEIN	ADDRESS CHANGES TO BE NOTED ABOVE

WHEN RESPONDING TO RFQ, INSERT NAME AND ADDRESS IN SPACE ABOVE LABELED 'VENDOR'



State of West Virginia  
 Department of Administration  
 Purchasing Division  
 2019 Washington Street East  
 Post Office Box 50130  
 Charleston, WV 25305-0130

# Request for Quotation

RFQ NUMBER
707EC016

PAGE
5

ADDRESS CORRESPONDENCE TO ATTENTION OF
JOHN JOHNSTON 304-558-2402

VENDOR

\*709014709      304-756-2800  
 ANDERSON EQUIPMENT COMPANY  
 PO BOX 3109  
 CHARLESTON WV 25331

SHIP TO

DIVISION OF HIGHWAYS  
 EQUIPMENT DIVISION  
 ROUTE 33  
 BRUSHY FORK ROAD  
 BUCKHANNON, WV  
 26201      304-472-1750

DATE PRINTED	TERMS OF SALE	SHIP VIA	F.O.B.	FREIGHT TERMS
01/14/2007				

BID OPENING DATE: **02/28/2007**      BID OPENING TIME **01:30PM**

LINE	QUANTITY	UOP	CAT NO	ITEM NUMBER	UNIT PRICE	AMOUNT
				5A-3-37 (DOES NOT APPLY TO CONSTRUCTION CONTRACTS).		
				A. APPLICATION IS MADE FOR 2.5% PREFERENCE FOR THE REASON CHECKED:		
				( ) BIDDER IS AN INDIVIDUAL RESIDENT VENDOR AND HAS RESIDED CONTINUOUSLY IN WEST VIRGINIA FOR FOUR (4) YEARS IMMEDIATELY PRECEDING THE DATE OF THIS CERTIFICATION; OR		
				(X) BIDDER IS A PARTNERSHIP, ASSOCIATION OR CORPORATION RESIDENT VENDOR AND HAS MAINTAINED ITS HEAD-QUARTERS OR PRINCIPAL PLACE OF BUSINESS CONTINUOUSLY IN WEST VIRGINIA FOR FOUR (4) YEARS IMMEDIATELY PRECEDING THE DATE OF THIS CERTIFICATION; OR 80% OF THE OWNERSHIP INTEREST OF BIDDER IS HELD BY ANOTHER INDIVIDUAL, PARTNERSHIP, ASSOCIATION OR CORPORATION RESIDENT VENDOR WHO HAS MAINTAINED ITS HEADQUARTERS OR PRINCIPAL PLACE OF BUSINESS CONTINUOUSLY IN WEST VIRGINIA FOR FOUR (4) YEARS IMMEDIATELY PRECEDING THE DATE OF THIS CERTIFICATION; OR		
				( ) BIDDER IS A CORPORATION NONRESIDENT VENDOR WHICH HAS AN AFFILIATE OR SUBSIDIARY WHICH EMPLOYS A MINIMUM OF ONE HUNDRED STATE RESIDENTS AND WHICH HAS MAINTAINED ITS HEADQUARTERS OR PRINCIPAL PLACE OF BUSINESS WITHIN WEST VIRGINIA CONTINUOUSLY FOR THE FOUR (4) YEARS IMMEDIATELY PRECEDING THE DATE OF THIS CERTIFICATION.		
				B. APPLICATION IS MADE FOR 2.5% PREFERENCE FOR THE REASON CHECKED:		
				( ) BIDDER IS A RESIDENT VENDOR WHO CERTIFIES THAT, DURING THE LIFE OF THE CONTRACT, ON AVERAGE AT LEAST 75% OF THE EMPLOYEES WORKING ON THE PROJECT BEING BID		

SEE REVERSE SIDE FOR TERMS AND CONDITIONS

SIGNATURE	TELEPHONE	DATE
TITLE	FEIN	ADDRESS CHANGES TO BE NOTED ABOVE

WHEN RESPONDING TO RFQ, INSERT NAME AND ADDRESS IN SPACE ABOVE LABELED 'VENDOR'



State of West Virginia  
 Department of Administration  
 Purchasing Division  
 2019 Washington Street East  
 Post Office Box 50130  
 Charleston, WV 25305-0130

# Request for Quotation

RFQ NUMBER
707EC016

PAGE
6

ADDRESS CORRESPONDENCE TO ATTENTION OF
JOHN JOHNSTON 304-558-2402

VENDOR

\*709014709      304-756-2800  
 ANDERSON EQUIPMENT COMPANY  
 PO BOX 3109  
 CHARLESTON WV 25331

SHIP TO

DIVISION OF HIGHWAYS  
 EQUIPMENT DIVISION  
 ROUTE 33  
 BRUSHY FORK ROAD  
 BUCKHANNON, WV  
 26201      304-472-1750

DATE PRINTED	TERMS OF SALE	SHIP VIA	F.O.B	FREIGHT TERMS
01/14/2007				

BID OPENING DATE: 02/28/2007      BID OPENING TIME 01:30PM

LINE	QUANTITY	UOP	CAT NO	ITEM NUMBER	UNIT PRICE	AMOUNT
<p>ARE RESIDENTS OF WEST VIRGINIA WHO HAVE RESIDED IN THE STATE CONTINUOUSLY FOR THE TWO YEARS IMMEDIATELY PRECEDING SUBMISSION OF THIS BID;            OR            ( ) BIDDER IS A NONRESIDENT VENDOR EMPLOYING A MINIMUM OF ONE HUNDRED STATE RESIDENTS OR IS A NONRESIDENT VENDOR WITH AN AFFILIATE OR SUBSIDIARY WHICH MAINTAINS ITS HEADQUARTERS OR PRINCIPAL PLACE OF BUSINESS WITHIN WEST VIRGINIA EMPLOYING A MINIMUM OF ONE HUNDRED STATE RESIDENTS WHO CERTIFIES THAT, DURING THE LIFE OF THE CONTRACT, ON AVERAGE AT LEAST 75% OF THE EMPLOYEES OR BIDDERS' AFFILIATE'S OR SUBSIDIARY'S EMPLOYEES ARE RESIDENTS OF WEST VIRGINIA WHO HAVE RESIDED IN THE STATE CONTINUOUSLY FOR THE TWO YEARS IMMEDIATELY PRECEDING SUBMISSION OF THIS BID.</p> <p>BIDDER UNDERSTANDS IF THE SECRETARY OF TAX &amp; REVENUE DETERMINES THAT A BIDDER RECEIVING PREFERENCE HAS FAILED TO CONTINUE TO MEET THE REQUIREMENTS FOR SUCH PREFERENCE, THE SECRETARY MAY ORDER THE DIRECTOR OF PURCHASING TO: (A) RESCIND THE CONTRACT OR PURCHASE ORDER ISSUED; OR (B) ASSESS A PENALTY AGAINST SUCH BIDDER IN AN AMOUNT NOT TO EXCEED 5% OF THE BID AMOUNT AND THAT SUCH PENALTY WILL BE PAID TO THE CONTRACTING AGENCY OR DEDUCTED FROM ANY UNPAID BALANCE ON THE CONTRACT OR PURCHASE ORDER.</p> <p>BY SUBMISSION OF THIS CERTIFICATE, BIDDER AGREES TO DISCLOSE ANY REASONABLY REQUESTED INFORMATION TO THE PURCHASING DIVISION AND AUTHORIZES THE DEPARTMENT OF TAX AND REVENUE TO DISCLOSE TO THE DIRECTOR OF PURCHASING APPROPRIATE INFORMATION VERIFYING THAT BIDDER HAS PAID THE REQUIRED BUSINESS TAXES, PROVIDED THAT SUCH INFORMATION DOES NOT CONTAIN THE AMOUNTS OF TAXES PAID NOR ANY OTHER INFORMATION DEEMED BY THE TAX COMMISSIONER TO BE CONFIDENTIAL.</p>						

SEE REVERSE SIDE FOR TERMS AND CONDITIONS

SIGNATURE	TELEPHONE	DATE
TITLE	FEIN	ADDRESS CHANGES TO BE NOTED ABOVE

WHEN RESPONDING TO RFQ, INSERT NAME AND ADDRESS IN SPACE ABOVE LABELED 'VENDOR'



State of West Virginia  
 Department of Administration  
 Purchasing Division  
 2019 Washington Street East  
 Post Office Box 50130  
 Charleston, WV 25305-0130

# Request for Quotation

RFQ NUMBER  
**707EC016**

PAGE  
**7**

ADDRESS CORRESPONDENCE TO ATTENTION OF  
**JOHN JOHNSTON**  
**304-558-2402**

VENDOR

\*709014709      304-756-2800  
**ANDERSON EQUIPMENT COMPANY**  
**PO BOX 3109**  
  
**CHARLESTON WV 25331**

SHIP TO

**DIVISION OF HIGHWAYS**  
**EQUIPMENT DIVISION**  
**ROUTE 33**  
**BRUSHY FORK ROAD**  
**BUCKHANNON, WV**  
**26201**      **304-472-1750**

DATE PRINTED	TERMS OF SALE	SHIP VIA	F.O.B	FREIGHT TERMS
01/14/2007				

BID OPENING DATE: **02/28/2007**      **BID OPENING TIME 01:30PM**

LINE	QUANTITY	UOP	CAT NO.	ITEM NUMBER	UNIT PRICE	AMOUNT
<p>UNDER PENALTY OF LAW FOR FALSE SWEARING (WEST VIRGINIA CODE 61-5-3), BIDDER HEREBY CERTIFIES THAT THIS CERTIFICATE IS TRUE AND ACCURATE IN ALL RESPECTS; AND THAT IF A CONTRACT IS ISSUED TO BIDDER AND IF ANYTHING CONTAINED WITHIN THIS CERTIFICATE CHANGES DURING THE TERM OF THE CONTRACT, BIDDER WILL NOTIFY THE PURCHASING DIVISION IN WRITING IMMEDIATELY.</p> <p>BIDDER: <u>Anderson Equipment Company</u></p> <p>DATE: <u>February 28, 2007</u></p> <p>SIGNED: <u>Michael K. Burke / tks</u>            Michael K. Burke</p> <p>TITLE: <u>General Manager - WV</u></p> <p>* CHECK ANY COMBINATION OF PREFERENCE CONSIDERATION(S) IN EITHER "A" OR "B", OR BOTH "A" AND "B" WHICH YOU ARE ENTITLED TO RECEIVE. YOU MAY REQUEST UP TO THE MAXIMUM 5% PREFERENCE FOR BOTH "A" AND "B". (REV. 12/00)</p> <p>NOTICE</p> <p>A SIGNED BID MUST BE SUBMITTED TO:</p> <p>DEPARTMENT OF ADMINISTRATION            PURCHASING DIVISION            BUILDING 15            2019 WASHINGTON STREET, EAST            CHARLESTON, WV 25305-0130</p>						

SEE REVERSE SIDE FOR TERMS AND CONDITIONS

SIGNATURE	TELEPHONE	DATE
TITLE	FEIN	ADDRESS CHANGES TO BE NOTED ABOVE

WHEN RESPONDING TO RFQ, INSERT NAME AND ADDRESS IN SPACE ABOVE LABELED 'VENDOR'







State of West Virginia  
 Department of Administration  
 Purchasing Division  
 2019 Washington Street East  
 Post Office Box 50130  
 Charleston, WV 25305-0130

# Request for Quotation

RFQ NUMBER  
**707EC016**

PAGE  
**9**

ADDRESS CORRESPONDENCE TO ATTENTION OF  
**JOHN JOHNSTON  
 304-558-2402**

VENDOR

\*709014709      304-756-2800  
**ANDERSON EQUIPMENT COMPANY**  
**PO BOX 3109**  
**CHARLESTON WV 25331**

SHIP TO

**DIVISION OF HIGHWAYS  
 EQUIPMENT DIVISION  
 ROUTE 33  
 BRUSHY FORK ROAD  
 BUCKHANNON, WV  
 26201      304-472-1750**

DATE PRINTED	TERMS OF SALE	SHIP VIA	F.O.B	FREIGHT TERMS
01/14/2007				

BID OPENING DATE: **02/28/2007**      **BID OPENING TIME 01:30PM**

LINE	QUANTITY	UOP	CAT NO	ITEM NUMBER	UNIT PRICE	AMOUNT
***** THIS IS THE END OF RFQ 707EC016 ***** TOTAL:						_____

SEE REVERSE SIDE FOR TERMS AND CONDITIONS

SIGNATURE	TELEPHONE	DATE
TITLE	FEIN	ADDRESS CHANGES TO BE NOTED ABOVE

WHEN RESPONDING TO RFQ, INSERT NAME AND ADDRESS IN SPACE ABOVE LABELED 'VENDOR'

WEST VIRGINIA DEPARTMENT OF TRANSPORTATION  
DIVISION OF HIGHWAYS  
EQUIPMENT DIVISION

PROCUREMENT SPECIFICATIONS  
NO. 300-2-C

75 HORSEPOWER TRACTOR/DOZER WITH WINCH AND BLADE

1.0 PURPOSE

It is the purpose of these specifications to describe a 75 Horsepower Tractor/Dozer with Winch and Blade (hereinafter referred to as a "dozer" or a "unit") to be purchased for use by the West Virginia Division of Highways (DOH) on an Open End Contract basis.

2.0 BIDDING PROCEDURES

The current purchasing procedures regarding bidding as established by the Department of Administration, Purchasing Division, shall apply. Failure to submit the "Request for Quotation" forms, complete in its entirety and according to directions indicated, may subject the bidder to disqualification. Each bid submitted shall also be accompanied by a Bidder's Evaluation Report completed in detail. Addendums in order, along with exception sheets, should be with Bidder's Evaluation Report. **FAILURE TO SUBMIT THE BIDDER'S EVALUATION REPORT, COMPLETE IN ITS ENTIRETY, MAY RESULT IN AUTOMATIC DISQUALIFICATION.**

3.0 SPECIFICATIONS

The specifications named herein, mandatory and non-mandatory, establish the acceptable level of quality only and are not intended to reflect a preference or favor any particular brand or vendor.

3.1 EXCEPTIONS TO NON-MANDATORY SPECIFICATIONS

Exception to a non-mandatory unit specification may be made by the bidder, providing the exception is not available from the manufacturer. Any such exception must be noted on the bidder's evaluation report and should be accompanied by supporting documentation/literature from the manufacturer. Any exception must be indicated on a separate attachment to the bidder's evaluation report and labeled as "Exception to Specifications". The state reserves the right to determine whether the stated exception does or does not reduce the quality and performance of the unit. Failure to provide information for any exceptions may be grounds for rejection of the bid. The state reserves the right to waive minor irregularities in bids or specifications in accordance with §148-1-4(f) of the WV Legislative Rules and Regulations.

### 3.2 MANDATORY SPECIFICATIONS

All specifications preceded by "shall and/or must" or are stated as a "minimum and/or maximum" are mandatory. Any bid failing to meet any mandatory item shall be immediately disqualified. Failure to respond in the appropriate evaluation section may also be grounds for immediate disqualification at the discretion of the State.

A mandatory pre-bid conference is scheduled for this equipment purchase as stated in the RFQ. Vendors having products with variations or exceptions in specified mandatory items are expected to address any such variations or exceptions during the pre-bid conference. The State shall review and consider any such variation or exception, and may at its sole discretion, issue an addendum to change mandatory specifications deemed to be in the State's best interest. Bids from any vendor failing to attend the mandatory pre-bid shall be disqualified. Bids containing any variation or exception to a mandatory specification that was not addressed during the pre-bid conference and accepted by the issuance of an Addendum shall be disqualified.

### 4.0 REPRESENTATIVE UNIT FOR TEST

The successful vendor must (if specified) provide DOH one (1) completed representative unit to be observed and evaluated on each order to insure compliance with specification. If requested, the time period for testing and evaluation shall be seven (7) working days following receipt of the unit. DOH will incur no obligation for deterioration of surfaces, finishes, seals, and mechanical or electrical parts on the unit resulting from operation and testing within the limits of these specifications; nor will DOH incur obligation for damage to the unit resulting from failure to meet specifications when due care and attention is given by DOH and testing is done within the limits of these specifications. Failure of the pilot unit to satisfactorily meet specifications as bid shall be cause for cancellation of the purchase order, and return of the delivered unit along with all associated equipment to the vendor at the vendor's expense.

### 4.1 CONDITION OF UNIT(S) UPON DELIVERY

All units must arrive at the prescribed delivery point having been completely preserviced with oil, lubricants, and coolant. All prescribed precautions pertaining to first operations and break-in of the unit are to be posted conspicuously on the unit for ready observance by the operator.

### 4.2 DELIVERY

Delivery point of the completely assembled representative unit will be the DOH, Equipment Division, Route 33 at Brushy Fork Road, Buckhannon, West Virginia (26201).

The vendor is responsible for guaranteeing delivery of the completed units within the time specified and agreed to by the State. Delivery is preferred within 120 days. The vendor is responsible for establishing and coordinating delivery terms with allied manufacturers or suppliers. Delivery terms shall be stated in the bid and the State reserves the right to accept or negotiate such terms. Failure to reach an agreement may result in rejection of the bid. The successful bidder shall provide their manufacturer's

confirmation of the order to the WVDOH contact person within seven (7) working days after receiving the approved purchase order.

A completed pilot model for inspection must be provided within 60 calendar days after the date of the purchase agreement by the successful vendor.

Delivery is an integral part of this specification and failure to comply will be cause to initiate a D.O.T. Administrative Form WV-82, Vendor Performance Form. The WV-82 Form will provide a means of officially notifying the Purchasing Division and the vendor of unsatisfactory performance; such as late deliveries, poor service, inadequate parts supplies, etc.

The decision to initiate subject Form will be at the sole discretion of the D.O.H. Commissioner's established Equipment Review Board.

Issuance of the WV-82 Vendor Complaint Form on unsatisfactory delivery against any vendor will be cause to refuse to consider similar items from those vendors on future Request For Quotations.

(NOTE: Delivery time could be altered due to labor strikes, severe inclement weather conditions, etc )

## 5.0 AWARD CRITERIA

- 5.1 DOH will recommend the award in accordance with the RFQ evaluation criteria described in the requisition. The award shall be made to the lowest unit cost vendor that meets or exceeds the specifications.

Prices for the units shall be in quantities of 1-10, 11-20, and 21 and over. However, for evaluation purposes, we will use quantities 1-10. DOH reserves the right to place multiple orders in any quantity.

## 6.0 SPECIFICATIONS AND GUIDELINES - GENERAL

### 6.1 IDENTIFICATION OF THE UNIT BEING PROPOSED

The bidder must identify the unit by manufacturer, model, series, and year of manufacture, in the bid to enable identification by DOH in the manufacturer's specifications of the proposed unit. The bidder will submit complete descriptive literature of the proposed unit, to establish that the bid is the manufacturer's most current model, including latest engineering improvements, which have been, or will imminently be, regularly advertised and sold on the open market. The unit specified herein and offered to be manufactured after January 1, 2007 and be clearly identified and marked with date of manufacture.

### 6.2 OPERATING AND SERVICE MANUALS AND PARTS LISTS

An operator's manual must be included with each unit upon delivery. A "line sheet" (if applicable) and Equipment Preventative Maintenance Questionnaire (as shown in X6.2 of the Bidder's Evaluation Report) must be with pilot unit upon delivery. In addition, there must be 12 service, shop, or maintenance manuals; ten (10) to be distributed to the Districts and two (2) for the Equipment Division. Also, there must be 14 parts manuals;

ten (10) to be distributed to the Districts and four (4) for Equipment Division use. CD ROM is preferred in lieu of parts manuals.

\* NOTE: MANUALS SHALL BE DELIVERED UPON COMPLETION OF DELIVERY OF TOTAL UNITS. FAILURE TO DO SO WILL DELAY PAYMENT.

6.3 TRAINING:

Manufacturers and/or dealers will be required to stage a thorough seminar on the subjects of Preventative Maintenance, Operator and Mechanic Training. In order to keep the operators and mechanics updated, the successful vendor shall conduct training with each purchase order against this open end contract. Training is preferred within 2 working days after delivery of the pilot unit on the individual purchase order.

Manufacturers and/or dealers shall be required to furnish the Training Academy with one (1) Operator's Manual.

The seminar to be held at the W. Va. Division of Highways, Equipment Division, Buckhannon, West Virginia.

6.4 PREVENTIVE MAINTENANCE AND OPERATOR PROCEDURES:

Manufacturers and/or dealers will be required to submit to the Equipment Division, in addition to the operating and service manuals, booklets and pamphlets explaining the Preventive Maintenance and Operator Procedures to be used by the operators of this equipment, and must include such things as daily prestart inspection procedure, service schedule, and routine maintenance required, safety precautions, etc.

The successful vendor shall furnish all training aids; i.e., videos, projectors, etc. required in conducting the training.

6.5 WARRANTY AND SERVICE POLICY

The Manufacturers warranty or service policy is to apply to the unit. Such warranty or service policy is to be recognized at any authorized unit dealer, representing manufacturer of proposed unit throughout the State of West Virginia. The applicable warranty or service policy will not be contingent upon obtaining routine service, lubrication, and servicing of the unit from factory authorized agencies. It will be the responsibility of the bidder to have available labor to repair or replace any defective replacement parts, components and materials, and to have available those replacement parts, components, and/or materials found to be defective during the terms of the warranty period. The bidder should state the labor rates, locations where parts will be stocked, availability of parts, and discounts offered for parts, when terms of the warranty offer a pro-rated cost for parts and labor. In addition, the successful bidder should offer field work to repair or replace defective parts, components, and materials found to be defective during the terms of the warranty and should provide mechanic's travel rates, mileage charges, field mechanic rates, and any surcharge for miscellaneous items, if applicable, for field work during the warranty period. Submit to Division of Highways any technical or engineering improvements during the term of the warranty. The unit must be accompanied upon delivery by the unit's manufacturer's executed warranty or service policy.

A mandatory minimum two (2) year bumper to bumper basic warranty is required for this unit.

\*Please list all extended service contract coverage published and not published along with cost as options and all associated information.

THE "WARRANTY AND SERVICE POLICY QUESTIONNAIRE" ATTACHED IN THE BIDDER'S EVALUATION REPORT MUST BE COMPLETED IN ITS ENTIRETY BY THE SUCCESSFUL BIDDER OR MANUFACTURER PRIOR TO DELIVERY OF THE PILOT MODEL. (SEE SECTION X6.5 OF BIDDER'S EVALUATION REPORT).

## 6.6 EVALUATION COMMITTEE REQUIREMENTS

Detailed component specifications, product literature, component models, required for specification compliance determination by the Evaluation Committee should be provided with each bid. Any information supplied that is contrary to/or conflicting with the specifications and/or attached Bidders Evaluation Report may be sufficient cause for rejection of bid.

## 6.7 UNSPECIFIED ACCESSORIES & FEATURES

All parts, equipment, accessories, material, design and performance characteristics not specified herein, but which are necessary to provide a complete unit, must be furnished with each unit and required to conform to strength, quality of material, and quality of workmanship to those which are advertised and provided to the market in general by the unit industry.

All parts and accessories advertised and regularly supplied as standard shall be included, except those which would represent duplication of these specified, and except those which, by specification, are not to be furnished. All standard safety features, required by Federal and State Law, shall be included.

## 7.0 SPECIFICATIONS OF THE QUOTED UNIT ARE AS FOLLOWS:

### 7.1 Engine:

7.1.1 Engine shall be diesel

7.1.2 Engine to be approximately 75 horsepower

7.1.3 Engine flywheel power to be approximately 70 horsepower

### 7.2 Weight:

7.2.1 Operating weight shall be minimum 15,000 lbs. to maximum 19,000 lbs.

### 7.3 Transmission:

7.3.1 Travel speed – forward: Approximately 5.6 MPH/ 9.6KM/h

7.3.2 Travel speed – reverse: Approximately 6 MPH/9.6KM/h

### 7.4 Cab/ROPS/FOPS:

7.4.1 Unit shall have fully enclosed cab with air conditioning, ROPS, FOPS, and rear screen

7.4.1.1 ROPS – Must meet SAE J397-Oct 95, SAFJ1040 May 94, ISO 3471-94, ISO 3164-95 Standards

7.4.1.2 FOPS – Must meet SAEJ231 – Jan 81, ISO 3449-Standards

### 7.5 Winch:

7.5.1 Winch shall be hydrostatic with variable control

7.5.2 Drum capacity should be about 257 feet

7.5.2.1 Winch rope diameter shall be a minimum of 5/8 inches and maximum 3/4 inches with tail chain and hook. (Must comply with winch specifications.)

7.5.3 Minimum line pull (full drum) 25,000 lbs/11340kg

7.5.4 Maximum line speed (full drum) 207 feet/min/ 63m/min.

7.5.5 Winch shall meet or exceed all OSHA safety requirements

### 7.6 Undercarriage:

7.6.1 Shoe width – 16 inches / 406 mm

7.6.2 Unit shall have standard rock guards on each end

### 7.7 Blade:

7.7.1 Unit shall have a 6-way blade.

### 7.8 Paint:

7.8.1 The dozer shall be painted manufacturer's standard

7.8.2 In order to test the adhesive quality of the paint, the DOH may, at its option, require that the vendor measure adhesion by the criteria set forth in ASTM D3359-74, Method B. A rating of less than 4 on this test would be deemed unacceptable.

- 7.8.3 The procedures used by the manufacturer in cleaning, de-greasing, priming, and painting are sufficient to meet this requirement.
- 7.8.4 The Department reserves the right to view larger paint samples after award of contract and the right to require subtle color changes. Such changes, if any, will only be used for selecting a suitable paint color to match the WV DOH logo.
- 7.9 Vendor must certify that unit offered will meet or exceed the "Occupational Safety and Health Act of 1970" or subsequent changes that are in effect at time of manufacturer of the unit.
- 7.10 Advertising: Only one (1) manufacturer name plate, which must include model number, may appear on exterior of unit. Logos created through the stamping or casting process of manufacture are also acceptable. No logo will interfere with the Department's striping and logo.
- 7.11 Preventive Maintenance and Operators Orientation/Training:
- 7.11.1 The Manufacturer or dealer shall provide preventive maintenance/operator orientation seminar to be conducted at the Equipment Division, Buckhannon. All training aids i.e. videos, charts, manuals, etc., to be furnished by successful vendor.



NOTE: Vendors should type Bidder's Evaluation report

WEST VIRGINIA DEPARTMENT OF TRANSPORTATION  
DIVISION OF HIGHWAYS  
EQUIPMENT DIVISION

BIDDER'S EVALUATION REPORT

PROCUREMENT SPECIFICATIONS FOR OPEN END CONTRACT  
NO. 300-2-C

75 HORSEPOWER TRACTOR/DOZER WITH WINCH AND BLADE

NOTE TO BIDDER: Procurement Specification No. 300-2-C, Paragraph 2.0 recommends the completion and submittal of this Report with your bid. Purpose of this Report is to enable the West Virginia Division of Highways Evaluation Committee to make full and fair evaluation of the bid. Addendums in order, along with exception sheets, should be with Bidder's Evaluation Report.

FAILURE TO SUBMIT THIS REPORT, COMPLETE IN ITS ENTIRETY, MAY SUBJECT THE BIDDER TO DISQUALIFICATION.

Reference Requisition No.: 707EC016

Bidder's Name: Anderson Equipment Company

Address: P. O. Box 3109, Charleston, WV 25331

Telephone Number: 304-756-2800

Years Bidder has been registered to do business with the State of West Virginia: 21 YRS.

Years Company has been an authorized dealer for proposed unit: 1/2 year YRS.

X4.2 DELIVERY:

X4.2.1 Delivery date of completed representative unit: 120 Calendar Days After Date of Purchase Agreement

X4.2.2 Delivery date of balance of completed units: 150-180 Calendar Days After Date of Purchase Agreement

X5.0 AWARD CRITERIA;

X5.1	Prices in quantities of	1-10	<u>          \$96,322.00</u> per unit
		11-20	<u>          \$96,322.00</u> per unit
		21 and over	<u>          \$96,322.00</u> per unit

X6.0 SPECIFICATIONS - GENERAL

X6.1 Manufacturer, model, series, and date of manufacture of proposed unit:

Dressta TD-7M

Is descriptive literature, fully describing proposed unit attached to your bid?  YES  NO

If not, why? \_\_\_\_\_

X6.2 Will the required number of service manuals, and complete parts list be delivered to the Equipment Division at Buckhannon upon completion of delivery of total units?  YES  NO

Will the required Equipment Preventive Maintenance Form (Section X6.2 of Bidders Evaluation Report) be provided upon inspection of the pilot unit?  YES  NO

X62  
2-10-00

EQUIPMENT PREVENTATIVE MAINTENANCE QUESTIONNAIRE

THIS FORM MUST BE COMPLETED IN ITS ENTIRETY BY SUCCESSFUL BIDDER OR MANUFACTURER'S TECHNICAL REPRESENTATIVE PRIOR TO DELIVERY OF PILOT MODEL TO THE WVDOT.

DESCRIPTION: \_\_\_\_\_ MAKE: \_\_\_\_\_

MODEL: \_\_\_\_\_ YEAR: \_\_\_\_\_ PURCHASE AMOUNT: \_\_\_\_\_

ENGINE: MAKE: \_\_\_\_\_ MODEL: \_\_\_\_\_ FUEL TYPE: \_\_\_\_\_

HORSEPOWER: \_\_\_\_\_ CYLINDER: \_\_\_\_\_ ENGINE SERIAL: \_\_\_\_\_

COOLING SYSTEM CAPACITY: \_\_\_\_\_

BELTS: DESCRIPTION: \_\_\_\_\_ PART NUMBERS: \_\_\_\_\_

\_\_\_\_\_

\_\_\_\_\_

GVW: \_\_\_\_\_ AXLE CAPACITY: FRONT: \_\_\_\_\_ REAR: \_\_\_\_\_

TIRES: FRONT MAKE & SIZE: \_\_\_\_\_

REAR MAKE & SIZE: \_\_\_\_\_

DIMENSIONS OF UNIT: LENGTH: \_\_\_\_\_ WIDTH: \_\_\_\_\_ LENGTH: \_\_\_\_\_

VENDOR CONTACT PERSON: \_\_\_\_\_ PHONE: \_\_\_\_\_

PARTS:

BATTERY MAKE: \_\_\_\_\_ MODEL: \_\_\_\_\_ CCA: \_\_\_\_\_

TOP OR SIDE POST: \_\_\_\_\_ DIMENSIONS: LENGTH \_\_\_\_\_ WIDTH \_\_\_\_\_ HEIGHT \_\_\_\_\_

SPARK PLUGS OR FUEL INJECTORS MAKE: \_\_\_\_\_ PART # \_\_\_\_\_

FUEL PUMP OR INJECTION PUMP MAKE: \_\_\_\_\_ MODEL: \_\_\_\_\_

ALTERNATOR MAKE: \_\_\_\_\_ PART #: \_\_\_\_\_

STARTER MAKE: \_\_\_\_\_ PART #: \_\_\_\_\_

TURBO CHARGER MAKE: \_\_\_\_\_ PART #: \_\_\_\_\_

TRANS. MAKE: \_\_\_\_\_ MODEL: \_\_\_\_\_ AUTO/MANUAL: \_\_\_\_\_

HYDRAULIC PUMP MAKE: \_\_\_\_\_ MODEL: \_\_\_\_\_

FILTERS MAKE PART NO LUBRICANT MANUFACTURER TYPE

OIL \_\_\_\_\_ ENGINE \_\_\_\_\_

AIR INNER \_\_\_\_\_ TRANSMISSION \_\_\_\_\_

AIR OUTER \_\_\_\_\_ POWER STEERING \_\_\_\_\_

FUEL PRIMARY \_\_\_\_\_ HYDRAULIC \_\_\_\_\_

FUEL SECONDARY \_\_\_\_\_ DIFFERENTIALS \_\_\_\_\_

COOLANT \_\_\_\_\_ BRAKE FLUID \_\_\_\_\_

HYDRAULIC \_\_\_\_\_ COOLANT \_\_\_\_\_

OTHER \_\_\_\_\_ OTHER \_\_\_\_\_

X6.3 TRAINING:

Will training seminar be conducted on Preventive Maintenance, Operator and Mechanic Training  YES  NO

Will you conduct training with each purchase order against this open end contract?  YES  NO

Will training be conducted within 2 working days from the delivery of the pilot unit on the individual purchase order?  YES  NO

If NO, explain time frame \_\_\_\_\_

Will an Operator's Manual be furnished to the Training Academy?  YES  NO

X6.4 If you are the successful vendor, will you furnish all training aids, i.e., videos, projectors, required in conducting the training?  YES  NO

X6.4.1 Will all manuals, booklets, etc. explaining preventive maintenance, operator procedures, and service schedule be delivered with each unit?  YES  NO  
If NO, explain \_\_\_\_\_

X6.5 WARRANTY AND SERVICE POLICY

Will the warranty and service you provide comply with all areas as stated in Section 6.5 of specifications  YES  NO

Is warranty literature attached?  YES  NO

Is a minimum two (2) year bumper to bumper basic warranty included?  YES  NO  
Describe:

All components except maintenance items (ie - fuel, oil, \_\_\_\_\_  
filters and lubricants)

Extended service contract coverage with costs and all associated information:  
\_\_\_\_\_  
\_\_\_\_\_  
\_\_\_\_\_  
\_\_\_\_\_  
\_\_\_\_\_

X6.5 WARRANTY AND SERVICE POLICY QUESTIONNAIRE

THIS FORM MUST BE COMPLETED IN ITS ENTIRETY BY THE SUCCESSFUL BIDDER OR MANUFACTURERS TECHNICAL REPRESENTATIVE PRIOR TO DELIVERY OF PILOT MODEL TO THE WVDOH (If additional lines are needed, make copies of form.)

1. Define the terms of the standard warranty. If not offered, so state. (Attach copy)  
 12 months - unlimited hours

2. Define warranty service to be performed at DOH facilities and warranty service to be performed at manufacturer's representative facility. List name and location of manufacturer's representative.  
 All warranty work to be performed at Dealer facility unless it is a machine down emergency.  
 Brian Cantrell - Fairmont, WV

3. List locations for parts inventories that are within the State of West Virginia. Also, list availability levels, if known.  
 Fairmont, WV  
 Charleston, WV

4. During the term of warranty, list the guarantee discount to manufacturer's published list price for parts that bidder will sell the parts to owner.

A.	Terms: Net 30	Manufacturer's published list price less:	<u>0</u>	% discount
B.	Terms: Net 60	Manufacturer's published list price less:	<u>0</u>	% discount
C.	Terms: Net 90	Manufacturer's published list price less:	<u>0</u>	% discount

5. During the term of warranty, will all manufacturers or engineering improvements be submitted to Division of Highways?  X  YES   NO

6. During the term of warranty, list the guaranteed rates charged for repair to the unit.

A.	Shop Rate	\$ <u>n/a</u> per mechanic hour
B.	Travel Time Charge (Specify if one-way)	\$ <u>n/a</u> per mechanic hour <u>n/a</u> ; port to port <u>n/a</u>
C.	Mileage Charge (Specify if one-way)	\$ <u>n/a</u> per vehicle mile <u>n/a</u> ; port to port <u>n/a</u>
D.	Field Mechanic Rate	\$ <u>n/a</u> per mechanic hour
E.	Specify period of time that prices are in effect:	<u>until warranty expires</u>
F.	Surcharge for miscellaneous items:	<u>n/a</u> %

## X6.6 EVALUATION COMMITTEE REQUIREMENTS

Is all component specifications, product literature, component models provided for Evaluation Committee bid determination?  YES  NO

X6.7 Will all parts, equipment, accessories, material, design and performance characteristics not specified herein, but which are necessary to provide a complete unit, be furnished with the unit and conform in strength, quality of material, and quality of workmanship to those which are advertised and provided to the market in general by the unit industry?  YES  NO

X6.7.1 Are all parts and accessories adequate and regularly supplied as standard to be included except those which may be duplications of specifications herein, and except these by specification are not to be furnished?  YES  NO

X6.7.2 Are all standard safety features that are required by Federal and State statutes of law included?  YES  NO

## X7.0 SPECIFICATIONS OF THE QUOTED UNIT

The bidder should complete the following schedule in order for the Division to compare the actual bid unit to the specifications. Should the bidder except a requirement, then such exception may be only on the basis that such feature is not offered by the manufacturer. The Division will have the sole discretion as to whether the bidder's substitution meets the requirements of the specifications.

Manufacturer: Dressta Model: TD-7M

## X7.1 Engine:

X7.1.1 Is engine diesel  YES  NO

X7.1.2 Engine horsepower: 80

X7.1.3 Engine flywheel power: 74 HP

## X7.2 Weight:

X7.2.1 Operating weight: 16,200 lbs.

## X7.3 Transmission:

X7.3.1 Travel speed forward: 5.7 MPH/ 9.2 KM/h

X7.3.2 Travel speed reverse: 6.7 MPH/ 10.8 KM/h

## X7.4 Cab/ROPS/FOPS:

XD7.4.1 Does unit have fully enclosed cab with air conditioning, ROPS, FOPS, and rear screen  YES  NO

X7.4.1.1 Does ROPS meet SAE J397-Oct. 95, SAFJ1040 May 94, ISO3471-94 ISO 3164-95 Standards  YES  NO





State of West Virginia  
 Department of Administration  
 Purchasing Division  
 2019 Washington Street East  
 Post Office Box 50130  
 Charleston, WV 25305-0130

**Request for  
 Quotation**

RFQ NUMBER
707EC016

PAGE
1

ADDRESS CORRESPONDENCE TO ATTENTION OF
JOHN JOHNSTON 304-558-2402

RFQ COPY

TYPE NAME/ADDRESS HERE

Anderson Equipment Company  
 P. O. Box 3109  
 Charleston, WV 25331

DIVISION OF HIGHWAYS  
 EQUIPMENT DIVISION

ROUTE 33  
 BRUSHY FORK ROAD  
 BUCKHANNON, WV

26201

304-472-1750

DATE PRINTED	TERMS OF SALE	SHIP VIA	F.O.B.	FREIGHT TERMS
02/15/2007				
BID OPENING DATE: 02/28/2007		BID OPENING TIME 01:30PM		

LINE	QUANTITY	UOP	CAT NO	ITEM NUMBER	UNIT PRICE	AMOUNT
				ADDENDUM NO. 1		
				CHANGES TO THE SPECIFICATIONS PER THE ATTACHED		
				BID OPENING DATE AND TIME REMAINS THE SAME.		
				NO OTHER CHANGES.		
0001	1	EA		020-68		
				75 HORSEPOWER TRACTOR/DOZER WITH WINCH AND BLADE		
***** THIS IS THE END OF RFQ 707EC016 ***** TOTAL:						

SEE REVERSE SIDE FOR TERMS AND CONDITIONS

SIGNATURE	TELEPHONE	DATE
TITLE	FEIN	ADDRESS CHANGES TO BE NOTED ABOVE

WHEN RESPONDING TO RFQ, INSERT NAME AND ADDRESS IN SPACE ABOVE LABELED 'VENDOR'

*ym 2/15/07*



**GENERAL TERMS & CONDITIONS  
REQUEST FOR QUOTATION (RFQ) AND REQUEST FOR PROPOSAL (RFP)**

1. Awards will be made in the best interest of the State of West Virginia.
2. The State may accept or reject in part, or in whole, any bid.
3. All quotations are governed by the *West Virginia Code* and the *Legislative Rules* of the Purchasing Division.
4. Prior to any award, the apparent successful vendor must be properly registered with the Purchasing Division and have paid the required \$125.00 registration fee.
5. All services performed or goods delivered under State Purchase Orders/Contracts are to be continued for the term of the Purchase Order/Contract, contingent upon funds being appropriated by the Legislature or otherwise being made available. In the event funds are not appropriated or otherwise available for these services or goods, this Purchase Order/Contract becomes void and of no effect after June 30.
6. Payment may only be made after the delivery and acceptance of goods or services.
7. Interest may be paid for late payment in accordance with the *West Virginia Code*.
8. Vendor preference will be granted upon written request in accordance with the *West Virginia Code*.
9. The State of West Virginia is exempt from federal and state taxes and will not pay or reimburse such taxes.
10. The Director of Purchasing may cancel any Purchase Order/Contract upon 30 days written notice to the seller.
11. The laws of the State of West Virginia and the *Legislative Rules* of the Purchasing Division shall govern all rights and duties under the Contract, including without limitation the validity of this Purchase Order/Contract.
12. Any reference to automatic renewal is hereby deleted. The Contract may be renewed only upon mutual written agreement of the parties.
13. **BANKRUPTCY:** In the event the vendor/contractor files for bankruptcy protection, this contract is automatically null and void, and is terminated without further order.
14. **HIPAA Business Associate Addendum -** The West Virginia State Government HIPAA Business Associate Addendum (BAA), approved by the Attorney General, and available online at the Purchasing Division's web site (<http://www.state.wv.us/admin/purchase/vrc/hipaa.htm>) is hereby made part of the agreement. Provided that, the Agency meets the definition of a Covered Entity (45 CFR §160.103) and will be disclosing Protected Health Information (45 CFR §160.103) to the vendor.

---

**INSTRUCTIONS TO BIDDERS**

1. Use the quotation forms provided by the Purchasing Division.
2. **SPECIFICATIONS:** Items offered must be in compliance with the specifications. Any deviation from the specifications must be clearly indicated by the bidder. Alternates offered by the bidder as **EQUAL** to the specifications must be clearly defined. A bidder offering an alternate should attach complete specifications and literature to the bid. The Purchasing Division may waive minor deviations to specifications.
3. Complete all sections of the quotation form.
4. Unit prices shall prevail in cases of discrepancy.
5. All quotations are considered F.O.B. destination unless alternate shipping terms are clearly identified in the quotation.
6. **BID SUBMISSION:** All quotations must be delivered by the bidder to the office listed below prior to the date and time of the bid opening. Failure of the bidder to deliver the quotations on time will result in bid disqualifications.

**SIGNED BID TO:**

Department of Administration  
Purchasing Division  
2019 Washington Street East  
Post Office Box 50130  
Charleston, WV 25305-0130

ADDENDUM #1  
707EC016

OPEN END CONTRACT

75 HORSEPOWER TRACTOR/DOZER WITH WINCH AND BLADE

CHANGES TO SPECIFICATIONS:

4.2 DELIVERY (3<sup>RD</sup> PARAGRAPH)

FROM:

A completed pilot model for inspection must be provided within 60 calendar days after the date of the purchase agreement by the successful vendor.

TO:

A completed pilot model for inspection should be provided within 120 calendar days after the date of the purchase agreement by the successful vendor.

6.3 TRAINING (2<sup>ND</sup> PARAGRAPH)

FROM:

Manufacturers and/or dealers shall be required to furnish the Training Academy with one (1) Operator's Manual

TO:

Manufacturers and/or dealers shall be required to furnish the Training Academy with one (1) Operator's Manual to be shipped direct to Letha Lamb, WVDOH Training Academy, Post Office Box 610, Buckhannon, West Virginia 26201 prior to delivery of the pilot

6.5 WARRANTY AND SERVICE POLICY (2<sup>ND</sup> PARAGRAPH)

FROM:

A mandatory minimum two (2) year bumper to bumper basic warranty is required for this unit.

TO:

A mandatory minimum two (2) year bumper to bumper basic warranty including parts and labor is required for this unit.

7.2.1 FROM:

Operating weight shall be minimum 15,000 lbs. to maximum 19,000 lbs.

TO:

Operating weight shall be minimum 15,000 lbs. to maximum 21,000 lbs.

ADDENDUM #1  
707EC016

## OPEN END CONTRACT

## 75 HORSEPOWER TRACTOR/DOZER WITH WINCH AND BLADE

## CHANGES TO BIDDER'S EVALUATION REPORT:

## X4.2 DELIVERY

X4.2.1 NO CHANGE REQUIRED

Delivery date of completed representative unit: 120 calendar days after date of purchase agreementX6.3 TRAINING (5<sup>TH</sup> QUESTION)

## FROM:

Will an Operator's Manual be furnished to the Training Academy?  YES  NO

## TO:

Will an Operator's Manual be furnished directly to Letha Lamb Training Academy prior to the delivery of the pilot?  YES  NOX6.5 WARRANTY AND SERVICE POLICY (3<sup>RD</sup> QUESTION)

## FROM:

Is a minimum two (2) year bumper to bumper basic warranty included?  YES  NO

## TO:

Is a minimum two (2) year bumper to bumper parts and labor basic warranty included with the unit?  YES  NO

## X7.2.1 NO CHANGE REQUIRED

Operating weight: 16,200 lbs

## SIGN IN SHEET

RFQ # TOTECO16Date: 2-14-07

Firm & Representative Name:	Mailing Address:	Phone, Fax, & E-Mail:
1. <u>Walker Machinery</u> <u>Eric Ranney</u>	<u>PO Box 2427</u> <u>Charleston WV 25329</u>	P <u>304-389-4190</u> F <u>304-759-6404</u> E-mail <u>eranney@walker-co</u>
2. <u>WEST VIRGINIA TRACTOR</u> <u>GARY GRADY</u>	<u>P.O. Box 473</u> <u>CHARLESTON WV 25322</u>	P <u>346-5301</u> F <u>346-5305</u> E-mail <u>wvtractor@msn.com</u>
3. <u>Reckard Equipment Co</u> <u>Robert Shelton</u>	<u>P.O. Box 273</u> <u>Beersville W.V.</u>	P <u>872-4055</u> F <u>872-7288</u> E-mail <u>Nebo@Reckard.com</u>
4. <u>State Equipment, Inc.</u> <u>Alan Poxel</u>	<u>500 Goff Mtn. Rd</u> <u>Cross Lanes WV</u>	P <u>776-4405</u> F <u>776-4409</u> E-mail <u>calan@stateequipment.com</u>
5. <u>State Equipment</u> <u>Jason Lamm</u>	<u>560 New Goff Mtn Rd</u> <u>Cross Lanes</u>	P <u>304 776 4405</u> F <u>4409</u> E-mail <u>JasonL@stateequipment.com</u>

Please print or write legibly!

Your fax # is essential to contact you timely!

W

**SIGN IN SHEET**

RFQ # \_\_\_\_\_

Date: \_\_\_\_\_

Firm & Representative Name:

Mailing Address:

Phone, Fax, & E-Mail:

- 1 ANDERSON EQUIP CO. Box 3109 P. 304-756-2800  
Mike Bunker + Terry Charleston, WV 25331 304-756-2799  
SURFACE F +surface@andersonwv.com  
E-mail +surface@andersonwv.com
- 2 DRESSITA N.A 1327 BARCLAY BLVD P. 847-537-4388  
PAUL BROWN PUFFALO GROVE, IL F 847-537-2873  
E-mail P. BROWN@DRESSITAN.COM
- 3 Anderson Equip. Co. P.O. Box 3109 P. (304) 756-2800  
Terri Surface Chas., WV 25381 F. (304) 756-2799  
E-mail \_\_\_\_\_
- 4 RISH EQUIPMENT CO. P.O. 906 (1001 Bridgeport Gap) P. 304-842-3511  
Antonio D. Selario Bridgeport, WV 26330 F. 304-842-6126  
E-mail a.selario@rish.com
- 5 RISH EQUIPMENT CO PO Box 906 P. 304-842-3511  
Paul Calvert Bridgeport WV 26330 F. 304-842-6126  
E-mail pcalvert@rsh.com

Please print or write legibly!

Your fax # is essential to contact you timely!

**PURCHASING CONTINUATION SHEET**

Buyer: JJ-33	Page 6	Req. or P.O. No.: 707EC016
Spending Unit:		

Vendor

Requisition No.: 707EC016

**ADDENDUM ACKNOWLEDGEMENT**

I hereby acknowledge receipt of the following checked addendum(s) and have made the necessary revisions to my proposal, plans and/or specifications, etc..

Addendum No.'s:

- No. 1 ✓
- No. 2 \_\_\_\_\_
- No. 3 \_\_\_\_\_
- No. 4 \_\_\_\_\_
- No. 5 \_\_\_\_\_

I understand that failure to confirm the receipt of the addendum(s) may be cause for rejection of bids.

Michael R. Beuke / tls  
Signature

Anderson Equipment Company  
Company

February 28, 2007  
Date

 **DRESSTA**®

**TD-7M**  
CRAWLER DOZER  
STD-LT-LGP



**Net Horsepower**  
74 hp (55 kW)

**Blade Capacity**  
1.81 yd<sup>3</sup> and 1.90 yd<sup>3</sup>  
(1.40 m<sup>3</sup> and 1.45 m<sup>3</sup>)

**Operating Weight**  
16,200 lb (7348 kg) STD  
16,970 lb (7697 kg) LT  
17,630 lb (7997 kg) LGP

# TD-7M

## STD-LT-LGP

- Full power shift transmission
- Highly efficient torque converter
- Wet type steering clutches and brakes

- Lubricated track system
- Hydraulic lift, tilt & angle blade
- Left joystick for transmission and steering control

### ENGINE

* Make and model	CUMMINS B4.5
Type	4-cycle diesel, naturally aspirated, direct start direct injection
** Gross Horsepower @ 2500 rpm	80 hp (60 kW)
*** Net Flywheel power @ 2500 rpm	74 hp (55 kW)
Maximum torque @ 1300 rpm	222 ft lb (301 Nm)
Number of cylinders	4
Displacement	275 in <sup>3</sup> (4.5 l)
Bore and stroke	4.02" x 5.42" (102 x 137.7 mm)
Lubrication, full flow filtering	full pressure
Number of main bearings	5
Electrical system	12 V
Air cleaner	two stage dry type with service indicator

\* Meets EPA emission regulations for Tier 2

\*\* Output of complete engine operating under SAE J1995 conditions

\*\*\* Flywheel power-output of standard engine complete with fan, air cleaner, alternator (not charging) water pump, lubricating oil pump and fuel pump, per SAE J1349

### TRANSMISSION & TORQUE CONVERTER

Modular countershaft type full power shift, electro-hydraulically actuated with 3 speeds forward, 3 reverse. Joystick control valve has electric transmission range shift control for up and down shifting. Single stage 11" (280 mm) torque converter with 2.16:1 stall ratio drives to transmission through a permanently lubricated double universal joint.

### TRAVEL SPEEDS

Gear	Forward		Reverse	
	mph	(km/h)	mph	(km/h)
1 st	2.1	(3.4)	2.5	(4.0)
2 nd	3.5	(5.6)	4.1	(6.6)
3 rd	5.7	(9.2)	6.7	(10.8)

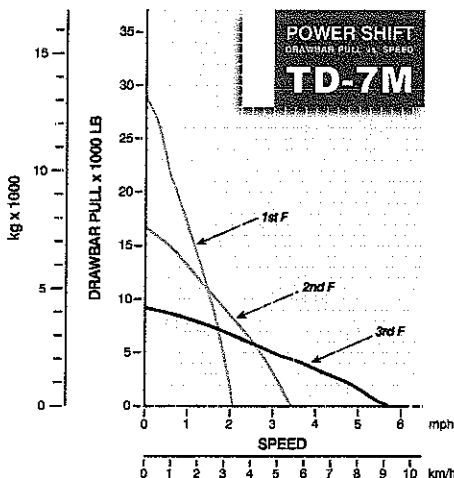

### STEERING & BRAKING

Single stage planetary type, wet single disc steering clutches. Single disc wet-type steering brakes. Steering clutches and brakes run in oil and are hydraulically actuated. Right foot pedal applies decelerator, center pedal applies disc brakes for downhill speed control and parking. Brakes are spring applied and hydraulically released. Parking brake is also applied by safety lever.

### FINAL DRIVES

Single stage spur-gear drive to sprockets 5.66:1 reduction ratio. Final drive has metal face seals. Operates in oil for long life. Sprockets are replaceable without removing track frames.

### TRACK FRAME

Heavy steel channel rigid mount.

	STD	LT	LGP
Track rollers, each side	5	6	6
Top idlers, each side	1	1	1
Front idlers (disc type)		casting	
All rollers and idlers		lifespan lubricated	

### TRACKS

	STD	LT	LGP
Track shoe width	15" (381 mm)	15" (381 mm)	24" (610 mm)
Track shoes, each side	34	37	37
Ground contact area	2.160 in <sup>2</sup> (1.4 m <sup>2</sup> )	2.460 in <sup>2</sup> (1.59 m <sup>2</sup> )	3.936 in <sup>2</sup> (2.54 m <sup>2</sup> )
Ground pressure	7.45 psi (51 kPa)	6.86 psi (47 kPa)	4.45 psi (31 kPa)
Strutted track link pitch		.. 6.5" (165 mm)	
Height of grouser		2.11" (53.6 mm)	
Track adjustment		full hydraulic	
Minimum ground clearance from bottom face of shoe		12.7" (323 mm)	
Recovery hitch-height from ground to centerline of clevis		18.8" (477 mm)	

### REFILL CAPACITIES

	US gal	(Liter)
Fuel tank	45	(170)
Cooling system	6.6	(24.9)
Crankcase	2.7	(10.4)
Transmission & steering drive	18.5	(70)
Final drive each side	2.5	(9.5)

### WEIGHTS (Operating)

Includes ROPS, hydraulic angle blade standard equipment and full fuel.		
STD	16 200 lb	(7348 kg)
LT	16 970 lb	(7697 kg)
LGP	17 630 lb	(7997 kg)



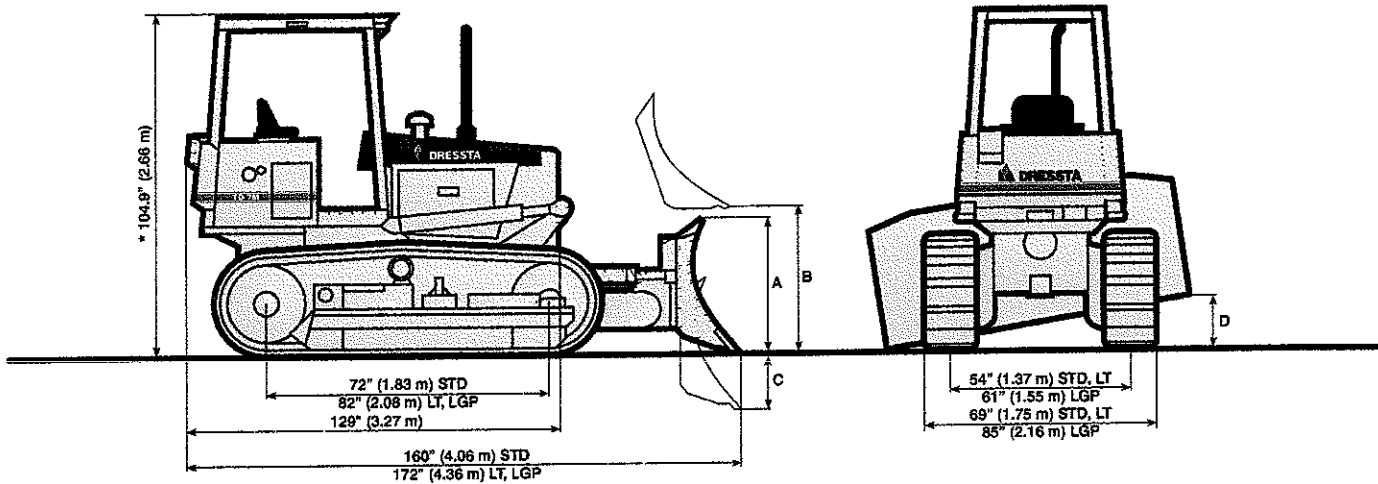

\* Overall height with Cab ROPS - 106.2" (2.70 m)  
 Vertical dimensions include 2 11" (53.6 mm) grouser height

### OVERALL DIMENSIONS WITH EQUIPMENT

Type of Track Frame	STD	LT	LGP
Length with blade and ripper	14'9" (4.50 m)	15'8" (4.78 m)	15'8" (4.78 m)
Width, blade angled	7'10" (2.39 m)	7'10" (2.39 m)	8'5" (2.57 m)
Width, blade straight	8'7" (2.62 m)	8'7" (2.62 m)	9'3" (2.82 m)

### BLADE SPECIFICATIONS

Type of Track Frame	STD	LT	LGP
Blade capacity, SAE J1265	1.81 yd <sup>3</sup> (1.4 m <sup>3</sup> )	1.81 yd <sup>3</sup> (1.4 m <sup>3</sup> )	1.90 yd <sup>3</sup> (1.45 m <sup>3</sup> )
Max. usable track shoe width	17" (432 mm)	17" (432 mm)	24" (610 mm)
Blade dimensions:			
- width over end bits	8'7" (2.62 m)	8'7" (2.62 m)	9'3" (2.82 m)
- height, struts centered	A	A	A
Max. lift, straight	B	B	B
Max. drop below ground level	C	C	C
Max. tilt adjustment	D	D	D
Blade angle, either side	25°	25°	25°

### RIPPER SPECIFICATION

Type	Multi-Shank	Shank
Tool Beam		
Overall width	4'7" (1.40 m)	Number of shanks per ripper, max
Cross section, height x width	6'0" x 6'0" (152 x 152 mm)	Spacing center to center
Ground clearance under tool beam	27'4" (696 mm)	Penetration, max
Weight		Ground clearance, max. raised
Complete, including three shanks	950 lb (430 kg)	Shank positions (vertical)
Each additional shank	20 lb (9 kg)	

### HYDRAULIC CONTROL SYSTEM

Pump, tandem gear		Cylinders, bore and stroke	
Output @ 500 psi (3.45 MPa)		Lift (2)	3'5" x 17'7" (89 x 449 mm)
& rated engine rpm	19.9 gpm (75.2 l/min)	Angle (2)	3'0" x 13'9" (76 x 352 mm)
Relief valve setting		Tilt (1)	3'5" x 5'7" (89 x 144 mm)
Blade lift & ripper	2,250 psi (15 512 kPa)	Reservoir with sight gauge, system capacity, right fender mounted,	
Tilt	2,250 psi (15 512 kPa)	includes cylinders & lines	13.5 gal (51 l)

# TD-7M

## CRAWLER DOZER

### STD-LT-LGP

#### STANDARD EQUIPMENT

- |  |  |
|--|--|
| <ul style="list-style-type: none"> <li>• Air cleaner, dry type, with primary and safety elements and service indicator</li> <li>• Alarm, back-up, 2 level sound</li> <li>• Alternator, 65 A</li> <li>• Antifreeze, -34°F (-37°C)</li> <li>• Battery, (1) 12 V, 815 CCA, maintenance free</li> <li>• Canopy ROPS (SAE J1040) with roof extension, roof headliner, mirror</li> <li>• Cooling module; includes radiator and transmission oil cooler (side-by-side); isolation mounted</li> <li>• Cup holder</li> <li>• Decelerator – right pedal and brake – center pedal with safety lock foot operated</li> <li>• Engine hood, solid</li> <li>• Engine side doors perforated</li> <li>• Fan, blower</li> <li>• Filters with "spin-on" elements: engine oil, fuel, power train, equipment hydraulic</li> <li>• Guards: crankcase with pull hook, instrument panel, lights, radiator, transmission, rock deflector, fan fuel tank bottom and back-up alarm</li> <li>• Hitch, retrieval</li> <li>• Horn</li> <li>• Hydraulics, 3-spool valve "T" control</li> <li>• Instruments:<br/>Gauges: hourmeter, coolant temperature, engine oil pressure power train oil temperature, voltmeter, fuel</li> </ul> | <ul style="list-style-type: none"> <li>Warning lights: transmission filter service indicator, air filter and hydraulic filter service indicator</li> <li>• Lights, 2 front, 1 rear, halogen type</li> <li>• Muffler, underhood with exhaust pipe and elbow</li> <li>• Power train diagnostic check panel w/brake release port</li> <li>• Protection guard for fuel tank and filler</li> <li>• Radiator guard door, louvered</li> <li>• Seat belt (SAE J386) – 3 inch retractable</li> <li>• Seat, suspension type with adjustable arm rests</li> <li>• Starting, 12 V</li> <li>• Steering &amp; transmission left hand single lever control, joystick w/safety lever</li> <li>• Strainer, fuel</li> <li>• Throttle control, L.H location</li> <li>• Tools compartment</li> <li>• Torque converter, single stage</li> <li>• Track adjusters, hydraulic</li> <li>• Track chains, sealed &amp; lubricated (LTS) with split master links, 34 links</li> <li>• Track frame, 5 rollers, 54" (1.37 m) gauge, rigid type lifespan lubricated rollers and idlers, front and rear chain guides</li> <li>• Track frame covers</li> <li>• Track shoes, 15" (381 mm)</li> <li>• Transmission, full power shift 3 speeds forward, 3 reverse</li> <li>• Water separator, fuel system</li> </ul> |
|--|--|

#### OPTIONAL ATTACHMENTS

- |   |  |
|---|--|
| <ul style="list-style-type: none"> <li>• Air conditioner/heater/pressurizer/defroster</li> <li>• Angle dozer 1.81 cu.yd (1.40 cu.m), inside arm w/hyd. tilt &amp; angle, for STD</li> <li>• Angle dozer 1.81 cu.yd (1.40 cu.m), inside arm w/hyd. tilt &amp; angle, for LT</li> <li>• Angle dozer, wide, 1.90 cu.yd (1.45 cu.m), inside arm w/hyd. tilt &amp; angle for LGP</li> <li>• Battery, cold start, 12 V, 960 CCA</li> <li>• Counterweights, front idler</li> <li>• Cab, ROPS with sound suppression wipers (4) and washers, mirror, dome light &amp; tinted safety glass</li> <li>• Defroster fan for use with cab</li> <li>• Exhaust pipe, forestry for use w/sweeps</li> <li>• Fan, reversible</li> <li>• Guards <ul style="list-style-type: none"> <li>– track roller, standard strength</li> <li>– track roller, full length, heavy duty type</li> </ul> </li> <li>• Heater/pressurizer/defroster</li> <li>• Hood, perforated (blower fan recommended)</li> <li>• Hydraulics 4-spool valve w/2 levers ("T" + single), for use w/ripper or auxiliary attachments</li> <li>• Sealed track system, 34 links, for STD</li> <li>• Lubricated track system, 37 links for LT and LGP</li> <li>• Mirrors, 2 pcs, for use with cab</li> <li>• Resonator, exhaust</li> </ul> | <ul style="list-style-type: none"> <li>• Ripper, multi-shank w/3 teeth (provision for 5 teeth)</li> <li>• Screening package, black painted<br/>(Canopy ROPS for screens installation must be ordered) <ul style="list-style-type: none"> <li>– screens, front</li> <li>– doors and side screens w/third post</li> <li>– screen, overhead, for upper front lights protection</li> </ul> </li> <li>• Sweeps, front and screen, rear (required for screening pkg. installation)</li> <li>• Track frame for LT applications, 6 rollers, 54" (1.37 m) gauge, rigid type</li> <li>• Track frame for LGP applications, 6 rollers 61" (1.55 m) gauge, rigid type</li> <li>• Track frame covers, LT</li> <li>• Track frame covers, LGP</li> <li>• Track shoes, set of 68, for STD <ul style="list-style-type: none"> <li>– 15" (381 mm) w/mud relief</li> <li>– 17" (432 mm)</li> </ul> </li> <li>• Track shoes, set of 74, for LT <ul style="list-style-type: none"> <li>– 15" (381 mm)</li> <li>– 15" (361 mm) w/mud relief</li> <li>– 17" (432 mm)</li> </ul> </li> <li>• Track shoes, set of 74, for LGP <ul style="list-style-type: none"> <li>– 24" (610 mm)</li> <li>– 24" (610 mm), swamp type</li> </ul> </li> <li>• Vandalism protection</li> </ul> |
|---|--|

Specifications subject to change without notice. Illustrations may include optional attachments and accessories and may not include all standard equipment.  
NOTE: Dressta Low Ground Pressure (LGP) tractors are designed for use in mud, snow and other soft ground applications  
Use in hard or rocky conditions will reduce undercarriage life and can cause damage to components

### DRESSTA NORTH AMERICA, LTD.

1327 BARCLAY BLVD.  
BUFFALO GROVE, IL 60089  
phone (847) 537 4783 fax (847) 537 2873  
Toll free (877) DNA 2001  
[www.dresstanorthamerica.com](http://www.dresstanorthamerica.com)

AGREEMENT ADDENDUM

WV-96  
Rev 5/94

In the event of conflict between this addendum and the agreement this addendum shall control:

1. ARBITRATION - Any references to arbitration contained in the agreement are hereby deleted. Disputes arising out of the agreement shall be presented to the West Virginia Court of Claims
2. HOLD HARMLESS - Any clause requiring the Agency to indemnify or hold harmless any party is hereby deleted in its entirety
3. GOVERNING LAW - The agreement shall be governed by the laws of the State of West Virginia. This provision replaces any references to any other State's governing law.
4. TAXES - Provisions in the agreement requiring the Agency to pay taxes are deleted. As a State entity, the Agency is exempt from Federal, State, and local taxes and will not pay taxes for any Vendor including individuals, nor will the Agency file any tax returns or reports on behalf of Vendor or any other party.
5. PAYMENT - Any references to prepayment are deleted. Payment will be in arrears.
6. INTEREST - Should the agreement include a provision for interest on late payments, the Agency agrees to pay the maximum legal rate under West Virginia law. All other references to interest or late charges are deleted.
7. RECOUPMENT - Any language in the agreement waiving the Agency's right to set-off, counterclaim, recoupment, or other defense is hereby deleted.
8. FISCAL YEAR FUNDING - Service performed under the agreement may be continued in succeeding fiscal years for the term of the agreement contingent upon funds being appropriated by the Legislature or otherwise being available for this service. In the event funds are not appropriated or otherwise available for this service, the agreement shall terminate without penalty on June 30. After that date, the agreement becomes of no effect and is null and void. However, the Agency agrees to use its best efforts to have the amounts contemplated under the agreement included in its budget. Non-appropriation or non-funding shall not be considered an event of default.
9. STATUTE OF LIMITATION - Any clauses limiting the time in which the Agency may bring suit against the Vendor, lessor, individual, or any other party are deleted.
10. SIMILAR SERVICES - Any provisions limiting the Agency's right to obtain similar services or equipment in the event of default or non-funding during the term of the agreement are hereby deleted.
11. ATTORNEY FEES - The Agency recognizes an obligation to pay attorney's fees or costs only when assessed by a court of competent jurisdiction. Any other provision is invalid and considered null and void.
12. ASSIGNMENT - Notwithstanding any clause to the contrary, the Agency reserves the right to assign the agreement to another State of West Virginia agency, board, or commission upon thirty (30) days written notice to the Vendor and Vendor shall obtain the written consent of Agency prior to assigning the agreement.
13. LIMITATION OF LIABILITY - The Agency, as a State entity, cannot agree to assume the potential liability of a Vendor. Accordingly, any provision limiting the Vendor's liability for direct damages or limiting the Vendor's liability under a warranty to a certain dollar amount or to the amount of the agreement is hereby deleted. In addition, any limitation is null and void to the extent that it precludes any action for injury to persons or for damages to personal property.
14. RIGHT TO TERMINATE - Agency shall have the right to terminate the agreement upon thirty (30) days written notice to Vendor.
15. TERMINATION CHARGES - Any provision requiring the Agency to pay a fixed amount or liquidated damages upon termination of the agreement is hereby deleted. The Agency may only agree to reimburse a Vendor for actual costs incurred or losses sustained during the current fiscal year due to wrongful termination by the Agency prior to the end of any current agreement term.
16. RENEWAL - Any reference to automatic renewal is hereby deleted. The agreement may be renewed only upon mutual written agreement of the parties.
17. INSURANCE - Any provision requiring the Agency to insure equipment or property of any kind and name the Vendor as beneficiary or as an additional insured is hereby deleted.
18. RIGHT TO NOTICE - Any provision for repossession of equipment without notice is hereby deleted. However, the Agency does recognize a right of repossession with notice.
19. ACCELERATION - Any reference to acceleration of payments in the event of default or non-funding is hereby deleted.
20. AMENDMENTS - All amendments, modifications, alterations, or changes to the agreement shall be in writing and signed by both parties. No amendment, modification, alteration, or change may be made to this addendum without the express written approval of the Purchasing Division and the Attorney General.

ACCEPTED BY:  
STATE OF WEST VIRGINIA

VENDOR

Spending Unit: \_\_\_\_\_

Company Name: Anderson Equipment Company

Signed: \_\_\_\_\_

Signed: Michael R. Benke /rls

Title: \_\_\_\_\_

Title: General Manager - WV

Date: \_\_\_\_\_

Date: February 28, 2007

# A F F I D A V I T

**West Virginia Code §5A-3-10a states:**

No contract or renewal of any contract may be awarded by the state or any of its political subdivisions to any vendor or prospective vendor when the vendor or prospective vendor or a related party to the vendor or prospective vendor is a debtor and the debt owned is an amount greater than one thousand dollars in the aggregate

**DEFINITIONS:**

"Debt" means any assessment, premium, penalty, fine, tax or other amount of money owed to the state or any of its political subdivisions because of a judgment, fine, permit violation, license assessment, defaulted workers' compensation premium, penalty or other assessment presently delinquent or due and required to be paid to the state or any of its political subdivisions, including any interest or additional penalties accrued thereon.

"Debtor" means any individual, corporation, partnership, association, limited liability company or any other form or business association owing a debt to the state or any of its political subdivisions. "Political subdivision" means any county commission; municipality; county board of education; any instrumentality established by a county or municipality; any separate corporation or instrumentality established by one or more counties or municipalities, as permitted by law; or any public body charged by law with the performance of a government function or whose jurisdiction is coextensive with one or more counties or municipalities. "Related party" means a party, whether an individual, corporation, partnership, association, limited liability company or any other form or business association or other entity whatsoever, related to any vendor by blood, marriage, ownership or contract through which the party has a relationship of ownership or other interest with the vendor so that the party will actually or by effect receive or control a portion of the benefit, profit or other consideration from performance of a vendor contract with the party receiving an amount that meets or exceeds five percent of the total contract amount.

**EXCEPTION:**

The prohibition of this section does not apply where a vendor has contested any tax administered pursuant to chapter eleven of this code, workers' compensation premium, permit fee or environmental fee or assessment and the matter has not become final or where the vendor has entered into a payment plan or agreement and the vendor is not in default of any of the provisions of such plan or agreement.

**LICENSING:**

Vendors must be licensed and in good standing in accordance with any and all state and local laws and requirements by any state or local agency of West Virginia, including, but not limited to, the West Virginia Secretary of State's Office, the West Virginia Tax Department, West Virginia Insurance Commission, or any other state agencies or political subdivision. Furthermore, the vendor must provide all necessary releases to obtain information to enable the Director or spending unit to verify that the vendor is licensed and in good standing with the above entities.

**CONFIDENTIALITY:**

The vendor agrees that he or she will not disclose to anyone, directly or indirectly, any such personally identifiable information or other confidential information gained from the agency, unless the individual who is the subject of the information consents to the disclosure in writing or the disclosure is made pursuant to the agency's policies, procedures and rules. Vendors should visit [www.state.wv.us/admin/purchase/privacy](http://www.state.wv.us/admin/purchase/privacy) for the Notice of Agency Confidentiality Policies.

Under penalty of law for false swearing (West Virginia Code, §61-5-3), it is hereby certified that the vendor acknowledges the information in this said affidavit and are in compliance with the requirements as stated.

Vendor's Name: Anderson Equipment Company

Authorized Signature: Michael K. Burke / MKB Date: February 28, 2007