



State of West Virginia  
 Department of Administration  
 Purchasing Division  
 2019 Washington Street East  
 Post Office Box 50130  
 Charleston, WV 25305-0130

# Request for Quotation

RFQ NUMBER:  
707EC012

PAGE:  
1

ADDRESS CORRESPONDENCE TO ATTENTION OF:  
JOHN JOHNSTON  
304-558-2402

RFQ COPY  
TYPE NAME/ADDRESS HERE

VENDOR

*Benson*

SHIP TO

DIVISION OF HIGHWAYS  
 EQUIPMENT DIVISION  
 ROUTE 33  
 BRUSHY FORK ROAD  
 BUCKHANNON, WV  
 26201 304-472-1750

DATE PRINTED	TERMS OF SALE	SHIP VIA	F.O.B	FREIGHT TERMS
11/21/2006	Net 30 Days	Benson	Buckhannon, WV	Included
BID OPENING DATE: 12/27/2006		BID OPENING TIME 01:30PM		

LINE	QUANTITY	UOP	CAT. NO.	ITEM NUMBER	UNIT PRICE	AMOUNT
0001	1	EA		070-66		\$25,395.00
<p>48 FOOT ALUMINUM PLATFORM TRAILER</p> <p>OPEN END CONTRACT</p> <p>TO PROVIDE 48 FOOT ALUMINUM PLATFORM TRAILER, AS DESCRIBED IN ATTACHED PROCUREMENT SPECIFICATION 251-1-K.</p> <p>THERE WILL BE A MANDATORY PRE-BID CONFERENCE AT THE STATE CAPITOL COMPLEX, BUILDING 15, CONFERENCE ROOM, AT 10:00 AM. ON 12/15/06. FAILURE TO ATTEND THE PRE-BID CONFERENCE WILL RESULT IN BID DISQUALIFICATION.</p> <p>QUESTIONS: WRITTEN QUESTIONS WILL BE ACCEPTED THROUGH CLOSE OF BUSINESS (5:00 PM EST) ON TUESDAY 12/05/06. SEND YOUR QUESTIONS TO: PURCHASING DIVISION ATTENTION JOHN JOHNSTON 2019 WASHINGTON ST. E. CHARLESTON, WV. 25305</p> <p>QUESTIONS MAY BE SENT VIA FAX, E-MAIL, OR REGULAR MAIL. E-MAIL: JJOHNSTON@WVADMIN.GOV FAX: 304-558-4115</p> <p>IT IS THE VENDORS RESPONSIBILITY TO VERIFY THAT THEIR QUESTIONS HAVE BEEN RECEIVED BY CALLING 304-558-2402.</p> <p>EXHIBIT 2</p> <p>LIFE OF CONTRACT: THIS CONTRACT BECOMES EFFECTIVE ON ..... AND EXTENDS FOR A PERIOD OF ONE (1) YEAR OR UNTIL SUCH "REASONABLE TIME" THEREAFTER AS IS</p>						

SEE REVERSE SIDE FOR TERMS AND CONDITIONS

SIGNATURE <i>Debbie Smith</i>	TELEPHONE (304)-489-9020	DATE 12/22/2006
TITLE Municipal Sales	FEIN 709042146	ADDRESS CHANGES TO BE NOTED ABOVE

WHEN RESPONDING TO RFQ, INSERT NAME AND ADDRESS IN SPACE ABOVE LABELED 'VENDOR'

**GENERAL TERMS & CONDITIONS  
REQUEST FOR QUOTATION (RFQ) AND REQUEST FOR PROPOSAL (RFP)**

1. Awards will be made in the best interest of the State of West Virginia.
2. The State may accept or reject in part, or in whole, any bid.
3. All quotations are governed by the *West Virginia Code* and the *Legislative Rules* of the Purchasing Division.
4. Prior to any award, the apparent successful vendor must be properly registered with the Purchasing Division and have paid the required \$125.00 registration fee.
5. All services performed or goods delivered under State Purchase Orders/Contracts are to be continued for the term of the Purchase Order/Contract, contingent upon funds being appropriated by the Legislature or otherwise being made available. In the event funds are not appropriated or otherwise available for these services or goods, this Purchase Order/Contract becomes void and of no effect after June 30.
6. Payment may only be made after the delivery and acceptance of goods or services.
7. Interest may be paid for late payment in accordance with the *West Virginia Code*.
8. Vendor preference will be granted upon written request in accordance with the *West Virginia Code*.
9. The State of West Virginia is exempt from federal and state taxes and will not pay or reimburse such taxes.
10. The Director of Purchasing may cancel any Purchase Order/Contract upon 30 days written notice to the seller.
11. The laws of the State of West Virginia and the *Legislative Rules* of the Purchasing Division shall govern all rights and duties under the Contract, including without limitation the validity of this Purchase Order/Contract.
12. Any reference to automatic renewal is hereby deleted. The Contract may be renewed only upon mutual written agreement of the parties.
13. **BANKRUPTCY:** In the event the vendor/contractor files for bankruptcy protection, this contract is automatically null and void, and is terminated without further order.
14. **HIPAA Business Associate Addendum** - The West Virginia State Government HIPAA Business Associate Addendum (BAA), approved by the Attorney General, and available online at the Purchasing Division's web site (<http://www.state.wv.us/admin/purchase/vrc/hipaa.htm>) is hereby made part of the agreement. Provided that, the Agency meets the definition of a Covered Entity (45 CFR §160.103) and will be disclosing Protected Health Information (45 CFR §160.103) to the vendor.

---

**INSTRUCTIONS TO BIDDERS**

1. Use the quotation forms provided by the Purchasing Division.
2. **SPECIFICATIONS:** Items offered must be in compliance with the specifications. Any deviation from the specifications must be clearly indicated by the bidder. Alternates offered by the bidder as **EQUAL** to the specifications must be clearly defined. A bidder offering an alternate should attach complete specifications and literature to the bid. The Purchasing Division may waive minor deviations to specifications.
3. Complete all sections of the quotation form.
4. Unit prices shall prevail in cases of discrepancy.
5. All quotations are considered F.O.B. destination unless alternate shipping terms are clearly identified in the quotation.
6. **BID SUBMISSION:** All quotations must be delivered by the bidder to the office listed below prior to the date and time of the bid opening. Failure of the bidder to deliver the quotations on time will result in bid disqualifications.

**SIGNED BID TO:**

Department of Administration  
Purchasing Division  
2019 Washington Street East  
Post Office Box 50130  
Charleston, WV 25305-0130



State of West Virginia  
 Department of Administration  
 Purchasing Division  
 2019 Washington Street East  
 Post Office Box 50130  
 Charleston, WV 25305-0130

# Request for Quotation

RFQ NUMBER  
**707EC012**

PAGE  
**2**

ADDRESS CORRESPONDENCE TO ATTENTION OF:  
**JOHN JOHNSTON**  
**304-558-2402**

RFQ COPY  
 TYPE NAME/ADDRESS HERE

VENDOR

SHIP TO

DIVISION OF HIGHWAYS  
 EQUIPMENT DIVISION  
 ROUTE 33  
 BRUSHY FORK ROAD  
 BUCKHANNON, WV  
 26201 304-472-1750

DATE PRINTED <b>11/21/2006</b>	TERMS OF SALE	SHIP VIA	F.O.B.	FREIGHT TERMS
-----------------------------------	---------------	----------	--------	---------------

BID OPENING DATE: **12/27/2006** BID OPENING TIME **01:30PM**

LINE	QUANTITY	UOP	CAT NO	ITEM NUMBER	UNIT PRICE	AMOUNT
<p>NECESSARY TO OBTAIN A NEW CONTRACT OR RENEW THE ORIGINAL CONTRACT. THE "REASONABLE TIME" PERIOD SHALL NOT EXCEED TWELVE (12) MONTHS. DURING THIS "REASONABLE TIME" THE VENDOR MAY TERMINATE THIS CONTRACT FOR ANY REASON UPON GIVING THE DIRECTOR OF PURCHASING THIRTY (30) DAYS WRITTEN NOTICE.</p> <p>UNLESS SPECIFIC PROVISIONS ARE STIPULATED IN THIS CONTRACT DOCUMENT, THE TERMS, CONDITIONS, AND PRICING SET HEREIN ARE FIRM FOR THE LIFE OF THE CONTRACT.</p> <p>RENEWAL: THIS CONTRACT MAY BE RENEWED UPON THE MUTUAL WRITTEN CONSENT OF THE SPENDING UNIT AND VENDOR, SUBMITTED TO THE DIRECTOR OF PURCHASING THIRTY (30) DAYS PRIOR TO THE EXPIRATION DATE. SUCH RENEWAL SHALL BE IN ACCORDANCE WITH THE TERMS AND CONDITIONS OF THE ORIGINAL CONTRACT AND SHALL BE LIMITED TO TWO (2) ONE (1) YEAR PERIODS.</p> <p>CANCELLATION: THE DIRECTOR OF PURCHASING RESERVES THE RIGHT TO CANCEL THIS CONTRACT IMMEDIATELY UPON WRITTEN NOTICE TO THE VENDOR IF THE COMMODITIES AND/OR SERVICES SUPPLIED ARE OF AN INFERIOR QUALITY OR DO NOT CONFORM WITH THE SPECIFICATIONS OF THE BID AND CONTRACT HEREIN</p> <p>OPEN MARKET CLAUSE: THE DIRECTOR OF PURCHASING MAY AUTHORIZE A SPENDING UNIT TO PURCHASE ON THE OPEN MARKET, WITHOUT THE FILING OF A REQUISITION OR COST ESTIMATE, ITEMS SPECIFIED ON THIS CONTRACT FOR IMMEDIATE DELIVERY IN EMERGENCIES DUE TO UNFORESEEN CAUSES (INCLUDING BUT NOT LIMITED TO DELAYS IN TRANSPORTATION OR AN UNANTICIPATED INCREASE IN THE VOLUME OF WORK).</p> <p>QUANTITIES: QUANTITIES LISTED IN THE REQUISITION ARE APPROXIMATIONS ONLY, BASED ON ESTIMATES SUPPLIES BY THE STATE SPENDING UNIT. IT IS UNDERSTOOD AND AGREED THAT</p>						

SEE REVERSE SIDE FOR TERMS AND CONDITIONS

SIGNATURE <i>Bella Smith</i>	TELEPHONE	DATE
TITLE	FEIN	ADDRESS CHANGES TO BE NOTED ABOVE

WHEN RESPONDING TO RFQ, INSERT NAME AND ADDRESS IN SPACE ABOVE LABELED 'VENDOR'



State of West Virginia  
 Department of Administration  
 Purchasing Division  
 2019 Washington Street East  
 Post Office Box 50130  
 Charleston, WV 25305-0130

# Request for Quotation

RFQ NUMBER  
**707EC012**

PAGE  
**3**

ADDRESS CORRESPONDENCE TO ATTENTION OF  
**JOHN JOHNSTON**  
**304-558-2402**

RFQ COPY  
 TYPE NAME/ADDRESS HERE

VENDOR

SHIP TO

DIVISION OF HIGHWAYS  
 EQUIPMENT DIVISION  
 ROUTE 33  
 BRUSHY FORK ROAD  
 BUCKHANNON, WV  
 26201 304-472-1750

DATE PRINTED	TERMS OF SALE	SHIP VIA	FOB	FREIGHT TERMS
11/21/2006				

BID OPENING DATE: **12/27/2006** BID OPENING TIME **01:30PM**

LINE	QUANTITY	UOP	CAT. NO.	ITEM NUMBER	UNIT PRICE	AMOUNT
<p>THE CONTRACT SHALL COVER THE QUANTITIES ACTUALLY ORDERED FOR DELIVERY DURING THE TERM OF CONTRACT, WHETHER MORE OR LESS THAN THE QUANTITIES SHOWN.</p> <p>ORDERING PROCEDURE: SPENDING UNIT(S) SHALL ISSUE A WRITTEN EQUIPMENT CONTRACT ORDER (FORM NUMBER WV-35) FOR COMMODITIES COVERED BY THIS CONTRACT. THE ORIGINAL WV-35 MUST BE SENT TO THE PURCHASING DIVISION OF THE DEPARTMENT OF ADMINISTRATION. AFTER APPROVAL AND ENCUMBRANCE, ONE COPY OF THE PURCHASE ORDER WILL BE RETURNED TO THE SPENDING UNIT AND ONE COPY FORWARDED TO THE VENDOR AS AUTHORIZATION FOR SHIPMENT. NO ORDER IS VALID UNLESS APPROVED AND ENCUMBERED BY THE PURCHASING DIVISION.</p> <p>BANKRUPTCY: IN THE EVENT THE VENDOR/CONTRACTOR FILES FOR BANKRUPTCY PROTECTION, THIS CONTRACT IS AUTOMATICALLY NULL AND VOID, AND IS TERMINATED WITHOUT FURTHER ORDER.</p> <p>REV. 9/98</p> <p>EXHIBIT 6</p> <p>PRICE ADJUSTMENT PROVISION:          THE STATE OF WEST VIRGINIA WILL CONSIDER BIDS THAT CONTAIN PROVISIONS FOR PRICE ADJUSTMENTS PRIOR TO THE ORIGINAL EXPIRATION OF THE CONTRACT, PROVIDED THAT SUCH PRICE ADJUSTMENT COVERS BOTH UPWARD AND DOWNWARD MOVEMENT OF THE COMMODITY PRICE, AND THAT ADJUSTMENT IS BASED ON THE "PASS THROUGH" INCREASE OR DECREASE OF RAW MATERIALS AND/OR LABOR, WHICH MAKE UP ALL OR A SUBSTANTIAL PART OF A PRODUCT. ADJUSTMENTS ARE TO BE BASED UPON AN ACTUAL DOLLAR FIGURE, NOT A PERCENTAGE. ALL PRICE ADJUSTMENT REQUESTS MUST BE SUBSTANTIATED IN</p>						

SEE REVERSE SIDE FOR TERMS AND CONDITIONS

SIGNATURE <i>Bubba Smith</i>	TELEPHONE	DATE
TITLE	FEIN	ADDRESS CHANGES TO BE NOTED ABOVE

WHEN RESPONDING TO RFQ, INSERT NAME AND ADDRESS IN SPACE ABOVE LABELED 'VENDOR'



State of West Virginia  
 Department of Administration  
 Purchasing Division  
 2019 Washington Street East  
 Post Office Box 50130  
 Charleston, WV 25305-0130

# Request for Quotation

RFQ NUMBER  
**707EC012**

PAGE  
**4**

ADDRESS CORRESPONDENCE TO ATTENTION OF  
**JOHN JOHNSTON  
 304-558-2402**

RFQ COPY  
 TYPE NAME/ADDRESS HERE

VENDOR

SHIP TO

DIVISION OF HIGHWAYS  
 EQUIPMENT DIVISION  
 ROUTE 33  
 BRUSHY FORK ROAD  
 BUCKHANNON, WV  
 26201 304-472-1750

DATE PRINTED	TERMS OF SALE	SHIP VIA	F.O.B.	FREIGHT TERMS
11/21/2006				

BID OPENING DATE: **12/27/2006** BID OPENING TIME **01:30PM**

LINE	QUANTITY	UQP	CAT. NO.	ITEM NUMBER	UNIT PRICE	AMOUNT
<p>A MANNER ACCEPTABLE TO THE DIRECTOR PURCHASING, E.G. GOVERNMENTAL BENCH MARKS, GENERAL MARKET INCREASE, PUBLISHED PRICE LISTS. SUCH REQUESTS FOR AND INCREASE SHOULD BE RECEIVED IN WRITING BY THE DIRECTOR OF PURCHASING AT LEAST 30 DAYS IN ADVANCE OF THE EFFECTIVE DATE OF THE INCREASE. ANY TIME THE VENDOR REQUESTS A PRICE ADJUSTMENT, THE PURCHASING DIVISION MAY EITHER ACCEPT THE PRICE ADJUSTMENT AND AMEND THE CONTRACT ACCORDINGLY OR REJECT THE ADJUSTMENT IN ITS ENTIRETY AND CANCEL THE CONTRACT.</p> <p>PIGGYBACKING PROVISION            IN ACCORDANCE WITH 5A-3-19 OF THE CODE OF WEST VIRGINIA THE COMMODITIES OR SERVICES CONTRACTED FOR HEREIN SHALL BE AVAILABLE TO ALL LOCAL GOVERNMENT BODIES IN ACCORDANCE WITH THE SAME PRICES, TERMS AND CONDITIONS AFFORDED TO THE STATE OF WEST VIRGINIA. IN THE EVENT ANY VENDOR DOES NOT WISH TO EXTEND THE ABOVE PRICES, TERMS AND CONDITIONS OF HIS BID AND SUBSEQUENT CONTRACT TO ALL STATE AGENCIES AND POLITICAL SUB-DIVISIONS OF THE STATE, HE MUST SO INDICATE IN A CLEAR AND UNAMBIGUOUS MANNER IN HIS BID. THIS INDICATION DOES NOT PREJUDICE THE AWARD OF THE CONTRACT. IF A VENDOR DOES NOT INDICATE HIS REFUSAL TO EXTEND THE PRICES, TERMS AND CONDITIONS OF HIS BID TO OTHER ENTITIES OF THE STATE HE IS BOUND TO EXTEND THEM UPON ISSUANCE OF A PURCHASE ORDER BY THESE ENTITIES.</p> <p>OTHER ORGANIZATIONAL ENTITIES USING THIS PROVISION OF THE CONTRACT SHALL DO SO WITHOUT ANY INVOLVEMENT OF THE DIVISION OF HIGHWAYS. THAT IS, THE ENTITY SHALL MAKE ITS OWN PURCHASE ARRANGEMENTS WITH THE VENDOR AND SHALL MAKE ITS OWN ARRANGEMENTS FOR PAYMENT.</p> <p>VENDOR PREFERENCE CERTIFICATE            CERTIFICATION AND APPLICATION* IS HEREBY MADE FOR</p>						

SEE REVERSE SIDE FOR TERMS AND CONDITIONS

SIGNATURE <i>Robert Smith</i>	TELEPHONE	DATE
TITLE	FEIN	ADDRESS CHANGES TO BE NOTED ABOVE

WHEN RESPONDING TO RFQ, INSERT NAME AND ADDRESS IN SPACE ABOVE LABELED 'VENDOR'



State of West Virginia  
 Department of Administration  
 Purchasing Division  
 2019 Washington Street East  
 Post Office Box 50130  
 Charleston, WV 25305-0130

# Request for Quotation

RFQ NUMBER:  
 707EC012

PAGE:  
 5

ADDRESS CORRESPONDENCE TO ATTENTION OF:  
 JOHN JOHNSTON  
 304-558-2402

RFQ COPY  
 TYPE NAME/ADDRESS HERE

VENDOR

SHIP TO

DIVISION OF HIGHWAYS  
 EQUIPMENT DIVISION  
 ROUTE 33  
 BRUSHY FORK ROAD  
 BUCKHANNON, WV  
 26201 304-472-1750

DATE PRINTED	TERMS OF SALE	SHIP VIA	F.O.B.	FREIGHT TERMS
11/21/2006				

BID OPENING DATE: 12/27/2006 BID OPENING TIME 01:30PM

LINE	QUANTITY	UOP	QAT NO	ITEM NUMBER	UNIT PRICE	AMOUNT
<p>PREFERENCE IN ACCORDANCE WITH WEST VIRGINIA CODE, 5A-3-37 (DOES NOT APPLY TO CONSTRUCTION CONTRACTS).</p> <p>A. APPLICATION IS MADE FOR 2.5% PREFERENCE FOR THE REASON CHECKED:</p> <p>( ) BIDDER IS AN INDIVIDUAL RESIDENT VENDOR AND HAS RESIDED CONTINUOUSLY IN WEST VIRGINIA FOR FOUR (4) YEARS IMMEDIATELY PRECEDING THE DATE OF THIS CERTIFICATION; OR</p> <p>(XX) BIDDER IS A PARTNERSHIP, ASSOCIATION OR CORPORATION RESIDENT VENDOR AND HAS MAINTAINED ITS HEAD-QUARTERS OR PRINCIPAL PLACE OF BUSINESS CONTINUOUSLY IN WEST VIRGINIA FOR FOUR (4) YEARS IMMEDIATELY PRECEDING THE DATE OF THIS CERTIFICATION; OR 80% OF THE OWNERSHIP INTEREST OF BIDDER IS HELD BY ANOTHER INDIVIDUAL, PARTNERSHIP, ASSOCIATION OR CORPORATION RESIDENT VENDOR WHO HAS MAINTAINED ITS HEADQUARTERS OR PRINCIPAL PLACE OF BUSINESS CONTINUOUSLY IN WEST VIRGINIA FOR FOUR (4) YEARS IMMEDIATELY PRECEDING THE DATE OF THIS CERTIFICATION; OR</p> <p>( ) BIDDER IS A CORPORATION NONRESIDENT VENDOR WHICH HAS AN AFFILIATE OR SUBSIDIARY WHICH EMPLOYS A MINIMUM OF ONE HUNDRED STATE RESIDENTS AND WHICH HAS MAINTAINED ITS HEADQUARTERS OR PRINCIPAL PLACE OF BUSINESS WITHIN WEST VIRGINIA CONTINUOUSLY FOR THE FOUR (4) YEARS IMMEDIATELY PRECEDING THE DATE OF THIS CERTIFICATION.</p> <p>B. APPLICATION IS MADE FOR 2.5% PREFERENCE FOR THE REASON CHECKED:</p> <p>(XX) BIDDER IS A RESIDENT VENDOR WHO CERTIFIES THAT, DURING THE LIFE OF THE CONTRACT, ON AVERAGE AT LEAST</p>						

SEE REVERSE SIDE FOR TERMS AND CONDITIONS

SIGNATURE <i>Bubba Smith</i>	TELEPHONE	DATE
TITLE	FEIN	ADDRESS CHANGES TO BE NOTED ABOVE

WHEN RESPONDING TO RFQ, INSERT NAME AND ADDRESS IN SPACE ABOVE LABELED 'VENDOR'



State of West Virginia  
 Department of Administration  
 Purchasing Division  
 2019 Washington Street East  
 Post Office Box 50130  
 Charleston, WV 25305-0130

# Request for Quotation

RFQ NUMBER  
 707EC012

PAGE  
 6

ADDRESS CORRESPONDENCE TO ATTENTION OF  
 JOHN JOHNSTON  
 304-558-2402

RFQ COPY  
 TYPE NAME/ADDRESS HERE

V  
E  
N  
D  
O  
R

S  
H  
I  
P  
T  
O

DIVISION OF HIGHWAYS  
 EQUIPMENT DIVISION  
 ROUTE 33  
 BRUSHY FORK ROAD  
 BUCKHANNON, WV  
 26201 304-472-1750

DATE PRINTED 11/21/2006	TERMS OF SALE	SHIP VIA	F.O.B.	FREIGHT TERMS
----------------------------	---------------	----------	--------	---------------

BID OPENING DATE: 12/27/2006 BID OPENING TIME 01:30PM

LINE	QUANTITY	UOP	CAT. NO.	ITEM NUMBER	UNIT PRICE	AMOUNT
<p>75% OF THE EMPLOYEES WORKING ON THE PROJECT BEING BID ARE RESIDENTS OF WEST VIRGINIA WHO HAVE RESIDED IN THE STATE CONTINUOUSLY FOR THE TWO YEARS IMMEDIATELY PRECEDING SUBMISSION OF THIS BID;            OR            ( ) BIDDER IS A NONRESIDENT VENDOR EMPLOYING A MINIMUM OF ONE HUNDRED STATE RESIDENTS OR IS A NONRESIDENT VENDOR WITH AN AFFILIATE OR SUBSIDIARY WHICH MAINTAINS ITS HEADQUARTERS OR PRINCIPAL PLACE OF BUSINESS WITHIN WEST VIRGINIA EMPLOYING A MINIMUM OF ONE HUNDRED STATE RESIDENTS WHO CERTIFIES THAT, DURING THE LIFE OF THE CONTRACT, ON AVERAGE AT LEAST 75% OF THE EMPLOYEES OR BIDDERS' AFFILIATE'S OR SUBSIDIARY'S EMPLOYEES ARE RESIDENTS OF WEST VIRGINIA WHO HAVE RESIDED IN THE STATE CONTINUOUSLY FOR THE TWO YEARS IMMEDIATELY PRECEDING SUBMISSION OF THIS BID.</p> <p>BIDDER UNDERSTANDS IF THE SECRETARY OF TAX &amp; REVENUE DETERMINES THAT A BIDDER RECEIVING PREFERENCE HAS FAILED TO CONTINUE TO MEET THE REQUIREMENTS FOR SUCH PREFERENCE, THE SECRETARY MAY ORDER THE DIRECTOR OF PURCHASING TO: (A) RESCIND THE CONTRACT OR PURCHASE ORDER ISSUED; OR (B) ASSESS A PENALTY AGAINST SUCH BIDDER IN AN AMOUNT NOT TO EXCEED 5% OF THE BID AMOUNT AND THAT SUCH PENALTY WILL BE PAID TO THE CONTRACTING AGENCY OR DEDUCTED FROM ANY UNPAID BALANCE ON THE CONTRACT OR PURCHASE ORDER.</p> <p>BY SUBMISSION OF THIS CERTIFICATE, BIDDER AGREES TO DISCLOSE ANY REASONABLY REQUESTED INFORMATION TO THE PURCHASING DIVISION AND AUTHORIZES THE DEPARTMENT OF TAX AND REVENUE TO DISCLOSE TO THE DIRECTOR OF PURCHASING APPROPRIATE INFORMATION VERIFYING THAT BIDDER HAS PAID THE REQUIRED BUSINESS TAXES, PROVIDED THAT SUCH INFORMATION DOES NOT CONTAIN THE AMOUNTS OF TAXES PAID NOR ANY OTHER INFORMATION DEEMED BY THE TAX</p>						

SEE REVERSE SIDE FOR TERMS AND CONDITIONS

SIGNATURE <i>Robert Johnston</i>	TELEPHONE	DATE
TITLE	FEIN	ADDRESS CHANGES TO BE NOTED ABOVE

WHEN RESPONDING TO RFQ, INSERT NAME AND ADDRESS IN SPACE ABOVE LABELED 'VENDOR'



State of West Virginia  
 Department of Administration  
 Purchasing Division  
 2019 Washington Street East  
 Post Office Box 50130  
 Charleston, WV 25305-0130

# Request for Quotation

RFQ NUMBER  
**707EC012**

PAGE  
**7**

ADDRESS CORRESPONDENCE TO ATTENTION OF  
**JOHN JOHNSTON**  
**304-558-2402**

RFQ COPY  
 TYPE NAME/ADDRESS HERE

VENDOR

SHIP TO

DIVISION OF HIGHWAYS  
 EQUIPMENT DIVISION  
 ROUTE 33  
 BRUSHY FORK ROAD  
 BUCKHANNON, WV  
 26201 304-472-1750

DATE PRINTED <b>11/21/2006</b>	TERMS OF SALE	SHIP VIA	F.O.B.	FREIGHT TERMS
-----------------------------------	---------------	----------	--------	---------------

BID OPENING DATE: **12/27/2006** BID OPENING TIME **01:30PM**

LINE	QUANTITY	UOP	CAT. NO.	ITEM NUMBER	UNIT PRICE	AMOUNT
<p>COMMISSIONER TO BE CONFIDENTIAL.</p> <p>UNDER PENALTY OF LAW FOR FALSE SWEARING (WEST VIRGINIA CODE 61-5-3), BIDDER HEREBY CERTIFIES THAT THIS CERTIFICATE IS TRUE AND ACCURATE IN ALL RESPECTS; AND THAT IF A CONTRACT IS ISSUED TO BIDDER AND IF ANYTHING CONTAINED WITHIN THIS CERTIFICATE CHANGES DURING THE TERM OF THE CONTRACT, BIDDER WILL NOTIFY THE PURCHASING DIVISION IN WRITING IMMEDIATELY.</p> <p>BIDDER: Benson Manufacturing, Inc.-----</p> <p>DATE: --12/22/2006-----</p> <p>SIGNED: <i>Bella Smith</i>-----</p> <p>TITLE: --Municipal Sales-----</p> <p>* CHECK ANY COMBINATION OF PREFERENCE CONSIDERATION(S) IN EITHER "A" OR "B", OR BOTH "A" AND "B" WHICH YOU ARE ENTITLED TO RECEIVE. YOU MAY REQUEST UP TO THE MAXIMUM 5% PREFERENCE FOR BOTH "A" AND "B". (REV. 12/00)</p> <p>NOTICE</p> <p>A SIGNED BID MUST BE SUBMITTED TO:</p> <p>DEPARTMENT OF ADMINISTRATION          PURCHASING DIVISION          BUILDING 15          2019 WASHINGTON STREET, EAST</p>						

SEE REVERSE SIDE FOR TERMS AND CONDITIONS

SIGNATURE	TELEPHONE	DATE
TITLE	FEIN	ADDRESS CHANGES TO BE NOTED ABOVE

WHEN RESPONDING TO RFQ, INSERT NAME AND ADDRESS IN SPACE ABOVE LABELED 'VENDOR'





State of West Virginia  
 Department of Administration  
 Purchasing Division  
 2019 Washington Street East  
 Post Office Box 50130  
 Charleston, WV 25305-0130

# Request for Quotation

RFQ NUMBER  
**707EC012**

PAGE  
**8**

ADDRESS CORRESPONDENCE TO ATTENTION OF  
**JOHN JOHNSTON  
 304-558-2402**

VENDOR

RFQ COPY  
 TYPE NAME/ADDRESS HERE

SHIP TO

DIVISION OF HIGHWAYS  
 EQUIPMENT DIVISION  
 ROUTE 33  
 BRUSHY FORK ROAD  
 BUCKHANNON, WV  
 26201 304-472-1750

DATE PRINTED <b>11/21/2006</b>	TERMS OF SALE	SHIP VIA	F.O.B.	FREIGHT TERMS
-----------------------------------	---------------	----------	--------	---------------

BID OPENING DATE: **12/27/2006** BID OPENING TIME **01:30PM**

LINE	QUANTITY	UOP	CAT NO	ITEM NUMBER	UNIT PRICE	AMOUNT
				CHARLESTON, WV 25305-0130		
<p>THE BID SHOULD CONTAIN THIS INFORMATION ON THE FACE OF THE ENVELOPE OR THE BID MAY NOT BE CONSIDERED:</p> <p>SEALED BID</p> <p>BUYER: 33</p> <p>RFQ. NO.: 707EC012</p> <p>BID OPENING DATE AND TIME</p> <p>PLEASE PROVIDE A FAX NUMBER IN CASE IT IS NECESSARY TO CONTACT YOU REGARDING YOUR BID:</p> <p>----- (304)-489-2828 -----</p> <p>CONTACT PERSON (PLEASE PRINT CLEARLY):</p> <p>----- Bubba Smith -----</p>						

SEE REVERSE SIDE FOR TERMS AND CONDITIONS

SIGNATURE <i>Bubba Smith</i>	TELEPHONE	DATE
TITLE	FEIN	ADDRESS CHANGES TO BE NOTED ABOVE

WHEN RESPONDING TO RFQ, INSERT NAME AND ADDRESS IN SPACE ABOVE LABELED 'VENDOR'



State of West Virginia  
 Department of Administration  
 Purchasing Division  
 2019 Washington Street East  
 Post Office Box 50130  
 Charleston, WV 25305-0130

# Request for Quotation

BFO NUMBER  
**707EC012**

PAGE  
**9**

ADDRESS CORRESPONDENCE TO ATTENTION OF:  
**JOHN JOHNSTON**  
**304-558-2402**

RFQ COPY  
 TYPE NAME/ADDRESS HERE

VENDOR

SHIP TO

**DIVISION OF HIGHWAYS**  
**EQUIPMENT DIVISION**  
**ROUTE 33**  
**BRUSHY FORK ROAD**  
**BUCKHANNON, WV**  
**26201**                      **304-472-1750**

DATE PRINTED <b>11/21/2006</b>	TERMS OF SALE <b>Net 30 Days</b>	SHIP VIA <b>Benson</b>	F.O.B. <b>Buckhannon, WV</b>	FREIGHT TERMS <b>Included</b>
BID OPENING DATE: <b>12/27/2006</b>		BID OPENING TIME <b>01:30PM</b>		

LINE	QUANTITY	UOP	CAT NO.	ITEM NUMBER	UNIT PRICE	AMOUNT
***** THIS IS THE END OF RFQ 707EC012 ***** TOTAL:						<b>\$25,395.00</b>

SEE REVERSE SIDE FOR TERMS AND CONDITIONS

SIGNATURE <i>Betha Smith</i>	TELEPHONE <b>(304)-489-9020</b>	DATE <b>12/22/2006</b>
TITLE <b>Municipal Sales</b>	FEIN <b>709042146</b>	ADDRESS CHANGES TO BE NOTED ABOVE

WHEN RESPONDING TO RFQ, INSERT NAME AND ADDRESS IN SPACE ABOVE LABELED 'VENDOR'

WEST VIRGINIA DEPARTMENT OF TRANSPORTATION  
DIVISION OF HIGHWAYS  
EQUIPMENT DIVISION

PROCUREMENT SPECIFICATIONS  
NO. 254-1-K

48 FOOT ALUMINUM PLATFORM TRAILER

1.0 PURPOSE

It is the purpose of these specifications to describe a 48 Foot Aluminum Platform Trailer (hereinafter referred to as a "trailer" or a "unit") to be purchased for use by the West Virginia Division of Highways (DOH) on an Open End Contract basis.

2.0 BIDDING PROCEDURES

The current purchasing procedures regarding bidding as established by the Department of Administration, Purchasing Division, shall apply. Failure to submit the "Request for Quotation" forms, complete in its entirety and according to directions indicated, may subject the bidder to disqualification. Each bid submitted shall also be accompanied by a Bidder's Evaluation Report completed in detail. FAILURE TO SUBMIT THE BIDDER'S EVALUATION REPORT, COMPLETE IN ITS ENTIRETY, MAY RESULT IN AUTOMATIC DISQUALIFICATION.

3.0 SPECIFICATIONS

The specifications named herein, mandatory and non-mandatory, establish the acceptable level of quality only and are not intended to reflect a preference or favor any particular brand or vendor.

3.1 EXCEPTIONS TO NON-MANDATORY SPECIFICATIONS

Exception to a non-mandatory unit specification may be made by the bidder, providing the exception is not available from the manufacturer. Any such exception must be noted on the bidder's evaluation report and should be accompanied by supporting documentation/literature from the manufacturer. Any exception must be indicated on a separate attachment to the bidder's evaluation report and labeled as "Exception to Specifications". The state reserves the right to determine whether the stated exception does or does not reduce the quality and performance of the unit. Failure to provide information for any exceptions may be grounds for rejection of the bid. The state reserves the right to waive minor irregularities in bids or specifications in accordance with §148-1-4(f) of the WV Legislative Rules and Regulations.

### 3.2 MANDATORY SPECIFICATIONS

All specifications preceded by "shall and/or must" or are stated as a "minimum and/or maximum" are mandatory. Any bid failing to meet any mandatory item shall be immediately disqualified. Failure to respond in the appropriate evaluation section may also be grounds for immediate disqualification at the discretion of the State.

A mandatory pre-bid conference is scheduled for this equipment purchase as stated in the RFQ. Vendors having products with variations or exceptions in specified mandatory items are expected to address any such variations or exceptions during the pre-bid conference. The State shall review and consider any such variation or exception, and may at its sole discretion, issue an addendum to change mandatory specifications deemed to be in the State's best interest. Bids from any vendor failing to attend the mandatory pre-bid shall be disqualified. Bids containing any variation or exception to a mandatory specification that was not addressed during the pre-bid conference and accepted by the issuance of an Addendum shall be disqualified.

### 4.0 REPRESENTATIVE UNIT FOR TEST

The successful vendor must (if specified) provide DOH one (1) completed representative unit to be observed and evaluated on the first order only to insure compliance with specification. If requested, the time period for testing and evaluation shall be seven (7) working days following receipt of the unit. DOH will incur no obligation for deterioration of surfaces, finishes, seals, and mechanical or electrical parts on the unit resulting from operation and testing within the limits of these specifications; nor will DOH incur obligation for damage to the unit resulting from failure to meet specifications when due care and attention is given by DOH and testing is done within the limits of these specifications. Failure of the pilot unit to satisfactorily meet specifications as bid shall be cause for cancellation of the purchase order, and return of the delivered unit along with all associated equipment to the vendor at the vendor's expense.

### 4.1 CONDITION OF UNIT(S) UPON DELIVERY

All units must arrive at the prescribed delivery point having been completely preserviced with oil, lubricants, and coolant. All prescribed precautions pertaining to first operations and break-in of the unit are to be posted conspicuously on the unit for ready observance by the operator.

### 4.2 DELIVERY

Delivery point of the completely assembled representative unit will be the DOH, Equipment Division, Route 33 at Brushy Fork Road, Buckhannon, West Virginia (26201).

The vendor is responsible for guaranteeing delivery of the completed units within the time specified and agreed to by the State. Delivery is preferred within 90 days. The vendor is responsible for establishing and coordinating delivery terms with allied manufacturers or suppliers. Delivery terms shall be stated in the bid and the State

reserves the right to accept or negotiate such terms. Failure to reach an agreement may result in rejection of the bid. The successful bidder shall provide their manufacturer's confirmation of the order to the WVDOH contact person within seven (7) working days after receiving the approved purchase order.

A completed pilot model for inspection must be provided within 45 calendar days after the date of the purchase agreement by the successful vendor.

Delivery is an integral part of this specification and failure to comply will be cause to initiate a D.O.T. Administrative Form WV-82, Vendor Performance Form. The WV-82 Form will provide a means of officially notifying the Purchasing Division and the vendor of unsatisfactory performance; such as late deliveries, poor service, inadequate parts supplies, etc.

The decision to initiate subject Form will be at the sole discretion of the D.O.H. Commissioner's established Equipment Review Board.

Issuance of the WV-82 Vendor Complaint Form on unsatisfactory delivery against any vendor will be cause to refuse to consider similar items from those vendors on future Request For Quotations.

(NOTE: Delivery time could be altered due to labor strikes, severe inclement weather conditions, etc.)

## 5.0 AWARD CRITERIA

- 5.1 DOH will recommend the award in accordance with the RFQ evaluation criteria described in the requisition. The award shall be made to the lowest unit cost vendor that meets or exceeds the specifications.

Prices for the units shall be in quantities of 1-5, 6-10, 11-20, and 21 and over. However, for evaluation purposes, we will use quantities 1-5. DOH reserves the right to place multiple orders in any quantity.

## 6.0 SPECIFICATIONS AND GUIDELINES - GENERAL

### 6.1 IDENTIFICATION OF THE UNIT BEING PROPOSED

The bidder must identify the unit by manufacturer, model, series, and year of manufacture, in the bid to enable identification by DOH in the manufacturer's specifications of the proposed unit. The bidder will submit complete descriptive literature of the proposed unit, to establish that the bid is the manufacturer's most current model, including latest engineering improvements, which have been, or will imminently be, regularly advertised and sold on the open market. The unit specified herein and offered to be manufactured after January 1, 2006 and be clearly identified and marked with date of manufacture.

## 6.2 OPERATING AND SERVICE MANUALS AND PARTS LISTS

An operator's manual must be included with each unit upon delivery. A "line sheet" (if applicable) and Equipment Preventative Maintenance Questionnaire (as shown in X6.2 of the Bidder's Evaluation Report) must be with pilot unit upon delivery. In addition, there must be 12 service, shop, or maintenance manuals; ten (10) to be distributed to the Districts and two (2) for the Equipment Division. Also, there must be 14 parts manuals; ten (10) to be distributed to the Districts and four (4) for Equipment Division use. CD ROM is preferred in lieu of parts manuals.

\* NOTE: MANUALS SHALL BE DELIVERED UPON COMPLETION OF DELIVERY OF TOTAL UNITS. FAILURE TO DO SO WILL DELAY PAYMENT.

## 6.3 TRAINING:

Manufacturers and/or dealers will be required to stage a thorough seminar on the subjects of Preventative Maintenance, Operator and Mechanic Training. In order to keep the operators and mechanics updated, the successful vendor shall conduct training with each purchase order against this open end contract. Training is preferred within 2 working days after delivery of the pilot unit on the individual purchase order.

Manufacturers and/or dealers shall be required to furnish the Training Academy with one (1) Operator's Manual.

The seminar to be held at the W. Va. Division of Highways, Equipment Division, Buckhannon, West Virginia.

## 6.4 PREVENTIVE MAINTENANCE AND OPERATOR PROCEDURES:

Manufacturers and/or dealers will be required to submit to the Equipment Division, in addition to the operating and service manuals, booklets and pamphlets explaining the Preventive Maintenance and Operator Procedures to be used by the operators of this equipment, and must include such things as daily prestart inspection procedure, service schedule, and routine maintenance required, safety precautions, etc.

The successful vendor shall furnish all training aids; i.e., videos, projectors, etc. required in conducting the training.

## 6.5 WARRANTY AND SERVICE POLICY

The Manufacturers warranty or service policy is to apply to the unit. Such warranty or service policy is to be recognized at any authorized unit dealer, representing manufacturer of proposed unit throughout the State of West Virginia. The applicable warranty or service policy will not be contingent upon obtaining routine service, lubrication, and servicing of the unit from factory authorized agencies. It will be the responsibility of the bidder to have available labor to repair or replace any defective replacement parts, components and materials, and to have available those replacement parts, components, and/or materials found to be defective during the terms of the

warranty period. The bidder should state the labor rates, locations where parts will be stocked, availability of parts, and discounts offered for parts, when terms of the warranty offer a pro-rated cost for parts and labor. In addition, the successful bidder should offer field work to repair or replace defective parts, components, and materials found to be defective during the terms of the warranty and should provide mechanic's travel rates, mileage charges, field mechanic rates, and any surcharge for miscellaneous items, if applicable, for field work during the warranty period. Submit to Division of Highways any technical or engineering improvements during the term of the warranty. The unit must be accompanied upon delivery by the unit's manufacturer's executed warranty or service policy.

A minimum two (2) year basic bumper to bumper warranty must be included with this unit.

THE "WARRANTY AND SERVICE POLICY QUESTIONNAIRE" ATTACHED IN THE BIDDER'S EVALUATION REPORT MUST BE COMPLETED IN ITS ENTIRETY BY THE SUCCESSFUL BIDDER OR MANUFACTURER PRIOR TO DELIVERY OF THE PILOT MODEL. (SEE SECTION X6.5 OF BIDDER'S EVALUATION REPORT).

#### 6.6 EVALUATION COMMITTEE REQUIREMENTS

Detailed component specifications, product literature, component models, required for specification compliance determination by the Evaluation Committee should be provided with each bid. Any information supplied that is contrary to/or conflicting with the specifications and/or attached Bidders Evaluation Report may be sufficient cause for rejection of bid.

#### 6.7 UNSPECIFIED ACCESSORIES & FEATURES

All parts, equipment, accessories, material, design and performance characteristics not specified herein, but which are necessary to provide a complete unit, must be furnished with each unit and required to conform to strength, quality of material, and quality of workmanship to those which are advertised and provided to the market in general by the unit industry.

All parts and accessories advertised and regularly supplied as standard shall be included, except those which would represent duplication of these specified, and except those which, by specification, are not to be furnished. All standard safety features, required by Federal and State Law, shall be included.

7.0 SPECIFICATIONS OF THE QUOTED UNIT ARE AS FOLLOWS:

This specification is intended to describe a 48 foot aluminum platform trailer. The trailer shall conform to these specifications, must be the manufacturers current model, including all component parts. It shall be a model that has been in use by the contracting/maintenance trade for at least four (4) years and must be capable of being towed over both improved and unimproved roads with a full capacity load.

7.1 Trailer to be tandem axle.

7.2 Capacity: 52,000 lbs. minimum in four (4) foot span with total GVW minimum 80,000 lbs.

7.3 Overall width shall be 102 inches

7.4 Front corner: Square or 45°

7.5 Frame:

7.5.1 The main carrying members minimum 52,000 lbs. in four (4) foot span.

7.5.2 Floor cross members: 4 ft. to 4 7/8 ft. 6061T6 on 16 to 22 inch centers.

7.6 Rear Frame:

7.6.1 Rear frame assembly to have two (2) integral stake pockets, two (2) rubber dock bumpers, and minimum 3/8 inch thick plate corner gussets for dock impact protection..

7.7 Bumpers:

7.7.1 Bumpers shall meet ICC regulations with two (2) outboard mount rubber dock bumpers

7.8 Platform:

7.8.1 Floor: Sturdy aluminum floor 1 1/8 inch minimum with three (3) apitong nailers secured by two (2) screws per board per cross member

7.8.2 Outer Side Rails: Minimum 5 1/2 inch deep, 6061-T6 extruded, 3 3/8 I.D. stake pockets on 24 inch centers, FMVSS compliant conspicuity tape mounted below rub rail

7.9 Axle Assemblies:

7.9.1 Axle to be intraax integral with HP straight spindle, HLS, or equal



7.10 Wheels and Tires:

7.10.1 The wheels to be oil type lubrication. Budd type disc wheels.

7.10.2 Tires to be steel belted radials. Manufacturers standard for GVW specified.

7.11 Brakes:

7.11.1 System shall include all necessary tubing, glad hands or connectors at the front of the trailer, reservoir of adequate capacity, relay emergency valve and air chamber at each of four (4) wheels.

7.11.2 Brake shoes shall be the internal expanding type with molded block lining 16-1/2 inches x 7 inches minimum.

7.11.3 Brakes shall be actuated by constant rise of "s" type cams. All precautions to be taken to prevent the brake components from being damaged by road hazards and tire chains during snow/ice season.

7.11.4 Trailer to be equipped with automatic slack adjusters.

7.11.5 Brake drums to be centrifuse

7.11.6 ABS system shall be 452M Meritor/Wabco or equal

7.12 Lighting System:

7.12.1 A complete 12 volt light system to be furnished with adequate clearance, stop, and tail lights, directional signals and reflectors with proper conspicuity striping.

7.12.2 All lights to be LED type.

7.13 Upper fifth wheel plate to be adequate in size for coupling with a standard size fifth wheel and/or full oscillation fifth wheel.

7.14 Kingpin .30 inch setting, bolted assembly, with standard upper coupler height of 49 inches to 50 inches.

7.15 Suspension:

7.15.1 Suspension to be Hendrickson Intraax AANT230 HP or equal with 122 inch spread tandem

7.15.2 Capacity of rear suspension to be 44,000 pounds minimum

7.15.3 Landing Gear: Shall have minimum 50,000 lbs. lift capacity with two (2) speed road side crank.

- 7.16 All features that are considered to be manufacturers standard equipment that are not specifically addressed above shall be provided.
- 7.17 Unit shall be delivered to WV DOH with all manufacturers recommended safety related decals and safety features intact.
- 7.18 Mud Flaps: Will be furnished by the West Virginia Division of Highways to be installed at vendors facility.
- 7.19 Paint:
- 7.19.1 Steel parts painted black, properly cleaned, two-part epoxy primer with acrylic enamel
- 7.19.2 In order to test the adhesion quality of the paint, the DOH may, at its option, require that the vendor measure adhesion by the criteria set forth in ASTM D3359-74, Method B. A rating of less than 4 on this test would be deemed unacceptable.
- 7.20 Vendor must certify that unit offered will meet or exceed the "Occupational Safety and Health Act of 1970" and subsequent amendments.
- 7.21 Advertising: No visible decals or name plates or painted on names other than the manufacturer or model number or trademark should appear on the exterior surface of the unit. Such logos created through the stamping or casting process of manufacture are accepted.

NOTE: Vendor should type Bidder's Evaluation Report

18

WEST VIRGINIA DEPARTMENT OF TRANSPORTATION  
DIVISION OF HIGHWAYS  
EQUIPMENT DIVISION

BIDDER'S EVALUATION REPORT

PROCUREMENT SPECIFICATIONS FOR OPEN END CONTRACT  
NO. 254-1-K

48 FOOT ALUMINUM PLATFORM TRAILER

NOTE TO BIDDER: Procurement Specification No. 254-1-K, Paragraph 2.0 recommends the completion and submittal of this Report with your bid. Purpose of this Report is to enable the West Virginia Division of Highways Evaluation Committee to make full and fair evaluation of the bid.  
FAILURE TO SUBMIT THIS REPORT, COMPLETE IN ITS ENTIRETY, MAY SUBJECT THE BIDDER TO DISQUALIFICATION.

Reference Requisition No.: 707EC012

Bidder's Name: Benson Manufacturing, Inc.

Address: RT 14 & I-77 South P.O. BOX 970 Mineral Wells, WV 26150

Telephone Number: (304)-489-9020

Years Bidder has been registered to do business with the State of West Virginia: 10 + YRS.

Years Company has been an authorized dealer for proposed unit: 20 YRS.

X4.2 DELIVERY:

X4.2.1 Delivery date of completed representative unit: 45 - 90 Calendar Days After Date of Purchase Agreement

X4.2.2 Delivery date of balance of completed units: 90 Calendar Days After Date of Purchase Agreement

X5.0 AWARD CRITERIA;

X5.1	Prices in quantities of	1-5	<u>\$25,395</u>	per unit
		6-10	<u>\$25,395</u>	per unit
		11-20	<u>\$25,395</u>	per unit
		21 and over	<u>\$25,395</u>	per unit

X6.0 SPECIFICATIONS - GENERAL

X6.1 Manufacturer, model, series, and date of manufacture of proposed unit:

Benson AF5244810250 08 Model Year

Is descriptive literature, fully describing proposed unit attached to your bid? xx YES \_\_\_\_ NO

If not, why? \_\_\_\_\_

X6.2 Will the required number of service manuals, and complete parts list be delivered to the Equipment Division at Buckhannon upon completion of delivery of total units? xx YES \_\_\_\_ NO

Will the required Equipment Preventive Maintenance Form (Section X6.2 of Bidders Evaluation Report) be provided upon inspection of the pilot unit? xx YES \_\_\_\_ NO

X6.2  
2-10-00

EQUIPMENT PREVENTATIVE MAINTENANCE QUESTIONNAIRE

THIS FORM MUST BE COMPLETED IN ITS ENTIRETY BY SUCCESSFUL BIDDER OR MANUFACTURER=S TECHNICAL REPRESENTATIVE PRIOR TO DELIVERY OF PILOT MODEL TO THE WVDOH.

DESCRIPTION: 48' x 102" Aluminum Flat Trailer MAKE: Benson

MODEL: 524 YEAR: 2008 PURCHASE AMOUNT: \$25,395

ENGINE: MAKE: \_\_\_\_\_ MODEL: \_\_\_\_\_ FUEL TYPE: \_\_\_\_\_

HORSEPOWER: \_\_\_\_\_ CYLINDER: \_\_\_\_\_ ENGINE SERIAL: \_\_\_\_\_

COOLING SYSTEM CAPACITY: \_\_\_\_\_

BELTS: DESCRIPTION: \_\_\_\_\_ PART NUMBERS: \_\_\_\_\_

\_\_\_\_\_  
\_\_\_\_\_

GVW: 80,000# AXLE CAPACITY: FRONT: \_\_\_\_\_ REAR: \_\_\_\_\_

TIRES: FRONT MAKE & SIZE: Michelin XTE 11RX22.5

REAR MAKE & SIZE: \_\_\_\_\_

DIMENSIONS OF UNIT: LENGTH: 48' WIDTH: 102" LENGTH: \_\_\_\_\_

VENDOR CONTACT PERSON: Bubba Smith PHONE: (304)-489-9020

PARTS:

BATTERY MAKE: \_\_\_\_\_ MODEL: \_\_\_\_\_ CCA: \_\_\_\_\_

TOP OR SIDE POST: \_\_\_\_\_ DIMENSIONS: LENGTH \_\_\_\_\_ WIDTH \_\_\_\_\_ HEIGHT \_\_\_\_\_

SPARK PLUGS OR FUEL INJECTORS MAKE: \_\_\_\_\_ PART # \_\_\_\_\_

FUEL PUMP OR INJECTION PUMP MAKE: \_\_\_\_\_ MODEL: \_\_\_\_\_

ALTERNATOR MAKE: \_\_\_\_\_ PART #: \_\_\_\_\_

STARTER MAKE: \_\_\_\_\_ PART #: \_\_\_\_\_

TURBO CHARGER MAKE: \_\_\_\_\_ PART #: \_\_\_\_\_

TRANS. MAKE: \_\_\_\_\_ MODEL: \_\_\_\_\_ AUTO/MANUAL: \_\_\_\_\_

HYDRAULIC PUMP MAKE: \_\_\_\_\_ MODEL: \_\_\_\_\_

FILTERS	MAKE	PART NO.	LUBRICANT	MANUFACTURER TYPE
OIL	_____	_____	ENGINE	_____
AIR INNER	_____	_____	TRANSMISSION	_____
AIR OUTER	_____	_____	POWER STEERING	_____
FUEL PRIMARY	_____	_____	HYDRAULIC	_____
FUEL SECONDARY	_____	_____	DIFFERENTIALS	_____
COOLANT	_____	_____	BRAKE FLUID	_____
HYDRAULIC	_____	_____	COOLANT	_____
OTHER	_____	_____	OTHER	_____

X6.3 TRAINING:

Will training seminar be conducted on Preventive Maintenance, Operator and Mechanic Training XX YES \_\_\_\_ NO

Will you conduct training with each purchase order against this open end contract? XX YES \_\_\_\_ NO

Will training be conducted within 2 working days from the delivery of the pilot unit on the individual purchase order? XX YES \_\_\_\_ NO

If NO, explain time frame \_\_\_\_\_

Will an Operator's Manual be furnished to the Training Academy? XX YES \_\_\_\_ NO

X6.4 If you are the successful vendor, will you furnish all training aids, i.e., videos, projectors, required in conducting the training? XX YES \_\_\_\_ NO

X6.4.1 Will all manuals, booklets, etc. explaining preventive maintenance, operator procedures, and service schedule be delivered with each unit? XX YES \_\_\_\_ NO

If NO, explain \_\_\_\_\_

X6.5 WARRANTY AND SERVICE POLICY

Will the warranty and service you provide comply with all areas as stated in Section 6.5 of specifications XX YES \_\_\_\_ NO

Is warranty literature attached? XX YES \_\_\_\_ NO

Is there a minimum two (2) year bumper to bumper basic warranty? XX YES \_\_\_\_ NO

Describe: See Attachment

X6.5 WARRANTY AND SERVICE POLICY QUESTIONNAIRE  
THIS FORM MUST BE COMPLETED IN ITS ENTIRETY BY THE SUCCESSFUL BIDDER OR MANUFACTURERS TECHNICAL REPRESENTATIVE PRIOR TO DELIVERY OF PILOT MODEL TO THE WVDOH (If additional lines are needed, make copies of form.)

1. Define the terms of the standard warranty. If not offered, so state. (Attach copy)

See Attach Copy

2. Define warranty service to be performed at DOH facilities and warranty service to be performed at manufacturer's representative facility. List name and location of manufacturer's representative.

Benson Manufacturing Inc.

Mineral Wells, WV

3. List locations for parts inventories that are within the State of West Virginia. Also, list availability levels, if known.

Benson Manufacturing Inc.

Mineral Wells, WV

4. During the term of warranty, list the guarantee discount to manufacturer's published list price for parts that bidder will sell the parts to owner.

A.	Terms: Net 30	Manufacturer's published list price less:	<u>25</u>	% discount
B.	Terms: Net 60	Manufacturer's published list price less:	<u>20</u>	% discount
C.	Terms: Net 90	Manufacturer's published list price less:	<u>10</u>	% discount

5. During the term of warranty, will all manufacturers or engineering improvements be submitted to Division of Highways? XX YES      NO

6. During the term of warranty, list the guaranteed rates charged for repair to the unit.

- A. Shop Rate \$ 60.00 per mechanic hour
- B. Travel Time Charge \$ 60.00 per mechanic hour  
(Specify if one-way) \_\_\_\_\_; port to port Both Ways
- C. Mileage Charge \$ 0 per vehicle mile  
(Specify if one-way) \_\_\_\_\_; port to port \_\_\_\_\_
- D. Field Mechanic Rate \$ 60.00 per mechanic hour
- E. Specify period of time that prices are in effect: 1 year 1/07 - 1/08
- F. Surcharge for miscellaneous items: 0 %

## X6.6 EVALUATION COMMITTEE REQUIREMENTS

Is all component specifications, product literature, component models provided for Evaluation Committee bid determination?  YES  NO

X6.7 Will all parts, equipment, accessories, material, design and performance characteristics not specified herein, but which are necessary to provide a complete unit, be furnished with the unit and conform in strength, quality of material, and quality of workmanship to those which are advertised and provided to the market in general by the unit industry?  YES  NO

X6.7.1 Are all parts and accessories adequate and regularly supplied as standard to be included except those which may be duplications of specifications herein, and except these by specification are not to be furnished?  YES  NO

X6.7.2 Are all standard safety features that are required by Federal and State statutes of law included?  YES  NO

## X7.0 SPECIFICATIONS OF THE QUOTED UNIT

The bidder should complete the following schedule in order for the Division to compare the actual bid unit to the specifications. Should the bidder except a requirement, then such exception may be only on the basis that such feature is not offered by the manufacturer. The Division will have the sole discretion as to whether the bidder's substitution meets the requirements of the specifications.

Manufacturer: Benson Model: AF5244810250

Is it the manufacturers current model, including all component parts, and has been used by the contracting/maintenance trade for at least four (4) years and capable of being towed over both improved and unimproved roads with a full capacity load.

YES  NO

X7.1 Is the trailer tandem axle

YES  NO

X7.2 Capacity 52,000 lbs. in four (4) span with total GVW 80,000 lbs.

X7.3 Overall width: 102" inches

X7.4 Front corner: Square  YES  NO OR 45°  YES  NO

X7.5 Frame:

X7.5.1 The main carrying members 52,000 lbs. in four (4) foot span  YES  NO



- X7.5.2 Floor cross members: 4Ft. To 4 7/8 Ft. 6061T6 (Verbage in Spec.)  
 on 16-22 inch centers Spec Should Read XX YES      NO  
 ( 4in. X 4 7/8 in. 6061T6)
- X7.6 Rear Frame:
- X7.6.1 Does rear frame assembly have two (2) integral stake pockets, two (2) rubber dock bumpers, and minimum 3/8 inch thick plate corner gussets for dock impact protection  
XX YES      NO
- X7.7 Bumpers:
- X7.7.1 Do bumpers meet ICC regulations with two (2) outboard mount rubber dock bumpers  
XX YES      NO
- X7.8 Platform:
- X7.8.1 Is floor sturdy aluminum and minimum of 1 1/8 inch XX YES      NO  
 Are there three (3) apitong nailers secured by two (2) screws per board per cross Member  
XX YES      NO
- X7.8.2 Outer Side Rails: Depth: 5 1/2"inch 6061-T6 extruded XX YES      NO  
 3 3/8 I.D. stake pockets on 24 inch centers and FMVSS compliant conspicuity tape mounted below rub rail  
XX YES      NO
- X7.9 Axle Assemblies:
- X7.9.1 Is axle intraax integral with HP straight spindle, HLS, or equal XX YES      NO
- X7.10 Wheels and Tires:
- X7.10.1 Do wheels have oil type lubrication XX YES      NO  
 Budd type disc wheels XX YES      NO
- X7.10.2 Are tires steel belted radials XX YES      NO  
 Are they manufacturers standard for GVW specified XX YES      NO  
 Manufacturer: Michelin XTE 11R22.5 14ply
- X7.11 Brakes:
- X7.11.1 Does system include all necessary tubing, glad hands or connectors at the front of the trailer, reservoir of adequate capacity, relay emergency valve and air chamber at each of four (4) wheels  
XX YES      NO

X7.11.2 Are brake shoes the internal expanding type with molded block lining XX YES \_\_\_ NO

Size: 16 1/2 X 7

X7.11.3 Are brakes actuated by constant rise of "s" type cams XX YES \_\_\_ NO

Are precautions taken to prevent the brake components from being damaged by road hazards and tire chains during snow/ice season XX YES \_\_\_ NO

X7.11.4 Is trailer equipped with automatic slack adjusters XX YES \_\_\_ NO

X7.11.5 Are brake drums centrifuse XX YES \_\_\_ NO

X7.11.6 ABS system: Wabco 4S/2m

X7.12 Lighting:

X7.12.1 Is a complete 12 volt light system furnished with adequate clearance, stop, and tail lights, directional signals and reflectors with proper conspicuity striping XX YES \_\_\_ NO

X7.12.2 Are all lights LED type XX YES \_\_\_ NO

X7.13 Is upper fifth wheel plate adequate in size for coupling with a standard size fifth wheel and/or full oscillation fifth wheel. XX YES \_\_\_ NO

X7.14 Is kingpin .30 inch setting, bolted assembly, with standard upper coupler height of 49 inches to 50 inches XX YES \_\_\_ NO

X7.15 Suspension:

X7.15.1 Suspension: AANT 230 HP  
122 inch spread tandem XX YES \_\_\_ NO

X7.15.2 Capacity of rear suspension: 44,000 lbs.

X7.15.3 Landing Gear: 50,000 lift capacity with 2 speed road side crank

X7.16 Other Standard Features not addressed: \_\_\_\_\_

X7.17 Will unit be delivered to WV DOH with all manufacturers recommended safety related decals and safety features intact XX YES \_\_\_ NO

X7.18 Will you install at your facility mudflaps furnished by WVDOH  YES  NO

X7.19 Paint: Describe Steel Parts Painted Black, properly cleaned,

Two Part Epoxy Primer with Acrylic Enamel.

X7.20 Will unit comply with all OSHA requirements?  YES  NO

X7.21 Will unit comply with all advertising guidelines?  YES  NO

WV-96  
Rev. 5/94

AGREEMENT ADDENDUM

In the event of conflict between this addendum and the agreement, this addendum shall control:

1. **ARBITRATION** - Any references to arbitration contained in the agreement are hereby deleted. Disputes arising out of the agreement shall be presented to the West Virginia Court of Claims.
2. **HOLD HARMLESS** - Any clause requiring the Agency to indemnify or hold harmless any party is hereby deleted in its entirety.
3. **GOVERNING LAW** - The agreement shall be governed by the laws of the State of West Virginia. This provision replaces any references to any other State's governing law.
4. **TAXES** - Provisions in the agreement requiring the Agency to pay taxes are deleted. As a State entity, the Agency is exempt from Federal, State, and local taxes and will not pay taxes for any Vendor including individuals, nor will the Agency file any tax returns or reports on behalf of Vendor or any other party.
5. **PAYMENT** - Any references to prepayment are deleted. Payment will be in arrears.
6. **INTEREST** - Should the agreement include a provision for interest on late payments, the Agency agrees to pay the maximum legal rate under West Virginia law. All other references to interest or late charges are deleted.
7. **RECOUPMENT** - Any language in the agreement waiving the Agency's right to set-off, counterclaim, recoupment, or other defense is hereby deleted.
8. **FISCAL YEAR FUNDING** - Service performed under the agreement may be continued in succeeding fiscal years for the term of the agreement, contingent upon funds being appropriated by the Legislature or otherwise being available for this service. In the event funds are not appropriated or otherwise available for this service, the agreement shall terminate without penalty on June 30. After that date, the agreement becomes of no effect and is null and void. However, the Agency agrees to use its best efforts to have the amounts contemplated under the agreement included in its budget. Non-appropriation or non-funding shall not be considered an event of default.
9. **STATUTE OF LIMITATION** - Any clauses limiting the time in which the Agency may bring suit against the Vendor, lessor, individual, or any other party are deleted.
10. **SIMILAR SERVICES** - Any provisions limiting the Agency's right to obtain similar services or equipment in the event of default or non-funding during the term of the agreement are hereby deleted.
11. **ATTORNEY FEES** - The Agency recognizes an obligation to pay attorney's fees or costs only when assessed by a court of competent jurisdiction. Any other provision is invalid and considered null and void.
12. **ASSIGNMENT** - Notwithstanding any clause to the contrary, the Agency reserves the right to assign the agreement to another State of West Virginia agency, board or commission upon thirty (30) days written notice to the Vendor and Vendor shall obtain the written consent of Agency prior to assigning the agreement.
13. **LIMITATION OF LIABILITY** - The Agency, as a State entity, cannot agree to assume the potential liability of a Vendor. Accordingly, any provision limiting the Vendor's liability for direct damages or limiting the Vendor's liability under a warranty to a certain dollar amount or to the amount of the agreement is hereby deleted. In addition, any limitation is null and void to the extent that it precludes any action for injury to persons or for damages to personal property.
14. **RIGHT TO TERMINATE** - Agency shall have the right to terminate the agreement upon thirty (30) days written notice to Vendor.
15. **TERMINATION CHARGES** - Any provision requiring the Agency to pay a fixed amount or liquidated damages upon termination of the agreement is hereby deleted. The Agency may only agree to reimburse a Vendor for actual costs incurred or losses sustained during the current fiscal year due to wrongful termination by the Agency prior to the end of any current agreement term.
16. **RENEWAL** - Any reference to automatic renewal is hereby deleted. The agreement may be renewed only upon mutual written agreement of the parties.
17. **INSURANCE** - Any provision requiring the Agency to insure equipment or property of any kind and name the Vendor as beneficiary or as an additional insured is hereby deleted.
18. **RIGHT TO NOTICE** - Any provision for repossession of equipment without notice is hereby deleted. However, the Agency does recognize a right of repossession with notice.
19. **ACCELERATION** - Any reference to acceleration of payments in the event of default or non-funding is hereby deleted.
20. **AMENDMENTS** - All amendments, modifications, alterations or changes to the agreement shall be in writing and signed by both parties. No amendment, modification, alteration or change may be made to this addendum without the express written approval of the Purchasing Division and the Attorney General.

ACCEPTED BY:  
STATE OF WEST VIRGINIA

VENDOR

Spending Unit: \_\_\_\_\_

Company Name: Benson Manufacturing

Signed: \_\_\_\_\_

Signed: 

Title: \_\_\_\_\_

Title: Municipal Sales

Date: \_\_\_\_\_

Date: 12/22/2006

# A F F I D A V I T

**West Virginia Code §5A-3-10a states:**

No contract or renewal of any contract may be awarded by the state or any of its political subdivisions to any vendor or prospective vendor when the vendor or prospective vendor or a related party to the vendor or prospective vendor is a debtor and the debt owned is an amount greater than one thousand dollars in the aggregate

**DEFINITIONS:**

"Debt" means any assessment, premium, penalty, fine, tax or other amount of money owed to the state or any of its political subdivisions because of a judgment, fine, permit violation, license assessment, defaulted workers' compensation premium, penalty or other assessment presently delinquent or due and required to be paid to the state or any of its political subdivisions, including any interest or additional penalties accrued thereon.

"Debtor" means any individual, corporation, partnership, association, limited liability company or any other form or business association owing a debt to the state or any of its political subdivisions. "Political subdivision" means any county commission; municipality; county board of education; any instrumentality established by a county or municipality; any separate corporation or instrumentality established by one or more counties or municipalities, as permitted by law; or any public body charged by law with the performance of a government function or whose jurisdiction is coextensive with one or more counties or municipalities. "Related party" means a party, whether an individual, corporation, partnership, association, limited liability company or any other form or business association or other entity whatsoever, related to any vendor by blood, marriage, ownership or contract through which the party has a relationship of ownership or other interest with the vendor so that the party will actually or by effect receive or control a portion of the benefit, profit or other consideration from performance of a vendor contract with the party receiving an amount that meets or exceed five percent of the total contract amount.

**EXCEPTION:**

The prohibition of this section does not apply where a vendor has contested any tax administered pursuant to chapter eleven of this code, workers' compensation premium, permit fee or environmental fee or assessment and the matter has not become final or where the vendor has entered into a payment plan or agreement and the vendor is not in default of any of the provisions of such plan or agreement.

**LICENSING:**

Vendors must be licensed and in good standing in accordance with any and all state and local laws and requirements by any state or local agency of West Virginia, including, but not limited to, the West Virginia Secretary of State's Office, the West Virginia Tax Department, West Virginia Insurance Commission, or any other state agencies or political subdivision. Furthermore, the vendor must provide all necessary releases to obtain information to enable the Director or spending unit to verify that the vendor is licensed and in good standing with the above entities.

**CONFIDENTIALITY:**

The vendor agrees that he or she will not disclose to anyone, directly or indirectly, any such personally identifiable information or other confidential information gained from the agency, unless the individual who is the subject of the information consents to the disclosure in writing or the disclosure is made pursuant to the agency's policies, procedures and rules. Vendors should visit [www.state.wv.us/admin/purchase/privacy](http://www.state.wv.us/admin/purchase/privacy) for the Notice of Agency Confidentiality Policies.

Under penalty of law for false swearing (West Virginia Code, §61-5-3), it is hereby certified that the vendor acknowledges the information in this said affidavit and are in compliance with the requirements as stated.

Vendor's Name: Benson Manufacturing Inc.

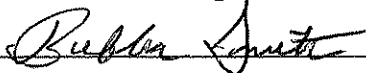
Authorized Signature:  Date: 12/22/06



State of West Virginia  
 Department of Administration  
 Purchasing Division  
 2019 Washington Street East  
 Post Office Box 50130  
 Charleston, WV 25305-0130

# Request for Quotation

RFQ NUMBER	707EC012
------------	----------

PAGE	1
------	---

ADDRESS CORRESPONDENCE TO ATTENTION OF:	JOHN JOHNSTON 304-558-2402
---	-------------------------------

\*709042146 304-489-9020  
 BENSON MANUFACTURING INC  
 I-77 & RT 14 SOUTH PO BOX 970  
 MINERAL WELLS WV 26150

VENDOR

SHIP TO

DIVISION OF HIGHWAYS  
 EQUIPMENT DIVISION  
 ROUTE 33  
 BRUSHY FORK ROAD  
 BUCKHANNON, WV  
 26201 304-472-1750

DATE PRINTED 12/18/2006	TERMS OF SALE	SHIP VIA	F.O.B.	FREIGHT TERMS
BID OPENING DATE: 12/27/2006		BID OPENING TIME: 01.30PM		

LINE	QUANTITY	UGP	CAT. NO.	ITEM NUMBER	UNIT PRICE	AMOUNT
0001	1	EA		070-66		
ADDENDUM NO. 1 CHANGES TO THE SPECIFICATIONS. ITEM 7.11.6 READS: ABS SYSTEM SHALL BE 452M MERITOR/WABCO OR EQUAL. TO READ: ABS SYSTEM SHALL BE 45TM MERITOR/WABCO OR EQUAL. BID OPENING DATE AND TIME REMAINS THE SAME. NO OTHER CHANGES.						
***** THIS IS THE END OF RFQ 707EC012 ***** TOTAL:						\$25,395

SIGNATURE <i>Bubba Smith</i>		TELEPHONE	DATE
TITLE	FERN	ADDRESS CHANGES TO BE NOTED ABOVE	

WHEN RESPONDING TO RFQ, INSERT NAME AND ADDRESS IN SPACE ABOVE LABELED 'VENDOR'



State of West Virginia  
 Department of Administration  
 Purchasing Division  
 2019 Washington Street East  
 Post Office Box 50130  
 Charleston, WV 25305-0130

# Request for Quotation

RFQ NUMBER
707EC012

PAGE
1

ADDRESS CORRESPONDENCE TO ATTENTION OF:
JOHN JOHNSTON 304-558-2402

\*709042146 304-489-9020  
 BENSON MANUFACTURING INC  
 I-77 & RT 14 SOUTH PO BOX 970  
 MINERAL WELLS WV 26150

VENDOR

SHIP TO

DIVISION OF HIGHWAYS  
 EQUIPMENT DIVISION  
 ROUTE 33  
 BRUSHY FORK ROAD  
 BUCKHANNON, WV  
 26201 304-472-1750

DATE PRINTED	TERMS OF SALE	SHIP VIA	F.O.B.	FREIGHT TERMS
12/20/2006				

BID OPENING DATE: 12/27/2006 BID OPENING TIME 01:30PM

LINE	QUANTITY	UOP	CAT. NO.	ITEM NUMBER	UNIT PRICE	AMOUNT
				ADDENDUM NO. 2		
				CHANGES TO THE SPECIFICATIONS		
				ITEM 7.11.6		
				READS: ABS SYSTEM SHALL BE 45TM MERITOR/WABCO OR EQUAL		
				TO READ: ABS SYSTEM SHALL BE 4S2M MERITOR/WABCO OR EQUAL.		
				BID OPENING DATE AND TIME REMAINS THE SAME.		
				NO OTHER CHANGES.		
0001	1	EA		070-66		
				48 FOOT ALUMINUM PLATFORM TRAILER		
***** THIS IS THE END OF RFQ 707EC012 ***** TOTAL:						\$25,395

SEE REVERSE SIDE FOR TERMS AND CONDITIONS

SIGNATURE	TELEPHONE	DATE
<i>Bubba Smith</i>		
TITLE	FEIN	ADDRESS CHANGES TO BE NOTED ABOVE

WHEN RESPONDING TO RFQ, INSERT NAME AND ADDRESS IN SPACE ABOVE LABELED 'VENDOR'

DBS PS

REQUISITION HEADER AND LINE COMMENTS

SCM

3

NEXT FUNCTION: \_\_\_\_\_ ACTION: \_\_\_\_\_  
REQUEST: \_\_\_\_\_ SAVE SHOW PAGE NO: \_\_\_\_\_

10/26/2006 10:53:46

BUY ENTITY: PUR REQUISITION NO: ~~707EC011~~ 707EC012

CATALOG NO: \_\_\_\_\_ ITEM NO: e10 BEGINNING SEQUENCE NUMBER: \_\_\_\_\_

A/B C/D	REQ. LINE	SEQ NO.	COMMENTS/SPECIFICATIONS/INSTRUCTIONS	PRINT LINE
		95	EXHIBIT 10	Y
		100		Y
		105	REQUISITION NO.: .....	Y
		110		Y
		115	ADDENDUM ACKNOWLEDGEMENT	Y
		120		Y
		125	I HEREBY ACKNOWLEDGE RECEIPT OF THE FOLLOWING CHECKED	Y
		130	ADDENDUM(S) AND HAVE MADE THE NECESSARY REVISIONS TO MY	Y
		135	PROPOSAL, PLANS AND/OR SPECIFICATION, ETC.	Y
		140		Y
		145	ADDENDUM NO.'S:	Y
		150		Y
		155	NO. 1 .OK..	Y
		160		Y
		165	NO. 2 .OK..	Y
		170		Y
		175	NO. 3 .....	Y
		180		Y
		185	NO. 4 .....	Y
		190		Y
		195	NO. 5 .....	Y
		200		Y
		205	I UNDERSTAND THAT FAILURE TO CONFIRM THE RECEIPT OF THE	Y
		210	ADDENDUM(S) MAY BE CAUSE FOR REJECTION OF BIDS	Y
		215	<i>Benson</i>	Y
		220	SIGNATURE	Y
		225	<i>Benson</i>	Y
		230	COMPANY	Y
		235	<i>12/22/06</i>	Y
		240	DATE	Y
		245		Y
		250		Y
		255		Y
		260		Y
		265		Y
		270	REV. 11/96	Y



# **H** WARRANTY TRAILER SUSPENSION SYSTEMS

SUBJECT: Comprehensive Warranty Statement  
USA and Canada

LIT NO: L583

DATE: October 2006

REVISION: H

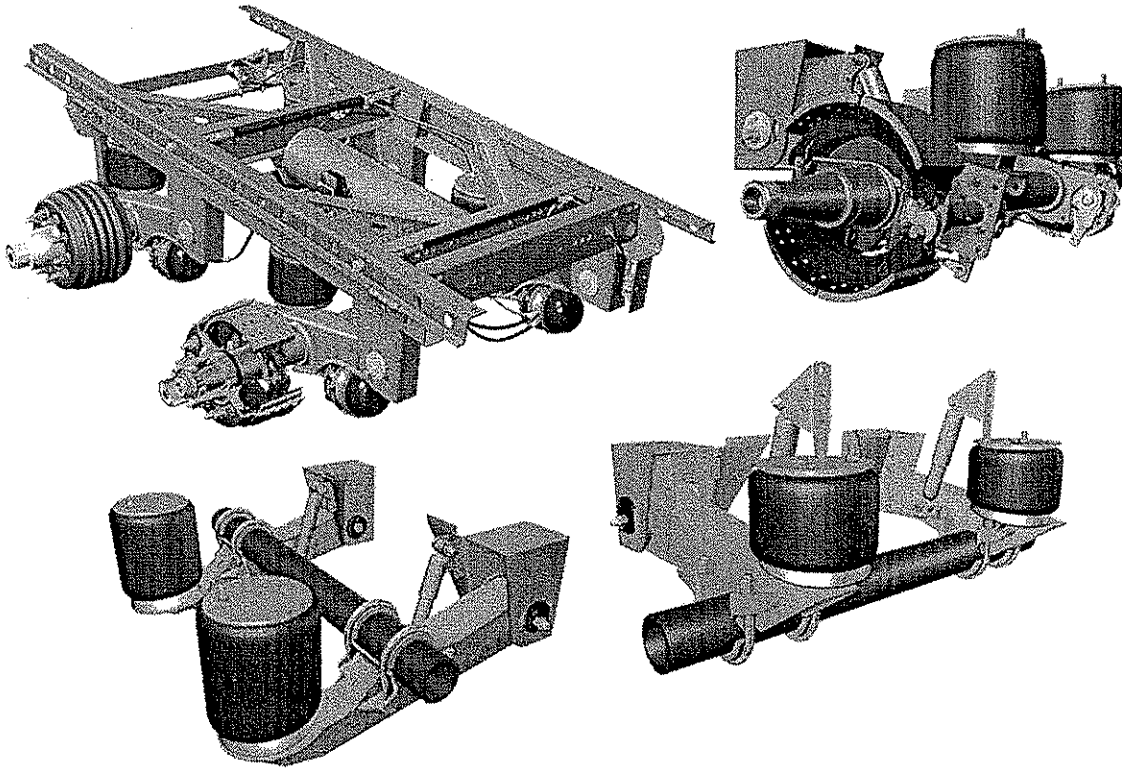

## TABLE OF CONTENTS

WARRANTY CONDITIONS . . . . .	2
COVERAGE . . . . .	2
WARRANTY CLAIM CONSIDERATIONS . . . . .	3
Filing Warranty Claims . . . . .	3
LABOR ALLOWANCES . . . . .	4
COVERAGE TABLE . . . . .	10
ADDITIONAL WARRANTY COVERAGE INFORMATION . . . . .	18



**WARRANTY CONDITIONS**

Hendrickson Trailer Suspension Systems (Hendrickson) warrants that all trailer suspensions, listed on the following pages, shall be free of defects in material or workmanship. This warranty coverage only applies to those suspensions that have been properly assembled and installed by a trailer original equipment manufacturer (OEM), properly maintained (as described in all applicable Hendrickson publications) and used in the recommended application and within the rated capacities (as described in the Hendrickson *Application Guide*, publication L707). All non-recommended suspension applications must receive written approval from Hendrickson in order to be covered under this warranty. This warranty is subject to the conditions, exclusions and limitations listed below.

- Please contact the Hendrickson technical services department to receive warranty authorizations and/or to obtain warranty claim numbers (800-455-0043 in the United States or 800-668-5360 in Canada). Note that the terms and coverages in this warranty document apply only to the United States and Canada. If you need warranty information for Mexico, contact Hendrickson Mexicana at +52 (81) 8156-1300.
- Prior to the warranty repair or replacement of suspension systems or parts (by a dealer or other service provider authorized by the OEM of the subject trailer), the warranty claim must first be approved by the Hendrickson technical services department. Trailer dealers should inspect all suspensions involved in a warranty claim and then contact Hendrickson for assistance.
- Parts to be returned under a warranty claim must be accompanied by an RGO (returned goods order), RGA (returned goods authorization) or the warranty claim number issued by the Hendrickson technical services department.
- Parts returned under a warranty claim number must be sent prepaid. Hendrickson will reimburse the customer for the freight charges if the returned parts are confirmed to be defective or non-functioning.
- Only genuine Hendrickson parts, or parts sold through Hendrickson, may be used to repair Hendrickson suspension systems. Our warranty also applies only to genuine Hendrickson parts.

- Refer to the labor allowances on pages four through seven for a listing of typical repairs. Contact the Hendrickson technical services department to discuss allowances for anything not listed.
- Hendrickson has the sole discretion and authority to approve or disapprove a warranty claim, authorize the repair or replacement of non-functioning systems and authorize the repair or replacement of parts.
- Replacement parts provided under warranty are not warranted, they simply inherit the remainder of the suspension warranty. Goodwill or giveaway (sales policy) parts provided at no charge have no warranty.

When contacting the technical services department to receive warranty authorization, costs and procedures will be determined (see labor allowance chart for a listing of typical repairs). Hendrickson will pay a specified labor allowance, determined by the Hendrickson technical services department for the authorized repair or replacement of any defective component. Hendrickson is not responsible for any additional costs that may be incurred when replacement parts or materials are not acquired through Hendrickson.

**COVERAGE**

The Hendrickson suspension warranty coverage begins when the vehicle is put into service and ends when the time period specified in the warranty-coverage table (pages 10 through 15) is reached.

The warranty shall not apply to or include any repair or replacement as a result of the following conditions:

- Accident, fire or other casualty
- Misuse or negligence including, but not limited to, overloading
- Lack of reasonable and proper maintenance
- Repairs improperly performed or replacements improperly installed
- Use of component parts, replacement or otherwise, that are not manufactured or distributed by Hendrickson
- Modifications not recommended or approved by Hendrickson (in writing)
- Uses other than those intended by Hendrickson and the trailer OEM
- Normal wear and deterioration occasioned by the use of the suspension system



- Any damage or failure caused by or otherwise attributed to any vehicle or trailer components, systems or equipment that are not manufactured or distributed by Hendrickson

The liability of Hendrickson under this warranty is limited solely to the repair or replacement of defective material or workmanship by an authorized party. Hendrickson shall not be liable for repairs performed by any unauthorized parties. This warranty does not include any expense of or related to transportation of the parts to or from the place where the repair is to be performed or compensation for inconvenience or loss of use while the suspension system is being repaired. Hendrickson shall not be liable for any expense, loss or damage (direct, incidental, consequential or exemplary — including, but not limited to, towing expenses, downtime expenses, cargo damage, incidental charges or any other losses arising in connection with the sale, use or inability to use the suspension system) resulting from the warranty-covered part found to be defective.

No expressed warranty is given by Hendrickson with respect to its suspension systems and products except as specifically set forth herein. Any warranty implied by law, including any warranty of merchantability or fitness for a particular purpose, is limited to the expressed warranty term provided in the warranty-coverage table (pages 10 through 15).

## WARRANTY CLAIM CONSIDERATIONS

- **SYSTEM PROBLEMS OR PARTS FAILURES THAT RESULT FROM IMPROPER INSTALLATION ARE THE RESPONSIBILITY OF THE INSTALLER OF THE SUSPENSION.** These are not warranted by Hendrickson.
- **THE HENDRICKSON TECHNICAL SERVICES DEPARTMENT MUST AUTHORIZE REPAIRS PRIOR TO THEM BEING PERFORMED.** When authorizing repairs or services, the warranty administrator will determine the costs and procedures (see the labor allowances on pages four through seven for a listing of typical repairs). Failure to receive Hendrickson authorization may result in partial or complete loss of warranty coverage.
- **DO NOT DESTROY THE PARTS BEING CONSIDERED FOR WARRANTY!** All parts in question must be returned to Hendrickson for evaluation. Failure to return such parts may result in partial or complete loss of warranty coverage.

- **“SHOP SUPPLY” REIMBURSEMENT MAXIMUM.** The maximum amount to be considered for miscellaneous supply, shop supply, or job supply reimbursement is 4 percent of invoiced labor charges, up to a maximum of \$20.

## FILING WARRANTY CLAIMS

1. Review warranty coverage for the component(s).

If the component complies with the stated time period for warranty coverage, continue with step two.

2. Locate, record and provide to Hendrickson the following information:
  - Hendrickson suspension model number
  - Hendrickson model serial number
  - Type of vehicle, name of vehicle manufacturer and VIN (vehicle identification number)
  - Approximate number of suspension miles
  - Model's in-service date
  - Description of the system problem and/or the part number of the non-functioning part
  - Special application approval documentation (if applicable)
3. Contact the proper authority:

- A. **IF YOU ARE AN END USER (OWNER) OR DEALER:** Report the problem to the trailer manufacturer or the suspension installer.

If the problem is not related to installation, the manufacturer or installer will contact Hendrickson to file the warranty claim.

- B. **IF YOU ARE A TRAILER MANUFACTURER:** Contact the Hendrickson Trailer technical services department at 800-455-0043 (in the United States) or at 800-668-5360 (in Canada) and provide the information recorded in step two. If operating in Mexico, please refer to Hendrickson publication L826SP, *Póliza de Garantía - México* for warranty information.

The technical services department will issue an RGO, RGA or warranty claim number for each submitted claim. All parts to be returned to Hendrickson or its vendors must be labeled with this claim number and shipped within 60 days for timely processing of the warranty claim.

# COMPREHENSIVE WARRANTY STATEMENT



4. Submit a work order job description with your RGO, RGA or warranty claim number describing what is to be repaired or replaced (refer to the standard repair times listed on pages four through seven). This work order job description should be as itemized and detailed as possible for prompt processing and maximum consideration.

## LABOR ALLOWANCES

The standard repair times listed here include but are not limited to the parts in the itemized description. It may be necessary to remove and install additional parts not included in the basic descriptions in order to complete the warranty repair.

Detailed repair descriptions must be included with the submitted warranty claim.

If a warranty claim is submitted with a repair time in excess of the following standard repair times, then a detailed description explaining the reason for the excess is required.

The following labor allowances have been based upon work conducted by various repair facilities and include technician set-up time, diagnostic time and consideration of applicable supervisory/administration requirements.

COMPONENT DESCRIPTION	TIME(HOURS)
TRI-FUNCTIONAL® Bushings Includes: • Removal and replacement of: - TRI-FUNCTIONAL Bushings* - Bushing tube spacers - Pivot connection hardware* • Axle alignment*	4.0 (per axle)
Bushing tube spacers Includes: • Removal and replacement of: - Bushing tube spacers - Pivot connection hardware* • Axle alignment*	1.5 (per axle)

COMPONENT DESCRIPTION	TIME(HOURS)
Air spring/piston Each air spring (up to three) Each additional air spring	1.0 .5
Center lift air spring	.5
Shock absorber	.5
Shock bracket (upper) Weld-on Bolt-on	1.5 1.0
Shock bracket (lower) AAL, AAEDT and AAEDL rear-mount only	1.0
Frame bracket (welded) Includes: • Removal and replacement of: - Pivot connection hardware* • Axle alignment*	4.0
Axle alignment (dual axles with QUIK-ALIGN®) • Each additional axle Includes: • Removal and replacement of: - QUIK-ALIGN pivot connection hardware*	1.0 .5
Axle alignment (dual axles with welded collars) • Each additional axle Includes: • Removal and replacement of: - Pivot connection hardware*	1.5 .8
Frame bracket (bolt-on) Includes: • Removal and replacement of: - Pivot connection hardware* • Axle alignment*	3.0
Beam and axle seat assembly for HT and T suspensions	4.0
Air reservoir	1.0

\* Installed/performed following the approved Hendrickson procedure.



# COMPREHENSIVE WARRANTY STATEMENT

COMPONENT DESCRIPTION	TIME(HOURS)	COMPONENT DESCRIPTION	TIME(HOURS)
Valves		Brake camshaft — INTRAAX® models "A" and "B" (Requires hub removal)	1.6
Quick release valve	1.0	Includes:	
Height control valve	1.0	• Removal and installation of:	
Includes:		- Tire/wheel assembly	
• Removal and installation of height control valve linkage		- Hub and drum	
• Ride height adjustment		- Slack adjuster	
Height control valve linkage	.5	• Brake adjustment	
Solenoid valve	1.0	Brake camshaft only — INTRAAX model "C" and Cam Tube System models (does not require hub removal)	1.2
Air pilot valve	1.0	Includes:	
Brake protection valve	1.0	• Removal and installation of:	
Flipper valve	1.0	- Tire/wheel assembly	
Dial-a-ride	1.0	- Brake drum	
Hand control valve	1.0	- Slack adjuster	
Manual exhaust valve	1.0	• Brake adjustment	
Pressure protection valve	1.0	Brake camshaft and cam tube assembly — INTRAAX model "C" and Cam Tube System models (does not require hub removal)	1.4
Brake chamber	.8	Includes:	
Brake hose (relay valve to brake chamber)	.5	• Removal and installation of:	
ABS wheel sensor (one)	1.0 <sup>1</sup>	- Tire/wheel assembly	
Includes:		- Brake drum	
• Removal and installation of:		• Brake adjustment	
- Tire/wheel assembly		Cam tube assembly only — Cam Tube System models only (does not require tire/wheel, drum or hub removal)	.8
- Brake drum		Includes:	
Adjust ABS wheel sensors (up to four)	.5 <sup>1</sup>	• Removal and installation of:	
ABS relay valve	1.0 <sup>1</sup>	- Slack adjuster	
ABS modulator valve	1.1 <sup>1</sup>	• Brake adjustment	
ABS electronic control unit (ECU)	1.1 <sup>1</sup>	Wheel end (complete; includes removal and installation of tire/wheel assembly)	
Slack adjuster	.7	Inner wheel seal	1.0
Brake shoes with linings (does not require hub removal)	2.5 (per axle)	Hub	1.4
Includes:		Wheel studs (up to three)	1.7
• Removal and replacement of:		Hub cap/gasket (tire/wheel removal not required)	
- Brake shoe with lining*		• Up to a quantity of two	.5
• Removal and installation of:		• Each additional hub cap / gasket	.2
- Tire/wheel assembly			
- Hub and drum			
• Brake adjustment			

<sup>1</sup> Includes troubleshooting.

\* Installed/performed following the approved Hendrickson procedure.

# COMPREHENSIVE WARRANTY STATEMENT



COMPONENT DESCRIPTION	TIME(HOURS)	COMPONENT DESCRIPTION	TIME(HOURS)
HALF-TRAAX	6.0	Does not include:	
Includes:		• Additional air reservoirs and mounting brackets	
• Removal and replacement of:		• SURELOK® trailer ride height locking system	
- Pivot connection hardware*		• Binkley Quick Release pin-pull mechanism	
• Axle alignment*		• Tire inflation systems	
• Removal and installation of:		Additional labor time is required for these items.	
- Tire/wheel assembly		K-brace reinforcement plate installation	3.0
- Hubs and drums		VANTRAAX® HKAT 50K (HKA250) only;	
- Air springs		quantity of four per slider	
- Shocks and shock mounting hardware		Slider box replacement (AAZ models)	
- Height control valve		Single	8.0
- ABS valves and sensor wiring		Tandem	12.0
- Brake chambers		Includes:	
- Stack adjusters		• Removal and replacement of:	
- S-cams		- Pivot connection hardware*	
- S-cam bearings		• Axle alignment*	
- Brake shoes with linings and hardware		• Removal and installation of:	
Under beam lift (UBL) kit		- Tire/wheel assembly	
complete installation	4.5 (per axle)	- Air springs	
UBL air spring (each)	1.0	- Shocks and shock mounting hardware	
Slider box replacement (HK/HKA models)		- Air lines	
Single (HKA models only)	8.0	- One air reservoir and mounting brackets	
Tandem	12.0	- Air valves	
Tridem (HKA models only)	16.0	- Suspensions	
Includes:		- Brake lines	
• Removal and replacement of:		- Brake valves	
- Pivot connection hardware*		- ABS valves and sensor wiring	
• Axle alignment*		- Height control valve	
• Removal and installation of:		- QUIK-DRAW slider pin-pull mechanism	
- Tire/wheel assembly		Does not include:	
- Air springs		• Additional air reservoirs and mounting brackets	
- Shocks and shock mounting hardware		• Tire inflation systems	
- Air lines		Additional labor time is required for these items.	
- One air reservoir and mounting brackets		QUIK-DRAW control valve	.5
- Air valves		QUIK-DRAW control valve knob	.2
- Suspensions		QUIK-DRAW linear actuator (HK/HKA models):	
- Brake lines		Front	.5
- Brake valves		Rear	.8
- ABS valves and sensor wiring		QUIK-DRAW air chamber actuator (AAZ models)	.8
- Height control valve			
- QUIK-DRAW® slider pin-pull mechanism			

\* Installed/performed following the approved Hendrickson procedure.



# COMPREHENSIVE WARRANTY STATEMENT

COMPONENT DESCRIPTION	TIME(HOURS)	COMPONENT DESCRIPTION	TIME(HOURS)
QUIK-DRAW® retrofit kit (HK/HKA models)	2.0	HTIS controller assembly	1.0
Includes:		HTIS system setup program	
• Removal of original pin-pull mechanism		• System learn (manual) method	.8
SURELOK® return spring	.2	• Service tool method	.5
SURELOK actuator	.5	TIREMAAX® kit complete installation	
SURELOK restraint bolt	.5	• Tandem	
Includes:		– Prepped INTRAAX axle	6.0
• Adjustment and system check		– Non-prepped INTRAAX axle	12.0
SURELOK ride height lock assembly	1.0	• Each additional axle	
Includes:		– Prepped INTRAAX axle	1.0
• Adjustment and system check		– Non-prepped INTRAAX axle	2.0
Pivot connection hardware	1.0 (per axle)	TIREMAAX fire hoses	
Includes:		(requires tee fitting guard removal)	
• Removal and replacement of:		• First wheel end (one or two hoses)	.3
– Existing pivot connection hardware*		• Each additional wheel end (per trailer)	.2
• Axle alignment*		TIREMAAX tee fitting	
HTIS kit complete installation		• Up to four (per trailer)	.5
• Tandem		• Each additional (same trailer)	.2
– Prepped INTRAAX® axle	6.0	Includes:	
– Non-prepped INTRAAX axle	12.0	• Removal and installation of:	
• Each additional axle		– Tee fitting guard (if present)	
– Prepped INTRAAX axle	1.0	TIREMAAX rotary union	
– Non-prepped INTRAAX axle	2.0	Each	.5
HTIS fire hoses		Includes:	
(requires tee fitting guard removal)		• Removal and installation of:	
• 1st pair (one or two hoses)	.3	– Hub cap	
• Each additional wheel end (per trailer)	.2	– Internal axle hose attachment	
HTIS tee fitting		• Removal and replacement of:	
• Up to four (per trailer)	.5	– Hub cap gasket	
• Each additional (same trailer)	.2	– Spindle end plug	
Includes:		– Oetiker hose clamp	
• Removal and installation of:		TIREMAAX controller assembly	1.0
– Tee fitting guard (if present)		TIREMAAX target pressure programming	
HTIS rotary union		using the hand-held programming device	
Each	.5	(does not require controller assembly removal)	.2
Includes:		Tire inflation system wiring harness	
• Removal and installation of:		(HTIS and TIREMAAX)	
– Hub cap		• Premium, ABS-ready harness	1.0
– Internal axle hose attachment		• Standard, 3-wire adapter plug	.5
• Removal and replacement of:			
– Hub cap gasket			
– Spindle end plug			
– Oetiker hose clamp			



**SUSPENSION TYPE DEFINITIONS**

The suspension type abbreviations used in the coverage table on pages 10 through 15 are defined as follows:

**Slider Suspension Systems**

**AAZ** - Any INTRAAX® suspension on a Z-rail platform slider. In cases where warranty coverage or components differ for a certain AAZ model, the specific model will be noted by one of the following descriptions: **AAZNT, AAZL.**

**HKA** - All VANTRAAX® slider systems (INTRAAX suspensions on a K-2® slider box). In cases where warranty coverage or components differ for a certain VANTRAAX model, the specific model will be noted by one of the following descriptions: **HKAT, HKAL, HKANT, HKARL.**

**HK** - HT suspensions on K-2 slider box

**HS** - HT suspensions on HS slider box

**Primary Fixed and Lifiable Suspensions**

**AA** - All INTRAAX primary suspensions. In cases where warranty coverage or components differ for a certain INTRAAX model, the specific model will be noted by one of the following descriptions: **AAL, AAT, AANT, AANLS, AAEDT, AAEDL.**

**HT** - HT Series primary suspensions

**T** - T Series primary suspensions







**COVERAGE TABLE**

The coverage periods in this table apply when the suspension has been properly assembled and installed by a trailer original equipment manufacturer (OEM), properly maintained (as described in all applicable Hendrickson publications) and used in the recommended application and within the rated capacities (as described in the Hendrickson *Application Guide*, publication L707). Coverage may differ on some items used in applications for which special written approval from Hendrickson has been granted. For more warranty coverage information, contact the Hendrickson technical services department at 800-455-0043 in the United States or at 800-668-5360 in Canada. If you need warranty information for Mexico, contact Hendrickson Mexicana at +52 (81) 8153-1300 or refer to Hendrickson publication L826SP, *Póliza de Garantía - México* for warranty information.

ITEM DESCRIPTION	SUSPENSION TYPE	PARTS	LABOR	COMMENTS (RESTRICTIONS, ETC.)
<b>SUSPENSION COMPONENTS</b>				
Axle/Trailing Arm Assembly <sup>2</sup>	AA, AAZ, HKA	5 years	1 year	
Trailing Arm-to-Axle Connection	AA, AAZ, HKA	10 years	5 years	
Frame Brackets (Hangers)	All	5 years	1 year	If used in the raw wood industry <sup>3</sup> : Parts - 3 years Labor - 1 year
Trailing Arms (Beams)	T HT	5 years	1 year	If used in the raw wood industry <sup>3</sup> : Parts - 3 years Labor - 1 year
<b>TRI-FUNCTIONAL® BUSHINGS AND BUSHING TUBE SPACERS (NOT AVAILABLE — SERVICED WITH TF II)*</b>				
TRI-FUNCTIONAL® Bushings and Bushing Tube Spacers*	T, HT, HK, HS	5 years	1 year	If used in the raw wood industry <sup>3</sup> : Parts - 3 years Labor - 1 year
<b>TRI-FUNCTIONAL II BUSHINGS AND BUSHING TUBE SPACERS*</b>				
49" Closed- Spaced Van Applications <sup>4</sup>	AAT, AAL, HT, HKAT, HKARL, HK, HS	7 years	5 years	
Vocational, Wide-Spread Van and/or Liffable Axle <sup>5</sup>	HT, AAT, AAL, AAZL, AAEDT, AAEDL	5 years	3 years	If used in the raw wood industry <sup>3</sup> : Parts - 3 years Labor - 1 year
<b>TRI-FUNCTIONAL III BUSHINGS AND BUSHING TUBE SPACERS*</b>				
49" Closed-Spaced Van Applications <sup>4</sup>	HKANT	7 years	5 years	
Vocational, Wide-Spread Van and/or Liffable Axle <sup>5</sup>	AANT, AAZNT, AANLS	5 years	3 years	

\*Effective with suspensions built and delivered after 2/1/01.

Continued on page 11

<sup>1</sup>Refer to page eight for suspension type definitions.

<sup>2</sup>Axles that are drilled for tire inflation system (Hendrickson or otherwise) that do not follow Hendrickson's recommended drilling procedures (as described in Hendrickson publications L786, *Hendrickson Tire Inflation System - Installation, Service and Troubleshooting Procedures* or L818, *TIREMAAX® Tire Inflation System - Installation, Service and Troubleshooting Procedures*) could void the axle warranty. Unrecommended drilling could cause damage to the axle or other suspension components. Refer to pages 13 through 15 for additional information.

<sup>3</sup>Hendrickson defines the raw wood industry as any forestry application that involves or includes, but is not limited to, logging or chip hauling. INTRAAX AAEDT 30K and AAEDL 30K models are recommended for these applications, and are covered by the standard INTRAAX warranty. AAT 30K and AAL 30K may also be used when written application approval is received from Hendrickson engineering, in which case the standard INTRAAX warranty shall apply. Other INTRAAX and HT models, when used in accordance with Hendrickson publication L707, *Application Guide*, will be covered under the reduced warranty terms noted here. Refer to page 16 for further raw wood warranty information.

<sup>4</sup>For highway use only in single-axle or closed-spaced (for example, 49 inches) tandem applications on van- and reefer-type trailers.

<sup>5</sup>For all vocational trailers, specialty or spread-axle vans and reefers and liffable axle suspensions.



COVERAGE TABLE (CONTINUED)

ITEM DESCRIPTION	SUSPENSION TYPE	PARTS	LABOR	COMMENTS (RESTRICTIONS, ETC.)
<b>SUSPENSION COMPONENTS (CONTINUED)</b>				
QUIK-ALIGN® Pivot Assembly	All	1 year	1 year	For non pre-aligned systems, proper trailer OEM installation is required <sup>2</sup>
Air Springs	All	2 years	1 year	
Air and Electronic Controls	All	1 year	1 year	
Shock Absorbers	All	2 years	2 years	If used in the raw wood industry <sup>3</sup> : Parts - 2 years Labor - 1 year
<b>SLIDER ASSEMBLY</b>				
Slider Box Assembly	All	5 years	1 year	Includes slider pins and slider pin return springs
<b>ALL OTHER SUSPENSION AND SLIDER COMPONENTS<sup>4</sup></b>				
Suspension and Slider Components	All	1 year	1 year	Includes all other mechanical pin release/activation components
<b>AFTERMARKET PARTS</b>				
Genuine Hendrickson Replacement Parts (not installed as part of a warranty repair)	All	1 year	N/A	Requires original purchase or installation invoice
<b>QUIK-DRAW® SLIDER PIN-PULL MECHANISMS</b>				
Air Control Components	HK/HKA/AAZ	1 year	1 year	
Air Actuator	HK/HKA/AAZ	3 years	3 years	
<b>SURELOK® TRAILER RIDE HEIGHT LOCK</b>				
Mechanical Components (Factory Installed Only)	HK/HKA	3 years	1 year	
Air Control Components (Factory Installed Only)	HK/HKA	1 year	1 year	
Retrofit Kits (Not Factory-Installed Components)	HK/HKA	1 year	N/A	Requires verification of kit number and includes retrofit air control kit
<b>MAXILOK® TRAILER-SUPPORT SYSTEM</b>				
Mechanical Components	HT250U/HT200UM	3 years	1 year	
Air Control Components	HT250U/HT200UM	1 year	1 year	
<b>UNDER BEAM LIFT (UBL) LIFT AXLE SYSTEM</b>				
All Components	All applicable	1 year	1 year	Proper OEM installation required

Continued on page 12

<sup>1</sup>Refer to page eight for suspension type definitions.

<sup>2</sup>For non pre-aligned suspension systems, the installation and final assembly of the suspension pivot connection is performed by the respective trailer OEM. Refer to pages 16 and 17 for further information.

<sup>3</sup>Hendrickson defines the raw wood industry as any forestry application that involves or includes, but is not limited to, logging or chip hauling. INTRAAX AAEDT 30K and AAEDL 30K models are recommended for these applications, and are covered by the standard INTRAAX warranty. AAT 30K and AAL 30K may also be used when written application approval is received from Hendrickson engineering, in which case the standard INTRAAX warranty shall apply. Other INTRAAX and HT models, when used in accordance with Hendrickson publication L707, *Application Guide*, will be covered under the reduced warranty terms noted here. Refer to page 16 for further raw wood warranty information.

<sup>4</sup>Includes suspension and slider components that are A) not specifically covered in this table and B) manufactured and distributed by and for Hendrickson.



COVERAGE TABLE (CONTINUED)

ITEM DESCRIPTION	SUSPENSION TYPE	PARTS	LABOR	COMMENTS (RESTRICTIONS, ETC.)
<b>DRUM BRAKE COMPONENTS</b>				
Brake Linings and All Brake Related Hardware	AA/HKA/AAZ	1 year	1 year	Excludes all normal wear
Brake Camshaft	AA/HKA/AAZ	3 years	1 year	
Cam Tube (Off-Highway Applications)	AA	3 years	1 year	Excludes brake camshaft wear
Cam Tube (Highway Applications)	AA/HKA/AAZ	3 years	3 years	
Automatic Slack Adjusters	AA/HKA/AAZ	5 years <sup>2</sup>	1 year	Off-highway - 1 year parts.  Coverage limited to components sold and installed by Hendrickson Trailer Suspension Systems, but not included in a wheel-end package (excludes normal wear on brake drums)
Brake Chamber (Premium 30/30)	AA/HKA/AAZ	6 years <sup>2</sup>	1 year	
Brake Chamber (All Others)	AA/HKA/AAZ	3 years <sup>2</sup>	1 year	
Brake Drums (Cast) - Not Overheated	AA/HKA/AAZ	1 year	1 year	
Brake Drums (Centrifuse)	AA/HKA/AAZ	1 year	N/A	
<b>AIR DISC BRAKE COMPONENTS</b>				
Brake Pads and All Brake Related Hardware	AA/HKA/AAZ	1 year	1 year	Excludes all normal wear
Caliper	AA/HKA/AAZ	1 year	1 year	
Rotors	AA/HKA/AAZ	1 year	1 year	
Brake Chamber	AA/HKA/AAZ	1 year <sup>2</sup>	1 year	

Continued on page 13

<sup>1</sup> Refer to page eight for suspension type definitions.

<sup>2</sup> The suppliers of these non-Hendrickson components may offer warranty coverage beyond the terms listed here. Contact the appropriate supplier for complete details.



COVERAGE TABLE (CONTINUED)

ITEM DESCRIPTION	SUSPENSION TYPE	PARTS	LABOR	COMMENTS (RESTRICTIONS, ETC.)
<b>WHEEL-END PACKAGES</b>				
Hub Assembly, Standard Service	AA/HKA/AAZ	1 year	1 year	Coverage limited to components sold and installed by Hendrickson Trailer Suspension Systems
Hub Assembly, Extended Service (ConMet PreSet)	AA/HKA/AAZ	5 years	5 years	
Hub Assembly, Extended Service (HVS™) <sup>2</sup>	AA/HKA/AAZ	3 years	3 years	
Hub Assembly, Extended Service (HLS™) <sup>3</sup>	AA/HKA/AAZ	5 years	5 years	
Hub Assembly, Extended Service (HUS®) <sup>4</sup>	AA/HKA/AAZ	7 years	7 years	
Hub Assembly, Extended Service (Stemco Platinum Performance System) <sup>5</sup>	AA/HKA/AAZ	3 years	1 year	
Hub Assembly, Extended Service (Stemco Advantage System) <sup>5</sup>	AA/HKA/AAZ	5 years	1 year	
Hub Caps and Gaskets	AA/HKA/AAZ	1 year	1 year	
Oil Seals	AA/HKA/AAZ	1 year	1 year	
Wheel Bearings	AA/HKA/AAZ	1 year	1 year	
Axle Nuts	AA/HKA/AAZ	1 year	N/A	

Continued on page 14

<sup>1</sup> Refer to page eight for suspension type definitions.

<sup>2</sup> The three year parts and labor warranty terms apply to all on-highway applications. To be eligible for warranty coverage in any off-highway application, HVS™ hub assemblies must be configured with HP spindles and Hendrickson dust shields. When properly configured, the warranty terms are one year parts and labor.

<sup>3</sup> The five year parts and labor warranty terms apply to all on-highway applications. To be eligible for warranty coverage in any off-highway application, HLS™ hub assemblies must be configured with HP spindles and Hendrickson dust shields. When properly configured, the warranty terms are three years parts and labor (all off-highway applications except raw wood industry) or three years parts one year labor (raw wood industry applications). Refer to page 16 for further raw wood warranty information.

<sup>4</sup> These warranty terms cover units sold in North America for 23,000 pound gross axle weight rating line-haul service applications including auto-haulers, vans, reefers, flatbeds and tank trailers. Coverage may differ in some applications for which special written approval was granted. This warranty does not cover an HUS wheel end which was damaged as a result of improper modification or repair, an accident or failure to adhere to required inspection procedure guidelines.

<sup>5</sup> Hendrickson no longer offers these Extended Service hub assemblies but will honor valid warranty claims submitted on Extended Service hub assemblies delivered prior to 7/1/06.



COVERAGE TABLE (CONTINUED)

ITEM DESCRIPTION	SUSPENSION TYPE <sup>1</sup>	PARTS	LABOR	COMMENTS (RESTRICTIONS, ETC.)
<b>TIREMAAX® TIRE INFLATION SYSTEM</b>				
<b>HENDRICKSON-INSTALLED TIREMAAX WITH HENDRICKSON-INSTALLED READY-TO-ROLL® WHEEL ENDS<sup>2</sup>:</b>				
Standard Service Hub Assembly	AA/HKA/AAZ	3 years	3 years	All internal TIREMAAX axle components installed and assembled by Hendrickson
ConMet PreSet Hub Assembly	AA/HKA/AAZ	5 years	3 years	Some TIREMAAX axle components installed by Hendrickson — the trailer OEM completes the installation of remaining HTIS components  Warranty terms do not include competitor tire inflation system components
HLS™ (Hendrickson Long-life System) Hub Assembly	AA/HKA/AAZ	5 years	3 years	
HUS® Hub Assembly	AA/HKA/AAZ	7 years	3 years	
<b>HENDRICKSON-PREPARED TIREMAAX AXLES WITHOUT WHEEL ENDS<sup>2</sup>:</b>				
Axle Hose, Rotary Union and Hubcap	AA/HKA/AAZ	3 years <sup>2</sup>	3 years <sup>3,*</sup>	Some TIREMAAX axle components installed by Hendrickson — the trailer OEM completes the installation of remaining purchased TIREMAAX components  *Labor coverage applies only to Hendrickson installed components (including but not limited to axle vent line, axle hoses, spindle plugs, air control lines and INTRAAX® beam grommets)
<b>TIREMAAX ELECTRONIC COMPONENTS:</b>				
Controller Assembly	AA/HKA/AAZ	3 years	3 years	Installation must be per installation recommendations
Wiring Harness	AA/HKA/AAZ	3 years	1 year	
<b>TIREMAAX EXTERNAL WHEEL-END COMPONENTS:</b>				
Tire Hoses and Tee Fittings	AA/HKA/AAZ	1 year	1 year	
<b>TIREMAAX AFTERMARKET RETROFIT KIT (AXLE NOT HTIS-PREPARED BY HENDRICKSON)<sup>4</sup>:</b>				
All Kit Components	AA/HKA/AAZ	1 year	N/A	

Continued on page 15

<sup>1</sup>Refer to page eight for suspension type definitions.

<sup>2</sup>Includes all internal wheel-end / axle components, including hub cap, rotary union and tubing.

<sup>3</sup>Competitor tire inflation systems are not covered by Hendrickson warranty terms. Contact the respective tire inflation system manufacturer for warranty coverage of competitor make and model.

<sup>4</sup>Axles that are drilled for tire inflation system (Hendrickson or otherwise) that do not follow Hendrickson's recommended drilling procedures (as described in Hendrickson publications L786, *Hendrickson Tire Inflation System - Installation, Service and Troubleshooting Procedures* or L818, *TIREMAAX® Tire Inflation System - Installation, Service and Troubleshooting Procedures*) could void the axle warranty. Unrecommended drilling could cause damage to the axle or other suspension components.



COVERAGE TABLE (CONTINUED)

ITEM DESCRIPTION	SUSPENSION TYPE	PARTS	LABOR	COMMENTS (RESTRICTIONS, ETC.)
<b>HTIS (HENDRICKSON TIRE INFLATION SYSTEM)</b>				
<b>HENDRICKSON-INSTALLED HTIS WITH HENDRICKSON-INSTALLED READY-TO-ROLL® WHEEL ENDS<sup>2</sup>:</b>				
Hub Assembly Standard Service	AA/HKA/AAZ	3 years	3 years	All internal HTIS axle components installed and assembled by Hendrickson  Some HTIS axle components installed by Hendrickson — the trailer OEM completes the installation of remaining HTIS components  Warranty terms do not include competitor tire inflation system components
ConMet PreSet Hub Assembly	AA/HKA/AAZ	5 years	3 years	
HLS™ (Hendrickson Long-life System) Hub Assembly	AA/HKA/AAZ	5 years	3 years	
HUS® Hub Assembly	AA/HKA/AAZ	5 years	3 years	
<b>HENDRICKSON-PREPARED HTIS AXLES WITHOUT WHEEL ENDS<sup>2</sup>:</b>				
Axle Hose, Rotary Union and Hubcap	AA/HKA/AAZ	3 years <sup>2</sup>	3 years <sup>3,*</sup>	Some HTIS axle components installed by Hendrickson — the trailer OEM completes the installation of remaining purchased HTIS components  *Labor coverage applies only to Hendrickson installed components (including but not limited to axle vent line, axle hoses, spindle plugs, air control lines and INTRAAX® beam grommets)
<b>HTIS ELECTRONIC COMPONENTS:</b>				
Controller Assembly	AA/HKA/AAZ	3 years	1 year	Installation must be per installation recommendations
Wiring Harness	AA/HKA/AAZ	3 years	1 year	
<b>HTIS EXTERNAL WHEEL-END COMPONENTS:</b>				
Tire Hoses	AA/HKA/AAZ	1 year	1 year	

Continued on page 16

<sup>1</sup>Refer to page eight for suspension type definitions.

<sup>2</sup>Includes all internal wheel-end / axle components, including hub cap, rotary union and tubing.

<sup>3</sup>Competitor tire inflation systems are not covered by Hendrickson warranty terms. Contact the respective tire inflation system manufacturer for warranty coverage of competitor make and model.



COVERAGE TABLE (CONTINUED)

ITEM DESCRIPTION	SUSPENSION TYPE	PARTS	LABOR	COMMENTS (RESTRICTIONS, ETC.)
<b>COMPETITOR TIRE INFLATION SYSTEM</b>				
<b>HENDRICKSON-PREPARED AXLES WITHOUT WHEEL ENDS:</b>				
N/A	AA/HKA/AAZ	N/A	N/A	Hendrickson does not provide warranty coverage for the installation, performance or components of a competitor brand tire inflation system installed on a Hendrickson suspension. Any consequential damages to the Hendrickson suspension resulting from a failure to the competitor brand tire inflation system or components, whether installed by the OEM, repair facility or end-user customer, should be directed to the respective tire inflation system manufacturer for warranty coverage.
<b>HENDRICKSON AXLES NOT PREPARED FOR TIRE INFLATION SYSTEMS<sup>2</sup>:</b>				
N/A	AA/HKA/AAZ	N/A	N/A	Hendrickson does not provide warranty coverage for the installation, performance or components of a competitor brand tire inflation system installed on a Hendrickson suspension. Any consequential damages to the Hendrickson suspension resulting from a failure to the competitor brand tire inflation system or components, whether installed by the OEM, repair facility or end-user customer, should be directed to the respective tire inflation system manufacturer for warranty coverage.

<sup>1</sup>Refer to page eight for suspension type definitions.

<sup>2</sup>Axles that are drilled for tire inflation system (Hendrickson or otherwise) that do not follow Hendrickson's recommended drilling procedures (as described in Hendrickson publications L786, *Hendrickson Tire Inflation System - Installation, Service and Troubleshooting Procedures* or L818, *TIREMAAX® Tire Inflation System - Installation, Service and Troubleshooting Procedures*) could void the axle warranty. Unrecommended drilling could cause damage to the axle or other suspension components.





## ADDITIONAL WARRANTY COVERAGE INFORMATION

### RAW WOOD PRODUCT APPLICATIONS

Hendrickson Trailer Suspension Systems defines the raw wood industry as any forestry application that involves or includes, but is not limited to, logging or chip hauling.

Severe and highly unpredictable operating conditions are often encountered in the raw wood product industry. Such rugged applications can cause accelerated wear, deterioration and other problems in suspension systems. For this reason, warranty coverage on certain suspension components used in the raw wood industry differs from the standard warranty coverage on the same components used in less-severe applications.

All INTRAAX® AA 30K models carry the standard INTRAAX warranty (described in the coverage tables on pages 10 through 15) regardless of application. However, written application approval from Hendrickson is required for warranty coverage on INTRAAX AAL 30K and AAT 30K models when used in raw wood product applications. Warranty coverage is not limited for INTRAAX AA 30K models in raw wood product applications when this written application approval is given.

The warranty period for all other suspension components used in raw wood product applications will be up to three years for parts unless otherwise noted (see coverage tables on pages 10 through 15), and one year for labor.

This warranty coverage only affects trailers built on or after November 1, 1999, that operate in the raw wood product industry.

The warranty periods in the coverage table on pages 10 through 15 apply when the suspension has been properly assembled and installed by a trailer original equipment manufacturer (OEM), properly maintained (as described in all applicable Hendrickson publications), and used in the recommended application and within the rated capacities (as described in the Hendrickson *Application Guide*, publication L707). Coverage may differ on some items used in applications for which special written approval from Hendrickson has been granted. If you have any questions about the information contained herein, please contact the Hendrickson Trailer Suspension Systems technical service department at 800-455-0043 in the United States or 800-668-5360 in Canada.

### QUIK-ALIGN® PIVOT ASSEMBLY

Original equipment manufacturers (OEMs) have the option of ordering Hendrickson suspensions in one of two states: pre-aligned (available only on VANTRAAX® slider suspension systems) or standard (non pre-aligned - available on all Hendrickson suspension systems). In either state, the pivot connection is warranted for one year parts and labor. The difference is in application and is as follows:

Hendrickson's pre-aligned VANTRAAX slider suspension system pivot connection warranty applies to *all* QUIK-ALIGN® pivot assemblies since installation and final assembly of the pivot connection is performed by Hendrickson.

Hendrickson's standard (non pre-aligned) pivot connection warranty coverage applies only to QUIK-ALIGN pivot assemblies where proper installation and final assembly were performed. The installation and final assembly of the suspension pivot connection is performed by the respective trailer OEM. Proper installation includes, but is not limited to, the use and removal of the Torx® head of the pivot bolt to ensure proper pivot assembly torque along with the proper mounting of the alignment washers/collars (refer to Hendrickson publications L341, *INTRAAX® Installation Procedures*; L577, *HT/HS/HK Installation Procedures*, and L579, *Alignment Procedures*, for additional assembly requirements). Pivot assembly components must be available for review for warranty consideration. Pivot assemblies that are missing the plastic band, or other reuse indicator, on the pivot bolt hardware are not covered.



### **PRE-ALIGNED VANTRAAX® WARRANTY STATEMENT**

Pre-aligned VANTRAAX slider systems are built on precision fixtures and feature axles that are perpendicular to the slider box and parallel to each other. Documented measurement data confirms alignment and is shipped with each VANTRAAX system built with this option.

The trailer OEM is responsible for the total trailer alignment and all facets of construction required to accommodate the slider suspension system, such as trailer frame construction, proper placement of the kingpin, proper body rail installation and proper body rail spacing. Hendrickson provides body rail installation and spacing recommendations in publication L341, *Installation Procedures*, and in various installation drawings.

Hendrickson does not recommend additional alignment adjustments by the dealer or distributor prior to delivery to the final customer (i.e., fleet, owner operator) and will not reimburse for any related parts or labor expenses from such additional adjustments. Hendrickson warrants the perpendicularity and parallelism of the axles relative to the slider box itself, based on established Hendrickson specifications, only until delivery of the pre-aligned VANTRAAX slider suspension system to the trailer OEM.

If a performance concern is expressed by the customer regarding a pre-aligned VANTRAAX slider system, the customer or trailer OEM dealer should contact the Hendrickson technical service department at 800 455-0043 in the United States (or fax to 330 489-0494) or 800 668-5360 in Canada prior to performing any adjustments or repairs. Hendrickson will guide and provide assistance to the customer, dealer and/or repair facility through validation checks and will provide corrective actions as necessary.

### **AIR DISC BRAKE WARRANTY STATEMENT**

Hendrickson offers air disc brakes only in combination with our standard service wheel-end package. Air disc brake packages installed by Hendrickson will carry a limited one-year parts and labor warranty, excluding all normal wear.

Hendrickson publication L924 only addresses the Hendrickson warranty position on air disc brakes combined with extended service wheel-ends shipped prior to September 1, 2006.

---

[www.hendrickson-intl.com](http://www.hendrickson-intl.com)



Trailer Suspension Systems  
250 Chrysler Drive, Unit #3  
Brampton, ON Canada L6S 6B6  
905.789.1030  
Fax 905.789.1033

Trailer Suspension Systems 866.RIDEAIR (743.3247)  
2070 Industrial Place SE 330.489.0045  
Canton, OH 44707-2641 USA Fax 800.696.4416

Trailer Suspension Systems  
Av. Industria Automotriz #200  
Parque Industrial Sierra Aeropuerto  
Apodaca, N.L., México C.P. 66600  
(52) 81 8288 1300  
Fax (52) 81 8288 1301

# Enhanced Easy-Stop™ Trailer ABS

**MERITOR WABCO**

## Did You Know?

Meritor WABCO established a Trailer Products group in 1993 to focus on the needs of the North American Trailer Market. Since that time, trailer vehicle control systems has been this group's only business.

- Meritor WABCO anti-lock braking systems (ABS) are offered as standard equipment at all major trailer OEMs.
- Meritor WABCO holds a leadership position in trailer ABS and has earned a strong number one position since 1994. During this time, we've maintained fill rates of 98% or better at trailer OEMs.
- Our trailer ABS has remained cost competitive and has helped lower the true cost to OEMs and end-users through on-going innovations and increased system efficiencies.
- Meritor WABCO provides trailer ABS to cover virtually all industry applications.
- Enhanced Easy-Stop ABS went into production in 2001 — it was designed specifically for the North American Trailer Market to facilitate PowerLine Carrier (PLC) communications and advanced ABS features. We were the first trailer ABS supplier to incorporate PLC.
- Enhanced Easy-Stop ABS was designed to be a direct, cost-effective replacement for the earlier Easy-Stop system. This allowed us to provide our customers with the latest technology advancements and reduced parts inventory requirements.
- We supplied PLC adapters to other trailer ABS suppliers to help them meet the new FMVSS regulations requiring trailer ABS warning lamps in the tractor.
- Our trailer ABS can be easily diagnosed without any additional equipment, tools, or software.
- Meritor WABCO offers advanced diagnostic tools such as the Datamaster and TOOLBOX™ Software for more complete trouble shooting, repair and accessing of vehicle information.
- Our trailer ABS can be serviced cost-effectively by replacing individual components (ECU or valve) independently.
- Meritor WABCO provides industry-leading service and product support at the OEM and fleet levels.
- Complete warranty and product support for Meritor WABCO trailer ABS is available through Meritor WABCO, ArvinMeritor's North American Field Organization, Sealco Air Controls and ArvinMeritor's Commercial Vehicle Aftermarket Group.
- Meritor WABCO has the most comprehensive warranty program in the industry offering 3-Years/300,000-Miles parts and labor.
- We are the only ABS supplier that offers an additional 1-Year warranty with the use of the Meritor WABCO Control Line Air Filter on new equipment (this includes coverage of damage due to dry contaminants).
- Meritor WABCO was the first to establish communication protocols between the tractor and trailer via our InfoLink™ system.
- We were the first to provide an electronic odometer and notebook section for recording pertinent information in the ECU memory.

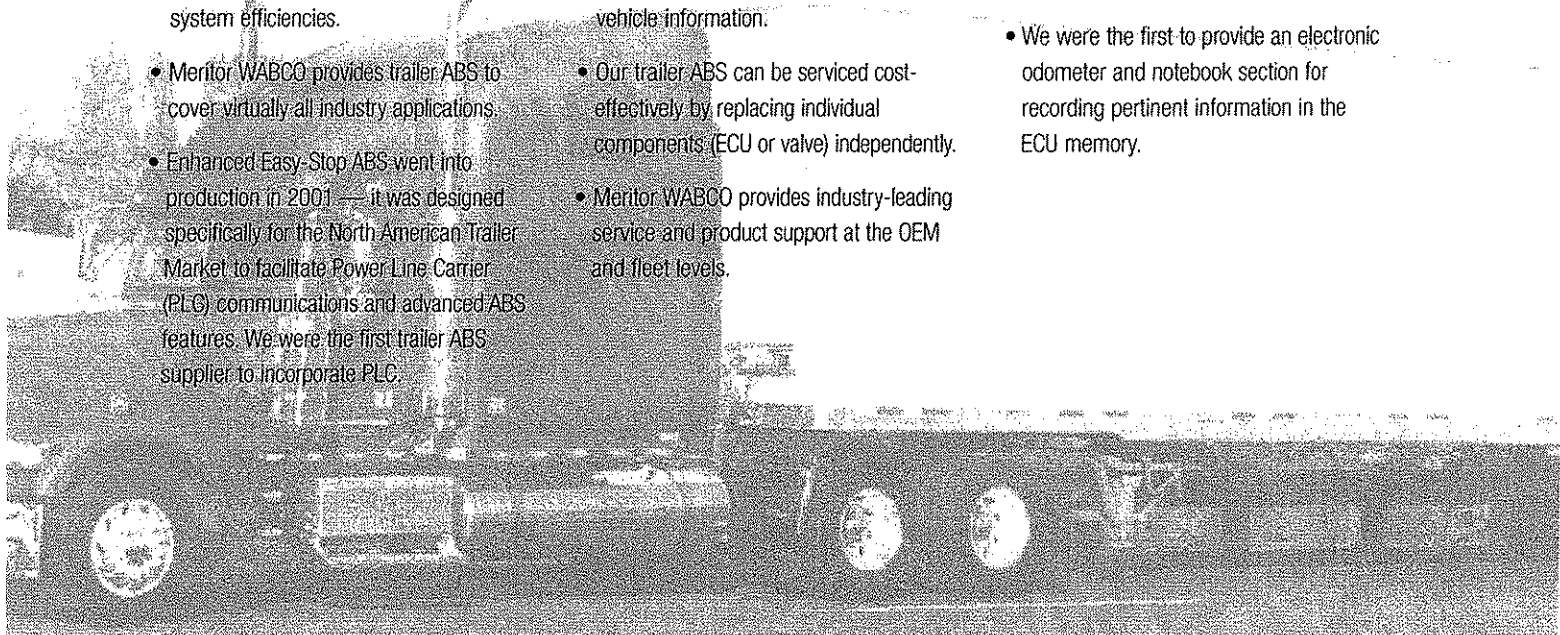

# Did You Know?

- Other manufacturer's advanced systems, new to the market today, have the same features that Meritor WABCO has been offering since 2001.
- Today, Meritor WABCO is capable of providing systems to monitor trailer functions, display trailer information in the tractor, control trailer equipment from the tractor, and communicate with third-party devices (telematics).
- Meritor WABCO is capable of communicating and displaying data from the tire inflation system to the tractor cab, without the addition of ECUs or other controls (other than a display unit in the tractor).
- We were the first to offer a Roll Stability System for North American trailers that works independently of the tractor. To date, thousands of systems have been sold.
- Meritor WABCO is jointly owned by ArvinMeritor, Inc. and WABCO Vehicle Control Systems. Each provides business capabilities that are unequaled in the trailer industry. These parent companies provide product expertise and synergies with products ranging from trailer axles, wheel ends, suspensions, tire inflation systems, disc and drum brakes, slack adjusters, and a complete range of vehicle control and air management systems.

## System configurations to suit a variety of applications

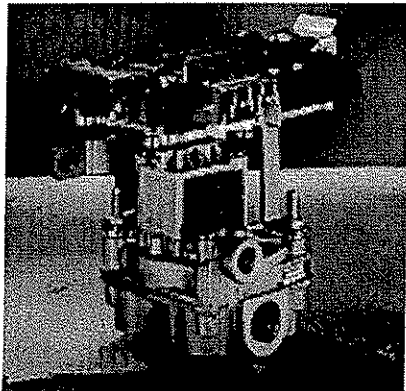

### Easy-Stop™ 2S/1M Basic

- 2-sensor/1-ABS relay valve system
- Recommended for converter dolly and semi-trailer applications
- Meets FMVSS-121 requirements related to vehicle braking control and stability
- Ability to service the ECU and ABS modulator valves individually

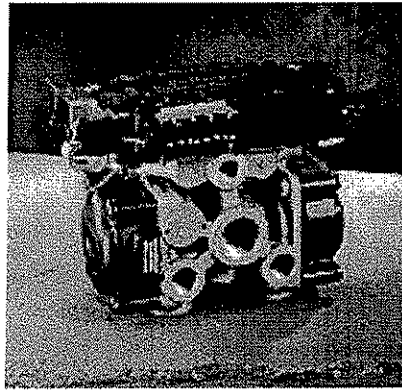

### Easy-Stop™ 2S/2M Standard

- 2-sensor/2-ABS relay valve system
- Recommended for single and tandem axle semi-trailer applications
- Improved braking control and stability
- Increased protection against tire flatspotting
- Ability to service the ECU and ABS modulator valves individually

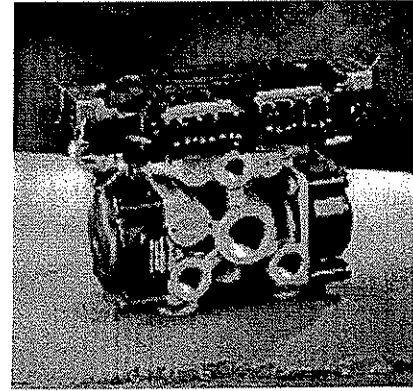

### Easy-Stop™ 2M Premium System

- Can be configured to 2S/2M, 4S/2M or 4S/3M system
- Recommended applications for this premium system include tandem axle semi-trailers, multi-axle, or full trailers
- Up to six generic input/outputs
- Optimal braking control and stability
- Optimal protection against tire flatspotting
- Ability to service the ECU and ABS modulator valves individually

Meritor WABCO Vehicle Control Systems  
2135 West Maple Road  
Troy, Michigan 48084 USA  
800-535-5560  
www.meritorwabco.com

© Copyright 2006  
ArvinMeritor, Inc.

Litho in USA

Issued 05-06  
SP-0638 (47865/11900)

**MERITOR WABCO**

**BENSON INTERNATIONAL, INC., MODEL 524 AND 724 PLATFORM TRAILER LIMITED WARRANTY (PAGE 1 OF 2)**

**SECTION 1. THE WARRANTY, EFFECTIVE JULY 1, 2003:**

A) BENSON INTERNATIONAL INC., (MANUFACTURER) WARRANTS (THE WARRANTY) TO THE ORIGINAL PURCHASER (THE PURCHASER) THAT THE STRUCTURE (MAIN BEAMS, DECK ASSEMBLY, UPPER COUPLER ASSEMBLY OR ANY OTHER STRUCTURAL MEMBER REQUIRED TO PERMANENTLY ASSEMBLE THE EQUIPMENT) OF THE BENSON MODEL 524 OR 724 ALUMINUM PLATFORM TRAILER (THE EQUIPMENT) AS IDENTIFIED IN SECTION 4, TO BE FREE FROM DEFECTS IN WORKMANSHIP AND MATERIAL OCCURRING DURING THE NORMAL USE OF AND RESULTING FROM USE WITHIN THE RATED CAPACITIES AS SHOWN IN SECTION 4, FOR A PERIOD OF FIVE (5) YEARS, PARTS AND LABOR INCLUDED, FROM THE DATE OF RETAIL DELIVERY (DELIVERY) AS SHOWN IN SECTION 4.

B) MANUFACTURER WARRANTS TO PURCHASER, 100% PARTS AND LABOR, THAT PURCHASED COMPONENTS (EXCLUSIVE OF TIRES AND WEAR AND TEAR ITEMS, EXCEPT AS PROVIDED FOR IN SECTION 1 B) 1, 2 & 3 BELOW) USED IN THE MANUFACTURE OF THE EQUIPMENT SHALL BE FREE FROM DEFECT IN WORKMANSHIP AND MATERIAL FOR ONE YEAR FROM DATE OF RETAIL DELIVERY OF THE EQUIPMENT.

1. FOR SIX MONTHS AFTER RETAIL DELIVERY: AIR BAGS, BEARINGS, DISK WHEELS, HUB CAPS, OIL SEALS, SHOCK ABSORBERS AND SPRINGS.

2. FOR THREE MONTHS AFTER RETAIL DELIVERY: BRAKE DRUMS AND BRAKE LININGS.

3. FOR FIFTEEN DAYS AFTER RETAIL DELIVERY: AXLE ALIGNMENT

C) MANUFACTURER ALSO ASSIGNS TO PURCHASER, TO THE EXTENT PERMITTED BY THE MANUFACTURER OF SUCH PURCHASED COMPONENTS, ANY WARRANTY IN EXCESS OF THAT STATED HEREIN.

D) TIRES ARE COVERED BY THE TIRE MANUFACTURER'S WARRANTY AND ANY AND ALL CLAIMS INVOLVING TIRES MUST BE HANDLED BY THE EQUIPMENT OWNER THROUGH THE TIRE MANUFACTURER'S AUTHORIZED DEALER. MANUFACTURER ASSUMES NO LIABILITY FOR IRREGULAR OR ABNORMAL TIRE WEAR OR TIRE FAILURE FROM ANY CAUSE.

**SECTION 2. THE LIMITATIONS:**

A) THIS WARRANTY IS NON-ASSIGNABLE AND IS VALID ONLY TO THE ORIGINAL PURCHASER.

B) DEFECTS IN WORKMANSHIP AND MATERIAL WILL BE REPAIRED OR REPLACED AT THE SOLE OPTION OF THE MANUFACTURER.

C) THIS WARRANTY APPLIES ONLY WHEN REPAIRS OR REPLACEMENTS ARE PERFORMED BY THE MANUFACTURER OR AT DIRECTION OF MANUFACTURER BY AN AUTHORIZED BENSON SERVICE FACILITY AND IS CONDITIONAL UPON RIGHT OF MANUFACTURER TO EXAMINE CLAIMED DEFECTS PRIOR TO THE START OF REPAIR OR REPLACEMENT.

D) REPAIR OR REPLACEMENT BY MANUFACTURER SHALL NOT EXTEND THE WARRANTY PERIOD.

E) MANUFACTURER EXPRESSLY DISCLAIMS ANY LIABILITY ARISING OUT OF NEGOTIATION, EXECUTION AND SALE OR USE OF THE EQUIPMENT FOR ANY INCIDENTAL OR CONSEQUENTIAL DAMAGES SUCH AS, BUT NOT LIMITED TO, DAMAGE OR LOSS OF OTHER PROPERTY OR EQUIPMENT, LOSS OF PROFITS OR REVENUES.

DOWNTIME, TRANSPORTATION EXPENSES DUE TO REPAIRS, COST OF REPLACEMENT GOODS OR CLAIMS FOR BUSINESS INTERRUPTIONS.

F) THIS WARRANTY IS EXCLUSIVE, AND MANUFACTURER MAKES NO WARRANTY, EXPRESSED OR IMPLIED, AS TO MERCHANTABILITY OR FITNESS FOR A PARTICULAR PURPOSE EXCEPT AS STATED IN THIS WARRANTY.

G) MANUFACTURER INCURS NO LIABILITY UNDER THIS WARRANTY OR OTHERWISE FOR EQUIPMENT EMPLOYED IN OTHER THAN NORMAL USE. NORMAL USE MEANS LOADING, UNLOADING, AND CARRIAGE OVER PROPERLY MAINTAINED PUBLIC HIGHWAYS OF UNIFORMLY DISTRIBUTED LEGAL LOADS OR CORRECTLY SECURED NON-CORROSIVE CARGO IN SUCH A MANNER THAT THE EQUIPMENT (INCLUDING EACH PART THEREOF) IS NOT SUBJECTED TO CONCENTRATED LOADS IN EXCESS OF THE RATED CAPACITIES AS SHOWN IN SECTION 4, LOAD IN EXCESS OF THE GROSS AXLE (GAWR) OR GROSS VEHICLE (GVW) WEIGHT RATINGS STATED ON THE CERTIFICATION PLATE AFFIXED TO THE EQUIPMENT AND SHOWN IN SECTION 4 BELOW. ACCIDENTAL OR FORK LIFT DAMAGE, OR SHOCK GREATER THAN THAT WHICH IS ORDINARILY ENCOUNTERED IN NORMAL USE.

H) SPECIAL EQUIPMENT ORDERED BY PURCHASER WHICH IS NOT STANDARD EQUIPMENT AS IS NORMALLY INSTALLED ON THE MODEL 524 AND 724 IS NOT WARRANTED BY THE MANUFACTURER. TO THE EXTENT PERMITTED BY THE MANUFACTURER OF SUCH SPECIAL EQUIPMENT, MANUFACTURER ASSIGNS TO PURCHASER ANY WARRANTY EXTENDED BY THE MANUFACTURER THEREOF.

I) PAINT AND COATINGS ARE CONSIDERED TO BE WEAR AND TEAR ITEMS AND ARE WARRANTED BY MANUFACTURER FOR 90 DAYS FROM DATE OF RETAIL DELIVERY AGAINST FAILURE TO ADHERE BY REASON OF DEFECTIVE SURFACE PREPARATION OR APPLICATION

J) STRUCTURAL MODIFICATIONS TO THE EQUIPMENT, EXCEPT AS PERFORMED BY OR AT THE DIRECTION OF MANUFACTURER, SHALL VOID THIS WARRANTY.

K) WARRANTY IS VOID IF DAMAGE TO EQUIPMENT RESULTS FROM CONTINUED USE AFTER A SUSPECTED DEFECT IS OR SHOULD HAVE BEEN DISCOVERED.

**SECTION 3. OBLIGATIONS OF PURCHASER**

A) PROMPTLY UPON DISCOVERY OF A SUSPECTED DEFECT, PURCHASER, AT ITS EXPENSE, SHALL RETURN THE EQUIPMENT TO MANUFACTURER OR TO AN AUTHORIZED BENSON SERVICE CENTER IF SO DESIGNATED BY THE MANUFACTURER, FOR INSPECTION TO DETERMINE WHETHER CORRECTION WILL BE MADE AT MANUFACTURER'S EXPENSE.

B) NO REPRESENTATIVE OF THE MANUFACTURER OR ANY OF ITS SALES AGENTS HAS THE AUTHORITY TO CHANGE, MODIFY, OR EXTEND THIS WARRANTY IN ANY MANNER, NOR HAVE THE AUTHORITY TO MAKE ANY EXPRESS WARRANTY WITH RESPECT TO THE EQUIPMENT. BY ACCEPTANCE OF THE EQUIPMENT AND THIS WARRANTY, PURCHASER ACKNOWLEDGES THAT NO REPRESENTATION, EITHER ORAL OR WRITTEN, HAVE BEEN GIVEN OR MADE BY REPRESENTATIVES OF THE MANUFACTURER OR ITS SALES OR SERVICE AGENTS AND PURCHASER HAS NOT RELIED ON ANY SUCH REPRESENTATIONS IN THE PURCHASE OF THE EQUIPMENT.

C) TO MAINTAIN THE EQUIPMENT IN GOOD WORKING ORDER IN A MANNER CONSISTENT WITH ACCEPTED INDUSTRY STANDARDS, INCLUDING BUT NOT LIMITED TO MAINTAINING PROPER TORQUE VALUES ON ALL SUSPENSION, UPPER COUPLER AND WHEEL FASTENERS.

**BENSON INTERNATIONAL, INC., MODEL 524 AND 724 PLATFORM TRAILER LIMITED WARRANTY (PAGE 2 OF 2)**

**SECTION 4. THE EQUIPMENT**

THE BENSON ALUMINUM PLATFORM TRAILER (THE EQUIPMENT) COVERED BY THIS WARRANTY IS IDENTIFIED AS FOLLOWS:

SERIAL NUMBER \_\_\_\_\_  
 MODEL NUMBER AND DECK RATINGS (CHECK APPROPRIATE MODEL)

- 524 - WITH 30 INCH KINGPIN SETTING - 100,000 POUNDS ENTIRE DECK, 70,000 POUNDS IN TEN FEET AND 52,000 POUNDS IN FOUR FEET (45,000 POUNDS IN FOUR FEET, FRONT 13 FEET OF DECK) ALL LOADS EVENLY DISTRIBUTED
- 724 - WITH 30 INCH KINGPIN SETTING - 140,000 LBS ENTIRE DECK, 70,000 POUNDS IN TEN FEET AND 72,000 POUNDS IN FOUR FEET, (65,000 POUNDS IN FOUR FEET, FRONT 13 FEET OF DECK) ALL LOADS EVENLY DISTRIBUTED

GROSS AXLE WEIGHT RATING (GAWR):  
 FRONT AXLE \_\_\_\_\_  
 \_\_\_\_\_  
 REAR AXLE \_\_\_\_\_  
 GROSS VEHICLE WEIGHT RATING (GVWR) \_\_\_\_\_  
 DATE OF MANUFACTURE \_\_\_\_\_  
 MODEL YEAR \_\_\_\_\_  
 DATE OF RETAIL DELIVERY \_\_\_\_\_



**SECTION 5. ACCEPTANCE OF EQUIPMENT BY PURCHASER**  
 I HEREBY ACKNOWLEDGE THAT I HAVE READ THIS BENSON LIMITED ALUMINUM PLATFORM TRAILER WARRANTY AND THAT I UNDERSTAND AND ACCEPT THE TERMS AND CONDITIONS OF THIS WARRANTY AS IT APPLIES TO THE EQUIPMENT IDENTIFIED IN SECTION 4 THAT I AM PURCHASING FROM THE MANUFACTURER OR THE MANUFACTURER'S AUTHORIZED BENSON ALUMINUM PLATFORM TRAILER DEALER.

PURCHASER'S SIGNATURE \_\_\_\_\_ TITLE \_\_\_\_\_ DATE \_\_\_\_\_  
 PURCHASER'S COMPANY NAME \_\_\_\_\_  
 PURCHASER'S ADDRESS \_\_\_\_\_  
 CITY \_\_\_\_\_ STATE \_\_\_\_\_ ZIP \_\_\_\_\_  
 AUTHORIZED DEALER SIGNATURE \_\_\_\_\_ TITLE \_\_\_\_\_ DATE \_\_\_\_\_  
 NAME OF AUTHORIZED DEALER \_\_\_\_\_  
 DEALER ADDRESS \_\_\_\_\_  
 CITY \_\_\_\_\_ STATE \_\_\_\_\_ ZIP \_\_\_\_\_

BENSON INTERNATIONAL, INC.  
 P. O. BOX 875  
 489 INTERNATIONAL DRIVE  
 CADIZ, KY 42211