



State of West Virginia  
 Department of Administration  
 Purchasing Division  
 2019 Washington Street East  
 Post Office Box 50130  
 Charleston, WV 25305-0130

# Request for Quotation

RFQ NUMBER  
 087026

PAGE  
 1

ADDRESS CORRESPONDENCE TO ATTENTION OF:  
 JOHN JOHNSTON  
 304-558-2402

VENDOR

\*709035240      304-755-5638  
 WV STEEL CORPORATION  
 PO BOX 1029  
 POCA WV 25159

SHIP TO

DIVISION OF HIGHWAYS  
 DISTRICT EIGHT  
 P.O. BOX 1516  
 US 219, NORTH PARSONS ROAD  
 ELKINS, WV  
 26241-1516      304-557-0215

DATE PRINTED 08/07/2006	TERMS OF SALE	SHIP VIA	F.O.B.	FREIGHT TERMS
BID OPENING DATE: 08/30/2006		BID OPENING TIME 01:30PM		

LINE	QUANTITY	UOP	CAT. NO.	ITEM NUMBER	UNIT PRICE	AMOUNT
0001	1	LB		570-84		\$32129.29
STRUCTURAL STEEL  TO PROVIDE STRUCTURAL STEEL FOR THE STONE HOUSE BRIDGE PROJECT NO. S342-25-4.41.  NOTE: BID UNIT PRICES MUST BE QUOTED AS PRICE PER LB.  SEE ATTACHED  VENDOR PREFERENCE CERTIFICATE  CERTIFICATION AND APPLICATION* IS HEREBY MADE FOR PREFERENCE IN ACCORDANCE WITH WEST VIRGINIA CODE, 5A-3-37 (DOES NOT APPLY TO CONSTRUCTION CONTRACTS).  A. APPLICATION IS MADE FOR 2.5% PREFERENCE FOR THE REASON CHECKED:  <input type="checkbox"/> BIDDER IS AN INDIVIDUAL RESIDENT VENDOR AND HAS RESIDED CONTINUOUSLY IN WEST VIRGINIA FOR FOUR (4) YEARS IMMEDIATELY PRECEDING THE DATE OF THIS CERTIFICATION; OR  <input checked="" type="checkbox"/> BIDDER IS A PARTNERSHIP, ASSOCIATION OR CORPORATION RESIDENT VENDOR AND HAS MAINTAINED ITS HEAD-QUARTERS OR PRINCIPAL PLACE OF BUSINESS CONTINUOUSLY I WEST VIRGINIA FOR FOUR (4) YEARS IMMEDIATELY PRECEDING THE DATE OF THIS CERTIFICATION; OR 80% OF THE OWNERSHIP INTEREST OF BIDDER IS HELD BY ANOTHER INDIVIDUAL, PARTNERSHIP, ASSOCIATION OR CORPORATION RESIDENT VENDOR WHO HAS MAINTAINED ITS HEADQUARTERS OR PRINCIPAL PLACE OF BUSINESS CONTINUOUSLY IN WEST VIRGINIA FOR FOUR (4)						

SEE REVERSE SIDE FOR TERMS AND CONDITIONS

SIGNATURE <i>[Signature]</i>	TELEPHONE 304 755 5638	DATE 8/30/06
TITLE Vice President	FEIN 580307435	ADDRESS CHANGES TO BE NOTED ABOVE

WHEN RESPONDING TO RFQ, INSERT NAME AND ADDRESS IN SPACE ABOVE LABELED 'VENDOR'





State of West Virginia  
 Department of Administration  
 Purchasing Division  
 2019 Washington Street East  
 Post Office Box 50130  
 Charleston, WV 25305-0130

# Request for Quotation

RFQ NUMBER  
 087026

PAGE  
 3

ADDRESS CORRESPONDENCE TO ATTENTION OF:  
 JOHN JOHNSTON  
 304-558-2402

VENDOR

\*709035240      304-755-5638  
 WV STEEL CORPORATION  
 PO BOX 1029  
 POCA WV 25159

SHIP TO

DIVISION OF HIGHWAYS  
 DISTRICT EIGHT  
 P.O. BOX 1516  
 US 219, NORTH PARSONS ROAD  
 ELKINS, WV  
 26241-1516      304-557-0215

DATE PRINTED 08/07/2006	TERMS OF SALE	SHIP VIA	F.O.B.	FREIGHT TERMS
BID OPENING DATE: 08/30/2006		BID OPENING TIME 01:30PM		

LINE	QUANTITY	UOP	CAT. NO.	ITEM NUMBER	UNIT PRICE	AMOUNT
<p>PREFERENCE, THE SECRETARY MAY ORDER THE DIRECTOR OF PURCHASING TO: (A) RESCIND THE CONTRACT OR PURCHASE ORDER ISSUED; OR (B) ASSESS A PENALTY AGAINST SUCH BIDDER IN AN AMOUNT NOT TO EXCEED 5% OF THE BID AMOUNT AND THAT SUCH PENALTY WILL BE PAID TO THE CONTRACTING AGENCY OR DEDUCTED FROM ANY UNPAID BALANCE ON THE CONTRACT OR PURCHASE ORDER.</p> <p>BY SUBMISSION OF THIS CERTIFICATE, BIDDER AGREES TO DISCLOSE ANY REASONABLY REQUESTED INFORMATION TO THE PURCHASING DIVISION AND AUTHORIZES THE DEPARTMENT OF TAX AND REVENUE TO DISCLOSE TO THE DIRECTOR OF PURCHASING APPROPRIATE INFORMATION VERIFYING THAT BIDDER HAS PAID THE REQUIRED BUSINESS TAXES, PROVIDED THAT SUCH INFORMATION DOES NOT CONTAIN THE AMOUNTS OF TAXES PAID NOR ANY OTHER INFORMATION DEEMED BY THE TAX COMMISSIONER TO BE CONFIDENTIAL.</p> <p>UNDER PENALTY OF LAW FOR FALSE SWEARING (WEST VIRGINIA CODE 61-5-3), BIDDER HEREBY CERTIFIES THAT THIS CERTIFICATE IS TRUE AND ACCURATE IN ALL RESPECTS; AND THAT IF A CONTRACT IS ISSUED TO BIDDER AND IF ANYTHING CONTAINED WITHIN THIS CERTIFICATE CHANGES DURING THE TERM OF THE CONTRACT, BIDDER WILL NOTIFY THE PURCHASING DIVISION IN WRITING IMMEDIATELY.</p> <p>BIDDER: <i>WV Steel Corp</i></p> <p>DATE: <i>8/30/06</i></p> <p>SIGNED: <i>[Signature]</i></p>						

SEE REVERSE SIDE FOR TERMS AND CONDITIONS			
SIGNATURE <i>[Signature]</i>	TELEPHONE	DATE <i>8/30/06</i>	
TITLE <i>V.P.</i>	FEIN <i>550307485</i>	ADDRESS CHANGES TO BE NOTED ABOVE	

WHEN RESPONDING TO RFQ, INSERT NAME AND ADDRESS IN SPACE ABOVE LABELED 'VENDOR'



State of West Virginia  
 Department of Administration  
 Purchasing Division  
 2019 Washington Street East  
 Post Office Box 50130  
 Charleston, WV 25305-0130

# Request for Quotation

RFQ NUMBER  
**087026**

PAGE  
**4**

ADDRESS CORRESPONDENCE TO ATTENTION OF:  
**JOHN JOHNSTON**  
**304-558-2402**

VENDOR

\*709035240      304-755-5638  
 WV STEEL CORPORATION  
 PO BOX 1029  
 POCA WV 25159

SHIP TO

DIVISION OF HIGHWAYS  
 DISTRICT EIGHT  
 P.O. BOX 1516  
 US 219, NORTH PARSONS ROAD  
 ELKINS, WV  
 26241-1516      304-557-0215

DATE PRINTED <b>08/07/2006</b>	TERMS OF SALE	SHIP VIA	F.O.B.	FREIGHT TERMS
BID OPENING DATE: <b>08/30/2006</b>		BID OPENING TIME <b>01:30PM</b>		

LINE	QUANTITY	UOP	CAT. NO.	ITEM NUMBER	UNIT PRICE	AMOUNT
				TITLE: <i>Vice President</i>		
	<p>* CHECK ANY COMBINATION OF PREFERENCE CONSIDERATION(S) IN EITHER "A" OR "B", OR BOTH "A" AND "B" WHICH YOU ARE ENTITLED TO RECEIVE. YOU MAY REQUEST UP TO THE MAXIMUM 5% PREFERENCE FOR BOTH "A" AND "B". (REV. 12/00)</p> <p>NOTICE</p> <p>A SIGNED BID MUST BE SUBMITTED TO:</p> <p>DEPARTMENT OF ADMINISTRATION          PURCHASING DIVISION          BUILDING 15          2019 WASHINGTON STREET, EAST          CHARLESTON, WV 25305-0130</p> <p>THE BID SHOULD CONTAIN THIS INFORMATION ON THE FACE OF THE ENVELOPE OR THE BID MAY NOT BE CONSIDERED:</p> <p>SEALED BID</p> <p>BUYER: 33</p> <p>RFQ. NO.: 0870026</p> <p>BID OPENING DATE AND TIME</p>					

SEE REVERSE SIDE FOR TERMS AND CONDITIONS

SIGNATURE <i>[Signature]</i>	TELEPHONE <i>304 755-5638</i>	DATE <i>8/30/06</i>
TITLE <i>V.P.</i>	FEIN <i>580307435</i>	ADDRESS CHANGES TO BE NOTED ABOVE

WHEN RESPONDING TO RFQ, INSERT NAME AND ADDRESS IN SPACE ABOVE LABELED 'VENDOR'



State of West Virginia  
 Department of Administration  
 Purchasing Division  
 2019 Washington Street East  
 Post Office Box 50130  
 Charleston, WV 25305-0130

# Request for Quotation

RFO NUMBER  
**087026**

PAGE  
**5**

ADDRESS CORRESPONDENCE TO ATTENTION OF:  
**JOHN JOHNSTON**  
**304-558-2402**

VENDOR

\*709035240      304-755-5638  
**WV STEEL CORPORATION**  
**PO BOX 1029**  
  
**POCA WV 25159**

SHIP TO

**DIVISION OF HIGHWAYS**  
**DISTRICT EIGHT**  
**P.O. BOX 1516**  
**US 219, NORTH PARSONS ROAD**  
**ELKINS, WV**  
**26241-1516      304-557-0215**

DATE PRINTED <b>08/07/2006</b>	TERMS OF SALE	SHIP VIA	F.O.B.	FREIGHT TERMS
BID OPENING DATE: <b>08/30/2006</b> BID OPENING TIME <b>01:30PM</b>				

LINE	QUANTITY	UOP	CAT. NO.	ITEM NUMBER	UNIT PRICE	AMOUNT
PLEASE PROVIDE A FAX NUMBER IN CASE IT IS NECESSARY TO CONTACT YOU REGARDING YOUR BID: ----- <i>304 755 2611</i> -----  CONTACT PERSON (PLEASE PRINT CLEARLY): ----- <i>Richard Smith</i> -----  ***** THIS IS THE END OF RFQ      087026 ***** TOTAL: <u><i>\$32129.29</i></u>						

SEE REVERSE SIDE FOR TERMS AND CONDITIONS

SIGNATURE <i>[Signature]</i>	TELEPHONE	DATE <i>8/20/06</i>
TITLE <i>V.P.</i>	FEIN <i>550307435</i>	ADDRESS CHANGES TO BE NOTED ABOVE

WHEN RESPONDING TO RFQ, INSERT NAME AND ADDRESS IN SPACE ABOVE LABELED 'VENDOR'

Item No.	Quantity	Description	Unit Price	Amount
1	18,405 lbs	W24x68, Galvanized W-Shaped Structural Steel, AASHTO M270, Grade 50. Ship: 8 pcs. @ 33' -10" fabricated in accordance with Sketch # 1.	<u>.9700</u>	<u>17852.85</u>
2	2,000 lbs.	C12x25, Galvanized Structural Steel Channel, AASHTO M270, Grade 50. Ship: 4 pcs @ 20' -0"	<u>1.26</u>	<u>2520.<sup>20</sup></u>
3	1,296 lbs.	L 6" x 4" x 1/2" (16.2 #/LF) Galvanized Structural Steel Angle, AASHTO M270, Grade 50. Ship: 4 pcs. @ 20' -0"	<u>1.19</u>	<u>1542.24</u>
4	691 lbs.	L 4" x 4" x 1/2" (12.8 #/LF) Galvanized Structural Steel Angle, AASHTO M270, Grade 50. Ship: 54 pcs @ 1' -0" fabricated in accordance with Sketch # 2.	<u>1.63</u>	<u>1126.33</u>
5	2,819 lbs.	6" x 6" x 1/2" Galvanized Structural Steel Tubing (35.24 #/LF) ASTM A500 Ship: 4 pcs. @ 20' -0"	<u>1.08</u>	<u>3044.52</u>
6	2,040 lbs.	3/4" x 10" Galvanized Structural Steel Plate, (25.5 #/LF), AASHTO M270, Grade 50. Ship: 4 pcs. @ 20' -0"	<u>1.28</u>	<u>2611.20</u>
7	306 lbs.	3/4" x 6" Galvanized Structural Steel Bar (15.3 #/LF) AASHTO M270, Grade 50. Ship: 2 pcs. @ 10' -0	<u>1.84</u>	<u>563.04</u>
8	<del>562</del> 306 lbs.	<del>3/4" x 6"</del> 3/4" x 6" Galvanized Structural Steel Bar (28.1 #/LF) AASHTO M270, Grade 50. Ship: 2 pcs. @ 10' -0	<u>1.84</u>	<u>563.04</u>
9	3129 lbs.	No. 5 Galvanized Reinforcing Steel Bar (1.043 #/LF) AASHTO M31, Grade 60. Ship: 150 pcs. @ 20' -0	<u>.737</u>	<u>2306.07</u>

TOTAL

\$ 32129.29

Item No.	Quantity	Description	Unit Price	Amount
		<ol style="list-style-type: none"><li>1. The above listed materials are to be delivered to the WVDOH, District Eight lot, located on US Route 219, approximately 1 mile north of Elkins WV.</li><li>2. The District Eight Storekeeper must be notified at (304) 637-0226 at least 48 hours in advance of delivery to provide necessary personnel and equipment for unloading.</li><li>3. Delivery will only be accepted during normal working hours of 7:30am to 4:00pm, Monday - Friday.</li><li>4. All galvanizing shall be in accordance with AASHTO MIII.</li><li>5. Steel designated as AASHTO M270 shall conform to Section S4. Non-Fracture-Critical, Zone 2, toughness testing and requirements.</li></ol>		

W. Va. Dept. of Transportation—Division of Highways  
District 8; PO Box 1516  
Elkins, WV 26241

PO No. 087-0026  
Page No. 4 of 5  
Sketch No. 1

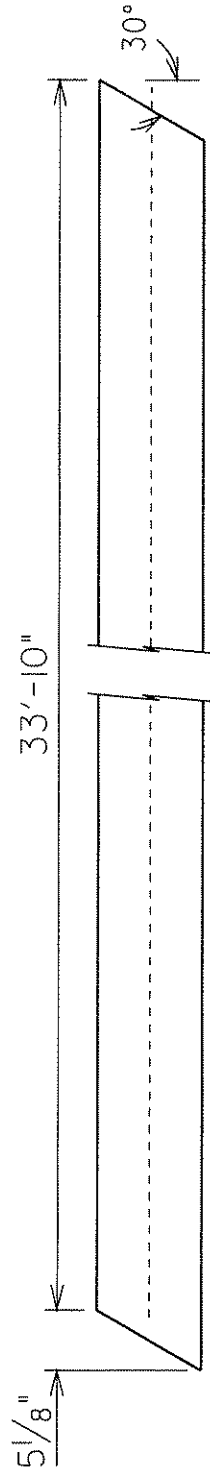

W24x68 W-Shaped Girder  
(8- Required)



W. Va. Department of Transportation  
Division of Highways, District 8  
PO Box 1516  
Elkins, WV 26241  
RPO No. 087-0026  
Page No. 5 of 5  
Sketch No. 2

ALL HOLES  $1\frac{3}{16}$ " DIAMETER

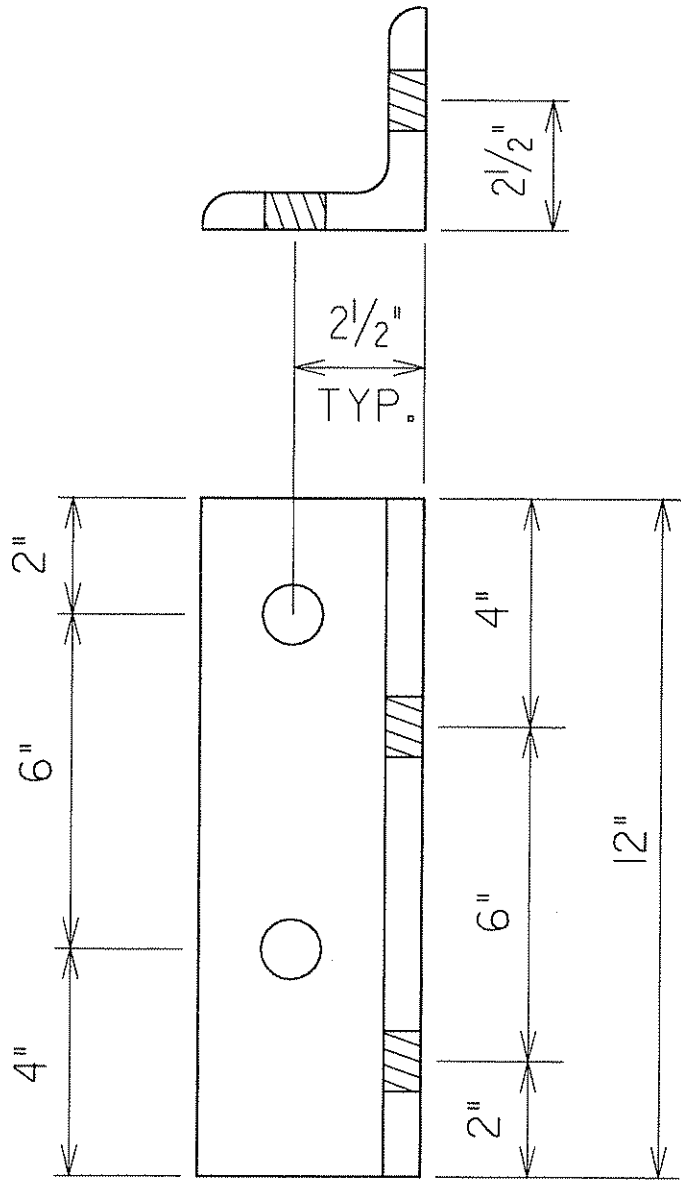

CLIP ANGLE

ANGLE 4"x4"x1/2" - 54 REQUIRED

# A F F I D A V I T

**West Virginia Code §5A-3-10a states:**

No contract or renewal of any contract may be awarded by the state or any of its political subdivisions to any vendor or prospective vendor when the vendor or prospective vendor or a related party to the vendor or prospective vendor is a debtor and the debt owned is an amount greater than one thousand dollars in the aggregate.

**DEFINITIONS:**

"Debt" means any assessment, premium, penalty, fine, tax or other amount of money owed to the state or any of its political subdivisions because of a judgment, fine, permit violation, license assessment, defaulted workers' compensation premium, penalty or other assessment presently delinquent or due and required to be paid to the state or any of its political subdivisions, including any interest or additional penalties accrued thereon.

"Debtor" means any individual, corporation, partnership, association, limited liability company or any other form or business association owing a debt to the state or any of its political subdivisions.

"Political subdivision" means any county commission; municipality; county board of education; any instrumentality established by a county or municipality; any separate corporation or instrumentality established by one or more counties or municipalities, as permitted by law; or any public body charged by law with the performance of a government function or whose jurisdiction is coextensive with one or more counties or municipalities.

"Related party" means a party, whether an individual, corporation, partnership, association, limited liability company or any other form or business association or other entity whatsoever, related to any vendor by blood, marriage, ownership or contract through which the party has a relationship of ownership or other interest with the vendor so that the party will actually or by effect receive or control a portion of the benefit, profit or other consideration from performance of a vendor contract with the party receiving an amount that meets or exceeds five percent of the total contract amount.

**EXCEPTION:**

The prohibition of this section does not apply where a vendor has contested any tax administered pursuant to chapter eleven of this code, workers' compensation premium, permit fee or environmental fee or assessment and the matter has not become final or where the vendor has entered into a payment plan or agreement and the vendor is not in default of any of the provisions of such plan or agreement.

**LICENSING:**

The vendor must be licensed in accordance with any and all state requirements to do business with the state of West Virginia.

**CONFIDENTIALITY:**

The vendor agrees that he or she will not disclose to anyone, directly or indirectly, any such personally identifiable information or other confidential information gained from the agency, unless the individual who is the subject of the information consents to the disclosure in writing or the disclosure is made pursuant to the agency's policies, procedures and rules. Vendors should visit [www.state.wv.us/admin/purchase/privacy](http://www.state.wv.us/admin/purchase/privacy) for the Notice of Agency Confidentiality Policies.

Under penalty of law for false swearing (West Virginia Code, §61-5-3), it is hereby certified that the vendor acknowledges the information in this said affidavit and are in compliance with the requirements as stated.

Vendor's Name: WV Steel Corp

Authorized Signature: [Signature] Date: 7/30/06