



The following documentation is an electronically-submitted vendor response to an advertised solicitation from the *West Virginia Purchasing Bulletin* within the Vendor Self-Service portal at [wvOASIS.gov](http://wvOASIS.gov). As part of the State of West Virginia's procurement process, and to maintain the transparency of the bid-opening process, this documentation submitted online is publicly posted by the West Virginia Purchasing Division at [WVPurchasing.gov](http://WVPurchasing.gov) with any other vendor responses to this solicitation submitted to the Purchasing Division in hard copy format.

## Header @ 4

[List View](#)

## General Information

[Contact](#)[Default Values](#)[Discount](#)[Document Information](#)[Clarification Request](#)

Procurement Folder: 1387185

Procurement Type: Central Master Agreement

Vendor ID: 000000176437 

Legal Name: TRANSPORTATION EQUIPMENT SALES CORP

Alias/DBA:

Total Bid: \$828,860.00

Response Date: 05/30/2024 

Response Time: 13:11

Responded By User ID: TESCO 

First Name: Jeffrey

Last Name: Pappas

Email: jpappas@tescobus.com

Phone: 800-227-3572

SO Doc Code: CRFQ

SO Dept: 0810

SO Doc ID: DMT2400000006

Published Date: 5/13/24

Close Date: 5/30/24

Close Time: 13:30

Status: Closed

Solicitation Description: ADA Compliant Lowered Floor Minivans

Total of Header Attachments: 4

Total of All Attachments: 4



Department of Administration  
 Purchasing Division  
 2019 Washington Street East  
 Post Office Box 50130  
 Charleston, WV 25305-0130

**State of West Virginia  
 Solicitation Response**

**Proc Folder:** 1387185  
**Solicitation Description:** ADA Compliant Lowered Floor Minivans  
**Proc Type:** Central Master Agreement

Solicitation Closes	Solicitation Response	Version
2024-05-30 13:30	SR 0810 ESR05302400000007442	1

**VENDOR**  
 000000176437  
 TRANSPORTATION EQUIPMENT SALES CORP

**Solicitation Number:** CRFQ 0810 DMT2400000006  
**Total Bid:** 828860  
**Response Date:** 2024-05-30  
**Response Time:** 13:11:42  
**Comments:**

**FOR INFORMATION CONTACT THE BUYER**  
 John W Estep  
 304-558-2566  
 john.w.estep@wv.gov

**Vendor Signature X** **FEIN#** **DATE**

All offers subject to all terms and conditions contained in this solicitation

Line	Comm Ln Desc	Qty	Unit Issue	Unit Price	Ln Total Or Contract Amount
1	ADA Lowered Floor Minivans	10.00000	EA	82886.000000	828860.00

Comm Code	Manufacturer	Specification	Model #
25101502			

**Commodity Line Comments:**

**Extended Description:**

To establish an open-ended contract for ADA Lowered Floor Minivans. These vehicles will not possess any graphics.



Proven Quality.  
Trusted Name.

Transportation Equipment Sales Corporation

May 29, 2024

John Estep  
Department of Administration  
Purchasing Division  
2019 Washington St., East  
Charleston, WV 25305

**RE: CRFQ 0810 DMT2400000006  
ADA Compliant Lowered Floor Minivans**

Dear John:

Thank you for the invitation to submit a bid for ADA compliant lowered floor minivans. We are pleased to offer a Chrysler Voyager/Pacifica with an FR Conversions upfit.

Regarding the swing out feature of the ramp. This feature is not available as only one manufacturer in the industry offers it.

We appreciate the opportunity to work with you on this contract. Please contact me at 1-800-227-3572 if you have any questions regarding this proposal.

Sincerely,

Jeffrey P. Pappas  
Vice President



Proven Quality.  
Trusted Name.

Transportation Equipment Sales Corporation

## Vehicle Documentation

3.3.1.1 Engine: FR Conversions uses the Chrysler Voyager OEM engine. Information can be found in the Chrysler Voyager brochure.

3.6.1 Transmission: FR Conversions uses the Chrysler Voyager OEM transmission. Information can be found in the Chrysler Voyager brochure.

3.6.4 Back Up Camera System: FR Conversions uses the Chrysler Voyager OEM back up camera system. Information can be found in the Chrysler Voyager brochure.

3.11 Tires: FR Conversions uses the Chrysler Voyager OEM tires. Information can be found in the Chrysler Voyager brochure.

3.19.2 Floor Covering: FR Conversions uses Altro Transflor Wood flooring. A brochure showing samples and colors has been included in this response.

3.22 Seating: FR Conversions uses the Chrysler Voyager OEM seats for all seats except the double foldaway seat which comes from Freedman Seating. Information on the Freedman 3PT foldaway double seat has been included in this response.

3.2201 Driver's Seat: FR Conversions uses the Chrysler Voyager OEM driver seat. Information can be found in the Chrysler Voyager brochure.

3.27 Wheelchair Securement System: Information on the Q'Straint QRT Max Series system has been included in this response.

3.28 Wheelchair Occupant Restraint System: Information on the Q'Straint QRT Max Series system has been included in this response.

3.35 Training: A letter of understanding of the terms in this Section has been included in this response.

3.31.5 Security Camera: The Angeltrax 6 camera system documentation has been included in this response.

5.9.1 Warranty on complete vehicle: Warranty information on the Chrysler Voyager and FR Conversions upfit has been included in this response.



Proven Quality.  
Trusted Name.

Transportation Equipment Sales Corporation

5.9.2 Warranty on Basic Vehicle Structure: Warranty information on the Chrysler Voyager and FR Conversions upfit has been included in this response.

5.9.4 Warranties to be provided on subsystems and components: Warranty information has been included in this response.

10.2 H. Conversion Location: The van final assembly is located at FR Conversions, 1231 Tech Ct, Westminster MD 21157.

10.2 I. References: A list of five (5) users names, addresses, emails and telephone numbers who have been provided similar equipment by the Vendor has been included in this response.



Proven Quality. Trusted Name.

## WV DOT

**3.3.1.1 Engine:** FR Conversions uses the Chrysler Voyager OEM engine.

---

**3.6.1 Transmission:** FR Conversions uses the Chrysler Voyager OEM transmission.

---

**3.6.4 Back Up Camera System:** FR Conversions uses the Chrysler Voyager OEM back up camera system.

---

**3.11 Tires:** FR Conversions uses the Chrysler Voyager OEM tires.

---

**3.2201 Driver's Seat:** FR Conversions uses the Chrysler Voyager OEM driver seat.

**Information can be found in the Chrysler Voyager brochure.**

# 2024 CHRYSLER PACIFICA/CHRYSLER PACIFICA PHEV/CHRYSLER VOYAGER



## SELECT FEATURES

- 7-inch Digital Cluster
- Active Noise Cancellation
- Electronic Stability Control (ESC)<sup>(6)</sup>
- Fuel Tank – 19-gallon on gas/16.5-gallon on Hybrid
- Locking Glove Box
- Passive/Keyless Entry, All Doors
- Power Driver's Seat with Auto Advance 'n Return
- Power Outlet – 12-volt
- Power-Sliding Doors and Liftgate
- Rear Window Defroster
- Remote Start<sup>(12)</sup> System/Security Alarm<sup>(24)</sup>
- Storage Floor Tray
- Uconnect<sup>®</sup> 5 with 10.1-inch HD Touchscreen Radio

## SAFETY & SECURITY

- 360° Surround-View Camera<sup>(1)</sup> (Available)
- Adaptive Cruise Control (ACC) with Stop and Go<sup>(2)</sup>
- Air Bags<sup>(21)</sup> – Advanced multistage driver's and front-passenger include low-risk deployment
  - Supplemental driver's and front-passenger front-seat-mounted side
  - Driver's and front-passenger inflatable knee blocker
  - Supplemental side-curtain for outboard passengers in all three rows
- Auto High-Beam Headlamp Control
- Automatic Pedestrian Emergency Braking<sup>(8)</sup>
- Full-Speed Forward Collision Warning Plus<sup>(6)</sup>
- LaneSense<sup>®</sup> Lane Departure Warning Plus with Lane Keep Assist<sup>(10)</sup>
- LED Exterior Lighting
- Parallel and Perpendicular Park Assist with Stop<sup>(11)</sup> (Available)
- ParkSense<sup>®</sup> Front Park Assist with Stop<sup>(11)</sup> (Available)
- Rain-Sensitive Windshield Wipers
- Sentry Key<sup>®</sup> Antitheft Engine Immobilizer

ENGINES	HORSEPOWER <sup>(22)</sup>	TORQUE <sup>(22)</sup>
3.6L Pentastar <sup>®</sup> V6 VVT	287 hp @ 6,400 rpm	262 lb-ft @ 4,000 rpm
3.6L Pentastar V6 Hybrid Atkinson Cycle	260-hp (194-kW) total system power	–

EXTERIOR DIMENSIONS*	
Wheelbase	121.6
Overall Length	204.3
Overall Width	79.6
Height (FWD / AWD)	69.9 / 70.7
Turning Diameter (max; ft; FWD / AWD)	39.7 / 40.2
Front Track (FWD / AWD / Hybrid)	68.3 / 68.8 / 68.2
Rear Track (FWD / AWD / Hybrid)	68.3 / 68.8 / 68.2
Base Curb Weight (FWD / AWD / Hybrid)	4,521 / 4,883 / 5,010

CARGO AND FUEL	
Maximum Interior Cargo Room (cu ft; behind first row)	140.5
Maximum Interior Cargo Room (cu ft; behind second row)	87.5
Maximum Interior Cargo Room (cu ft; behind third row)	32.3
Fuel Tank (gal; gas / Hybrid)	19 / 16.5

FUEL ECONOMY <sup>(18)</sup>	
Fuel Economy (manufacturer's-estimated mpg)	City / Hwy
– 3.6L Pentastar V6 VVT FWD / AWD	19 / 28 / 17 / 25
– 3.6L Pentastar V6 Hybrid Atkinson Cycle	82 MPGe <sup>(26)</sup>

INTERIOR DIMENSIONS*	
First Row	
– Headroom (without sunroof)	40.1
– Legroom	41.1
– Shoulder room	63.8
– Hip room	59
Second Row	
– Headroom (without sunroof)	39.6
– Legroom	39
– Shoulder room	63
– Hip room	64.8
Third Row	
– Headroom	38.7
– Legroom	36.5
– Shoulder room	61.2
– Hip room	49.5

\*Based on 2023MY vehicle information. All dimensions are in inches unless otherwise noted. Information may vary by model/trim.

# 2024 CHRYSLER PACIFICA/CHRYSLER PACIFICA PHEV/CHRYSLER VOYAGER

## EXTERIOR PAINT COLORS

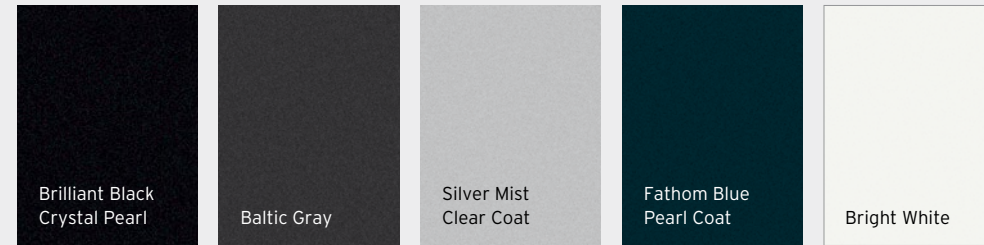

### STANDARD FEATURES AND OPTIONS

CPOS	Voyager 2DE	Pacifica Touring 2DW	Pacifica Touring L 2DL	Pacifica Limited 2DP	Pacifica Pinnacle™ 2DS
<b>ENGINES / TRANSMISSIONS</b>					
3.6L Pentastar® V6 Variable Valve Timing (VVT) with Engine Stop/Start (ESS) Technology and 9-speed Automatic (ERC/DFH)	•	•	•	•	•
3.6L Pentastar V6 Hybrid Atkinson Cycle with Electrically Variable Transmission (EVT) (EH3/DFQ)			0	0	0
<b>MECHANICAL FEATURES</b>					
All-Wheel Drive (AWD) (non-Hybrid only)			0	0	0
– Front-Wheel Drive (FWD)	•	•	•	•	•
Alternator – 180-amp (non-Hybrid only) (BAD)	•	•	•		
– 220-amp (included with Uconnect® Theater Family Group and Premium Package; non-Hybrid only) (BAJ)			P	•	•
– Alternator Delete (Hybrid only) (BA8)			P	P	P
Battery – 650-amp, Absorbent Glass Mat (AGM) (BCZ)	•	•	•	•	•
– Auxiliary battery (packaged with ESS dual battery system; non-Hybrid only) (BC1)		P	P	P	P
– Battery charge indicator (Hybrid only) (XAT)			P	P	P
6.6-kW Battery Charger with Cord (Hybrid only) (XFE)			P	P	P
Brakes – Four-wheel antilock disc regenerative brakes (Hybrid only) (BRT)			P	P	P
– Four-wheel antilock with discs (FWD non-Hybrid only) (BRG)	•	•	•	•	•
– Four-wheel antilock with heavy-duty discs (AWD only) (BR3)			P	P	P
Engine Block Heater (non-Hybrid only) (NHK)	•	0	0	0	0
Defroster – Rear (GFA)	•	•	•	•	•
Fuel Tank – 16.5-gallon (Hybrid only) (NF3)			P	P	P
– 19-gallon (non-Hybrid only) (NF1)	•	•	•	•	•
Suspension – Heavy-duty (Hybrid only) (SDB)			P	P	P
– AWD (non-Hybrid only) (SDE)			P	P	P

### STANDARD FEATURES AND OPTIONS

CPOS	Voyager 2DE	Pacifica Touring 2DW	Pacifica Touring L 2DL	Pacifica Limited 2DP	Pacifica Pinnacle™ 2DS
<b>MECHANICAL FEATURES (CONTINUED)</b>					
Suspension (continued) – Touring (non-Hybrid only) (SDC)	•	•	•	•	•
Tip Start (XBN)	•	•	•	•	•
<b>EXTERIOR FEATURES</b>					
Daylight Opening – Bright (not available with S Appearance Package or 18-inch S Appearance Package) (MMP)	•	•	•	•	
– Black (included with S Appearance Package and 18-inch S Appearance Package) (MMR)		P	P	P	
– Platinum Chrome (MMF)					•
Door Handles – Body-color (included with S Appearance Package) (MNK)	•	•	•	•	
– Platinum Chrome (MNU)					•
Doors – Power-sliding (JRK)	•	•	•	•	•
– Hands-free power-sliding doors (included with Uconnect Theater Family Group and Premium Package) (XZ3)			P	P	•
Fog Lamps – LED (LNV)		•	•	•	•
– Chrome accent bezels (LTB)		•	•	•	•
Glass – Sunscreen (GAE)	•	•	•	•	•
– Acoustic windshield (GAK)		•	•	•	•
– Laminated front-door glass (GAP)			P	•	•
Grille – Black (MFS)	•				
– Black upper with Bright surround (MFF)		•	•	•	•
– Black with Gloss Black surround (included with S Appearance Package and 18-inch S Appearance Package) (ML1)		P	P	P	
Headlamps – Halogen (LMA)	•				
– Auto High-Beam Control (LMS)		•	•	•	•
– Automatic (LMG)		•	•	•	•
– LED low-/high-beam (LM6)		•	•	•	•

• = Standard. 0 = Optional. P = Available with Package noted. F = Fleet only.

# 2024 CHRYSLER PACIFICA/CHRYSLER PACIFICA PHEV/CHRYSLER VOYAGER

STANDARD FEATURES AND OPTIONS	Voyager	Pacifica Touring	Pacifica Touring L	Pacifica Limited	Pacifica Pinnacle™
CPOS	2DE	2DW	2DL	2DP	2DS
<b>EXTERIOR FEATURES (CONTINUED)</b>					
Headlamps (continued) – Daytime running (LM1)		•	•	•	•
Liftgate – Power (JRC)	•	•	•	•	•
– Hands-free power (included with Uconnect® Theater Family Group and Premium Package) (XZ2)			P	•	•
Mirrors – Power, Black, heated (GPK)	•				
– Foldaway, power, heated, Gloss Black with supplemental turn indicator (GUR)		•	•		
– Power-folding, power-adjust, heated with memory feature, courtesy lamps, supplemental turn indicator, auto-adjust-in-Reverse and auto-fold-in-Park with Gloss Black exterior (memory mirrors not available on Hybrid) (GPL)				•	
– Power-folding, power-adjust, heated with memory feature, courtesy lamps, supplemental turn indicator, auto-adjust-in-Reverse and auto-fold-in-Park with Platinum Chrome/Body-color exterior (GU5)					•
Molding – Bodyside, Bright (not available with S Appearance Package; non-Hybrid only) (MHE)				•	
– Platinum Chrome (MJB)					•
Roof Rack – Stow N Place®, Black (non-Hybrid only; packaged with S Appearance Package and 18-inch S Appearance Package) (MW1)		P	P	P	
– Stow N Place with Platinum Chrome side rails (MNF)					•
Sill Appliqué – Body-color (MPK)	•	•	•	•	•
Sill – Bright front-door scuff pads (CLT)					•
Tires – 235/65R17 BSW All-Season (A/S) (standard on Front-Wheel Drive (FWD) Voyager, Touring and Touring L models) (TMK)	•	•	•		
– 235/60R18 BSW A/S self-sealing (included with S Appearance Package; Hybrid only) (TMH)			P		
– 235/60R18 BSW A/S (included with S Appearance Package; not available on Pinnacle FWD/All-Wheel Drive (AWD)) (TWZ)				P	•
– 245/50R20 BSW A/S self-sealing (non-Hybrid only; included with S Appearance Package) (TP3)			P	P	•
– 245/60R18 BSW A/S self-sealing (non-Hybrid only; included with S Appearance Package and 18-inch S Appearance Package on FWD Touring) (TJK)		P		•	
– Puncture sealant and portable air compressor (standard on FWD Voyager, Touring, Touring L, and all Hybrid models) (XAH)	•	•	•	•	•
Sunroof – Dual-pane panoramic – Power front, fixed rear (includes power open/close shade) (GWJ)			O	•	•
Wheels – 17-inch fully painted Tech Silver cast aluminum (standard on FWD Voyager, Touring and Touring L) (WFN)	•	•	•		
– 17-inch Diamond-Cut with Baltic Gray pockets aluminum (WJR)				•	
– 18-inch Foreshadow-finish aluminum (included with S Appearance Package; Hybrid only) (WP6)			P	P	
– 18-inch polished aluminum wheels (Touring FWD) (WDR)		O			
– 18-inch painted aluminum (non-Hybrid only) (WBA)				•	
– 18-inch Foreshadow-finish aluminum (included with S Appearance Package and 18-inch S Appearance Package; non-Hybrid only) (WK3)		P	P		
– 18-inch painted aluminum (non-Hybrid only; standard on AWD Touring L) (WBS)			•		
– 18-inch polished with Baltic Gray pockets aluminum (Hybrid only) (WDP)					•

• = Standard. O = Optional. P = Available with Package noted. F = Fleet only.

STANDARD FEATURES AND OPTIONS	Voyager	Pacifica Touring	Pacifica Touring L	Pacifica Limited	Pacifica Pinnacle™
CPOS	2DE	2DW	2DL	2DP	2DS
<b>EXTERIOR FEATURES (CONTINUED)</b>					
Wheels (continued) – 20-inch Foreshadow-finish aluminum (non-Hybrid only; included with S Appearance Package) (WPF)			P	P	
– 20-inch polished with Baltic Gray pockets aluminum (non-Hybrid only) (WH5)					•
Windshield Wipers – Front, variable intermittent (JHA)	•				
– Front, rain-sensitive (JHC)		•	•	•	•
– Rear wiper/washer (JHB)	•	•	•	•	•
<b>INTERIOR FEATURES</b>					
Air Conditioning – Three-Zone temperature control (HAK)	•				
– Three-Zone automatic temperature control (HAH)		•	•	•	•
Door Locks – Power (JPB)	•	•	•	•	•
Chrysler Air Filtration System	•	•	•	•	•
Headliner – Deluxe (CHE)	•	•	•	•	
– Suede (CHG)					•
Grocery Bag Hooks – On third-row seatbacks (XGH)			•	•	•
Lighting – Front and rear LED lamps (LBR)	•	•	•	•	•
– Cargo compartment lamp (LDB)	•	•	•	•	•
– Footwell courtesy lamp (LBB)					•
– Interior door handle LED lamps (LB3)			•	•	•
– Front, courtesy lamp (LCA)	•	•	•	•	•
– Glove box lamp (LBC)		•	•	•	•
– Liftgate floodlamp (LDF)		•	•	•	•
– Overhead, ambient surround (LCJ)	•	•	•	•	•
– Rear reading/courtesy lamps (LBH)		•	•	•	•
– Rear ambient lighting (LCU)					•
– Illuminated map pocket and puddle lamp (LCN)					•
Mirrors – Auto-dimming rearview (included with Uconnect Theater Family Group) (GNK)			P	•	•
– Illuminated visor vanity (GN9)	•	•	•	•	•
Power Outlets – Auxiliary, 12-volt (JJJ/JKP)	•	•	•	•	•
– Auxiliary, 115-volt (included with Uconnect Theater Family Group and Premium Package) (JKV)			P	P	•
Remote Start <sup>(2)</sup> System (XBM)	•	•	•	•	•
Shades – Second- and third-row retractable (non-Hybrid only; included with Uconnect Theater Family Group) (GF1)			P	•	•
– Second-row (non-Hybrid only) (GF3)			•		
– Second- and third-row retractable (Hybrid only) (GF1)				P	•
Steering Column – Tilt/telescoping (SUD)	•	•	•	•	•
Steering Wheel – Heated (NHS)	•	•	•	•	•

# 2024 CHRYSLER PACIFICA/CHRYSLER PACIFICA PHEV/CHRYSLER VOYAGER

STANDARD FEATURES AND OPTIONS	Voyager	Pacifica Touring	Pacifica Touring L	Pacifica Limited	Pacifica Pinnacle™
CPOS	2DE	2DW	2DL	2DP	2DS
<b>INTERIOR FEATURES (CONTINUED)</b>					
Steering Wheel (continued) – Mounted audio controls (RDZ)	•	•	•	•	•
– Techno-leather-wrapped (SCJ)	•	•	•	•	•
Storage – Floor tray (CVU)		•	•	•	•
– Floor console (CUC)	•				
– Full-length upgraded floor console (CUP)		•			
– Super Console with covered storage (includes illuminated cup holders) (CM7)			•	•	
– Integrated Premium Console (includes illuminated cup holders) (CM5)				•	
– Integrated Ultra Console (includes illuminated cup holders) (CVM)					•
– Glove box, locking (JKA)	•	•	•	•	•
– Lower instrument panel drawer (RF9)	•	•	•		
Stow 'n Vac Integrated Vacuum Cleaner (non-Hybrid only; included with Uconnect® Theater Family Group and Premium Package) (CJW)			P	P	•
Trip Computer – Electronic Vehicle Information Center (EVIC) 7-inch configurable digital display in instrument cluster; controls mounted on steering wheel (LAZ)	•	•	•	•	•
Universal Garage Door Opener (XGD)				•	•
Windows – Front, power with driver's one-touch up/down, front-passenger one-touch down (JP3)	•	•	•		
– Power front and rear one-touch up/down (included with Uconnect Theater Family Group and Premium Package) (JSB)			P	•	•
– Power second-row (JPG)	•	•	•	•	•
Wireless Charging Pad (RFX)				•	•
<b>SEATING AND TRIM</b>					
Seats – Driver's four-way power lumbar-adjust (included with power driver's seat) (JPU)	•	•	•	•	•
– Eight-way power driver's (JVG)	•	•	•	•	•
– Eight-way power front-passenger (included with Uconnect Theater Family Group and Premium Package) (JWG)			P	•	•
– Heated second-row (non-Hybrid only; included with Uconnect Theater Family Group and Premium Package) (JPZ)			P	•	•
– Heated front (JPM)	•	•	•	•	•
– Cloth bucket (*H7)	•	•			
– Caprice leatherette-trimmed bucket (*SJ)			•	•	
– Premium Nappa leather-trimmed bucket (*AL)				•	
– Premium Nappa leather-trimmed quilted bucket (*DL)					•
– Caprice leatherette-trimmed with S logo (included with S Appearance Package and 18-inch S Appearance Package) (*GJ)			P		
– Premium Nappa leather-trimmed with S logo (included with S Appearance Package) (*RL)				P	
– Second- and third-row Stow 'n Go® that fold in the floor and include second-row in-floor storage bins (non-Hybrid only) (CYC)	•	•	•	•	

STANDARD FEATURES AND OPTIONS	Voyager	Pacifica Touring	Pacifica Touring L	Pacifica Limited	Pacifica Pinnacle™
CPOS	2DE	2DW	2DL	2DP	2DS
<b>SEATING AND TRIM (CONTINUED)</b>					
Seats (continued) – Easy slide second-row Captain's Chairs (Hybrid and Pinnacle) (CY3)			•	•	•
– Auto Advance 'n Return, driver's-side (non-Hybrid only) (CJK)		•	•	•	•
– Auto Advance 'n Return, passenger-side (non-Hybrid only; included with Uconnect Theater Family Group and Premium Package) (CJZ)			P	•	•
– Third-row power-folding Stow 'n Go 60/40 split-bench that folds in the floor (non-Hybrid only; included with Uconnect Theater Family Group) (JRJ)				P	•
– Third-row Stow 'n Go 60/40 split-bench that folds in the floor (CFX)	•	•	•	•	•
– Eight-passenger seating (included with Uconnect Theater Family Group and Premium Package; Front-Wheel Drive (FWD) non-Hybrid only) (CYF)			P		
– Ventilated front (CAJ)				•	•
<b>UCONNECT MULTIMEDIA</b>					
SiriusXM® Radio <sup>(13)</sup> (three-month trial subscription) (RSD)	•	•	•	•	•
Sound Systems – Harman Kardon® 20 speakers (includes 760-watt amplifier; standard on Pinnacle Hybrid; included with Uconnect Theater Family Group) (RGE)				P	•
– Harman Kardon 19 speakers with 10-inch subwoofer (includes 760-watt amplifier; non-Hybrid only; included with Uconnect Theater Family Group) (RCA)				P	•
– Alpine® 13 speakers (includes 506-watt amplifier; included with Uconnect Theater Family Group and Premium Package) (RC3)			P	•	
– Six speakers (includes Active Noise Cancellation) (RCG)	•	•	•	•	
Uconnect 5 with 7-inch Display – Includes 7-inch touchscreen, AM/FM, USB host flip, hands-free phone and audio, Android Auto, <sup>TM(3)</sup> Apple CarPlay <sup>TM(4)</sup> and available SiriusXM Radio <sup>(13)</sup> (UBC)	•				
Uconnect 5 with 10.1-inch Display – Includes 10.1-inch touchscreen, AM/FM, USB host flip, hands-free phone and audio, Android Auto, <sup>(3)</sup> Apple CarPlay <sup>(4)</sup> and available SiriusXM with 360L <sup>(13)</sup> (UBG)		•	•		
Uconnect 5 NAV with 10.1-inch Display – Includes 10.1-inch touchscreen, AM/FM, USB host flip, Integrated Voice Command, Android Auto, <sup>(3)</sup> Apple CarPlay, <sup>(4)</sup> HD radio, Navigation and available SiriusXM with 360L <sup>(13)</sup> (included with Uconnect Theater Family Group) (UBN)			P	•	•
Integrated Voice Command (included with Uconnect 5 NAV with 10.1-inch display) (XRB)			P	•	•
<b>SAFETY &amp; SECURITY</b>					
Adaptive Cruise Control (ACC) with Stop and Go <sup>(2)</sup> (NHZ)		•	•	•	•
Air Bags <sup>(21)</sup> – Advanced multistage driver's and front-passenger (CG3)	•	•	•	•	•
– Driver's- and front-passenger-side inflatable knee blocker (CGY/CHF)	•	•	•	•	•
– Supplemental front-seat-mounted side (CJ1)	•	•	•	•	•
– Supplemental side-curtain, for outboard passengers in all three rows (CJ5)	•	•	•	•	•
Blind Spot Monitoring (BSM) <sup>(5)</sup> and Rear Cross-Path Detection System <sup>(1)</sup> (XAN)		•	•	•	•
Child Seat Anchor System (LATCH) (CGU)	•	•	•	•	•
Electric Parking Brake (XC4)	•	•	•	•	•

• = Standard. 0 = Optional. P = Available with Package noted. F = Fleet only.

# 2024 CHRYSLER PACIFICA/CHRYSLER PACIFICA PHEV/CHRYSLER VOYAGER

STANDARD FEATURES AND OPTIONS	Voyager	Pacifica Touring	Pacifica Touring L	Pacifica Limited	Pacifica Pinnacle™
CPOS	2DE	2DW	2DL	2DP	2DS

## SAFETY & SECURITY (CONTINUED)

Electronic Stability Control (ESC) <sup>(6)</sup> (BNB)	•	•	•	•	•
FamCAM™ <sup>(27)</sup> – Interior rear-facing camera (included with Uconnect® Theater Family Group and Premium Package) (XPR)			P	P	•
Full-Speed Forward Collision Warning Plus <sup>(8)</sup> (LSU)	•	•	•	•	•
KeySense® (included with Uconnect Theater Family Group and Premium Package) (GX3)			P	P	•
LaneSense® Lane Departure Warning Plus with Lane Keep Assist <sup>(10)</sup> (LAS)		•	•	•	•
Automatic Pedestrian Emergency Braking <sup>(9)</sup> (LST)	•	•	•	•	•
Parallel and Perpendicular Park Assist with Stop <sup>(11)</sup> (included with Safety Sphere Package) (XH5)			P	P	•
ParkSense® Front/Rear Park Assist with Stop <sup>(11)</sup> (included with Safety Sphere Package) (XH4)			P	P	•
ParkSense Rear Park Assist with Stop <sup>(11)</sup> (included with SafetyTec™ Package) (XH3)		•	•	•	
ParkView® Rear Back-Up Camera <sup>(1)</sup> (XAC)	•	•	•	•	
Remote Keyless Entry (GXM)	•	•	•	•	•
Remote Proximity – All doors (GXD)		•	•	•	•
Security Alarm <sup>(24)</sup> (LSA)	•	•	•	•	•
360° Surround-View Camera <sup>(1)</sup> (included with Safety Sphere Package) (XAK)			P	P	•
Tire Pressure Monitoring Display (XGM)	•	•	•	•	•
Trailer Sway Damping <sup>(6)</sup> (packaged with Trailer Tow Group with 3,600-lb Rating; non-Hybrid only) (BNT)				P	P

## PACKAGES/EQUIPMENT GROUPS

18-inch S Appearance Package – Includes Piano Black interior accents, S badge, Anodized Ink badging, Anodized Ice Cave accents, Black daylight opening moldings, premium front fascia upper/lower grilles with Black surround, premium rear fascia, Black Stow N Place® roof rack, 18-inch S Model aluminum wheels and unique S Appearance Package seats (non-Hybrid only) (ADT)			0		
Uconnect Theater Family Group – Includes rear-seat entertainment with Amazon Fire TV® Built-In <sup>(17)</sup> KeySense, interior rear-facing FamCAM <sup>(27)</sup> camera, 115-volt auxiliary power outlet, video remote control, HDMI input, video USB port, two 10-inch seatback touchscreens, video USB port on Touring L and Limited (standard on Pinnacle), 220-amp alternator, Stow 'n Vac integrated vacuum cleaner, heated second-row seats and Blu-ray™/DVD player on Touring L, eight-passenger seating on Front-Wheel Drive (FWD) Touring L, Auto Advance 'n Return front-passenger seat, eight-way power front-passenger seat, hands-free power liftgate, hands-free power-sliding doors, power front and rear one-touch up/down windows, rearview auto-dimming mirror, 13-speaker Alpine® and Uconnect 5 NAV with 10.1-inch display on Touring L, and Blu-ray/DVD player on non-Hybrid, 19-speaker Harman Kardon® with subwoofer on Touring L and power-folding third-row seats on Limited; Pinnacle adds Uconnect Theater with streaming apps (AEZ/AT3)			0	0	•

STANDARD FEATURES AND OPTIONS	Voyager	Pacifica Touring	Pacifica Touring L	Pacifica Limited	Pacifica Pinnacle™
CPOS	2DE	2DW	2DL	2DP	2DS

## PACKAGES/EQUIPMENT GROUPS (CONTINUED)

Safety Sphere – Includes Parallel and Perpendicular Park Assist with Stop <sup>(11)</sup> ParkSense Front/Rear Park Assist with Stop <sup>(11)</sup> and 360° Surround-View Camera <sup>(1)</sup> (restrictions apply) (AAU)			0	0	•
S Appearance Package – Includes Gloss Black mirrors on Limited, Piano Black interior accents, S badge, Anodized Ink badging, Black daylight opening moldings, premium front fascia upper/lower grilles with Black surround, premium rear fascia, unique aluminum S Model wheels, unique S Appearance Package seats on Touring L and Limited, Anodized Ice Cave accents on Touring L, and Black Stow N Place roof rack on Touring and Touring L (restrictions apply) (ADS)		0	0	0	
Trailer Tow Group with 3,600-lb Rating – Includes trailer tow seven-/four-pin wiring harness, 2-inch hitch receiver and Trailer Sway Damping <sup>(6)</sup> and heavy-duty radiator (non-Hybrid only) (AHT)				0	0
Premium Package – Includes passenger-side Auto Advance 'n Return (non-Hybrid), eight-way power front-passenger seat, hands-free power-sliding doors, KeySense, FamCAM <sup>(27)</sup> camera, 115-volt auxiliary power outlet, power front and rear one-touch up/down windows, Alpine 13 speakers, hands-free power liftgate, 220-amp alternator on non-Hybrid, Stow 'n Vac integrated vacuum cleaner on non-Hybrid, heated second-row seats on non-Hybrid and eight-passenger seating on FWD Touring L (not available with Uconnect Theater Family Group) (AC7)			0		
Family Convenience Group – Includes in-vehicle intercom (AAE)					•
Navigation Radio Unavailable – Includes Uconnect 5 with 10.1-inch display (AW8)				0	
Mopar® Roadside Emergency Kit – Includes Toolkit, Reflecting Triangle and First Aid Kit (not available with eight-passenger seating) (ACK)	0	0	0	0	0
Mopar Interior Protection Package A – Includes All-Weather Floor Mats - Stow 'n Go®, Rear Cargo Bin Stow 'n Go Storage, Cargo Area Liner, All-Weather Floor Mats, All-Weather Cargo Floor Mats and Bright Door Sills (restrictions apply) (ACX)	0	0	0	0	
Fleet Security Group – Includes SiriusXM Guardian™ <sup>(14)</sup> trial, Global Telematics Box Module (TBM), 4G LTE Wi-Fi Hotspot <sup>(30)</sup> TomTom® Traffic and Travel Services <sup>(33)</sup> and two additional key fobs	0				
SafetyTec – Includes Advanced Brake Assist; power heated Gloss Black mirrors; 17-inch inflatable spare tire; Uconnect 5 with 10.1-inch Display – Includes 10.1-inch touchscreen, AM/FM, USB host flip, hands-free phone and audio, Android Auto <sup>(3)</sup> Apple CarPlay™ <sup>(4)</sup> and available SiriusXM® with 360L <sup>(13)</sup> (UBG); portable air compressor; Blind Spot Monitoring (BSM) <sup>(5)</sup> and Rear Cross-Path Detection System <sup>(1)</sup> ; inflatable spare tire kit; and ParkSense Rear Park Assist with Stop <sup>(11)</sup>	0				
SafetyTec Plus – Includes 7-inch full-color Thin Film Transistor (TFT) display, rain-sensitive windshield wipers, LaneSense Lane Departure Warning Plus with Lane Keep Assist <sup>(10)</sup> Auto High-Beam Headlamp Control, and Adaptive Cruise Control (ACC) with Stop and Go <sup>(2)</sup>	F				



WV DOT

**3.19.2 Floor Covering:** FR Conversions uses Altro Transflor Wood flooring. A brochure showing samples and colors has been included in this response.

---



Designed for possibilities.  
Made for people.

## Altro Transflor Wood™

**Typical applications:**

**Executive sedans, coach, shuttle, trolley, recreational, specialty vehicles, mobility vehicles, mobile medical units, mobile food, people movers.**

Combining timeless style with contemporary design, Altro Transflor Wood™ has been refreshed to add further visual elegance and practical performance to bus and coach interiors.

Five new additions to the range perfectly complement seven established colors to create an inspiring collection designed to enhance passenger experience.





Offering diverse possibilities to create looks ranging from subtle sophistication to striking contrasts, Altro Transflor Wood can transform vehicles to create unique travel environments.

This freedom of design is backed up by the hard-wearing durability and performance synonymous with Altro transport floors. Vehicle floors not only look great they provide assured slip resistance and comfort under foot. A PUR coating also protects against scuffs and stains to ensure floors maintain their visual appeal even when subjected to the rigorous demands of daily service.

Altro Transflor Wood is a natural choice for those looking to take commuter vehicles in an exciting new direction.

Altro Transport Division 12648 Clark Street Santa Fe Springs, CA 90670

Altro reserves the right to change any information. Please consult [altro.com](http://altro.com) or your local Sales Representative for the latest product range information.

 USA 800.382.0333  CANADA 800.565.4658  [transflor@altro.com](mailto:transflor@altro.com)  [altro.com/transport](http://altro.com/transport)

© Copyright Altro 2022



Oak Traditions  
 FWSA2213F (2.2mm)  
 WR353 / A1M225 / LRV 25



Spiced Bamboo  
 TFWSA2219F (2.2mm)  
 WR342 / A1M224 / LRV 21



Tudor Oak  
 TFWSA2223F (2.2mm)  
 WR471 / A1M337 / LRV



Jacobean Oak  
 TFWSA2222F (2.2mm)  
 WR470/ A1M83 / LRV 11



Seasoned Cherry  
 TFWSA2209F (2.2mm)  
 WR343 / A1M246 / LRV 15



Antique Walnut  
 TFWSA2207F (2.2mm)  
 WR341 / A1M160 / LRV 15



Oak Riche  
 TFWSA2214F (2.2mm)  
 WR227 / A1M227 / LRV 10



Century Oak  
 TFWSA2212F (2.2mm)  
 WR346 / A1M62 / LRV 8



Urban Cherry  
 TFWSA2203F (2.2mm)  
 WR337 / A1M337 / LRV 17



Vintage Cherry  
 TFWSA2202F (2.2mm)  
 WR336 / A1M239 / LRV 22



Manor Oak  
 TFWSA2216F (2.2mm)  
 WR348 / A1M348 / LRV 7



Iron Bamboo  
 FWSA2226F (2.2mm)  
 WR232 / A1M100 / LRV 14

Swatches are printed to show wood grain patterning

### Accent and safety colors

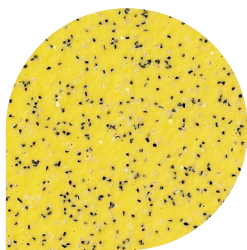

Safety Yellow LRV:46  
 TFM2229 (2.2 mm)  
 TFM2729 (2.7 mm)  
 WR08 / A1M200

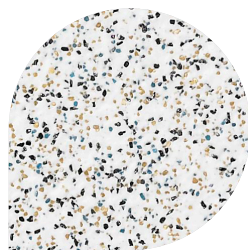

Safety White LRV: 58  
 TFM2200 (2.2 mm)  
 TFM2700 (2.7 mm)  
 WR01 / A1M01

**i** LRV = Light Reflectance Value  
 A1M = Mastic  
 WR = Weld rod

**i** Color matched Weldrods (WR) and Mastics (AM) are available. You'll find their product codes under product SKUs.

**i** All products available in roll and kit format.

 Samples are available if color choice is critical.  
 Contact your rep to request a sample

Dimensions	6'7" x 65'7" / 2 m x 20 m
Thickness	2.2 mm
Weight	4.93 lbs/yd <sup>2</sup>
Format	ROLL and KIT





## WV DOT

**3.22 Seating:** FR Conversions uses the Chrysler Voyager OEM seats for all seats except the double foldaway seat which comes from Freedman Seating. Information on the Freedman 3PT foldaway double seat has been included in this response.

---



**FREEDMAN**  
SEATING COMPANY

**Product Line:** Camper Van / RV, Commercial Bus, Commercial Van

Freedman 3PT Foldaway Mid-Hi



Freedman 3PT Fo

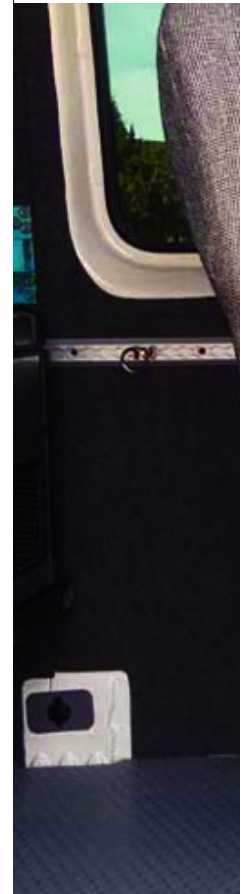

HOME / SEAT ITEMS / COMMERCIAL BUS / /  
3PT SPACESAVER FOLDAWAY

# 3PT SPACESAVER FOLDAWAY

[Privacy & Cookies Policy](#)

[Privacy - Terms](#)

Travel safely in comfort and style with Freedman 3PT seats. The 3PT mid-hi foldaway seats fold up against the vehicle wall, making way for storage or ADAengers. 

### [FMVSS/CMVSS Notice](#)

California residents [see Prop 65 WARNINGS](#).

Freedman Seating Company is an ISO 9001 certified company. We constantly update and improve our products; therefore, we reserve the right to change or modify specifications or materials without notice. All FSC products meet or exceed FMVSS. **All sales are final.**

**CAMPERVAN**  
**SEATING.COM**  
LIVE.WORK.EXPLORE.  
SEATING SOLUTIONS FOR HOWEVER YOU DO IT.



Get Free Quote 

3PT Foldaway Instructions

## Standard Features

- **Meets FMVSS 207/210 and 202a (with 202a headrest)**
- Mid-Hi Back
- Integrated 3 point seat belt (shoulder and lap)
- Conveniently located belts are designed to not fall on the floor
- Knee Saver back for superior hip to knee room
- Contoured seat and back cushion for comfort and support
- Flexolator grid suspension for long lasting seat comfort
- All 3PT seats are designed, built and tested to meet FMVSS 210
- Bolts to most wall and floor track configurations
- Jig welded heavy-duty tubular frames

## Options

[Privacy & Cookies Policy](#)

- CRS-225 hooks and tether



- Your choice of vinyl or cloth
- Integrated wheelchair restraints, call/stop buttons and ADA options
- Vertical stitching
- Flexguard protective shield under the foldaway seat that is added to prevent possible pinch hazards.

## Find Your Local Representative



## RELATED SEATS & PRODUCTS



CONTACT US

Offices throughout North America.

**Find Your Local Representative**

[Privacy & Cookies Policy](#)



**FREEDMAN**<sup>®</sup>  
SEATING COMPANY

COMMERCIAL BUS, DELIVERY TRUCK, DRIVER  
Sport 2.0 Driver Seat

[REQUEST UPHOLSTERY SAMPLES](#)

[SIGN UP FOR OUR NEWSLETTER](#)

AN ISO 9001-2015 REGISTERED COMPANY

*Not just seats — seating solutions.™*



[Privacy & Cookies Policy](#)



**FREEDMAN**<sup>®</sup>  
SEATING COMPANY

©2024  
man  
ing  
any.



COMMERCIAL BUS, DELIVERY TRUCK, DRIVER  
Shield Driver Recliner Seat

[Privacy & Cookies Policy](#)





**FREEDMAN**<sup>®</sup>  
SEATING COMPANY

CAMPER VAN / RV, OPTIONS/ACCESSORIES  
**Foldaway Table**

[Privacy & Cookies Policy](#)





**FREEDMAN**<sup>®</sup>  
SEATING COMPANY

CAMPER VAN / RV, OPTIONS/ACCESSORIES  
**Foldaway Shroud**

[Privacy & Cookies Policy](#)



56658

NOT TO BE USED, DISCLOSED OR REPRODUCED WITHOUT PERMISSION.  
PROPERTY OF THE FREEDMAN SEATING COMPANY.

**NOTES:**

1. IF SEAT DOES NOT LOCK IN PLACE OR THERE IS SIGNIFICANT PLAY, ADJUST THE (2) 3/8-16 BOLTS AT THE END OF THE TRUSS RUNNERS.
2. IF SEAT IS NOT LOCKED IN POSITION, MAY CAUSE DAMAGE AND INJURY.

SEE NOTE 1  
VIEW OF SEAT BOTTOM

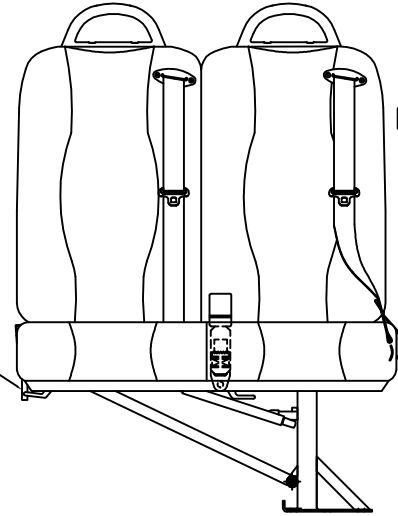
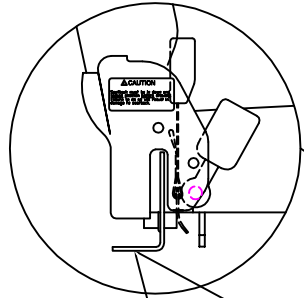
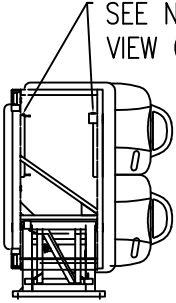

1. PULL LEVER UPWARD
2. FOLD SEAT FORWARD UNTIL IN LOCKED POSITION.
8. PULL LEVER UPWARD TO RAISE SEAT BACK. LIFT UNTIL LOCKED INTO POSITION.

7. PUSH HANDLE TO FOLD DOWN. HOLD SEAT WHILE LOWERING. PUSH DOWN UNTIL IN LOCKED POSITION.

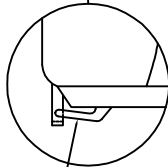
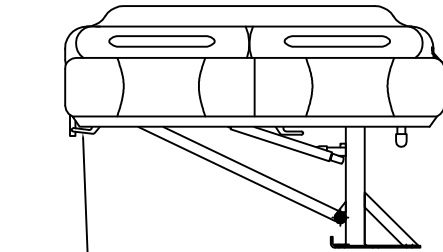

3. PUSH LEVER UPWARD
4. FOLD SEAT TOWARD WALL UNTIL IN LOCKED POSITION.

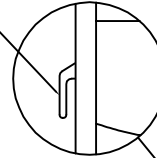

5. ROTATE TRUSS LOCK CLOCKWISE TO LOCK IN PLACE.
6. ROTATE COUNTERCLOCKWISE TO UNLOCK.

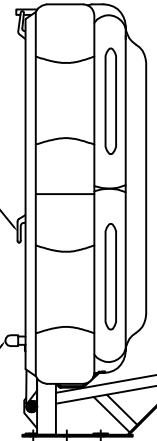

				Tolerance Unless Otherwise Specified				Material:		Freedman Seating Co. 4545 W. Augusta Chicago, IL 60651	
				FRAC. 1/X ±1/32				Specifications:		Part Name INSTRUCTIONS, 3PT FOLDAWAY	
				DECIMAL .XX ±0.02"				Drawn by: RW		Date: 01/17/05	
				ANGULAR ±1°				DO NOT SCALE DRAWING		Drawing No. 56658	
Rev. Level	Description of Change	By	Date	ECN #	Rev. Level	Description of Change	By	Date	ECN #	Rev. Level	Description of Change
					A	RELEASE TO PRODUCTION	RW	1/05	4194		A

DATE:

ORDER NUMBER:



WV DOT

**3.27 Wheelchair Securement System:**

Information on the Q'Straint QRT Max Series system has been included in this response.

---

**3.28 Wheelchair Occupant Restraint System:**

Information on the Q'Straint QRT Max Series system has been included in this response.

# QRT<sup>®</sup>-1 SERIES



**MAX / DELUXE / STANDARD**  
4-POINT SECUREMENT  
WHEELCHAIR RETRACTORS



# QRT<sup>®</sup>-1 SERIES

## The Securement System That Changed Everything

The original 4-point wheelchair securement system, QRT-1 Series retractors defined the way passenger safety devices are designed and tested.

With a range of 3 different options to fit every need and every budget, the QRT-1 Series of retractors offer easy to use, effective 4-Point securement of wheelchairs for virtually any vehicle application.



### QRT MAX

FULLY AUTOMATIC, premium knobless retractor that allows for one-handed operation.



### QRT DELUXE

SELF-LOCKING & SELF-TENSIONING retractor with ergonomic housing and dual tensioning knobs.

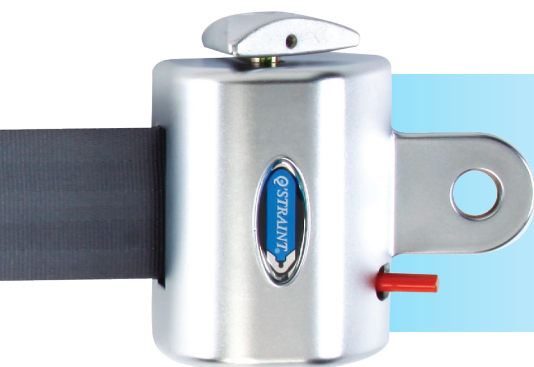

### QRT STANDARD

SEMI-AUTOMATIC retractor that meets all industry standards and specifications.



More than 30 years ago, Q'STRAIT introduced the world's first fully integrated 4-Point wheelchair passenger securement system, now an industry standard the world over.

**The QRT line of retractors are the linchpin of that system.**



Every QRT retractor is fully ADA compliant, and meets or exceeds all standards and regulations, including:

- SAE J2249, ISO 10542,
- FMVSS 209, 302, 210, 222
- CMVSS 209
- CSA Z605
- and 30mph/20g crash testing

### Anchorage Options

All QRT-1 Series Retractors are compatible with L-Track, L-Pockets and Slide 'N Click anchorages, or may be directly mounted to vehicle floors, seat legs or barriers.



#### L-TRACK / L-POCKETS

For kits that use L-Track or L-Pocket anchorages, QRT Series retractors feature our patented Positive Lock Indicator (PLI) that clearly indicates when the fitting is locked in the anchorage.

#### SLIDE 'N CLICK

For kits that include Slide 'N Click anchorages, QRT Series retractors feature a single-bolt SNC assembly and plunger that allows a full 360° rotation, eliminating anchorage alignment guesswork.

## QRT-1 SERIES FEATURES COMPARISON

	MAX	DLX	STD	
<b>Knobless, One-Handed Operation.</b> No knobs to interfere with wheels and footrests.	●			
<b>Dual Tensioning Knobs.</b> Provides additional tensioning if needed.		●		
<b>Single Tensioning Knob.</b> Provides additional tensioning if needed.			●	
<b>Automatic, Self-Locking.</b> Allows easy, one-handed hook-up.	●	●		
<b>Self-Tensioning.</b> Retractors automatically take up 'slack'.	●	●		
<b>Positive Lock Indicator.</b> Patented feature clearly indicates when fitting is locked in anchorage.	●	●	●	
<b>Interchangeable.</b> Eliminates confusion: no right, left, front or rear locations.	●	●	●	
<b>Low Profile &amp; Compact.</b> Elimination of mounting bracket allows retractors to fit under most footrests.	●	●	●	
<b>Accommodates Larger Wheelchairs.</b> Reduced overall length leaves more room for wheelchairs.	●	●		
<b>Ultra-Durable.</b> Hardened steel and coated zinc for maximum corrosion resistance.	●	●	●	
<b>Universal Design.</b> Accommodates virtually all wheelchair designs, including scooters.	●	●	●	
<b>J-Hook.</b> Reduces twisting of belts and ensures proper securement for all wheelchair designs.	●	●	●	
<b>Foot Release Lever.</b> Easy release eliminates the stress of bending down.	●	●	●	



[WWW.QSTRAINT.COM/QRT-1-SERIES](http://WWW.QSTRAINT.COM/QRT-1-SERIES)

© 2017 Q'STRAIT®. All Rights Reserved.  
Q'STRAIT®, Q'STRAIT® logo, QRT-SERIES® and QRT™ are registered trademarks of Q'STRAIT®, Inc.

**Q'STRAIT EUROPE**

72-76 John Wilson Business Park  
Whitstable, Kent, CT5 3QT  
United Kingdom  
Tel: +44 (0)1227 773035  
Fax: +44 (0)1227 770035  
Email: [info@qstraint.co.uk](mailto:info@qstraint.co.uk)

**Q'STRAIT AMERICA**

4031 NE 12th Terrace  
Oakland Park, FL 33334  
Tel: 800-987-9987  
Fax: 954-986-0021  
Email: [qstraint@qstraint.com](mailto:qstraint@qstraint.com)

**Q'STRAIT AUSTRALIA**

Tramanco Pty Ltd.  
21 Shoebury Street,  
Rocklea, Australia, QLD. 4106  
Tel: +61 7 3892 2311  
Fax: +61 7 3892 1819  
Email: [info@tramanco.com.au](mailto:info@tramanco.com.au)



WV DOT

**3.35 Training:** A letter of understanding of the terms in this Section has been included in this response.

---



Proven Quality.  
Trusted Name.

Transportation Equipment Sales Corporation

## 3.35 Training

TESCO understands the training requirements set forth in section 3.36 of the WVDOT specifications. TESCO and/or FR Conversions will have a trainer available to provide up to two days training at two different locations in the state.



WV DOT

**3.31.5 Security Camera:** The Angeltrax 6 camera system documentation has been included in this response.

---



**PREPARED FOR:**

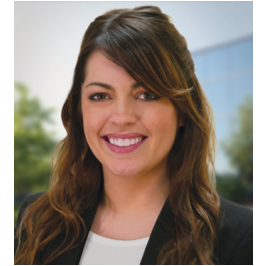

**PREPARED BY:  
Laci Hatley**



Mid-Atlantic Sales Executive  
 119 South Woodburn Drive  
 Dothan, AL 36305  
 Cell: 803.414.3035  
 Corporate Office: 1.800.673.1788  
 laci.hatley@angeltrax.com





BILLING DETAILS	SHIPPING DETAILS
Tesco Bus Sales Jeff Pappas West Virginia DOT  6402 Seaman Rd. Oregon, OH 43616 USA  419-836-2835 jpappas@tescobus.com	Tesco Bus Sales Jeff Pappas West Virginia DOT  6402 Seaman Rd. Oregon, OH 43616 USA  419-836-2835 jpappas@tescobus.com

**PRODUCTS**

MODEL & DESCRIPTION	QTY		
AngelTrax VULCANV1284HC Mobile Digital Video Recorder System (System Contents and Product Descriptions Listed Below)	1		
 <p><b>V1284HC</b>            Vulcan Series 12-Channel HD/IP Mobile Digital Video Recorder</p> <ul style="list-style-type: none"> <li>• 12 Channels with 8 Channels D1, WD1, 720P, or up to 1080P + 4 Channels IP 720P, 1080P, up to 4MP</li> <li>• Patented Hybrid Component Modular Design</li> <li>• Supports 3.5-Inch Platter Hard Drive (Sold Separately)</li> <li>• 64GB SD Card for Redundant Recording</li> <li>• Built-in Wi-Fi Module</li> <li>• Built-in G-Force Sensor</li> <li>• Vandal-Resistant Locking Hard Drive</li> <li>• Panic Button</li> <li>• H.264/H.265 Compression</li> </ul>	1		
 <p><b>SSD1TBM2</b>            Solid State 1TB M.2 SATA Hard Drive for 3.5" Tray            REQUIRES PURCHASE OF HARD DRIVE TRAY</p> <p>We recommend the use of storage media provided only by AngelTrax for our recording devices. AngelTrax hard drives and SD cards are optimized for around-the-clock video surveillance and are designed to withstand extreme temperatures. Standard hard drives and SD cards purchased through consumer resellers are not made for surveillance devices and have been known to stop functioning at any time without warning, causing a loss of video.</p>	1		
 <p><b>MSD512GB</b>            512GB microSD Solid-State Memory Card</p> <p>We recommend the use of storage media provided only by AngelTrax for our recording devices. AngelTrax hard drives, and SD cards are optimized for around-the-clock video surveillance and are designed to withstand extreme temperatures. Standard hard drives and SD cards purchased through consumer resellers are not made for surveillance devices and have been known to stop functioning at any time without warning, causing a loss of video.</p>	1		

PRODUCTS

MODEL & DESCRIPTION	QTY		
 <p><b>VULPBH</b> Vulcan Series Panic Button Housing PC color</p>	1		
 <p><b>HD1700V</b> (3) Vulcan Series 170-Degree HD 1080P Low Profile Camera: Overhang facing towards the rear, Above the drivers left shoulder facing the door, Above the driver, to see the drivers operations  <ul style="list-style-type: none"> <li>• 1.7mm Lens with Fully Articulating Lens Casing, Adjustable Vertically and Horizontally at Installation</li> <li>• IP68 Rated Waterproof Interior/Exterior Camera</li> <li>• 1080P HD</li> <li>• 2.12 Megapixels</li> <li>• Noise-Gated Microphone</li> <li>• Vandal-Resistant Casing</li> <li>• Scratch-Resistant, Anti-Glare Glass Lens Cover</li> <li>• Infrared</li> </ul> </p>	3		
 <p><b>HD2500V</b> Vulcan Series 2500 HD Low Profile Camera: Facing the wheelchair lift  <ul style="list-style-type: none"> <li>• 2.5mm Lens with Fully Articulating Lens Casing, Adjustable Vertically and Horizontally at Installation</li> <li>• IP68 Rated Waterproof Interior/Exterior Camera</li> <li>• 1080P HD</li> <li>• 3 Megapixels</li> <li>• Noise-Gated Microphone</li> <li>• Vandal-Resistant Casing</li> <li>• Scratch-Resistant, Anti-Glare Glass Lens Cover</li> <li>• Infrared</li> </ul> </p>	1		
 <p><b>HD2500WS</b> Vulcan Series 2500 HD Windshield Camera: Out the Windshield  <ul style="list-style-type: none"> <li>• 2.5mm Lens with Fully Articulating Lens Casing, Adjustable Vertically and Horizontally at Installation</li> <li>• 1080P HD</li> <li>• 2.13 Megapixels</li> <li>• Noise-Gated Microphone</li> <li>• Vandal-Resistant Casing</li> <li>• Scratch-Resistant, Anti-Glare Glass Lens Cover</li> <li>• Starlight CMOS Sensor for Exceptional Sensitivity to Starlight</li> <li>• Mounted to Ceiling of Vehicle Using ADJBRWS Bracket for View Through Windshield (Bracket Sold Separately)</li> </ul> </p>	1		
 <p><b>HD3600V</b> Vulcan Series 3600 HD Low Profile Camera: Rear of the bus  <ul style="list-style-type: none"> <li>• 3.6mm Lens with Fully Articulating Lens Casing, Adjustable Vertically and Horizontally at Installation</li> <li>• IP68 Rated Waterproof Interior/Exterior Camera</li> <li>• 1080P HD</li> <li>• 3 Megapixels</li> <li>• Noise-Gated Microphone</li> <li>• Vandal-Resistant Casing</li> <li>• Scratch-Resistant, Anti-Glare Glass Lens Cover</li> <li>• Infrared</li> <li>• For use in school bus SAV applications as overview camera when equipped with YELHS1 yellow housing</li> </ul> </p>	1		
 <p><b>HD4CBL</b> 13.12 ft. HD Camera Cable</p>	1		

PRODUCTS			
MODEL & DESCRIPTION		QTY	
 <p><b>HD9CBL</b> (4) 29.53 ft. HD Camera Cable</p>		4	
 <p><b>HD18CBL</b> 59.06 ft. HD Camera Cable</p>		1	
 <p><b>ADJBRWS</b> Adjustable Mounting Bracket for Vulcan Series HD-WS Starlight Camera Capturing Windshield View</p>		1	
 <p><b>WC4G</b> Vulcan Series Wi-Fi Cellular GPS Tri-Mode Antenna • Wi-Fi, Cellular and Passive GPS Antenna • Interior-mounted</p>		1	
 <p><b>VULPWRKEY</b> Security Key USB 3.0 for Hard Drive Version Vulcan Series MNVRs, MDVRs</p>		1	
<p><b>CONT3RD</b> Installation not included. Installation to be performed by Dealer or End User as specified by Dealer.</p>		1	
<p><b>SHIPPING/HANDLING</b> Shipping and Handling Charges - 1 Bx * Optional items are not included in the calculation.*</p>		1	



Proven Quality. Trusted Name.

## WVDOT

**5.9.1 Warranty on complete vehicle:** Warranty information on the Chrysler Voyager and FR Conversions upfit has been included in this response.

---

**5.9.2 Warranty on Basic Vehicle Structure:**

Warranty information on the Chrysler Voyager and FR Conversions upfit has been included in this response.

---

**5.9.4 Warranties to be provided on subsystems and components:** Warranty information has been included in this response.



Proven Quality.  
Trusted Name.

Transportation Equipment Sales Corporation

## Warranty and Maintenance Support

Following this document is specific information on vehicle warranty.

TESCO has a customer service department dedicated to resolving our customer's warranty and service issues. TESCO employs two customer service representatives. If a customer has a warranty issue, we ask them to call our toll-free number before taking the vehicle to a service facility. All vehicles will be delivered with a document stating the warranty procedure. A copy of this document has been provided in this proposal. Our customer service team will quickly direct them to the proper service facility based on the uniqueness of the issue. If our customer has a particular service facility that they prefer, our customer service department will try to ensure that the customer can use that service facility as long as the equipment manufacturer will allow it. This also applies to customers that have their own in-house service department.

When warranty related service is performed for any non-chassis issue, the service facility will bill TESCO directly and TESCO will reimburse the facility. For Chrysler chassis related issues, the Chrysler dealer will bill the OEM directly.

If there is a non-warranty service question, TESCO can still assist with locating a service facility in the same manner as warrantied service.

TESCO uses a tracking system linked to our ERP software to manage warranty issues. This ensures that each and every issue is handled quickly, and professionally. All notes regarding the issue are entered into this system so that all TESCO employees can be up to speed on the situation in seconds. The issues remain open on the system until the customer has stated they are satisfied. The TESCO management receives regular reports on outstanding issues to ensure the customer needs are met.

In the unlikely event of a series of warranty issues, TESCO has the ability to send our own or the factory technicians to solve the problem.

Included in this proposal is a list of recommended service facilities in or near your area.

# Warranty



FR Conversions Inc. to provide Bumper to Bumper parts and labor warranty for any mechanical defect relating to this vehicle for 30 days from the date of delivery or 1,000 miles; whichever is less. In the event of an alleged claim during the warranty period, the original owner should contact FR Conversions Inc. to obtain information with respect to warranty service. *Any work done without prior approval may not be covered.*

FR Conversions Inc. to provide a limited warranty on its modification of wheelchair accessible vans. FR Conversions Inc. warrants that its modification is free from defects in material and workmanship according to the terms herein. This limited warranty commences on the day the vehicle is delivered to the original owner of the modified vehicle. FR Conversions Inc. warrants that it will repair or replace, free of charge, any proven defect of its modification of an FR Conversions Inc. vehicle for a term of three (3) years from the date of purchase or thirty-six thousand (36,000) miles beyond the odometer reading as of the date the FR Conversions Inc. vehicle is delivered to the original owner; whichever occurs first. This limited warranty only applies to a defect of an FR Conversions Inc. modification that occurs under normal conditions of use and service, proves to be a defect in material or workmanship, becomes apparent while the original owner of the FR Conversions Inc. vehicle remains the owner of the FR Conversions Inc. vehicle and impairs functionality of the modification. In the event of an alleged defect in the modification during the warranty period, the original owner should contact FR Conversions Inc. to obtain information with respect to warranty service. *Any work done without prior approval may not be covered.* For modified vehicles only: *This vehicle has been modified in compliance with 49 CFR 595.6 and is in compliance with all federal motor vehicle safety standards in effect at the time of its original manufacture.*

***ALL IMPLIED WARRANTIES, INCLUDING THE IMPLIED WARRANTIES OF MERCHANTABILITY AND FITNESS FOR A PARTICULAR PURPOSE, ARE HEREBY LIMITED TO THE SAME DURATION OF TIME AS THE EXPRESS WRITTEN WARRANTY ABOVE STATED. SOME STATES DO NOT ALLOW LIMITATIONS ON HOW LONG AN IMPLIED WARRANTY LASTS, SO THE ABOVE LIMITATIONS MAY NOT APPLY TO YOU. ORIGINAL OWNER SHALL NOT BE ENTITLED TO RECOVER FROM FR CONVERSIONS INC. ANY CONSEQUENTIAL DAMAGES, DAMAGES TO PROPERTY, DAMAGES FOR LOSS OF USE, LOSS OF TIME, LOSS OF PROFITS, OR INCOME, OR ANY OTHER INCIDENTAL DAMAGES, SOME STATES DO NOT ALLOW THE EXCLUSION OR LIMITATION OF INCIDENTAL OR CONSEQUENTIAL DAMAGES, SO THE ABOVE LIMITATIONS MAY NOT APPLY TO YOU.***

Vin# -----

\_\_\_\_\_  
Corporation Representative

**FCA Fleet Powertrain Care**  
**5 Year / 100,000 Mile Limited Warranty Extension**  
**(\$0 Deductible)**

THIS LIMITED WARRANTY IS PROVIDED TO OWNERS of a 2016 through 2024 Model Year Chrysler, Dodge, Jeep and Ram vehicles (excluding vehicles equipped with diesel engines) who purchased it through FCA US LLC specifically for Fleet Government Bid/Leases and Fleet Commercial/ Lease orders only.

**YOUR LEGAL RIGHTS UNDER THIS LIMITED WARRANTY**

This warranty is the express warranty FCA US LLC ("FCA") makes for your vehicle. This warranty gives you specific legal rights. You may also have other rights that vary from state to state. For example, you may have some implied warranties, depending on the state where your vehicle was sold or is registered.

**These implied warranties are limited, to the extent allowed by law, to the time periods covered by this express written warranty.**

If you use your vehicle primarily for business or commercial purposes, then these implied warranties do not apply and FCA completely disclaims them to the extent allowed by law. And the implied warranty of fitness for a particular purpose does not apply if your vehicle is used for racing, even if the vehicle is equipped for racing.

**Some states do not allow limitations on how long an implied warranty lasts, so the above limitations may not apply to you.**

**Incidental and Consequential Damages Not Covered**

**Your warranty does not cover any incidental or consequential damages connected with your vehicle's failure, either while under warranty or afterward.** Examples of such damages include: (a) lost time; (b) inconvenience; (c) the loss of the use of your vehicle; (d) the cost of rental vehicles, gasoline, telephone, travel, or lodging; (e) the loss of personal or commercial property; and (f) the loss of revenue.

**Some states don't allow incidental or consequential damages to be excluded or limited, so this exclusion may not apply to you.**

**Persons to Whom the Limited Warranty is Offered**

This Limited Warranty is provided to owners of a 2016 through 2024 Model Year Chrysler, Dodge, Jeep and Ram vehicles (excluding vehicles equipped with diesel engines) who purchased it through FCA US LLC specifically for Fleet Government Bid/Leases and Fleet Commercial/ Lease orders only.

**What This Limited Warranty Extension Covers**

This Powertrain Limited Warranty is a part of your New Vehicle Limited Warranty. It extends the 5 year or 60,000-mile powertrain limited warranty on mechanical components of the vehicle to 5 years from the in service date of the vehicle or 100,000 miles on the odometer, whichever comes first. It covers the cost of all parts and labor needed to repair a powertrain component listed below that is defective in workmanship and materials

Please keep this letter in your glove box along with your vehicle's other warranty information for future reference if necessary. All the other terms and conditions and the "What's Not Covered" items of your warranty remain the same as stated in your Warranty Information book.

**Parts Covered**

**The Powertrain Limited Warranty covers these parts and components of your vehicle's powertrain supplied by FCA US LLC**

**Gasoline Engine:** Cylinder Block and all Internal Parts; Cylinder Head Assemblies; Timing Case, Timing Chain, Timing Belt, Gears and Sprockets; Vibration Damper; Oil Pump, Water Pump and Housing; Intake and Exhaust Manifolds; Flywheel with Starter Ring Gear; Core Plugs; Valve Covers; Oil Pan; Turbocharger Housing and Internal Parts; Turbocharger Wastegate Actuator; Supercharger; Serpentine Belt Tensioner; Seals and Gaskets for listed components only.

**Transmission:** Transmission Case and all Internal Parts; Torque Converter; Drive/Flex Plate; Transmission Range Switch; Speed Sensors; Pressure Sensors; Transmission Control Module; Bell Housing; Oil Pan; Seals and Gaskets for listed components only.  
**NOTE: MANUAL TRANSMISSION CLUTCH PARTS ARE NOT COVERED AT ANY TIME.**

**Front Wheel Drive:** Transaxle Case and all Internal Parts; Axle Shaft Assemblies; Constant Velocity Joints and Boots; Differential Cover; Oil Pan; Transaxle Speed Sensors; Transaxle Solenoid Assembly; PRNDL Position Switch; Transaxle Electronic Controller; Torque Converter; Seals and Gaskets for listed components only.  
**NOTE: MANUAL TRANSMISSION CLUTCH PARTS ARE NOT COVERED AT ANY TIME.**

**All-Wheel Drive (AWD):** Power Transfer Unit and all Internal Parts; Viscous Coupler; Axle Housing and all Internal Parts; Constant Velocity Joints and Boots; Drive Shaft and Axle Shaft Assemblies; Differential Carrier Assembly and all Internal Parts; Output Ball Bearing; Output Flange; End Cover; Overrunning Clutch; Vacuum Motor; Torque Tube; Pinion Spacer and Shim; Seals and Gaskets for listed components only.

**Rear Wheel Drive:** Rear Axle Housing and all Internal Parts; Axle Shafts; Axle Shaft Bearings; Drive Shaft Assemblies; Drive Shaft Center Bearings; Universal Joints and Yokes; Seals and Gaskets for listed components only.

**Four-Wheel Drive (4x4):** Transfer Case and all Internal Parts; transfer case control module and shift mode motor assembly Axle Housing and all Internal Parts; Axles Shafts; Axle Shaft Bearings; Drive Shafts Assemblies (Front and Rear); Drive Shaft Center Bearings; Universal Joints and Yokes; Disconnect Housing Assembly; Seals and Gaskets for the listed components only.

**HOW TO GET WARRANTY SERVICE**

**Where to Take Your Vehicle**

In the United States (We Include U.S. Possessions and Territories as Part of the United States for Warranty Purposes): Warranty service must be done by an authorized Chrysler, Dodge, Jeep or Ram dealer. We strongly recommend that you take your vehicle to your Selling Dealer. They know you and your vehicle best, and are most concerned that you get prompt and high quality service. If you move within the United States, warranty service may be requested from any authorized Chrysler, Dodge, Jeep or Ram dealer.

In Canada and Mexico: If you are traveling temporarily in Canada or Mexico, and your vehicle remains registered in the United States, your FCA US warranty still applies. Service may be requested at any authorized Chrysler, Dodge, Jeep or Ram dealership.

**WHAT IS NOT COVERED UNDER THIS FCA US LLC LIMITED WARRANTY**

**Some Modifications Don't Void the Warranty But Aren't Covered**

Certain changes that you might make to your vehicle do not, by themselves, void this warranty. Examples of some of these changes are: (a) installing non-FCA US LLC ("FCA") parts, components, or equipment (such as a non-FCA radio or speed control); and (b) using special non-FCA materials or additives.

But your warranty does not cover any part that was not on your vehicle when it left the manufacturing plant or is not certified for use on your vehicle. Nor does it cover the costs of any repairs or adjustments that might be caused or needed because of the installation or use of non-FCA parts, components, equipment, materials, or additives.

Performance or racing parts are considered to be non-FCA parts. Repairs or adjustments caused by their use are not covered under your warranty. Examples of the types of alterations not covered are: (a) installing accessories - except for genuine FCA / MOPAR accessories installed by an authorized Chrysler, Dodge, Jeep or Ram dealer; (b)

**FCA Fleet Powertrain Care**  
**5 Year / 100,000 Mile Limited Warranty Extension**  
**(\$0 Deductible)**

---

applying rustproofing or other protection products; (c) changing the vehicle's configuration or dimensions, such as converting the vehicle into a limousine or food service vehicle; or (d) using any refrigerant that FCA has not approved.

**Environmental Factors Not Covered**

Your warranty does not cover damage caused by environmental factors such as airborne fallout, bird droppings, insect damage, chemicals, tree sap, salt, ocean spray, acid rain, and road hazards. Nor does your warranty cover damage caused by hailstorms, windstorms, tornadoes, sandstorms, lightning, floods, and earthquakes.

Your warranty does not cover conditions resulting from anything impacting the vehicle. This includes cracks and chips in glass, scratches and chips in painted surfaces, or damage from collision.

**Maintenance Costs Not Covered**

Your warranty does not cover the costs of repairing damage caused by poor or improper maintenance. Nor does it cover damage caused by the use of contaminated fuels, or by the use of fuels, oils, lubricants, cleaners or fluids other than those recommended in your Owner's Manual.

The warranty does not cover the costs of your vehicle's normal or scheduled maintenance - the parts and services that all vehicles routinely need. Some of these parts and services, which your warranty does cover, include: (a) lubrication; (b) engine tune-ups; (c) replacing filters, coolant, spark plugs, bulbs, or fuses (unless those costs result from a covered repair); (d) cleaning and polishing; and (e) replacing worn wiper blades, worn brake pads and linings, or clutch linings.

**Racing Not Covered**

Your warranty does not cover the costs of repairing damage or conditions caused by racing, nor does it cover the repair of any defects that are found as the result of participating in a racing event.

**Certain Kinds of Corrosion Not Covered**

Your warranty does not cover the following: (a) corrosion caused by accident, damage, abuse, or vehicle alteration; (b) surface corrosion caused by such things as industrial fallout, sand, salt, hail, ocean spray, and stones; (c) corrosion caused by the extensive or abnormal transport of caustic materials like chemicals, acids, and fertilizers; and (d) corrosion of special bodies, body conversions, or equipment that was not on your vehicle when it left the manufacturing plant or was not supplied by FCA.

**Other Exclusions**

Your warranty does not cover the costs of repairing damage or conditions caused by any of the following: (a) fire or accident; (b) abuse or negligence; (c) misuse - for example, driving over curbs or overloading; (d) tampering with the emission systems, or with a part that could affect the emission systems; (e) use of used parts, even if they were originally supplied by FCA (however, authorized FCA / MOPAR remanufactured parts are covered); (f) windshield or rear window damage from external objects; (g) any changes made to your vehicle that don't comply with FCA; or (h) using any fluid that doesn't meet the minimum recommendations in your Owner's Manual.

**Total Loss, Salvage, Junk, or Scrap Vehicles Not Covered**

A vehicle has no warranty coverage of any kind if: (a) the vehicle is declared to be a total loss by an insurance company; (b) the vehicle is rebuilt after being declared to be a total loss by an insurance company; or (c) the vehicle is issued a certificate of title indicating that it is designated as "salvage," "junk," "rebuilt," "scrap," or some similar word.

FCA will deny warranty coverage without notice if it learns that a vehicle is ineligible for coverage for any of these reasons.

**Restricted Warranty**

Your warranty can also be restricted by FCA. FCA may restrict the warranty on your vehicle if the vehicle is not properly maintained, or if the vehicle is abused or neglected, and the abuse or neglect interferes with the proper functioning of the vehicle. If the warranty is restricted, coverage may be denied or subject to approval by FCA before covered repairs are performed.

**Registration and Operation Requirements**

This Limited Warranty covers your vehicle only if: (a) it is registered in the U.S.; (b) it is driven mainly in the U.S. or Canada, and (c) it is operated and maintained in the manner described in your Owner's Manual.

There is no Limited Warranty coverage on your Vehicle if it is sold, registered or operated, other than temporarily, by you, outside of the United States (including the 50 states, the District of Columbia, Puerto Rico, or Guam).

**Other Terms of These Limited Warranties**

Punitive, exemplary or multiple damages may not be recovered unless applicable state or local law prohibits this disclaimer. No person, including FCA US LLC employees or dealers, may modify or waive any part of this Limited Warranty.

**General Information**

It's your responsibility to properly maintain and operate your new vehicle. Follow the instructions contained in the General and Scheduled Maintenance Service guidelines in your Owner's Manual. Regular, scheduled maintenance is essential to trouble-free operation. If there is a dispute between you and FCA US concerning your maintenance of your vehicle, FCA US will require you to provide proof that your vehicle was properly maintained.



Proven Quality.  
Trusted Name.

Transportation Equipment Sales Corporation

<u>Service Facilities</u>	<u>Address</u>	<u>City &amp; ST</u>	<u>Zip</u>
<b>RAM Chassis / Body / AC:</b>			
Northside Chrysler Dodge Jeep Ram	812 Northside Dr.	Summersville, WV.	26651
Dutch Miller Chrysler Dodge Jeep Ram	339 Maccorkle Ave. SW	South Charleston, WV.	25303
Dutch Miller Chrysler Dodge Jeep Ram	435 Church St. S	Ripley, WV.	25271
H And M Motor Company	373 East Third Street	Weston, WV.	26452
Sheets Chrysler Dodge Jeep Ram	250 Auto Plaza Dr.	Beckley, WV.	25801
Stephens Auto Center	104 Stephens Dr.	Danville, WV.	25053
Walker Chrysler Dodge Jeep Ram	102 Orchard Park Rd.	Hurricane, WV.	25526
Astorg Chrysler Dodge Jeep Ram FIAT	1501 7th St.	Parkers, WV.	26101
Greenbrier Motor Co. Inc.	111 Seneca Trail	Lewisburg, WV.	24901
Country Club Chrysler Dodge Jeep Ram	Route 19 South	Clarksburg, WV.	26301
Elkins Chrysler Dodge Jeep Ram	1434 Beverly Pike	Elkins, WV.	26241
Thornhill Chrysler Dodge Jeep Ram	500 Stratton Street	Logan, WV.	25601
Goldy Chrysler Dodge Jeep Ram	187 Kinetic Dr.	Huntington, WV.	25701
Urse Dodge-Chry-Jeep	14 Tygart Mall Loop	White Hall, WV.	26554
Elm Grove Chrysler Dodge Jeep Ram	2538 National Rd.	Wheeling WV.	26003
Straub Chrysler Dodge Jeep Ram	1502 Wheeling Ave.	Glen Dale, WV.	26038
Hancock County Chrysler Dodge Jeep Ram	845Washington Street	Newell, WV.	26050

<u>Phone</u>
--------------

(304) 872-9011
----------------

(304) 343-7700
----------------

(304) 884-0327
----------------

(304) 269-5727
----------------

(304) 252-4555
----------------

(304) 369-2411
----------------

(304) 562-9011
----------------

(800) 227-8674
----------------

(304) 645-1010
----------------

(304) 624-7611
----------------

(304) 636-2222
----------------

(304) 896-9900
----------------

(304) 781-0555
----------------

(304) 363-9300
----------------

(833) 917-1438
----------------

(304) 845-6750
----------------

(304) 387-3100
----------------



WVDOT

**10.2 H. Conversion Location:** The van final assembly is located at FR Conversions, 1231 Tech Ct, Westminster MD 21157.

---



WVDOT

**10.2 I. References:** A list of five (5) users names, addresses, emails and telephone numbers who have been provided similar equipment by the Vendor has been included in this response.

---



Proven Quality.  
Trusted Name.

Transportation Equipment Sales Corporation

## REFERENCES FOR SIMILAR PROJECTS

### City of Baraboo

Julie Ostrander  
101 South Boulevard  
Baraboo, WI 53913  
608-355-7338

[jostrander@cityofbaraboo.com](mailto:jostrander@cityofbaraboo.com)

TESCO provided rear entry Chrysler ADA vans to the City of Baraboo.

### Jefferson County

Michael Hanson  
311 South Center Avenue  
Jefferson, WI 53549  
920-674-8139

[michaelh@jeffersoncountywi.gov](mailto:michaelh@jeffersoncountywi.gov)

TESCO provided rear entry Chrysler ADA vans to Jefferson County

### City of Portage

Jennifer Becker  
115 W. Pleasant Street  
Portage, WI 53901  
608-742-2176

[jennifer.becker@portagewi.gov](mailto:jennifer.becker@portagewi.gov)

TESCO provided rear entry Chrysler ADA vans to the City of Portage.

### County of Calumet

Joann Dewhurst  
206 Court Street  
Chilton, WI 53014  
920-849-1451

[Joann.dewhurst@calumetcounty.org](mailto:Joann.dewhurst@calumetcounty.org)

TESCO provided rear entry Chrysler ADA vans to The County of Calumet.

### The City of Mauston

Val Nelson  
303 Mansion Street  
Mauston, WI 53948  
608-847-4040

[valnelson@mauston.com](mailto:valnelson@mauston.com)

TESCO provided rear entry Chrysler ADA vans to The City of Mauston.

**Confidential Document:** The information provided on this document shall not be duplicated, used or disclosed in whole or in part, for any purpose other than to evaluate this bid.

**REQUEST FOR QUOTATION  
ADA LOWERED FLOOR MINIVANS**

**EXHIBIT A PRICING PAGE - Transportation Equipment Sales Corporation (TESCO)**

<b>Class</b>	<b>Vehicle Description</b>	<b>Unit Price Per Vehicle</b>	<b>Estimated Quantity</b>	<b>Extended Price</b>
<b>A</b>	Vehicle, One wheelchair Position, White, No Stripes or Logos, Stowaway Ramp Under Floor	NO BID	10	NO BID
<b>B</b>	Vehicle, One Wheelchair Position, White, No Stripes or Logos, Foldaway Ramp	\$82,886.00	1	\$82,886.00

<b>TOTAL BID EVALUATION</b>	<b>\$82,886.00</b>
-----------------------------	--------------------

**Complete form provided**

**Please note these are only estimated quantities and do not reflect any guarantee of purchase**

**The DMT may purchase more or less as needed.**

**Please do not alter Pricing Page**



WV DOT

Final\_CRFQ\_0810\_DMT2400000006\_4\_WV\_CR  
FQ\_FORM

---

REQUEST FOR QUOTATION  
ADA Compliant Lowered Floor Mini-Van

---

**BID FORM #3**

**DISADVANTAGED BUSINESS ENTERPRISE  
VENDORS/ MANUFACTURERS CERTIFICATION**

**REQUIRED BID FOR TO BE SUBMITTED WITH BID**

(Check appropriate statement)

The Vendor, if a transit vehicle manufacturer, hereby certifies that it has complied with the requirements of 49 CFR Section 26.49 by submitting an annual DBE goal to the Federal Transit Administration (FTA). The goal has either been approved or not disapproved by FTA.

The Vendor, if a non-manufacturing supplier, hereby certifies that the manufacturer of the transit vehicle to be supplied has complied with the above-referenced requirement of 49 CFR Section 26.49.

5/29/2024  
Date

*Alicia Jan*  
Authorized Signature

COO  
Title

FR conversions, LLC  
Company Name

**REQUEST FOR QUOTATION  
ADA Compliant Lowered Floor Mini-Van**

---

**BID FORM #4**

**BUY AMERICA CERTIFICATION  
ROLLING STOCK  
REQUIRED BID FOR TO BE SUBMITTED WITH BID**

**Certificate of Compliance**

The bidder or offeror hereby certifies that it will comply with the requirements of section 165(b) (3), of the Surface Transportation Assistance Act of 1982, as amended, and the applicable regulations of 49 CFR 661.11:

5/29/2024  
Date

*Tricia Terr*  
Authorized Signature

FR Conversions, LLC  
Company Name

Tricia Terr  
Name

COO  
Title

**Certificate for Non-Compliance**

The bidder or offeror hereby certifies that it cannot comply with the requirements of section 165(b) (3) of the Surface Transportation Assistance Act of 1982, as amended, but may qualify for an exception to the requirement consistent with section 165(b) (2) or (b) (4) of the Surface Transportation Assistance Act, as amended, and the applicable regulations in 49 CFR 661.7.

\_\_\_\_\_  
Date

\_\_\_\_\_  
Authorized Signature

\_\_\_\_\_  
Company Name

\_\_\_\_\_  
Name

\_\_\_\_\_  
Title

REQUEST FOR QUOTATION  
ADA Compliant Lowered Floor Mini-Van

---

**BID FORM #5**

**FEDERAL MOTOR VEHICLE  
SAFETY STANDARDS CERTIFICATION**

**REQUIRED BID FORM TO BE SUBMITTED WITH BID**

The vendor hereby certifies that it shall submit, as required by Title 49 of the CFR, Part 663 - Subpart D, it's self-certification information stating that the vehicle(s) will comply with the relevant Federal Motor Vehicle Safety Standards issued by the National Highway Traffic Safety Administration in Title 49 of the Code of Federal Regulations, Part 571.

5/29/2024

Date

*Laura Jan*

Authorized Signature

COO

Title

FR Conversions, LLC

Company Name



WVDOT

ADDENDUM NO\_1 CRFQ DMT2400000006

---



Department of Administration  
 Purchasing Division  
 2019 Washington Street East  
 Post Office Box 50130  
 Charleston, WV 25305-0130

State of West Virginia  
 Centralized Request for Quote  
 Vehicles

<b>Proc Folder:</b> 1387185			<b>Reason for Modification:</b> ADDENDUM NO_1 Bid Opening moves to 05/30/2024 @ 1:30pm
<b>Doc Description:</b> ADA Compliant Lowered Floor Minivans			
<b>Proc Type:</b> Central Master Agreement			
<b>Date Issued</b>	<b>Solicitation Closes</b>	<b>Solicitation No</b>	<b>Version</b>
2024-04-18	2024-05-07 13:30	CRFQ 0810 DMT2400000006	2

**BID RECEIVING LOCATION**

BID CLERK  
 DEPARTMENT OF ADMINISTRATION  
 PURCHASING DIVISION  
 2019 WASHINGTON ST E  
 CHARLESTON WV 25305  
 US

**VENDOR**

**Vendor Customer Code:**

**Vendor Name :** Transportation Equipment Sales Corp.

**Address :** 6401 Seaman Rd

**Street :**

**City :** Oregon

**State :** OH **Country :** USA **Zip :** 43616

**Principal Contact :** Jeff Pappas

**Vendor Contact Phone:** 419-836-2835 **Extension:**

**FOR INFORMATION CONTACT THE BUYER**  
 John W Estep  
 304-558-2566  
 john.w.estep@wv.gov

**Vendor Signature X**  **FEIN#** 34-1029900 **DATE** 5/21/2024

All offers subject to all terms and conditions contained in this solicitation

**ADDITIONAL INFORMATION**

ADDENDUM NO\_1

Addendum No\_1 issued to publish and distribute the attached information to the Vendor Community

REQUEST FOR QUOTATION:

The West Virginia Purchasing Division is soliciting bids on behalf of the Division of Multimodal Transportation Facilities -Public Transit (DMTF-PT); and any other agency that desires to utilize this contract, to establish an open-ended contract for Americans with Disabilities Act (ADA) Compliant Lowered Floor Min-Van(s). The offered vehicles would include wheelchair securements and a deployable ramp to provide transportation services in an urban/rural environment which includes mountainous terrain and a severe weather operating climate. The offered vehicle shall be capable to perform stop-start duty cycles. Per the Bid Requirements, Specifications, Terms and Conditions attached to this solicitation.

INVOICE TO		SHIP TO	
PUBLIC TRANSIT DIVISION OF BLDG 5 RM 663		PUBLIC TRANSIT DIVISION OF KANAWHA VALLEY REGIONAL TRANSPORTATION AUTHORITY	
1900 KANAWHA BLVD E CHARLESTON WV US		1550 FOURTH AVE CHARLESTON WV US	

Line	Comm Ln Desc	Qty	Unit Issue	Unit Price	Total Price
1	ADA Lowered Floor Minivans	10.00000	EA		

Comm Code	Manufacturer	Specification	Model #
25101502			

**Extended Description:**  
To establish an open-ended contract for ADA Lowered Floor Minivans. These vehicles will not possess any graphics.

**SCHEDULE OF EVENTS**

Line	Event	Event Date
1	Tech Questions dur by 10:00am	2024-04-26

# SOLICITATION NUMBER: CRFQ DMT2400000006

## Addendum Number: 1

The purpose of this addendum is to modify the solicitation identified as CRFQ DMT2400000006 ("Solicitation") to reflect the change(s) identified and described below.

### Applicable Addendum Category:

- Modify bid opening date and time
- Modify specifications of product or service being sought
- Attachment of vendor questions and responses
- Attachment of pre-bid sign-in sheet
- Correction of error
- Other

### Additional Documentation:

Bid Opening Moves to 05/30/2024 at 1:30pm

### Terms and Conditions:

1. All provisions of the Solicitation and other addenda not modified herein shall remain in full force and effect.
2. Vendor should acknowledge receipt of all addenda issued for this Solicitation by completing an Addendum Acknowledgment, a copy of which is included herewith. Failure to acknowledge addenda may result in bid disqualification. The addendum acknowledgement should be submitted with the bid to expedite document processing.

**ADDENDUM ACKNOWLEDGEMENT FORM**  
**SOLICITATION NO.: CRFQ DMT240000006**

**Instructions:** Please acknowledge receipt of all addenda issued with this solicitation by completing this addendum acknowledgment form. Check the box next to each addendum received and sign below. Failure to acknowledge addenda may result in bid disqualification.

**Acknowledgment:** I hereby acknowledge receipt of the following addenda and have made the necessary revisions to my proposal, plans and/or specification, etc.

**Addendum Numbers Received:**

(Check the box next to each addendum received)

- |  |  |
|--|--|
| <input checked="" type="checkbox"/> Addendum No. 1 | <input type="checkbox"/> Addendum No. 6  |
| <input type="checkbox"/> Addendum No. 2            | <input type="checkbox"/> Addendum No. 7  |
| <input type="checkbox"/> Addendum No. 3            | <input type="checkbox"/> Addendum No. 8  |
| <input type="checkbox"/> Addendum No. 4            | <input type="checkbox"/> Addendum No. 9  |
| <input type="checkbox"/> Addendum No. 5            | <input type="checkbox"/> Addendum No. 10 |

I understand that failure to confirm the receipt of addenda may be cause for rejection of this bid. I further understand that that any verbal representation made or assumed to be made during any oral discussion held between Vendor's representatives and any state personnel is not binding. Only the information issued in writing and added to the specifications by an official addendum is binding.

Transportation Equipment Sales Corporation

Company



Authorized Signature

5/29/2024

Date

**NOTE:** This addendum acknowledgment should be submitted with the bid to expedite document processing.



WVDOT

ADDENDUM NO\_2 CRFQ DMT2400000006

---



Department of Administration  
 Purchasing Division  
 2019 Washington Street East  
 Post Office Box 50130  
 Charleston, WV 25305-0130

State of West Virginia  
 Centralized Request for Quote  
 Vehicles

<b>Proc Folder:</b> 1387185		<b>Reason for Modification:</b>	
<b>Doc Description:</b> ADA Compliant Lowered Floor Minivans		ADDENDUM NO_2 Attach Modified Specifications and New Exhibit A Pricing Page	
<b>Proc Type:</b> Central Master Agreement			
<b>Date Issued</b>	<b>Solicitation Closes</b>	<b>Solicitation No</b>	<b>Version</b>
2024-04-29	2024-05-30 13:30	CRFQ 0810 DMT2400000006	3

<b>BID RECEIVING LOCATION</b>
BID CLERK DEPARTMENT OF ADMINISTRATION PURCHASING DIVISION 2019 WASHINGTON ST E CHARLESTON WV 25305 US

<b>VENDOR</b>		
<b>Vendor Customer Code:</b>		
<b>Vendor Name :</b> Transportation Equipment Sales Corp.		
<b>Address :</b> 6401 Seaman Rd		
<b>Street :</b>		
<b>City :</b> Oregon		
<b>State :</b> OH	<b>Country :</b> USA	<b>Zip :</b> 43616
<b>Principal Contact :</b> Jeff Pappas		
<b>Vendor Contact Phone:</b> 419-836-2835	<b>Extension:</b>	

<b>FOR INFORMATION CONTACT THE BUYER</b>
John W Estep 304-558-2566 john.w.estep@wv.gov

<b>Vendor Signature X</b> 	<b>FEIN#</b> 34-1029900	<b>DATE</b> 5/21/2024
---	-------------------------	-----------------------

All offers subject to all terms and conditions contained in this solicitation

<b>ADDITIONAL INFORMATION</b>
-------------------------------

ADDENDUM NO\_2

Addendum No\_2 issued to publish and distribute the attached information to the Vendor Community

REQUEST FOR QUOTATION:

The West Virginia Purchasing Division is soliciting bids on behalf of the Division of Multimodal Transportation Facilities -Public Transit (DMTF-PT); and any other agency that desires to utilize this contract, to establish an open-ended contract for Americans with Disabilities Act (ADA) Compliant Lowered Floor Min-Van(s). The offered vehicles would include wheelchair securements and a deployable ramp to provide transportation services in an urban/rural environment which includes mountainous terrain and a severe weather operating climate. The offered vehicle shall be capable to perform stop-start duty cycles. Per the Bid Requirements, Specifications, Terms and Conditions attached to this solicitation.

INVOICE TO	SHIP TO
PUBLIC TRANSIT DIVISION OF BLDG 5 RM 663  1900 KANAWHA BLVD E CHARLESTON WV US	PUBLIC TRANSIT DIVISION OF KANAWHA VALLEY REGIONAL TRANSPORTATION AUTHORITY 1550 FOURTH AVE CHARLESTON WV US

Line	Comm Ln Desc	Qty	Unit Issue	Unit Price	Total Price
1	ADA Lowered Floor Minivans	10.00000	EA		

Comm Code	Manufacturer	Specification	Model #
25101502			

**Extended Description:**  
 To establish an open-ended contract for ADA Lowered Floor Minivans. These vehicles will not possess any graphics.

<b>SCHEDULE OF EVENTS</b>
---------------------------

Line	Event	Event Date
1	Tech Questions dur by 10:00am	2024-04-26

# SOLICITATION NUMBER: CRFQ DMT2400000006

## Addendum Number: 2

The purpose of this addendum is to modify the solicitation identified as CRFQ DMT2400000006 ("Solicitation") to reflect the change(s) identified and described below.

### Applicable Addendum Category:

- Modify bid opening date and time
- Modify specifications of product or service being sought
- Attachment of vendor questions and responses
- Attachment of pre-bid sign-in sheet
- Correction of error
- Other

### Additional Documentation:

Attach Modified Specifications and New Exhibit A Pricing Page

Bid Opening remains 05/30/2024 at 1:30pm

### Terms and Conditions:

1. All provisions of the Solicitation and other addenda not modified herein shall remain in full force and effect.
2. Vendor should acknowledge receipt of all addenda issued for this Solicitation by completing an Addendum Acknowledgment, a copy of which is included herewith. Failure to acknowledge addenda may result in bid disqualification. The addendum acknowledgement should be submitted with the bid to expedite document processing.

**REQUEST FOR QUOTATION  
ADA LOWERED FLOOR MINIVANS  
EXHIBIT A PRICING PAGE**

Class	Vehicle Description	Unit Price Per Vehicle	Estimated Quantity	Extended Price
A	Vehicle, One wheelchair Position, White, No Stripes or Logos, Stowaway Ramp Under Floor	\$0.00	10	\$0.00
B	Vehicle, One Wheelchair Position, White, No Stripes or Logos, Foldaway Ramp	\$0.00	1	\$0.00

<b>TOTAL BID EVALUATION</b>	<b>\$0.00</b>
-----------------------------	---------------

Complete form provided  
Please note these are only estimated quantities and do not reflect any guarantee of purchase  
The DMT may purchase more or less as needed.  
Please do not alter Pricing Page

REQUEST FOR QUOTATION  
ADA Compliant Lowered Floor Minivans

---

SPECIFICATIONS

1. **PURPOSE AND SCOPE:** The West Virginia Purchasing Division is soliciting bids on behalf of the Division of Multimodal Transportation Facilities -Public Transit (DMTF-PT); and any other agency that desires to utilize this contract, to establish an open-ended contract for American's with Disabilities Act (ADA) Compliant Lowered Floor Minivan(s). The offered vehicles would include wheelchair securements and a deployable ramp to provide transportation services in an urban/rural environment which includes mountainous terrain and a severe weather operating climate. The offered vehicle shall be capable to perform stop-start duty cycles.

Vehicles supplied shall conform in all respects to the applicable Motor Vehicle Laws of the State of West Virginia, Federal Motor Vehicle Safety Standards, Environmental Protection Agency, Federal and State Regulations in effect at the time of manufacture and all must be in compliance with ADA regulations at the time production of the vehicle commences.

The Vendor is to deliver a new (current year) vehicle in one of proposed floor plans as defined in these specifications with different configurations identified as Class on the Exhibit A Pricing Pages, ready for operation. All required Federal Transit Administration's certification forms must be included in the bid proposal.

2. **DEFINITIONS:** The terms listed below shall have the meanings assigned to them below. Additional definitions can be found in section 2 of the General Terms and Conditions.
- 2.1 "ADA" means Americans with Disabilities Act of 1990 including applicable federal regulations issued pursuant to the Act in effect at the time production of the vehicle commences.
- 2.2 "ASTM" means American Society for Testing and Materials.
- 2.3 "Contract Item" or "Contract Items" means the list of items identified in Section 3.1 below and on the Pricing Pages.
- 2.4 "Curb Weight" means weight of the vehicle including maximum fuel, oil, and coolant and all equipment required for the operation as required by this specification without passengers or driver.
- 2.5 "DBA" means the decibel scale A weight to measure upper middle frequencies over time that can impact hearing loss.
- 2.6 "Division" means the West Virginia Division of Multimodal Transportation Facilities - Public Transit.
- 2.7 "DMV" means Division of Motor Vehicles State of West Virginia.

REQUEST FOR QUOTATION  
ADA Compliant Lowered Floor Minivans

---

- 2.8 “EPA” means Environmental Protection Agency.
- 2.9 “Fire Resistant” means Materials that have a flame-spread index less than 150 as measured in a radiant panel flame test per ASTM 162-75.
- 2.10 “Fireproof” means materials that will not burn or melt at temperatures less than 2,000 degrees Fahrenheit.
- 2.11 “FMVSS” means Federal Motor Vehicle Safety Standards.
- 2.12 “FTA” means Federal Transit Administration.
- 2.13 “GAWR FR” is the maximum distributed weight that may be supported by the front axle.
- 2.14 “GAWR RR” is the maximum distributed weight that may be supported by the rear axle.
- 2.15 “Gross Load” means one hundred and seventy-five (175) pounds for every design passenger seating position and for the driver and three hundred (300) pounds for every wheelchair station. Vehicles will be operated without standees.
- 2.16 “Gross Vehicle Weight Rating (GVWR)” means the maximum loaded weight (including curb weight, operator & passenger weight, and payload) in pounds (lbs.) of a single vehicle. Vehicle manufacturers specify the maximum GVWR on the vehicle certification label.
- 2.17 “HP” means the power of an engine measured in terms of a unit of power equal to 550-foot pounds per second.
- 2.18 “Manufacturer/Brand” means the name of the maker of the contract item which will be supplied by the vendor.
- 2.19 “Model & Number” means the model’s name and model number associated with the contract item as defined by the manufacturer.
- 2.20 “OEM” means Original Equipment Manufacturer.
- 2.21 “Powertrain” means the group of components used to transmit engine power to the wheels. The powertrain includes the engine, clutch, transmission, universal joints, drive shaft, and rear-axle gears.
- 2.22 “Pricing Page” means the pages, contained in wvOASIS, or attached as Exhibit A, upon which Vendor should list its proposed price for the Contract Items.
- 2.23 “QVM” means Qualified Vehicle Manufacturer.
- 2.24 “RPM” means Revolutions per minute.

REQUEST FOR QUOTATION  
ADA Compliant Lowered Floor Minivans

---

- 2.25 “SAE” means Society of Automotive Engineers.
- 2.26 “Solicitation” means the official notice of an opportunity to supply the State with goods or services that is published by the Purchasing Division.
- 2.27 “Vendor Name” means the company name of the vendor who will be supplying the contract item(s) to the Division.
- 2.28 “Warranty” means the written guarantee issued with new motor vehicles or related equipment. It defines the manufacturer’s responsibility for the repair or replacement of defective parts and other services provided as part of the purchase price. A warranty can be nullified if the user does not follow certain stipulations of the manufacturer, such as preventive maintenance.
- 2.29 “Wheelbase” means the distance from the centerline of the front axle to the centerline of the rear axle. Minimum of 121”.
- 2.30 “NTSA” means National Highway Traffic Safety Administration.
- 2.31 “DOT” means Department of Transportation.
- 2.32 “LED” means Light-Emitting Diode.

**3. GENERAL REQUIREMENTS:**

- 3.1 **Contract Items and Mandatory Requirements:** Vendor shall provide Division with the Contract Items listed below on an open-end and continuing basis. Contract Items shall meet or exceed the mandatory requirements as shown below.
  - 3.1.1 In all cases, materials shall be furnished as specified Where brand names or specific items or processes are used in the specification, consider the term or equal to follow.
    - 3.1.1.1 **Legal Requirements.** The vehicle shall meet all applicable FMVSS, DMV and ADA, federal and state regulations in effect at the date of manufacture. Vendor shall supply certification that vehicle meets all FMVSS Regulations, and that vehicle complies with all relevant federal and State of West Virginia Standards at the time of delivery.
    - 3.1.1.2 **Components, Materials, Workmanship and Completeness.** These specifications reflect the Division’s preference as to dimensions, materials, and major components. However, the vendor shall not omit any part of detail which goes to make the vehicle complete and

REQUEST FOR QUOTATION  
ADA Compliant Lowered Floor Minivans

---

ready for service, even though such part or detail is not mentioned in these specifications.

- 3.1.1.3 All units or parts shall be manufacturer's best quality and shall conform in material, design and workmanship to the best practice known in the automotive industry. All parts shall be new and in no case will used, reconditioned, or obsolete parts be accepted. The parts on all vehicles provided by the same manufacturer shall be interchangeable.
- 3.1.1.4 The price quoted in any proposal submitted shall include all items of labor, material, tools, equipment, and other costs necessary to fully complete the manufacture and delivery of the vehicle pursuant to these specifications.
- 3.1.1.5 It is the intent of these specifications to provide and require a complete vehicle of the type prescribed ready for operation. The vendor shall assume sole responsibility for the entire vehicle as to warranty and after-sale parts and service.
- 3.1.1.6 Warranty to become effective on the first day, after the date of final acceptance, of each vehicle by the Division.
- 3.1.1.7 **Exhaust Emission Control Requirements.** The vehicle shall comply with all federal and state requirements applicable to the year of manufacture.

**Regulations for Emission from Vehicles and Engines**

- 3.1.1.8 **Noise Control.** The exterior noise from the vehicle shall not exceed eighty-six (86) dba using the procedures set forth in the SAE Standard SAE J366. Vendor shall supply report showing testing results of noise control. The interior noise at a location (2) feet from the rear window and four (4) feet from the floor shall not exceed eighty-six (86) dba with the vehicle standing with the transmission in neutral and the engine operating at a maximum rated RPM.
- 3.1.1.9 Body shall be thoroughly water tested and made tight to prevent leakage. All vehicles purchased under this contract shall, during the course of the manufacture and prior to acceptance, shall be subjected to a water test to

REQUEST FOR QUOTATION  
ADA Compliant Lowered Floor Minivans

---

determine body leaks. This test shall consist of a series of nozzles, which are strategically located around the perimeter of the vehicle as to spray water over the entire surface of the vehicle. The nozzles shall eject a volume of water no less than twenty-two (22) pounds per square inch measured at the nozzle tip. Body shall be thoroughly water tested and made tight to prevent leakage. The bidder shall provide the procuring agency with details of its water testing procedures with the bid.

THE PRICING AND TERMS AND CONDITIONS OF THE BID MAY BE EXTENDED TO WEST VIRGINIA TRANSIT AUTHORITIES AND PRIVATE NON-PROFIT ORGANIZATIONS. IF VENDOR DOES NOT AGREE, VENDOR MUST CLEARLY INDICATE A REFUSAL IN HIS/HER BID.

**3.2 CHASSIS**

- 3.2.1** Chassis shall be current Model year Chrysler Voyager or equivalent meeting the following specifications and accepted industry standards.

**3.3 ENGINE / EXHAUST SYSTEM**

- 3.3.1** The vehicle shall be equipped with a gasoline engine with a displacement of at least 3.0 liters and no more than 4.0 liters providing between 280 – 300 horsepower with the operating fuel expenditure being between 15-21 City and 24-30 Highway miles per gallon.

Vendor shall submit product description, warranty information, and product literature with bid.

The engine shall be installed to produce a minimum of vibration. A firewall of sandwich construction shall separate the engine and passenger compartments, providing both thermal and acoustic insulation and sealing against intrusion of exhaust fumes into the vehicle. Non-combustible insulation shall be used.

- 3.3.2** The Exhaust System shall be stainless steel type and conform with all Federal and State requirements applicable to the year of manufacture.

Regulations for Emissions from Vehicles and Engines

REQUEST FOR QUOTATION  
ADA Compliant Lowered Floor Minivans

---

**3.4 COOLING SYSTEM**

- 3.4.1 Radiator and Cooling System shall be OEM standard, with coolant recovery system utilizing 50-50 mixture of factory specified antifreeze and water.

**3.5. FUEL SYSTEM**

- 3.5.1 Fuel tank shall be OEM holding between 15 and 25 gallons of gasoline and comply with all accepted industry safety standards.

FMVSS 301

California Air Resource Board (CARB)

**3.6 TRANSMISSION**

- 3.6.1 Transmission shall be fully automatic with an electronic six to nine speed range.
- 3.6.2 Transmission shift lever shall be interlocked with starting motor to prevent engagement of starter in any gear possible other than neutral or park.
- 3.6.4 A back up camera system will be installed on each vehicle so that the area around the back of the bus is clearly displayed on a monitor that is mounted in an easily visible area for the driver.

**3.7 SUSPENSION**

- 3.7.1 Suspension system components shall be matched and tuned to provide maximum load capacity, ride quality, stability, and desirable steering and handling characteristics. The vehicle shall be tested to FMVSS 126 Electronic Stability Control Test.

FMVSS 126 Electronic Stability Control Systems

REQUEST FOR QUOTATION  
ADA Compliant Lowered Floor Minivans

---

- 3.7.3 Vendor must perform a front–end alignment after each vehicle is completely built. Vendor shall supply a statement of completion verifying that alignment was completed with warranty information.

**3.8 STEERING**

- 3.8.1 Power steering is required, and the power steering mechanism shall be constructed so that the vehicle can be easily steered by its operator and shall be such as to make the wheel free from road shock and vibration. The steering mechanism shall be self-centering, requiring little or no effort from the operator to bring the vehicle back to straight ahead position after turning.
- 3.8.2 With the vehicle stationary at GVW on dry, level pavement and the engine idling, steering effort shall be as low as possible at the steering wheel. This effort shall remain approximately constant from just off straight ahead to approaching full lock.
- 3.8.3 The steering geometry shall allow the turning radius maximum characteristics to be achieved in both directions.
- 3.8.5 A tilt-wheel or adjustable steering column, with cruise control is required.

**3.9 BRAKES**

- 3.9.1 The vehicle shall be equipped with 4-wheel disc brakes and a factory Anti-Lock Brake System, as well as a factory OEM parking brake assemblies and dash warning light.
- 3.9.2 Brakes shall be capable of holding a fully loaded bus on a 20 percent grade.

**3.10 WHEELS**

- 3.10.1 The vehicle shall be equipped with four OEM wheels appropriate for the vehicle's intended use.

**3.11 TIRES**

- 3.11.1 The tires shall be OEM standard as specified by the chassis size for intended use.

REQUEST FOR QUOTATION  
ADA Compliant Lowered Floor Minivans

---

**3.12 ELECTRICAL SYSTEM**

- 3.12.1 Each vehicle shall have an OEM electrical charging system
- 3.12.2 Where penetration of structural members occurs, grommets or similar devices shall be used to prevent chafing.
- 3.12.3 Schematic for all added electrical equipment that shows where added equipment was electrically attached to existing factory electric power.
- 3.12.4 Alternator: Alternator shall be factory installed heavy duty. Must be high output with a minimum of 180 amp.

**3.13 INSTRUMENTS AND CONTROLS**

- 3.13.1 The following instruments shall be provided:
  - 3.13.1.1 AM/FM digital Bluetooth /radio with clock, MP3, USB
  - 3.13.1.2 Speedometer with recording odometer
  - 3.13.1.3 Ammeter or voltammeter gauge
  - 3.13.1.4 Low-charge warning light
  - 3.13.1.5 Oil pressure gauge
  - 3.13.1.6 Fuel tank level gauge(s)
  - 3.13.1.7 Engine temperature gauge
  - 3.13.1.7 Headlight on indication and headlight high beam indicator
  - 3.13.1.8 Directional signal and flasher action light
  - 3.13.1.9 Parking Brake Indicator
  - 3.13.1.10 Power Port for Cell Phone

REQUEST FOR QUOTATION  
ADA Compliant Lowered Floor Minivans

---

**3.14 BODY STRUCTURE**

- 3.14.1** Conversion of a minivan by modifying the existing, sidewalls, and floor, shall require the construction that maintains OEM structural equivalent. All metal welded components shall be constructed by qualified operators and made corrosion resistant through a commercial primer application or through the use of stainless steel or aluminum material.
- 3.14.2** Interior Height: Conversion shall provide a minimum clearance of 60" at the vehicle center of the interior roof.
- 3.14.3** Paint: The basic vehicle factory color shall be OEM standard white.
- 3.14.4** All nuts, bolts, clips, washers, clamps, and like-parts shall be galvanized, zinc-coated, or given a coat of primer as additional protection against corrosion. All exterior screws and bolts shall be stainless steel.
- 3.14.5** Interior surfaces of any exterior painted body panels and posts which are covered by trim materials shall be given a coat of primer as additional protections against deteriorations.
- 3.14.6** All exposed surfaces and edges shall be smooth, free from burs and other projections, and shall be neatly finished.
- 3.14.7** The Minivan shall have standard OEM driver and passenger front doors. One manual left side and one manual right OEM side doors extended to floor level, and one OEM rear hatch. The manual left and right-side sliding doors shall be OEM (to the extend the sliding mobility and accessible entry door accommodates the accessible entry ramp) and extended to floor level to provide a minimum entry height of 56". The passenger side sliding mobility aid accessible entry door shall be interlocked to the vehicle transmission and offer a minimum opening height of 56", minimum opening width of 31" (excluding grab handle), and a maximum of 12.5" floor-to-ground height. Both sliding doors shall have a mechanism to securely hold doors in open position when vehicle is on a hill or incline.
- 3.14.8** Passenger Door Tracks: Door tracks shall be reinforced or strengthened beyond OEM standards as appropriate in all areas of contact with sliding door arms.

REQUEST FOR QUOTATION  
ADA Compliant Lowered Floor Minivans

---

- 3.14.9 Sliding Passenger Door Arms/Brackets:** Reinforcement of the sliding door components shall at a minimum be adequate to support the increased weight created by the door extensions. Under normal closure conditions, there should be no evidence of door track flexing or wobbling.
- 3.14.10 Door Locks:** Power with child-protection door locks for rear doors.
- 3.14.11 Rear Door Emergency Exit:** the rear cargo door shall be provided with a quick release, manual override for opening the door from inside the vehicle. Capable of opening the door even if the door is locked. The vehicles override device shall be spring loaded and mounted on the inside of the rear door to prevent accidental release. A decal shall be provided showing operating instructions.
- 3.14.12 Wheel housing** shall be steel and should provide clearance for wheels equipped with chains to move freely and to allow a wheel to be removed with the vehicle jacked up as factory recommended – front or back. Rear fenders should be flexible.
- 3.14.13** The entire surface of exterior lowered floor shall have a rust inhibiting coating, such as an epoxy primer base, applied to cover all welded areas, and then a fresh application of undercoating over the entire surface. The warranty shall be 5 years on the undercoat and rustproofing. It is required that the vendor supply the description, warranty and literature information of this product with the bid.
- 3.14.14** The basic interior color shall be OEM gray, with gray (upper) and black (lower) ABS form fitted plastic panels. Panels fastening devices shall match the color of the panels. Interior panels shall meet FMVSS 302. The interior shall provide a pleasant atmosphere, be aesthetically pleasing, and contain smooth finishes without any unprotected sharp edges.
- FMVSS 302
- 3.14.15** A firewall shall separate the engine and passenger compartments, providing both thermal and acoustic insulation, sealing against intrusion of exhaust gases into the vehicle and providing sufficient sound attenuation to maintain a maximum of 86db level in the passenger compartment. The firewall shall be constructed of flame resistant material.

REQUEST FOR QUOTATION  
ADA Compliant Lowered Floor Minivans

---

**3.14.16 Roof Gutters**

Water deflecting roof gutters shall be provided over ambulatory and Wheelchair accessible doors, over the passenger windows, and over the driver's windshield where necessary.

**3.14.17 Exterior**

Paint – Surface shall be properly cleaned and primed, as appropriate, for the paint used. All exterior surfaces shall be impervious to gasoline and commercial cleaning agents. The exterior of each van shall be painted a basic white color as furnished by the chassis manufacturer. Fiberglass matching the color of the chassis is acceptable. Finished surfaces shall not be damaged by controlled application of commonly used graffiti- removing chemicals. Touch up paint for each paint color used shall be provided.

**3.14.19 Paint Scheme**

The vehicle will be delivered without graphics, in a standard white color scheme.

**3.15 WINDOWS**

**3.15.1** Glass shall be OEM laminated, tinted safety glass, with all latch mechanisms recessed

**3.15.2** Windshield shall be fixed type, with safety laminated glass, tinted above eye level.

**3.16 HEATING AND VENTILATION**

**3.16.1** An OEM heating/defrosting and air conditioning system with vents front and rear shall be provided. All lines and hoses shall be sufficiently fastened protected, and insulated to ensure against wear from friction and the elements. The lines must be mechanically attached, with OEM or equivalent clamps, to the vehicle structure and must be routed so as not to be exposed to wheel spray. Cold feed lines shall not pass within 2 inches of any part of the exhaust system. Conversion shall not impede access to front and rear air conditioning components.

REQUEST FOR QUOTATION  
ADA Compliant Lowered Floor Minivans

---

**3.17 INTERIOR LIGHTING**

- 3.17.1** LED lower lighting may be added at the center row location of the vehicle that provides not less than two foot-candles of illumination at the entrance area. This system shall illuminate automatically when the vehicle front or sliding doors are open. All accessory vehicle lighting shall conform to ADA 49 CFR, Part 38, Subpart B.  
ADA 49 CFR, Part 38, Subpart B: ADA 49 CFR, Part 38, Subpart B.

**3.18 EXTERIOR LIGHTING**

- 3.18.1** Exterior lighting shall be in accordance with Federal Motor Carrier Safety Regulations (393.11). All exterior lights to be single contact. Double contact may be used for tail, stop, and rear turn signals.  
  
Federal Motor Carrier Safety Regulation 393.11
- 3.18.2** OEM headlights or LED headlights sealed from moisture intrusion with high and low beams controlled by a column-mounted lever switch or by a foot switch mounted on the floor, which will be sealed from moisture, are required. Headlamps units shall be of the latest type and low beam rating of 600-hour life minimum. Headlights shall be wired for daytime running. Headlights and headlight support and mountings shall be sufficiently rugged to maintain adjustments under road shock and service conditions. Headlight high beam indicator shall be installed on instrument panel. An audible "headlight on" warning buzzer shall be installed to notify the operator that the lights are on with the engine turned off.
- 3.18.3** Tail lamps shall be mounted on the rear of the vehicle so as not to be affected by engine exhaust heat. Each side shall include a hazard, signal, tail, and stop light. Lamp lenses shall not protrude from body more than two inches (2"). Lights shall consist of sealed, single unit light fixtures.
- 3.18.4** Rear tail lamps shall include a pair of amber combinational hazard and signal lights. Rear tail lamps shall also include a pair of red taillights and red stoplights, which may be combinational.

REQUEST FOR QUOTATION  
ADA Compliant Lowered Floor Minivans

---

- 3.18.5 Brake lights shall not override emergency flashers or turn signals. A collision avoidance light shall be installed on the rear at the centerline of the vehicle. It shall be activated simultaneously with the stop lamp circuit.
- 3.18.6 Two (2) back-up lights adequate to illuminate for visibility when backing shall be furnished. One mounted on each side of the vehicle. The lamps shall each be a sealed, single unit light fixture.
- 3.18.7 Passenger entry door area shall adequately illuminate with either an exterior light or interior mounted light to illuminate the area immediately around the passenger side slide door.
- 3.18.8 Each vehicle shall be equipped with an exterior curb lamp. Light shall be positioned in manufacturer's standard location in such a manner as to illuminate the ground area in the immediate vicinity of the area of operation of the wheelchair lift. Light shall be automatically activated only when the wheelchair lift doors are open. Illumination shall be sufficient to comply with ADA requirements.

**3.19 INTERIOR DECALS**

- 1) **"No Smoking"** at the front top of vehicle.
- 2) **"All Passengers Are Required To Wear Seat Belts When Vehicle Is In Motion"** at the front top of the vehicle.
- 3) **"Clearance \_\_\_\_\_ feet \_\_\_\_\_ inches"**  
above driver's visor. (The specific figures on clearance will be determined by exact dimensions of vehicle.)
- 4) **Emergency Dial 911:**
- 5) **EMERGENCY EQUIPMENT** - Apply to the First Aid Kit.

**3.20 EXTERIOR DECALS:**

- 1) **"This Vehicle Makes Frequent Stops"** on the back of the vehicle.
- 2) The International Wheelchair Accessibility Symbol on the back of the vehicle.

REQUEST FOR QUOTATION  
ADA Compliant Lowered Floor Minivans

---

- 3) **"CAUTION: Loading and Unloading Passengers"** on the back of vehicle.

The exterior decals shall have 3" lettering shall be white letters on red black ground.

### 3.21 SEATING

All seats in the vehicle as specified must comply with current FMVSS standards.

#### FMVSS Standard 207 Seating System

- 3.22.1 Front Seats:** The driver seat will be OEM and mounted to the vehicle floor.

The OEM front passenger seat shall be equipped to easily lock/unlock from the floor and permit easy roll out for mobility aid access/securement.

- 3.22.2 Rear Seat:** The third row 3-passenger bench seat shall be the OEM seat, remounted to be capable of accommodating 3 adult passengers, and is to be covered with OEM upholstery to match the driver and front passenger seats. A manually operated one-piece lighted footrest will be installed for increased comfort of rear bench seat passengers.

- 3.22.3 Passenger Restraint:** Restraints shall be furnished for all passengers, consisting of shoulder seatbelts and/or lap belts. Each belt shall be equipped with an automatic retractor. Securement devices, both for ambulatory and mobility aid passengers, shall meet all State and Federal Standards.

49 CFR Standard No. 210

- 3.22.4 Grab Handles:** Grab handle shall be installed, OEM are acceptable.

### 3.22 ALTOONA BUS TESTING REPORT

The converted minivan must have been submitted to the Altoona Bus Test Center for a 4 year/ 100,000-mile Surface Transportation and Uniform Relocation Assistance Act (STURAA) test. Testing must have been completed on current body style being converted. A copy of the test report should be submitted with the Vendor's submitted bid

REQUEST FOR QUOTATION  
ADA Compliant Lowered Floor Minivans

---

response. This information may be required before award of contract.

FTA Bus Testing Standard

**3.23 EMERGENCY/SAFETY EQUIPMENT**

- 3.24.1** First Aid Kit - First-Aid Kit shall comply with Federal Motor Vehicle Carrier Safety Regulations Part 393(h), Section 393, Part 96(c), with a minimum of 15 units. First-aid kits shall be stored in storage compartment or mounted so as to provide for easy access in the event of an accident, away from foot traffic.

Federal Motor Carrier Safety Administration Emergency Equipment

- 3.24.2** Kit shall be housed in a metal box which contains at least the following items:

- 3.24.2.1** Instant Cold Pack (1)
- 3.24.2.2** Certicaine Burn Spray (1 oz.)
- 3.24.2.3** 1" x 3" Adhesive Bandages (25)
- 3.24.2.4** 3/4" x 3" Adhesive Bandages (10)
- 3.24.2.5** Extra Large Adhesive Bandages (10) 3" x 3"
- 3.24.2.6** Gauze Pads (10)
- 3.24.2.7** Antiseptic Wipes (10)
- 3.24.2.8** Alcohol Prep Pads (20)
- 3.24.2.9** Ammonia Inhalants (10)
- 3.24.2.10** 2" x 6 yds. Gauze Bandage
- 3.24.2.11** 1/2" x 2.5 yds. Adhesive Tape
- 3.24.2.12** Burn Ointment (1/8 oz.) (4)
- 3.24.2.13** Insect Sting Swabs (4)
- 3.24.2.14** PVP Iodine Swabs (4)
- 3.24.2.15** Tweezers (1)

REQUEST FOR QUOTATION  
ADA Compliant Lowered Floor Minivans

---

**3.24.2.16** Scissors (1)

**3.24.2.17** Safety Pins (5)

**3.24.3** Fire Extinguisher - A 5 lb. dry chemical fire extinguisher with a minimum of a 20-A: 180-B:C rating shall be provided in vehicle and shall be mounted in an access compartment with a hinged door or on a vehicular-type quick access bracket away from foot traffic.

**3.24.4** Reflectors - Three bi-directional emergency reflective triangles conforming to requirements of FMVSS No. 125, Section 571.125 shall be secured in the storage compartment of the vehicle.

FMVSS No. 125, Section 571.125

**3.24.5** Jumper Cables - Jumper cables of stranded copper, 4-6 gauge, seven (7) feet minimum length shall be secured in the storage compartment of the vehicle.

**3.24.6** Bloodborne Pathogen Protection Kit - A 10-unit (minimum) kit housed in a polypropylene or metal box and containing at least the following items:

**3.24.6.1** Gown/Cap (1)

**3.24.6.2** Goggles (Eye Shield) (1)

**3.26.6.3** Mask (1)

**3.26.6.4** Sets of Gloves (3)

**3.26.6.5** Scraper (1)

**3.26.6.6** Crepe Towels (2)

**3.26.6.7** Antiseptic Towelettes (4)

**3.26.6.8** Disinfectant Towelette (4)

**3.26.6.9** Mouth to Mouth Barrier (1)

**3.26.6.10** Scoop Bag (3)

**3.26.6.11** Infectious Liquid Control Powder (2 oz.)

**3.26.6.12** Red Bio-Hazard Bags with Ties (2)

REQUEST FOR QUOTATION  
ADA Compliant Lowered Floor Minivans

---

**3.24.7** Wheel Jack & Lug Wrench secured in a location approved by the Division of Public Transit.

**3.24.8** Seat Belt Cutter – shall be secured in the storage compartment of the vehicle.

**3.24 MIRRORS**

**3.25.1** Interior OEM Rearview Mirror.

**3.25.2** Exterior Two rearview, one right and one left power adjustable mirrors to be installed. If not OEM, it is required that the vendor supply the description, warranty and literature information of this product with the bid.

**3.25 FRONT AND REAR HEATING AND AIR CONDITING**

**3.26.1** An OEM heating/defrosting and air condition system with vents front and rear shall be provided. All lines and hoses shall be sufficiently fastened, protected, and insulated to ensure against wear from friction and the elements. The lines must be mechanically attached with OEM clamps, to the vehicle structure at no greater than 18-inch intervals and must be routed so as not to be exposed to wheel spray and not pass within 2 inches of any part of the exhaust system. Conversion shall not impede access to front and rear air condition components.

**3.26 WHEELCHAIR SECUREMENT SYSTEM**

**3.27.1** It is required that the vendor supply the description, warranty and literature information of this product with the bid.

**3.27.2** Wheelchair securement areas and systems shall fully comply with all applicable U.S. Department of Transportation's Americans with Disabilities Requirements. NHTSA requires a 3-point shoulder restraint system shall be supplied for each passenger for vehicles under 10,000 GVWR.

**3.27.3** Vehicle shall be equipped with one (1) wheelchair position. Each required wheelchair position a wheelchair securement system shall be provided to securely hold the wheelchair in the wheelchair position.

**3.27.4** Provisions shall be made, in the wheelchair position area, to stow the straps and buckles off the floor when they are not in use. The stored straps shall not interfere with passenger movement or sitting space. Vendor shall

REQUEST FOR QUOTATION  
ADA Compliant Lowered Floor Minivans

---

submit description and location of product with bid.

- 3.27.5** The vendor shall provide with each vehicle upon delivery a pamphlet, brochure or similar literature describing and instructing the use of the wheelchair securement system and shall demonstrate to the recipient the proper method of using the system. Demonstration of the securement system must be performed to insure correct use of the system.
- 3.27.6** A Freedman Seating 3 Step Forward Facing Fold Down Double Seat, or equal, shall be used in every wheelchair position for use by non-disabled persons when the securement system is not needed. When folded up, the seat shall not interfere with the use of the wheelchair positions by passengers in wheelchairs. An under-seat retractable seat belt shall be provided for each seated position.
- 3.27.7** The wheelchair station shall have a securement system fully complying with ADA requirements and capable of securing most common wheelchairs and other mobility aid devices. Each wheelchair space shall have at least 3-5" in between each space for easy access of driver.

**3.28 WHEELCHAIR OCCUPANT RESTRAINT SYSTEM**

- 3.28.1** A restraint system shall be provided for the occupant of the wheelchair at each wheelchair position. The restraint system shall be a seat belt assembly permanently attached to the floor or side of the vehicle or to the wheelchair lock supports. The restraint system shall be capable of securing a passenger in all types of wheelchairs or Scooters, while the chairs are locked in position. The seat belt shall be at least eighty (80) inches long and shall be easily fastened and unfastened by the wheelchair occupant. Each seat belt shall be equipped with a retractor or other device, which keeps the seat belt webbing or strap off the floor when the seat belt is not in use.
- 3.28.2** A complete retractable wheelchair and occupant restraint system with S-Hooks shall be installed at the wheelchair location. The system will have automatic belt retractors; tensioning knobs; and easy to use tension release mechanisms. The system shall be a Titan AL712S-4C; Q-Straint QRT Deluxe or approved equal. L-Track System to be used.
- 3.28.2.1** Wheelchair retractors shall be fully automatic, auto locking and self-tensioning.

REQUEST FOR QUOTATION  
ADA Compliant Lowered Floor Minivans

---

- 3.28.2.2** Retractors shall automatically remove any slack in the webbing after they are secured to the wheelchair.
- 3.28.2.3** Retractors are self-retracting; therefore, no belts are left on the floor, keeping them cleaner and longer lasting.
- 3.28.2.4** Retractor shall have a "LOCKED" indicator tag and shall only be visible when the retractor is in the LOCKED mode assuring the retractor is not in the release condition when properly secured to the wheelchair.
- 3.28.2.5** Retractors shall be heavy duty with heat treated structural components and plated for superior corrosion resistance.
- 3.28.2.6** Retractors shall have appropriately finished metal cover for long lasting protection.
- 3.28.2.7** Retractors shall have colored webbing and the occupant restraints shall be of a contrasting color for easy identification in the field.
- 3.28.2.8** Retractors shall be designed to be low profile to fit under most wheelchair footrests.
- 3.28.2.9** Retractors shall be equipped with anchoring points for the attachment of the occupant restraint lap belts.
- 3.28.2.10** Retractors shall be able to be used with a variety of shoulder/lap Belt combinations.
- 3.28.2.11** Retractors shall have manual knobs for additional tightening if needed.
- 3.28.2.12** Retractor shall be able to secure a wheelchair with one hand in as little as 10 seconds.
- 3.28.2.13** Retractors shall have a warranty period of at least the industry standard and shall have a manufacturing label to identify the part number and date of manufacture for easy traceability.
- 3.28.2.14** Retractors, occupant restraints and anchoring equipment shall be installed in accordance with the manufacturer's installation instructions and recommendations.
- 3.28.2.15** Retractors and occupant restraints shall meet or exceed but not limited to the following specifications:

REQUEST FOR QUOTATION  
ADA Compliant Lowered Floor Minivans

---

SAE J2249

ISO 10542

National Standard for School Buses Standard 222

ADA 49 CFR Part 38

FMVSS 209

FMVSS 302

Canadian Z605

It is required that the vendor supply the description, warranty and literature information of this product with the bid.

**3.29 WHEELCHAIR RAMP:**

**3.29.1** The vehicle shall be equipped with a manually operated access ramp which stows vertically or under the floor and is deployed through the right-side sliding door. The fold and unfold motion of the ramp must be counter balanced so that the operator can easily deploy the ramp. The installed ramp shall not obstruct the view of the driver through any vehicle window. The ramp shall have a minimum usable width of 30" and a slope meeting the requirements of ADA, 49 CFR. The ramp surface shall be continuous and made skid resistant. It shall accommodate both four-wheel and three-wheel mobility aids. The ramp shall have a rated capacity of 1000 lbs. and possess industry standard protective features.

ADA CFR 49

**3.30 AM/FM DIGITAL BLUETOOTH/ RADIO WITH CLOCK**

Vehicle shall be equipped with the OEM's AM/FM radio/USB/MP3 stereo with Bluetooth connectivity.

**3.31 MISCELLANEOUS ADDITIONS**

**3.31.1** Each vehicle shall be equipped with rear window defroster.

**3.31.2** Each vehicle shall have installed power windows and locks on all doors.

**3.31.3** Each vehicle shall be equipped with driver and passenger air bags.

REQUEST FOR QUOTATION  
ADA Compliant Lowered Floor Minivans

---

**3.31.4** Each vehicle shall be equipped with a sun visor for driver and front passenger that is able to pivot to cover their doors.

**3.31.5** Provide and install in each vehicle Angel Trax Vulcan Series V12 HD IP Mobile DVR Security Camera System with 6 cameras or equivalent having One TB SATA Hard drive with back up recording on SD Card and six audio/video channels or equivalent.

**3.32 MANUALS**

The vendor shall furnish each vehicle with complete driver, parts and maintenance manuals, including AS-BUILT wiring schematics of auxiliary circuits, air line diagrams and all other necessary prints for the maintenance of the wheelchair lift, auxiliary air conditioning unit and any other optional items added by the vendor during conversion.

**3.33 UNSPECIFIED ACCESSORIES & FEATURES**

All parts, equipment, accessories, material, design and performance characteristics not specified herein, but which are necessary to provide a complete unit, must be furnished with each unit and required to confirm to strength, quality of material, and quality of workmanship to those which are advertised and provided to the market in general by the unit industry. All parts and accessories advertised and regularly supplied as standard shall be included, except those which would represent duplication of these specified and except those which, by specification, are not to be furnished. All standard safety features, required by Federal and State Law, shall be included. Vehicles must have all equipment found on the manufacturer's base model plus other equipment requirements, packages, items, etc. needed to meet the specifications.

**4 REQUIREMENTS SPECIFIC TO EACH VEHICLE CLASS**

**4.1 Class A:** Vehicles identified as Class A vehicles must meet the following mandatory requirements in addition to the requirements listed in Section 3. Class A Vehicle will NOT have any Striping or Logo's, Painted White.

**4.1.1 Measurements and Other Specifications:**

GVWR	6,000 minimum
WHEELBASE	121" Minimum
SEAT/WHEELCHAIR CAPACITY	Five / One
PASSENGER HEAT & A/C	OEM Front & Rear System
ENGINE TYPE	Gasoline
ENGINE CAPACITY	Displacement of at least 3.0 liters and no more than 4.0 liters providing between 280 – 300

**Commented [DP1]:** 4.1 Same as above for Engine Capacity

REQUEST FOR QUOTATION  
ADA Compliant Lowered Floor Minivans

---

BRAKES	horsepower with the operating fuel expenditure being between 15-21 City and 24-30 Highway miles
BATTERY	4 Wheel Disc / Anti-Lock System
WHEELCHAIR RAMP	OEM Manual / Right Side

5 ADDITIONAL REQUIREMENTS APPLICABLE TO ALL VEHICLES

5.1 Summary of Items To Be Provided Upon Delivery

The following items shall be furnished by the successful Vendor upon delivery of the vehicle:

- a. All warranty verification vouchers, certificates or coupons.
- b. Supply two (2) sets of the following manuals, per model year, for each transit authority that receives vehicles:
  - Two (2) complete parts books
  - Two (2) maintenance manuals
  - Including wiring schematics of auxiliary circuits and all other necessary prints for the maintenance of the vehicle and
  - One (1) OEM operations manual

For other agencies receiving vehicles, the successful bidder shall supply one (1) copy of each mentioned per vehicle.
- c. Completely filled fuel tank or tanks.
- d. Protection to 20° F below zero with permanent type antifreeze.
- e. A vehicle(s) free of dealer signs and emblems.
- f. Assurance of compliance with manufacturer's pre-delivery service.
- g. A vehicle(s) which is clean, (If delivery of the vehicle occurs during the winter months of October through March, the vehicle shall be washed directly prior to delivery at designated recipient or Kanawha Valley Regional Transportation Authority to ensure that the vehicle is free of dirt and salt deposits) lubricated, serviced and ready for immediate service.
- h. Operation, maintenance and warranty information for any add on equipment will be provided upon delivery if available to the Vendor.

REQUEST FOR QUOTATION  
ADA Compliant Lowered Floor Minivans

---

- i. Original vehicle chassis manufacturer's factory sticker itemizing equipment on the vehicle.
- j. A certified weight slip showing front and drive axle weights for the vehicle at its curb weight as defined in Technical Specifications.
- k. Proof of Alignment.
- l. Vehicle shall comply with and conform to the State of West Virginia Motor Vehicle Inspection Law and shall have the current inspection sticker attached to the windshield.

**5.2 Title**

Adequate documents for securing the vehicle in the name of the Division shall be provided to the Division at least 10 working days prior to the delivery of each vehicle. The Vendor warrants that the title shall pass to the Division free and clear of all liens, mortgages and encumbrances, financing statements, security agreements, claims and demands of any character.

According to WV State Code §5A-3-4(8), vendor agrees that liquidated damages shall be imposed at the rate of \$10 per calendar day for failure to provide the titling documentation at the time of vehicle delivery. This clause shall in no way be considered exclusive and shall not limit the State or agency's right to pursue any other additional remedy to which the State or agency may have legal cause for action including further damages against the vendor.

All documentation (Certificate of Origin, Delivery/Odometer Statement, Etc.) in original form must be mailed or hand carried to:

WV Division of Multimodal Transportation Facilities -  
Public Transit  
1900 Kanawha Blvd., East  
Building 5, Room 663  
Charleston, WV 25305

REQUEST FOR QUOTATION  
ADA Compliant Lowered Floor Minivans

---

**5.3 QUALITY ASSURANCE**

**5.3.1 QUALITY ASSURANCE ORGANIZATION**

The Vendor shall establish and maintain an effective quality assurance organization. It shall be a specifically defined organization and should respond directly to the Vendor's management. The Vendor's complete quality assurance program for purchased components and in-plant inspection procedures shall be available for review by the Division prior to award.

**Control**

The quality assurance organization shall exercise quality control over all phases of production from initiation of design through manufacture and preparation for delivery. The organization shall also control the quality of supplied articles.

**Authority and Responsibility**

The quality assurance organization shall have the authority and responsibility for reliability, quality control, inspection planning, establishment of the quality control system, and acceptance/rejection of materials and manufactured articles in the production of the vehicles.

**5.3.2 QUALITY ASSURANCE ORGANIZATION FUNCTIONS**

The quality assurance organization shall include the following minimum functions.

**Work Instructions**

The quality assurance organization shall verify inspection operation instructions to ascertain that the manufactured product meets all prescribed requirements.

**Records Maintenance**

The quality assurance organization shall maintain and use records and data essential to the effective operation of its program. These records and data shall be available for review by the resident inspectors. Inspection and test records for this procurement shall be available for a minimum of one (1) year after inspections and test are completed.

**Corrective Actions**

The quality assurance organization shall detect and promptly assure correction of Any condition that may result in the production of defective vehicles. These conditions may occur in designs, purchases, manufacture, tests, or operations that

REQUEST FOR QUOTATION  
ADA Compliant Lowered Floor Minivans

---

culminate in defective supplies, facilities, technical data, or standards.

### **5.3.3 STANDARDS AND FACILITIES**

#### **Configuration Control**

The Vendor shall maintain drawings and other documentation that completely describe a quality vehicle that meets all of the options and special requirements of this procurement. The quality assurance organization shall verify that each vehicle is manufactured in accordance with these controlled drawings and documentation.

#### **Measuring and Testing Facilities**

The Vendor shall provide and maintain the necessary gauges and other measuring and testing devices for use by the quality assurance organization to verify that the vehicles conform to all specification requirements. These devices shall be calibrated at established periods against certified measurement standards that have known valid relationships to national standards.

#### **Production Tooling as Media of Inspection**

When production jigs, fixtures, tooling master patterns, and other devices are used as media of inspection, they shall be proved for accuracy at formally established intervals and adjusted, replaced, or repaired as required to maintain quality.

#### **Equipment Use By Division's Inspector(s)**

The Vendor's gauges and other measuring and testing devices shall be made available for use by the Division's inspector(s) to verify that the vehicles conform to all specification requirements. If necessary, the Vendor's personnel shall be made available to operate the devices and to verify their condition and accuracy.

### **5.3.4 CONTROL OF PURCHASES**

The Vendor shall maintain quality control of purchases.

#### **Supplier Control**

The Vendor shall require that each supplier maintains a quality control program for the services and supplies that it provides. The Vendor's quality assurance organization shall inspect and test materials provided by suppliers for conformance to specification requirements. Materials that have been inspected, tested, and approved shall be identified as acceptable to the point of use in the manufacturing or assembly processes. Controls shall be established to prevent inadvertent use of non-conforming materials.

REQUEST FOR QUOTATION  
ADA Compliant Lowered Floor Minivans

---

**Purchasing Data**

The Vendor shall verify that all applicable specification requirements are properly included or referenced in purchases of articles to be used on vehicles.

**5.3.5 MANUFACTURING CONTROL**

The Vendor shall ensure that all basic production operations, as well as all other processing and fabricating, are performed under controlled conditions, establishment of these controlled conditions shall be based on the documented work instructions, adequate production equipment, and special working environments if necessary.

**Completed Items**

A system for final inspection and test of completed vehicles shall be provided by the quality assurance organization. It shall measure the overall quality of each completed vehicle.

**Non-conforming Materials**

The quality assurance organization shall monitor the Vendor's system for controlling non-conforming materials. The system shall include procedures for identification, segregation, and disposition.

**Statistical Techniques**

Statistical analysis, tests, and other quality control procedures may be used when appropriate in the quality assurance processes.

**Inspection Status**

A system shall be maintained by the quality assurance organization for identifying the inspection status of components and completed vehicles. Identification may include cards, tags, or other normal quality control devices.

**5.3.6 INSPECTION SYSTEM**

The quality assurance organization shall establish, maintain, and periodically audit a fully documented inspection system. The system shall prescribe inspection and test of materials, work in progress and completed articles. At a minimum, it shall include the following controls.

REQUEST FOR QUOTATION  
ADA Compliant Lowered Floor Minivans

---

**Inspection Stations**

Inspection stations shall be at the best locations to provide for the work content and characteristics to be inspected. Stations shall provide the facilities and equipment to inspect structural integrity; electrical; hydraulic; through floor securements; OEM defects; coverage of the undercoating; and other components and assemblies for compliance with the design requirements.

Stations shall also be at the best locations to inspect or test characteristics before they are concealed by subsequent fabrication or assembly operations. These locations shall minimally include, as practicable, underbody structure completion, body framing completion, body prior to paint preparation, water test before interior trim and insulation installation, engine installation completion, underbody dress-up and completion, vehicle prior to final paint touch up, vehicle prior to road test, and vehicle final road test completion.

The manufacturer shall provide on its premises a suitable means for a complete inspection of the underside of the vehicle.

**Inspection Personnel**

Sufficiently trained inspectors shall be used to ensure that all materials, components, and assemblies are inspected for conformance with the qualified vehicle design.

**Inspection Records**

Acceptance, rework, or rejection identification shall be attached to inspected articles. Articles that have been accepted as a result of approved materials review actions shall be identified. Articles that have been reworked to specified drawing configurations shall not require special identification. Articles rejected as unsuitable or scrap shall be plainly marked and controlled to prevent installation on the vehicle. Articles that become obsolete as a result of engineering changes for other actions shall be controlled to prevent unauthorized assembly or installation. Unusable articles shall be isolated and then scrapped.

Discrepancies noted by the Vendor or Division's inspector during assembly shall be entered by the inspection personnel on a record that accompanies the major component, subassembly, or vehicle from start of assembly through final inspection. Actions shall be taken to correct discrepancies or deficiencies in the manufacturing processes, procedures, or other conditions that cause articles to be in nonconformity with the requirements of the contract specifications. The inspection personnel shall verify the corrective actions and mark the discrepancy record. If discrepancies cannot be corrected by replacing the non-conforming materials, the

REQUEST FOR QUOTATION  
ADA Compliant Lowered Floor Minivans

---

Division shall approve the modification, repair, or method of correction to the extent that the contract specifications are affected.

**Quality Assurance Audits**

The quality assurance organization shall establish and maintain a quality control audit program. Records of this program shall be subject to review by the Division.

**Division's Inspector(s)**

The Division may be represented at the Vendor's plant by their inspectors, they shall monitor, in the Vendor's plant, the manufacture of vehicles built under this procurement. The Division's inspectors shall be authorized to release the vehicles for delivery. Upon request to the quality assurance supervisor, inspectors shall have access to the Vendor's quality assurance files related to this procurement. These files shall include drawings, material standards, parts lists, inspection processing and reports, and records of defects. The presence of these inspectors in the plant shall not relieve the Vendor of its responsibility to meet all of the requirements of this procurement.

The Division's inspectors shall not have the authority to stop the Vendor's production line until any apparent problem area of major significance that arises to warrant such actions is fully discussed with the Vendor's top management.

**5.4 SERVICE AND PARTS**

The Vendor shall state on Bid Form #1 the representative(s) responsible for assisting the Recipient Agencies, as well as, the location of the nearest distribution center(s) which shall furnish a complete supply of parts and components for the repairs and maintenance of the vehicles to be supplied.

**5.5 Materials and Workmanship**

- a. Vendor shall incorporate in the proposed vehicle(s) the latest technological achievements consistent to achieving maximum service live and superior attractiveness of appearance.
- b. Vehicle(s) shall be delivered in new, first-class condition, complete and ready for operation on the street and the Vendor shall assume all responsibility and liability incident to said delivery.
- c. All materials used in the construction of vehicle(s) and in all its parts and accessories shall conform to A.S.T.M., S.A.E., or similar associations published standards, and be of top quality.

REQUEST FOR QUOTATION  
ADA Compliant Lowered Floor Minivans

---

- d. The vehicle(s) shall be built with suitable and easily accessible compartments provided for all apparatus, sound deadening insulation, wherever needed, and all operating devices so mounted as to reduce and keep all noise and vibration to an absolute minimum.
- e. Vendor shall assume responsibility for all material and accessories used in vehicle(s) and their proper installation and their warranty, whether the same is manufactured by the Vendor or purchased ready-made from a source outside the Vendor's company.

**5.6 Spare Parts** – The Vendor shall guarantee the availability of replacement parts for these vehicles for at least a seven (7) year period after the date of acceptance. Spare parts shall be interchangeable with the original equipment and shall be manufactured in accordance with the quality assurance provision of this contract.

**5.7 Engineers** – The Vendor shall, at its own expense, have a competent engineering representative(s) available on request to assist the Recipient Agencies staff in the solution of engineering or design problems within the scope of the specifications that may arise during the warranty period.

**5.8 Documents** – The Vendor shall keep maintenance manuals available for a period of ten (10) years after the date of acceptance of the vehicles procured under this contract. The Vendor shall also keep parts books up to date for a period of ten (10) years. The supplied maintenance and operators' manuals shall incorporate all equipment ordered on the vehicles covered by this procurement.

**5.9 WARRANTIES**

The Vendor has an obligation to ensure that the entire vehicle is covered by a warranty. The Vendor shall make every effort to assure that all obligations defined under all warranties applicable to the vehicle or any subpart of the vehicle are unfilled.

**5.9.1 WARRANTY REQUIREMENTS**

Warranties in this document are in addition to any statutory remedies or warranties imposed on the Vendor. Consistent with this requirement the Vendor warrants and guarantees to the Division each complete vehicle, and specific subsystems and components as follows:

**5.9.2 Complete Vehicle**

The vehicle is warranted and guaranteed to be free from defects and related defects for three (3) years or 36,000 miles, whichever comes first, beginning on the first day after the date of final acceptance of each vehicle. During this warranty period, the vehicle shall maintain its structural and functional integrity. The warranty is based on regular operation of the vehicle under the operating conditions prevailing in the Recipient Agencies locales.

REQUEST FOR QUOTATION  
ADA Compliant Lowered Floor Minivans

---

**5.9.2 Warranty of Basic Vehicle Structure**

The Vendor shall warranty the frame and suspension members for three (3) years or 36,000 miles, whichever comes first. This warranty shall not cover air bags, leveling valves, springs or other normal wearing parts. The Vendor is not liable for warranty if the Recipient Agencies voids the warranty as outlined in this Section. If the frame or suspension fails or shows indication of imminent failure, the Recipient Agencies will immediately notify the Vendor of said defect. Within ten (10) calendar days the Vendor will inform the Recipient Agencies on how the Vendor will repair the vehicle. Repair of frame and suspension failures will be the responsibility of the Vendor. Within fifteen (15) calendar days from notification of the defect the Vendor shall begin the repair of the frame and suspension defects. If the vehicle with the reported frame and suspension defect is out of revenue service for more than twenty (20) calendar days because of the reported defect, the Vendor will have to either provide a substitute vehicle of equal seating capacity with wheelchair lift (if applicable) of the same age or newer than the vehicle with the defect or directly reimburse the Recipient Agencies the cost of leasing a substitute vehicle. The maximum daily reimbursement will be \$300. The Vendor will have to continue to provide a substitute vehicle or reimburse the Recipient Agencies until the defect is completely repaired.

**5.9.3 Warranty Locations**

A description of how and by whom warranty service is to be provided in four (4) areas of West Virginia is to be included in the bid proposal. The information should cover both mechanical and body work. All bidders shall provide vendors who will do the warranty of both chassis and body, including vehicle body, air conditioning and wheelchair lifts. The four warranty service areas of West Virginia include: The Northern Panhandle, Eastern Panhandle, Central West Virginia and Southern West Virginia.

**5.9.4 Subsystems and Components**

The subsystems and components are warranted and guaranteed to be free from defects and related defects as follows:

ENGINE:            Three (3) years or 36,000 miles, whichever comes first.

TRANSMISSION:    Three (3) years or 36,000 miles, whichever comes first.

DRIVE AXLE:      Three (3) years or 36,000 miles, whichever comes first.

BRAKE SYSTEM:    Excluding friction material,  
Three (3) years or 36,000 miles  
whichever comes first

REQUEST FOR QUOTATION  
ADA Compliant Lowered Floor Minivans

---

BASIC BODY     Three (3) years or 36,000  
STRUCTURE     miles, whichever comes first..  
INTEGRITY:

AIR CONDITIONING     Three (3) years or 36,000 miles  
SYSTEM:

WHEELCHAIR     Two (2) years  
RAMP SYSTEM:

ALL ADD ON COMPONENTS: Two (2) years, unlimited miles

**5.9.5 VOIDING OF WARRANTY**

The warranty shall not apply to any part or component of the vehicle that has been subject to misuse, negligence, accident, or that has been repaired or altered in any way so as to affect adversely its performance or reliability, except insofar as such repairs were in accordance with the Vendor's maintenance manuals and the workmanship was in accordance with recognized standards of the industry. The warranty shall also be void if the Recipient Agencies fails to conduct normal inspections and scheduled preventative maintenance procedures as recommended in the Vendor's maintenance manuals.

**5.9.6 EXCEPTIONS TO WARRANTY**

The warranty shall not apply to scheduled maintenance items, and items such as tires and tubes, nor to items furnished by the Recipient Agencies such as radios, fare boxes and other auxiliary equipment, except insofar as such equipment may be damaged by the failure of a part or component for which the Vendor is responsible.

**5.9.7 DETECTION OF DEFECTS**

If the Recipient Agency detects a defect within the warranty periods defined in Section 5.10.1 of this Part, it shall promptly notify the Vendor's representative five (5) working days after receipt of notification, the Vendor's representative shall either agree that the defect is in fact covered by warranty, or reserve judgment until the subsystem or component is inspected by the Vendor's representative or is removed and examined at the Recipient Agencies property or at the Vendor's plant. At that time, the status of warranty coverage on the subsystem or component shall be mutually resolved between the Recipient Agency and the Vendor. Work necessary to affect the repairs defined in Section 5.10 of this Part shall commence within ten (10) working days after receipt of notification by the Vendor.

REQUEST FOR QUOTATION  
ADA Compliant Lowered Floor Minivans

---

**5.9.8 SCOPE OF WARRANTY REPAIRS**

When warranty repairs are required, the Recipient Agencies and the Vendor's representative shall agree within five (5) days after notification on the most appropriate course for the repairs and the exact scope of the repairs to be performed under the warranty. If no agreement is obtained within the five (5) day period, the Recipient Agencies reserves the right to commence the repairs in accordance with Section 5.10.

**5.9.9 FLEET DEFECTS**

A fleet defect shall be defined as the failure of any identical items covered by the warranty and the specifications herein, and occurring in a twenty percent (20%) portion of the vehicles purchased under this contract.

The Vendor shall correct a fleet defect under the warranty provision. After correcting defect, the Vendor shall promptly undertake and complete a work program reasonably designed to prevent the occurrence of the same defect in all other vehicles purchased under this contract. The work program shall include inspection and/or correction of the potential or defective parts in all of the vehicles purchased under this contract. The warranty on items determined to be fleet defects shall be extended for the time and/or miles of the original warranty. This extended warranty shall begin on the date of the repair/ replacement for the corrected item.

**5.10 REPAIR PROCEDURES**

**5.10.1 Repair Performance**

At its option, the Division, or its designated representative, may require the Vendor, or its designated representative, to perform warranty covered repairs that are clearly beyond the scope of Recipient Agencies capabilities. All warranty work done by Recipient Agencies personnel will be reimbursed by the Vendor.

**5.10.2 Repairs by Vendor**

If the Recipient Agencies requires the Vendor to perform warranty covered repairs, the Vendor's representative must begin the work necessary to make repairs, within ten (10) working days after receiving notification of a defect from the Recipient Agencies. The Recipient Agencies shall make the vehicle available to complete repairs timely with the Vendor's repair schedule.

The Vendor will provide, at its own expense, all spare parts, tools and space required to complete repairs. At the Recipient Agencies option, the Vendor may be required to complete repairs. At the Recipient Agencies option, the Vendor may be

REQUEST FOR QUOTATION  
ADA Compliant Lowered Floor Minivans

---

required to remove the vehicle from Recipient Agency's property while repairs are being effected. If the vehicle is removed from Recipient Agency's property, repair procedures must be diligently pursued by the Vendor's representative.

**5.10.3 Repairs by Recipient Agencies**

a. **Parts Used**

If the Recipient Agency performs the warranty covered repairs, it shall correct or repair the defect and any related defects using Vendor specified spare parts available from its own stock or those supplied by the Vendor specifically for this repair. Monthly, or at a period to be mutually agreed upon, reports of all repairs covered by this warranty shall be submitted by the Recipient Agency to the Vendor for reimbursement or replacement of parts. The Vendor shall provide forms for these reports.

b. **Vendor Supplied Parts**

The Recipient Agency may request that the Vendor supply new parts for warranty covered repairs being performed by the Recipient Agency. These parts shall be shipped prepaid to the Recipient Agency from any source selected by the Vendor within 10 (ten) working days of receipt of the request for said parts.

c. **Defective Components Return**

The Vendor may request that parts covered by the warranty be returned to the manufacturing plant. The total cost for this action shall be paid by the Vendor. Materials should be returned in accordance with Vendor's instructions.

d. **Reimbursement for Labor**

The Recipient Agencies shall be reimbursed by the Vendor for labor. The amount shall be determined by multiplying the number of man-hours actually required to correct the defect by the current per hour, straight wage rate, plus 53 percent fringe benefits, plus the cost of towing in the vehicle if such action was necessary and if the vehicle was in the normal service area.

These wage and fringe benefit rates shall not exceed the rates in effect in the Recipient Agencies service garage at the time the defect correction is made.

REQUEST FOR QUOTATION  
ADA Compliant Lowered Floor Minivans

---

**c. Reimbursement for Parts**

The Recipient Agencies shall be reimbursed by the Vendor for defective parts and for parts that must be replaced to correct the defect. The reimbursement shall be at the invoice cost of the part(s) at the time of repair and shall include taxes where applicable and 10 percent handling costs.

**5.10.4 WARRANTY AFTER REPLACEMENT/REPAIRS**

If any component, unit, or subsystem is rebuilt or replaced by the Vendor or by the Recipient Agencies personnel, with the concurrence of the Vendor, the subsystem shall have the unexpired warranty period of the original subsystem.

**6 CONTRACT AWARD**

- 6.1 Contract Award:** The Contract is intended to provide Agencies with a purchase price on all Contract Items. The Contract shall be awarded to the Vendor that provides the Contract Items meeting the required specifications for the lowest overall total cost as shown on the Pricing Pages.
- 6.2** The Federal Transit Administration's "Third Party Contracting Circular" (4220.1F), requires grantees (the DPT) to conduct procurements in a manner that prohibits the use of statutorily or administratively imposed In-State or local geographical preferences in the evaluation of bids or proposals, except in those cases where applicable Federal statutes expressly mandate or encourage geographic preference.

Therefore, the In-State vendor preference per West Virginia Code 5A-3-37 shall not apply to this procurement since it is partially or entirely funded with Federal Transit Administration funds.

**7. PRICING PAGE**

- 7.1 Pricing Pages:** Vendor should complete Exhibit A Pricing Page by listing the unit price for each vehicle class, multiplying the unit price by the estimated quantity to arrive at an extended price, and then adding the extended prices for each Class to arrive at a total. All prices quoted are to be in whole dollars and include delivery charges.
- 7.2** Exhibit A Pricing Page contains a list of the Contract Items and estimated purchase volume. The estimated purchase volume for each item represents the approximate volume of anticipated purchases only. No future use of the Contract or any individual item is guaranteed or implied.
- 7.3** Vendor should electronically enter the information into the Pricing Pages through wvOASIS, if available, or as an electronic document.

REQUEST FOR QUOTATION  
ADA Compliant Lowered Floor Minivans

---

- 7.4 Additional agencies, as noted, could purchase from any awarded contract resulting from this bid. Specified deliverables would be as originally advertised, competed, evaluated and awarded.

**8. VENDOR QUALIFICATIONS**

The Vendor must be a person, firm or corporation that:

- a. Has in operation, a manufacturing plant adequate to assure delivery of all equipment within the time specified under the contract.
- b. Has adequate engineering and service personnel, or has the capability to have such personnel, to satisfy any engineering or service problems that may arise during the warranty period.
- c. Has similar vehicles in operation in comparable service for a minimum of one (1) year. The Vendor may be required to furnish a customer list indicating the number of units and dates in service during or equal period of during the bid evaluation period in addition to the requirements under Section 10.2 of these specifications.
- d. In lieu of this requirement, certified results of a shaker test may be requested by the Division during the or equal period to prove the proposed vehicles to be capable of operating the service contemplated for these vehicles.
- e. Has the necessary facilities and financial resources to complete the contract in a satisfactory manner within a required time. The Division shall have the right to conduct a pre-award survey of each Vendor.
- f. Has completed and accurate maintenance, parts, and operators' manuals.

**9. MISCELLANEOUS ITEMS TO BE SUPPLIED WITH BID**

- 9.1 Federal Transit Administration (FTA) Terms and Conditions and Certifications: Current FTA Terms and Conditions are included in this bid and must be met. Certifications for Vehicle Purchases, including Vehicle Pollution Requirements, Federal Motor Vehicle Safety Standards, Debarred Bidders, Disadvantaged Business Enterprise Manufacturers, Buy America Rolling Stock, Restrictions on Lobbying are provided on Bid Form Pages #1 - #10. All bid forms provided shall be properly completed and furnished by the Vendor as part of the bid. Failure to submit any of these forms shall disqualify the bid.
- 9.2 Pre-Award Review – The Vendor shall submit the following items and any further items if requested.

REQUEST FOR QUOTATION  
ADA Compliant Lowered Floor Minivans

---

- A. Complete mechanical description of vehicle, its construction and equipment including manufacturer's model name and/or number. Equipment to be described shall include the wheelchair lift, air conditioner, flip-up seat, and wheelchair securement system, if these items are specified herein.
- B. Proposed interior floor plans, showing detailed dimensions including the location of the wheelchair securement system and stanchions if specified.
- C. Curb weight (empty weight) and gross vehicle weight rating (GVWR) of vehicle.
- D. Samples or paint charts of available exterior paint colors and vinyl.
- E. Description of the warranties the Vendor proposes to furnish for the vehicle and for required ancillary equipment, including a listing of sites where warranty work will be performed.
- F. The location of the nearest depot which will furnish a complete supply of parts and components for the repair and maintenance of the vehicle to be supplied.
- G. Description of the undercoating/rustproofing system, including warranty to be provided.
- H. Identification of the specific location of the place of assembly in the case of a bus or the place of a conversion in the case of a converted van. If the location changes, the Vendor must notify the Division, in which case the Division reserves the right to perform an inspection similar to the pre-award inspection identified. If the results of the inspection are unsatisfactory, the Division may begin the contract termination process through the WV State Purchasing Division.

**9.3 Disadvantaged Business Enterprise (DBE)**

- A. All U.S. Department of Transportation, Federal Transit Administration (FTA) assisted contracts between FTA, the Division, and any Vendor shall include the following language:
  - 1) **Policy** – It is the policy of the U.S. Department of Transportation that Disadvantaged Business Enterprises (DBE) as defined in 49 CFR Part 26 that DBEs shall have the maximum opportunity to participate in the performance of contracts financed in whole or in part with federal funds under this agreement. Consequently, the DBE requirements of 49 CFR Part 26 apply to the agreement.
  - 2) **DBE Obligation** – The recipient or its Vendor agrees to ensure that DBEs as defined in 49 CFR Part 26 shall have the maximum opportunity to participate in the performance of contracts financed in whole or in part with federal funds under this agreement. Consequently, the DBE

REQUEST FOR QUOTATION  
ADA Compliant Lowered Floor Minivans

---

requirements of 49 CFR Part 26 apply to the agreement. In this regard, all recipients or Vendors shall take all necessary and reasonable steps in accordance with 49 CFR Part 26 to ensure that DBEs have the maximum opportunity to compete for and perform contracts.

Recipients and their Vendors shall not discriminate on the basis of race, color, national origin, or sex in the award and performance of U.S. Department of Transportation-assisted contracts.

- 3) The manufacturer of transit vehicles shall certify that it has complied with the requirements of 49 CFR Part 26 (March 4, 1999), Section 26.49, "Transit Vehicle Manufacturers". This certification shall be submitted with responses to this solicitation on **Bid Form #3**.
- 4) The Vendor shall make good faith efforts to replace a DBE subcontractor that is unable to perform, with another DBE subcontractor.
- 5) Where the Vendor is found to have failed to exert sufficient reasonable and good faith efforts to involve DBEs in the work provided, the Division may declare the Vendor noncompliant and in breach of contract.
- 6) The Vendor will keep records and documents for a reasonable time following performance of this contract to indicate compliance with the Division DBE Program. These records and documents will be made available at reasonable times and places for inspection by any authorized representative of the Division and will be submitted to the Division upon request.
- 7) The awarded Vendor agrees to include the following assurance in every subcontract it signs relevant to this contract: The Vendor and each Third Party Subcontractor must not discriminate on the basis of race, color, national origin, or sex in the award and performance of any FTA or U.S. DOT-assisted sub-agreement, third party contract, and third party subcontract, as applicable, and the administration of its DBE program or the requirements of 49 CFR Part 26.

The Vendor and each third party subcontractor must take all necessary and reasonable steps under 49 CFR Part 26 to ensure nondiscrimination in the award and administration of U.S. DOT-assisted sub-agreements, third party contracts and third party subcontracts, as applicable.

Failure by the Vendor and any of its third party contracts or third party subcontractors to carry out the requirements of this subparagraph 13.d(4)(b) is a material breach of this contract, and

REQUEST FOR QUOTATION  
ADA Compliant Lowered Floor Minivans

---

The following remedies, or such other remedy as the Division of Public Transit deems appropriate, include, but are not limited to, withholding payments; assessing sanctions; liquidated damages; and/or disqualifying the Vendor from future bidding as non-responsible.

9.4 **Prohibited Interest** – No employee, officer, board member, agent or their family members of the Division may participate in the selection, award or administration of a contract supported by Federal funds if a real or apparent conflict of interest is involved. Such a conflict could arise when any of the parties mentioned above have a financial or other interest in the Vendor selected for the contract.

9.5 **Civil Rights Requirements** – In connection with the execution of this contract, the following requirements will apply:

A. **Nondiscrimination.** In accordance with Title VI of the Civil Rights Act of 1964, As amended, 42 U.S.C. § 2000d, *et seq.*, Age Discrimination Act of 1975, as amended, 42 U.S.C. §6101, *et. seq.*, Americans With Disabilities Act of 1990, as amended, 42 U.S.C. § 12101, *et. seq.*, and Federal transit law at 49 U.S.C. §5332, as amended, the Vendor agrees that it will not discriminate against any employee or applicant for employment on the basis of race, color, religion, national origin, sex, age or disability. In addition, the Vendor agrees to comply with any other applicable Federal statutes that may be signed into law or regulations that may be promulgated.

B. **Equal Employment Opportunity.** The following equal employment opportunity requirements apply to the underlying contract:

1) **Race. Color. Religion. National Origin. Sex. Disability. Age. Sexual Orientation. Gender Identity or Status as a Parent.** In accordance with Title VI of the Civil Rights Act of 1964, as amended, 42 U.S.C. § 2000e, *et seq.*, and Federal transit laws at 49 U.S.C. § 5332, the Vendor agrees to comply with all applicable equal employment opportunity requirements of the U.S. Department of Labor (US DOL) regulations, “Office of Federal Contract Compliance Programs, Equal Employment Opportunity, Department of Labor,” 41 C.F.R. Parts 60 *et seq.*, (which implement Executive Order Number 11246, “Equal Employment Opportunity”, as amended by Executive Order Number 11375, “Amending Executive Order 11246 Relating to Equal Employment Opportunity,” 42 U.S.C. § 2000e note), and with any applicable Federal statutes, executive orders, regulations, and Federal policies that may in the future affect construction activities undertaken in the course of the Project. The Vendor agrees to take affirmative

REQUEST FOR QUOTATION  
ADA Compliant Lowered Floor Minivans

---

action to ensure that applicants are employed, and that employees are treated during their employment, without regard to their race, color, religion, national origin, sex, disability, age, sexual orientation, gender identity or status as a parent. Such action shall include, but not be limited to, the following: employment, upgrading, demotion or transfer, recruitment or recruitment advertising, layoff or termination; rates of pay or other forms or compensation; and selection for training, including apprenticeship. In addition, the Vendor agrees to comply with any implementing requirements FTA may issue.

- C. The Vendor also agrees to include these requirements in each subcontract financed in whole or in part with Federal assistance provided by FTA, modified only if necessary to identify the affected parties.

**9.6 Buy America Certification** – Vendor agrees to comply with 49 U.S.C. § 5323(j) and 49 CFR Part 661, which provides that Federal funds may not be obligated unless steel, iron, and manufactured products used in FTA-funded projects are produced in the United States, unless a waiver has been granted by FTA or the product is subject to a general waiver. General waivers are listed in 49 CFR 661.7 and include, microcomputer equipment, software, and small purchases (currently less than \$150,000) made with capital, operating, or planning funds. Separate requirements for rolling stock are set out at 49 CFR 661.11. Rolling stock not subject to a general waiver must be manufactured in the United States and have a 60 percent domestic content.

- A. A bidder must submit to the Division the appropriate Buy America certification on Bid Form #4 with all bids on FTA-funded contracts, except those subject to a general waiver. Per FTA requirements, bids that are not accompanied by a completed Buy America certification must be rejected as non-responsive. This requirement does not apply to lower tier subcontractors.
- B. Should the Vendor be declared responsive and low bid, pursuant to Pre-Award and Post Delivery Audit Requirements, the Division will require the Vendor to submit documentation (prior to any award) that lists:
- 1) Component and sub-component parts of the rolling stock to be purchased identified by manufacturer of the parts, their country of origin and costs; and
  - 2) The location of the final assembly point for the rolling stock, including a description of the activities that will take place at the final assembly point and the cost of final assembly.

REQUEST FOR QUOTATION  
ADA Compliant Lowered Floor Minivans

---

- 3) The Vendor shall submit one manufacturer's Federal Motor Vehicle Safety Standards (FMVSS) self-certification sticker providing information that the vehicle quoted complies with relevant FMVSS, or Manufacturer's certified statement that the contracted vehicles will not be subject to FMVSS regulations.
  - 4) Vendor shall submit evidence that it will be capable of meeting the bid specifications.
- C. As required by the Post Delivery Audit Requirement, any successful vendor will be required to furnish the following prior to any completed vehicle being placed into service or before any payment can be made:
- 1) Actual component and sub-component parts of the rolling stock provided, identified by manufacturer of the parts, their country of origin and costs; and
  - 2) Actual location of the final assembly point for the rolling stock provided, including a description of the activities that took place at the final assembly point and the actual cost of final assembly.
- 9.7 **Federal Regulation Changes** – Vendor shall at all times comply with all applicable FTA regulations, policies, procedures and directives, including without limitation those listed directly or by reference in the Master Agreement (FTA MA(22) dated October 1, 2015) <http://www.fta.dot.gov> between the WV Department of Transportation, Division and FTA, as they may be amended or promulgated from time to time during the term of this contract. Vendor's failure to so comply shall constitute a material breach of this contract.
- 9.8 **Debarment and Suspension** – This contract will comply with the requirements of 2 CFR Part 180, subpart C as adopted and supplemented by U.S. DOT regulations at 2 CFR Part 1200. Vendor is required to submit Bid Forms #6 & #7 with bid.

The Division will not enter into any arrangement to participate in the development or implementation of a contract with any Vendor that is debarred or suspended except as authorized by Executive Orders No. 12549, "Uniform Suspension, Debarment or Exclusion of Participant from Procurement or Non-procurement Activity," October 13, 1994, 31 U.S.C. § 6101 note, as amended by Executive Order No. 12689, "Debarment and Suspension," August 16, 1989, 31 U.S.C. § 6101 note, and other applicable federal laws, regulations, or guidance regarding participation with debarred or suspended Vendors.

The Division will review the U.S. GSA "System for Award Management – Lists of parties Excluded from Federal Procurement and Non-procurement Program," <https://www.sam.gov>,

REQUEST FOR QUOTATION  
ADA Compliant Lowered Floor Minivans

---

As required by U.S. DOT regulations, 2 CFR Part 1200. If the Vendor's name is on the list, the Division cannot enter into a contract with a Vendor on the debarred list.

Should an approved Vendor have subcontracts, it is required to include similar provisions in each subcontract and review the SAM at <https://www.sam.gov>, to determine that the subcontractor is not on the debarred or suspended list.

- 9.9 **Restrictions on Lobbying** – Every Vendor who applies or bids for an award of \$100,000 or more shall file the certification of **Bid Form #9** required by 49 CFR Part 20, “New Restrictions on Lobbying.” Each tier certifies to the tier above that it will not and has not used Federal appropriated funds to pay any person or organization for influencing or attempting to influence an officer or employee of any agency, a member of Congress, officer or employee of Congress, or an employee of a member of Congress in connection with obtaining any Federal contract, grant or any other award covered by 31 U.S.C. § 1352. Each tier shall also disclose the name of the registrant under the Lobbying Disclosure Act of 1995 who has made lobbying contacts on its behalf with non-Federal funds with respect to that Federal contract, grant or award covered by 31 U.S.C. §1352. Such disclosures are forwarded from tier to tier, up to the Division.
- 9.10 **Environmental Regulations** – The Vendor agrees it will not use any violating facilities, will report the use of facilities placed on or likely to be placed on the U.S. EPA “List of Violating Facilities,” will report violations of use of prohibited facilities to the Division who will in turn report each violation to FTA and the appropriate EPA Regional Office and will comply with the inspection and other requirements issued pursuant to the Environmental Protection Agency (EPA) regulations (40 CFR, Part 15), which prohibits the use under nonexempt federal contracts, grants, or loans of facilities included on the EPA list of violating facilities.
- 9.11 **Clean Air** – The Vendor agrees to comply with all applicable standards, orders, or regulations issued pursuant to the Clean Air Act, as amended, 42 U.S.C. § 7606 and other requirements of the Clean Air Act, as amended, 42 U.S.C. §§ 7401 – 7671q. The Vendor agrees to report each violation to the Division and understands and agrees that the Division will, in turn, report each violation as required to FTA and the appropriate EPA Regional Office.
- The Vendor also agrees to include these requirements in each subcontract exceeding \$100,000 financed in whole or in part with Federal assistance by FTA.
- 9.12 **Clean Water** – The Vendor agrees to comply with all applicable standards, orders, or regulations issued pursuant to Section 508 of the Clean Water Act, as amended, 33 U.S.C. § 1368, and other provisions of the Clean Water Act, as amended, U.S.C. 33 §§1251 – 1377. The Vendor agrees to report each violation

REQUEST FOR QUOTATION  
ADA Compliant Lowered Floor Minivans

---

to the Division and understands and agrees that the Division will, in turn, report each violation as required to FTA and the appropriate EPA Regional Office.

The Vendor also agrees to include these requirements in each subcontract exceeding \$100,000 financed in whole or in part with Federal assistance provided by FTA.

- 9.13 Energy Conservation Requirements** – The Vendor agrees to comply with mandatory standards and policies relating to energy efficiency which are contained in the State Energy Conservation Plan issued in compliance with the Energy Policy and Conservation Act.
- 9.14 Contract Work Hours and Safety Standards Act** – The Vendor shall comply with Section 102 of the Contract Work Hours and Safety Standards Act (40 USC §§ 3701 *et seq.*, esp. § 3702) as supplemented by Department of Labor Regulations (29 CFR, § 5 & 29 CFR § 1926) as they involve the employment of mechanics and laborers.
- A. Overtime Requirements – No Vendor or subcontractor for any part of the contract work which may require or involve the employment of laborers or mechanics shall require or permit any such laborer or mechanic in any workweek in which he or she is employed on such work to work in excess of forty (40) hours in such workweek unless such laborer or mechanic receives compensation at a rate not less than one and one-half times the basic rate of pay for all hours worked in excess of forty (40) hours in such workweeks.
- B. Violation; Liability for Unpaid Wages; Liquidated Damages – In the event of any violation of the clause set forth in paragraph A of this section, the Vendor and any subcontractor responsible therefore shall be liable for the unpaid wages. In addition, such Vendor and subcontractor shall be liable to the United States for liquidated damages. Such liquidated damages shall be computed with respect to each individual laborer or mechanic, including watchmen and guards, employed in violation of the clause set forth in paragraph A of this section, in the sum of \$10 for each calendar day on which such individual was required or permitted to work in excess of the standard workweek of forty (40) hours without payment of the overtime wages required by the clause set forth in paragraph A of this section.
- C. Withholding for Unpaid Wages and Liquidated Damages – The Division shall upon its own action or upon written request of an authorized representative of the Department of Labor withhold or cause to be withheld, from any moneys payable on account of work performed by the Vendor or subcontractor under any such contract or any other Federal

REQUEST FOR QUOTATION  
ADA Compliant Lowered Floor Minivans

---

contract with the same prime Vendor, or any other federally-assisted contract subject to the Contract Work Hours and Safety Standards Act, which is held by the same prime Vendor, such sums as may be determined to be necessary to satisfy any liabilities of such Vendor or subcontractor for unpaid wages and liquidated damages as provided in the clause set forth in paragraph B of this section.

- D. Subcontracts – The Vendor or subcontractor shall insert in any subcontracts the clauses set forth in this section and also a clause requiring the subcontractors to include these clauses in any lower tier subcontracts. The prime Vendor shall be responsible for compliance by any subcontractor or lower tier subcontractor with the clauses set forth in this section.
- E. Payrolls and Basic Records – Payrolls and basic records relating thereto shall be maintained by the Vendor during the course of the work and preserved for a period of three (3) years thereafter for all laborers and mechanics working at the site of the work (or under the United States Housing Act of 1937, or under the Housing Act of 1949, in the construction or development of the project). Such records shall contain the name, address, and social security number of each such worker, his or her correct classification, hourly rates of wages paid (including rates of contributions or costs anticipated for bona fide fringe benefits or cash equivalents thereof of the types described in Section 1(b)(2)(B) of the Davis-Bacon Act), daily and weekly number of hours worked, deductions made and actual wages paid. Whenever the Secretary of Labor has found under 29 CFR .5(a)(1)(iv) that the wages of any laborer or mechanic include the amount of any costs reasonably anticipated in providing benefits under a plan or program described in Section 1(b)(2)(B) of the Davis-Bacon Act, the Vendor shall maintain records which show that the commitment to provide such benefits is enforceable, that the plan or program is financially responsible, and that the plan or program has been communicated in writing to the laborers or mechanics affected, and records which show the costs anticipated or the actual cost incurred in providing such benefits.

Vendors employing apprentices or trainees under approved programs shall maintain written evidence of the registration of apprenticeship programs and certification of the training programs, the registration of the apprentices and trainees, and the ratios and wage rates prescribed in the applicable programs.

- 9.15 **Hold Harmless** – The Vendor agrees to protect, defend, indemnify and hold the State of West Virginia, the Division, its officers, employees and agents free and harmless from and against any and all losses, penalties, damages, settlements, costs, charges, professional fees or other expenses or liabilities of every kind and

REQUEST FOR QUOTATION  
ADA Compliant Lowered Floor Minivans

---

character arising out of or relating to any and all claims, liens, demands, obligations, actions, proceedings or causes of action of every kind and character in connection with or arising directly or indirectly out of this Contract and/or the performance hereof. Without limiting the generality of the foregoing, and all such claims, etc., relating to personal injury, infringement of any patent, trademark, copyright (or application for any thereof) or of any other tangible or intangible personal or property right, or actual or alleged violation of any applicable statute, ordinance, administrative order, rule or regulation, or decrees of any court, shall be included in the indemnity hereunder. The Vendor further agrees to investigate, handle, respond to, provide defense for and defend any such claims, etc., at his/her sole expense and agrees to bear all other costs and expenses related thereto, even if such claim is groundless, false or fraudulent.

**9.16 Program Fraud and False or Fraudulent Statements and Related Acts**

The Vendor acknowledges that the provisions of the Program Fraud Civil Remedies Act of 1986, as amended 31 U.S.C. §§ 3801 *et seq.* and U.S. Department of Transportation regulations, "Program Fraud Civil Remedies," 49 C.F.R. Part 31, apply to its actions pertaining to this Contract. Upon execution of the underlying contract, the Vendor certifies or affirms the truthfulness and accuracy of any statement it has made, it makes, it may make, or causes to be made, pertaining to the underlying contract or the FTA assisted project for which this Contract work is being performed. In addition to other penalties that may be applicable, the Vendor further acknowledges that if it makes, or causes to be made, a false, fictitious, or fraudulent claim, statement, submission, or certification, the Federal Government reserves the right to impose the penalties of the Program Fraud Civil Remedies Act of 1986 on the Vendor to the extent the Federal Government deems appropriate.

The Vendor also acknowledges that if it makes, or causes to be made, a false, fictitious, or fraudulent claim, statement, submission, or certification to the Federal Government under a contract connected with a project that is financed in whole or in part with Federal assistance originally awarded by FTA under the authority of 49 U.S.C. § 5307, the Government reserves the right to impose the penalties of 18 U.S.C. § 1001 and 49 U.S.C. § 5307(n)(1) on the Vendor, to the extent the Federal Government deems appropriate.

The Vendor agrees to include the above two clauses in each subcontract financed in whole or in part with Federal assistance provided by FTA. It is further agreed that the clauses shall not be modified, except to identify the subcontractor who will be subject to the provisions.

**9.17 Incorporation of FTA Terms**

The preceding provisions include, in part, certain Standard Terms and Conditions required by the U.S. Department of Transportation, whether or not expressly set

REQUEST FOR QUOTATION  
ADA Compliant Lowered Floor Minivans

---

forth in the preceding Contract provisions. All contractual provisions required by DOT, as set forth in FTA Circular 4220.1F, dated November 1, 2008, and are hereby incorporated by reference. Anything to the contrary herein notwithstanding, all FTA mandated terms shall be deemed to control in the event of a conflict with other provisions contained in this Contract. The Vendor shall not perform any act, fail to perform any act, or refuse to comply with any DPT requests which would cause DPT to be in violation of the FTA terms and conditions.

**9.18 Access to Records**

The Vendor agrees to permit DPT, the Secretary of the US DOT and the Comptroller General of the United States, or their authorized representatives, to inspect all Contract work, materials, payrolls and other data and records with regard to the Contract. The Vendor also agrees to permit an audit of the books, records, and accounts of the Vendor and its subcontractors.

**9.19 Accessibility**

Vendor agrees that any vehicles provided shall be in accordance with the 42 U.S.C. Sections 12101 *et seq.*, and US DOT regulations, "Transportation Services for Individuals with Disabilities Act (ADA)," 49 CFR Part 37; and Joint U.S. Architectural and Transportation Barriers Compliance Board (U.S. ATBCB) and U.S. DOT regulations, "Americans with Disabilities (ADA) Accessibility Specifications for Transportation Vehicles," 36 CFR Part 1192 and 49 CFR Part 38.

**9.20 Air Pollution and Fuel Economy**

Vendor is to ensure compliance with applicable Federal air pollution control and fuel economy regulations, such as EPA regulations, "Control of Air Pollution from Mobile Sources," 40 CFR Part 85; EPA regulations, "Control of Emissions from New and In-Use Vehicles," 40 CFR Part 86; and EPA regulations, "Fuel Economy and Greenhouse Gas Exhaust Emissions of Motor Vehicles" 40 CFR Part 600.

**9.21 Bid Protest Procedures**

Vendors have the option of protesting certain decisions made by the Purchasing Division. Please refer to the following link for Vendor Protest Procedures under Section 6.8.

<http://www.state.wv.us/admin/purchase/vrc/vpg/VendorProcurementGuide.pdf>

REQUEST FOR QUOTATION  
ADA Compliant Lowered Floor Minivans

---

**9.22 Appeals to the Federal Transit Administration (FTA)**

Under the Federal Transit Administration's Circular 4220.1F, the Federal Transit Administration's (FTA's) appeals process for reviewing protests of a recipient's procurement decisions are:

- 1) Requirements for the Protester – The protester must:
  - a) Qualify as an “Interested Party” – Only an “interested party” qualifies for FTA review of its appeal. An “interested party” is a party that is an actual or prospective bidder or offeror whose direct economic interest would be affected by the award or failure to award the contract at issue.
    - i) Subcontractors – A subcontractor does not qualify as an “interested party” because it does not have a direct economic interest in the results of the procurement.
    - ii) Consortia//Joint Ventures/Partnerships/Teams – An established consortium, joint venture, partnership, or team that is an actual bidder or offeror and is acting in its entirety, would qualify as an “interested party” because it has a direct economic interest in the results of the procurement. An individual member of a consortium, joint venture, partnership, or team, acting solely in its individual capacity, does not qualify as an “interested party” because it does not have a direct economic interest in the results of the procurement.
    - iii) Associations or Organizations – An association or organization that does not perform contracts does not qualify as an “interested party” because it does not have a direct economic interest in the results of the procurement.
  - b) Exhaust Administrative Remedies – The protester must exhaust its administrative remedies by pursuing the WV Purchasing Division protest procedures to completion before appealing their decision to FTA.
  - c) Appeal Within Five (5) Days – The protester must deliver its appeal to the FTA Regional Administrator, Region III, 1760 Market Street, Suite 500, Philadelphia, PA, 19103-4124 within five (5) working days of the date when the protester has received actual or constructive notice of the WV Purchasing Division's final decision. Likewise, the protester must provide its appeal to the same address within five (5) working days of the date when the protester has identified other grounds for appeal to FTA. For example, other grounds for appeal include the DPT's failure to have or failure to comply with the WV Purchasing Division's protest procedures or failure to review the protest.

REQUEST FOR QUOTATION  
ADA Compliant Lowered Floor Minivans

---

- 2) Extent of FTA Review – FTA limits its reviews of protests to:
- a) Failure of DPT to have or adhere to WV Purchasing Division written bid protest procedures, or failure of DPT to review a complaint or protest.
  - b) Alleged violations on other grounds are under the jurisdiction of the appropriate State or local administrative authorities.
  - c) Alleged violations of a specific Federal Law or regulation that provides an applicable complaint procedure shall be submitted and processed in accordance with that Federal Law or regulation. See, e.g., Buy America Requirements, 49 C.F.R. Part 661 (Section 661.15); Participation by Minority Business Enterprise in Department of Transportation Programs, 49 C.F.R. Section 26.89.

FTA will exercise discretionary jurisdiction over those appeals involving issues important to FTA’s overall public transportation program. FTA will refer violations of Federal law for which it does not have primary jurisdiction to the Federal authority having proper jurisdiction.

- 3) FTA Determinations to Decline Protest Reviews – FTA’s determination to decline jurisdiction over a protest does not mean that FTA approves of or agrees with WV Purchasing Division’s decision or that FTA has determined the contract is eligible for Federal participation. FTA’s determination means only that FTA does not consider the issues presented to be sufficiently important to FTA’s overall program that FTA considers a review to be required.

**10. ORDERING AND PAYMENT TO VENDOR**

**10.1 ORDERING:**

Vendor shall accept orders by regular mail, facsimile, e-mail, or any other written forms of communication.

**10.2 Payment**

When submitting invoices for payment to the Division, the Vendor shall be required to provide an original typed invoice. The following items shall appear on the invoice:

- 1) Vendor’s Federal Employee Identification Number (FEIN)
- 2) Order number

REQUEST FOR QUOTATION  
ADA Compliant Lowered Floor Minivans

---

3) Invoice should reflect the base vehicle cost and any applicable options With unite cost. NOTE: Two invoices shall be submitted for each vehicle , one for 90% and one for 10%.

4) Submit all invoices to:  
Division of Multimodal Transportation Facilities-Public Transit  
Building 5, Room 663  
1900 Kanawha Blvd., East  
Charleston, West Virginia 25305

**10.2.1** Payment of 90% of the total cost shall be paid upon conditional acceptance of the vehicle(s).

**10.2.2** Conditional acceptance of the vehicle(s) by the Division shall be made upon completion of inspection by the Division of Public Transit under Section 17 of this RFQ.

**10.2.3** Under the conditional acceptance of the vehicle(s) provided, the Division of Public Transit shall retain 10% of the total cost per vehicle until all vehicles provided have been in actual service for thirty (30) days.

**10.2.4** In the event any vehicle is found to be unacceptable during the thirty (30) day period of conditional acceptance, the Division shall furnish to the Vendor, in writing, a letter of non- acceptance detailing any and all deficiencies.

**10.2.5** Final acceptance on each vehicle shall be made by the Division of Public Transit in writing upon completion of the period of conditional acceptance and/or after any and all deficiencies have been corrected.

**10.2.6** Final acceptance shall be made on each individual vehicle provided. (Some vehicles may be accepted, while acceptance of others remains pending.)

**10.2.7** Final acceptance of each vehicle shall be provided in writing by the Director of the Division or his/her authorized representative.

**10.2.8** All warranties as described in this contract shall begin with the first day after the date of final acceptance of each vehicle. **Vendor shall furnish Notification of Delayed Delivery Date of In-Transit Mileage Accumulation Forms for completion by the Division upon acceptance of the vehicle.**

**10.2.9** Prompt Payment – The prime Vendor agrees to pay each sub-contractor

REQUEST FOR QUOTATION  
ADA Compliant Lowered Floor Minivans

---

under this prime contract for satisfactory performance of its contract no later than fifteen (15) days from the receipt of each payment the prime Vendor receives from the Division. The Vendor agrees further to return retainage payments to each sub-contractor within fifteen (15) days after the sub-contractor's work is satisfactorily completed. Any delay of postponement of payment from the above referenced time frame may occur only for good cause following written approval from the Division. This clause applies to both DBE and non-DBE sub-contractors.

**11. DELIVERY AND RETURN:**

**11.1 Delivery Time and Location:** Vendors shall specify approximate delivery dates when submitting bids. Delivery of the vehicle shall be completed within 150 days after receipt of executed contract documents. Vendor shall ship all orders in accordance with the above schedule and shall not hold orders until a minimum delivery quantity is met.

**11.2 Late Delivery:** The Division must be notified in writing if delivery is delayed for any reason. The request for extension must be received by the Division no less than ten (10) days prior to the originally planned vehicle delivery date and must include detailed justification for the length of the time extension. Any delay in delivery that could cause harm to an Agency will be grounds for cancellation of the delayed order, and/or obtaining the items ordered from a third party.

Any Agency seeking to obtain items from a third party under this provision must first obtain approval of the Purchasing Division.

**11.3** Delivery shall be FOB destination to designated transit provider or:

Kanawha Valley Regional Transit Authority (KRT)  
1550 4<sup>th</sup> Avenue,  
Charleston, WV 25324

Vendor must contact KRT 24 hours before delivery at 304-343-7594. Delivery will be accepted Monday through Friday, between 9 a.m. and 2 p.m. exclusive of State holidays.

Any delay in delivery resulting from the common carriers operations, accidents, or mechanical failures in route shall be construed as a cause beyond the Vendor's control.

However, the Vendor shall have the responsibility of releasing the vehicle to the common carrier in time to reach the delivery site under normal delivery conditions.

**11.4** In case the delivery of the complete vehicle shall be necessarily delayed because of

REQUEST FOR QUOTATION  
ADA Compliant Lowered Floor Minivans

---

strike, Injunction, civil disturbance, government controls, or by reason of any cause or circumstances beyond the control of the Vendor, as detailed in writing by the Vendor, the term of completion of delivery shall be extended by a number of days to be determined in each instance by mutual agreement of the Division of Public Transit and Vendor.

- 11.5** If the vehicle is delivered over-the-road, a written report shall be submitted by the driver to the Division listing all incidents and unusual vehicle performance during the trip.

Should any service or repair be required during delivery, a comprehensive report shall be submitted to the Executive Director of the Division describing the nature of the service or repair and the cause.

- 11.6** Prior to acceptance, the Vendor shall have total risk of loss of the vehicle, including any damage sustained during the Vendor's driveway operation. Drivers shall keep a maintenance log enroute and it shall be delivered to the Division with the vehicle.

## **12. ACCEPTANCE TESTS**

### **12.1 Responsibility**

Fully-documented tests shall be conducted on each production vehicle following manufacture to determine its acceptance to the Division. These acceptance tests shall include pre-delivery inspections and testing by the Division after the vehicles have been delivered.

### **12.2 Pre-Delivery Tests**

The Vendor shall conduct acceptance tests at its plant on each vehicle following completion of manufacture and before delivery to the Division. These pre-delivery tests shall include visual and measured inspections, as well as testing the total vehicle operation. The tests shall be documented. Additional tests may be conducted at the Vendor's discretion to ensure that the completed vehicles have attained the desired quality and have met the requirements of Section 3: Specifications. This additional testing shall be recorded on appropriate test forms provided by the Vendor.

The pre-delivery tests will be scheduled and conducted with sufficient notice so that they may be witnessed by the resident inspectors, who may accept or reject the results of the tests. The results of pre-delivery tests, and any other tests, will be filed with the assembly inspection records for each vehicle. The under-floor equipment will be made available for inspection by the

REQUEST FOR QUOTATION  
ADA Compliant Lowered Floor Minivans

---

resident inspectors, using a hoist. A scaffold, or elevated platform will be provided by the Vendors to easily and safely inspect vehicle roofs. Delivery of each vehicle will require written authorization of a resident inspector. Authorization forms for the release of each vehicle for delivery will be provided by the Vendor. An executed copy of the authorization will accompany the delivery of each vehicle.

**12.3 Inspection - Visual and Measured**

Visual and measured inspections shall be conducted with the vehicle in a static condition. The purpose of the inspection testing is to verify overall dimensional and weight requirements, to verify that required components are included and are ready for operation, and to verify that components and subsystems that are designed to operate with the vehicle in a static condition do function as designed.

**13. Total Vehicle Operation**

Total vehicle operations shall be evaluated during road tests. The purpose of the road tests is to observe and verify the operation of the vehicle as a system and to verify the functional operation of the subsystem that can be operated only while the vehicle is in motion.

Each vehicle shall be driven for a minimum of 15 miles during the road tests. Observed defects shall be recorded on the test forms. The vehicle shall be retested when defects are corrected and adjustments are made. This process shall continue until defects or required adjustments are no longer detected. Results shall be pass/fail for these vehicle operation tests.

**14. Final Pre-Delivery Inspection:** Prior to delivery, all vehicles must be thoroughly inspected and serviced in compliance with the manufacturer's prescribed procedures which includes but is not limited to:

- a. Complete vehicle lubrication;
- b. Confirm oil level, fill crank case as needed, top off all fluids;
- c. Adjust engine to proper operating condition;
- d. Verify tire pressure and correct as necessary;
- e. Check front end alignment or four wheel alignment, perform alignment, and balance all tires;

REQUEST FOR QUOTATION  
ADA Compliant Lowered Floor Minivans

---

- f. Wash/Clean interior and exterior of vehicle. Remove all unnecessary tags, stickers (including window stickers), papers, tags, etc.
- g. Upon delivery, the vehicles fuel tanks shall be full of fuel;
- h. Affix a valid West Virginia Inspection Sticker to the windshield. The vehicle must be inspected in the month delivered.
- i. No dealer insignia or other advertising shall be affixed to the vehicle or appear on any accessory such as mud flaps, bumpers, deck lids, etc. Vehicles delivered with such advertising will be rejected;
- j. Perform operational checks which will cover all controls, systems, and devices, doors, windows, accessories, and road testing of the completed vehicle. Vehicle shall be driven at various speeds; brakes tested for dependability, vehicle checked for rattles, squeaks and must be in compliance with pre-delivery inspection/servicing procedures and make adjustments as necessary.

**15. Post-Delivery Tests** The Division shall, within fifteen (15) calendar days of notice from Vendor that vehicle is ready to be inspected for conditional acceptance, proceed with its inspection of vehicle for conditional acceptance. The Division will conduct acceptance tests on each delivered vehicle. The purpose of these tests is to identify defects that have become apparent between the time of vehicle release and delivery to the Division. The post-delivery tests shall include visual inspection and vehicle operations. The road tests for total vehicle operation are similar to those conducted at the Vendor's plant. Operational deficiencies of each vehicle shall be identified and recorded.

Vehicles that fail to pass the post-delivery tests are subject to non-acceptance. The Division shall record details of all defects and shall notify the Vendor of non-acceptance of each vehicle within 5 days after completion of the tests.

**16. Conditional Acceptance of Vehicle's** The vehicle shall undergo the Division's acceptance test. If the vehicle passes these tests, conditional acceptance of the vehicle by the Division occurs on the fifteenth day after delivery. Acceptance may occur earlier if the Division notifies the Vendor of early acceptance. If the vehicle fails these tests, it shall not be accepted until the repairs have been made.

**16.1 Repairs After Non-Acceptance**

The Division may require the Vendor, or its designated representative, to perform the repairs after non-acceptance or the work may be done by the Transit Authority or Recipient Agency's personnel with reimbursement by the Vendor.

REQUEST FOR QUOTATION  
ADA Compliant Lowered Floor Minivans

---

**17.1.1 Repairs by Vendor**

If the Transit Authority or Recipient Agency requires the Vendor to perform repairs after non-acceptance of the vehicle, Vendor's representative must begin work within five (5) working days after receiving notifications from the Division or Transit Authority of failure of acceptance tests. The Transit Authority or Recipient Agency shall make the vehicle available to complete repairs timely with the Vendor's repair schedule.

The Vendor shall provide, at its own expense, all spare parts, tools and space required to complete the repairs. At the Transit Authority or Recipient Agency's option, the Vendor may be required to remove the vehicle from their property. The repair procedure must be diligently pursued by the Vendor's representatives and the Vendor shall assume risk of loss while the vehicle is under its control.

**17.1.2 Repairs by Transit Authority or Recipient Agency**

- a) **Parts Used.** If the Transit Authority or Recipient Agency decides to perform the repairs after non-acceptance of the vehicle, it shall correct or repair the defect and any related defects using Vendor specified parts available from its own stock or those supplied by the Vendor specifically for this repair.  
  
Monthly, or at a period to be mutually agreed upon, reports of all repairs covered by this procedure shall be submitted by the Transit Authority or Recipient Agency to the Vendor for reimbursement or replacement of parts. The Vendor shall provide forms for these reports.
- b) **Vendor Supplied Parts.** If the Vendor supplies parts for repairs being performed by the Transit Authority or Recipient Agency, after non-acceptance of the vehicle, these parts shall be shipped prepaid to the Transit Authority or Recipient Agency from any source selected by the Vendor within ten (10) working days after receipt of the request for said parts, provided said parts are available for shipment.
- c) **Return of Defective Components.** The Vendor may request that parts covered by this provision be returned to the manufacturing plant. The total cost for this action shall be paid by the Vendor.
- d) **Reimbursement for Labor.** The Transit Authority or Recipient Agency shall be reimbursed by the Vendor for labor. The amount shall be determined by multiplying the number of actual "man-hours" straight wage rate plus 53 percent fringe benefits, plus the cost of towing in the

REQUEST FOR QUOTATION  
ADA Compliant Lowered Floor Minivans

---

vehicle if such action was necessary. These wage and fringe benefit rates shall not exceed the rates in effect at the Transit Authority or Recipients Agency's service garage at the time the defect correction is made.

- e) **Reimbursement for Parts.** The Transit Authority or Recipient Agency shall be reimbursed by the Vendor for defective parts that must be replaced to correct the defect. The reimbursement shall include taxes where applicable and ten (10) percent handling cost.

**16.1.3 Delivery Payment/Risk of Loss:** Standard order delivery shall be F.O.B. destination to the Agency's designated location. Vendor shall include the cost of standard order delivery charges in its bid pricing/discount and is not permitted to charge the Agency separately for such delivery.

**17. VENDOR DEFAULT:**

**17.1** The Following shall be considered a vendor default under this Contract.

**18.1.1** Failure to provide Contract Items in accordance with the requirements contained herein.

**18.1.2** Failure to comply with other specifications and requirements contained herein.

**18.1.3** Failure to comply with any laws, rules, and ordinances applicable to the Contract Services provided under this Contract.

**18.1.4** Failure to remedy deficient performance upon request.

**17.2** The Following remedies shall be available to Agency upon default.

**18.2.1** Immediate cancellation of the Contract.

**18.2.2** Immediate cancellation of one or more release orders issued under this Contract.

- i. Any other remedies available in law or equity.

REQUEST FOR QUOTATION  
ADA Compliant Lowered Floor Minivans

---

**18. MISCELLANEOUS:**

- 18.1 No Substitutions:** Vendor shall supply only Vehicles as submitted in response to the Solicitation unless a contract modification is approved in accordance with the provisions contained in this Contract.
- 18.2 Vendor Supply:** Vendor must carry sufficient inventory of the Contract Items being offered to fulfill its obligations under this Contract. By signing its bid, Vendor certifies that it can supply the Contract Items contained in its bid response.
- 18.3 Contract Manager:** During its performance of this Contract, Vendor must designate and maintain a primary contract manager responsible for overseeing Vendor's responsibilities under this Contract. The Contract manager must be available during normal business hours to address any customer service or other issues related to this Contract. Vendor should list its Contract manager and his or her contact information below.

**Contract Manager:** \_\_\_\_\_

**Telephone Number:** \_\_\_\_\_

**Fax Number:** \_\_\_\_\_

**Email Address:** \_\_\_\_\_

**18.4 NOTIFICATION OF FEDERAL PARTICIPATION**

Federal funding for this project is being provided by the Federal Transit Administration through various CFDA grants for 80% of the project cost. CFDA grants will be specified after award.

REQUEST FOR QUOTATION  
ADA Compliant Lowered Floor Minivans

19. PROPOSED FLOOR PLANS

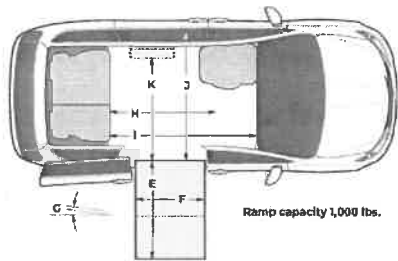
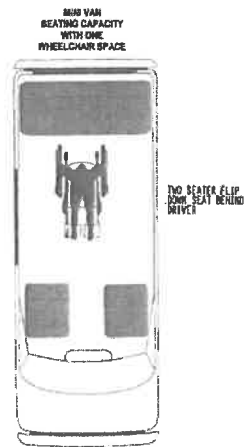

Revised 03/13/2024

REQUEST FOR QUOTATION  
ADA Compliant Lowered Floor Minivans

---

20. **REQUIRED BID FORMS**

The following certifications must be properly **completed and furnished by the bidder as part of the bid**. Failure to submit any of these certifications **shall deem the bid non-responsive**.

*A required documentation checklist has been provided for bidder's usage.*

REQUEST FOR QUOTATION  
ADA Compliant Lowered Floor Minivans

---

**BID FORM #1**

**REQUIRED BID FORM TO BE SUBMITTED WITH BID**

Location(s) of the Technical Service Representative(s) and parts distribution center(s) closest or in the State of West Virginia.

**Location(s) of the technical service representative(s).**

Name: \_\_\_\_\_

Address: \_\_\_\_\_  
\_\_\_\_\_

Telephone: \_\_\_\_\_

Name: \_\_\_\_\_

Address: \_\_\_\_\_  
\_\_\_\_\_

Telephone: \_\_\_\_\_

**Location(s) of parts distribution center(s).**

Name: \_\_\_\_\_

Address: \_\_\_\_\_  
\_\_\_\_\_

Telephone: \_\_\_\_\_

Name: \_\_\_\_\_

Address: \_\_\_\_\_  
\_\_\_\_\_

Telephone: \_\_\_\_\_

REQUEST FOR QUOTATION  
ADA Compliant Lowered Floor Minivans

---

**BID FORM #2**

**CERTIFICATION FOR AIR & WATER POLLUTION  
REQUIRED BID FOR TO BE SUBMITTED WITH BID**

The Vendor certifies that the vehicles proposed:

**ARE** \_\_\_\_\_ in compliance with the regulations in 40 CFR Part 85, 40 CFR Part 86, 40 CFR Part 600, Clean Water Act and the air/water pollution criteria established by the Environmental Protection Agency of the United States Government.

**ARE NOT** \_\_\_\_\_ in compliance with the regulations in 40 CFR Part 85, 40 CFR Part 86, 40 CFR Part 600, Clean Water Act and the air/water pollution criteria established by the Environmental Protection Agency of the United States Government.

\_\_\_\_\_  
Date

\_\_\_\_\_  
Authorized Signature

\_\_\_\_\_  
Title

\_\_\_\_\_  
Company Name

REQUEST FOR QUOTATION  
ADA Compliant Lowered Floor Minivans

---

**BID FORM #3**

**DISADVANTAGED BUSINESS ENTERPRISE  
VENDORS/ MANUFACTURERS CERTIFICATION**

**REQUIRED BID FOR TO BE SUBMITTED WITH BID**

**(Check appropriate statement)**

\_\_\_\_\_ The Vendor, if a transit vehicle manufacturer, hereby certifies that it has complied with the requirements of 49 CFR Section 26.49 by submitting an annual DBE goal to the Federal Transit Administration (FTA). The goal has either been approved or not disapproved by FTA.

\_\_\_\_\_ The Vendor, if a non-manufacturing supplier, hereby certifies that the manufacturer of the transit vehicle to be supplied has complied with the above-referenced requirement of 49 CFR Section 26.49.

\_\_\_\_\_  
Date

\_\_\_\_\_  
Authorized Signature

\_\_\_\_\_  
Title

\_\_\_\_\_  
Company Name

REQUEST FOR QUOTATION  
ADA Compliant Lowered Floor Minivans

---

**BID FORM #4**

**BUY AMERICA CERTIFICATION  
ROLLING STOCK  
REQUIRED BID FOR TO BE SUBMITTED WITH BID**

**Certificate of Compliance**

The bidder or offeror hereby certifies that it will comply with the requirements of section 165(b) (3), of the Surface Transportation Assistance Act of 1982, as amended, and the applicable regulations of 49 CFR 661.11:

\_\_\_\_\_  
Date

\_\_\_\_\_  
Authorized Signature

\_\_\_\_\_  
Company Name

\_\_\_\_\_  
Name

\_\_\_\_\_  
Title

**Certificate for Non-Compliance**

The bidder or offeror hereby certifies that it cannot comply with the requirements of section 165(b) (3) of the Surface Transportation Assistance Act of 1982, as amended, but may qualify for an exception to the requirement consistent with section 165(b) (2) or (b) (4) of the Surface Transportation Assistance Act, as amended, and the applicable regulations in 49 CFR 661.7.

\_\_\_\_\_  
Date

\_\_\_\_\_  
Authorized Signature

\_\_\_\_\_  
Company Name

\_\_\_\_\_  
Name

\_\_\_\_\_  
Title

**BID FORM #5**

Revised 03/13/2024

REQUEST FOR QUOTATION  
ADA Compliant Lowered Floor Minivans

---

**FEDERAL MOTOR VEHICLE  
SAFETY STANDARDS CERTIFICATION**

**REQUIRED BID FORM TO BE SUBMITTED WITH BID**

The vendor hereby certifies that it shall submit, as required by Title 49 of the CFR, Part 663 - Subpart D, it's self-certification information stating that the vehicle(s) will comply with the relevant Federal Motor Vehicle Safety Standards issued by the National Highway Traffic Safety Administration in Title 49 of the Code of Federal Regulations, Part 571.

\_\_\_\_\_  
Date

\_\_\_\_\_  
Authorized Signature

\_\_\_\_\_  
Title

\_\_\_\_\_  
Company Name

REQUEST FOR QUOTATION  
ADA Compliant Lowered Floor Minivans

---

**BID FORM #6**  
**U.S. Comptroller's Debarment List Certification**  
**REQUIRED BID FOR TO BE SUBMITTED WITH BID**

\_\_\_\_\_ hereby certifies that it

\_\_\_\_\_ **IS or**

\_\_\_\_\_ **IS NOT** (specify one) included on the U.S. GSA's debarment and suspension information available at <https://www.sam.gov>.

\_\_\_\_\_  
Date

\_\_\_\_\_  
Authorized Signature

\_\_\_\_\_  
Title

\_\_\_\_\_  
Company Name

REQUEST FOR QUOTATION  
ADA Compliant Lowered Floor Minivans

---

**BID FORM #7**

**REQUIRED BID FOR TO BE SUBMITTED WITH BID**  
**CERTIFICATION OF PRIMARY PARTICIPANT REGARDING**  
**DEBARMENT, SUSPENSION, AND OTHER RESPONSIBILITY MATTERS**

The Primary Participant (applicant for an FTA grant or cooperative agreement, or potential contractor for a major third party contract),

\_\_\_\_\_ (COMPANY NAME) certifies to the best of its knowledge and belief, that it and its principals:

1. Are not presently debarred, suspended, proposed for debarment, declared ineligible, or voluntarily excluded from covered transactions by any Federal department or agency;
2. Have not within a three-year period preceding this proposal been convicted of or had a civil judgment rendered against them for commission of fraud or a criminal offense in connection with obtaining, attempting to obtain, or performing a public (Federal, State or local) transaction or contract under a public transaction; violation of Federal or State antitrust statutes or commission of embezzlement, theft, forgery, bribery, falsification or destruction of records, making false statements, or receiving stolen property.
3. Are not presently indicted for or otherwise criminally or civilly charged by a governmental entity (Federal, State or local) with commission of any of the offenses enumerated in paragraph (2) of this certification; and
4. Have not within a three-year period preceding this application/proposal had one or more public transactions (Federal, State or local) terminated for cause or default.

If the primary participant (applicant for an FTA grant, or cooperative agreement, or potential third party contractor) is unable to certify to any of the statements in this certification, the participant shall attach an explanation to this certification.)

THE PRIMARY PARTICIPANT (APPLICANT FOR AN FTA GRANT OR COOPERATIVE AGREEMENT, OR POTENTIAL CONTRACTOR FOR A MAJOR THIRD PARTY CONTRACT), \_\_\_\_\_, CERTIFIES OR AFFIRMS THE TRUTHFULNESS AND ACCURACY OF THE CONTENTS OF THE STATEMENTS SUBMITTED ON OR WITH THIS CERTIFICATION AND UNDERSTANDS THAT THE PROVISIONS OF 31 U.S.C. SECTIONS 3801 ET SEQ. ARE APPLICABLE THERETO.

\_\_\_\_\_  
Signature and Title of Authorized Official

Revised 03/13/2024

REQUEST FOR QUOTATION  
ADA Compliant Lowered Floor Mini-Van

---

**BID FORM #8**  
REQUIRED BID FOR TO BE SUBMITTED WITH BID

***VENDOR'S CERTIFICATION OF  
UNDERSTANDING AND ACCEPTANCE***

The Vendor hereby certifies that all Technical Specifications and Contract Terms and Conditions have been carefully reviewed, are fully understood and shall be adhered to in performance and completion of any contract resulting from this bid.

\_\_\_\_\_  
Date

\_\_\_\_\_  
Authorized Signature

\_\_\_\_\_  
Title

\_\_\_\_\_  
Company Name

**SPECIFICATION COMPLIANCE**

NOTE: Please check if what is offered is in exact compliance with specifications. **Any discrepancies must be listed as an attachment to the bid proposal. Exact dimensions and/or descriptions must be provided as a part of the Vendor's bid proposal when submitted.**

\_\_\_\_\_ Bid proposal submitted meets and/or exceeds all specification requirements.

\_\_\_\_\_ Bid proposal submitted contains deviations from specification requirements. Detailed descriptions of these deviations have been provided with this bid proposal.

REQUEST FOR QUOTATION  
ADA Compliant Lowered Floor Mini-Van

---

**BID FORM #9**  
**REQUIRED BID FOR TO BE SUBMITTED WITH BID**

**CERTIFICATION OF RESTRICTIONS ON LOBBYING**

The undersigned (Vendor, Contractor) certifies, to the best of his or her knowledge and belief, that:

1. No Federal appropriated funds have been paid or will be paid by or on behalf of the undersigned, to any person for influence or attempt to influence an officer or employee of any Federal agency, a Member of Congress, an officer or employee of Congress, or an employee of a Member of Congress regarding the award of a Federal grant, loan (including a line of credit), cooperative agreement, loan guarantee, or loan insurance, or the extension, continuation, renewal, amendment, or modification of any Federal grant, loan (including a line of credit), cooperative agreement, loan guarantee, or loan insurance.
2. If any funds other than Federal appropriated funds have been or will be paid to any person to influence or attempt to influence an officer or employee of any Federal agency, a Member of Congress, an officer or employee of Congress, or any employee of a Member of Congress in connection with any application for a Federal grant, loan (including a line of credit), cooperative agreement, loan guarantee, or loan insurance, the undersigned assures that it will complete and submit Standard Form-LLL, "Disclosure of Lobbying Activities," Rev. 7-97; and
3. The undersigned understands that the language of this certification shall be included in the award documents for all sub awards at all tiers (including subcontracts, sub grants, sub agreements, and contracts under grants, loans (including a line of credit), cooperative agreements, loan guarantees, and loan insurance.

Undersigned understands that this certification is a material representation of fact upon which reliance is placed by the Federal government and that submission of this certification is a prerequisite for providing a Federal grant, loan (including a line of credit), cooperative agreement, loan guarantee, or loan insurance for a transaction covered by 31 U.S.C. 1352. The undersigned also understands that any person who fails to file a required certification shall be subject to a civil penalty of not less than \$10,000 and not more than \$100,000 for each such failure.

The (Vendor, Contractor) \_\_\_\_\_, certifies or affirms the truthfulness and accuracy of each statement of its certification and disclosure, if any. In addition, the (Vendor, Contractor) understands and agrees that the provisions of 31 U.S.C. §§ 3801, et seq., apply to this certification and disclosure.

\_\_\_\_\_  
Date

\_\_\_\_\_  
Authorized Signature

\_\_\_\_\_  
Title

REQUEST FOR QUOTATION  
ADA Compliant Lowered Floor Mini-Van

---

**BID FORM #10**

**REQUIRED BID DOCUMENTATION CHECKLIST**

Model Year: \_\_\_\_\_ Model: \_\_\_\_\_

**Mandatory Bid Forms – must be submitted with bid:**

- \_\_\_\_\_ Bid Form #1: Locations of Technical Service Representatives and Parts Distribution Centers
- \_\_\_\_\_ Bid Form #2: Certification for Air & Water Pollution
- \_\_\_\_\_ Bid Form #3: Disadvantaged Business Enterprise Vendors/Manufacturers Certification
- \_\_\_\_\_ Bid Form #4: Buy America Certification Rolling Stock
- \_\_\_\_\_ Bid Form #5: Federal Motor Vehicle Safety Standards Certification
- \_\_\_\_\_ Bid Form #6: U.S. Comptroller's Debarment List Certification
- \_\_\_\_\_ Bid Form #7: Certification of Primary Participant Regarding Debarment, Suspension, and Other Responsibility Matters
- \_\_\_\_\_ Bid Form #8: Vendor's Certification of Understanding and Acceptance
- \_\_\_\_\_ Bid Form #9: Certification of Restrictions on Lobbying
- \_\_\_\_\_ Exhibit A Pricing Page

REQUEST FOR QUOTATION  
ADA Compliant Lowered Floor Mini-Van

---

**Documentation – to be submitted with bid:**

**Referenced**

- \_\_\_\_\_ 3.3.1.1 Engine: provide product description, warranty information and product literature.
- \_\_\_\_\_ 3.6.1 Transmission: provide product description, warranty information and product literature.
- \_\_\_\_\_ 3.6.4 Back Up Camera System: provide product description, warranty information and product literature.
- \_\_\_\_\_ 3.11 Tires: provide product description, warranty information and product literature.
- \_\_\_\_\_ 3.14.4 Undercoating and Rustproofing: provide product description, warranty information and literature.
- \_\_\_\_\_ 3.14.7 Ambulatory Passenger Entrance/Exit: provide location, size, door operating details.
- \_\_\_\_\_ 3.19.2 Floor Covering: provide samples of floor covering and colors to be provided.
- \_\_\_\_\_ 3.22 Seating: provide product description, warranty information, product literature and color charts for all of the seating products to be utilized. Proposed floor plan.
- \_\_\_\_\_ 3.2201 Driver's Seat: provide description of product.
- \_\_\_\_\_ 3.27 Wheelchair Securement System: provide product description, warranty information and product literature.
- \_\_\_\_\_ 3.28 Wheelchair Occupant Restraint System: provide product description, warranty information and product literature.
- \_\_\_\_\_ 3.29 Wheelchair Ramp: provide Make, Model #, product description, warranty information and product literature.
- \_\_\_\_\_ 3.35 Training: submit letter of understanding to the terms in this Section.

REQUEST FOR QUOTATION  
**ADA Compliant Lowered Floor Mini-Van**

---

- \_\_\_\_ 3.31.5 Security Camera: provide product description, warranty information and product literature.
  
- \_\_\_\_ 5.9.1 Warranty on complete vehicle.
- \_\_\_\_ 5.9.2 Warranty on Basic Vehicle Structure.
- \_\_\_\_ 5.9.4 Warranty: warranties to be provided on subsystems and components.
  
- \_\_\_\_ 10.2 A. Complete mechanical description of vehicle, its construction and equipment including manufacturer's model name and /or number. Include description of front and rear air conditioning and heat systems.
  
- \_\_\_\_ 10.2 B Proposed interior floor plans, showing detailed dimensions including the location of the wheelchair securement system and stanchions.
  
- \_\_\_\_ 10.2 C. Curb weight (empty weight) and gross vehicle weight rating (GVWR) of vehicle.
  
- \_\_\_\_ 10.2 H. Identification of the conversion location of the van.
  
- \_\_\_\_ 10.2 I. A list of five (5) users names, addresses, emails and telephone numbers who have been provided similar equipment by the Vendor.
  
- \_\_\_\_ No Debt Affidavit
  
- \_\_\_\_ Addendum Acknowledgement

REQUEST FOR QUOTATION  
**ADA Compliant Lowered Floor Mini-Van**

---

List of Suggested Vendors

Bus Service Inc.  
3153 Lamb Avenue  
Columbus, OH 43219

Central States Bus Sales, Inc.  
361 United Court  
Lexington, KY 40509

Midwest Transit Kankakee  
146 Issert Drive  
Kankakee, IL 60901

Mobil 1  
2100 Washington Rd.  
Canonsburg, PA 15317

Rohrer Bus Sales  
1515 State Road  
PO Box 100  
Duncannon, PA 17020

Sonny Merryman Inc.  
PO Box 495  
Rustburg, VA 24588

Transportation Equipment Sales  
P. O. Box 167230  
Oregon, OH 43616

REQUEST FOR QUOTATION  
ADA Compliant Lowered Floor Mini-Van

---

**Appendix A: Frequently Asked Questions from Vendors**

**CRFQ 0810**

**Vendor Questions / Agency Responses:**

**\*Please note that all of these questions may not pertain to the updated specifications of this current bid. If there are additional questions, please provide them and we will respond to the inquiries as soon as possible in order to complete the bidding process.**

REQUEST FOR QUOTATION  
ADA Compliant Lowered Floor Mini-Van

---

**Appendix B: Federal Clauses**

**FEDERAL CLAUSES**  
(where applicable)

**1. No Government Obligation to Third Parties**

- a. MOVTA and CONTRACTOR acknowledge and agree that, notwithstanding any concurrence by the Federal Government in or approval of the solicitation or award of the underlying contract, absent the express written consent by the Federal Government, the Federal Government is not a party to this contract and shall not be subject to any obligations or liabilities to MOVTA, CONTRACTOR, or any other party (whether or not a party to that contract) pertaining to any matter resulting from the underlying contract.
- b. The CONTRACTOR agrees to include the above clause in each subcontract financed in whole or in part with Federal assistance provided by FTA. It is further agreed that the clause shall not be modified, except to identify the SUBCONTRACTOR who will be subject to its provisions.

**2. Program Fraud and False or Fraudulent Statements or Related Acts.**

- a. The CONTRACTOR acknowledges that the provisions of the Program Fraud Civil Remedies Act of 1986, as amended, 31 U.S.C. § 3801 et seq. and U.S. DOT regulations, "Program Fraud Civil Remedies," 49 C.F.R. Part 31, apply to its actions pertaining to this Project. Upon execution of the underlying contract, the CONTRACTOR certifies or affirms the truthfulness and accuracy of any statement it has made, it makes, it may make, or causes to be made, pertaining to the underlying contract or the FTA assisted project for which this contract work is being performed. In addition to other penalties that may be applicable, the CONTRACTOR further acknowledges that if it makes, or causes to be made, a false, fictitious, or fraudulent claim, statement, submission, or certification, the Federal Government reserves the right to impose the penalties of the Program Fraud Civil Remedies Act of 1986 on the CONTRACTOR to the extent the Federal Government deems appropriate.
- b. The CONTRACTOR also acknowledges that if it makes, or causes to be made, a false, fictitious, or fraudulent claim, statement, submission, or certification to the Federal Government under a contract connected with a project that is financed in whole or in part with Federal assistance originally awarded by FTA under the authority of 49 U.S.C. Chapter 53, the Government reserves the right to impose the penalties of 18 U.S.C. § 1001 and 49 U.S.C. § 5323(l) or other applicable federal law on the CONTRACTOR, to the extent the Federal Government deems appropriate.
- c. The CONTRACTOR agrees to include the above two clauses in each subcontract financed in whole or in part with Federal assistance provided by FTA. It is further agreed that the clauses shall not be modified, except to identify the SUBCONTRACTOR who will be subject to the provisions.

**3. Access to Records**

The CONTRACTOR agrees to provide MOVTA, the FTA Administrator, the Comptroller General of the United States or any of their authorized representatives access to any books, documents, papers and records of the CONTRACTOR which are directly pertinent to this contract for the purposes of making audits, examinations, excerpts and transcriptions. The CONTRACTOR agrees to permit any of the foregoing parties to reproduce by any means whatsoever or to copy excerpts and transcriptions as

REQUEST FOR QUOTATION  
ADA Compliant Lowered Floor Mini-Van

---

reasonably needed. In accordance with 2 CFR 200.333, the CONTRACTOR agrees to maintain all books, records, accounts and reports required under this contract for a period of not less than three years after the date of termination or expiration of this contract except in the event of litigation or settlement of claims arising from the performance of this Contract, in which case records shall be maintained until the disposition of all such litigation, appeals, claims or exceptions related thereto.

**4. Federal Changes**

The CONTRACTOR shall at all times comply with all applicable FTA regulations, policies, procedures and directives, including without limitation those listed directly or by reference in the Department of Transportation, Federal Transit Administration, Master Agreement between Purchaser and FTA, as they may be amended or promulgated from time to time during the term of this contract. The CONTRACTOR's failure to comply shall constitute a material breach of this contract.

**5. Civil Rights**

The following requirements apply to the underlying contract:

a. Nondiscrimination - In accordance with Title VI of the Civil Rights Act, as amended, 42 U.S.C. § 2000d, section 303 of the Age Discrimination Act of 1975, as amended, 42 U.S.C. § 6102, section 202 of the Americans with Disabilities Act of 1990, 42 U.S.C. § 12132, and Federal transit law at 49 U.S.C. § 5332, the CONTRACTOR agrees that it will not discriminate against any employee or applicant for employment because of race, color, creed, national origin, sex, age, or disability. In addition, the CONTRACTOR agrees to comply with applicable Federal implementing regulations and other implementing requirements FTA may issue.

b. Equal Employment Opportunity - The following equal employment opportunity requirements apply to the underlying contract:

(i) Race, Color, Creed, National Origin, Sex - In accordance with Title VII of the Civil Rights Act, as amended, 42 U.S.C. § 2000e, and Federal transit laws at 49 U.S.C. § 5332, the CONTRACTOR agrees to comply with all applicable equal employment opportunity requirements of U.S. Department of Labor (U.S. DOL) regulations, "Office of Federal Contract Compliance Programs, Equal Employment Opportunity, Department of Labor," 41 C.F.R. Parts 60 et seq., (which implement Executive Order No. 11246, "Equal Employment Opportunity," as amended by Executive Order No. 11375, "Amending Executive Order 11246 Relating to Equal Employment Opportunity," 42 U.S.C. § 2000e note), and with any applicable Federal statutes, executive orders, regulations, and Federal policies that may in the future affect construction activities undertaken in the course of the Project. The CONTRACTOR agrees to take affirmative action to ensure that applicants are employed, and that employees are treated during employment, without regard to their race, color, creed, national origin, sex, or age. Such action shall include, but not be limited to, the following: employment, upgrading, demotion or transfer, recruitment or recruitment advertising, layoff or termination; rates of pay or other forms of compensation; and selection for training, including apprenticeship. In addition, the CONTRACTOR agrees to comply with any implementing requirements FTA may issue.

(ii) Age - In accordance with section 4 of the Age Discrimination in Employment Act of 1967, as amended, 29 U.S.C. § 623 and Federal transit law at 49 U.S.C. § 5332, the CONTRACTOR agrees to

REQUEST FOR QUOTATION  
ADA Compliant Lowered Floor Mini-Van

---

refrain from discrimination against present and prospective age. In addition, the CONTRACTOR agrees to comply with any implementing requirements FTA may issue.

(iii) Disabilities - In accordance with section 102 of the Americans with Disabilities Act, as amended, 42 U.S.C. § 12112, the CONTRACTOR agrees that it will comply with the requirements of U.S. Equal Employment Opportunity Commission, "Regulations to Implement the Equal Employment Provisions of the Americans with Disabilities Act," 29 C.F.R. Part 1630, pertaining to employment of persons with disabilities. In addition, the CONTRACTOR agrees to comply with any implementing requirements FTA may issue.

c. The CONTRACTOR also agrees to include these requirements in each subcontract financed in whole or in part with Federal assistance provided by FTA, modified only if necessary to identify the affected parties.

**6. Disadvantaged Business Enterprises**

a. It is the policy of the Department of Transportation and MOVTA that Disadvantaged Business Enterprises (DBEs) as defined in 49 C.F.R. part 26 shall have the maximum opportunity to participate in the performance of contracts financed in whole or part with federal funds under this contract.

Consequently, the DBE requirement of 49 C.F.R. applies to this contract.

b. The CONTRACTOR or subcontractor shall not discriminate on the basis of race, color, natural origin, or sex in the performance of this contract. The CONTRACTOR shall carry out applicable requirements of 49 C.F.R. Part 26 in the award and administration of DOT assisted contracts. Failure by the contractor to carry out these requirements is a material breach of this contract, which may result in the termination of this contract or such other remedy as the recipient deems appropriate.

c. DBEs will be encouraged and afforded full opportunity to actively solicit information concerning this project and to submit bids and or proposals.

**7. Incorporation of FTA Terms**

The preceding provisions include, in part, certain Standard Terms and Conditions required by U.S. DOT, whether or not expressly set forth in the preceding contract provisions. All contractual provisions required by U.S. DOT, as set forth in FTA Circular 4220, 2 CFR 200.318, and subsequent revisions are hereby incorporated by reference. Anything to the contrary herein notwithstanding, all FTA-mandated terms shall be deemed to control in the event of a conflict with other provisions contained in this Agreement. The CONTRACTOR shall not perform any act, fail to perform any act, or refuse to comply with any MOVTA request, which would cause MOVTA to be in violation of the FTA terms and conditions.

**8. Energy Conservation**

The CONTRACTOR agrees to comply with mandatory standards and policies relating to energy efficiency which are contained in the state energy conservation plan issued in compliance with the Energy Policy and Conservation Act, 42 U.S.C. §§ 6321 *et seq.*

**9. Termination**

a. Termination for Convenience: MOVTA may terminate this contract, in whole or in part, at any time by written notice to the CONTRACTOR. The CONTRACTOR shall be paid its costs, including contract

REQUEST FOR QUOTATION  
ADA Compliant Lowered Floor Mini-Van

---

closeout costs, and profit on work performed up to the time of termination. The CONTRACTOR shall promptly submit its termination claim to MOVTA to be paid. If the CONTRACTOR has any property in its possession belonging to MOVTA, the CONTRACTOR will account for the same, and dispose of it in the manner MOVTA directs.

b. Termination for Cause: If the CONTRACTOR does not deliver supplies in accordance with the contract delivery schedule, or, if the contract is for services, the CONTRACTOR fails to perform in the manner called for in the contract, or if the CONTRACTOR fails to comply with any other provisions of the contract, MOVTA may terminate this contract for default. Termination shall be effected by serving a notice of termination on the CONTRACTOR setting forth the manner in which the CONTRACTOR is in default. The CONTRACTOR will only be paid the contract price for supplies delivered and accepted, or services performed in accordance with the manner of performance set forth in the contract. If it is later determined by MOVTA that the CONTRACTOR had an excusable reason for not performing, such as a strike, fire, or flood, events which are not the fault of or beyond the control of the CONTRACTOR, MOVTA, after setting up a new delivery of performance schedule, may allow the CONTRACTOR to continue work, or treat the termination as a termination for convenience.

c. Opportunity to Cure: MOVTA in its sole discretion may, in the case of a termination for breach or default, allow the CONTRACTOR ten (10) business days in which to cure the defect. In such case, the notice of termination will state the time period in which cure is permitted and other appropriate conditions. If the CONTRACTOR fails to remedy to MOVTA's satisfaction the breach or default of any of the terms, covenants, or conditions of this Contract within ten (10) days after receipt by the CONTRACTOR of written notice from MOVTA setting forth the nature of said breach or default, MOVTA shall have the right to terminate the Contract without any further obligation to the CONTRACTOR. Any such termination for default shall not in any way operate to preclude MOVTA from also pursuing all available remedies against Contractor and its sureties for said breach or default.

**10. Governmentwide Debarment and Suspension**

By signing and submitting its bid or proposal, the offeror certifies as follows:

The certification in this clause is a material representation of fact relied upon by MOVTA. If it is later determined that the bidder or offeror knowingly rendered an erroneous certification, in addition to remedies available to MOVTA, the Federal Government may pursue available remedies, including but not limited to suspension and/or debarment. The bidder or offeror agrees to comply with the requirements of 49 CFR 29, Subpart C while this offer is valid and throughout the period of any contract that may arise from this offer.

The bidder or offeror further agrees to include a provision requiring such compliance in its lower tier covered transactions.

**11. Notification Related to Fraud, Waste, Abuse, or Other Legal Matters**

If a current or prospective legal matter that may affect the Federal Government emerges, the CONTRACTOR must promptly notify MOVTA so that it can notify the Federal Government. The types of legal matters that require notification include, but are not limited to, a major dispute, breach, default, litigation, or naming the Federal Government as a party to litigation or a legal disagreement in any forum for any reason. Matters that may affect the Federal Government include, but are not limited to, the

REQUEST FOR QUOTATION  
**ADA Compliant Lowered Floor Mini-Van**

---

Federal Government's interests in the Award, the accompanying Underlying Agreement, and any Amendments thereto, or the Federal Government's administration or enforcement of federal laws, regulations, and requirements.

The CONTRACTOR agrees to include a similar notification requirement in subcontracts exceeding \$25,000 financed in whole or in part with federal assistance provided by FTA and must require each subcontractor to include an equivalent provision in its federally assisted subcontracts exceeding \$25,000.

**12. Lobbying Restrictions**

The CONTRACTOR agrees to:

- a. Refrain from using Federal assistance funds to support lobbying,
- b. Comply and assure the compliance of each SUBCONTRACTOR at any tier, with U.S. DOT regulations, "New Restrictions on Lobbying," 49 C.F.R. Part 20, modified as necessary by 31 U.S.C. § 1352.
- c. Comply with Federal statutory provisions to the extent applicable prohibiting the use of Federal assistance funds for activities designed to influence Congress or a State legislature on legislation or appropriations, except through proper, official channels.

**13. Buy America**

The CONTRACTOR agrees to comply with 49 U.S.C. 5323(j), 49 C.F.R. part 661, Pub. L. No. 117-58, and Pub. L. No. 117-58, §§ 70901-52 which provide that Federal funds may not be obligated unless all steel, iron, and manufactured products or construction materials used in FTA funded projects are produced in the United States unless a waiver has been granted by FTA or the product is subject to a general waiver.. General waivers are listed in 49 C.F.R. §661.7, and includes microcomputer equipment, software, and small purchases (currently less than \$150,000) made with capital, operating, or planning funds. Separate requirements for rolling stock are set out at 49 U.S.C. 5323(j)(2)(C) and 49 C.F.R. 661.11. Rolling stock must be assembled in the United States and have a 70 percent domestic content. A bidder or offeror must submit to the FTA recipient the appropriate Buy America certification with all bids or offers on FTA-funded contracts, except those subject to a general waiver. Bids or offers that are not accompanied by a completed Buy America certification must be rejected as nonresponsive. This requirement does not apply to lower-tier subcontractors.

**14. Clean Air**

- a. The CONTRACTOR agrees to comply with all applicable standards, orders or regulations issued pursuant to the Clean Air Act, as amended, 42 U.S.C. §§ 7401 through 7671q. The Contractor agrees to report each violation to the Purchaser and understands and agrees that the Purchaser will, in turn, report each violation as required to assure notification to FTA and the appropriate EPA Regional Office.
- b. The CONTRACTOR also agrees to include these requirements in each subcontract exceeding \$150,000 financed in whole or in part with Federal assistance provided by FTA.

**15. Clean Water**

- a. The CONTRACTOR agrees to comply with all applicable standards, orders or regulations issued pursuant to the Clean Water Act, as amended, 33 U.S.C. §§1251 through 1377. The Contractor agrees to

REQUEST FOR QUOTATION  
ADA Compliant Lowered Floor Mini-Van

---

report each violation to the Purchaser and understands and agrees that the Purchaser will, in turn, report each violation as required to assure notification to FTA and the appropriate EPA Regional Office.

b. The CONTRACTOR also agrees to include these requirements in each subcontract exceeding \$150,000 financed in whole or in part with Federal assistance provided by FTA.

**16. Breaches and Disputes**

- a. Disputes - Disputes arising in the performance of this Contract which are not resolved by agreement of the parties shall be decided in writing by the authorized representative of MOVTA. This decision shall be final and conclusive unless within ten (10) days from the date of receipt of its copy, the CONTRACTOR mails or otherwise furnishes a written appeal to MOVTA. In connection with any such appeal, the CONTRACTOR shall be afforded an opportunity to be heard and to offer evidence in support of its position. The decision of MOVTA shall be binding upon the CONTRACTOR and the CONTRACTOR shall abide by the decision.
- b. Performance During Dispute - Unless otherwise directed by MOVTA, CONTRACTOR shall continue performance under this Contract while matters in dispute are being resolved.
- c. Claims for Damages - Should either party to the Contract suffer injury or damage to person or property because of any act or omission of the party or of any of his employees, agents or others for whose acts he is legally liable, a claim for damages therefore shall be made in writing to such other party within a reasonable time after the first observance of such injury or damage.
- d. Remedies - Unless this contract provides otherwise, all claims, counterclaims, disputes and other matters in question between MOVTA and the CONTRACTOR arising out of or relating to this agreement or its breach will be decided by arbitration if the parties mutually agree, or in a court of competent jurisdiction within the State of West Virginia.
- e. Rights and Remedies - The duties and obligations imposed by the Contract Documents and the rights and remedies available thereunder shall be in addition to and not a limitation of any duties, obligations, rights and remedies otherwise imposed or available by law. No action or failure to act by MOVTA, Architect or CONTRACTOR shall constitute a waiver of any right or duty afforded any of them under the Contract, nor shall any such action or failure to act constitute an approval of or acquiescence in any breach thereunder, except as may be specifically agreed in writing.

**17. Cargo Preference - Use of United States- Flag Vessels**

To the extent applicable, the contractor agrees to comply with 46 U.S.C. §55305 and 46 C.F.R. Part 381 which includes, but is not limited to:

- a. to use privately owned United States-Flag commercial vessels to ship at least 50 percent of the gross tonnage (computed separately for dry bulk carriers, dry cargo liners, and tankers) involved, whenever shipping any equipment, material, or commodities pursuant to the underlying contract to the extent such vessels are available at fair and reasonable rates for United States-Flag commercial vessels;
- b. to furnish within 20 working days following the date of loading for shipments originating within the United States or within 30 working days following the date of loading for shipments originating outside the United States, a legible copy of a rated, "on-board" commercial ocean bill-of-lading in English for each shipment of cargo described in the preceding paragraph to the Division of National Cargo, Office of

REQUEST FOR QUOTATION  
ADA Compliant Lowered Floor Mini-Van

---

Market Development, Maritime Administration, Washington, DC 20590 and to the FTA recipient (through the contractor in the case of a subcontractor's bill-of-lading.)

c. to include these requirements in all subcontracts issued pursuant to this contract when the subcontract may involve the transport of equipment, material, or commodities by ocean vessel.

**18. Davis-Bacon and Copeland Anti-Kickback Acts**

The CONTRACTOR agrees to comply and assure compliance of each third party contractor and each subcontractor at any tier of the project with the following Federal laws and regulations providing protections for their employees:

a. **Minimum wages** - (i) All laborers and mechanics employed or working upon the site of the work (or under the United States Housing Act of 1937 or under the Housing Act of 1949 in the construction or development of the project), will be paid unconditionally and not less often than once a week, and without subsequent deduction or rebate on any account (except such payroll deductions as are permitted by regulations issued by the Secretary of Labor under the Copeland Act (29 C.F.R. part 3)), the full amount of wages and bona fide fringe benefits (or cash equivalents thereof) due at time of payment computed at rates not less than those contained in the wage determination of the Secretary of Labor which is attached hereto and made a part hereof, regardless of any contractual relationship which may be alleged to exist between the contractor and such laborers and mechanics.

Contributions made or costs reasonably anticipated for bona fide fringe benefits under section 1(b)(2) of the Davis-Bacon Act on behalf of laborers or mechanics are considered wages paid to such laborers or mechanics, subject to the provisions of paragraph (1)(iv) of this section; also, regular contributions made or costs incurred for more than a weekly period (but not less often than quarterly) under plans, funds, or programs which cover the particular weekly period, are deemed to be constructively made or incurred during such weekly period. Such laborers and mechanics shall be paid the appropriate wage rate and fringe benefits on the wage determination for the classification of work actually performed, without regard to skill, except as provided in 29 C.F.R. Part 5.5(a)(4). Laborers or mechanics performing work in more than one classification may be compensated at the rate specified for each classification for the time actually worked therein: Provided, that the employer's payroll records accurately set forth the time spent in each classification in which work is performed. The wage determination (including any additional classifications and wage rates conformed under paragraph (1)(ii) of this section) and the Davis-Bacon poster (WH-1321) shall be posted at all times by the contractor and its subcontractors at the site of the work in a prominent and accessible place where it can be easily seen by the workers.

(ii)(A) The contracting officer shall require that any class of laborers or mechanics, including helpers, which is not listed in the wage determination, and which is to be employed under the contract shall be classified in conformance with the wage determination. The contracting officer shall approve an additional classification and wage rate and fringe benefits therefore only when the following criteria have been met:

- (1) Except with respect to helpers as defined as 29 C.F.R. 5.2(n)(4), the work to be performed by the classification requested is not performed by a classification in the wage determination; and
- (2) The classification is utilized in the area by the construction industry; and
- (3) The proposed wage rate, including any bona fide fringe benefits, bears a reasonable relationship to the wage rates contained in the wage determination; and

REQUEST FOR QUOTATION  
ADA Compliant Lowered Floor Mini-Van

---

(4) With respect to helpers as defined in 29 C.F.R. 5.2(n)(4), such a classification prevails in the area in which the work is performed.

(B) If the contractor and the laborers and mechanics to be employed in the classification (if known), or their representatives, and the contracting officer agree on the classification and wage rate (including the amount designated for fringe benefits where appropriate), a report of the action taken shall be sent by the contracting officer to the Administrator of the Wage and Hour Division, Employment Standards Administration, U.S. Department of Labor, Washington, DC 20210. The Administrator, or an authorized representative, will approve, modify, or disapprove every additional classification action within 30 days of receipt and so advise the contracting officer or will notify the contracting officer within the 30-day period that additional time is necessary.

(C) In the event the contractor, the laborers or mechanics to be employed in the classification or their representatives, and the contracting officer do not agree on the proposed classification and wage rate (including the amount designated for fringe benefits, where appropriate), the contracting officer shall refer the questions, including the views of all interested parties and the recommendation of the contracting officer, to the Administrator for determination. The Administrator, or an authorized representative, will issue a determination within 30 days of receipt and so advise the contracting officer or will notify the contracting officer within the 30-day period that additional time is necessary.

(D) The wage rate (including fringe benefits where appropriate) determined pursuant to paragraphs (a)(1)(ii) (B) or (C) of this section, shall be paid to all workers performing work in the classification under this contract from the first day on which work is performed in the classification.

(iii) Whenever the minimum wage rate prescribed in the contract for a class of laborers or mechanics includes a fringe benefit which is not expressed as an hourly rate, the contractor shall either pay the benefit as stated in the wage determination or shall pay another bona fide fringe benefit or an hourly cash equivalent thereof.

(iv) If the contractor does not make payments to a trustee or other third person, the contractor may consider as part of the wages of any laborer or mechanic the amount of any costs reasonably anticipated in providing bona fide fringe benefits under a plan or program, provided, that the Secretary of Labor has found, upon the written request of the contractor, that the applicable standards of the Davis-Bacon Act have been met. The Secretary of Labor may require the contractor to set aside in a separate account asset for the meeting of obligations under the plan or program.

(v)(A) The contracting officer shall require that any class of laborers or mechanics which is not listed in the wage determination, and which is to be employed under the contract shall be classified in conformance with the wage determination. The contracting officer shall approve an additional classification and wage rate and fringe benefits therefore only when the following criteria have been met:

(1) The work to be performed by the classification requested is not performed by a classification in the wage determination; and

(2) The classification is utilized in the area by the construction industry; and

(3) The proposed wage rate, including any bona fide fringe benefits, bears a reasonable relationship to the wage rates contained in the wage determination.

(B) If the contractor and the laborers and mechanics to be employed in the classification (if known), or their representatives, and the contracting officer agree on the classification and wage rate (including the amount designated for fringe benefits where appropriate), a report of the action taken shall be sent by the

REQUEST FOR QUOTATION  
ADA Compliant Lowered Floor Mini-Van

---

contracting officer to the Administrator of the Wage and Hour Division, Employment Standards Administration, Washington, DC 20210. The Administrator, or an authorized representative, will approve, modify, or disapprove every additional classification action within 30 days of receipt and so advise the contracting officer or will notify the contracting officer within the 30-day period that additional time is necessary.

(C) In the event the contractor, the laborers or mechanics to be employed in the classification or their representatives, and the contracting officer do not agree on the proposed classification and wage rate (including the amount designated for fringe benefits, where appropriate), the contracting officer shall refer the questions, including the views of all interested parties and the recommendation of the contracting officer, to the Administrator for determination. The Administrator, or an authorized representative, will issue a determination within 30 days of receipt and so advise the contracting officer or will notify the contracting officer within the 30-day period that additional time is necessary.

(D) The wage rate (including fringe benefits where appropriate) determined pursuant to paragraphs (a)(1)(v) (B) or (C) of this section, shall be paid to all workers performing work in the classification under this contract from the first day on which work is performed in the classification.

**b. Withholding** - MOVTA shall upon its own action or upon written request of an authorized representative of the Department of Labor withhold or cause to be withheld from the contractor under this contract or any other Federal contract with the same prime contractor, or any other federally-assisted contract subject to Davis-Bacon prevailing wage requirements, which is held by the same prime contractor, so much of the accrued payments or advances as may be considered necessary to pay laborers and mechanics, including apprentices, trainees, and helpers, employed by the contractor or any subcontractor the full amount of wages required by the contract. In the event of failure to pay any laborer or mechanic, including any apprentice, trainee, or helper, employed or working on the site of the work (or under the United States Housing Act of 1937 or under the Housing Act of 1949 in the construction or development of the project), all or part of the wages required by the contract, MOVTA may, after written notice to the contractor, sponsor, applicant, or owner, take such action as may be necessary to cause the suspension of any further payment, advance, or guarantee of funds until such violations have ceased.

**c. Payrolls and basic records** - (i) Payrolls and basic records relating thereto shall be maintained by the contractor during the course of the work and preserved for a period of three years thereafter for all laborers and mechanics working at the site of the work (or under the United States Housing Act of 1937, or under the Housing Act of 1949, in the construction or development of the project). Such records shall contain the name, address, and social security number of each such worker, his or her correct classification, hourly rates of wages paid (including rates of contributions or costs anticipated for bona fide fringe benefits or cash equivalents thereof of the types described in section 1(b)(2)(B) of the Davis-Bacon Act, daily and weekly number of hours worked, deductions made and actual wages paid. Whenever the Secretary of Labor has found under 29 C.F.R. 5.5(a)(1)(iv) that the wages of any laborer or mechanic include the amount of any costs reasonably anticipated in providing benefits under a plan or program described in section 1(b)(2)(B) of the Davis-Bacon Act, the contractor shall maintain records which show that the commitment to provide such benefits is enforceable, that the plan or program is financially responsible, and that the plan or program has been communicated in writing to the laborers or

REQUEST FOR QUOTATION  
ADA Compliant Lowered Floor Mini-Van

---

mechanics affected, and records which show the costs anticipated or the actual cost incurred in providing such benefits. Contractors employing apprentices or trainees under approved programs shall maintain written evidence of the registration of apprenticeship programs and certification of trainee programs, the registration of the apprentices and trainees, and the ratios and wage rates prescribed in the applicable programs.

(ii)(A) The contractor shall submit weekly for each week in which any contract work is performed a copy of all payrolls to MOVTA for transmission to the Federal Transit Administration. The payrolls submitted shall set out accurately and completely all of the information required to be maintained under section 5.5(a)(3)(i) of Regulations, 29 C.F.R. part 5. This information may be submitted in any form desired. Optional Form WH-347 is available for this purpose and may be purchased from the Superintendent of Documents (Federal Stock Number 029-005-00014-1), U.S. Government Printing Office, Washington, DC 20402. The prime contractor is responsible for the submission of copies of payrolls by all subcontractors.

(B) Each payroll submitted shall be accompanied by a "Statement of Compliance," signed by the contractor or subcontractor or his or her agent who pays or supervises the payment of the persons employed under the contract and shall certify the following:

- (1) That the payroll for the payroll period contains the information required to be maintained under section 5.5(a)(3)(i) of Regulations, 29 C.F.R. part 5 and that such information is correct and complete;
- (2) That each laborer or mechanic (including each helper, apprentice, and trainee) employed on the contract during the payroll period has been paid the full weekly wages earned, without rebate, either directly or indirectly, and that no deductions have been made either directly or indirectly from the full wages earned, other than permissible deductions as set forth in Regulations, 29 C.F.R. Part 3;
- (3) That each laborer or mechanic has been paid no less than the applicable wage rates and fringe benefits or cash equivalents for the classification of work performed, as specified in the applicable wage determination incorporated into the contract.

(C) The weekly submission of a properly executed certification set forth on the reverse side of Optional Form WH-347 shall satisfy the requirement for submission of the "Statement of Compliance" required by paragraph (a)(3)(ii)(B) of this section.

(D) The falsification of any of the above certifications may subject the contractor or subcontractor to civil or criminal prosecution under section 1001 of title 18 and section 231 of Title 31 of the United States Code.

(iii) The contractor or subcontractor shall make the records required under paragraph (a)(3)(i) of this section available for inspection, copying, or transcription by authorized representatives of the Federal Transit Administration or the Department of Labor, and shall permit such representatives to interview employees during working hours on the job. If the contractor or subcontractor fails to submit the required records or to make them available, the Federal agency may, after written notice to the contractor, sponsor, applicant, or owner, take such action as may be necessary to cause the suspension of any further payment, advance, or guarantee of funds. Furthermore, failure to submit the required records upon request or to make such records available may be grounds for debarment action pursuant to 29 C.F.R. 5.12.

d. **Apprentices and trainees** - (i) Apprentices - Apprentices will be permitted to work at less than the predetermined rate for the work they performed when they are employed pursuant to and individually

REQUEST FOR QUOTATION  
ADA Compliant Lowered Floor Mini-Van

---

registered in a bona fide apprenticeship program registered with the U.S. Department of Labor, Employment and Training Administration, Bureau of Apprenticeship and Training, or with a State Apprenticeship Agency recognized by the Bureau, or if a person is employed in his or her first 90 days of probationary employment as an apprentice in such an apprenticeship program, who is not individually registered in the program, but who has been certified by the Bureau of Apprenticeship and Training or a State Apprenticeship Agency (where appropriate) to be eligible for probationary employment as an apprentice. The allowable ratio of apprentices to journeymen on the job site in any craft classification shall not be greater than the ratio permitted to the contractor as to the entire work force under the registered program. Any worker listed on a payroll at an apprentice wage rate, who is not registered or otherwise employed as stated above, shall be paid not less than the applicable wage rate on the wage determination for the classification of work performed. In addition, any apprentice performing work on the job site in excess of the ratio permitted under the registered program shall be paid not less than the applicable wage rate on the wage determination for the work actually performed. Where a contractor is performing construction on a project in a locality other than that in which its program is registered, the ratios and wage rates (expressed in percentages of the journeyman's hourly rate) specified in the contractor's or subcontractor's registered program shall be observed. Every apprentice must be paid at not less than the rate specified in the registered program for the apprentice's level of progress, expressed as a percentage of the journeymen hourly rate specified in the applicable wage determination. Apprentices shall be paid fringe benefits in accordance with the provisions of the apprenticeship program. If the apprenticeship program does not specify fringe benefits, apprentices must be paid the full amount of fringe benefits listed on the wage determination for the applicable classification. If the Administrator of the Wage and Hour Division of the U.S. Department of Labor determines that a different practice prevails for the applicable apprentice classification, fringes shall be paid in accordance with that determination. In the event the Bureau of Apprenticeship and Training, or a State Apprenticeship Agency recognized by the Bureau, withdraws approval of an apprenticeship program, the contractor will no longer be permitted to utilize apprentices at less than the applicable predetermined rate for the work performed until an acceptable program is approved.

(ii) Trainees - Except as provided in 29 C.F.R. 5.16, trainees will not be permitted to work at less than the predetermined rate for the work performed unless they are employed pursuant to and individually registered in a program which has received prior approval, evidenced by formal certification by the U.S. Department of Labor, Employment and Training Administration. The ratio of trainees to journeymen on the job site shall not be greater than permitted under the plan approved by the Employment and Training Administration. Every trainee must be paid at not less than the rate specified in the approved program for the trainee's level of progress, expressed as a percentage of the journeyman's hourly rate specified in the applicable wage determination. Trainees shall be paid fringe benefits in accordance with the provisions of the trainee program. If the trainee program does not mention fringe benefits, trainees shall be paid the full amount of fringe benefits listed on the wage determination unless the Administrator of the Wage and Hour Division determines that there is an apprenticeship program associated with the corresponding journeyman wage rate on the wage determination which provides for less than full fringe benefits for apprentices. Any employee listed on the payroll at a trainee rate that is not registered and participating in a training plan approved by the Employment and Training Administration shall be paid not less than the applicable wage rate on the wage determination for the classification of work actually performed. In

REQUEST FOR QUOTATION  
ADA Compliant Lowered Floor Mini-Van

---

addition, any trainee performing work on the job site in excess of the ratio permitted under the registered program shall be paid not less than the applicable wage rate on the wage determination for the work actually performed. In the event the Employment and Training Administration withdraws approval of a training program, the contractor will no longer be permitted to utilize trainees at less than the applicable predetermined rate for the work performed until an acceptable program is approved.

(iii) Equal employment opportunity - The utilization of apprentices, trainees and journeymen under this part shall be in conformity with the equal employment opportunity requirements of Executive Order 11246, as amended, and 29 C.F.R. Part 30.

e. **Compliance with Copeland Act requirements** - The contractor shall comply with the requirements of 29 C.F.R. Part 3, which are incorporated by reference in this contract.

f. **Subcontracts** - The contractor or subcontractor shall insert in any subcontracts the clauses contained in 29 C.F.R. 5.5(a)(1) through (10) and such other clauses as the Federal Transit Administration may by appropriate instructions require, and also a clause requiring the subcontractors to include these clauses in any lower tier subcontracts. The prime contractor shall be responsible for the compliance by any subcontractor or lower tier subcontractor with all the contract clauses in 29 C.F.R. 5.5.

g. **Contract termination: debarment** - A breach of the contract clauses in 29 C.F.R. 5.5 may be grounds for termination of the contract, and for debarment as a contractor and a subcontractor as provided in 29 C.F.R. 5.12.

h. **Compliance with Davis-Bacon and Related Act requirements** - All rulings and interpretations of the Davis-Bacon and Related Acts contained in 29 C.F.R. parts 1, 3, and 5 are herein incorporated by reference in this contract.

i. **Disputes concerning labor standards** - Disputes arising out of the labor standards provisions of this contract shall not be subject to the general disputes clause of this contract. Such disputes shall be resolved in accordance with the procedures of the Department of Labor set forth in 29 C.F.R. Parts 5, 6, and 7. Disputes within the meaning of this clause include disputes between the contractor (or any of its subcontractors) and the contracting agency, the U.S. Department of Labor, or the employees or their representatives.

j. **Certification of eligibility** - (i) By entering into this contract, the contractor certifies that neither it (nor he or she) nor any person or firm who has an interest in the contractor's firm is a person or firm ineligible to be awarded Government contracts by virtue of section 3(a) of the Davis-Bacon Act or 29 C.F.R. 5.12(a)(1).

(ii) No part of this contract shall be subcontracted to any person or firm ineligible for award of a Government contract by virtue of section 3(a) of the Davis-Bacon Act or 29 C.F.R. 5.12(a)(1).

(iii) The penalty for making false statements is prescribed in the U.S. Criminal Code, 18 U.S.C. 1001.

**19. Contract Work Hours and Safety Standards Act**

The CONTRACTOR agrees to comply with and assure compliance by subcontractors and other project participants for construction employees with the Contract Work Hours and Safety Standards Act, as amended, 40 U.S.C. §§ 3701 et seq., specifically the wage and hour requirements of section 102 of that Act at 40 U.S.C. § 3702, and implementing U.S. DOL regulations, "Labor Standards Provisions Applicable to Contracts Governing Federally Financed and Assisted Construction (also Labor Standards Provisions Applicable to Nonconstruction Contracts Subject to the Contract Work Hours and Safety Standards Act)," 29 C.F.R. Part 5; and the safety requirements of section 107 of that Act at 40 U.S.C. §

REQUEST FOR QUOTATION  
ADA Compliant Lowered Floor Mini-Van

---

3704, and implementing U.S. DOL regulations, "Safety and Health Regulations for Construction," 29 C.F.R. Part 1926.

The CONTRACTOR further agrees to comply with and assure compliance by other project participants for nonconstruction employees with the Contract Work Hours and Safety Standards Act, as amended, 40 U.S.C. §§ 3701 et seq., in particular with the wage and hour requirements of section 102 of that Act at 40 U.S.C. § 3702, and with implementing U.S. DOL regulations, "Labor Standards Provisions Applicable to Contracts Governing Federally Financed and Assisted Construction (also Labor Standards Provisions Applicable to Nonconstruction Contracts Subject to the Contract Work Hours and safety Standards Act)," 29 C.F.R. Part 5.

**20. Bonding Requirements**

**Bid Bond Requirements**

Bid Bond will be five (5) percent of the bid price and must be issued by a fully qualified surety company acceptable to MOVTA and listed as a company currently authorized under 31 C.F.R., Part 223 as possessing a Certificate of Authority as described thereunder.

In submitting this Bid, it is understood and agreed by bidder that the right is reserved by MOVTA to reject any and all bids, or part of any bid, and it is agreed that the Bid may not be withdrawn for a period of [ninety (90)] days subsequent to the opening of bids, without the written consent of MOVTA.

It is also understood and agreed that if the undersigned bidder should withdraw any part or all of his bid within [ninety (90)] days after the bid opening without the written consent of MOVTA, shall refuse or be unable to enter into this Contract, as provided above, or refuse or be unable to furnish adequate and acceptable Performance Bonds and Labor and Material Payments Bonds, or refuse or be unable to furnish adequate and acceptable insurance, he shall forfeit his bid security to the extent of MOVTA damages occasioned by such withdrawal, or refusal, or inability to enter into an agreement, or provide adequate security therefor.

It is further understood and agreed that to the extent the defaulting bidder's Bid Bond, Certified Check, Cashier's Check, Treasurer's Check, and/or Official Bank Check (excluding any income generated thereby which has been retained by MOVTA as provided in [Item x "Bid Security" of the Instructions to Bidders]) shall prove inadequate to fully recompense MOVTA for the damages occasioned by default, then the undersigned bidder agrees to indemnify MOVTA and pay over to MOVTA the difference between the bid security and MOVTA's total damages, so as to make MOVTA whole. The undersigned understands that any material alteration of any of the above or any of the material contained on this form, other than that requested, will render the bid unresponsive.

**Performance Bonds**

1. The penal amount of performance bonds shall be 100 percent of the original contract price, unless MOVTA determines that a lesser amount would be adequate for the protection of MOVTA.
2. MOVTA may require additional performance bond protection when a contract price is increased. The increase in protection shall generally equal 100 percent of the increase in contract price. MOVTA may secure additional protection by directing the Contractor to increase the penal amount of the existing bond or to obtain an additional bond.

REQUEST FOR QUOTATION  
ADA Compliant Lowered Floor Mini-Van

---

**Payment Bonds**

A payment bond of 100 percent of the original contract price unless MOVTA determines that a lesser amount would be adequate for the protection of MOVTA.

**21. Veterans Preference**

As provided in 49 U.S.C. § 5325(k), to the extent practicable, the contractor agrees and assures that it and its subcontractors will give a hiring preference to veterans, as defined in 5 U.S.C. § 2108, who have the skills and abilities required to perform construction work required under the contract.

This does not require the contractor to give a preference to any veteran over any equally qualified applicant who is a member of any racial or ethnic minority, female, an individual with a disability, or a former employee.

**22. Seismic Safety**

The CONTRACTOR agrees that they will comply with 42 U.S.C. §7701 et seq. in accordance with Executive Order No. 12699 as well as with the standards for Seismic Safety required in Department of Transportation Seismic Safety Regulations 49 C.F.R. Part 41 and will certify to compliance to the extent required by the regulation. The CONTRACTOR also agrees to ensure that all work performed under this contract including work performed by a subcontractor is in compliance with the standards required by the Seismic Safety Regulations and the certification of compliance issued on the project.

**23. Recycled Products**

To the extent applicable, the CONTRACTOR agrees to comply with U.S. EPA regulations, "Comprehensive Procurement Guidelines for Products Containing Recovered Materials," 40 C.F.R. Part 247, implementing section 6002 of the Resource Conservation and Recovery Act, as amended, 42 U.S.C. § 6962, and otherwise provide a competitive preference for products and services that conserve natural resources and protect the environment and are energy efficient.

**24. Accessibility**

The CONTRACTOR agrees to comply with 49 U.S.C. §5301(d), which states the Federal policy that elderly individuals and individuals with disabilities have the same right as other individuals to use public transportation services and facilities, and that special efforts shall be made in planning and designing those services and facilities to implement transportation accessibility rights for elderly individuals and individuals with disabilities. The CONTRACTOR also agrees to comply with all applicable provisions of Section 504 of the Rehabilitation Act, as amended, 29 U.S.C. §794, which prohibits discrimination on the basis of disability in the administration of programs or activities receiving Federal financial assistance; with the Americans with Disabilities Act of 1990 (ADA), as amended, 42 U.S.C. §12101 et seq., which requires that accessible facilities and services be made available to individuals with disabilities; with the Architectural Barriers Act of 1968, a amended, 42 U.S.C. §4151 et seq., which requires that buildings and public accommodations be accessible to individuals with disabilities; and with other laws and amendments thereto pertaining to access for individuals with disabilities that may be applicable. In

REQUEST FOR QUOTATION  
ADA Compliant Lowered Floor Mini-Van

---

addition, the CONTRACTOR agrees to comply with applicable implementing Federal regulations and any later amendments thereto, and agrees to follow applicable Federal implementing directives, except to the extent the FTA approves otherwise in writing.

**25. Equal Employment Opportunity**

During the performance of this contract, the contractor agrees as follows:

(1) The contractor will not discriminate against any employee or applicant for employment because of race, color, religion, sex, sexual orientation, gender identity, or national origin. The contractor will take affirmative action to ensure that applicants are employed, and that employees are treated during employment without regard to their race, color, religion, sex, sexual orientation, gender identity, or national origin. Such action shall include, but not be limited to the following:

Employment, upgrading, demotion, or transfer; recruitment or recruitment advertising; layoff or termination; rates of pay or other forms of compensation; and selection for training, including apprenticeship. The contractor agrees to post in conspicuous places, available to employees and applicants for employment, notices to be provided setting forth the provisions of this nondiscrimination clause.

(2) The contractor will, in all solicitations or advertisements for employees placed by or on behalf of the contractor, state that all qualified applicants will receive consideration for employment without regard to race, color, religion, sex, sexual orientation, gender identity, or national origin.

(3) The contractor will not discharge or in any other manner discriminate against any employee or applicant for employment because such employee or applicant has inquired about, discussed, or disclosed the compensation of the employee or applicant or another employee or applicant. This provision shall not apply to instances in which an employee who has access to the compensation information of other employees or applicants as a part of such employee's essential job functions discloses the compensation of such other employees or applicants to individuals who do not otherwise have access to such information, unless such disclosure is in response to a formal complaint or charge, in furtherance of an investigation, proceeding, hearing, or action, including an investigation conducted by the employer, or is consistent with the contractor's legal duty to furnish information.

(4) The contractor will send to each labor union or representative of workers with which he has a collective bargaining agreement or other contract or understanding, a notice to be provided advising the said labor union or workers' representatives of the contractor's commitments under this section, and shall post copies of the notice in conspicuous places available to employees and applicants for employment.

(5) The contractor will comply with all provisions of Executive Order 11246 of September 24, 1965, and of the rules, regulations, and relevant orders of the Secretary of Labor.

(6) The contractor will furnish all information and reports required by Executive Order 11246 of September 24, 1965, and by rules, regulations, and orders of the Secretary of Labor, or pursuant thereto, and will permit access to his books, records, and accounts by the administering agency and the Secretary of Labor for purposes of investigation to ascertain compliance with such rules, regulations, and orders.

(7) In the event of the contractor's noncompliance with the nondiscrimination clauses of this contract or with any of the said rules, regulations, or orders, this contract may be canceled, terminated, or suspended in whole or in part and the contractor may be declared ineligible for further Government contracts or federally assisted construction contracts in accordance with procedures authorized in Executive Order

REQUEST FOR QUOTATION  
**ADA Compliant Lowered Floor Mini-Van**

---

11246 of September 24, 1965, and such other sanctions may be imposed and remedies invoked as provided in Executive Order 11246 of September 24, 1965, or by rule, regulation, or order of the Secretary of Labor, or as otherwise provided by law.

(8) The contractor will include the portion of the sentence immediately preceding paragraph (1) and the provisions of paragraphs (1) through (8) in every subcontract or purchase order unless exempted by rules, regulations, or orders of the Secretary of Labor issued pursuant to section 204 of Executive Order 11246 of September 24, 1965, so that such provisions will be binding upon each subcontractor or vendor. The contractor will take such action with respect to any subcontract or purchase order as the administering agency may direct as a means of enforcing such provisions, including sanctions for noncompliance: Provided, however, that in the event a contractor becomes involved in, or is threatened with, litigation with a subcontractor or vendor as a result of such direction by the administering agency, the contractor may request the United States to enter into such litigation to protect the interests of the United States. The applicant further agrees that it will be bound by the above equal opportunity clause with respect to its own employment practices when it participates in federally assisted construction work: Provided, That if the applicant so participating is a State or local government, the above equal opportunity clause is not applicable to any agency, instrumentality or subdivision of such government which does not participate in work on or under the contract.

The applicant agrees that it will assist and cooperate actively with the administering agency and the Secretary of Labor in obtaining the compliance of contractors and subcontractors with the equal opportunity clause and the rules, regulations, and relevant orders of the Secretary of Labor, that it will furnish the administering agency and the Secretary of Labor such information as they may require for the supervision of such compliance, and that it will otherwise assist the administering agency in the discharge of the agency's primary responsibility for securing compliance.

The applicant further agrees that it will refrain from entering into any contract or contract modification subject to Executive Order 11246 of September 24, 1965, with a contractor debarred from, or who has not demonstrated eligibility for, Government contracts and federally assisted construction contracts pursuant to the Executive Order and will carry out such sanctions and penalties for violation of the equal opportunity clause as may be imposed upon contractors and subcontractors by the administering agency or the Secretary of Labor pursuant to Part II, Subpart D of the Executive Order. In addition, the applicant agrees that if it fails or refuses to comply with these undertakings, the administering agency may take any or all of the following actions: Cancel, terminate, or suspend in whole or in part this grant (contract, loan, insurance, guarantee); refrain from extending any further assistance to the applicant under the program with respect to which the failure or refund occurred until satisfactory assurance of future compliance has been received from such applicant; and refer the case to the Department of Justice for appropriate legal proceedings.

Each nonexempt prime contractor or subcontractor shall include the equal opportunity clause in each of its nonexempt subcontracts.

**26. Seat Belt Use**

The Contractor agrees to adopt and promote on-the-job seat belt use policies and programs for its employees and other personnel that operate company-owned vehicles, company-rented vehicles, or personally operated vehicles.

REQUEST FOR QUOTATION  
**ADA Compliant Lowered Floor Mini-Van**

---

**27. Distracted Driving**

The Contractor agrees to adopt and enforce workplace safety policies to decrease crashes caused by distracted drivers, including policies to ban text messaging while using an electronic device supplied by an employer, and driving a vehicle the driver owns or rents, a vehicle Recipient owns, leases, or rents, or a privately-owned vehicle when on official business in connection with the Award, or when performing any work for or on behalf of the project.

The Contractor agrees to conduct workplace safety initiatives in a manner commensurate with its size, such as establishing new rules and programs to prohibit text messaging while driving, re-evaluating the existing programs to prohibit text messaging while driving, and providing education, awareness, and other outreach to employees about the safety risks associated with texting while driving.

The Contractor agrees to include the preceding Special Provision in its subcontractor agreements.

**ADDENDUM ACKNOWLEDGEMENT FORM**  
**SOLICITATION NO.: CRFQ DMT240000006**

**Instructions:** Please acknowledge receipt of all addenda issued with this solicitation by completing this addendum acknowledgment form. Check the box next to each addendum received and sign below. Failure to acknowledge addenda may result in bid disqualification.

**Acknowledgment:** I hereby acknowledge receipt of the following addenda and have made the necessary revisions to my proposal, plans and/or specification, etc.

**Addendum Numbers Received:**

(Check the box next to each addendum received)

- |  |  |
|--|--|
| <input type="checkbox"/> Addendum No. 1            | <input type="checkbox"/> Addendum No. 6  |
| <input checked="" type="checkbox"/> Addendum No. 2 | <input type="checkbox"/> Addendum No. 7  |
| <input type="checkbox"/> Addendum No. 3            | <input type="checkbox"/> Addendum No. 8  |
| <input type="checkbox"/> Addendum No. 4            | <input type="checkbox"/> Addendum No. 9  |
| <input type="checkbox"/> Addendum No. 5            | <input type="checkbox"/> Addendum No. 10 |

I understand that failure to confirm the receipt of addenda may be cause for rejection of this bid. I further understand that that any verbal representation made or assumed to be made during any oral discussion held between Vendor's representatives and any state personnel is not binding. Only the information issued in writing and added to the specifications by an official addendum is binding.

Transportation Equipment Sales Corporation

\_\_\_\_\_  
Company

  
\_\_\_\_\_  
Authorized Signature

5/29/2024

\_\_\_\_\_  
Date

NOTE: This addendum acknowledgment should be submitted with the bid to expedite document processing.



WVDOT

ADDENDUM NO\_3 CRFQ DMT2400000006

---





# SOLICITATION NUMBER: CRFQ DMT2400000006

## Addendum Number: 3

The purpose of this addendum is to modify the solicitation identified as CRFQ DMT2400000006 ("Solicitation") to reflect the change(s) identified and described below.

### Applicable Addendum Category:

- Modify bid opening date and time
- Modify specifications of product or service being sought
- Attachment of vendor questions and responses
- Attachment of pre-bid sign-in sheet
- Correction of error
- Other

### Additional Documentation:

Bid Opening remains 05/30/2024 at 1:30pm

### Terms and Conditions:

1. All provisions of the Solicitation and other addenda not modified herein shall remain in full force and effect.
2. Vendor should acknowledge receipt of all addenda issued for this Solicitation by completing an Addendum Acknowledgment, a copy of which is included herewith. Failure to acknowledge addenda may result in bid disqualification. The addendum acknowledgement should be submitted with the bid to expedite document processing.

4 3.1.1.9 Water Test The Braun Corporation seeks approval of our current testing method in lieu of the method called by specification. Our water test method combines two methods of detecting leaks: Ultrasonic Sound Testing and high-pressure wash bay rinse. Ultrasonic Testing procedure is attached. The high-pressure rinse cycle shall be utilized to completely drench each vehicle with water from top, front, back, both sides and the under-frame area. Each vehicle shall be exposed to this high-pressure water spray for a continuous period of fifteen minutes. Spray nozzles shall be arranged to ensure water spray on the roof, all doors, all windows, rear wall, windshield, and in the wheel well areas under the frame. If any leaks are discovered, they will be addressed and then the vehicle will be retested.-**That is acceptable.**

9 3.14.7 BODY STRUCTURE The Voyager LX proposed will be equipped with OEM power side slide doors, in lieu of manual side slide doors as currently called out in the specification.

13 3.18.8 EXTERIOR LIGHTING Please note that The Braun Corporation conversion utilizes an interior mounted light to illuminate the area immediately around the passenger side slide door to achieve lighting compliance as required by ADA. No exterior hooded light is included.-**That is acceptable.**

20 3.29.1 WHEELCHAIR RAMP The Braun Corporation recommends that specification be amended to require that the ramp include a swing-out feature. This feature is a crucial item to facilitate ambulatory passenger entry/exit without the need to manually deploy the ramp. We suggest the following verbiage be incorporated to the existing specification: The vehicle shall be equipped with a manually operated, 80-degree (nominal) swing-away mobility access ramp which stows vertically and folds and unfolds through the passenger side slide door. The ramp swings out to provide unobstructed ambulatory passenger entry/exit.-**We accept this recommendation.**

21 3.31.5 MISC. ADDITIONS The Braun Corporation requests approved equal status for the following described Angel Trax camera package in lieu of the 6-camera package currently called by specification. The following camera package is better suited to the lowered floor minivan application: Two (2) camera video recording system. Cameras mounted to record audio and video of 1) driver area and passenger area looking from front to back; and 2) Front view camera shall be mounted facing forward out the front window. Vulcan Series 5 Channel HD/IP Mobile Digital Video Recorder, 512 GB SD Solid state Memory Card, Vulcan Series Panic Button Housing, Vulcan Series Anvil 3600 HD Low Profile Camera, Vulcan Series HDWS3600 1080P Windshield Camera, and (2) 13.12' HD Camera Cable.-**We approve.**

The Braun Corporation requests approval to offer the Infloor Simple Stow ramp as an option available for an additional cost. This item would replace the swing out ramp included in the base vehicle price. Please see attached brochure outlining the benefits of this innovative product.-**We accept this suggestion and will add the option to the list of options.**

**ADDENDUM ACKNOWLEDGEMENT FORM**  
**SOLICITATION NO.: CRFO DMT240000006**

**Instructions:** Please acknowledge receipt of all addenda issued with this solicitation by completing this addendum acknowledgment form. Check the box next to each addendum received and sign below. Failure to acknowledge addenda may result in bid disqualification.

**Acknowledgment:** I hereby acknowledge receipt of the following addenda and have made the necessary revisions to my proposal, plans and/or specification, etc.

**Addendum Numbers Received:**

(Check the box next to each addendum received)

- |  |  |
|--|--|
| <input type="checkbox"/> Addendum No. 1            | <input type="checkbox"/> Addendum No. 6  |
| <input type="checkbox"/> Addendum No. 2            | <input type="checkbox"/> Addendum No. 7  |
| <input checked="" type="checkbox"/> Addendum No. 3 | <input type="checkbox"/> Addendum No. 8  |
| <input type="checkbox"/> Addendum No. 4            | <input type="checkbox"/> Addendum No. 9  |
| <input type="checkbox"/> Addendum No. 5            | <input type="checkbox"/> Addendum No. 10 |

I understand that failure to confirm the receipt of addenda may be cause for rejection of this bid. I further understand that that any verbal representation made or assumed to be made during any oral discussion held between Vendor's representatives and any state personnel is not binding. Only the information issued in writing and added to the specifications by an official addendum is binding.

Transportation Equipment Sales Corporation  
\_\_\_\_\_  
Company

  
\_\_\_\_\_  
Authorized Signature

5/29/2024  
\_\_\_\_\_  
Date

**NOTE:** This addendum acknowledgment should be submitted with the bid to expedite document processing.



WV DOT

CRFQ DMT2400000006 Terms and Conditions

---

## **GENERAL TERMS AND CONDITIONS:**

**1. CONTRACTUAL AGREEMENT:** Issuance of an Award Document signed by the Purchasing Division Director, or his designee, and approved as to form by the Attorney General's office constitutes acceptance by the State of this Contract made by and between the State of West Virginia and the Vendor. Vendor's signature on its bid, or on the Contract if the Contract is not the result of a bid solicitation, signifies Vendor's agreement to be bound by and accept the terms and conditions contained in this Contract.

**2. DEFINITIONS:** As used in this Solicitation/Contract, the following terms shall have the meanings attributed to them below. Additional definitions may be found in the specifications included with this Solicitation/Contract.

**2.1. "Agency" or "Agencies"** means the agency, board, commission, or other entity of the State of West Virginia that is identified on the first page of the Solicitation or any other public entity seeking to procure goods or services under this Contract.

**2.2. "Bid" or "Proposal"** means the vendors submitted response to this solicitation.

**2.3. "Contract"** means the binding agreement that is entered into between the State and the Vendor to provide the goods or services requested in the Solicitation.

**2.4. "Director"** means the Director of the West Virginia Department of Administration, Purchasing Division.

**2.5. "Purchasing Division"** means the West Virginia Department of Administration, Purchasing Division.

**2.6. "Award Document"** means the document signed by the Agency and the Purchasing Division, and approved as to form by the Attorney General, that identifies the Vendor as the contract holder.

**2.7. "Solicitation"** means the official notice of an opportunity to supply the State with goods or services that is published by the Purchasing Division.

**2.8. "State"** means the State of West Virginia and/or any of its agencies, commissions, boards, etc. as context requires.

**2.9. "Vendor" or "Vendors"** means any entity submitting a bid in response to the Solicitation, the entity that has been selected as the lowest responsible bidder, or the entity that has been awarded the Contract as context requires.

**3. CONTRACT TERM; RENEWAL; EXTENSION:** The term of this Contract shall be determined in accordance with the category that has been identified as applicable to this Contract below:

**Term Contract**

**Initial Contract Term:** The Initial Contract Term will be for a period of (1) one year. The Initial Contract Term becomes effective on the effective start date listed on the first page of this Contract, identified as the State of West Virginia contract cover page containing the signatures of the Purchasing Division, Attorney General, and Encumbrance clerk (or another page identified as \_\_\_\_\_), and the Initial Contract Term ends on the effective end date also shown on the first page of this Contract.

**Renewal Term:** This Contract may be renewed upon the mutual written consent of the Agency, and the Vendor, with approval of the Purchasing Division and the Attorney General's office (Attorney General approval is as to form only). Any request for renewal should be delivered to the Agency and then submitted to the Purchasing Division thirty (30) days prior to the expiration date of the initial contract term or appropriate renewal term. A Contract renewal shall be in accordance with the terms and conditions of the original contract. Unless otherwise specified below, renewal of this Contract is limited to one successive one (1) year periods or multiple renewal periods of less than one year, provided that the multiple renewal periods do not exceed the total number of months available in all renewal years combined. Automatic renewal of this Contract is prohibited. Renewals must be approved by the Vendor, Agency, Purchasing Division and Attorney General's office (Attorney General approval is as to form only)

**Alternate Renewal Term** – This contract may be renewed for \_\_\_\_\_ successive \_\_\_\_\_ year periods or shorter periods provided that they do not exceed the total number of months contained in all available renewals. Automatic renewal of this Contract is prohibited. Renewals must be approved by the Vendor, Agency, Purchasing Division and Attorney General's office (Attorney General approval is as to form only)

**Delivery Order Limitations:** In the event that this contract permits delivery orders, a delivery order may only be issued during the time this Contract is in effect. Any delivery order issued within one year of the expiration of this Contract shall be effective for one year from the date the delivery order is issued. No delivery order may be extended beyond one year after this Contract has expired.

**Fixed Period Contract:** This Contract becomes effective upon Vendor's receipt of the notice to proceed and must be completed within \_\_\_\_\_ days.

**Fixed Period Contract with Renewals:** This Contract becomes effective upon Vendor's receipt of the notice to proceed and part of the Contract more fully described in the attached specifications must be completed within \_\_\_\_\_ days. Upon completion of the work covered by the preceding sentence, the vendor agrees that:

the contract will continue for \_\_\_\_\_ years;

the contract may be renewed for \_\_\_\_\_ successive \_\_\_\_\_ year periods or shorter periods provided that they do not exceed the total number of months contained in all available renewals. Automatic renewal of this Contract is prohibited. Renewals must be approved by the Vendor, Agency, Purchasing Division and Attorney General's Office (Attorney General approval is as to form only).

**One-Time Purchase:** The term of this Contract shall run from the issuance of the Award Document until all of the goods contracted for have been delivered, but in no event will this Contract extend for more than one fiscal year.

**Construction/Project Oversight:** This Contract becomes effective on the effective start date listed on the first page of this Contract, identified as the State of West Virginia contract cover page containing the signatures of the Purchasing Division, Attorney General, and Encumbrance clerk (or another page identified as \_\_\_\_\_), and continues until the project for which the vendor is providing oversight is complete.

**Other:** Contract Term specified in \_\_\_\_\_

**4. AUTHORITY TO PROCEED:** Vendor is authorized to begin performance of this contract on the date of encumbrance listed on the front page of the Award Document unless either the box for "Fixed Period Contract" or "Fixed Period Contract with Renewals" has been checked in Section 3 above. If either "Fixed Period Contract" or "Fixed Period Contract with Renewals" has been checked, Vendor must not begin work until it receives a separate notice to proceed from the State. The notice to proceed will then be incorporated into the Contract via change order to memorialize the official date that work commenced.

**5. QUANTITIES:** The quantities required under this Contract shall be determined in accordance with the category that has been identified as applicable to this Contract below.

**Open End Contract:** Quantities listed in this Solicitation/Award Document are approximations only, based on estimates supplied by the Agency. It is understood and agreed that the Contract shall cover the quantities actually ordered for delivery during the term of the Contract, whether more or less than the quantities shown.

**Service:** The scope of the service to be provided will be more clearly defined in the specifications included herewith.

**Combined Service and Goods:** The scope of the service and deliverable goods to be provided will be more clearly defined in the specifications included herewith.

**One-Time Purchase:** This Contract is for the purchase of a set quantity of goods that are identified in the specifications included herewith. Once those items have been delivered, no additional goods may be procured under this Contract without an appropriate change order approved by the Vendor, Agency, Purchasing Division, and Attorney General's office.

**Construction:** This Contract is for construction activity more fully defined in the specifications.

**6. EMERGENCY PURCHASES:** The Purchasing Division Director may authorize the Agency to purchase goods or services in the open market that Vendor would otherwise provide under this Contract if those goods or services are for immediate or expedited delivery in an emergency. Emergencies shall include, but are not limited to, delays in transportation or an unanticipated increase in the volume of work. An emergency purchase in the open market, approved by the Purchasing Division Director, shall not constitute a breach of this Contract and shall not entitle the Vendor to any form of compensation or damages. This provision does not excuse the State from fulfilling its obligations under a One-Time Purchase contract.

**7. REQUIRED DOCUMENTS:** All of the items checked in this section must be provided to the Purchasing Division by the Vendor as specified:

**LICENSE(S) / CERTIFICATIONS / PERMITS:** In addition to anything required under the Section of the General Terms and Conditions entitled Licensing, the apparent successful Vendor shall furnish proof of the following licenses, certifications, and/or permits upon request and in a form acceptable to the State. The request may be prior to or after contract award at the State's sole discretion.

The apparent successful Vendor shall also furnish proof of any additional licenses or certifications contained in the specifications regardless of whether or not that requirement is listed above.

**8. INSURANCE:** The apparent successful Vendor shall furnish proof of the insurance identified by a checkmark below prior to Contract award. The insurance coverages identified below must be maintained throughout the life of this contract. Thirty (30) days prior to the expiration of the insurance policies, Vendor shall provide the Agency with proof that the insurance mandated herein has been continued. Vendor must also provide Agency with immediate notice of any changes in its insurance policies, including but not limited to, policy cancelation, policy reduction, or change in insurers. The apparent successful Vendor shall also furnish proof of any additional insurance requirements contained in the specifications prior to Contract award regardless of whether that insurance requirement is listed in this section.

Vendor must maintain:

**Commercial General Liability Insurance** in at least an amount of: \$1000000.00 per occurrence.

**Automobile Liability Insurance** in at least an amount of: \$1000000.00 per occurrence.

**Professional/Malpractice/Errors and Omission Insurance** in at least an amount of: \_\_\_\_\_ per occurrence. Notwithstanding the forgoing, Vendor's are not required to list the State as an additional insured for this type of policy.

**Commercial Crime and Third Party Fidelity Insurance** in an amount of: \_\_\_\_\_ per occurrence.

**Cyber Liability Insurance** in an amount of: \_\_\_\_\_ per occurrence.

**Builders Risk Insurance** in an amount equal to 100% of the amount of the Contract.

**Pollution Insurance** in an amount of: \_\_\_\_\_ per occurrence.

**Aircraft Liability** in an amount of: \_\_\_\_\_ per occurrence.

**9. WORKERS' COMPENSATION INSURANCE:** Vendor shall comply with laws relating to workers compensation, shall maintain workers' compensation insurance when required, and shall furnish proof of workers' compensation insurance upon request.

**10. VENUE:** All legal actions for damages brought by Vendor against the State shall be brought in the West Virginia Claims Commission. Other causes of action must be brought in the West Virginia court authorized by statute to exercise jurisdiction over it.

**11. LIQUIDATED DAMAGES:** This clause shall in no way be considered exclusive and shall not limit the State or Agency's right to pursue any other available remedy. Vendor shall pay liquidated damages in the amount specified below or as described in the specifications:

\_\_\_\_\_ for \_\_\_\_\_.

Liquidated Damages Contained in the Specifications.

Liquidated Damages Are Not Included in this Contract.

**12. ACCEPTANCE:** Vendor's signature on its bid, or on the certification and signature page, constitutes an offer to the State that cannot be unilaterally withdrawn, signifies that the product or service proposed by vendor meets the mandatory requirements contained in the Solicitation for that product or service, unless otherwise indicated, and signifies acceptance of the terms and conditions contained in the Solicitation unless otherwise indicated.

**13. PRICING:** The pricing set forth herein is firm for the life of the Contract, unless specified elsewhere within this Solicitation/Contract by the State. A Vendor's inclusion of price adjustment provisions in its bid, without an express authorization from the State in the Solicitation to do so, may result in bid disqualification. Notwithstanding the foregoing, Vendor must extend any publicly advertised sale price to the State and invoice at the lower of the contract price or the publicly advertised sale price.

**14. PAYMENT IN ARREARS:** Payments for goods/services will be made in arrears only upon receipt of a proper invoice, detailing the goods/services provided or receipt of the goods/services, whichever is later. Notwithstanding the foregoing, payments for software maintenance, licenses, or subscriptions may be paid annually in advance.

**15. PAYMENT METHODS:** Vendor must accept payment by electronic funds transfer and P-Card. (The State of West Virginia's Purchasing Card program, administered under contract by a banking institution, processes payment for goods and services through state designated credit cards.)

**16. TAXES:** The Vendor shall pay any applicable sales, use, personal property or any other taxes arising out of this Contract and the transactions contemplated thereby. The State of West Virginia is exempt from federal and state taxes and will not pay or reimburse such taxes.

**17. ADDITIONAL FEES:** Vendor is not permitted to charge additional fees or assess additional charges that were not either expressly provided for in the solicitation published by the State of West Virginia, included in the Contract, or included in the unit price or lump sum bid amount that Vendor is required by the solicitation to provide. Including such fees or charges as notes to the solicitation may result in rejection of vendor's bid. Requesting such fees or charges be paid after the contract has been awarded may result in cancellation of the contract.

**18. FUNDING:** This Contract shall continue for the term stated herein, contingent upon funds being appropriated by the Legislature or otherwise being made available. In the event funds are not appropriated or otherwise made available, this Contract becomes void and of no effect beginning on July 1 of the fiscal year for which funding has not been appropriated or otherwise made available. If that occurs, the State may notify the Vendor that an alternative source of funding has been obtained and thereby avoid the automatic termination. Non-appropriation or non-funding shall not be considered an event of default.

**19. CANCELLATION:** The Purchasing Division Director reserves the right to cancel this Contract immediately upon written notice to the vendor if the materials or workmanship supplied do not conform to the specifications contained in the Contract. The Purchasing Division Director may also cancel any purchase or Contract upon 30 days written notice to the Vendor in accordance with West Virginia Code of State Rules § 148-1-5.2.b.

**20. TIME:** Time is of the essence regarding all matters of time and performance in this Contract.

**21. APPLICABLE LAW:** This Contract is governed by and interpreted under West Virginia law without giving effect to its choice of law principles. Any information provided in specification manuals, or any other source, verbal or written, which contradicts or violates the West Virginia Constitution, West Virginia Code, or West Virginia Code of State Rules is void and of no effect.

**22. COMPLIANCE WITH LAWS:** Vendor shall comply with all applicable federal, state, and local laws, regulations and ordinances. By submitting a bid, Vendor acknowledges that it has reviewed, understands, and will comply with all applicable laws, regulations, and ordinances.

**SUBCONTRACTOR COMPLIANCE:** Vendor shall notify all subcontractors providing commodities or services related to this Contract that as subcontractors, they too are required to comply with all applicable laws, regulations, and ordinances. Notification under this provision must occur prior to the performance of any work under the contract by the subcontractor.

**23. ARBITRATION:** Any references made to arbitration contained in this Contract, Vendor's bid, or in any American Institute of Architects documents pertaining to this Contract are hereby deleted, void, and of no effect.

**24. MODIFICATIONS:** This writing is the parties' final expression of intent. Notwithstanding anything contained in this Contract to the contrary no modification of this Contract shall be binding without mutual written consent of the Agency, and the Vendor, with approval of the Purchasing Division and the Attorney General's office (Attorney General approval is as to form only). Any change to existing contracts that adds work or changes contract cost, and were not included in the original contract, must be approved by the Purchasing Division and the Attorney General's Office (as to form) prior to the implementation of the change or commencement of work affected by the change.

**25. WAIVER:** The failure of either party to insist upon a strict performance of any of the terms or provision of this Contract, or to exercise any option, right, or remedy herein contained, shall not be construed as a waiver or a relinquishment for the future of such term, provision, option, right, or remedy, but the same shall continue in full force and effect. Any waiver must be expressly stated in writing and signed by the waiving party.

**26. SUBSEQUENT FORMS:** The terms and conditions contained in this Contract shall supersede any and all subsequent terms and conditions which may appear on any form documents submitted by Vendor to the Agency or Purchasing Division such as price lists, order forms, invoices, sales agreements, or maintenance agreements, and includes internet websites or other electronic documents. Acceptance or use of Vendor's forms does not constitute acceptance of the terms and conditions contained thereon.

**27. ASSIGNMENT:** Neither this Contract nor any monies due, or to become due hereunder, may be assigned by the Vendor without the express written consent of the Agency, the Purchasing Division, the Attorney General's office (as to form only), and any other government agency or office that may be required to approve such assignments.

**28. WARRANTY:** The Vendor expressly warrants that the goods and/or services covered by this Contract will: (a) conform to the specifications, drawings, samples, or other description furnished or specified by the Agency; (b) be merchantable and fit for the purpose intended; and (c) be free from defect in material and workmanship.

**29. STATE EMPLOYEES:** State employees are not permitted to utilize this Contract for personal use and the Vendor is prohibited from permitting or facilitating the same.

**30. PRIVACY, SECURITY, AND CONFIDENTIALITY:** The Vendor agrees that it will not disclose to anyone, directly or indirectly, any such personally identifiable information or other confidential information gained from the Agency, unless the individual who is the subject of the information consents to the disclosure in writing or the disclosure is made pursuant to the Agency's policies, procedures, and rules. Vendor further agrees to comply with the Confidentiality Policies and Information Security Accountability Requirements, set forth in [www.state.wv.us/admin/purchase/privacy](http://www.state.wv.us/admin/purchase/privacy).

**31. YOUR SUBMISSION IS A PUBLIC DOCUMENT:** Vendor's entire response to the Solicitation and the resulting Contract are public documents. As public documents, they will be disclosed to the public following the bid/proposal opening or award of the contract, as required by the competitive bidding laws of West Virginia Code §§ 5A-3-1 et seq., 5-22-1 et seq., and 5G-1-1 et seq. and the Freedom of Information Act West Virginia Code §§ 29B-1-1 et seq.

**DO NOT SUBMIT MATERIAL YOU CONSIDER TO BE CONFIDENTIAL, A TRADE SECRET, OR OTHERWISE NOT SUBJECT TO PUBLIC DISCLOSURE.**

Submission of any bid, proposal, or other document to the Purchasing Division constitutes your explicit consent to the subsequent public disclosure of the bid, proposal, or document. The Purchasing Division will disclose any document labeled "confidential," "proprietary," "trade secret," "private," or labeled with any other claim against public disclosure of the documents, to include any "trade secrets" as defined by West Virginia Code § 47-22-1 et seq. All submissions are subject to public disclosure without notice.

**32. LICENSING:** In accordance with West Virginia Code of State Rules § 148-1-6.1.e, Vendor must be licensed and in good standing in accordance with any and all state and local laws and requirements by any state or local agency of West Virginia, including, but not limited to, the West Virginia Secretary of State's Office, the West Virginia Tax Department, West Virginia Insurance Commission, or any other state agency or political subdivision. Obligations related to political subdivisions may include, but are not limited to, business licensing, business and occupation taxes, inspection compliance, permitting, etc. Upon request, the Vendor must provide all necessary releases to obtain information to enable the Purchasing Division Director or the Agency to verify that the Vendor is licensed and in good standing with the above entities.

**SUBCONTRACTOR COMPLIANCE:** Vendor shall notify all subcontractors providing commodities or services related to this Contract that as subcontractors, they too are required to be licensed, in good standing, and up-to-date on all state and local obligations as described in this section. Obligations related to political subdivisions may include, but are not limited to, business licensing, business and occupation taxes, inspection compliance, permitting, etc. Notification under this provision must occur prior to the performance of any work under the contract by the subcontractor.

**33. ANTITRUST:** In submitting a bid to, signing a contract with, or accepting a Award Document from any agency of the State of West Virginia, the Vendor agrees to convey, sell, assign, or transfer to the State of West Virginia all rights, title, and interest in and to all causes of action it may now or hereafter acquire under the antitrust laws of the United States and the State of West Virginia for price fixing and/or unreasonable restraints of trade relating to the particular commodities or services purchased or acquired by the State of West Virginia. Such assignment shall be made and become effective at the time the purchasing agency tenders the initial payment to Vendor.

**34. VENDOR NON-CONFLICT:** Neither Vendor nor its representatives are permitted to have any interest, nor shall they acquire any interest, direct or indirect, which would compromise the performance of its services hereunder. Any such interests shall be promptly presented in detail to the Agency.

**35. VENDOR RELATIONSHIP:** The relationship of the Vendor to the State shall be that of an independent contractor and no principal-agent relationship or employer-employee relationship is contemplated or created by this Contract. The Vendor as an independent contractor is solely liable for the acts and omissions of its employees and agents. Vendor shall be responsible for selecting, supervising, and compensating any and all individuals employed pursuant to the terms of this Solicitation and resulting contract. Neither the Vendor, nor any employees or subcontractors of the Vendor, shall be deemed to be employees of the State for any purpose whatsoever. Vendor shall be exclusively responsible for payment of employees and contractors for all wages and salaries, taxes, withholding payments, penalties, fees, fringe benefits, professional liability insurance premiums, contributions to insurance and pension, or other deferred compensation plans, including but not limited to, Workers' Compensation and Social Security obligations, licensing fees, etc. and the filing of all necessary documents, forms, and returns pertinent to all of the foregoing.

Vendor shall hold harmless the State, and shall provide the State and Agency with a defense against any and all claims including, but not limited to, the foregoing payments, withholdings, contributions, taxes, Social Security taxes, and employer income tax returns.

**36. INDEMNIFICATION:** The Vendor agrees to indemnify, defend, and hold harmless the State and the Agency, their officers, and employees from and against: (1) Any claims or losses for services rendered by any subcontractor, person, or firm performing or supplying services, materials, or supplies in connection with the performance of the Contract; (2) Any claims or losses resulting to any person or entity injured or damaged by the Vendor, its officers, employees, or subcontractors by the publication, translation, reproduction, delivery, performance, use, or disposition of any data used under the Contract in a manner not authorized by the Contract, or by Federal or State statutes or regulations; and (3) Any failure of the Vendor, its officers, employees, or subcontractors to observe State and Federal laws including, but not limited to, labor and wage and hour laws.

**37. NO DEBT CERTIFICATION:** In accordance with West Virginia Code §§ 5A-3-10a and 5-22-1(i), the State is prohibited from awarding a contract to any bidder that owes a debt to the State or a political subdivision of the State. By submitting a bid, or entering into a contract with the State, Vendor is affirming that (1) for construction contracts, the Vendor is not in default on any monetary obligation owed to the state or a political subdivision of the state, and (2) for all other contracts, neither the Vendor nor any related party owe a debt as defined above, and neither the Vendor nor any related party are in employer default as defined in the statute cited above unless the debt or employer default is permitted under the statute.

**38. CONFLICT OF INTEREST:** Vendor, its officers or members or employees, shall not presently have or acquire an interest, direct or indirect, which would conflict with or compromise the performance of its obligations hereunder. Vendor shall periodically inquire of its officers, members and employees to ensure that a conflict of interest does not arise. Any conflict of interest discovered shall be promptly presented in detail to the Agency.

**39. REPORTS:** Vendor shall provide the Agency and/or the Purchasing Division with the following reports identified by a checked box below:

Such reports as the Agency and/or the Purchasing Division may request. Requested reports may include, but are not limited to, quantities purchased, agencies utilizing the contract, total contract expenditures by agency, etc.

Quarterly reports detailing the total quantity of purchases in units and dollars, along with a listing of purchases by agency. Quarterly reports should be delivered to the Purchasing Division via email at [purchasing.division@wv.gov](mailto:purchasing.division@wv.gov).

**40. BACKGROUND CHECK:** In accordance with W. Va. Code § 15-2D-3, the State reserves the right to prohibit a service provider's employees from accessing sensitive or critical information or to be present at the Capitol complex based upon results addressed from a criminal background check. Service providers should contact the West Virginia Division of Protective Services by phone at (304) 558-9911 for more information.

**41. PREFERENCE FOR USE OF DOMESTIC STEEL PRODUCTS:** Except when authorized by the Director of the Purchasing Division pursuant to W. Va. Code § 5A-3-56, no contractor may use or supply steel products for a State Contract Project other than those steel products made in the United States. A contractor who uses steel products in violation of this section may be subject to civil penalties pursuant to W. Va. Code § 5A-3-56. As used in this section:

- a. "State Contract Project" means any erection or construction of, or any addition to, alteration of or other improvement to any building or structure, including, but not limited to, roads or highways, or the installation of any heating or cooling or ventilating plants or other equipment, or the supply of and materials for such projects, pursuant to a contract with the State of West Virginia for which bids were solicited on or after June 6, 2001.
- b. "Steel Products" means products rolled, formed, shaped, drawn, extruded, forged, cast, fabricated or otherwise similarly processed, or processed by a combination of two or more or such operations, from steel made by the open heath, basic oxygen, electric furnace, Bessemer or other steel making process.
- c. The Purchasing Division Director may, in writing, authorize the use of foreign steel products if:
  1. The cost for each contract item used does not exceed one tenth of one percent (.1%) of the total contract cost or two thousand five hundred dollars (\$2,500.00), whichever is greater. For the purposes of this section, the cost is the value of the steel product as delivered to the project; or
  2. The Director of the Purchasing Division determines that specified steel materials are not produced in the United States in sufficient quantity or otherwise are not reasonably available to meet contract requirements.

**42. PREFERENCE FOR USE OF DOMESTIC ALUMINUM, GLASS, AND STEEL:** In Accordance with W. Va. Code § 5-19-1 et seq., and W. Va. CSR § 148-10-1 et seq., for every contract or subcontract, subject to the limitations contained herein, for the construction, reconstruction, alteration, repair, improvement or maintenance of public works or for the purchase of any item of machinery or equipment to be used at sites of public works, only domestic aluminum, glass or steel products shall be supplied unless the spending officer determines, in writing, after the receipt of offers or bids, (1) that the cost of domestic aluminum, glass or steel products is unreasonable or inconsistent with the public interest of the State of West Virginia, (2) that domestic aluminum, glass or steel products are not produced in sufficient quantities to meet the contract requirements, or (3) the available domestic aluminum, glass, or steel do not meet the contract specifications. This provision only applies to public works contracts awarded in an amount more than fifty thousand dollars (\$50,000) or public works contracts that require more than ten thousand pounds of steel products.

The cost of domestic aluminum, glass, or steel products may be unreasonable if the cost is more than twenty percent (20%) of the bid or offered price for foreign made aluminum, glass, or steel products. If the domestic aluminum, glass or steel products to be supplied or produced in a “substantial labor surplus area”, as defined by the United States Department of Labor, the cost of domestic aluminum, glass, or steel products may be unreasonable if the cost is more than thirty percent (30%) of the bid or offered price for foreign made aluminum, glass, or steel products. This preference shall be applied to an item of machinery or equipment, as indicated above, when the item is a single unit of equipment or machinery manufactured primarily of aluminum, glass or steel, is part of a public works contract and has the sole purpose or of being a permanent part of a single public works project. This provision does not apply to equipment or machinery purchased by a spending unit for use by that spending unit and not as part of a single public works project.

All bids and offers including domestic aluminum, glass or steel products that exceed bid or offer prices including foreign aluminum, glass or steel products after application of the preferences provided in this provision may be reduced to a price equal to or lower than the lowest bid or offer price for foreign aluminum, glass or steel products plus the applicable preference. If the reduced bid or offer prices are made in writing and supersede the prior bid or offer prices, all bids or offers, including the reduced bid or offer prices, will be reevaluated in accordance with this rule.

**43. INTERESTED PARTY SUPPLEMENTAL DISCLOSURE:** W. Va. Code § 6D-1-2 requires that for contracts with an actual or estimated value of at least \$1 million, the Vendor must submit to the Agency a disclosure of interested parties prior to beginning work under this Contract. Additionally, the Vendor must submit a supplemental disclosure of interested parties reflecting any new or differing interested parties to the contract, which were not included in the original pre-work interested party disclosure, within 30 days following the completion or termination of the contract. A copy of that form is included with this solicitation or can be obtained from the WV Ethics Commission. This requirement does not apply to publicly traded companies listed on a national or international stock exchange. A more detailed definition of interested parties can be obtained from the form referenced above.

**44. PROHIBITION AGAINST USED OR REFURBISHED:** Unless expressly permitted in the solicitation published by the State, Vendor must provide new, unused commodities, and is prohibited from supplying used or refurbished commodities, in fulfilling its responsibilities under this Contract.

**45. VOID CONTRACT CLAUSES:** This Contract is subject to the provisions of West Virginia Code § 5A-3-62, which automatically voids certain contract clauses that violate State law.

**46. ISRAEL BOYCOTT:** Bidder understands and agrees that, pursuant to W. Va. Code § 5A-3-63, it is prohibited from engaging in a boycott of Israel during the term of this contract.

**DESIGNATED CONTACT:** Vendor appoints the individual identified in this Section as the Contract Administrator and the initial point of contact for matters relating to this Contract.

(Printed Name and Title) Blair Taseff, Regional Sales Manager

(Address) PO Box 167230, 6401 Seaman Rd, Oregon OH 43616-7230

(Phone Number) / (Fax Number) 440-653-0193

(email address) btaseff@tescobus.com

**CERTIFICATION AND SIGNATURE:** By signing below, or submitting documentation through wvOASIS, I certify that: I have reviewed this Solicitation/Contract in its entirety; that I understand the requirements, terms and conditions, and other information contained herein; that this bid, offer or proposal constitutes an offer to the State that cannot be unilaterally withdrawn; that the product or service proposed meets the mandatory requirements contained in the Solicitation/Contract for that product or service, unless otherwise stated herein; that the Vendor accepts the terms and conditions contained in the Solicitation, unless otherwise stated herein; that I am submitting this bid, offer or proposal for review and consideration; that this bid or offer was made without prior understanding, agreement, or connection with any entity submitting a bid or offer for the same material, supplies, equipment or services; that this bid or offer is in all respects fair and without collusion or fraud; that this Contract is accepted or entered into without any prior understanding, agreement, or connection to any other entity that could be considered a violation of law; that I am authorized by the Vendor to execute and submit this bid, offer, or proposal, or any documents related thereto on Vendor's behalf; that I am authorized to bind the vendor in a contractual relationship; and that to the best of my knowledge, the vendor has properly registered with any State agency that may require registration.

*By signing below, I further certify that I understand this Contract is subject to the provisions of West Virginia Code § 5A-3-62, which automatically voids certain contract clauses that violate State law; and that pursuant to W. Va. Code 5A-3-63, the entity entering into this contract is prohibited from engaging in a boycott against Israel.*

Transportation Equipment Sales Corporation

(Company) \_\_\_\_\_

(Signature of Authorized Representative) \_\_\_\_\_

Jeff Pappas, Vice-President, 5/21/2024

(Printed Name and Title of Authorized Representative) (Date) \_\_\_\_\_

419-836-2835 419-836-8460

(Phone Number) (Fax Number) \_\_\_\_\_

jpappas@tescobus.com

(Email Address) \_\_\_\_\_



WVDOT

Final\_CRFQ\_0810\_DMT2400000006\_4\_WV\_CR  
FQ\_FORM

---



Department of Administration  
 Purchasing Division  
 2019 Washington Street East  
 Post Office Box 50130  
 Charleston, WV 25305-0130

State of West Virginia  
 Centralized Request for Quote  
 Vehicles

<b>Proc Folder:</b> 1387185			<b>Reason for Modification:</b> ADDENDUM NO_3 Vendor Questions and responses
<b>Doc Description:</b> ADA Compliant Lowered Floor Minivans			
<b>Proc Type:</b> Central Master Agreement			
<b>Date Issued</b>	<b>Solicitation Closes</b>	<b>Solicitation No</b>	<b>Version</b>
2024-05-13	2024-05-30 13:30	CRFQ 0810 DMT2400000006	4

**BID RECEIVING LOCATION**

BID CLERK  
 DEPARTMENT OF ADMINISTRATION  
 PURCHASING DIVISION  
 2019 WASHINGTON ST E  
 CHARLESTON WV 25305  
 US

**VENDOR**

**Vendor Customer Code:**

**Vendor Name :** Transportation Equipment Sales Corp.

**Address :** 6401 Seaman Rd

**Street :**

**City :** Oregon

**State :** OH **Country :** USA **Zip :** 43616

**Principal Contact :** Jeff Pappas

**Vendor Contact Phone:** 419-836-2835 **Extension:**

**FOR INFORMATION CONTACT THE BUYER**

John W Estep  
 304-558-2566  
 john.w.estep@wv.gov

Vendor  
 Signature X

FEIN# 34-1029900

DATE 5/21/2024

All offers subject to all terms and conditions contained in this solicitation

**ADDITIONAL INFORMATION**

ADDENDUM NO\_3

Addendum No\_3 issued to publish and distribute the attached information to the Vendor Community

**REQUEST FOR QUOTATION:**

The West Virginia Purchasing Division is soliciting bids on behalf of the Division of Multimodal Transportation Facilities -Public Transit (DMTF-PT); and any other agency that desires to utilize this contract, to establish an open-ended contract for Americans with Disabilities Act (ADA) Compliant Lowered Floor Min-Van(s). The offered vehicles would include wheelchair securements and a deployable ramp to provide transportation services in an urban/rural environment which includes mountainous terrain and a severe weather operating climate. The offered vehicle shall be capable to perform stop-start duty cycles. Per the Bid Requirements, Specifications, Terms and Conditions attached to this solicitation.

INVOICE TO		SHIP TO	
PUBLIC TRANSIT DIVISION OF BLDG 5 RM 663  1900 KANAWHA BLVD E CHARLESTON WV US		PUBLIC TRANSIT DIVISION OF KANAWHA VALLEY REGIONAL TRANSPORTATION AUTHORITY 1550 FOURTH AVE CHARLESTON WV US	

Line	Comm Ln Desc	Qty	Unit Issue	Unit Price	Total Price
1	ADA Lowered Floor Minivans	10.00000	EA		

Comm Code	Manufacturer	Specification	Model #
25101502			

**Extended Description:**

To establish an open-ended contract for ADA Lowered Floor Minivans. These vehicles will not possess any graphics.

**SCHEDULE OF EVENTS**

Line	Event	Event Date
1	Tech Questions dur by 10:00am	2024-04-26

	Document Phase	Document Description	Page
DMT240000006	Final	ADA Compliant Lowered Floor Minivans	3

**ADDITIONAL TERMS AND CONDITIONS**

See attached document(s) for additional Terms and Conditions



WV DOT

REVISED- ADA Lowered Floor Minivans SPECS

---

REQUEST FOR QUOTATION  
ADA Compliant Lowered Floor Minivans

---

**SPECIFICATIONS**

- 1. PURPOSE AND SCOPE:** The West Virginia Purchasing Division is soliciting bids on behalf of the Division of Multimodal Transportation Facilities -Public Transit (DMTF-PT); and any other agency that desires to utilize this contract, to establish an open-ended contract for American's with Disabilities Act (ADA) Compliant Lowered Floor Min-Van(s). The offered vehicles would include wheelchair securements and a deployable ramp to provide transportation services in an urban/rural environment which includes mountainous terrain and a severe weather operating climate. The offered vehicle shall be capable to perform stop-start duty cycles.

Vehicles supplied shall conform in all respects to the applicable Motor Vehicle Laws of the State of West Virginia, Federal Motor Vehicle Safety Standards, Environmental Protection Agency, Federal and State Regulations in effect at the time of manufacture and all must be in compliance with ADA regulations at the time production of the vehicle commences.

The Vendor is to deliver a new (current year) vehicle in one of proposed floor plans as defined in these specifications with different configurations identified as Class on the Exhibit A Pricing Pages, ready for operation. All required Federal Transit Administration's certification forms must be included in the bid proposal.

- 2. DEFINITIONS:** The terms listed below shall have the meanings assigned to them below. Additional definitions can be found in section 2 of the General Terms and Conditions.
- 2.1** "ADA" means Americans with Disabilities Act of 1990 including applicable federal regulations issued pursuant to the Act in effect at the time production of the vehicle commences.
- 2.2** "ASTM" means American Society for Testing and Materials.
- 2.3** "Contract Item" or "Contract Items" means the list of items identified in Section 3.1 below and on the Pricing Pages.
- 2.4** "Curb Weight" means weight of the vehicle including maximum fuel, oil, and coolant and all equipment required for the operation as required by this specification without passengers or driver.
- 2.5** "DBA" means the decibel scale A weight to measure upper middle frequencies over time that can impact hearing loss.
- 2.6** "Division" means the West Virginia Division of Multimodal Transportation Facilities - Public Transit.
- 2.7** "DMV" means Division of Motor Vehicles State of West Virginia.

REQUEST FOR QUOTATION  
ADA Compliant Lowered Floor Minivans

---

- 2.8 “EPA” means Environmental Protection Agency.
- 2.9 “Fire Resistant” means Materials that have a flame-spread index less than 150 as measured in a radiant panel flame test per ASTM 162-75.
- 2.10 “Fireproof” means materials that will not burn or melt at temperatures less than 2,000 degrees Fahrenheit.
- 2.11 “FMVSS” means Federal Motor Vehicle Safety Standards.
- 2.12 “FTA” means Federal Transit Administration.
- 2.13 “GAWR FR” is the maximum distributed weight that may be supported by the front axle.
- 2.14 “GAWR RR” is the maximum distributed weight that may be supported by the rear axle.
- 2.15 “Gross Load” means one hundred and seventy-five (175) pounds for every design passenger seating position and for the driver and three hundred (300) pounds for every wheelchair station. Vehicles will be operated without standees.
- 2.16 “Gross Vehicle Weight Rating (GVWR)” means the maximum loaded weight (including curb weight, operator & passenger weight, and payload) in pounds (lbs.) of a single vehicle. Vehicle manufacturers specify the maximum GVWR on the vehicle certification label.
- 2.17 “HP” means the power of an engine measured in terms of a unit of power equal to 550-foot pounds per second.
- 2.18 “Manufacturer/Brand” means the name of the maker of the contract item which will be supplied by the vendor.
- 2.19 “Model & Number” means the model’s name and model number associated with the contract item as defined by the manufacturer.
- 2.20 “OEM” means Original Equipment Manufacturer.
- 2.21 “Powertrain” means the group of components used to transmit engine power to the wheels. The powertrain includes the engine, clutch, transmission, universal joints, drive shaft, and rear-axle gears.
- 2.22 “Pricing Page” means the pages, contained in wvOASIS, or attached as Exhibit A, upon which Vendor should list its proposed price for the Contract Items.
- 2.23 “QVM” means Qualified Vehicle Manufacturer.
- 2.24 “RPM” means Revolutions per minute.

REQUEST FOR QUOTATION  
ADA Compliant Lowered Floor Minivans

---

- 2.25 “SAE” means Society of Automotive Engineers.
- 2.26 “Solicitation” means the official notice of an opportunity to supply the State with goods or services that is published by the Purchasing Division.
- 2.27 “Vendor Name” means the company name of the vendor who will be supplying the contract item(s) to the Division.
- 2.28 “Warranty” means the written guarantee issued with new motor vehicles or related equipment. It defines the manufacturer’s responsibility for the repair or replacement of defective parts and other services provided as part of the purchase price. A warranty can be nullified if the user does not follow certain stipulations of the manufacturer, such as preventive maintenance.
- 2.29 “Wheelbase” means the distance from the centerline of the front axle to the centerline of the rear axle. Minimum of 121”.
- 2.30 “NTSA” means National Highway Traffic Safety Administration.
- 2.31 “DOT” means Department of Transportation.
- 2.32 “LED” means Light-Emitting Diode.

**3. GENERAL REQUIREMENTS:**

- 3.1 **Contract Items and Mandatory Requirements:** Vendor shall provide **Division** with the Contract Items listed below on an open-end and continuing basis. Contract Items shall meet or exceed the mandatory requirements as shown below.
- 3.1.1 In all cases, materials shall be furnished as specified Where brand names or specific items or processes are used in the specification, consider the term or equal to follow.
- 3.1.1.1 **Legal Requirements.** The vehicle shall meet all applicable FMVSS, DMV and ADA, federal and state regulations in effect at the date of manufacture. Vendor shall supply certification that vehicle meets all FMVSS Regulations, and that vehicle complies with all relevant federal and State of West Virginia Standards at the time of delivery.
- 3.1.1.2 **Components, Materials, Workmanship and Completeness.** These specifications reflect the Division’s preference as to dimensions, materials, and major components. However, the vendor shall not omit any part of detail which goes to make the vehicle complete and

REQUEST FOR QUOTATION  
ADA Compliant Lowered Floor Minivans

---

ready for service, even though such part or detail is not mentioned in these specifications.

- 3.1.1.3** All units or parts shall be manufacturer's best quality and shall conform in material, design and workmanship to the best practice known in the automotive industry. All parts shall be new and in no case will used, reconditioned, or obsolete parts be accepted. The parts on all vehicles provided by the same manufacturer shall be interchangeable.
- 3.1.1.4** The price quoted in any proposal submitted shall include all items of labor, material, tools, equipment, and other costs necessary to fully complete the manufacture and delivery of the vehicle pursuant to these specifications.
- 3.1.1.5** It is the intent of these specifications to provide and require a complete vehicle of the type prescribed ready for operation. The vendor shall assume sole responsibility for the entire vehicle as to warranty and after-sale parts and service.
- 3.1.1.6** Warranty to become effective on the first day, after the date of final acceptance, of each vehicle by the Division.
- 3.1.1.7** **Exhaust Emission Control Requirements.** The vehicle shall comply with all federal and state requirements applicable to the year of manufacture.

**[Regulations for Emission from Vehicles and Engines](#)**

- 3.1.1.8** **Noise Control.** The exterior noise from the vehicle shall not exceed eighty-six (86) dba using the procedures set forth in the SAE Standard SAE J366. Vendor shall supply report showing testing results of noise control. The interior noise at a location (2) feet from the rear window and four (4) feet from the floor shall not exceed eighty-six (86) dba with the vehicle standing with the transmission in neutral and the engine operating at a maximum rated RPM.
- 3.1.1.9** Body shall be thoroughly water tested and made tight to prevent leakage. All vehicles purchased under this contract shall, during the course of the manufacture and prior to acceptance, shall be subjected to a water test to

REQUEST FOR QUOTATION  
ADA Compliant Lowered Floor Minivans

---

determine body leaks. This test shall consist of a series of nozzles, which are strategically located around the perimeter of the vehicle as to spray water over the entire surface of the vehicle. The nozzles shall eject a volume of water no less than twenty-two (22) pounds per square inch measured at the nozzle tip. Body shall be thoroughly water tested and made tight to prevent leakage. The bidder shall provide the procuring agency with details of its water testing procedures with the bid.

THE PRICING AND TERMS AND CONDITIONS OF THE BID MAY BE EXTENDED TO WEST VIRGINIA TRANSIT AUTHORITIES AND PRIVATE NON-PROFIT ORGANIZATIONS. IF VENDOR DOES NOT AGREE, VENDOR MUST CLEARLY INDICATE A REFUSAL IN HIS/HER BID.

**3.2 CHASSIS**

- 3.2.1** Chassis shall be current Model year Chrysler Voyager or equivalent meeting the following specifications and accepted industry standards.

**3.3 ENGINE / EXHAUST SYSTEM**

- 3.3.1** The vehicle shall be equipped with a gasoline engine with a displacement of at least 3.0 liters and no more than 4.0 liters providing between 280 – 300 horsepower with the operating fuel expenditure being between 15-21 City and 24-30 Highway miles per gallon.

Vendor shall submit product description, warranty information, and product literature with bid.

The engine shall be installed to produce a minimum of vibration. A firewall of sandwich construction shall separate the engine and passenger compartments, providing both thermal and acoustic insulation and sealing against intrusion of exhaust fumes into the vehicle. Non-combustible insulation shall be used.

- 3.3.2** The Exhaust System shall be stainless steel type and conform with all Federal and State requirements applicable to the year of manufacture.

[Regulations for Emissions from Vehicles and Engines](#)

REQUEST FOR QUOTATION  
ADA Compliant Lowered Floor Minivans

---

**3.4 COOLING SYSTEM**

- 3.4.1** Radiator and Cooling System shall be OEM standard, with coolant recovery system utilizing 50-50 mixture of factory specified antifreeze and water.

**3.5. FUEL SYSTEM**

- 3.5.1** Fuel tank shall be OEM holding between 15 and 25 gallons of gasoline and comply with all accepted industry safety standards.

FMVSS 301

California Air Resource Board (CARB)

**3.6 TRANSMISSION**

- 3.6.1** Transmission shall be fully automatic with an electronic six to nine speed range.

- 3.6.2** Transmission shift lever shall be interlocked with starting motor to prevent engagement of starter in any gear possible other than neutral or park.

- 3.6.4** A back up camera system will be installed on each vehicle so that the area around the back of the bus is clearly displayed on a monitor that is mounted in an easily visible area for the driver.

**3.7 SUSPENSION**

- 3.7.1** Suspension system components shall be matched and tuned to provide maximum load capacity, ride quality, stability, and desirable steering and handling characteristics. The vehicle shall be tested to FMVSS 126 Electronic Stability Control Test.

**FMVSS 126 Electronic Stability Control Systems**

REQUEST FOR QUOTATION  
ADA Compliant Lowered Floor Minivans

---

- 3.7.3** Vendor must perform a front-end alignment after each vehicle is completely built. Vendor shall supply a statement of completion verifying that alignment was completed with warranty information.

**3.8 STEERING**

- 3.8.1** Power steering is required, and the power steering mechanism shall be constructed so that the vehicle can be easily steered by its operator and shall be such as to make the wheel free from road shock and vibration. The steering mechanism shall be self-centering, requiring little or no effort from the operator to bring the vehicle back to straight ahead position after turning.
- 3.8.2** With the vehicle stationary at GVW on dry, level pavement and the engine idling, steering effort shall be as low as possible at the steering wheel. This effort shall remain approximately constant from just off straight ahead to approaching full lock.
- 3.8.3** The steering geometry shall allow the turning radius maximum characteristics to be achieved in both directions.
- 3.8.5** A tilt-wheel or adjustable steering column, with cruise control is required.

**3.9 BRAKES**

- 3.9.1** The vehicle shall be equipped with 4-wheel disc brakes and a factory Anti-Lock Brake System, as well as a factory OEM parking brake assemblies and dash warning light.
- 3.9.2** Brakes shall be capable of holding a fully loaded bus on a 20 percent grade.

**3.10 WHEELS**

- 3.10.1** The vehicle shall be equipped with four OEM wheels appropriate for the vehicle's intended use.

**3.11 TIRES**

- 3.11.1** The tires shall be OEM standard as specified by the chassis size for intended use.

REQUEST FOR QUOTATION  
ADA Compliant Lowered Floor Minivans

---

**3.12 ELECTRICAL SYSTEM**

- 3.12.1** Each vehicle shall have an OEM electrical charging system
- 3.12.2** Where penetration of structural members occurs, grommets or similar devices shall be used to prevent chafing.
- 3.12.3** Schematic for all added electrical equipment that shows where added equipment was electrically attached to existing factory electric power.
- 3.12.4** Alternator: Alternator shall be factory installed heavy duty. Must be high output with a minimum of 180 amp.

**3.13 INSTRUMENTS AND CONTROLS**

- 3.13.1** The following instruments shall be provided:
  - 3.13.1.1** AM/FM digital Bluetooth /radio with clock, MP3, USB
  - 3.13.1.2** Speedometer with recording odometer
  - 3.13.1.3** Ammeter or voltammeter gauge
  - 3.13.1.4** Low-charge warning light
  - 3.13.1.5** Oil pressure gauge
  - 3.13.1.6** Fuel tank level gauge(s)
  - 3.13.1.7** Engine temperature gauge
  - 3.13.1.7** Headlight on indication and headlight high beam indicator
  - 3.13.1.8** Directional signal and flasher action light
  - 3.13.1.9** Parking Brake Indicator
  - 3.13.1.10** Power Port for Cell Phone

REQUEST FOR QUOTATION  
ADA Compliant Lowered Floor Minivans

---

**3.14 BODY STRUCTURE**

- 3.14.1** Conversion of a minivan by modifying the existing, sidewalls, and floor, shall require the construction that maintains OEM structural equivalent. All metal welded components shall be constructed by qualified operators and made corrosion resistant through a commercial primer application or through the use of stainless steel or aluminum material.
- 3.14.2** Interior Height: Conversion shall provide a minimum clearance of 60” at the vehicle center of the interior roof.
- 3.14.3** Paint: The basic vehicle factory color shall be OEM standard white.
- 3.14.4** All nuts, bolts, clips, washers, clamps, and like-parts shall be galvanized, zinc-coated, or given a coat of primer as additional protection against corrosion. All exterior screws and bolts shall be stainless steel.
- 3.14.5** Interior surfaces of any exterior painted body panels and posts which are covered by trim materials shall be given a coat of primer as additional protections against deteriorations.
- 3.14.6** All exposed surfaces and edges shall be smooth, free from burs and other projections, and shall be neatly finished.
- 3.14.7** The Minivan shall have standard OEM driver and passenger front doors. One manual left side and one manual right OEM side doors extended to floor level, and one OEM rear hatch. The manual left and right-side sliding doors shall be OEM (to the extend the sliding mobility and accessible entry door accommodates the accessible entry ramp) and extended to floor level to provide a minimum entry height of 56”. The passenger side sliding mobility aid accessible entry door shall be interlocked to the vehicle transmission and offer a minimum opening height of 56”, minimum opening width of 31” (excluding grab handle), and a maximum of 12.5” floor-to-ground height. Both sliding doors shall have a mechanism to securely hold doors in open position when vehicle is on a hill or incline.
- 3.14.8** Passenger Door Tracks: Door tracks shall be reinforced or strengthened beyond OEM standards as appropriate in all areas of contact with sliding door arms.

REQUEST FOR QUOTATION  
ADA Compliant Lowered Floor Minivans

---

- 3.14.9** Sliding Passenger Door Arms/Brackets: Reinforcement of the sliding door components shall at a minimum be adequate to support the increased weight created by the door extensions. Under normal closure conditions, there should be no evidence of door track flexing or wobbling.
- 3.14.10** Door Locks: Power with child-protection door locks for rear doors.
- 3.14.11** Rear Door Emergency Exit: the rear cargo door shall be provided with a quick release, manual override for opening the door from inside the vehicle. Capable of opening the door even if the door is locked. The vehicle's override device shall be spring loaded and mounted on the inside of the rear door to prevent accidental release. A decal shall be provided showing operating instructions.
- 3.14.12** Wheel housing shall be steel and should provide clearance for wheels equipped with chains to move freely and to allow a wheel to be removed with the vehicle jacked up as factory recommended – front or back. Rear fenders should be flexible.
- 3.14.13** The entire surface of exterior lowered floor shall have a rust inhibiting coating, such as an epoxy primer base, applied to cover all welded areas, and then a fresh application of undercoating over the entire surface. The warranty shall be 5 years on the undercoat and rustproofing. It is required that the vendor supply the description, warranty and literature information of this product with the bid.
- 3.14.14** The basic interior color shall be OEM gray, with gray (upper) and black (lower) ABS form fitted plastic panels. Panels fastening devices shall match the color of the panels. Interior panels shall meet FMVSS 302. The interior shall provide a pleasant atmosphere, be aesthetically pleasing, and contain smooth finishes without any unprotected sharp edges.

[FMVSS 302](#)

- 3.14.15** A firewall shall separate the engine and passenger compartments, providing both thermal and acoustic insulation, sealing against intrusion of exhaust gases into the vehicle and providing sufficient sound attenuation to maintain a maximum of 86db level in the passenger compartment. The firewall shall be constructed of flame resistant material.

### **3.14.16 Roof Gutters**

Water deflecting roof gutters shall be provided over ambulatory and Wheelchair accessible doors, over the passenger windows, and over the driver's windshield where necessary.

### **3.14.17 Exterior**

Paint – Surface shall be properly cleaned and primed, as appropriate, for the paint used. All exterior surfaces shall be impervious to gasoline and commercial cleaning agents. The exterior of each van shall be painted a basic white color as furnished by the chassis manufacturer. Fiberglass matching the color of the chassis is acceptable. Finished surfaces shall not be damaged by controlled application of commonly used graffiti- removing chemicals. Touch up paint for each paint color used shall be provided.

### **3.14.19 Paint Scheme**

The vehicle will be delivered without graphics, in a standard white color scheme.

## **3.15 WINDOWS**

**3.15.1** Glass shall be OEM laminated, tinted safety glass, with all latch mechanisms recessed

**3.15.2** Windshield shall be fixed type, with safety laminated glass, tinted above eye level.

## **3.16 HEATING AND VENTILATION**

**3.16.1** An OEM heating/defrosting and air conditioning system with vents front and rear shall be provided. All lines and hoses shall be sufficiently fastened protected, and insulated to ensure against wear from friction and the elements. The lines must be mechanically attached, with OEM or equivalent clamps, to the vehicle structure and must be routed so as not to be exposed to wheel spray. Cold feed lines shall not pass within 2 inches of any part of the exhaust system. Conversion shall not impede access to front and rear air conditioning components.

### **3.17 INTERIOR LIGHTING**

- 3.17.1** LED lower lighting may be added at the center row location of the vehicle that provides not less than two foot-candles of illumination at the entrance area. This system shall illuminate automatically when the vehicle front or sliding doors are open. All accessory vehicle lighting shall conform to ADA 49 CFR, Part 38, Subpart B.  
ADA 49 CFR, Part 38, Subpart B: [ADA 49 CFR, Part 38, Subpart B.](#)

### **3.18 EXTERIOR LIGHTING**

- 3.18.1** Exterior lighting shall be in accordance with Federal Motor Carrier Safety Regulations (393.11). All exterior lights to be single contact. Double contact may be used for tail, stop, and rear turn signals.

[Federal Motor Carrier Safety Regulation 393.11](#)

- 3.18.2** OEM headlights or LED headlights sealed from moisture intrusion with high and low beams controlled by a column-mounted lever switch or by a foot switch mounted on the floor, which will be sealed from moisture, are required. Headlamps units shall be of the latest type and low beam rating of 600-hour life minimum. Headlights shall be wired for daytime running. Headlights and headlight support and mountings shall be sufficiently rugged to maintain adjustments under road shock and service conditions. Headlight high beam indicator shall be installed on instrument panel. An audible "headlight on" warning buzzer shall be installed to notify the operator that the lights are on with the engine turned off.
- 3.18.3** Tail lamps shall be mounted on the rear of the vehicle so as not to be affected by engine exhaust heat. Each side shall include a hazard, signal, tail, and stop light. Lamp lenses shall not protrude from body more than two inches (2"). Lights shall consist of sealed, single unit light fixtures.
- 3.18.4** Rear tail lamps shall include a pair of amber combinational hazard and signal lights. Rear tail lamps shall also include a pair of red taillights and red stoplights, which may be combinational.

REQUEST FOR QUOTATION  
ADA Compliant Lowered Floor Minivans

---

- 3.18.5** Brake lights shall not override emergency flashers or turn signals. A collision avoidance light shall be installed on the rear at the centerline of the vehicle. It shall be activated simultaneously with the stop lamp circuit.
- 3.18.6** Two (2) back-up lights adequate to illuminate for visibility when backing shall be furnished. One mounted on each side of the vehicle. The lamps shall each be a sealed, single unit light fixture.
- 3.18.7** Passenger entry door area shall adequately illuminate with either an exterior light or interior mounted light to illuminate the area immediately around the passenger side slide door.
- 3.18.8** Each vehicle shall be equipped with an exterior curb lamp. Light shall be positioned in manufacturer's standard location in such a manner as to illuminate the ground area in the immediate vicinity of the area of operation of the wheelchair lift. Light shall be automatically activated only when the wheelchair lift doors are open. Illumination shall be sufficient to comply with ADA requirements.

**3.19 INTERIOR DECALS**

- 1) **"No Smoking"** at the front top of vehicle.
- 2) **"All Passengers Are Required To Wear Seat Belts When Vehicle Is In Motion"** at the front top of the vehicle.
- 3) **"Clearance \_\_\_\_\_ feet \_\_\_\_\_ inches"**  
above driver's visor. (The specific figures on clearance will be determined by exact dimensions of vehicle.)
- 4) **Emergency Dial 911:**
- 5) **EMERGENCY EQUIPMENT** - Apply to the First Aid Kit.

**3.20 EXTERIOR DECALS:**

- 1) **"This Vehicle Makes Frequent Stops"** on the back of the vehicle.
- 2) The International Wheelchair Accessibility Symbol on the back of the vehicle.

REQUEST FOR QUOTATION  
ADA Compliant Lowered Floor Minivans

---

- 3) "**CAUTION: Loading and Unloading Passengers**" on the back of vehicle.

The exterior decals shall have 3" lettering shall be white letters on red black ground.

### **3.21 SEATING**

All seats in the vehicle as specified must comply with current FMVSS standards.

#### [FMVSS Standard 207 Seating System](#)

- 3.22.1 Front Seats:** The driver seat will be OEM and mounted to the vehicle floor.

The OEM front passenger seat shall be equipped to easily lock/unlock from the floor and permit easy roll out for mobility aid access/securement.

- 3.22.2 Rear Seat:** The third row 3-passenger bench seat shall be the OEM seat, remounted to be capable of accommodating 3 adult passengers, and is to be covered with OEM upholstery to match the driver and front passenger seats. A manually operated one-piece lighted footrest will be installed for increased comfort of rear bench seat passengers.

- 3.22.3 Passenger Restraint:** Restraints shall be furnished for all passengers, consisting of shoulder seatbelts and/or lap belts. Each belt shall be equipped with an automatic retractor. Securement devices, both for ambulatory and mobility aid passengers, shall meet all State and Federal Standards.

#### [49 CFR Standard No. 210](#)

- 3.22.4 Grab Handles:** Grab handle shall be installed, OEM are acceptable.

### **3.22 ALTOONA BUS TESTING REPORT**

The converted minivan must have been submitted to the Altoona Bus Test Center for a 4 year/ 100,000-mile Surface Transportation and Uniform Relocation Assistance Act (STURAA) test. Testing must have been completed on current body style being converted. A copy of the test report should be submitted with the Vendor's submitted bid

REQUEST FOR QUOTATION  
ADA Compliant Lowered Floor Minivans

---

response. This information may be required before award of contract.

[FTA Bus Testing Standard](#)

**3.23 EMERGENCY/SAFETY EQUIPMENT**

**3.24.1** First Aid Kit - First-Aid Kit shall comply with Federal Motor Vehicle Carrier Safety Regulations Part 393(h), Section 393, Part 96(c), with a minimum of 15 units. First-aid kits shall be stored in storage compartment or mounted so as to provide for easy access in the event of an accident, away from foot traffic.

[Federal Motor Carrier Safety Administration Emergency Equipment](#)

**3.24.2** Kit shall be housed in a metal box which contains at least the following items:

- 3.24.2.1** Instant Cold Pack (1)
- 3.24.2.2** Certicaine Burn Spray (1 oz.)
- 3.24.2.3** 1" x 3" Adhesive Bandages (25)
- 3.24.2.4** 3/4" x 3" Adhesive Bandages (10)
- 3.24.2.5** Extra Large Adhesive Bandages (10) 3" x 3"
- 3.24.2.6** Gauze Pads (10)
- 3.24.2.7** Antiseptic Wipes (10)
- 3.24.2.8** Alcohol Prep Pads (20)
- 3.24.2.9** Ammonia Inhalants (10)
- 3.24.2.10** 2" x 6 yds. Gauze Bandage
- 3.24.2.11** 1/2" x 2.5 yds. Adhesive Tape
- 3.24.2.12** Burn Ointment (1/8 oz.) (4)
- 3.24.2.13** Insect Sting Swabs (4)
- 3.24.2.14** PVP Iodine Swabs (4)
- 3.24.2.15** Tweezers (1)

REQUEST FOR QUOTATION  
ADA Compliant Lowered Floor Minivans

---

**3.24.2.16** Scissors (1)

**3.24.2.17** Safety Pins (5)

**3.24.3** Fire Extinguisher - A 5 lb. dry chemical fire extinguisher with a minimum of a 20-A: 180-B:C rating shall be provided in vehicle and shall be mounted in an access compartment with a hinged door or on a vehicular-type quick access bracket away from foot traffic.

**3.24.4** Reflectors - Three bi-directional emergency reflective triangles conforming to requirements of FMVSS No. 125, Section 571.125 shall be secured in the storage compartment of the vehicle.

[FMVSS No. 125, Section 571.125](#)

**3.24.5** Jumper Cables - Jumper cables of stranded copper, 4-6 gauge, seven (7) feet minimum length shall be secured in the storage compartment of the vehicle.

**3.24.6** Bloodborne Pathogen Protection Kit - A 10-unit (minimum) kit housed in a polypropylene or metal box and containing at least the following items:

**3.24.6.1** Gown/Cap (1)

**3.24.6.2** Goggles (Eye Shield) (1)

**3.26.6.3** Mask (1)

**3.26.6.4** Sets of Gloves (3)

**3.26.6.5** Scraper (1)

**3.26.6.6** Crepe Towels (2)

**3.26.6.7** Antiseptic Towelettes (4)

**3.26.6.8** Disinfectant Towelette (4)

**3.26.6.9** Mouth to Mouth Barrier (1)

**3.26.6.10** Scoop Bag (3)

**3.26.6.11** Infectious Liquid Control Powder (2 oz.)

**3.26.6.12** Red Bio-Hazard Bags with Ties (2)

REQUEST FOR QUOTATION  
ADA Compliant Lowered Floor Minivans

---

**3.24.7** Wheel Jack & Lug Wrench secured in a location approved by the Division of Public Transit.

**3.24.8** Seat Belt Cutter – shall be secured in the storage compartment of the vehicle.

**3.24 MIRRORS**

**3.25.1** Interior OEM Rearview Mirror.

**3.25.2** Exterior Two rearview, one right and one left power adjustable mirrors to be installed. If not OEM, it is required that the vendor supply the description, warranty and literature information of this product with the bid.

**3.25 FRONT AND REAR HEATING AND AIR CONDITINING**

**3.26.1** An OEM heating/defrosting and air condition system with vents front and rear shall be provided. All lines and hoses shall be sufficiently fastened, protected, and insulated to ensure against wear from friction and the elements. The lines must be mechanically attached with OEM clamps, to the vehicle structure at no greater than 18-inch intervals and must be routed so as not to be exposed to wheel spray and not pass within 2 inches of any part of the exhaust system. Conversion shall not impede access to front and rear air condition components.

**3.26 WHEELCHAIR SECUREMENT SYSTEM**

**3.27.1** It is required that the vendor supply the description, warranty and literature information of this product with the bid.

**3.27.2** Wheelchair securement areas and systems shall fully comply with all applicable U.S. Department of Transportation's Americans with Disabilities Requirements. NHTSA requires a 3-point shoulder restraint system shall be supplied for each passenger for vehicles under 10,000 GVWR.

**3.27.3** Vehicle shall be equipped with one (1) wheelchair position. Each required wheelchair position a wheelchair securement system shall be provided to securely hold the wheelchair in the wheelchair position.

**3.27.4** Provisions shall be made, in the wheelchair position area, to stow the straps and buckles off the floor when they are not in use. The stored straps shall not interfere with passenger movement or sitting space. Vendor shall

REQUEST FOR QUOTATION  
ADA Compliant Lowered Floor Minivans

---

submit description and location of product with bid.

- 3.27.5** The vendor shall provide with each vehicle upon delivery a pamphlet, brochure or similar literature describing and instructing the use of the wheelchair securement system and shall demonstrate to the recipient the proper method of using the system. Demonstration of the securement system must be performed to insure correct use of the system.
- 3.27.6** A Freedman Seating 3 Step Forward Facing Fold Down Double Seat, or equal, shall be used in every wheelchair position for use by non-disabled persons when the securement system is not needed. When folded up, the seat shall not interfere with the use of the wheelchair positions by passengers in wheelchairs. An under-seat retractable seat belt shall be provided for each seated position.
- 3.27.7** The wheelchair station shall have a securement system fully complying with ADA requirements and capable of securing most common wheelchairs and other mobility aid devices. Each wheelchair space shall have at least 3-5” in between each space for easy access of driver.

**3.28 WHEELCHAIR OCCUPANT RESTRAINT SYSTEM**

- 3.28.1** A restraint system shall be provided for the occupant of the wheelchair at each wheelchair position. The restraint system shall be a seat belt assembly permanently attached to the floor or side of the vehicle or to the wheelchair lock supports. The restraint system shall be capable of securing a passenger in all types of wheelchairs or Scooters, while the chairs are locked in position. The seat belt shall be at least eighty (80) inches long and shall be easily fastened and unfastened by the wheelchair occupant. Each seat belt shall be equipped with a retractor or other device, which keeps the seat belt webbing or strap off the floor when the seat belt is not in use.
- 3.28.2** A complete retractable wheelchair and occupant restraint system with S-Hooks shall be installed at the wheelchair location. The system will have automatic belt retractors; tensioning knobs; and easy to use tension release mechanisms. The system shall be a Titan AL712S-4C; Q-Straint QRT Deluxe or approved equal. L-Track System to be used.
- 3.28.2.1** Wheelchair retractors shall be fully automatic, auto locking and self- tensioning.

REQUEST FOR QUOTATION  
ADA Compliant Lowered Floor Minivans

---

- 3.28.2.2** Retractors shall automatically remove any slack in the webbing after they are secured to the wheelchair.
- 3.28.2.3** Retractors are self-retracting; therefore, no belts are left on the floor, keeping them cleaner and longer lasting.
- 3.28.2.4** Retractor shall have a “LOCKED” indicator tag and shall only be visible when the retractor is in the LOCKED mode assuring the retractor is not in the release condition when properly secured to the wheelchair.
- 3.28.2.5** Retractors shall be heavy duty with heat treated structural components and plated for superior corrosion resistance.
- 3.28.2.6** Retractors shall have appropriately finished metal cover for long lasting protection.
- 3.28.2.7** Retractors shall have colored webbing and the occupant restraints shall be of a contrasting color for easy identification in the field.
- 3.28.2.8** Retractors shall be designed to be low profile to fit under most wheelchair footrests.
- 3.28.2.9** Retractors shall be equipped with anchoring points for the attachment of the occupant restraint lap belts.
- 3.28.2.10** Retractors shall be able to be used with a variety of shoulder/lap Belt combinations.
- 3.28.2.11** Retractors shall have manual knobs for additional tightening if needed.
- 3.28.2.12** Retractor shall be able to secure a wheelchair with one hand in as little as 10 seconds.
- 3.28.2.13** Retractors shall have a warranty period of at least the industry standard and shall have a manufacturing label to identify the part number and date of manufacture for easy traceability.
- 3.28.2.14** Retractors, occupant restraints and anchoring equipment shall be installed in accordance with the manufacturer’s installation instructions and recommendations.
- 3.28.2.15** Retractors and occupant restraints shall meet or exceed but not limited to the following specifications:

REQUEST FOR QUOTATION  
ADA Compliant Lowered Floor Minivans

---

[SAE J2249](#)

[ISO 10542](#)

[National Standard for School Buses Standard 222](#)

[ADA 49 CFR Part 38](#)

[FMVSS 209](#)

[FMVSS 302](#)

[Canadian Z605](#)

It is required that the vendor supply the description, warranty and literature information of this product with the bid.

**3.29 WHEELCHAIR RAMP:**

**3.29.1** The vehicle shall be equipped with a manually operated access ramp which stows vertically or under the floor and is deployed through the right-side sliding door. The fold and unfold motion of the ramp must be counter balanced so that the operator can easily deploy the ramp. The installed ramp shall not obstruct the view of the driver through any vehicle window. The ramp shall have a minimum usable width of 30” and a slope meeting the requirements of ADA, 49 CFR. The ramp surface shall be continuous and made skid resistant. It shall accommodate both four-wheel and three-wheel mobility aids. The ramp shall have a rated capacity of 1000 lbs. and possess industry standard protective features.

[ADA CFR 49](#)

**3.30 AM/FM DIGITAL BLUETOOTH/ RADIO WITH CLOCK**

Vehicle shall be equipped with the OEM’s AM/FM radio/USB/MP3 stereo with with Bluetooth connectivity.

**3.31 MISCELLANEOUS ADDITIONS**

**3.31.1** Each vehicle shall be equipped with rear window defroster.

**3.31.2** Each vehicle shall have installed power windows and locks on all doors.

**3.31.3** Each vehicle shall be equipped with driver and passenger air bags.

REQUEST FOR QUOTATION  
ADA Compliant Lowered Floor Minivans

---

**3.31.4** Each vehicle shall be equipped with a sun visor for driver and front passenger that is able to pivot to cover their doors.

**3.31.5** Provide and install in each vehicle Angel Trax Vulcan Series V12 HD IP Mobile DVR Security Camera System with 6 cameras or equivalent having One TB SATA Hard drive with back up recording on SD Card and six audio/video channels or equivalent.

**3.32 MANUALS**

The vendor shall furnish each vehicle with complete driver, parts and maintenance manuals, including AS-BUILT wiring schematics of auxiliary circuits, air line diagrams and all other necessary prints for the maintenance of the wheelchair lift, auxiliary air conditioning unit and any other optional items added by the vendor during conversion.

**3.33 UNSPECIFIED ACCESSORIES & FEATURES**

All parts, equipment, accessories, material, design and performance characteristics not specified herein, but which are necessary to provide a complete unit, must be furnished with each unit and required to confirm to strength, quality of material, and quality of workmanship to those which are advertised and provided to the market in general by the unit industry. All parts and accessories advertised and regularly supplied as standard shall be included, except those which would represent duplication of these specified and except those which, by specification, are not to be furnished. All standard safety features, required by Federal and State Law, shall be included. Vehicles must have all equipment found on the manufacturer's base model plus other equipment requirements, packages, items, etc. needed to meet the specifications.

**4 REQUIREMENTS SPECIFIC TO EACH VEHICLE CLASS**

4.1 Class A: Vehicles identified as Class A vehicles must meet the following mandatory requirements in addition to the requirements listed in Section 3. Class A Vehicle will NOT have any Striping or Logo's, Painted White.

**4.1.1 Measurements and Other Specifications:**

GVWR	6,000 minimum
WHEELBASE	121" Minimum
SEAT/WHEELCHAIR CAPACITY	Five / One
PASSENGER HEAT & A/C	OEM Front & Rear System
ENGINE TYPE	Gasoline
ENGINE CAPACITY	Displacement of at least 3.0 liters and no more than 4.0 liters providing between 280 – 300

REQUEST FOR QUOTATION  
ADA Compliant Lowered Floor Minivans

---

	horsepower with the operating fuel expenditure being between 15-21 City and 24-30 Highway miles
BRAKES	4 Wheel Disc / Anti-Lock System
BATTERY	OEM
WHEELCHAIR RAMP	Manual / Right Side

5 ADDITIONAL REQUIREMENTS APPLICABLE TO ALL VEHICLES

5.1 Summary of Items To Be Provided Upon Delivery

The following items shall be furnished by the successful Vendor upon delivery of the vehicle:

- a. All warranty verification vouchers, certificates or coupons.
- b. Supply two (2) sets of the following manuals, per model year, for each transit authority that receives vehicles:

- Two (2) complete parts books
  - Two (2) maintenance manuals
  - Including wiring schematics of auxiliary circuits and all other necessary prints for the maintenance of the vehicle and
  - One (1) OEM operations manual

- For other agencies receiving vehicles, the successful bidder shall supply one (1) copy of each mentioned per vehicle.

- c. Completely filled fuel tank or tanks.
- d. Protection to 20° F below zero with permanent type antifreeze.
- e. A vehicle(s) free of dealer signs and emblems.
- f. Assurance of compliance with manufacturer's pre-delivery service.
- g. A vehicle(s) which is clean, (If delivery of the vehicle occurs during the winter months of October through March, the vehicle shall be washed directly prior to delivery at designated recipient or Kanawha Valley Regional Transportation Authority to ensure that the vehicle is free of dirt and salt deposits) lubricated, serviced and ready for immediate service.
- h. Operation, maintenance and warranty information for any add on equipment will be provided upon delivery if available to the Vendor.

REQUEST FOR QUOTATION  
ADA Compliant Lowered Floor Minivans

---

- i. Original vehicle chassis manufacturer's factory sticker itemizing equipment on the vehicle.
- j. A certified weight slip showing front and drive axle weights for the vehicle at its curb weight as defined in Technical Specifications.
- k. Proof of Alignment.
- l. Vehicle shall comply with and conform to the State of West Virginia Motor Vehicle Inspection Law and shall have the current inspection sticker attached to the windshield.

**5.2 Title**

Adequate documents for securing the vehicle in the name of the Division shall be provided to the Division at least 10 working days prior to the delivery of each vehicle. The Vendor warrants that the title shall pass to the Division free and clear of all liens, mortgages and encumbrances, financing statements, security agreements, claims and demands of any character.

According to WV State Code §5A-3-4(8), vendor agrees that liquidated damages shall be imposed at the rate of \$10 per calendar day for failure to provide the titling documentation at the time of vehicle delivery. This clause shall in no way be considered exclusive and shall not limit the State or agency's right to pursue any other additional remedy to which the State or agency may have legal cause for action including further damages against the vendor.

All documentation (Certificate of Origin, Delivery/Odometer Statement, Etc.) in original form must be mailed or hand carried to:

WV Division of Multimodal Transportation Facilities -  
Public Transit  
1900 Kanawha Blvd., East  
Building 5, Room 663  
Charleston, WV 25305

### 5.3 QUALITY ASSURANCE

#### 5.3.1 QUALITY ASSURANCE ORGANIZATION

The Vendor shall establish and maintain an effective quality assurance organization. It shall be a specifically defined organization and should respond directly to the Vendor's management. The Vendor's complete quality assurance program for purchased components and in-plant inspection procedures shall be available for review by the Division prior to award.

##### Control

The quality assurance organization shall exercise quality control over all phases of production from initiation of design through manufacture and preparation for delivery. The organization shall also control the quality of supplied articles.

##### Authority and Responsibility

The quality assurance organization shall have the authority and responsibility for reliability, quality control, inspection planning, establishment of the quality control system, and acceptance/rejection of materials and manufactured articles in the production of the vehicles.

#### 5.3.2 QUALITY ASSURANCE ORGANIZATION FUNCTIONS

The quality assurance organization shall include the following minimum functions.

##### Work Instructions

The quality assurance organization shall verify inspection operation instructions to ascertain that the manufactured product meets all prescribed requirements.

##### Records Maintenance

The quality assurance organization shall maintain and use records and data essential to the effective operation of its program. These records and data shall be available for review by the resident inspectors. Inspection and test records for this procurement shall be available for a minimum of one (1) year after inspections and test are completed.

##### Corrective Actions

The quality assurance organization shall detect and promptly assure correction of Any condition that may result in the production of defective vehicles. These conditions may occur in designs, purchases, manufacture, tests, or operations that

culminate in defective supplies, facilities, technical data, or standards.

### **5.3.3 STANDARDS AND FACILITIES**

#### **Configuration Control**

The Vendor shall maintain drawings and other documentation that completely describe a quality vehicle that meets all of the options and special requirements of this procurement. The quality assurance organization shall verify that each vehicle is manufactured in accordance with these controlled drawings and documentation.

#### **Measuring and Testing Facilities**

The Vendor shall provide and maintain the necessary gauges and other measuring and testing devices for use by the quality assurance organization to verify that the vehicles conform to all specification requirements. These devices shall be calibrated at established periods against certified measurement standards that have known valid relationships to national standards.

#### **Production Tooling as Media of Inspection**

When production jigs, fixtures, tooling master patterns, and other devices are used as media of inspection, they shall be proved for accuracy at formally established intervals and adjusted, replaced, or repaired as required to maintain quality.

#### **Equipment Use By Division's Inspector(s)**

The Vendor's gauges and other measuring and testing devices shall be made available for use by the Division's inspector(s) to verify that the vehicles conform to all specification requirements. If necessary, the Vendor's personnel shall be made available to operate the devices and to verify their condition and accuracy.

### **5.3.4 CONTROL OF PURCHASES**

The Vendor shall maintain quality control of purchases.

#### **Supplier Control**

The Vendor shall require that each supplier maintains a quality control program for the services and supplies that it provides. The Vendor's quality assurance organization shall inspect and test materials provided by suppliers for conformance to specification requirements. Materials that have been inspected, tested, and approved shall be identified as acceptable to the point of use in the manufacturing or assembly processes. Controls shall be established to prevent inadvertent use of non-conforming materials.

REQUEST FOR QUOTATION  
ADA Compliant Lowered Floor Minivans

---

**Purchasing Data**

The Vendor shall verify that all applicable specification requirements are properly included or referenced in purchases of articles to be used on vehicles.

**5.3.5 MANUFACTURING CONTROL**

The Vendor shall ensure that all basic production operations, as well as all other processing and fabricating, are performed under controlled conditions, establishment of these controlled conditions shall be based on the documented work instructions, adequate production equipment, and special working environments if necessary.

**Completed Items**

A system for final inspection and test of completed vehicles shall be provided by the quality assurance organization. It shall measure the overall quality of each completed vehicle.

**Non-conforming Materials**

The quality assurance organization shall monitor the Vendor's system for controlling non-conforming materials. The system shall include procedures for identification, segregation, and disposition.

**Statistical Techniques**

Statistical analysis, tests, and other quality control procedures may be used when appropriate in the quality assurance processes.

**Inspection Status**

A system shall be maintained by the quality assurance organization for identifying the inspection status of components and completed vehicles. Identification may include cards, tags, or other normal quality control devices.

**5.3.6 INSPECTION SYSTEM**

The quality assurance organization shall establish, maintain, and periodically audit a fully documented inspection system. The system shall prescribe inspection and test of materials, work in progress and completed articles. At a minimum, it shall include the following controls.

REQUEST FOR QUOTATION  
ADA Compliant Lowered Floor Minivans

---

**Inspection Stations**

Inspection stations shall be at the best locations to provide for the work content and characteristics to be inspected. Stations shall provide the facilities and equipment to inspect structural integrity; electrical; hydraulic; through floor securements; OEM defects; coverage of the undercoating; and other components and assemblies for compliance with the design requirements.

Stations shall also be at the best locations to inspect or test characteristics before they are concealed by subsequent fabrication or assembly operations. These locations shall minimally include, as practicable, underbody structure completion, body framing completion, body prior to paint preparation, water test before interior trim and insulation installation, engine installation completion, underbody dress-up and completion, vehicle prior to final paint touch up, vehicle prior to road test, and vehicle final road test completion.

The manufacturer shall provide on its premises a suitable means for a complete inspection of the underside of the vehicle.

**Inspection Personnel**

Sufficiently trained inspectors shall be used to ensure that all materials, components, and assemblies are inspected for conformance with the qualified vehicle design.

**Inspection Records**

Acceptance, rework, or rejection identification shall be attached to inspected articles. Articles that have been accepted as a result of approved materials review actions shall be identified. Articles that have been reworked to specified drawing configurations shall not require special identification. Articles rejected as unsuitable or scrap shall be plainly marked and controlled to prevent installation on the vehicle. Articles that become obsolete as a result of engineering changes for other actions shall be controlled to prevent unauthorized assembly or installation. Unusable articles shall be isolated and then scrapped.

Discrepancies noted by the Vendor or Division's inspector during assembly shall be entered by the inspection personnel on a record that accompanies the major component, subassembly, or vehicle from start of assembly through final inspection. Actions shall be taken to correct discrepancies or deficiencies in the manufacturing processes, procedures, or other conditions that cause articles to be in nonconformity with the requirements of the contract specifications. The inspection personnel shall verify the corrective actions and mark the discrepancy record. If discrepancies cannot be corrected by replacing the non-conforming materials, the

REQUEST FOR QUOTATION  
ADA Compliant Lowered Floor Minivans

---

Division shall approve the modification, repair, or method of correction to the extent that the contract specifications are affected.

**Quality Assurance Audits**

The quality assurance organization shall establish and maintain a quality control audit program. Records of this program shall be subject to review by the Division.

**Division's Inspector(s)**

The Division may be represented at the Vendor's plant by their inspectors, they shall monitor, in the Vendor's plant, the manufacture of vehicles built under this procurement. The Division's inspectors shall be authorized to release the vehicles for delivery. Upon request to the quality assurance supervisor, inspectors shall have access to the Vendor's quality assurance files related to this procurement. These files shall include drawings, material standards, parts lists, inspection processing and reports, and records of defects. The presence of these inspectors in the plant shall not relieve the Vendor of its responsibility to meet all of the requirements of this procurement.

The Division's inspectors shall not have the authority to stop the Vendor's production line until any apparent problem area of major significance that arises to warrant such actions is fully discussed with the Vendor's top management.

**5.4 SERVICE AND PARTS**

The Vendor shall state on Bid Form #1 the representative(s) responsible for assisting the Recipient Agencies, as well as, the location of the nearest distribution center(s) which shall furnish a complete supply of parts and components for the repairs and maintenance of the vehicles to be supplied.

**5.5 Materials and Workmanship**

- a. Vendor shall incorporate in the proposed vehicle(s) the latest technological achievements consistent to achieving maximum service life and superior attractiveness of appearance.
- b. Vehicle(s) shall be delivered in new, first-class condition, complete and ready for operation on the street and the Vendor shall assume all responsibility and liability incident to said delivery.
- c. All materials used in the construction of vehicle(s) and in all its parts and accessories shall conform to A.S.T.M., S.A.E., or similar associations published standards, and be of top quality.

REQUEST FOR QUOTATION  
ADA Compliant Lowered Floor Minivans

---

- d. The vehicle(s) shall be built with suitable and easily accessible compartments provided for all apparatus, sound deadening insulation, wherever needed, and all operating devices so mounted as to reduce and keep all noise and vibration to an absolute minimum.
- e. Vendor shall assume responsibility for all material and accessories used in vehicle(s) and their proper installation and their warranty, whether the same is manufactured by the Vendor or purchased ready-made from a source outside the Vendor's company.

**5.6 Spare Parts** – The Vendor shall guarantee the availability of replacement parts for these vehicles for at least a seven (7) year period after the date of acceptance. Spare parts shall be interchangeable with the original equipment and shall be manufactured in accordance with the quality assurance provision of this contract.

**5.7 Engineers** – The Vendor shall, at its own expense, have a competent engineering representative(s) available on request to assist the Recipient Agencies staff in the solution of engineering or design problems within the scope of the specifications that may arise during the warranty period.

**5.8 Documents** –The Vendor shall keep maintenance manuals available for a period of ten (10) years after the date of acceptance of the vehicles procured under this contract. The Vendor shall also keep parts books up to date for a period of ten (10) years. The supplied maintenance and operators' manuals shall incorporate all equipment ordered on the vehicles covered by this procurement.

## **5.9 WARRANTIES**

The Vendor has an obligation to ensure that the entire vehicle is covered by a warranty. The Vendor shall make every effort to assure that all obligations defined under all warranties applicable to the vehicle or any subpart of the vehicle are unfilled.

### **5.9.1 WARRANTY REQUIREMENTS**

Warranties in this document are in addition to any statutory remedies or warranties imposed on the Vendor. Consistent with this requirement the Vendor warrants and guarantees to the Division each complete vehicle, and specific subsystems and components as follows:

#### **5.9.2 Complete Vehicle**

The vehicle is warranted and guaranteed to be free from defects and related defects for three (3) years or 36,000 miles, whichever comes first, beginning on the first day after the date of final acceptance of each vehicle. During this warranty period, the vehicle shall maintain its structural and functional integrity. The warranty is based on regular operation of the vehicle under the operating conditions prevailing in the Recipient Agencies locales.

### **5.9.2 Warranty of Basic Vehicle Structure**

The Vendor shall warranty the frame and suspension members for three (3) years or 36,000 miles, whichever comes first. This warranty shall not cover air bags, leveling valves, springs or other normal wearing parts. The Vendor is not liable for warranty if the Recipient Agencies voids the warranty as outlined in this Section. If the frame or suspension fails or shows indication of imminent failure, the Recipient Agencies will immediately notify the Vendor of said defect. Within ten (10) calendar days the Vendor will inform the Recipient Agencies on how the Vendor will repair the vehicle. Repair of frame and suspension failures will be the responsibility of the Vendor. Within fifteen (15) calendar days from notification of the defect the Vendor shall begin the repair of the frame and suspension defects. If the vehicle with the reported frame and suspension defect is out of revenue service for more than twenty (20) calendar days because of the reported defect, the Vendor will have to either provide a substitute vehicle of equal seating capacity with wheelchair lift (if applicable) of the same age or newer than the vehicle with the defect or directly reimburse the Recipient Agencies the cost of leasing a substitute vehicle. The maximum daily reimbursement will be \$300. The Vendor will have to continue to provide a substitute vehicle or reimburse the Recipient Agencies until the defect is completely repaired.

### **5.9.3 Warranty Locations**

A description of how and by whom warranty service is to be provided in four (4) areas of West Virginia is to be included in the bid proposal. The information should cover both mechanical and body work. All bidders shall provide vendors who will do the warranty of both chassis and body, including vehicle body, air conditioning and wheelchair lifts. The four warranty service areas of West Virginia include: The Northern Panhandle, Eastern Panhandle, Central West Virginia and Southern West Virginia.

### **5.9.4 Subsystems and Components**

The subsystems and components are warranted and guaranteed to be free from defects and related defects as follows:

ENGINE: Three (3) years or 36,000 miles, whichever comes first.

TRANSMISSION: Three (3) years or 36,000 miles, whichever comes first.

DRIVE AXLE: Three (3) years or 36,000 miles, whichever comes first.

BRAKE SYSTEM: Excluding friction material,  
Three (3) years or 36,000 miles  
whichever comes first

REQUEST FOR QUOTATION  
ADA Compliant Lowered Floor Minivans

---

BASIC BODY     Three (3) years or 36,000  
STRUCTURE     miles, whichever comes first..  
INTEGRITY:

AIR CONDITIONING     Three (3) years or 36,000 miles  
SYSTEM:

WHEELCHAIR     Two (2) years  
RAMP SYSTEM:

ALL ADD ON COMPONENTS: Two (2) years, unlimited miles

**5.9.5 VOIDING OF WARRANTY**

The warranty shall not apply to any part or component of the vehicle that has been subject to misuse, negligence, accident, or that has been repaired or altered in any way so as to affect adversely its performance or reliability, except insofar as such repairs were in accordance with the Vendor's maintenance manuals and the workmanship was in accordance with recognized standards of the industry. The warranty shall also be void if the Recipient Agencies fails to conduct normal inspections and scheduled preventative maintenance procedures as recommended in the Vendor's maintenance manuals.

**5.9.6 EXCEPTIONS TO WARRANTY**

The warranty shall not apply to scheduled maintenance items, and items such as tires and tubes, nor to items furnished by the Recipient Agencies such as radios, fare boxes and other auxiliary equipment, except insofar as such equipment may be damaged by the failure of a part or component for which the Vendor is responsible.

**5.9.7 DETECTION OF DEFECTS**

If the Recipient Agency detects a defect within the warranty periods defined in Section 5.10.1 of this Part, it shall promptly notify the Vendor's representative five (5) working days after receipt of notification, the Vendor's representative shall either agree that the defect is in fact covered by warranty, or reserve judgment until the subsystem or component is inspected by the Vendor's representative or is removed and examined at the Recipient Agencies property or at the Vendor's plant. At that time, the status of warranty coverage on the subsystem or component shall be mutually resolved between the Recipient Agency and the Vendor. Work necessary to affect the repairs defined in Section 5.10 of this Part shall commence within ten (10) working days after receipt of notification by the Vendor.

### **5.9.8 SCOPE OF WARRANTY REPAIRS**

When warranty repairs are required, the Recipient Agencies and the Vendor's representative shall agree within five (5) days after notification on the most appropriate course for the repairs and the exact scope of the repairs to be performed under the warranty. If no agreement is obtained within the five (5) day period, the Recipient Agencies reserves the right to commence the repairs in accordance with Section 5.10.

### **5.9.9 FLEET DEFECTS**

A fleet defect shall be defined as the failure of any identical items covered by the warranty and the specifications herein, and occurring in a twenty percent (20%) portion of the vehicles purchased under this contract.

The Vendor shall correct a fleet defect under the warranty provision. After correcting defect, the Vendor shall promptly undertake and complete a work program reasonably designed to prevent the occurrence of the same defect in all other vehicles purchased under this contract. The work program shall include inspection and/or correction of the potential or defective parts in all of the vehicles purchased under this contract. The warranty on items determined to be fleet defects shall be extended for the time and/or miles of the original warranty. This extended warranty shall begin on the date of the repair/replacement for the corrected item.

## **5.10 REPAIR PROCEDURES**

### **5.10.1 Repair Performance**

At its option, the Division, or its designated representative, may require the Vendor, or its designated representative, to perform warranty covered repairs that are clearly beyond the scope of Recipient Agencies capabilities. All warranty work done by Recipient Agencies personnel will be reimbursed by the Vendor.

### **5.10.2 Repairs by Vendor**

If the Recipient Agencies requires the Vendor to perform warranty covered repairs, the Vendor's representative must begin the work necessary to make repairs, within ten (10) working days after receiving notification of a defect from the Recipient Agencies. The Recipient Agencies shall make the vehicle available to complete repairs timely with the Vendor's repair schedule.

The Vendor will provide, at its own expense, all spare parts, tools and space required to complete repairs. At the Recipient Agencies option, the Vendor may be required to complete repairs. At the Recipient Agencies option, the Vendor may be

REQUEST FOR QUOTATION  
ADA Compliant Lowered Floor Minivans

---

required to remove the vehicle from Recipient Agency's property while repairs are being effected. If the vehicle is removed from Recipient Agency's property, repair procedures must be diligently pursued by the Vendor's representative.

**5.10.3 Repairs by Recipient Agencies**

a. **Parts Used**

If the Recipient Agency performs the warranty covered repairs, it shall correct or repair the defect and any related defects using Vendor specified spare parts available from its own stock or those supplied by the Vendor specifically for this repair. Monthly, or at a period to be mutually agreed upon, reports of all repairs covered by this warranty shall be submitted by the Recipient Agency to the Vendor for reimbursement or replacement of parts. The Vendor shall provide forms for these reports.

b. **Vendor Supplied Parts**

The Recipient Agency may request that the Vendor supply new parts for warranty covered repairs being performed by the Recipient Agency. These parts shall be shipped prepaid to the Recipient Agency from any source selected by the Vendor within 10 (ten) working days of receipt of the request for said parts.

c. **Defective Components Return**

The Vendor may request that parts covered by the warranty be returned to the manufacturing plant. The total cost for this action shall be paid by the Vendor. Materials should be returned in accordance with Vendor's instructions.

d. **Reimbursement for Labor**

The Recipient Agencies shall be reimbursed by the Vendor for labor. The amount shall be determined by multiplying the number of man-hours actually required to correct the defect by the current per hour, straight wage rate, plus 53 percent fringe benefits, plus the cost of towing in the vehicle if such action was necessary and if the vehicle was in the normal service area.

These wage and fringe benefit rates shall not exceed the rates in effect in the Recipient Agencies service garage at the time the defect correction is made.

REQUEST FOR QUOTATION  
ADA Compliant Lowered Floor Minivans

---

e. **Reimbursement for Parts**

The Recipient Agencies shall be reimbursed by the Vendor for defective parts and for parts that must be replaced to correct the defect. The reimbursement shall be at the invoice cost of the part(s) at the time of repair and shall include taxes where applicable and 10 percent handling costs.

**5.10.4 WARRANTY AFTER REPLACEMENT/REPAIRS**

If any component, unit, or subsystem is rebuilt or replaced by the Vendor or by the Recipient Agencies personnel, with the concurrence of the Vendor, the subsystem shall have the unexpired warranty period of the original subsystem.

**6 CONTRACT AWARD**

**6.1 Contract Award:** The Contract is intended to provide Agencies with a purchase price on all Contract Items. The Contract shall be awarded to the Vendor that provides the Contract Items meeting the required specifications for the lowest overall total cost as shown on the Pricing Pages.

**6.2** The Federal Transit Administration’s “Third Party Contracting Circular” (4220.1F), requires grantees (the DPT) to conduct procurements in a manner that prohibits the use of statutorily or administratively imposed In-State or local geographical preferences in the evaluation of bids or proposals, except in those cases where applicable Federal statutes expressly mandate or encourage geographic preference.

Therefore, the In-State vendor preference per West Virginia Code 5A-3-37 shall not apply to this procurement since it is partially or entirely funded with Federal Transit Administration funds.

**7. PRICING PAGE**

**7.1 Pricing Pages:** Vendor should complete Exhibit A Pricing Page by listing the unit price for each vehicle class, multiplying the unit price by the estimated quantity to arrive at an extended price, and then adding the extended prices for each Class to arrive at a total. All prices quoted are to be in whole dollars and include delivery charges.

**7.2** Exhibit A Pricing Page contains a list of the Contract Items and estimated purchase volume. The estimated purchase volume for each item represents the approximate volume of anticipated purchases only. No future use of the Contract or any individual item is guaranteed or implied.

**7.3** Vendor should electronically enter the information into the Pricing Pages through wvOASIS, if available, or as an electronic document.

REQUEST FOR QUOTATION  
ADA Compliant Lowered Floor Minivans

---

- 7.4** Additional agencies, as noted, could purchase from any awarded contract resulting from this bid. Specified deliverables would be as originally advertised, competed, evaluated and awarded.

**8. VENDOR QUALIFICATIONS**

The Vendor must be a person, firm or corporation that:

- a. Has in operation, a manufacturing plant adequate to assure delivery of all equipment within the time specified under the contract.
- b. Has adequate engineering and service personnel, or has the capability to have such personnel, to satisfy any engineering or service problems that may arise during the warranty period.
- c. Has similar vehicles in operation in comparable service for a minimum of one (1) year. The Vendor may be required to furnish a customer list indicating the number of units and dates in service during or equal period of during the bid evaluation period in addition to the requirements under Section 10.2 of these specifications.
- d. In lieu of this requirement, certified results of a shaker test may be requested by the Division during the or equal period to prove the proposed vehicles to be capable of operating the service contemplated for these vehicles.
- e. Has the necessary facilities and financial resources to complete the contract in a satisfactory manner within a required time. The Division shall have the right to conduct a pre-award survey of each Vendor.
- f. Has completed and accurate maintenance, parts, and operators' manuals.

**9. MISCELLANEOUS ITEMS TO BE SUPPLIED WITH BID**

- 9.1 Federal Transit Administration (FTA) Terms and Conditions and Certifications: Current FTA Terms and Conditions are included in this bid and must be met. Certifications for Vehicle Purchases, including Vehicle Pollution Requirements, Federal Motor Vehicle Safety Standards, Debarred Bidders, Disadvantaged Business Enterprise Manufacturers, Buy America Rolling Stock, Restrictions on Lobbying are provided on Bid Form Pages #1 - #10. All bid forms provided shall be properly completed and furnished by the Vendor as part of the bid. Failure to submit any of these forms shall disqualify the bid.
- 9.2 Pre-Award Review – The Vendor shall submit the following items and any further items if requested.

REQUEST FOR QUOTATION  
ADA Compliant Lowered Floor Minivans

---

- A. Complete mechanical description of vehicle, its construction and equipment including manufacturer's model name and/or number. Equipment to be described shall include the wheelchair lift, air conditioner, flip-up seat, and wheelchair securement system, if these items are specified herein.
- B. Proposed interior floor plans, showing detailed dimensions including the location of the wheelchair securement system and stanchions if specified.
- C. Curb weight (empty weight) and gross vehicle weight rating (GVWR) of vehicle.
- D. Samples or paint charts of available exterior paint colors and vinyl.
- E. Description of the warranties the Vendor proposes to furnish for the vehicle and for required ancillary equipment, including a listing of sites where warranty work will be performed.
- F. The location of the nearest depot which will furnish a complete supply of parts and components for the repair and maintenance of the vehicle to be supplied.
- G. Description of the undercoating/rustproofing system, including warranty to be provided.
- H. Identification of the specific location of the place of assembly in the case of a bus or the place of a conversion in the case of a converted van. If the location changes, the Vendor must notify the Division, in which case the Division reserves the right to perform an inspection similar to the pre-award inspection identified. If the results of the inspection are unsatisfactory, the Division may begin the contract termination process through the WV State Purchasing Division.

**9.3 Disadvantaged Business Enterprise (DBE)**

- A. All U.S. Department of Transportation, Federal Transit Administration (FTA) assisted contracts between FTA, the Division, and any Vendor shall include the following language:
  - 1) **Policy** – It is the policy of the U.S. Department of Transportation that Disadvantaged Business Enterprises (DBE) as defined in 49 CFR Part 26 that DBEs shall have the maximum opportunity to participate in the performance of contracts financed in whole or in part with federal funds under this agreement. Consequently, the DBE requirements of 49 CFR Part 26 apply to the agreement.
  - 2) **DBE Obligation** – The recipient or its Vendor agrees to ensure that DBEs as defined in 49 CFR Part 26 shall have the maximum opportunity to participate in the performance of contracts financed in whole or in part with federal funds under this agreement. Consequently, the DBE

REQUEST FOR QUOTATION  
ADA Compliant Lowered Floor Minivans

---

requirements of 49 CFR Part 26 apply to the agreement. In this regard, all recipients or Vendors shall take all necessary and reasonable steps in accordance with 49 CFR Part 26 to ensure that DBEs have the maximum opportunity to compete for and perform contracts.

Recipients and their Vendors shall not discriminate on the basis of race, color, national origin, or sex in the award and performance of U.S. Department of Transportation-assisted contracts.

- 3) The manufacturer of transit vehicles shall certify that it has complied with the requirements of 49 CFR Part 26 (March 4, 1999), Section 26.49, "Transit Vehicle Manufacturers". This certification shall be submitted with responses to this solicitation on **Bid Form #3**.
- 4) The Vendor shall make good faith efforts to replace a DBE subcontractor that is unable to perform, with another DBE subcontractor.
- 5) Where the Vendor is found to have failed to exert sufficient reasonable and good faith efforts to involve DBEs in the work provided, the Division may declare the Vendor noncompliant and in breach of contract.
- 6) The Vendor will keep records and documents for a reasonable time following performance of this contract to indicate compliance with the Division DBE Program. These records and documents will be made available at reasonable times and places for inspection by any authorized representative of the Division and will be submitted to the Division upon request.
- 7) The awarded Vendor agrees to include the following assurance in every subcontract it signs relevant to this contract: The Vendor and each Third Party Subcontractor must not discriminate on the basis of race, color, national origin, or sex in the award and performance of any FTA or U.S. DOT-assisted sub-agreement, third party contract, and third party subcontract, as applicable, and the administration of its DBE program or the requirements of 49 CFR Part 26.

The Vendor and each third party subcontractor must take all necessary and reasonable steps under 49 CFR Part 26 to ensure nondiscrimination in the award and administration of U.S. DOT-assisted sub-agreements, third party contracts and third party subcontracts, as applicable.

Failure by the Vendor and any of its third party contracts or third party subcontractors to carry out the requirements of this subparagraph 13.d(4)(b) is a material breach of this contract, and

REQUEST FOR QUOTATION  
ADA Compliant Lowered Floor Minivans

---

The following remedies, or such other remedy as the Division of Public Transit deems appropriate, include, but are not limited to, withholding payments; assessing sanctions; liquidated damages; and/or disqualifying the Vendor from future bidding as non-responsible.

**9.4 Prohibited Interest** – No employee, officer, board member, agent or their family members of the Division may participate in the selection, award or administration of a contract supported by Federal funds if a real or apparent conflict of interest is involved. Such a conflict could arise when any of the parties mentioned above have a financial or other interest in the Vendor selected for the contract.

**9.5 Civil Rights Requirements** – In connection with the execution of this contract, the following requirements will apply:

A. Nondiscrimination. In accordance with Title VI of the Civil Rights Act of 1964, As amended, 42 U.S.C. § 2000d, *et seq.*, Age Discrimination Act of 1975, as amended, 42 U.S.C. §6101, *et. seq.*, Americans With Disabilities Act of 1990, as amended, 42 U.S.C. § 12101, *et. seq.*, and Federal transit law at 49 U.S.C. §5332, as amended, the Vendor agrees that it will not discriminate against any employee or applicant for employment on the basis of race, color, religion, national origin, sex, age or disability. In addition, the Vendor agrees to comply with any other applicable Federal statutes that may be signed into law or regulations that may be promulgated.

B. Equal Employment Opportunity. The following equal employment opportunity requirements apply to the underlying contract:

1) Race, Color, Religion, National Origin, Sex, Disability, Age, Sexual Orientation, Gender Identity or Status as a Parent. In accordance with Title VI of the Civil Rights Act of 1964, as amended, 42 U.S.C. § 2000e, *et seq.*, and Federal transit laws at 49 U.S.C. § 5332, the Vendor agrees to comply with all applicable equal employment opportunity requirements of the U.S. Department of Labor (US DOL) regulations, “Office of Federal Contract Compliance Programs, Equal Employment Opportunity, Department of Labor,” 41 C.F.R. Parts 60 *et seq.*, (which implement Executive Order Number 11246, “Equal Employment Opportunity”, as amended by Executive Order Number 11375, “Amending Executive Order 11246 Relating to Equal Employment Opportunity,” 42 U.S.C. § 2000e note), and with any applicable Federal statutes, executive orders, regulations, and Federal policies that may in the future affect construction activities undertaken in the course of the Project. The Vendor agrees to take affirmative

REQUEST FOR QUOTATION  
ADA Compliant Lowered Floor Minivans

---

action to ensure that applicants are employed, and that employees are treated during their employment, without regard to their race, color, religion, national origin, sex, disability, age, sexual orientation, gender identity or status as a parent. Such action shall include, but not be limited to, the following: employment, upgrading, demotion or transfer, recruitment or recruitment advertising, layoff or termination; rates of pay or other forms or compensation; and selection for training, including apprenticeship. In addition, the Vendor agrees to comply with any implementing requirements FTA may issue.

- C. The Vendor also agrees to include these requirements in each subcontract financed in whole or in part with Federal assistance provided by FTA, modified only if necessary to identify the affected parties.

**9.6 Buy America Certification** – Vendor agrees to comply with 49 U.S.C. § 5323(j) and 49 CFR Part 661, which provides that Federal funds may not be obligated unless steel, iron, and manufactured products used in FTA-funded projects are produced in the United States, unless a waiver has been granted by FTA or the product is subject to a general waiver. General waivers are listed in 49 CFR 661.7 and include, microcomputer equipment, software, and small purchases (currently less than \$150,000) made with capital, operating, or planning funds. Separate requirements for rolling stock are set out at 49 CFR 661.11. Rolling stock not subject to a general waiver must be manufactured in the United States and have a 60 percent domestic content.

- A. A bidder must submit to the Division the appropriate Buy America certification on Bid Form #4 with all bids on FTA-funded contracts, except those subject to a general waiver. Per FTA requirements, bids that are not accompanied by a completed Buy America certification must be rejected as non-responsive. This requirement does not apply to lower tier subcontractors.
- B. Should the Vendor be declared responsive and low bid, pursuant to Pre-Award and Post Delivery Audit Requirements, the Division will require the Vendor to submit documentation (prior to any award) that lists:
- 1) Component and sub-component parts of the rolling stock to be purchased identified by manufacturer of the parts, their country of origin and costs; and
  - 2) The location of the final assembly point for the rolling stock, including a description of the activities that will take place at the final assembly point and the cost of final assembly.

REQUEST FOR QUOTATION  
ADA Compliant Lowered Floor Minivans

---

- 3) The Vendor shall submit one manufacturer's Federal Motor Vehicle Safety Standards (FMVSS) self-certification sticker providing information that the vehicle quoted complies with relevant FMVSS, or Manufacturer's certified statement that the contracted vehicles will not be subject to FMVSS regulations.
  - 4) Vendor shall submit evidence that it will be capable of meeting the bid specifications.
- C. As required by the Post Delivery Audit Requirement, any successful vendor will be required to furnish the following prior to any completed vehicle being placed into service or before any payment can be made:
- 1) Actual component and sub-component parts of the rolling stock provided, identified by manufacturer of the parts, their country of origin and costs; and
  - 2) Actual location of the final assembly point for the rolling stock provided, including a description of the activities that took place at the final assembly point and the actual cost of final assembly.

**9.7 Federal Regulation Changes** – Vendor shall at all times comply with all applicable FTA regulations, policies, procedures and directives, including without limitation those listed directly or by reference in the Master Agreement (FTA MA(22) dated October 1, 2015) <http://www.fta.dot.gov> between the WV Department of Transportation, Division and FTA, as they may be amended or promulgated from time to time during the term of this contract. Vendor's failure to so comply shall constitute a material breach of this contract.

**9.8 Debarment and Suspension** – This contract will comply with the requirements of 2 CFR Part 180, subpart C as adopted and supplemented by U.S. DOT regulations at 2 CFR Part 1200. Vendor is required to submit Bid Forms #6 & #7 with bid.

The Division will not enter into any arrangement to participate in the development or implementation of a contract with any Vendor that is debarred or suspended except as authorized by Executive Orders No. 12549, "Uniform Suspension, Debarment or Exclusion of Participant from Procurement or Non-procurement Activity," October 13, 1994, 31 U.S.C. § 6101 note, as amended by Executive Order No. 12689, "Debarment and Suspension," August 16, 1989, 31 U.S.C. § 6101 note, and other applicable federal laws, regulations, or guidance regarding participation with debarred or suspended Vendors.

The Division will review the U.S. GSA "System for Award Management – Lists of parties Excluded from Federal Procurement and Non-procurement Program," <https://www.sam.gov>,

REQUEST FOR QUOTATION  
ADA Compliant Lowered Floor Minivans

---

As required by U.S. DOT regulations, 2 CFR Part 1200. If the Vendor's name is on the list, the Division cannot enter into a contract with a Vendor on the debarred list.

Should an approved Vendor have subcontracts, it is required to include similar provisions in each subcontract and review the SAM at <https://www.sam.gov>, to determine that the subcontractor is not on the debarred or suspended list.

**9.9 Restrictions on Lobbying** – Every Vendor who applies or bids for an award of \$100,000 or more shall file the certification of **Bid Form #9** required by 49 CFR Part 20, “New Restrictions on Lobbying.” Each tier certifies to the tier above that it will not and has not used Federal appropriated funds to pay any person or organization for influencing or attempting to influence an officer or employee of any agency, a member of Congress, officer or employee of Congress, or an employee of a member of Congress in connection with obtaining any Federal contract, grant or any other award covered by 31 U.S.C. § 1352. Each tier shall also disclose the name of the registrant under the Lobbying Disclosure Act of 1995 who has made lobbying contacts on its behalf with non-Federal funds with respect to that Federal contract, grant or award covered by 31 U.S.C. §1352. Such disclosures are forwarded from tier to tier, up to the Division.

**9.10 Environmental Regulations** – The Vendor agrees it will not use any violating facilities, will report the use of facilities placed on or likely to be placed on the U.S. EPA “List of Violating Facilities,” will report violations of use of prohibited facilities to the Division who will in turn report each violation to FTA and the appropriate EPA Regional Office and will comply with the inspection and other requirements issued pursuant to the Environmental Protection Agency (EPA) regulations (40 CFR, Part 15), which prohibits the use under nonexempt federal contracts, grants, or loans of facilities included on the EPA list of violating facilities.

**9.11 Clean Air** – The Vendor agrees to comply with all applicable standards, orders, or regulations issued pursuant to the Clean Air Act, as amended, 42 U.S.C. § 7606 and other requirements of the Clean Air Act, as amended, 42 U.S.C. §§ 7401 – 7671q. The Vendor agrees to report each violation to the Division and understands and agrees that the Division will, in turn, report each violation as required to FTA and the appropriate EPA Regional Office.

The Vendor also agrees to include these requirements in each subcontract exceeding \$100,000 financed in whole or in part with Federal assistance by FTA.

**9.12 Clean Water** – The Vendor agrees to comply with all applicable standards, orders, or regulations issued pursuant to Section 508 of the Clean Water Act, as amended, 33 U.S.C. § 1368, and other provisions of the Clean Water Act, as amended, U.S.C. 33 §§1251 – 1377. The Vendor agrees to report each violation

REQUEST FOR QUOTATION  
ADA Compliant Lowered Floor Minivans

---

to the Division and understands and agrees that the Division will, in turn, report each violation as required to FTA and the appropriate EPA Regional Office.

The Vendor also agrees to include these requirements in each subcontract exceeding \$100,000 financed in whole or in part with Federal assistance provided by FTA.

- 9.13 Energy Conservation Requirements** – The Vendor agrees to comply with mandatory standards and policies relating to energy efficiency which are contained in the State Energy Conservation Plan issued in compliance with the Energy Policy and Conservation Act.
- 9.14 Contract Work Hours and Safety Standards Act** – The Vendor shall comply with Section 102 of the Contract Work Hours and Safety Standards Act (40 USC §§ 3701 *et seq.*, esp. § 3702) as supplemented by Department of Labor Regulations (29 CFR, § 5 & 29 CFR § 1926) as they involve the employment of mechanics and laborers.
- A. Overtime Requirements – No Vendor or subcontractor for any part of the contract work which may require or involve the employment of laborers or mechanics shall require or permit any such laborer or mechanic in any workweek in which he or she is employed on such work to work in excess of forty (40) hours in such workweek unless such laborer or mechanic receives compensation at a rate not less than one and one-half times the basic rate of pay for all hours worked in excess of forty (40) hours in such workweeks.
- B. Violation; Liability for Unpaid Wages; Liquidated Damages – In the event of any violation of the clause set forth in paragraph A of this section, the Vendor and any subcontractor responsible therefore shall be liable for the unpaid wages. In addition, such Vendor and subcontractor shall be liable to the United States for liquidated damages. Such liquidated damages shall be computed with respect to each individual laborer or mechanic, including watchmen and guards, employed in violation of the clause set forth in paragraph A of this section, in the sum of \$10 for each calendar day on which such individual was required or permitted to work in excess of the standard workweek of forty (40) hours without payment of the overtime wages required by the clause set forth in paragraph A of this section.
- C. Withholding for Unpaid Wages and Liquidated Damages – The Division shall upon its own action or upon written request of an authorized representative of the Department of Labor withhold or cause to be withheld, from any moneys payable on account of work performed by the Vendor or subcontractor under any such contract or any other Federal

REQUEST FOR QUOTATION  
ADA Compliant Lowered Floor Minivans

---

contract with the same prime Vendor, or any other federally-assisted contract subject to the Contract Work Hours and Safety Standards Act, which is held by the same prime Vendor, such sums as may be determined to be necessary to satisfy any liabilities of such Vendor or subcontractor for unpaid wages and liquidated damages as provided in the clause set forth in paragraph B of this section.

D. Subcontracts – The Vendor or subcontractor shall insert in any subcontracts the clauses set forth in this section and also a clause requiring the subcontractors to include these clauses in any lower tier subcontracts. The prime Vendor shall be responsible for compliance by any subcontractor or lower tier subcontractor with the clauses set forth in this section.

E. Payrolls and Basic Records – Payrolls and basic records relating thereto shall be maintained by the Vendor during the course of the work and preserved for a period of three (3) years thereafter for all laborers and mechanics working at the site of the work (or under the United States Housing Act of 1937, or under the Housing Act of 1949, in the construction or development of the project). Such records shall contain the name, address, and social security number of each such worker, his or her correct classification, hourly rates of wages paid (including rates of contributions or costs anticipated for bona fide fringe benefits or cash equivalents thereof of the types described in Section 1(b)(2)(B) of the Davis-Bacon Act), daily and weekly number of hours worked, deductions made and actual wages paid. Whenever the Secretary of Labor has found under 29 CFR .5(a)(1)(iv) that the wages of any laborer or mechanic include the amount of any costs reasonably anticipated in providing benefits under a plan or program described in Section 1(b)(2)(B) of the Davis-Bacon Act, the Vendor shall maintain records which show that the commitment to provide such benefits is enforceable, that the plan or program is financially responsible, and that the plan or program has been communicated in writing to the laborers or mechanics affected, and records which show the costs anticipated or the actual cost incurred in providing such benefits.

Vendors employing apprentices or trainees under approved programs shall maintain written evidence of the registration of apprenticeship programs and certification of the training programs, the registration of the apprentices and trainees, and the ratios and wage rates prescribed in the applicable programs.

**9.15 Hold Harmless** – The Vendor agrees to protect, defend, indemnify and hold the State of West Virginia, the Division, its officers, employees and agents free and harmless from and against any and all losses, penalties, damages, settlements, costs, charges, professional fees or other expenses or liabilities of every kind and

REQUEST FOR QUOTATION  
ADA Compliant Lowered Floor Minivans

---

character arising out of or relating to any and all claims, liens, demands, obligations, actions, proceedings or causes of action of every kind and character in connection with or arising directly or indirectly out of this Contract and/or the performance hereof. Without limiting the generality of the foregoing, and all such claims, etc., relating to personal injury, infringement of any patent, trademark, copyright (or application for any thereof) or of any other tangible or intangible personal or property right, or actual or alleged violation of any applicable statute, ordinance, administrative order, rule or regulation, or decrees of any court, shall be included in the indemnity hereunder. The Vendor further agrees to investigate, handle, respond to, provide defense for and defend any such claims, etc., at his/her sole expense and agrees to bear all other costs and expenses related thereto, even if such claim is groundless, false or fraudulent.

**9.16 Program Fraud and False or Fraudulent Statements and Related Acts**

The Vendor acknowledges that the provisions of the Program Fraud Civil Remedies Act of 1986, as amended 31 U.S.C. §§ 3801 *et seq.* and U.S. Department of Transportation regulations, “Program Fraud Civil Remedies,” 49 C.F.R. Part 31, apply to its actions pertaining to this Contract. Upon execution of the underlying contract, the Vendor certifies or affirms the truthfulness and accuracy of any statement it has made, it makes, it may make, or causes to be made, pertaining to the underlying contract or the FTA assisted project for which this Contract work is being performed. In addition to other penalties that may be applicable, the Vendor further acknowledges that if it makes, or causes to be made, a false, fictitious, or fraudulent claim, statement, submission, or certification, the Federal Government reserves the right to impose the penalties of the Program Fraud Civil Remedies Act of 1986 on the Vendor to the extent the Federal Government deems appropriate.

The Vendor also acknowledges that if it makes, or causes to be made, a false, fictitious, or fraudulent claim, statement, submission, or certification to the Federal Government under a contract connected with a project that is financed in whole or in part with Federal assistance originally awarded by FTA under the authority of 49 U.S.C. § 5307, the Government reserves the right to impose the penalties of 18 U.S.C. § 1001 and 49 U.S.C. § 5307(n)(1) on the Vendor, to the extent the Federal Government deems appropriate.

The Vendor agrees to include the above two clauses in each subcontract financed in whole or in part with Federal assistance provided by FTA. It is further agreed that the clauses shall not be modified, except to identify the subcontractor who will be subject to the provisions.

**9.17 Incorporation of FTA Terms**

The preceding provisions include, in part, certain Standard Terms and Conditions required by the U.S. Department of Transportation, whether or not expressly set

REQUEST FOR QUOTATION  
ADA Compliant Lowered Floor Minivans

---

forth in the preceding Contract provisions. All contractual provisions required by DOT, as set forth in FTA Circular 4220.1F, dated November 1, 2008, and are hereby incorporated by reference. Anything to the contrary herein notwithstanding, all FTA mandated terms shall be deemed to control in the event of a conflict with other provisions contained in this Contract. The Vendor shall not perform any act, fail to perform any act, or refuse to comply with any DPT requests which would cause DPT to be in violation of the FTA terms and conditions.

**9.18 Access to Records**

The Vendor agrees to permit DPT, the Secretary of the US DOT and the Comptroller General of the United States, or their authorized representatives, to inspect all Contract work, materials, payrolls and other data and records with regard to the Contract. The Vendor also agrees to permit an audit of the books, records, and accounts of the Vendor and its subcontractors.

**9.19 Accessibility**

Vendor agrees that any vehicles provided shall be in accordance with the 42 U.S.C. Sections 12101 *et seq.*, and US DOT regulations, "Transportation Services for Individuals with Disabilities Act (ADA)," 49 CFR Part 37; and Joint U.S. Architectural and Transportation Barriers Compliance Board (U.S. ATBCB) and U.S. DOT regulations, "Americans with Disabilities (ADA) Accessibility Specifications for Transportation Vehicles," 36 CFR Part 1192 and 49 CFR Part 38.

**9.20 Air Pollution and Fuel Economy**

Vendor is to ensure compliance with applicable Federal air pollution control and fuel economy regulations, such as EPA regulations, "Control of Air Pollution from Mobile Sources," 40 CFR Part 85; EPA regulations, "Control of Emissions from New and In-Use Vehicles," 40 CFR Part 86; and EPA regulations, "Fuel Economy and Greenhouse Gas Exhaust Emissions of Motor Vehicles" 40 CFR Part 600.

**9.21 Bid Protest Procedures**

Vendors have the option of protesting certain decisions made by the Purchasing Division. Please refer to the following link for Vendor Protest Procedures under Section 6.8.

<http://www.state.wv.us/admin/purchase/vrc/vpg/VendorProcurementGuide.pdf>

REQUEST FOR QUOTATION  
ADA Compliant Lowered Floor Minivans

---

**9.22 Appeals to the Federal Transit Administration (FTA)**

Under the Federal Transit Administration's Circular 4220.1F, the Federal Transit Administration's (FTA's) appeals process for reviewing protests of a recipient's procurement decisions are:

- 1) Requirements for the Protester – The protester must:
  - a) Qualify as an “Interested Party” – Only an “interested party” qualifies for FTA review of its appeal. An “interested party” is a party that is an actual or prospective bidder or offeror whose direct economic interest would be affected by the award or failure to award the contract at issue.
    - i) Subcontractors – A subcontractor does not qualify as an “interested party” because it does not have a direct economic interest in the results of the procurement.
    - ii) Consortia//Joint Ventures/Partnerships/Teams – An established consortium, joint venture, partnership, or team that is an actual bidder or offeror and is acting in its entirety, would qualify as an “interested party” because it has a direct economic interest in the results of the procurement. An individual member of a consortium, joint venture, partnership, or team, acting solely in its individual capacity, does not qualify as an “interested party” because it does not have a direct economic interest in the results of the procurement.
    - iii) Associations or Organizations – An association or organization that does not perform contracts does not qualify as an “interested party” because it does not have a direct economic interest in the results of the procurement.
  - b) Exhaust Administrative Remedies – The protester must exhaust its administrative remedies by pursuing the WV Purchasing Division protest procedures to completion before appealing their decision to FTA.
  - c) Appeal Within Five (5) Days – The protester must deliver its appeal to the FTA Regional Administrator, Region III, 1760 Market Street, Suite 500, Philadelphia, PA, 19103-4124 within five (5) working days of the date when the protester has received actual or constructive notice of the WV Purchasing Division's final decision. Likewise, the protester must provide its appeal to the same address within five (5) working days of the date when the protester has identified other grounds for appeal to FTA. For example, other grounds for appeal include the DPT's failure to have or failure to comply with the WV Purchasing Division's protest procedures or failure to review the protest.

REQUEST FOR QUOTATION  
ADA Compliant Lowered Floor Minivans

---

- 2) Extent of FTA Review – FTA limits its reviews of protests to:
- a) Failure of DPT to have or adhere to WV Purchasing Division written bid protest procedures, or failure of DPT to review a complaint or protest.
  - b) Alleged violations on other grounds are under the jurisdiction of the appropriate State or local administrative authorities.
  - c) Alleged violations of a specific Federal Law or regulation that provides an applicable complaint procedure shall be submitted and processed in accordance with that Federal Law or regulation. See, e.g., Buy America Requirements, 49 C.F.R. Part 661 (Section 661.15); Participation by Minority Business Enterprise in Department of Transportation Programs, 49 C.F.R. Section 26.89.

FTA will exercise discretionary jurisdiction over those appeals involving issues important to FTA’s overall public transportation program. FTA will refer violations of Federal law for which it does not have primary jurisdiction to the Federal authority having proper jurisdiction.

- 3) FTA Determinations to Decline Protest Reviews – FTA’s determination to decline jurisdiction over a protest does not mean that FTA approves of or agrees with WV Purchasing Division’s decision or that FTA has determined the contract is eligible for Federal participation. FTA’s determination means only that FTA does not consider the issues presented to be sufficiently important to FTA’s overall program that FTA considers a review to be required.

## **10. ORDERING AND PAYMENT TO VENDOR**

### **10.1 ORDERING:**

Vendor shall accept orders by regular mail, facsimile, e-mail, or any other written forms of communication.

### **10.2 Payment**

When submitting invoices for payment to the Division, the Vendor shall be required to provide an original typed invoice. The following items shall appear on the invoice:

- 1) Vendor’s Federal Employee Identification Number (FEIN)
- 2) Order number

REQUEST FOR QUOTATION  
ADA Compliant Lowered Floor Minivans

---

3) Invoice should reflect the base vehicle cost and any applicable options With unite cost. NOTE: Two invoices shall be submitted for each vehicle , one for 90% and one for 10%.

4) Submit all invoices to:  
Division of Multimodal Transportation Facilities-Public Transit  
Building 5, Room 663  
1900 Kanawha Blvd., East  
Charleston, West Virginia 25305

**10.2.1** Payment of 90% of the total cost shall be paid upon conditional acceptance of the vehicle(s).

**10.2.2** Conditional acceptance of the vehicle(s) by the Division shall be made upon completion of inspection by the Division of Public Transit under Section 17 of this RFQ.

**10.2.3** Under the conditional acceptance of the vehicle(s) provided, the Division of Public Transit shall retain 10% of the total cost per vehicle until all vehicles provided have been in actual service for thirty (30) days.

**10.2.4** In the event any vehicle is found to be unacceptable during the thirty (30) day period of conditional acceptance, the Division shall furnish to the Vendor, in writing, a letter of non- acceptance detailing any and all deficiencies.

**10.2.5** Final acceptance on each vehicle shall be made by the Division of Public Transit in writing upon completion of the period of conditional acceptance and/or after any and all deficiencies have been corrected.

**10.2.6** Final acceptance shall be made on each individual vehicle provided. (Some vehicles may be accepted, while acceptance of others remains pending.)

**10.2.7** Final acceptance of each vehicle shall be provided in writing by the Director of the Division or his/her authorized representative.

**10.2.8** All warranties as described in this contract shall begin with the first day after the date of final acceptance of each vehicle. **Vendor shall furnish Notification of Delayed Delivery Date of In-Transit Mileage Accumulation Forms for completion by the Division upon acceptance of the vehicle.**

**10.2.9** Prompt Payment – The prime Vendor agrees to pay each sub-contractor

REQUEST FOR QUOTATION  
ADA Compliant Lowered Floor Minivans

---

under this prime contract for satisfactory performance of its contract no later than fifteen (15) days from the receipt of each payment the prime Vendor receives from the Division. The Vendor agrees further to return retainage payments to each sub-contractor within fifteen (15) days after the sub-contractor's work is satisfactorily completed. Any delay of postponement of payment from the above referenced time frame may occur only for good cause following written approval from the Division. This clause applies to both DBE and non-DBE sub-contractors.

**11. DELIVERY AND RETURN:**

**11.1 Delivery Time and Location:** Vendors shall specify approximate delivery dates when submitting bids. Delivery of the vehicle shall be completed within 150 days after receipt of executed contract documents. Vendor shall ship all orders in accordance with the above schedule and shall not hold orders until a minimum delivery quantity is met.

**11.2 Late Delivery:** The Division must be notified in writing if delivery is delayed for any reason. The request for extension must be received by the Division no less than ten (10) days prior to the originally planned vehicle delivery date and must include detailed justification for the length of the time extension. Any delay in delivery that could cause harm to an Agency will be grounds for cancellation of the delayed order, and/or obtaining the items ordered from a third party.

Any Agency seeking to obtain items from a third party under this provision must first obtain approval of the Purchasing Division.

**11.3** Delivery shall be FOB destination to designated transit provider or:

Kanawha Valley Regional Transit Authority (KRT)  
1550 4<sup>th</sup> Avenue,  
Charleston, WV 25324

Vendor must contact KRT 24 hours before delivery at 304-343-7594. Delivery will be accepted Monday through Friday, between 9 a.m. and 2 p.m. exclusive of State holidays.

Any delay in delivery resulting from the common carriers operations, accidents, or mechanical failures in route shall be construed as a cause beyond the Vendor's control.

However, the Vendor shall have the responsibility of releasing the vehicle to the common carrier in time to reach the delivery site under normal delivery conditions.

**11.4** In case the delivery of the complete vehicle shall be necessarily delayed because of

REQUEST FOR QUOTATION  
ADA Compliant Lowered Floor Minivans

---

strike, Injunction, civil disturbance, government controls, or by reason of any cause or circumstances beyond the control of the Vendor, as detailed in writing by the Vendor, the term of completion of delivery shall be extended by a number of days to be determined in each instance by mutual agreement of the Division of Public Transit and Vendor.

- 11.5** If the vehicle is delivered over-the-road, a written report shall be submitted by the driver to the Division listing all incidents and unusual vehicle performance during the trip.

Should any service or repair be required during delivery, a comprehensive report shall be submitted to the Executive Director of the Division describing the nature of the service or repair and the cause.

- 11.6** Prior to acceptance, the Vendor shall have total risk of loss of the vehicle, including any damage sustained during the Vendor's driveway operation. Drivers shall keep a maintenance log enroute and it shall be delivered to the Division with the vehicle.

## **12. ACCEPTANCE TESTS**

### **12.1 Responsibility**

Fully-documented tests shall be conducted on each production vehicle following manufacture to determine its acceptance to the Division. These acceptance tests shall include pre-delivery inspections and testing by the Division after the vehicles have been delivered.

### **12.2 Pre-Delivery Tests**

The Vendor shall conduct acceptance tests at its plant on each vehicle following completion of manufacture and before delivery to the Division. These pre-delivery tests shall include visual and measured inspections, as well as testing the total vehicle operation. The tests shall be documented. Additional tests may be conducted at the Vendor's discretion to ensure that the completed vehicles have attained the desired quality and have met the requirements of Section 3: Specifications. This additional testing shall be recorded on appropriate test forms provided by the Vendor.

The pre-delivery tests will be scheduled and conducted with sufficient notice so that they may be witnessed by the resident inspectors, who may accept or reject the results of the tests. The results of pre-delivery tests, and any other tests, will be filed with the assembly inspection records for each vehicle. The under-floor equipment will be made available for inspection by the

REQUEST FOR QUOTATION  
ADA Compliant Lowered Floor Minivans

---

resident inspectors, using a hoist. A scaffold, or elevated platform will be provided by the Vendors to easily and safely inspect vehicle roofs. Delivery of each vehicle will require written authorization of a resident inspector. Authorization forms for the release of each vehicle for delivery will be provided by the Vendor. An executed copy of the authorization will accompany the delivery of each vehicle.

**12.3 Inspection - Visual and Measured**

Visual and measured inspections shall be conducted with the vehicle in a static condition. The purpose of the inspection testing is to verify overall dimensional and weight requirements, to verify that required components are included and are ready for operation, and to verify that components and subsystems that are designed to operate with the vehicle in a static condition do function as designed.

**13. Total Vehicle Operation**

Total vehicle operations shall be evaluated during road tests. The purpose of the road tests is to observe and verify the operation of the vehicle as a system and to verify the functional operation of the subsystem that can be operated only while the vehicle is in motion.

Each vehicle shall be driven for a minimum of 15 miles during the road tests. Observed defects shall be recorded on the test forms. The vehicle shall be retested when defects are corrected and adjustments are made. This process shall continue until defects or required adjustments are no longer detected. Results shall be pass/fail for these vehicle operation tests.

**14. Final Pre-Delivery Inspection:** Prior to delivery, all vehicles must be thoroughly inspected and serviced in compliance with the manufacturer's prescribed procedures which includes but is not limited to:

- a. Complete vehicle lubrication;
- b. Confirm oil level, fill crank case as needed, top off all fluids;
- c. Adjust engine to proper operating condition;
- d. Verify tire pressure and correct as necessary;
- e. Check front end alignment or four wheel alignment, perform alignment, and balance all tires;

REQUEST FOR QUOTATION  
ADA Compliant Lowered Floor Minivans

---

- f. Wash/Clean interior and exterior of vehicle. Remove all unnecessary tags, stickers (including window stickers), papers, tags, etc.
- g. Upon delivery, the vehicles fuel tanks shall be full of fuel;
- h. Affix a valid West Virginia Inspection Sticker to the windshield. The vehicle must be inspected in the month delivered.
- i. No dealer insignia or other advertising shall be affixed to the vehicle or appear on any accessory such as mud flaps, bumpers, deck lids, etc. Vehicles delivered with such advertising will be rejected;
- j. Perform operational checks which will cover all controls, systems, and devices, doors, windows, accessories, and road testing of the completed vehicle. Vehicle shall be driven at various speeds; brakes tested for dependability, vehicle checked for rattles, squeaks and must be in compliance with pre-delivery inspection/servicing procedures and make adjustments as necessary.

**15. Post-Delivery Tests** The Division shall, within fifteen (15) calendar days of notice from Vendor that vehicle is ready to be inspected for conditional acceptance, proceed with its inspection of vehicle for conditional acceptance. The Division will conduct acceptance tests on each delivered vehicle. The purpose of these tests is to identify defects that have become apparent between the time of vehicle release and delivery to the Division. The post-delivery tests shall include visual inspection and vehicle operations. The road tests for total vehicle operation are similar to those conducted at the Vendor's plant. Operational deficiencies of each vehicle shall be identified and recorded.

Vehicles that fail to pass the post-delivery tests are subject to non-acceptance. The Division shall record details of all defects and shall notify the Vendor of non-acceptance of each vehicle within 5 days after completion of the tests.

**16. Conditional Acceptance of Vehicle's** The vehicle shall undergo the Division's acceptance test. If the vehicle passes these tests, conditional acceptance of the vehicle by the Division occurs on the fifteenth day after delivery. Acceptance may occur earlier if the Division notifies the Vendor of early acceptance. If the vehicle fails these tests, it shall not be accepted until the repairs have been made.

**16.1 Repairs After Non-Acceptance**

The Division may require the Vendor, or its designated representative, to perform the repairs after non-acceptance or the work may be done by the Transit Authority or Recipient Agency's personnel with reimbursement by the Vendor.

REQUEST FOR QUOTATION  
ADA Compliant Lowered Floor Minivans

---

**17.1.1 Repairs by Vendor**

If the Transit Authority or Recipient Agency requires the Vendor to perform repairs after non-acceptance of the vehicle, Vendor's representative must begin work within five (5) working days after receiving notifications from the Division or Transit Authority of failure of acceptance tests. The Transit Authority or Recipient Agency shall make the vehicle available to complete repairs timely with the Vendor's repair schedule.

The Vendor shall provide, at its own expense, all spare parts, tools and space required to complete the repairs. At the Transit Authority or Recipient Agency's option, the Vendor may be required to remove the vehicle from their property. The repair procedure must be diligently pursued by the Vendor's representatives and the Vendor shall assume risk of loss while the vehicle is under its control.

**17.1.2 Repairs by Transit Authority or Recipient Agency**

- a) Parts Used. If the Transit Authority or Recipient Agency decides to perform the repairs after non-acceptance of the vehicle, it shall correct or repair the defect and any related defects using Vendor specified parts available from its own stock or those supplied by the Vendor specifically for this repair.

Monthly, or at a period to be mutually agreed upon, reports of all repairs covered by this procedure shall be submitted by the Transit Authority or Recipient Agency to the Vendor for reimbursement or replacement of parts. The Vendor shall provide forms for these reports.

- b) Vendor Supplied Parts. If the Vendor supplies parts for repairs being performed by the Transit Authority or Recipient Agency, after non-acceptance of the vehicle, these parts shall be shipped prepaid to the Transit Authority or Recipient Agency from any source selected by the Vendor within ten (10) working days after receipt of the request for said parts, provided said parts are available for shipment.
- c) Return of Defective Components. The Vendor may request that parts covered by this provision be returned to the manufacturing plant. The total cost for this action shall be paid by the Vendor.
- d) Reimbursement for Labor. The Transit Authority or Recipient Agency shall be reimbursed by the Vendor for labor. The amount shall be determined by multiplying the number of actual "man-hours" straight wage rate plus 53 percent fringe benefits, plus the cost of towing in the

REQUEST FOR QUOTATION  
ADA Compliant Lowered Floor Minivans

---

vehicle if such action was necessary. These wage and fringe benefit rates shall not exceed the rates in effect at the Transit Authority or Recipients Agency's service garage at the time the defect correction is made.

- e) Reimbursement for Parts. The Transit Authority or Recipient Agency shall be reimbursed by the Vendor for defective parts that must be replaced to correct the defect. The reimbursement shall include taxes where applicable and ten (10) percent handling cost.

**16.1.3 Delivery Payment/Risk of Loss:** Standard order delivery shall be F.O.B. destination to the Agency's designated location. Vendor shall include the cost of standard order delivery charges in its bid pricing/discount and is not permitted to charge the Agency separately for such delivery.

**17. VENDOR DEFAULT:**

**17.1** The Following shall be considered a vendor default under this Contract.

**18.1.1** Failure to provide Contract Items in accordance with the requirements contained herein.

**18.1.2** Failure to comply with other specifications and requirements contained herein.

**18.1.3** Failure to comply with any laws, rules, and ordinances applicable to the Contract Services provided under this Contract.

**18.1.4** Failure to remedy deficient performance upon request.

**17.2** The Following remedies shall be available to Agency upon default.

**18.2.1** Immediate cancellation of the Contract.

**18.2.2** Immediate cancellation of one or more release orders issued under this Contract.

- i. Any other remedies available in law or equity.

REQUEST FOR QUOTATION  
ADA Compliant Lowered Floor Minivans

---

**18. MISCELLANEOUS:**

- 18.1 No Substitutions:** Vendor shall supply only Vehicles as submitted in response to the Solicitation unless a contract modification is approved in accordance with the provisions contained in this Contract.
- 18.2 Vendor Supply:** Vendor must carry sufficient inventory of the Contract Items being offered to fulfill its obligations under this Contract. By signing its bid, Vendor certifies that it can supply the Contract Items contained in its bid response.
- 18.3 Contract Manager:** During its performance of this Contract, Vendor must designate and maintain a primary contract manager responsible for overseeing Vendor's responsibilities under this Contract. The Contract manager must be available during normal business hours to address any customer service or other issues related to this Contract. Vendor should list its Contract manager and his or her contact information below.

**Contract Manager:** Blair Taseff

**Telephone Number:** 440-653-0193

**Fax Number:** 419-836-8460

**Email Address:** btaseff@tescobus.com

**18.4 NOTIFICATION OF FEDERAL PARTICIPATION**

Federal funding for this project is being provided by the Federal Transit Administration through various CFDA grants for 80% of the project cost. CFDA grants will be specified after award.

REQUEST FOR QUOTATION  
ADA Compliant Lowered Floor Minivans

19. PROPOSED FLOOR PLANS

MINI VAN  
SEATING CAPACITY  
WITH ONE  
WHEELCHAIR SPACE

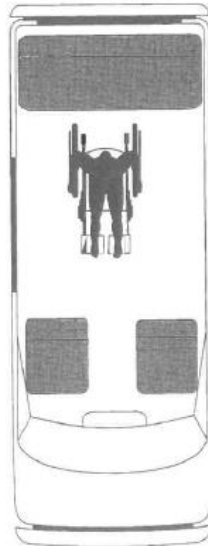

TWO SEATER FLIP  
DOWN SEAT BEHIND  
DRIVER

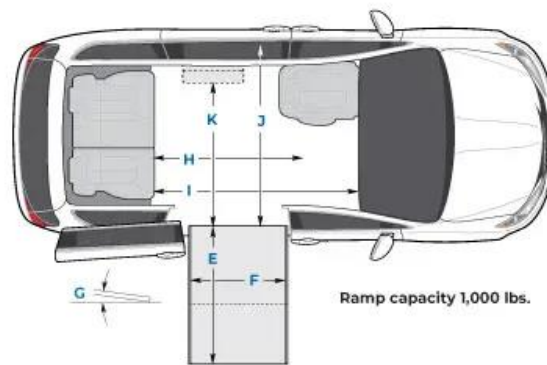

Ramp capacity 1,000 lbs.

REQUEST FOR QUOTATION  
ADA Compliant Lowered Floor Minivans

---

**20. REQUIRED BID FORMS**

The following certifications must be properly **completed and furnished by the bidder as part of the bid**. Failure to submit any of these certifications **shall deem the bid non-responsive**.

*A required documentation checklist has been provided for bidder's usage.*

REQUEST FOR QUOTATION  
ADA Compliant Lowered Floor Minivans

---

**BID FORM #1**

**REQUIRED BID FORM TO BE SUBMITTED WITH BID**

Location(s) of the Technical Service Representative(s) and parts distribution center(s) closest or in the State of West Virginia.

**Location(s) of the technical service representative(s).**

**Name:** \_\_\_\_ See attached list of West Virginia service facilities \_\_\_\_\_

**Address:** \_\_\_\_\_

\_\_\_\_\_

**Telephone:** \_\_\_\_\_

**Name:** \_\_\_\_\_

**Address:** \_\_\_\_\_

\_\_\_\_\_

**Telephone:** \_\_\_\_\_

**Location(s) of parts distribution center(s).**

**Name:** Chassis parts are available from any RAM dealer.  
See attached list of dealers in West Virginia  
In addition, body and specialized parts are available from TESCO.

**Address:** \_\_\_\_ 6401 Seaman Rd, Oregon OH 43616 \_\_\_\_\_

\_\_\_\_\_

**Telephone:** \_\_\_\_ 419-836-2835 \_\_\_\_\_

REQUEST FOR QUOTATION  
ADA Compliant Lowered Floor Minivans

---

**BID FORM #2**

**CERTIFICATION FOR AIR & WATER POLLUTION  
REQUIRED BID FOR TO BE SUBMITTED WITH BID**

The Vendor certifies that the vehicles proposed:

**ARE X** in compliance with the regulations in 40 CFR Part 85, 40 CFR Part 86, 40 CFR Part 600, Clean Water Act and the air/water pollution criteria established by the Environmental Protection Agency of the United States Government.

**ARE NOT** \_\_\_\_\_ in compliance with the regulations in 40 CFR Part 85, 40 CFR Part 86, 40 CFR Part 600, Clean Water Act and the air/water pollution criteria established by the Environmental Protection Agency of the United States Government.

\_\_\_\_\_ 5/21/2024 \_\_\_\_\_

Date

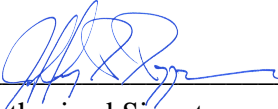
  
\_\_\_\_\_

Authorized Signature

\_\_\_\_\_ Vice-President \_\_\_\_\_

Title

\_\_\_\_\_ Transportation Equipment Sales Corporation \_\_\_\_\_  
Company Name

---

**BID FORM #3**

**DISADVANTAGED BUSINESS ENTERPRISE  
VENDORS/ MANUFACTURERS CERTIFICATION**

**REQUIRED BID FOR TO BE SUBMITTED WITH BID**

**(Check appropriate statement)**

\_\_\_\_\_ The Vendor, if a transit vehicle manufacturer, hereby certifies that it has complied with the requirements of 49 CFR Section 26.49 by submitting an annual DBE goal to the Federal Transit Administration (FTA). The goal has either been approved or not disapproved by FTA.

X The Vendor, if a non-manufacturing supplier, hereby certifies that the manufacturer of the transit vehicle to be supplied has complied with the above-referenced requirement of 49 CFR Section 26.49.

5/21/2024 \_\_\_\_\_

Date

  
\_\_\_\_\_

Authorized Signature

Vice-President \_\_\_\_\_

Title

Transportation Equipment Sales Corporation \_\_\_\_\_

Company Name

REQUEST FOR QUOTATION  
ADA Compliant Lowered Floor Minivans

---

**BID FORM #4**

**BUY AMERICA CERTIFICATION  
ROLLING STOCK  
REQUIRED BID FOR TO BE SUBMITTED WITH BID**

**Certificate of Compliance**

The bidder or offeror hereby certifies that it will comply with the requirements of section 165(b) (3), of the Surface Transportation Assistance Act of 1982, as amended, and the applicable regulations of 49 CFR 661.11:

\_\_\_5/21/2024\_\_\_\_\_

Date



\_\_\_\_\_  
Authorized Signature

\_\_\_ Transportation Equipment Sales Corporation \_\_\_\_\_

Company Name

\_\_\_ Jeff Pappas \_\_\_\_\_

Name

\_\_\_ Vice-President \_\_\_\_\_

Title

**Certificate for Non-Compliance**

The bidder or offeror hereby certifies that it cannot comply with the requirements of section 165(b) (3) of the Surface Transportation Assistance Act of 1982, as amended, but may qualify for an exception to the requirement consistent with section 165(b) (2) or (b) (4) of the Surface Transportation Assistance Act, as amended, and the applicable regulations in 49 CFR 661.7.

\_\_\_\_\_  
Date

\_\_\_\_\_  
Authorized Signature

\_\_\_\_\_  
Company Name

\_\_\_\_\_  
Name

\_\_\_\_\_  
Title

REQUEST FOR QUOTATION  
ADA Compliant Lowered Floor Minivans

---

**BID FORM #5**

**FEDERAL MOTOR VEHICLE  
SAFETY STANDARDS CERTIFICATION**

**REQUIRED BID FORM TO BE SUBMITTED WITH BID**

The vendor hereby certifies that it shall submit, as required by Title 49 of the CFR, Part 663 - Subpart D, it's self-certification information stating that the vehicle(s) will comply with the relevant Federal Motor Vehicle Safety Standards issued by the National Highway Traffic Safety Administration in Title 49 of the Code of Federal Regulations, Part 571.

5/21/2024 \_\_\_\_\_

Date

 \_\_\_\_\_

Authorized Signature

\_\_\_\_ Vice-President \_\_\_\_\_

Title

\_\_\_\_ Transportation Equipment Sales Corporation \_\_\_\_\_

Company Name

REQUEST FOR QUOTATION  
ADA Compliant Lowered Floor Minivans

---

**BID FORM #6**  
**U.S. Comptroller's Debarment List Certification**  
**REQUIRED BID FOR TO BE SUBMITTED WITH BID**

Transportation Equipment Sales Corporation \_\_\_\_\_ hereby certifies that it

**IS or**

**IS NOT** (specify one) included on the U.S. GSA's debarment and suspension information available at <https://www.sam.gov>.

5/21/2024 \_\_\_\_\_

Date

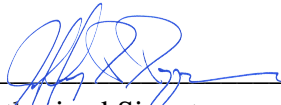
  
\_\_\_\_\_

Authorized Signature

Vice-President \_\_\_\_\_

Title

Transportation Equipment Sales Corporation \_\_\_\_\_

Company Name

REQUEST FOR QUOTATION  
ADA Compliant Lowered Floor Minivans

---

**BID FORM #7**

**REQUIRED BID FOR TO BE SUBMITTED WITH BID**

**CERTIFICATION OF PRIMARY PARTICIPANT REGARDING  
DEBARMENT, SUSPENSION, AND OTHER RESPONSIBILITY MATTERS**

The Primary Participant (applicant for an FTA grant or cooperative agreement, or potential contractor for a major third party contract),

\_ Transportation Equipment Sales Corporation \_\_\_\_ (COMPANY NAME) certifies to the best of its knowledge and belief, that it and its principals:

1. Are not presently debarred, suspended, proposed for debarment, declared ineligible, or voluntarily excluded from covered transactions by any Federal department or agency;
2. Have not within a three-year period preceding this proposal been convicted of or had a civil judgment rendered against them for commission of fraud or a criminal offense in connection with obtaining, attempting to obtain, or performing a public (Federal, State or local) transaction or contract under a public transaction; violation of Federal or State antitrust statutes or commission of embezzlement, theft, forgery, bribery, falsification or destruction of records, making false statements, or receiving stolen property.
3. Are not presently indicted for or otherwise criminally or civilly charged by a governmental entity (Federal, State or local) with commission of any of the offenses enumerated in paragraph (2) of this certification; and
4. Have not within a three-year period preceding this application/proposal had one or more public transactions (Federal, State or local) terminated for cause or default.

If the primary participant (applicant for an FTA grant, or cooperative agreement, or potential third party contractor) is unable to certify to any of the statements in this certification, the participant shall attach an explanation to this certification.)

THE PRIMARY PARTICIPANT (APPLICANT FOR AN FTA GRANT OR COOPERATIVE AGREEMENT, OR POTENTIAL CONTRACTOR FOR A MAJOR THIRD PARTY CONTRACT),  
\_\_\_\_ Transportation Equipment Sales Corporation \_\_\_\_\_, CERTIFIES OR AFFIRMS THE TRUTHFULNESS AND ACCURACY OF THE CONTENTS OF THE STATEMENTS SUBMITTED ON OR WITH THIS CERTIFICATION AND UNDERSTANDS THAT THE PROVISIONS OF 31 U.S.C. SECTIONS 3801 ET SEQ. ARE APPLICABLE THERETO.

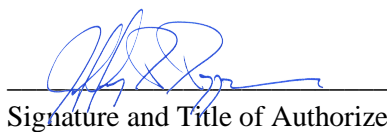
 Vice-President, Transportation Equipment Sales Corporation  
Signature and Title of Authorized Official

REQUEST FOR QUOTATION  
ADA Compliant Lowered Floor Mini-Van

---

**BID FORM #8**  
REQUIRED BID FOR TO BE SUBMITTED WITH BID

***VENDOR'S CERTIFICATION OF  
UNDERSTANDING AND ACCEPTANCE***

The Vendor hereby certifies that all Technical Specifications and Contract Terms and Conditions have been carefully reviewed, are fully understood and shall be adhered to in performance and completion of any contract resulting from this bid.

5/21/2024 \_\_\_\_\_

Date

  
\_\_\_\_\_

Authorized Signature

Vice-President \_\_\_\_\_

Title

Transportation Equipment Sales Corporation \_\_\_\_\_

Company Name

**SPECIFICATION COMPLIANCE**

NOTE: Please check if what is offered is in exact compliance with specifications. **Any discrepancies must be listed as an attachment to the bid proposal. Exact dimensions and/or descriptions must be provided as a part of the Vendor's bid proposal when submitted.**

Bid proposal submitted meets and/or exceeds all specification requirements.

Bid proposal submitted contains deviations from specification requirements. Detailed descriptions of these deviations have been provided with this bid proposal.

REQUEST FOR QUOTATION  
ADA Compliant Lowered Floor Mini-Van

---

**BID FORM #9**  
**REQUIRED BID FOR TO BE SUBMITTED WITH BID**

**CERTIFICATION OF RESTRICTIONS ON LOBBYING**

The undersigned (Vendor, Contractor) certifies, to the best of his or her knowledge and belief, that:

1. No Federal appropriated funds have been paid or will be paid by or on behalf of the undersigned, to any person for influence or attempt to influence an officer or employee of any Federal agency, a Member of Congress, an officer or employee of Congress, or an employee of a Member of Congress regarding the award of a Federal grant, loan (including a line of credit), cooperative agreement, loan guarantee, or loan insurance, or the extension, continuation, renewal, amendment, or modification of any Federal grant, loan (including a line of credit), cooperative agreement, loan guarantee, or loan insurance.
2. If any funds other than Federal appropriated funds have been or will be paid to any person to influence or attempt to influence an officer or employee of any Federal agency, a Member of Congress, an officer or employee of Congress, or any employee of a Member of Congress in connection with any application for a Federal grant, loan (including a line of credit), cooperative agreement, loan guarantee, or loan insurance, the undersigned assures that it will complete and submit Standard Form-LLL, "Disclosure of Lobbying Activities," Rev. 7-97; and
3. The undersigned understands that the language of this certification shall be included in the award documents for all sub awards at all tiers (including subcontracts, sub grants, sub agreements. and contracts under grants, loans (including a line of credit), cooperative agreements, loan guarantees, and loan insurance.

Undersigned understands that this certification is a material representation of fact upon which reliance is placed by the Federal government and that submission of this certification is a prerequisite for providing a Federal grant, loan (including a line of credit), cooperative agreement, loan guarantee, or loan insurance for a transaction covered by 31 U.S.C. 1352. The undersigned also understands that any person who fails to file a required certification shall be subject to a civil penalty of not less than \$10,000 and not more than \$100,000 for each such failure.

The (Vendor, Contractor) Transportation Equipment Sales Corporation, certifies or affirms the truthfulness and accuracy of each statement of its certification and disclosure, if any. In addition, the (Vendor, Contractor) understands and agrees that the provisions of 31 U.S.C. §§ 3801, et seq., apply to this certification and disclosure.

5/21/2024 \_\_\_\_\_  
Date Authorized Signature

\_\_\_\_ Vice-President \_\_\_\_\_  
Title

REQUEST FOR QUOTATION  
ADA Compliant Lowered Floor Mini-Van

---

**BID FORM #10**

**REQUIRED BID DOCUMENTATION CHECKLIST**

Model Year: 2024    Model: Chrysler Pacifica with FR Conversions Wheelchair Accessibility  
Upfit

**Mandatory Bid Forms – must be submitted with bid:**

Bid Form #1: Locations of Technical Service Representatives and Parts Distribution Centers

Bid Form #2: Certification for Air & Water Pollution

Bid Form #3: Disadvantaged Business Enterprise Vendors/Manufacturers Certification

Bid Form #4: Buy America Certification Rolling Stock

Bid Form #5: Federal Motor Vehicle Safety Standards Certification

Bid Form #6: U.S. Comptroller's Debarment List Certification

Bid Form #7: Certification of Primary Participant Regarding  
Debarment, Suspension, and Other Responsibility Matters

Bid Form #8: Vendor's Certification of Understanding and Acceptance

Bid Form #9: Certification of Restrictions on Lobbying

Exhibit A Pricing Page

REQUEST FOR QUOTATION  
ADA Compliant Lowered Floor Mini-Van

---

**Documentation – to be submitted with bid:**

**Referenced**

- 3.3.1.1 Engine: provide product description, warranty information and product literature.
- 3.6.1 Transmission: provide product description, warranty information and product literature.
- 3.6.4 Back Up Camera System: provide product description, warranty information and product literature.
- 3.11 Tires: provide product description, warranty information and product literature.
- 3.14.4 Undercoating and Rustproofing: provide product description, warranty information and literature.
- 3.14.7 Ambulatory Passenger Entrance/Exit: provide location, size, door operating details.
- 3.19.2 Floor Covering: provide samples of floor covering and colors to be provided.
- 3.22 Seating: provide product description, warranty information, product literature and color charts for all of the seating products to be utilized. Proposed floor plan.
- 3.2201 Driver’s Seat: provide description of product.
- 3.27 Wheelchair Securement System: provide product description, warranty information and product literature.
- 3.28 Wheelchair Occupant Restraint System: provide product description, warranty information and product literature.
- 3.29 Wheelchair Ramp: provide Make, Model #, product description, warranty information and product literature.
- 3.35 Training: submit letter of understanding to the terms in this Section.

**REQUEST FOR QUOTATION**  
**ADA Compliant Lowered Floor Mini-Van**

---

- 3.31.5 Security Camera: provide product description, warranty information and product literature.
- 5.9.1 Warranty on complete vehicle.
- 5.9.2 Warranty on Basic Vehicle Structure.
- 5.9.4 Warranty: warranties to be provided on subsystems and components.
- 10.2 A. Complete mechanical description of vehicle, its construction and equipment including manufacturer's model name and /or number. Include description of front and rear air conditioning and heat systems.
- 10.2 B Proposed interior floor plans, showing detailed dimensions including the location of the wheelchair securement system and stanchions.
- 10.2 C. Curb weight (empty weight) and gross vehicle weight rating (GVWR) of vehicle.
- 10.2 H. Identification of the conversion location of the van.
- 10.2 I. A list of five (5) users names, addresses, emails and telephone numbers who have been provided similar equipment by the Vendor.
- No Debt Affidavit
- Addendum Acknowledgement

REQUEST FOR QUOTATION  
**ADA Compliant Lowered Floor Mini-Van**

---

List of Suggested Vendors

Bus Service Inc.  
3153 Lamb Avenue  
Columbus, OH 43219

Central States Bus Sales, Inc.  
361 United Court  
Lexington, KY 40509

Midwest Transit Kankakee  
146 Issert Drive  
Kankakee, IL 60901

Mobil 1  
2100 Washington Rd.  
Canonsburg, PA 15317

Rohrer Bus Sales  
1515 State Road  
PO Box 100  
Duncannon, PA 17020

Sonny Merryman Inc.  
PO Box 495  
Rustburg, VA 24588

Transportation Equipment Sales  
P. O. Box 167230  
Oregon, OH 43616

REQUEST FOR QUOTATION  
ADA Compliant Lowered Floor Mini-Van

---

**Appendix A: Frequently Asked Questions from Vendors**

**CRFQ 0810**

**Vendor Questions / Agency Responses:**

**\*Please note that all of these questions may not pertain to the updated specifications of this current bid. If there are additional questions, please provide them and we will respond to the inquiries as soon as possible in order to complete the bidding process.**

REQUEST FOR QUOTATION  
ADA Compliant Lowered Floor Mini-Van

---

**Appendix B: Federal Clauses**

**FEDERAL CLAUSES**

(where applicable)

**1. No Government Obligation to Third Parties**

- a. MOVTA and CONTRACTOR acknowledge and agree that, notwithstanding any concurrence by the Federal Government in or approval of the solicitation or award of the underlying contract, absent the express written consent by the Federal Government, the Federal Government is not a party to this contract and shall not be subject to any obligations or liabilities to MOVTA, CONTRACTOR, or any other party (whether or not a party to that contract) pertaining to any matter resulting from the underlying contract.
- b. The CONTRACTOR agrees to include the above clause in each subcontract financed in whole or in part with Federal assistance provided by FTA. It is further agreed that the clause shall not be modified, except to identify the SUBCONTRACTOR who will be subject to its provisions.

**2. Program Fraud and False or Fraudulent Statements or Related Acts.**

- a. The CONTRACTOR acknowledges that the provisions of the Program Fraud Civil Remedies Act of 1986, as amended, 31 U.S.C. § 3801 et seq. and U.S. DOT regulations, "Program Fraud Civil Remedies," 49 C.F.R. Part 31, apply to its actions pertaining to this Project. Upon execution of the underlying contract, the CONTRACTOR certifies or affirms the truthfulness and accuracy of any statement it has made, it makes, it may make, or causes to be made, pertaining to the underlying contract or the FTA assisted project for which this contract work is being performed. In addition to other penalties that may be applicable, the CONTRACTOR further acknowledges that if it makes, or causes to be made, a false, fictitious, or fraudulent claim, statement, submission, or certification, the Federal Government reserves the right to impose the penalties of the Program Fraud Civil Remedies Act of 1986 on the CONTRACTOR to the extent the Federal Government deems appropriate.
- b. The CONTRACTOR also acknowledges that if it makes, or causes to be made, a false, fictitious, or fraudulent claim, statement, submission, or certification to the Federal Government under a contract connected with a project that is financed in whole or in part with Federal assistance originally awarded by FTA under the authority of 49 U.S.C. Chapter 53, the Government reserves the right to impose the penalties of 18 U.S.C. § 1001 and 49 U.S.C. § 5323(l) or other applicable federal law on the CONTRACTOR, to the extent the Federal Government deems appropriate.
- c. The CONTRACTOR agrees to include the above two clauses in each subcontract financed in whole or in part with Federal assistance provided by FTA. It is further agreed that the clauses shall not be modified, except to identify the SUBCONTRACTOR who will be subject to the provisions.

**3. Access to Records**

The CONTRACTOR agrees to provide MOVTA, the FTA Administrator, the Comptroller General of the United States or any of their authorized representatives access to any books, documents, papers and records of the CONTRACTOR which are directly pertinent to this contract for the purposes of making audits, examinations, excerpts and transcriptions. The CONTRACTOR agrees to permit any of the foregoing parties to reproduce by any means whatsoever or to copy excerpts and transcriptions as

**REQUEST FOR QUOTATION**  
**ADA Compliant Lowered Floor Mini-Van**

---

reasonably needed. In accordance with 2 CFR 200.333, the CONTRACTOR agrees to maintain all books, records, accounts and reports required under this contract for a period of not less than three years after the date of termination or expiration of this contract except in the event of litigation or settlement of claims arising from the performance of this Contract, in which case records shall be maintained until the disposition of all such litigation, appeals, claims or exceptions related thereto.

**4. Federal Changes**

The CONTRACTOR shall at all times comply with all applicable FTA regulations, policies, procedures and directives, including without limitation those listed directly or by reference in the Department of Transportation, Federal Transit Administration, Master Agreement between Purchaser and FTA, as they may be amended or promulgated from time to time during the term of this contract. The CONTRACTOR's failure to comply shall constitute a material breach of this contract.

**5. Civil Rights**

The following requirements apply to the underlying contract:

a. Nondiscrimination - In accordance with Title VI of the Civil Rights Act, as amended, 42 U.S.C. § 2000d, section 303 of the Age Discrimination Act of 1975, as amended, 42 U.S.C. § 6102, section 202 of the Americans with Disabilities Act of 1990, 42 U.S.C. § 12132, and Federal transit law at 49 U.S.C. § 5332, the CONTRACTOR agrees that it will not discriminate against any employee or applicant for employment because of race, color, creed, national origin, sex, age, or disability. In addition, the CONTRACTOR agrees to comply with applicable Federal implementing regulations and other implementing requirements FTA may issue.

b. Equal Employment Opportunity - The following equal employment opportunity requirements apply to the underlying contract:

(i) Race, Color, Creed, National Origin, Sex - In accordance with Title VII of the Civil Rights Act, as amended, 42 U.S.C. § 2000e, and Federal transit laws at 49 U.S.C. § 5332, the CONTRACTOR agrees to comply with all applicable equal employment opportunity requirements of U.S. Department of Labor (U.S. DOL) regulations, "Office of Federal Contract Compliance Programs, Equal Employment Opportunity, Department of Labor," 41 C.F.R. Parts 60 et seq., (which implement Executive Order No. 11246, "Equal Employment Opportunity," as amended by Executive Order No. 11375, "Amending Executive Order 11246 Relating to Equal Employment Opportunity," 42 U.S.C. § 2000e note), and with any applicable Federal statutes, executive orders, regulations, and Federal policies that may in the future affect construction activities undertaken in the course of the Project. The CONTRACTOR agrees to take affirmative action to ensure that applicants are employed, and that employees are treated during employment, without regard to their race, color, creed, national origin, sex, or age. Such action shall include, but not be limited to, the following: employment, upgrading, demotion or transfer, recruitment or recruitment advertising, layoff or termination; rates of pay or other forms of compensation; and selection for training, including apprenticeship. In addition, the CONTRACTOR agrees to comply with any implementing requirements FTA may issue.

(ii) Age - In accordance with section 4 of the Age Discrimination in Employment Act of 1967, as amended, 29 U.S.C. § 623 and Federal transit law at 49 U.S.C. § 5332, the CONTRACTOR agrees to

**REQUEST FOR QUOTATION**  
**ADA Compliant Lowered Floor Mini-Van**

---

refrain from discrimination against present and prospective age. In addition, the CONTRACTOR agrees to comply with any implementing requirements FTA may issue.

(iii) Disabilities - In accordance with section 102 of the Americans with Disabilities Act, as amended, 42 U.S.C. § 12112, the CONTRACTOR agrees that it will comply with the requirements of U.S. Equal Employment Opportunity Commission, "Regulations to Implement the Equal Employment Provisions of the Americans with Disabilities Act," 29 C.F.R. Part 1630, pertaining to employment of persons with disabilities. In addition, the CONTRACTOR agrees to comply with any implementing requirements FTA may issue.

c. The CONTRACTOR also agrees to include these requirements in each subcontract financed in whole or in part with Federal assistance provided by FTA, modified only if necessary to identify the affected parties.

**6. Disadvantaged Business Enterprises**

a. It is the policy of the Department of Transportation and MOVTA that Disadvantaged Business Enterprises (DBEs) as defined in 49 C.F.R. part 26 shall have the maximum opportunity to participate in the performance of contracts financed in whole or part with federal funds under this contract.

Consequently, the DBE requirement of 49 C.F.R. applies to this contract.

b. The CONTRACTOR or subcontractor shall not discriminate on the basis of race, color, natural origin, or sex in the performance of this contract. The CONTRACTOR shall carry out applicable requirements of 49 C.F.R. Part 26 in the award and administration of DOT assisted contracts. Failure by the contractor to carry out these requirements is a material breach of this contract, which may result in the termination of this contract or such other remedy as the recipient deems appropriate.

c. DBEs will be encouraged and afforded full opportunity to actively solicit information concerning this project and to submit bids and or proposals.

**7. Incorporation of FTA Terms**

The preceding provisions include, in part, certain Standard Terms and Conditions required by U.S. DOT, whether or not expressly set forth in the preceding contract provisions. All contractual provisions required by U.S. DOT, as set forth in FTA Circular 4220, 2 CFR 200.318, and subsequent revisions are hereby incorporated by reference. Anything to the contrary herein notwithstanding, all FTA-mandated terms shall be deemed to control in the event of a conflict with other provisions contained in this Agreement. The CONTRACTOR shall not perform any act, fail to perform any act, or refuse to comply with any MOVTA request, which would cause MOVTA to be in violation of the FTA terms and conditions.

**8. Energy Conservation**

The CONTRACTOR agrees to comply with mandatory standards and policies relating to energy efficiency which are contained in the state energy conservation plan issued in compliance with the Energy Policy and Conservation Act, 42 U.S.C. §§ 6321 *et seq.*

**9. Termination**

a. Termination for Convenience: MOVTA may terminate this contract, in whole or in part, at any time by written notice to the CONTRACTOR. The CONTRACTOR shall be paid its costs, including contract

**REQUEST FOR QUOTATION**  
**ADA Compliant Lowered Floor Mini-Van**

---

closeout costs, and profit on work performed up to the time of termination. The CONTRACTOR shall promptly submit its termination claim to MOVTA to be paid. If the CONTRACTOR has any property in its possession belonging to MOVTA, the CONTRACTOR will account for the same, and dispose of it in the manner MOVTA directs.

b. Termination for Cause: If the CONTRACTOR does not deliver supplies in accordance with the contract delivery schedule, or, if the contract is for services, the CONTRACTOR fails to perform in the manner called for in the contract, or if the CONTRACTOR fails to comply with any other provisions of the contract, MOVTA may terminate this contract for default. Termination shall be effected by serving a notice of termination on the CONTRACTOR setting forth the manner in which the CONTRACTOR is in default. The CONTRACTOR will only be paid the contract price for supplies delivered and accepted, or services performed in accordance with the manner of performance set forth in the contract. If it is later determined by MOVTA that the CONTRACTOR had an excusable reason for not performing, such as a strike, fire, or flood, events which are not the fault of or beyond the control of the CONTRACTOR, MOVTA, after setting up a new delivery of performance schedule, may allow the CONTRACTOR to continue work, or treat the termination as a termination for convenience.

c. Opportunity to Cure: MOVTA in its sole discretion may, in the case of a termination for breach or default, allow the CONTRACTOR ten (10) business days in which to cure the defect. In such case, the notice of termination will state the time period in which cure is permitted and other appropriate conditions. If the CONTRACTOR fails to remedy to MOVTA's satisfaction the breach or default of any of the terms, covenants, or conditions of this Contract within ten (10) days after receipt by the CONTRACTOR of written notice from MOVTA setting forth the nature of said breach or default, MOVTA shall have the right to terminate the Contract without any further obligation to the CONTRACTOR. Any such termination for default shall not in any way operate to preclude MOVTA from also pursuing all available remedies against Contractor and its sureties for said breach or default.

**10. Governmentwide Debarment and Suspension**

By signing and submitting its bid or proposal, the offeror certifies as follows:

The certification in this clause is a material representation of fact relied upon by MOVTA. If it is later determined that the bidder or offeror knowingly rendered an erroneous certification, in addition to remedies available to MOVTA, the Federal Government may pursue available remedies, including but not limited to suspension and/or debarment. The bidder or offeror agrees to comply with the requirements of 49 CFR 29, Subpart C while this offer is valid and throughout the period of any contract that may arise from this offer.

The bidder or offeror further agrees to include a provision requiring such compliance in its lower tier covered transactions.

**11. Notification Related to Fraud, Waste, Abuse, or Other Legal Matters**

If a current or prospective legal matter that may affect the Federal Government emerges, the CONTRACTOR must promptly notify MOVTA so that it can notify the Federal Government. The types of legal matters that require notification include, but are not limited to, a major dispute, breach, default, litigation, or naming the Federal Government as a party to litigation or a legal disagreement in any forum for any reason. Matters that may affect the Federal Government include, but are not limited to, the

**REQUEST FOR QUOTATION**  
**ADA Compliant Lowered Floor Mini-Van**

---

Federal Government's interests in the Award, the accompanying Underlying Agreement, and any Amendments thereto, or the Federal Government's administration or enforcement of federal laws, regulations, and requirements.

The CONTRACTOR agrees to include a similar notification requirement in subcontracts exceeding \$25,000 financed in whole or in part with federal assistance provided by FTA and must require each subcontractor to include an equivalent provision in its federally assisted subcontracts exceeding \$25,000.

**12. Lobbying Restrictions**

The CONTRACTOR agrees to:

- a. Refrain from using Federal assistance funds to support lobbying,
- b. Comply and assure the compliance of each SUBCONTRACTOR at any tier, with U.S. DOT regulations, "New Restrictions on Lobbying," 49 C.F.R. Part 20, modified as necessary by 31 U.S.C. § 1352.
- c. Comply with Federal statutory provisions to the extent applicable prohibiting the use of Federal assistance funds for activities designed to influence Congress or a State legislature on legislation or appropriations, except through proper, official channels.

**13. Buy America**

The CONTRACTOR agrees to comply with 49 U.S.C. 5323(j), 49 C.F.R. part 661, Pub. L. No. 117-58, and Pub. L. No. 117-58, §§ 70901-52 which provide that Federal funds may not be obligated unless all steel, iron, and manufactured products or construction materials used in FTA funded projects are produced in the United States unless a waiver has been granted by FTA or the product is subject to a general waiver.. General waivers are listed in 49 C.F.R. §661.7, and includes microcomputer equipment, software, and small purchases (currently less than \$150,000) made with capital, operating, or planning funds. Separate requirements for rolling stock are set out at 49 U.S.C. 5323(j)(2)(C) and 49 C.F.R. 661.11. Rolling stock must be assembled in the United States and have a 70 percent domestic content. A bidder or offeror must submit to the FTA recipient the appropriate Buy America certification with all bids or offers on FTA-funded contracts, except those subject to a general waiver. Bids or offers that are not accompanied by a completed Buy America certification must be rejected as nonresponsive. This requirement does not apply to lower-tier subcontractors.

**14. Clean Air**

- a. The CONTRACTOR agrees to comply with all applicable standards, orders or regulations issued pursuant to the Clean Air Act, as amended, 42 U.S.C. §§ 7401 through 7671q. The Contractor agrees to report each violation to the Purchaser and understands and agrees that the Purchaser will, in turn, report each violation as required to assure notification to FTA and the appropriate EPA Regional Office.
- b. The CONTRACTOR also agrees to include these requirements in each subcontract exceeding \$150,000 financed in whole or in part with Federal assistance provided by FTA.

**15. Clean Water**

- a. The CONTRACTOR agrees to comply with all applicable standards, orders or regulations issued pursuant to the Clean Water Act, as amended, 33 U.S.C. §§1251 through 1377. The Contractor agrees to

**REQUEST FOR QUOTATION**  
**ADA Compliant Lowered Floor Mini-Van**

---

report each violation to the Purchaser and understands and agrees that the Purchaser will, in turn, report each violation as required to assure notification to FTA and the appropriate EPA Regional Office.

b. The CONTRACTOR also agrees to include these requirements in each subcontract exceeding \$150,000 financed in whole or in part with Federal assistance provided by FTA.

**16. Breaches and Disputes**

a. Disputes - Disputes arising in the performance of this Contract which are not resolved by agreement of the parties shall be decided in writing by the authorized representative of MOVTA. This decision shall be final and conclusive unless within ten (10) days from the date of receipt of its copy, the CONTRACTOR mails or otherwise furnishes a written appeal to MOVTA. In connection with any such appeal, the CONTRACTOR shall be afforded an opportunity to be heard and to offer evidence in support of its position. The decision of MOVTA shall be binding upon the CONTRACTOR and the CONTRACTOR shall abide by the decision.

b. Performance During Dispute - Unless otherwise directed by MOVTA, CONTRACTOR shall continue performance under this Contract while matters in dispute are being resolved.

c. Claims for Damages - Should either party to the Contract suffer injury or damage to person or property because of any act or omission of the party or of any of his employees, agents or others for whose acts he is legally liable, a claim for damages therefore shall be made in writing to such other party within a reasonable time after the first observance of such injury or damage.

d. Remedies - Unless this contract provides otherwise, all claims, counterclaims, disputes and other matters in question between MOVTA and the CONTRACTOR arising out of or relating to this agreement or its breach will be decided by arbitration if the parties mutually agree, or in a court of competent jurisdiction within the State of West Virginia.

e. Rights and Remedies - The duties and obligations imposed by the Contract Documents and the rights and remedies available thereunder shall be in addition to and not a limitation of any duties, obligations, rights and remedies otherwise imposed or available by law. No action or failure to act by MOVTA, Architect or CONTRACTOR shall constitute a waiver of any right or duty afforded any of them under the Contract, nor shall any such action or failure to act constitute an approval of or acquiescence in any breach thereunder, except as may be specifically agreed in writing.

**17. Cargo Preference - Use of United States- Flag Vessels**

To the extent applicable, the contractor agrees to comply with 46 U.S.C. §55305 and 46 C.F.R. Part 381 which includes, but is not limited to:

a. to use privately owned United States-Flag commercial vessels to ship at least 50 percent of the gross tonnage (computed separately for dry bulk carriers, dry cargo liners, and tankers) involved, whenever shipping any equipment, material, or commodities pursuant to the underlying contract to the extent such vessels are available at fair and reasonable rates for United States-Flag commercial vessels;

b. to furnish within 20 working days following the date of loading for shipments originating within the United States or within 30 working days following the date of leading for shipments originating outside the United States, a legible copy of a rated, "on-board" commercial ocean bill-of-lading in English for each shipment of cargo described in the preceding paragraph to the Division of National Cargo, Office of

REQUEST FOR QUOTATION  
ADA Compliant Lowered Floor Mini-Van

---

Market Development, Maritime Administration, Washington, DC 20590 and to the FTA recipient (through the contractor in the case of a subcontractor's bill-of-lading.)

c. to include these requirements in all subcontracts issued pursuant to this contract when the subcontract may involve the transport of equipment, material, or commodities by ocean vessel.

**18. Davis-Bacon and Copeland Anti-Kickback Acts**

The CONTRACTOR agrees to comply and assure compliance of each third party contractor and each subcontractor at any tier of the project with the following Federal laws and regulations providing protections for their employees:

a. **Minimum wages** - (i) All laborers and mechanics employed or working upon the site of the work (or under the United States Housing Act of 1937 or under the Housing Act of 1949 in the construction or development of the project), will be paid unconditionally and not less often than once a week, and without subsequent deduction or rebate on any account (except such payroll deductions as are permitted by regulations issued by the Secretary of Labor under the Copeland Act (29 C.F.R. part 3)), the full amount of wages and bona fide fringe benefits (or cash equivalents thereof) due at time of payment computed at rates not less than those contained in the wage determination of the Secretary of Labor which is attached hereto and made a part hereof, regardless of any contractual relationship which may be alleged to exist between the contractor and such laborers and mechanics.

Contributions made or costs reasonably anticipated for bona fide fringe benefits under section 1(b)(2) of the Davis-Bacon Act on behalf of laborers or mechanics are considered wages paid to such laborers or mechanics, subject to the provisions of paragraph (1)(iv) of this section; also, regular contributions made or costs incurred for more than a weekly period (but not less often than quarterly) under plans, funds, or programs which cover the particular weekly period, are deemed to be constructively made or incurred during such weekly period. Such laborers and mechanics shall be paid the appropriate wage rate and fringe benefits on the wage determination for the classification of work actually performed, without regard to skill, except as provided in 29 C.F.R. Part 5.5(a)(4). Laborers or mechanics performing work in more than one classification may be compensated at the rate specified for each classification for the time actually worked therein: Provided, that the employer's payroll records accurately set forth the time spent in each classification in which work is performed. The wage determination (including any additional classifications and wage rates conformed under paragraph (1)(ii) of this section) and the Davis-Bacon poster (WH-1321) shall be posted at all times by the contractor and its subcontractors at the site of the work in a prominent and accessible place where it can be easily seen by the workers.

(ii)(A) The contracting officer shall require that any class of laborers or mechanics, including helpers, which is not listed in the wage determination, and which is to be employed under the contract shall be classified in conformance with the wage determination. The contracting officer shall approve an additional classification and wage rate and fringe benefits therefore only when the following criteria have been met:

- (1) Except with respect to helpers as defined as 29 C.F.R. 5.2(n)(4), the work to be performed by the classification requested is not performed by a classification in the wage determination; and
- (2) The classification is utilized in the area by the construction industry; and
- (3) The proposed wage rate, including any bona fide fringe benefits, bears a reasonable relationship to the wage rates contained in the wage determination; and

**REQUEST FOR QUOTATION**  
**ADA Compliant Lowered Floor Mini-Van**

---

(4) With respect to helpers as defined in 29 C.F.R. 5.2(n)(4), such a classification prevails in the area in which the work is performed.

(B) If the contractor and the laborers and mechanics to be employed in the classification (if known), or their representatives, and the contracting officer agree on the classification and wage rate (including the amount designated for fringe benefits where appropriate), a report of the action taken shall be sent by the contracting officer to the Administrator of the Wage and Hour Division, Employment Standards Administration, U.S. Department of Labor, Washington, DC 20210. The Administrator, or an authorized representative, will approve, modify, or disapprove every additional classification action within 30 days of receipt and so advise the contracting officer or will notify the contracting officer within the 30-day period that additional time is necessary.

(C) In the event the contractor, the laborers or mechanics to be employed in the classification or their representatives, and the contracting officer do not agree on the proposed classification and wage rate (including the amount designated for fringe benefits, where appropriate), the contracting officer shall refer the questions, including the views of all interested parties and the recommendation of the contracting officer, to the Administrator for determination. The Administrator, or an authorized representative, will issue a determination within 30 days of receipt and so advise the contracting officer or will notify the contracting officer within the 30-day period that additional time is necessary.

(D) The wage rate (including fringe benefits where appropriate) determined pursuant to paragraphs (a)(1)(ii) (B) or (C) of this section, shall be paid to all workers performing work in the classification under this contract from the first day on which work is performed in the classification.

(iii) Whenever the minimum wage rate prescribed in the contract for a class of laborers or mechanics includes a fringe benefit which is not expressed as an hourly rate, the contractor shall either pay the benefit as stated in the wage determination or shall pay another bona fide fringe benefit or an hourly cash equivalent thereof.

(iv) If the contractor does not make payments to a trustee or other third person, the contractor may consider as part of the wages of any laborer or mechanic the amount of any costs reasonably anticipated in providing bona fide fringe benefits under a plan or program, provided, that the Secretary of Labor has found, upon the written request of the contractor, that the applicable standards of the Davis-Bacon Act have been met. The Secretary of Labor may require the contractor to set aside in a separate account asset for the meeting of obligations under the plan or program.

(v)(A) The contracting officer shall require that any class of laborers or mechanics which is not listed in the wage determination, and which is to be employed under the contract shall be classified in conformance with the wage determination. The contracting officer shall approve an additional classification and wage rate and fringe benefits therefore only when the following criteria have been met:

- (1) The work to be performed by the classification requested is not performed by a classification in the wage determination; and
- (2) The classification is utilized in the area by the construction industry; and
- (3) The proposed wage rate, including any bona fide fringe benefits, bears a reasonable relationship to the wage rates contained in the wage determination.

(B) If the contractor and the laborers and mechanics to be employed in the classification (if known), or their representatives, and the contracting officer agree on the classification and wage rate (including the amount designated for fringe benefits where appropriate), a report of the action taken shall be sent by the

REQUEST FOR QUOTATION  
**ADA Compliant Lowered Floor Mini-Van**

---

contracting officer to the Administrator of the Wage and Hour Division, Employment Standards Administration, Washington, DC 20210. The Administrator, or an authorized representative, will approve, modify, or disapprove every additional classification action within 30 days of receipt and so advise the contracting officer or will notify the contracting officer within the 30-day period that additional time is necessary.

(C) In the event the contractor, the laborers or mechanics to be employed in the classification or their representatives, and the contracting officer do not agree on the proposed classification and wage rate (including the amount designated for fringe benefits, where appropriate), the contracting officer shall refer the questions, including the views of all interested parties and the recommendation of the contracting officer, to the Administrator for determination. The Administrator, or an authorized representative, will issue a determination with 30 days of receipt and so advise the contracting officer or will notify the contracting officer within the 30-day period that additional time is necessary.

(D) The wage rate (including fringe benefits where appropriate) determined pursuant to paragraphs (a)(1)(v) (B) or (C) of this section, shall be paid to all workers performing work in the classification under this contract from the first day on which work is performed in the classification.

b. **Withholding** - MOVTA shall upon its own action or upon written request of an authorized representative of the Department of Labor withhold or cause to be withheld from the contractor under this contract or any other Federal contract with the same prime contractor, or any other federally-assisted contract subject to Davis-Bacon prevailing wage requirements, which is held by the same prime contractor, so much of the accrued payments or advances as may be considered necessary to pay laborers and mechanics, including apprentices, trainees, and helpers, employed by the contractor or any subcontractor the full amount of wages required by the contract. In the event of failure to pay any laborer or mechanic, including any apprentice, trainee, or helper, employed or working on the site of the work (or under the United States Housing Act of 1937 or under the Housing Act of 1949 in the construction or development of the project), all or part of the wages required by the contract, MOVTA may, after written notice to the contractor, sponsor, applicant, or owner, take such action as may be necessary to cause the suspension of any further payment, advance, or guarantee of funds until such violations have ceased.

c. **Payrolls and basic records** - (i) Payrolls and basic records relating thereto shall be maintained by the contractor during the course of the work and preserved for a period of three years thereafter for all laborers and mechanics working at the site of the work (or under the United States Housing Act of 1937, or under the Housing Act of 1949, in the construction or development of the project). Such records shall contain the name, address, and social security number of each such worker, his or her correct classification, hourly rates of wages paid (including rates of contributions or costs anticipated for bona fide fringe benefits or cash equivalents thereof of the types described in section 1(b)(2)(B) of the Davis-Bacon Act, daily and weekly number of hours worked, deductions made and actual wages paid. Whenever the Secretary of Labor has found under 29 C.F.R. 5.5(a)(1)(iv) that the wages of any laborer or mechanic include the amount of any costs reasonably anticipated in providing benefits under a plan or program described in section 1(b)(2)(B) of the Davis-Bacon Act, the contractor shall maintain records which show that the commitment to provide such benefits is enforceable, that the plan or program is financially responsible, and that the plan or program has been communicated in writing to the laborers or

**REQUEST FOR QUOTATION**  
**ADA Compliant Lowered Floor Mini-Van**

---

mechanics affected, and records which show the costs anticipated or the actual cost incurred in providing such benefits. Contractors employing apprentices or trainees under approved programs shall maintain written evidence of the registration of apprenticeship programs and certification of trainee programs, the registration of the apprentices and trainees, and the ratios and wage rates prescribed in the applicable programs.

(ii)(A) The contractor shall submit weekly for each week in which any contract work is performed a copy of all payrolls to MOVTA for transmission to the Federal Transit Administration. The payrolls submitted shall set out accurately and completely all of the information required to be maintained under section 5.5(a)(3)(i) of Regulations, 29 C.F.R. part 5. This information may be submitted in any form desired. Optional Form WH-347 is available for this purpose and may be purchased from the Superintendent of Documents (Federal Stock Number 029-005-00014-1), U.S. Government Printing Office, Washington, DC 20402. The prime contractor is responsible for the submission of copies of payrolls by all subcontractors.

(B) Each payroll submitted shall be accompanied by a "Statement of Compliance," signed by the contractor or subcontractor or his or her agent who pays or supervises the payment of the persons employed under the contract and shall certify the following:

- (1) That the payroll for the payroll period contains the information required to be maintained under section 5.5(a)(3)(i) of Regulations, 29 C.F.R. part 5 and that such information is correct and complete;
- (2) That each laborer or mechanic (including each helper, apprentice, and trainee) employed on the contract during the payroll period has been paid the full weekly wages earned, without rebate, either directly or indirectly, and that no deductions have been made either directly or indirectly from the full wages earned, other than permissible deductions as set forth in Regulations, 29 C.F.R. Part 3;
- (3) That each laborer or mechanic has been paid no less than the applicable wage rates and fringe benefits or cash equivalents for the classification of work performed, as specified in the applicable wage determination incorporated into the contract.

(C) The weekly submission of a properly executed certification set forth on the reverse side of Optional Form WH-347 shall satisfy the requirement for submission of the "Statement of Compliance" required by paragraph (a)(3)(ii)(B) of this section.

(D) The falsification of any of the above certifications may subject the contractor or subcontractor to civil or criminal prosecution under section 1001 of title 18 and section 231 of Title 31 of the United States Code.

(iii) The contractor or subcontractor shall make the records required under paragraph (a)(3)(i) of this section available for inspection, copying, or transcription by authorized representatives of the Federal Transit Administration or the Department of Labor, and shall permit such representatives to interview employees during working hours on the job. If the contractor or subcontractor fails to submit the required records or to make them available, the Federal agency may, after written notice to the contractor, sponsor, applicant, or owner, take such action as may be necessary to cause the suspension of any further payment, advance, or guarantee of funds. Furthermore, failure to submit the required records upon request or to make such records available may be grounds for debarment action pursuant to 29 C.F.R. 5.12.

**d. Apprentices and trainees** - (i) Apprentices - Apprentices will be permitted to work at less than the predetermined rate for the work they performed when they are employed pursuant to and individually

**REQUEST FOR QUOTATION**  
**ADA Compliant Lowered Floor Mini-Van**

---

registered in a bona fide apprenticeship program registered with the U.S. Department of Labor, Employment and Training Administration, Bureau of Apprenticeship and Training, or with a State Apprenticeship Agency recognized by the Bureau, or if a person is employed in his or her first 90 days of probationary employment as an apprentice in such an apprenticeship program, who is not individually registered in the program, but who has been certified by the Bureau of Apprenticeship and Training or a State Apprenticeship Agency (where appropriate) to be eligible for probationary employment as an apprentice. The allowable ratio of apprentices to journeymen on the job site in any craft classification shall not be greater than the ratio permitted to the contractor as to the entire work force under the registered program. Any worker listed on a payroll at an apprentice wage rate, who is not registered or otherwise employed as stated above, shall be paid not less than the applicable wage rate on the wage determination for the classification of work performed. In addition, any apprentice performing work on the job site in excess of the ratio permitted under the registered program shall be paid not less than the applicable wage rate on the wage determination for the work actually performed. Where a contractor is performing construction on a project in a locality other than that in which its program is registered, the ratios and wage rates (expressed in percentages of the journeyman's hourly rate) specified in the contractor's or subcontractor's registered program shall be observed. Every apprentice must be paid at not less than the rate specified in the registered program for the apprentice's level of progress, expressed as a percentage of the journeymen hourly rate specified in the applicable wage determination. Apprentices shall be paid fringe benefits in accordance with the provisions of the apprenticeship program. If the apprenticeship program does not specify fringe benefits, apprentices must be paid the full amount of fringe benefits listed on the wage determination for the applicable classification. If the Administrator of the Wage and Hour Division of the U.S. Department of Labor determines that a different practice prevails for the applicable apprentice classification, fringes shall be paid in accordance with that determination. In the event the Bureau of Apprenticeship and Training, or a State Apprenticeship Agency recognized by the Bureau, withdraws approval of an apprenticeship program, the contractor will no longer be permitted to utilize apprentices at less than the applicable predetermined rate for the work performed until an acceptable program is approved.

(ii) Trainees - Except as provided in 29 C.F.R. 5.16, trainees will not be permitted to work at less than the predetermined rate for the work performed unless they are employed pursuant to and individually registered in a program which has received prior approval, evidenced by formal certification by the U.S. Department of Labor, Employment and Training Administration. The ratio of trainees to journeymen on the job site shall not be greater than permitted under the plan approved by the Employment and Training Administration. Every trainee must be paid at not less than the rate specified in the approved program for the trainee's level of progress, expressed as a percentage of the journeyman's hourly rate specified in the applicable wage determination. Trainees shall be paid fringe benefits in accordance with the provisions of the trainee program. If the trainee program does not mention fringe benefits, trainees shall be paid the full amount of fringe benefits listed on the wage determination unless the Administrator of the Wage and Hour Division determines that there is an apprenticeship program associated with the corresponding journeyman wage rate on the wage determination which provides for less than full fringe benefits for apprentices. Any employee listed on the payroll at a trainee rate that is not registered and participating in a training plan approved by the Employment and Training Administration shall be paid not less than the applicable wage rate on the wage determination for the classification of work actually performed. In

REQUEST FOR QUOTATION  
**ADA Compliant Lowered Floor Mini-Van**

---

addition, any trainee performing work on the job site in excess of the ratio permitted under the registered program shall be paid not less than the applicable wage rate on the wage determination for the work actually performed. In the event the Employment and Training Administration withdraws approval of a training program, the contractor will no longer be permitted to utilize trainees at less than the applicable predetermined rate for the work performed until an acceptable program is approved.

(iii) Equal employment opportunity - The utilization of apprentices, trainees and journeymen under this part shall be in conformity with the equal employment opportunity requirements of Executive Order 11246, as amended, and 29 C.F.R. Part 30.

e. **Compliance with Copeland Act requirements** - The contractor shall comply with the requirements of 29 C.F.R. Part 3, which are incorporated by reference in this contract.

f. **Subcontracts** - The contractor or subcontractor shall insert in any subcontracts the clauses contained in 29 C.F.R. 5.5(a)(1) through (10) and such other clauses as the Federal Transit Administration may by appropriate instructions require, and also a clause requiring the subcontractors to include these clauses in any lower tier subcontracts. The prime contractor shall be responsible for the compliance by any subcontractor or lower tier subcontractor with all the contract clauses in 29 C.F.R. 5.5.

g. **Contract termination: debarment** - A breach of the contract clauses in 29 C.F.R. 5.5 may be grounds for termination of the contract, and for debarment as a contractor and a subcontractor as provided in 29 C.F.R. 5.12.

h. **Compliance with Davis-Bacon and Related Act requirements** - All rulings and interpretations of the Davis-Bacon and Related Acts contained in 29 C.F.R. parts 1, 3, and 5 are herein incorporated by reference in this contract.

i. **Disputes concerning labor standards** - Disputes arising out of the labor standards provisions of this contract shall not be subject to the general disputes clause of this contract. Such disputes shall be resolved in accordance with the procedures of the Department of Labor set forth in 29 C.F.R. Parts 5, 6, and 7. Disputes within the meaning of this clause include disputes between the contractor (or any of its subcontractors) and the contracting agency, the U.S. Department of Labor, or the employees or their representatives.

j. **Certification of eligibility** - (i) By entering into this contract, the contractor certifies that neither it (nor he or she) nor any person or firm who has an interest in the contractor's firm is a person or firm ineligible to be awarded Government contracts by virtue of section 3(a) of the Davis-Bacon Act or 29 C.F.R. 5.12(a)(1).

(ii) No part of this contract shall be subcontracted to any person or firm ineligible for award of a Government contract by virtue of section 3(a) of the Davis-Bacon Act or 29 C.F.R. 5.12(a)(1).

(iii) The penalty for making false statements is prescribed in the U.S. Criminal Code, 18 U.S.C. 1001.

**19. Contract Work Hours and Safety Standards Act**

The CONTRACTOR agrees to comply with and assure compliance by subcontractors and other project participants for construction employees with the Contract Work Hours and Safety Standards Act, as amended, 40 U.S.C. §§ 3701 et seq., specifically the wage and hour requirements of section 102 of that Act at 40 U.S.C. § 3702, and implementing U.S. DOL regulations, "Labor Standards Provisions Applicable to Contracts Governing Federally Financed and Assisted Construction (also Labor Standards Provisions Applicable to Nonconstruction Contracts Subject to the Contract Work Hours and safety Standards Act)," 29 C.F.R. Part 5; and the safety requirements of section 107 of that Act at 40 U.S.C. §

**REQUEST FOR QUOTATION**  
**ADA Compliant Lowered Floor Mini-Van**

---

3704, and implementing U.S. DOL regulations, "Safety and Health Regulations for Construction," 29 C.F.R. Part 1926.

The CONTRACTOR further agrees to comply with and assure compliance by other project participants for nonconstruction employees with the Contract Work Hours and Safety Standards Act, as amended, 40 U.S.C. §§ 3701 et seq., in particular with the wage and hour requirements of section 102 of that Act at 40 U.S.C. § 3702, and with implementing U.S. DOL regulations, "Labor Standards Provisions Applicable to Contracts Governing Federally Financed and Assisted Construction (also Labor Standards Provisions Applicable to Nonconstruction Contracts Subject to the Contract Work Hours and safety Standards Act)," 29 C.F.R. Part 5.

## **20. Bonding Requirements**

### **Bid Bond Requirements**

Bid Bond will be five (5) percent of the bid price and must be issued by a fully qualified surety company acceptable to MOVTA and listed as a company currently authorized under 31 C.F.R., Part 223 as possessing a Certificate of Authority as described thereunder.

In submitting this Bid, it is understood and agreed by bidder that the right is reserved by MOVTA to reject any and all bids, or part of any bid, and it is agreed that the Bid may not be withdrawn for a period of [ninety (90)] days subsequent to the opening of bids, without the written consent of MOVTA.

It is also understood and agreed that if the undersigned bidder should withdraw any part or all of his bid within [ninety (90)] days after the bid opening without the written consent of MOVTA, shall refuse or be unable to enter into this Contract, as provided above, or refuse or be unable to furnish adequate and acceptable Performance Bonds and Labor and Material Payments Bonds, or refuse or be unable to furnish adequate and acceptable insurance, he shall forfeit his bid security to the extent of MOVTA damages occasioned by such withdrawal, or refusal, or inability to enter into an agreement, or provide adequate security therefor.

It is further understood and agreed that to the extent the defaulting bidder's Bid Bond, Certified Check, Cashier's Check, Treasurer's Check, and/or Official Bank Check (excluding any income generated thereby which has been retained by MOVTA as provided in [Item x "Bid Security" of the Instructions to Bidders]) shall prove inadequate to fully recompense MOVTA for the damages occasioned by default, then the undersigned bidder agrees to indemnify MOVTA and pay over to MOVTA the difference between the bid security and MOVTA's total damages, so as to make MOVTA whole. The undersigned understands that any material alteration of any of the above or any of the material contained on this form, other than that requested, will render the bid unresponsive.

### **Performance Bonds**

1. The penal amount of performance bonds shall be 100 percent of the original contract price, unless MOVTA determines that a lesser amount would be adequate for the protection of MOVTA.
2. MOVTA may require additional performance bond protection when a contract price is increased. The increase in protection shall generally equal 100 percent of the increase in contract price. MOVTA may secure additional protection by directing the Contractor to increase the penal amount of the existing bond or to obtain an additional bond.

**REQUEST FOR QUOTATION**  
**ADA Compliant Lowered Floor Mini-Van**

---

**Payment Bonds**

A payment bond of 100 percent of the original contract price unless MOVTA determines that a lesser amount would be adequate for the protection of MOVTA.

**21. Veterans Preference**

As provided in 49 U.S.C. § 5325(k), to the extent practicable, the contractor agrees and assures that it and its subcontractors will give a hiring preference to veterans, as defined in 5 U.S.C. § 2108, who have the skills and abilities required to perform construction work required under the contract.

This does not require the contractor to give a preference to any veteran over any equally qualified applicant who is a member of any racial or ethnic minority, female, an individual with a disability, or a former employee.

**22. Seismic Safety**

The CONTRACTOR agrees that they will comply with 42 U.S.C. §7701 et seq. in accordance with Executive Order No. 12699 as well as with the standards for Seismic Safety required in Department of Transportation Seismic Safety Regulations 49 C.F.R. Part 41 and will certify to compliance to the extent required by the regulation. The CONTRACTOR also agrees to ensure that all work performed under this contract including work performed by a subcontractor is in compliance with the standards required by the Seismic Safety Regulations and the certification of compliance issued on the project.

**23. Recycled Products**

To the extent applicable, the CONTRACTOR agrees to comply with U.S. EPA regulations, "Comprehensive Procurement Guidelines for Products Containing Recovered Materials," 40 C.F.R. Part 247, implementing section 6002 of the Resource Conservation and Recovery Act, as amended, 42 U.S.C. § 6962, and otherwise provide a competitive preference for products and services that conserve natural resources and protect the environment and are energy efficient.

**24. Accessibility**

The CONTRACTOR agrees to comply with 49 U.S.C. §5301(d), which states the Federal policy that elderly individuals and individuals with disabilities have the same right as other individuals to use public transportation services and facilities, and that special efforts shall be made in planning and designing those services and facilities to implement transportation accessibility rights for elderly individuals and individuals with disabilities. The CONTRACTOR also agrees to comply with all applicable provisions of Section 504 of the Rehabilitation Act, as amended, 29 U.S.C. §794, which prohibits discrimination on the basis of disability in the administration of programs or activities receiving Federal financial assistance; with the Americans with Disabilities Act of 1990 (ADA), as amended, 42 U.S.C. §12101 et seq., which requires that accessible facilities and services be made available to individuals with disabilities; with the Architectural Barriers Act of 1968, a amended, 42 U.S.C. §4151 et seq., which requires that buildings and public accommodations be accessible to individuals with disabilities; and with other laws and amendments thereto pertaining to access for individuals with disabilities that may be applicable. In

**REQUEST FOR QUOTATION**  
**ADA Compliant Lowered Floor Mini-Van**

---

addition, the CONTRACTOR agrees to comply with applicable implementing Federal regulations and any later amendments thereto, and agrees to follow applicable Federal implementing directives, except to the extent the FTA approves otherwise in writing.

**25. Equal Employment Opportunity**

During the performance of this contract, the contractor agrees as follows:

(1) The contractor will not discriminate against any employee or applicant for employment because of race, color, religion, sex, sexual orientation, gender identity, or national origin. The contractor will take affirmative action to ensure that applicants are employed, and that employees are treated during employment without regard to their race, color, religion, sex, sexual orientation, gender identity, or national origin. Such action shall include, but not be limited to the following:

Employment, upgrading, demotion, or transfer; recruitment or recruitment advertising; layoff or termination; rates of pay or other forms of compensation; and selection for training, including apprenticeship. The contractor agrees to post in conspicuous places, available to employees and applicants for employment, notices to be provided setting forth the provisions of this nondiscrimination clause.

(2) The contractor will, in all solicitations or advertisements for employees placed by or on behalf of the contractor, state that all qualified applicants will receive consideration for employment without regard to race, color, religion, sex, sexual orientation, gender identity, or national origin.

(3) The contractor will not discharge or in any other manner discriminate against any employee or applicant for employment because such employee or applicant has inquired about, discussed, or disclosed the compensation of the employee or applicant or another employee or applicant. This provision shall not apply to instances in which an employee who has access to the compensation information of other employees or applicants as a part of such employee's essential job functions discloses the compensation of such other employees or applicants to individuals who do not otherwise have access to such information, unless such disclosure is in response to a formal complaint or charge, in furtherance of an investigation, proceeding, hearing, or action, including an investigation conducted by the employer, or is consistent with the contractor's legal duty to furnish information.

(4) The contractor will send to each labor union or representative of workers with which he has a collective bargaining agreement or other contract or understanding, a notice to be provided advising the said labor union or workers' representatives of the contractor's commitments under this section, and shall post copies of the notice in conspicuous places available to employees and applicants for employment.

(5) The contractor will comply with all provisions of Executive Order 11246 of September 24, 1965, and of the rules, regulations, and relevant orders of the Secretary of Labor.

(6) The contractor will furnish all information and reports required by Executive Order 11246 of September 24, 1965, and by rules, regulations, and orders of the Secretary of Labor, or pursuant thereto, and will permit access to his books, records, and accounts by the administering agency and the Secretary of Labor for purposes of investigation to ascertain compliance with such rules, regulations, and orders.

(7) In the event of the contractor's noncompliance with the nondiscrimination clauses of this contract or with any of the said rules, regulations, or orders, this contract may be canceled, terminated, or suspended in whole or in part and the contractor may be declared ineligible for further Government contracts or federally assisted construction contracts in accordance with procedures authorized in Executive Order

**REQUEST FOR QUOTATION**  
**ADA Compliant Lowered Floor Mini-Van**

---

11246 of September 24, 1965, and such other sanctions may be imposed and remedies invoked as provided in Executive Order 11246 of September 24, 1965, or by rule, regulation, or order of the Secretary of Labor, or as otherwise provided by law.

(8) The contractor will include the portion of the sentence immediately preceding paragraph (1) and the provisions of paragraphs (1) through (8) in every subcontract or purchase order unless exempted by rules, regulations, or orders of the Secretary of Labor issued pursuant to section 204 of Executive Order 11246 of September 24, 1965, so that such provisions will be binding upon each subcontractor or vendor. The contractor will take such action with respect to any subcontract or purchase order as the administering agency may direct as a means of enforcing such provisions, including sanctions for noncompliance: Provided, however, that in the event a contractor becomes involved in, or is threatened with, litigation with a subcontractor or vendor as a result of such direction by the administering agency, the contractor may request the United States to enter into such litigation to protect the interests of the United States. The applicant further agrees that it will be bound by the above equal opportunity clause with respect to its own employment practices when it participates in federally assisted construction work: Provided, That if the applicant so participating is a State or local government, the above equal opportunity clause is not applicable to any agency, instrumentality or subdivision of such government which does not participate in work on or under the contract.

The applicant agrees that it will assist and cooperate actively with the administering agency and the Secretary of Labor in obtaining the compliance of contractors and subcontractors with the equal opportunity clause and the rules, regulations, and relevant orders of the Secretary of Labor, that it will furnish the administering agency and the Secretary of Labor such information as they may require for the supervision of such compliance, and that it will otherwise assist the administering agency in the discharge of the agency's primary responsibility for securing compliance.

The applicant further agrees that it will refrain from entering into any contract or contract modification subject to Executive Order 11246 of September 24, 1965, with a contractor debarred from, or who has not demonstrated eligibility for, Government contracts and federally assisted construction contracts pursuant to the Executive Order and will carry out such sanctions and penalties for violation of the equal opportunity clause as may be imposed upon contractors and subcontractors by the administering agency or the Secretary of Labor pursuant to Part II, Subpart D of the Executive Order. In addition, the applicant agrees that if it fails or refuses to comply with these undertakings, the administering agency may take any or all of the following actions: Cancel, terminate, or suspend in whole or in part this grant (contract, loan, insurance, guarantee); refrain from extending any further assistance to the applicant under the program with respect to which the failure or refund occurred until satisfactory assurance of future compliance has been received from such applicant; and refer the case to the Department of Justice for appropriate legal proceedings.

Each nonexempt prime contractor or subcontractor shall include the equal opportunity clause in each of its nonexempt subcontracts.

**26. Seat Belt Use**

The Contractor agrees to adopt and promote on-the-job seat belt use policies and programs for its employees and other personnel that operate company-owned vehicles, company-rented vehicles, or personally operated vehicles.

REQUEST FOR QUOTATION  
**ADA Compliant Lowered Floor Mini-Van**

---

**27. Distracted Driving**

The Contractor agrees to adopt and enforce workplace safety policies to decrease crashes caused by distracted drivers, including policies to ban text messaging while using an electronic device supplied by an employer, and driving a vehicle the driver owns or rents, a vehicle Recipient owns, leases, or rents, or a privately-owned vehicle when on official business in connection with the Award, or when performing any work for or on behalf of the project.

The Contractor agrees to conduct workplace safety initiatives in a manner commensurate with its size, such as establishing new rules and programs to prohibit text messaging while driving, re-evaluating the existing programs to prohibit text messaging while driving, and providing education, awareness, and other outreach to employees about the safety risks associated with texting while driving.

The Contractor agrees to include the preceding Special Provision in its subcontractor agreements.