



The following documentation is an electronically-submitted vendor response to an advertised solicitation from the *West Virginia Purchasing Bulletin* within the Vendor Self-Service portal at *wvOASIS.gov*. As part of the State of West Virginia's procurement process, and to maintain the transparency of the bid-opening process, this documentation submitted online is publicly posted by the West Virginia Purchasing Division at *WVPurchasing.gov* with any other vendor responses to this solicitation submitted to the Purchasing Division in hard copy format.

Header 5

List View

General Information

Contact

Default Values

Discount

Document Information

Clarification Request

Procurement Folder: 1387185

Procurement Type: Central Master Agreement

Vendor ID: VS0000004719

Legal Name: Rohrer Enterprises Inc

Alias/DBA:

Total Bid: \$795,270.00

Response Date: 05/30/2024

Response Time: 8:12

Responded By User ID: TClawson

First Name: Teresa

Last Name: Clawson

Email: tclawson@rohrerbus.com

Phone: 800-735-3900

SO Doc Code: CRFQ

SO Dept: 0810

SO Doc ID: DMT2400000006

Published Date: 5/13/24

Close Date: 5/30/24

Close Time: 13:30

Status: Closed

Solicitation Description: ADA Compliant Lowered Floor Minivans

Total of Header Attachments: 5

Total of All Attachments: 5



Department of Administration
 Purchasing Division
 2019 Washington Street East
 Post Office Box 50130
 Charleston, WV 25305-0130

**State of West Virginia
 Solicitation Response**

Proc Folder: 1387185
Solicitation Description: ADA Compliant Lowered Floor Minivans
Proc Type: Central Master Agreement

Solicitation Closes	Solicitation Response	Version
2024-05-30 13:30	SR 0810 ESR05292400000007385	1

VENDOR
 VS0000004719
 Rohrer Enterprises Inc

Solicitation Number: CRFQ 0810 DMT2400000006
Total Bid: 795270
Response Date: 2024-05-30
Response Time: 08:12:40
Comments:

FOR INFORMATION CONTACT THE BUYER
 John W Estep
 304-558-2566
 john.w.estep@wv.gov

Vendor Signature X **FEIN#** **DATE**

All offers subject to all terms and conditions contained in this solicitation

Line	Comm Ln Desc	Qty	Unit Issue	Unit Price	Ln Total Or Contract Amount
1	ADA Lowered Floor Minivans	10.00000	EA	79527.000000	795270.00

Comm Code	Manufacturer	Specification	Model #
25101502			

Commodity Line Comments: Thank you for the opportunity to provide Braunability product to the State of West Virginia.
Any questions please call David Clawson at 540-729-3751
Class B Unit Price is \$76,963.00.
WVOasis solicitation response did not allow for submission of line 2.

Extended Description:

To establish an open-ended contract for ADA Lowered Floor Minivans. These vehicles will not possess any graphics.

ROHRER

School & Commercial Bus Sales

May 28, 2024

Department of Administration
Purchasing Division
2019 Washington St. E
Charleston, WV 25305

RE: PTR240000006 ADA Compliant Lowered Floor Minivans

Dear Mr. Estep,

Rohrer Bus Sales appreciates the opportunity to submit a proposal for RFQ PTR24*6 ADA Lowered Floor Minivans. Our offering is a 2024 Chrysler Voyager LX with a Braun Side Entry Manual Ramp conversion. Conversion location will be BraunAbility in Winimac, IN. Our contact there is Scott Alexander with field representation by Kevin Shidler. Our offering meets the intent and letter of your specifications with the following documentation, clarifications and/or explanations.



1515 State Road, P.O. Box 100, Duncannon, Pennsylvania 17020-0100 • OFFICE 717.957.2141 • TOLL FREE 800.735.3900 •

FAX 717.957.4884

rohrerbus.com

Table of Contents

Enclosure 1	Exhibit A Pricing Page, Flooring choices and Memo of Understanding concerning training
Enclosure 2	Signed Bid Forms and Bid Documents
Enclosure 3	Addendum Acknowledgement and No Debt Affidavit
Enclosure 4	Additional Technical Documentation and Proposed Warranty

As requested, a list of five (5) users names, addresses, emails and telephone numbers who have been provided similar equipment

REFERENCE #1: Pennsylvania Department of General Services

Rohrer Bus Sales has held the state contract for Pennsylvania since 2007 and currently holds a contract. This contract contains shuttle bus products from 21' – 31' in length and includes Ford, Chevrolet and Freightliner chassis. This contract also includes wheelchair minivan conversions. We used a senior manager in PennDOT as our reference

Contact: John Levitsky, Program Manager
Department of General Services
Bureau of Procurement
555 Walnut Street, 6th Floor Forum Place
Harrisburg, PA 17101
717-787-1206
jlevitsky@pa.gov

REFERENCE #2 - UPMC

Operates a fleet of 60+ shuttle buses including passenger and paratransit conversions. They typically complete CNG conversions on their buses.

Contact: Tom Abel, Fleet Manager.
UPMC International Limousine Service
1920 Forbes Ave
Pittsburgh, PA
412-906-1294
abelt@upmc.edu

REFERENCE #3 - Harrisburg International Airport

For over twenty years, Rohrer Bus Sales has provided Ford and Chevrolet cutaways, Freightliner M2, rear engine and low floor buses to HIA.

Contact: Robert Gardner, Vehicle Maintenance Supervisor
513 Airport Drive
Middletown, PA 17057
717-948-3900
bobg@saraa.org

REFERENCE #4 - MOVTA

Contract history extends for multiple years - Rohrer Bus Sales has provided Ford F-550, E-350 and E-450 buses to MOVTA.

Contact: Michael Kesterson
Mid-Ohio Valley Transit Authority
520 Juliana Street
Parkersburg, WV 26101
304.422.4100

REFERENCE #5 - Mountain Line Transit

Contract history extends for multiple years - Rohrer Bus Sales has provided Ford Freightliner and Ford E-350/450 buses to Mountain Line.

Contact: Maria Smith, General Manager
520 Juliana Street
420 Dupont Road
Morgantown WV 26501
304.296.3680

Please contact us immediately at (800) 735-3900 if any additional documentation is required.

Thank you for your consideration,

David M Clawson
Senior Vice President Sales



ROHRER

1.800.735.3900
540.729.3751 Cell
717.957.4884 Fax

dclawson@rohrerbus.com

**REQUEST FOR QUOTATION
ADA LOWERED FLOOR MINIVANS
EXHIBIT A PRICING PAGE**

Class	Vehicle Description	Unit Price Per Vehicle	Estimated Quantity	Extended Price
A	Vehicle, One wheelchair Position, White, No Stripes or Logos, Stowaway Ramp Under Floor	\$79,527.00	10	\$795,270.00
B	Vehicle, One Wheelchair Position, White, No Stripes or Logos, Foldaway Ramp	\$76,963.00	1	\$76,963.00

TOTAL BID EVALUATION	\$872,233.00
-----------------------------	---------------------

Complete form provided

Please note these are only estimated quantities and do not reflect any guarantee of purchase

The DMT may purchase more or less as needed.

Please do not alter Pricing Page

ROHRER

School & Commercial Bus Sales

Memorandum of Understanding

RE: Minivan Bid

Date: May 28, 2024

Rohrer Bus Sales understands as a vehicle contract recipient in the State of West Virginia, that we will be called upon to fully support joint Training in two or three locations in the state. It is our responsibility to arrange for LIFT, AC and other major component representatives to assist us with this training.

In years past we have also provided either breakfast or lunch meals. CENTRA and KRT have both allowed WVDPT to host this required training at their location. It is most helpful to have a combination of in class and hands on training out in the shop.

Sincerely,

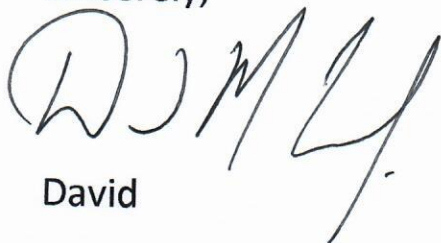

David

D.M. Clawson, Jr.

Sr. Vice President of Sales

Rohrer Bus Sales

dclawson@rohrerbus.com

Office: 717-957-2141 ext.1363

Fax: 717-957-4884

Mobile: (540) 729 – 3751

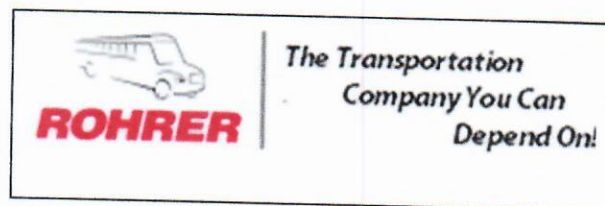

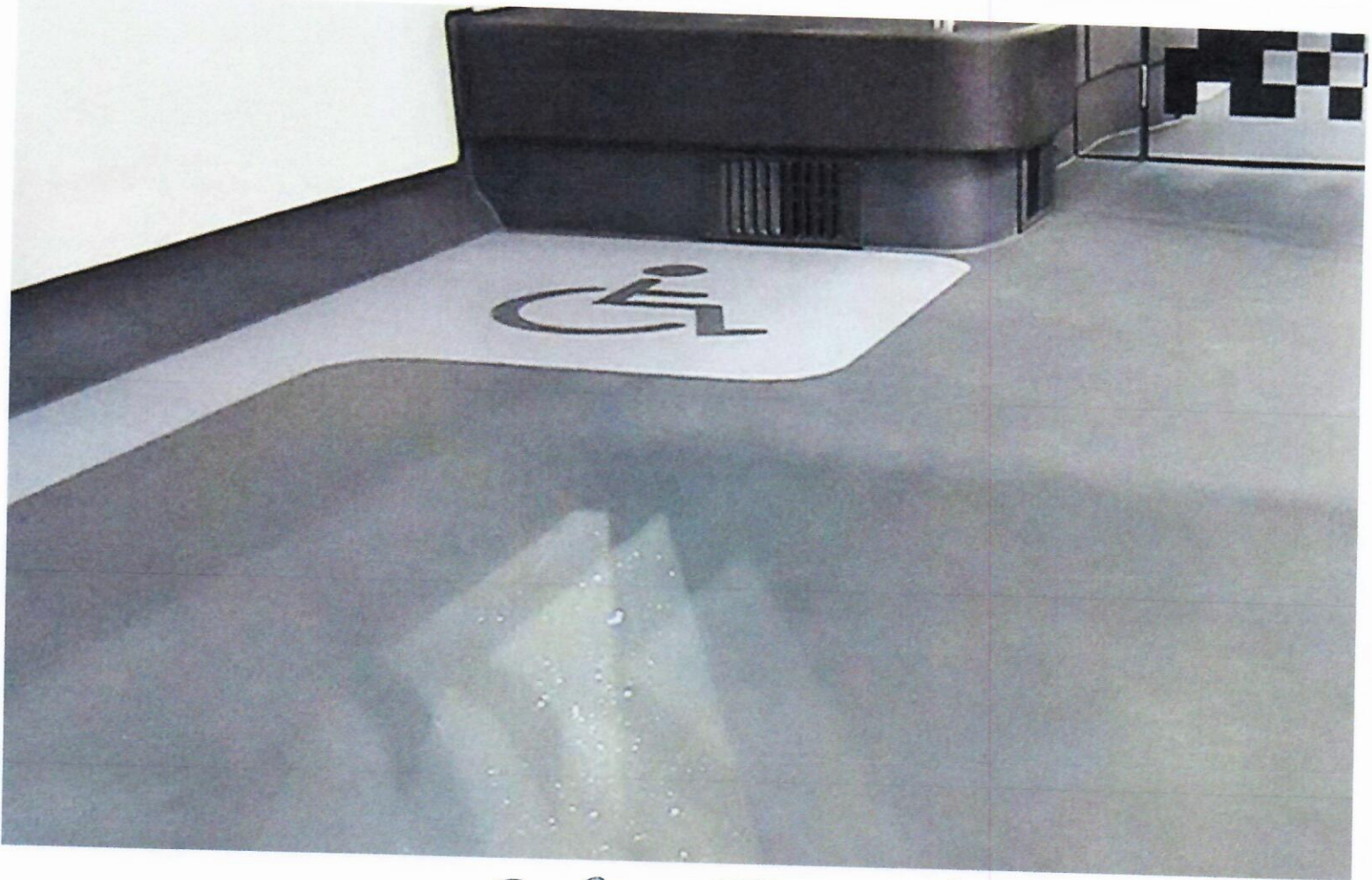

Gen floor Tarabus Sirius Specifications

High performance floor covering designed for high traffic.

- Glass fiber web : dimensional stability
- Textile backing : gluing capabilities
- Emboss : antisliding
- Compact Wear layer : durability, easy maintenance
- Silicon carbide particles : maximum durability and antisliding, aesthetic
- **Weight reduction** for Sirius NT : Fuel Savings / Lower CO² emissions

Colors

SIRIUS



https://us.tarabusbygerflor.com/products/color/400127663.html?color_product_id=400148557

6768 Griffon NT/MK

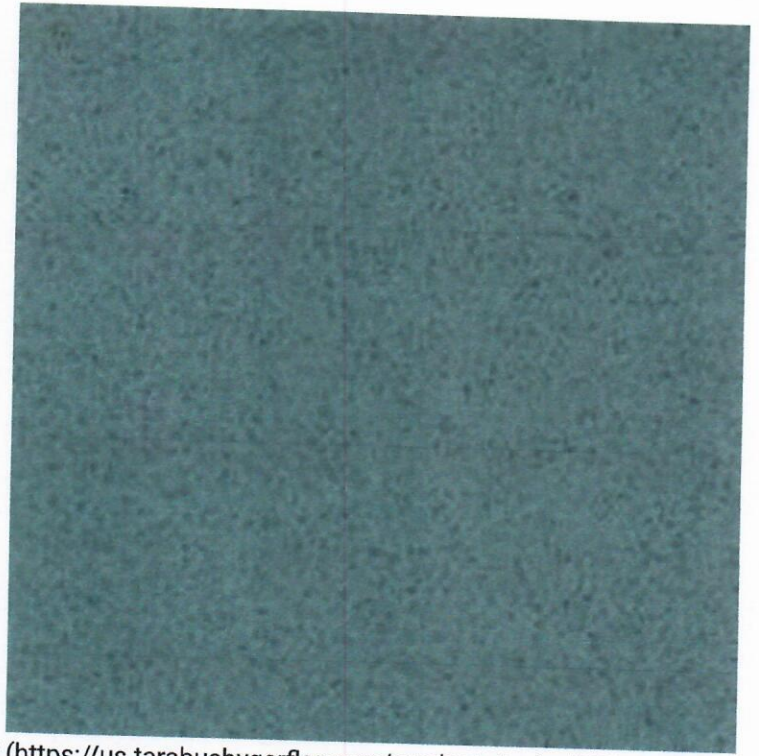

https://us.tarabusbygerflor.com/products/color/400127559.html?color_product_id=400148556

6782 Dune NT/MK

Use Graphite 6801

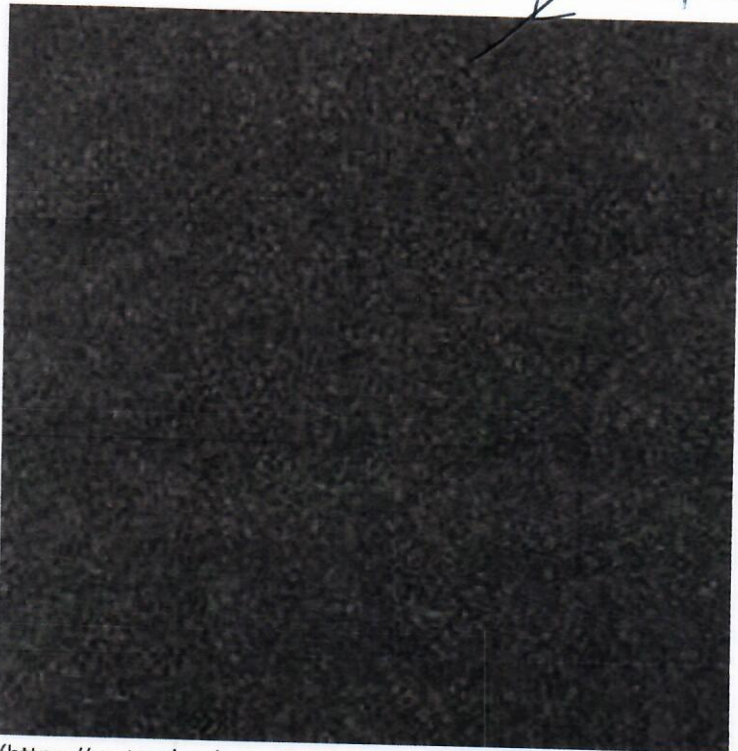

https://us.tarabusbygerflor.com/products/color/400127655.html?color_product_id=400148554

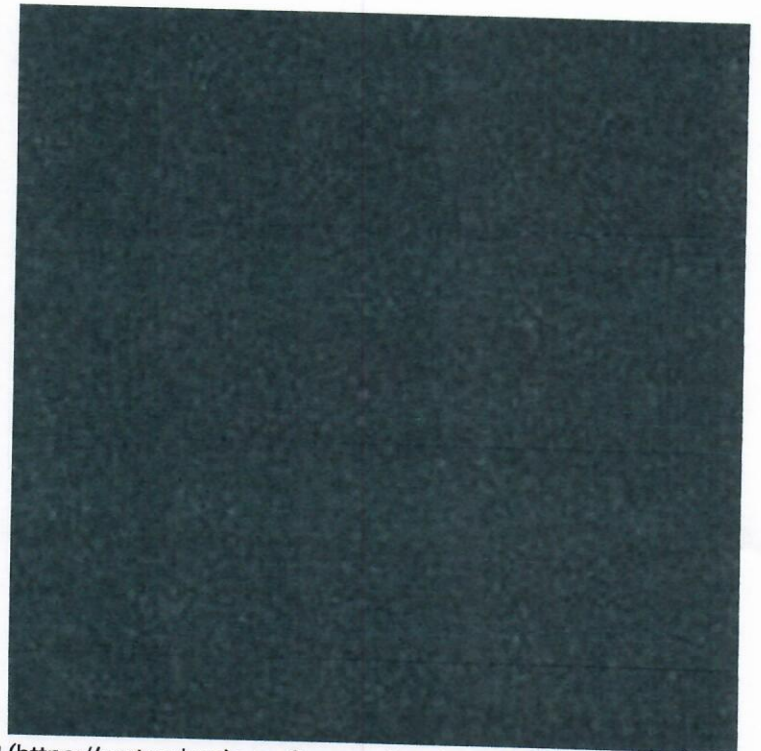

https://us.tarabusbygerflor.com/products/color/400127510.html?color_product_id=400148555

REQUEST FOR QUOTATION
ADA Compliant Lowered Floor Minivans

BID FORM #1

REQUIRED BID FORM TO BE SUBMITTED WITH BID

Location(s) of the Technical Service Representative(s) and parts distribution center(s) closest or in the State of West Virginia.

Location(s) of the technical service representative(s).

Name: Rohrer Bus Sales

Address: 1515 State Road PO Box 100
Duncannon, PA 17020

Telephone: 800-735-3900/540-729-3751

Name: _____

Address: _____

Telephone: _____

Location(s) of parts distribution center(s).

Name: Rohrer Bus Sales

Address: 1515 State Road PO Box 100
Duncannon, PA 17020

Telephone: 800-735-3900/540-729-3751

Name: _____

Address: _____

Telephone: _____

REQUEST FOR QUOTATION
ADA Compliant Lowered Floor Minivans

BID FORM #2

**CERTIFICATION FOR AIR & WATER POLLUTION
REQUIRED BID FOR TO BE SUBMITTED WITH BID**

The Vendor certifies that the vehicles proposed:

ARE in compliance with the regulations in 40 CFR Part 85, 40 CFR Part 86,
40 CFR Part 600, Clean Water Act and the air/water pollution criteria established by the
Environmental Protection Agency of the United States Government.

ARE NOT in compliance with the regulations in 40 CFR Part 85, 40 CFR Part 86,
40 CFR Part 600, Clean Water Act and the air/water pollution criteria established by the
Environmental Protection Agency of the United States Government.

5/29/24

Date

Authorized Signature

Senior Vice President Sales

Title

Rohrer Enterprises, Inc. DBA Rohrer Bus Sales

Company Name

REQUEST FOR QUOTATION
ADA Compliant Lowered Floor Minivans

BID FORM #2

**CERTIFICATION FOR AIR & WATER POLLUTION
REQUIRED BID FOR TO BE SUBMITTED WITH BID**

The Vendor certifies that the vehicles proposed:

ARE X in compliance with the regulations in 40 CFR Part 85, 40 CFR Part 86, 40 CFR Part 600, Clean Water Act and the air/water pollution criteria established by the Environmental Protection Agency of the United States Government.

ARE NOT _____ in compliance with the regulations in 40 CFR Part 85, 40 CFR Part 86, 40 CFR Part 600, Clean Water Act and the air/water pollution criteria established by the Environmental Protection Agency of the United States Government.

May 21, 2024

Date

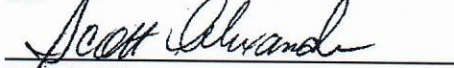
Authorized Signature

Scott Alexander, Associate Director, Commercial Inside Sales

Title

The Braun Corporation

Company Name

REQUEST FOR QUOTATION
ADA Compliant Lowered Floor Minivans

BID FORM #3

**DISADVANTAGED BUSINESS ENTERPRISE
VENDORS/ MANUFACTURERS CERTIFICATION**

REQUIRED BID FOR TO BE SUBMITTED WITH BID

(Check appropriate statement)

The Vendor, if a transit vehicle manufacturer, hereby certifies that it has complied with the requirements of 49 CFR Section 26.49 by submitting an annual DBE goal to the Federal Transit Administration (FTA). The goal has either been approved or not disapproved by FTA.

The Vendor, if a non-manufacturing supplier, hereby certifies that the manufacturer of the transit vehicle to be supplied has complied with the above-referenced requirement of 49 CFR Section 26.49.

Date

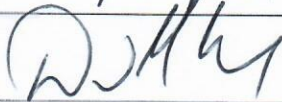
5/29/24

Authorized Signature

Senior Vice President Sales

Title

Rohrer Enterprises, Inc. DBA Rohrer Bus Sales

Company Name

REQUEST FOR QUOTATION
ADA Compliant Lowered Floor Minivans

BID FORM #3

**DISADVANTAGED BUSINESS ENTERPRISE
VENDORS/ MANUFACTURERS CERTIFICATION**

REQUIRED BID FOR TO BE SUBMITTED WITH BID

(Check appropriate statement)

The Vendor, if a transit vehicle manufacturer, hereby certifies that it has complied with the requirements of 49 CFR Section 26.49 by submitting an annual DBE goal to the Federal Transit Administration (FTA). The goal has either been approved or not disapproved by FTA.

The Vendor, if a non-manufacturing supplier, hereby certifies that the manufacturer of the transit vehicle to be supplied has complied with the above-referenced requirement of 49 CFR Section 26.49.

May 21, 2024

Date

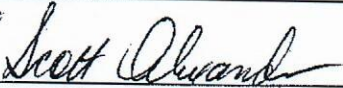

Authorized Signature

Scott Alexander, Associate Director, Commercial Inside Sales

Title

The Braun Corporation

Company Name

REQUEST FOR QUOTATION
ADA Compliant Lowered Floor Minivans

BID FORM #4

**BUY AMERICA CERTIFICATION
ROLLING STOCK
REQUIRED BID FOR TO BE SUBMITTED WITH BID**

Certificate of Compliance

The bidder or offeror hereby certifies that it will comply with the requirements of section 165(b) (3), of the Surface Transportation Assistance Act of 1982, as amended, and the applicable regulations of 49 CFR 661.11:

Date 5-29-24
[Signature]

Authorized Signature

Rohrer Enterprises, Inc. DBA Rohrer Bus Sales

Company Name

David M Clawson

Name

Senior Vice President Sales

Title

Certificate for Non-Compliance

The bidder or offeror hereby certifies that it cannot comply with the requirements of section 165(b) (3) of the Surface Transportation Assistance Act of 1982, as amended, but may qualify for an exception to the requirement consistent with section 165(b) (2) or (b) (4) of the Surface Transportation Assistance Act, as amended, and the applicable regulations in 49 CFR 661.7.

Date _____

Authorized Signature _____

Company Name _____

Name _____

Title _____

BID FORM #5

REQUEST FOR QUOTATION
ADA Compliant Lowered Floor Minivans

BID FORM #4

BUY AMERICA CERTIFICATION
ROLLING STOCK
REQUIRED BID FOR TO BE SUBMITTED WITH BID

Certificate of Compliance

The bidder or offeror hereby certifies that it will comply with the requirements of section 165(b) (3), of the Surface Transportation Assistance Act of 1982, as amended, and the applicable regulations of 49 CFR 661.11:

May 21, 2024

Date

Authorized Signature

The Braun Corporation

Company Name

Scott Alexander

Name

Associate Director, Commercial Inside Sales

Title

Certificate for Non-Compliance

The bidder or offeror hereby certifies that it cannot comply with the requirements of section 165(b) (3) of the Surface Transportation Assistance Act of 1982, as amended, but may qualify for an exception to the requirement consistent with section 165(b) (2) or (b) (4) of the Surface Transportation Assistance Act, as amended, and the applicable regulations in 49 CFR 661.7.

Date

Authorized Signature

Company Name

Name

Title

BID FORM #5

Revised 03/13/2024.

REQUEST FOR QUOTATION
ADA Compliant Lowered Floor Minivans

**FEDERAL MOTOR VEHICLE
SAFETY STANDARDS CERTIFICATION**

REQUIRED BID FORM TO BE SUBMITTED WITH BID

The vendor hereby certifies that it shall submit, as required by Title 49 of the CFR, Part 663 - Subpart D, its self-certification information stating that the vehicle(s) will comply with the relevant Federal Motor Vehicle Safety Standards issued by the National Highway Traffic Safety Administration in Title 49 of the Code of Federal Regulations, Part 571.

5/29/24

Date

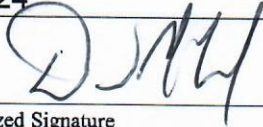
Authorized Signature

Senior Vice President Sales

Title

Rohrer Enterprises, Inc. DBA Rohrer Bus Sales

Company Name

REQUEST FOR QUOTATION
ADA Compliant Lowered Floor Minivans

FEDERAL MOTOR VEHICLE
SAFETY STANDARDS CERTIFICATION

REQUIRED BID FORM TO BE SUBMITTED WITH BID

The vendor hereby certifies that it shall submit, as required by Title 49 of the CFR, Part 663 - Subpart D, it's self-certification information stating that the vehicle(s) will comply with the relevant Federal Motor Vehicle Safety Standards issued by the National Highway Traffic Safety Administration in Title 49 of the Code of Federal Regulations, Part 571.

May 21, 2024

Date

Authorized Signature

Scott Alexander, Associate Director, Commercial Inside Sales

Title

The Braun Corporation

Company Name

REQUEST FOR QUOTATION
ADA Compliant Lowered Floor Minivans

BID FORM #6
U.S. Comptroller's Debarment List Certification
REQUIRED BID FOR TO BE SUBMITTED WITH BID

Rohrer Enterprises, Inc. DBA Rohrer Bus Sales hereby certifies that it

 IS or

IS NOT (specify one) included on the U.S. GSA's debarment and suspension information available at <https://www.sam.gov>.

5/29/24

Date

Authorized Signature

Senior Vice President Sales

Title

Rohrer Enterprises, Inc. DBA Rohrer Bus Sales
Company Name

REQUEST FOR QUOTATION
ADA Compliant Lowered Floor Minivans

BID FORM #6
U.S. Comptroller's Debarment List Certification
REQUIRED BID FOR TO BE SUBMITTED WITH BID

The Braun Corporation hereby certifies that it

 IS or

IS NOT (specify one) included on the U.S. GSA's debarment and suspension information available at <https://www.sam.gov>.

May 21, 2024

Date

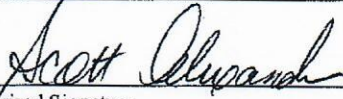

Authorized Signature

Scott Alexander, Associate Director, Commercial Inside Sales

Title

The Braun Corporation

Company Name

REQUEST FOR QUOTATION
ADA Compliant Lowered Floor Minivans

BID FORM #7

REQUIRED BID FOR TO BE SUBMITTED WITH BID

**CERTIFICATION OF PRIMARY PARTICIPANT REGARDING
DEBARMENT, SUSPENSION, AND OTHER RESPONSIBILITY MATTERS**

The Primary Participant (applicant for an FTA grant or cooperative agreement, or potential contractor for a major third party contract),

Rohrer Enterprises, Inc. DBA Rohrer Bus Sales (COMPANY NAME) certifies to the best of its knowledge and belief, that it and its principals:

1. Are not presently debarred, suspended, proposed for debarment, declared ineligible, or voluntarily excluded from covered transactions by any Federal department or agency;
2. Have not within a three-year period preceding this proposal been convicted of or had a civil judgment rendered against them for commission of fraud or a criminal offense in connection with obtaining, attempting to obtain, or performing a public (Federal, State or local) transaction or contract under a public transaction; violation of Federal or State antitrust statutes or commission of embezzlement, theft, forgery, bribery, falsification or destruction of records, making false statements, or receiving stolen property.
3. Are not presently indicted for or otherwise criminally or civilly charged by a governmental entity (Federal, State or local) with commission of any of the offenses enumerated in paragraph (2) of this certification; and
4. Have not within a three-year period preceding this application/proposal had one or more public transactions (Federal, State or local) terminated for cause or default.

If the primary participant (applicant for an FTA grant, or cooperative agreement, or potential third party contractor) is unable to certify to any of the statements in this certification, the participant shall attach an explanation to this certification.)

THE PRIMARY PARTICIPANT (APPLICANT FOR AN FTA GRANT OR COOPERATIVE AGREEMENT, OR POTENTIAL CONTRACTOR FOR A MAJOR THIRD PARTY CONTRACT), Rohrer Enterprises, Inc. DBA Rohrer Bus Sales CERTIFIES OR AFFIRMS THE TRUTHFULNESS AND ACCURACY OF THE CONTENTS OF THE STATEMENTS SUBMITTED ON OR WITH THIS CERTIFICATION AND UNDERSTANDS THAT THE PROVISIONS OF 31 U.S.C. SECTIONS 3801 ET SEQ. ARE APPLICABLE THERETO.

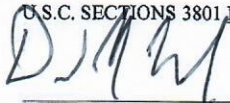

, Senior Vice President Sales

Signature and Title of Authorized Official

REQUEST FOR QUOTATION
ADA Compliant Lowered Floor Minivans

BID FORM #7

REQUIRED BID FOR TO BE SUBMITTED WITH BID
CERTIFICATION OF PRIMARY PARTICIPANT REGARDING
DEBARMENT, SUSPENSION, AND OTHER RESPONSIBILITY MATTERS

The Primary Participant (applicant for an FTA grant or cooperative agreement, or potential contractor for a major third party contract),
The Braun Corporation (COMPANY NAME) certifies to the best of its knowledge and belief, that it and its principals:

1. Are not presently debarred, suspended, proposed for debarment, declared ineligible, or voluntarily excluded from covered transactions by any Federal department or agency;
2. Have not within a three-year period preceding this proposal been convicted of or had a civil judgment rendered against them for commission of fraud or a criminal offense in connection with obtaining, attempting to obtain, or performing a public (Federal, State or local) transaction or contract under a public transaction; violation of Federal or State antitrust statutes or commission of embezzlement, theft, forgery, bribery, falsification or destruction of records, making false statements, or receiving stolen property.
3. Are not presently indicted for or otherwise criminally or civilly charged by a governmental entity (Federal, State or local) with commission of any of the offenses enumerated in paragraph (2) of this certification; and
4. Have not within a three-year period preceding this application/proposal had one or more public transactions (Federal, State or local) terminated for cause or default.

If the primary participant (applicant for an FTA grant, or cooperative agreement, or potential third party contractor) is unable to certify to any of the statements in this certification, the participant shall attach an explanation to this certification.)

THE PRIMARY PARTICIPANT (APPLICANT FOR AN FTA GRANT OR COOPERATIVE AGREEMENT, OR POTENTIAL CONTRACTOR FOR A MAJOR THIRD PARTY CONTRACT),
The Braun Corporation, CERTIFIES OR AFFIRMS THE TRUTHFULNESS AND ACCURACY OF THE CONTENTS OF THE STATEMENTS SUBMITTED ON OR WITH THIS CERTIFICATION AND UNDERSTANDS THAT THE PROVISIONS OF 31 U.S.C. SECTIONS 3801 ET SEQ. ARE APPLICABLE THERETO.

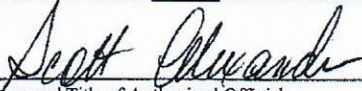

Signature and Title of Authorized Official

Scott Alexander, Associate Director, Commercial Inside Sales

Revised 03/13/2024

REQUEST FOR QUOTATION
ADA Compliant Lowered Floor Mini-Van

BID FORM #8
REQUIRED BID FOR TO BE SUBMITTED WITH BID

**VENDOR'S CERTIFICATION OF
UNDERSTANDING AND ACCEPTANCE**

The Vendor hereby certifies that all Technical Specifications and Contract Terms and Conditions have been carefully reviewed, are fully understood and shall be adhered to in performance and completion of any contract resulting from this bid.

5/29/24

Date

Authorized Signature

Senior Vice President Sales

Title

Rohrer Enterprises, Inc. DBA Rohrer Bus Sales
Company Name

SPECIFICATION COMPLIANCE

NOTE: Please check if what is offered is in exact compliance with specifications. Any discrepancies must be listed as an attachment to the bid proposal. Exact dimensions and/or descriptions must be provided as a part of the Vendor's bid proposal when submitted.

Bid proposal submitted meets and/or exceeds all specification requirements.

Bid proposal submitted contains deviations from specification requirements. Detailed descriptions of these deviations have been provided with this bid proposal.

REQUEST FOR QUOTATION
ADA Compliant Lowered Floor Mini-Van

BID FORM #8
REQUIRED BID FOR TO BE SUBMITTED WITH BID

**VENDOR'S CERTIFICATION OF
UNDERSTANDING AND ACCEPTANCE**

The Vendor hereby certifies that all Technical Specifications and Contract Terms and Conditions have been carefully reviewed, are fully understood and shall be adhered to in performance and completion of any contract resulting from this bid.

May 21, 2024

Date

Authorized Signature

Scott Alexander, Associate Director, Commercial Inside Sales

Title

The Braun Corporation

Company Name

SPECIFICATION COMPLIANCE

NOTE: Please check if what is offered is in exact compliance with specifications. Any discrepancies must be listed as an attachment to the bid proposal. Exact dimensions and/or descriptions must be provided as a part of the Vendor's bid proposal when submitted.

Bid proposal submitted meets and/or exceeds all specification requirements.

Bid proposal submitted contains deviations from specification requirements. Detailed descriptions of these deviations have been provided with this bid proposal.

REQUEST FOR QUOTATION
ADA Compliant Lowered Floor Mini-Van

BID FORM #9
REQUIRED BID FOR TO BE SUBMITTED WITH BID

CERTIFICATION OF RESTRICTIONS ON LOBBYING

The undersigned (Vendor, Contractor) certifies, to the best of his or her knowledge and belief, that:

1. No Federal appropriated funds have been paid or will be paid by or on behalf of the undersigned, to any person for influence or attempt to influence an officer or employee of any Federal agency, a Member of Congress, an officer or employee of Congress, or an employee of a Member of Congress regarding the award of a Federal grant, loan (including a line of credit), cooperative agreement, loan guarantee, or loan insurance, or the extension, continuation, renewal, amendment, or modification of any Federal grant, loan (including a line of credit), cooperative agreement, loan guarantee, or loan insurance.
2. If any funds other than Federal appropriated funds have been or will be paid to any person to influence or attempt to influence an officer or employee of any Federal agency, a Member of Congress, an officer or employee of Congress, or any employee of a Member of Congress in connection with any application for a Federal grant, loan (including a line of credit), cooperative agreement, loan guarantee, or loan insurance, the undersigned assures that it will complete and submit Standard Form-LLL, "Disclosure of Lobbying Activities," Rev. 7-97; and
3. The undersigned understands that the language of this certification shall be included in the award documents for all sub awards at all tiers (including subcontracts, sub grants, sub agreements, and contracts under grants, loans (including a line of credit), cooperative agreements, loan guarantees, and loan insurance.

Undersigned understands that this certification is a material representation of fact upon which reliance is placed by the Federal government and that submission of this certification is a prerequisite for providing a Federal grant, loan (including a line of credit), cooperative agreement, loan guarantee, or loan insurance for a transaction covered by 31 U.S.C. 1352. The undersigned also understands that any person who fails to file a required certification shall be subject to a civil penalty of not less than \$10,000 and not more than \$100,000 for each such failure.

The (Vendor, Contractor) Rohrer Enterprises, Inc. DBA Rohrer Bus Sales, certifies or affirms the truthfulness and accuracy of each statement of its certification and disclosure, if any. In addition, the (Vendor, Contractor) understands and agrees that the provisions of 31 U.S.C. §§ 3801, et seq., apply to this certification and disclosure.

5/29/24
Date

Authorized Signature

Senior Vice President Sales
Title

REQUEST FOR QUOTATION
ADA Compliant Lowered Floor Mini-Van

BID FORM #9
REQUIRED BID FOR TO BE SUBMITTED WITH BID

CERTIFICATION OF RESTRICTIONS ON LOBBYING

The undersigned (Vendor, Contractor) certifies, to the best of his or her knowledge and belief, that:

1. No Federal appropriated funds have been paid or will be paid by or on behalf of the undersigned, to any person for influence or attempt to influence an officer or employee of any Federal agency, a Member of Congress, an officer or employee of Congress, or an employee of a Member of Congress regarding the award of a Federal grant, loan (including a line of credit), cooperative agreement, loan guarantee, or loan insurance, or the extension, continuation, renewal, amendment, or modification of any Federal grant, loan (including a line of credit), cooperative agreement, loan guarantee, or loan insurance.
2. If any funds other than Federal appropriated funds have been or will be paid to any person to influence or attempt to influence an officer or employee of any Federal agency, a Member of Congress, an officer or employee of Congress, or any employee of a Member of Congress in connection with any application for a Federal grant, loan (including a line of credit), cooperative agreement, loan guarantee, or loan insurance, the undersigned assures that it will complete and submit Standard Form-LLL, "Disclosure of Lobbying Activities," Rev. 7-97; and
3. The undersigned understands that the language of this certification shall be included in the award documents for all sub awards at all tiers (including subcontracts, sub grants, sub agreements, and contracts under grants, loans (including a line of credit), cooperative agreements, loan guarantees, and loan insurance.

Undersigned understands that this certification is a material representation of fact upon which reliance is placed by the Federal government and that submission of this certification is a prerequisite for providing a Federal grant, loan (including a line of credit), cooperative agreement, loan guarantee, or loan insurance for a transaction covered by 31 U.S.C. 1352. The undersigned also understands that any person who fails to file a required certification shall be subject to a civil penalty of not less than \$10,000 and not more than \$100,000 for each such failure.

The (Vendor, Contractor) The Braun Corporation, certifies or affirms the truthfulness and accuracy of each statement of its certification and disclosure, if any. In addition, the (Vendor, Contractor) understands and agrees that the provisions of 31 U.S.C. §§ 3801, et seq., apply to this certification and disclosure.

May 21, 2024

Date

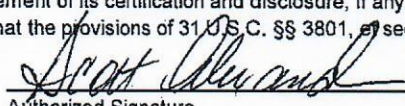
Authorized Signature

Scott Alexander, Associate Director, Commercial Inside Sales

Title

REQUEST FOR QUOTATION
ADA Compliant Lowered Floor Mini-Van

BID FORM #10

REQUIRED BID DOCUMENTATION CHECKLIST

Model Year: 2024 Model: Chrysler Voyager LX with BraunAbility Conversion

Mandatory Bid Forms – must be submitted with bid:

- Bid Form #1: Locations of Technical Service Representatives and Parts Distribution Centers
- Bid Form #2: Certification for Air & Water Pollution
- Bid Form #3: Disadvantaged Business Enterprise Vendors/Manufacturers Certification
- Bid Form #4: Buy America Certification Rolling Stock
- Bid Form #5: Federal Motor Vehicle Safety Standards Certification
- Bid Form #6: U.S. Comptroller's Debarment List Certification
- Bid Form #7: Certification of Primary Participant Regarding Debarment, Suspension, and Other Responsibility Matters
- Bid Form #8: Vendor's Certification of Understanding and Acceptance
- Bid Form #9: Certification of Restrictions on Lobbying
- Exhibit A Pricing Page

REQUEST FOR QUOTATION
ADA Compliant Lowered Floor Mini-Van

Documentation – to be submitted with bid:

Referenced

- ✓ 3.3.1.1 Engine: provide product description, warranty information and product literature.
- ✓ 3.6.1 Transmission: provide product description, warranty information and product literature.
- ✓ 3.6.4 Back Up Camera System: provide product description, warranty information and product literature.
- ✓ 3.11 Tires: provide product description, warranty information and product literature.
- ✓ 3.14.4 Undercoating and Rustproofing: provide product description, warranty information and literature.
- ✓ 3.14.7 Ambulatory Passenger Entrance/Exit: provide location, size, door operating details.
- ✓ 3.19.2 Floor Covering: provide samples of floor covering and colors to be provided.
- ✓ 3.22 Seating: provide product description, warranty information, product literature and color charts for all of the seating products to be utilized. Proposed floor plan.
- ✓ 3.2201 Driver's Seat: provide description of product.
- ✓ 3.27 Wheelchair Securement System: provide product description, warranty information and product literature.
- ✓ 3.28 Wheelchair Occupant Restraint System: provide product description, warranty information and product literature.
- ✓ 3.29 Wheelchair Ramp: provide Make, Model #, product description, warranty information and product literature.
- ✓ 3.35 Training: submit letter of understanding to the terms in this Section.

REQUEST FOR QUOTATION
ADA Compliant Lowered Floor Mini-Van

- 3.31.5 Security Camera: provide product description, warranty information and product literature.
- 5.9.1 Warranty on complete vehicle.
- 5.9.2 Warranty on Basic Vehicle Structure.
- 5.9.4 Warranty: warranties to be provided on subsystems and components.
- 10.2 A. Complete mechanical description of vehicle, its construction and equipment including manufacturer's model name and /or number. Include description of front and rear air conditioning and heat systems.
- 10.2 B Proposed interior floor plans, showing detailed dimensions including the location of the wheelchair securement system and stanchions.
- 10.2 C. Curb weight (empty weight) and gross vehicle weight rating (GVWR) of vehicle.
- 10.2 H. Identification of the conversion location of the van.
- 10.2 I. A list of five (5) users names, addresses, emails and telephone numbers who have been provided similar equipment by the Vendor.
- No Debt Affidavit
- Addendum Acknowledgement

STATE OF WEST VIRGINIA
Purchasing Division**PURCHASING AFFIDAVIT****VENDOR OWING A DEBT TO THE STATE:**

West Virginia Code §5A-3-10a provides that: No contract or renewal of any contract may be awarded by the state or any of its political subdivisions to any vendor or prospective vendor when the vendor or prospective vendor or a related party to the vendor or prospective vendor is a debtor and the debt owed is an amount greater than one thousand dollars in the aggregate.

PUBLIC IMPROVEMENT CONTRACTS & DRUG-FREE WORKPLACE ACT:

If this is a solicitation for a public improvement construction contract, the vendor, by its signature below, affirms that it has a written plan for a drug-free workplace policy in compliance with Article 1D, Chapter 21 of the **West Virginia Code**. The vendor **must** make said affirmation with its bid submission. Further, public improvement construction contract may not be awarded to a vendor who does not have a written plan for a drug-free workplace policy in compliance with Article 1D, Chapter 21 of the **West Virginia Code** and who has not submitted that plan to the appropriate contracting authority in timely fashion. For a vendor who is a subcontractor, compliance with Section 5, Article 1D, Chapter 21 of the **West Virginia Code** may take place before their work on the public improvement is begun.

ANTITRUST:

In submitting a bid to any agency for the state of West Virginia, the bidder offers and agrees that if the bid is accepted the bidder will convey, sell, assign or transfer to the state of West Virginia all rights, title and interest in and to all causes of action it may now or hereafter acquire under the antitrust laws of the United States and the state of West Virginia for price fixing and/or unreasonable restraints of trade relating to the particular commodities or services purchased or acquired by the state of West Virginia. Such assignment shall be made and become effective at the time the purchasing agency tenders the initial payment to the bidder.

I certify that this bid is made without prior understanding, agreement, or connection with any corporation, firm, limited liability company, partnership or person or entity submitting a bid for the same materials, supplies, equipment or services and is in all respects fair and without collusion or fraud. I further certify that I am authorized to sign the certification on behalf of the bidder or this bid.

LICENSING:

Vendors must be licensed and in good standing in accordance with any and all state and local laws and requirements by any state or local agency of West Virginia, including, but not limited to, the West Virginia Secretary of State's Office, the West Virginia Tax Department, West Virginia Insurance Commission, or any other state agencies or political subdivision. Furthermore, the vendor must provide all necessary releases to obtain information to enable the Director or spending unit to verify that the vendor is licensed and in good standing with the above entities.

CONFIDENTIALITY:

The vendor agrees that he or she will not disclose to anyone, directly or indirectly, any such personally identifiable information or other confidential information gained from the agency, unless the individual who is the subject of the information consents to the disclosure in writing or the disclosure is made pursuant to the agency's policies, procedures and rules. Vendor further agrees to comply with the Confidentiality Policies and Information Security Accountability Requirements, set forth in <http://www.state.wv.us/admin/purchase/privacy/noticeConfidentiality.pdf>.

Under penalty of law for false swearing (**West Virginia Code** §61-5-3), it is hereby certified that the vendor affirms and acknowledges the information in this affidavit and is in compliance with the requirements as stated.

Vendor's Name: Rohrer Enterprises, Inc. dba Rohrer Bus Sales

Authorized Signature:  Date: 5-29-24

STATE OF WEST VIRGINIA
Purchasing Division

PURCHASING AFFIDAVIT

CONSTRUCTION CONTRACTS: Under W. Va. Code § 5-22-1(i), the contracting public entity shall not award a construction contract to any bidder that is known to be in default on any monetary obligation owed to the state or a political subdivision of the state, including, but not limited to, obligations related to payroll taxes, property taxes, sales and use taxes, fire service fees, or other fines or fees.

ALL CONTRACTS: Under W. Va. Code §5A-3-10a, no contract or renewal of any contract may be awarded by the state or any of its political subdivisions to any vendor or prospective vendor when the vendor or prospective vendor or a related party to the vendor or prospective vendor is a debtor and: (1) the debt owed is an amount greater than one thousand dollars in the aggregate; or (2) the debtor is in employer default.

EXCEPTION: The prohibition listed above does not apply where a vendor has contested any tax administered pursuant to chapter eleven of the W. Va. Code, workers' compensation premium, permit fee or environmental fee or assessment and the matter has not become final or where the vendor has entered into a payment plan or agreement and the vendor is not in default of any of the provisions of such plan or agreement.

DEFINITIONS:

"Debt" means any assessment, premium, penalty, fine, tax or other amount of money owed to the state or any of its political subdivisions because of a judgment, fine, permit violation, license assessment, defaulted workers' compensation premium, penalty or other assessment presently delinquent or due and required to be paid to the state or any of its political subdivisions, including any interest or additional penalties accrued thereon.

"Employer default" means having an outstanding balance or liability to the old fund or to the uninsured employers' fund or being in policy default, as defined in W. Va. Code § 23-2c-2, failure to maintain mandatory workers' compensation coverage, or failure to fully meet its obligations as a workers' compensation self-insured employer. An employer is not in employer default if it has entered into a repayment agreement with the Insurance Commissioner and remains in compliance with the obligations under the repayment agreement.

"Related party" means a party, whether an individual, corporation, partnership, association, limited liability company or any other form or business association or other entity whatsoever, related to any vendor by blood, marriage, ownership or contract through which the party has a relationship of ownership or other interest with the vendor so that the party will actually or by effect receive or control a portion of the benefit, profit or other consideration from performance of a vendor contract with the party receiving an amount that meets or exceeds five percent of the total contract amount.

AFFIRMATION: By signing this form, the vendor's authorized signer affirms and acknowledges under penalty of law for false swearing (W. Va. Code §61-5-3) that: (1) for construction contracts, the vendor is not in default on any monetary obligation owed to the state or a political subdivision of the state, and (2) for all other contracts, that neither vendor nor any related party owe a debt as defined above and that neither vendor nor any related party are in employer default as defined above, unless the debt or employer default is permitted under the exception above.

WITNESS THE FOLLOWING SIGNATURE:

Vendor's Name: Rohrer Enterprises Inc. dba Rohrer Bus Sales

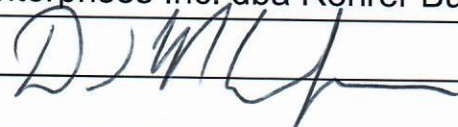
Authorized Signature:  Date: 5-29-24

State of Virginia

County of Augusta, to-wit:

Taken, subscribed, and sworn to before me this 29 day of May, 2024.

My Commission expires June, 30, 2026.

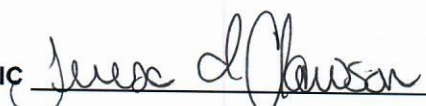

NOTARY PUBLIC 

REQUEST FOR QUOTATION
ADA Compliant Lowered Floor Minivans

18. MISCELLANEOUS:

- 18.1 No Substitutions:** Vendor shall supply only Vehicles as submitted in response to the Solicitation unless a contract modification is approved in accordance with the provisions contained in this Contract.
- 18.2 Vendor Supply:** Vendor must carry sufficient inventory of the Contract Items being offered to fulfill its obligations under this Contract. By signing its bid, Vendor certifies that it can supply the Contract Items contained in its bid response.
- 18.3 Contract Manager:** During its performance of this Contract, Vendor must designate and maintain a primary contract manager responsible for overseeing Vendor's responsibilities under this Contract. The Contract manager must be available during normal business hours to address any customer service or other issues related to this Contract. Vendor should list its Contract manager and his or her contact information below.

Contract Manager: David Clawson

Telephone Number: 540-729-3751

Fax Number: 717-957-4884

Email Address: dclawson@rohrcerbus.com

18.4 NOTIFICATION OF FEDERAL PARTICIPATION

Federal funding for this project is being provided by the Federal Transit Administration through various CFDA grants for 80% of the project cost. CFDA grants will be specified after award.



Department of Administration
 Purchasing Division
 2019 Washington Street East
 Post Office Box 50130
 Charleston, WV 25305-0130

State of West Virginia
 Centralized Request for Quote
 Vehicles

Proc Folder: 1387185

Doc Description: ADA Compliant Lowered Floor Minivans

Reason for Modification:

Proc Type: Central Master Agreement

Date Issued	Solicitation Closes	Solicitation No	Version
2024-04-18	2024-05-07 13:30	CRFQ 0810 DMT2400000006	1

BID RECEIVING LOCATION

BID CLERK
 DEPARTMENT OF ADMINISTRATION
 PURCHASING DIVISION
 2019 WASHINGTON ST E
 CHARLESTON WV 25305
 US

VENDOR

Vendor Customer Code: VS0000004719
 Vendor Name : Rohrer Enterprises, Inc. DBA Rohrer Bus Sales
 Address : 1515 State Road PO Box 100
 Street :
 City : Duncannon
 State : PA Country : USA Zip : 17020
 Principal Contact : David M Clawson, Senior Vice President Sales
 Vendor Contact Phone:800-735-3900/540-729-3751 Extension:

FOR INFORMATION CONTACT THE BUYER

John W Estep
 304-558-2566
 john.w.estep@wv.gov

Vendor
 Signature X

FEIN# 23-205997

DATE 5/28/24

All offers subject to all terms and conditions contained in this solicitation

ADDITIONAL INFORMATION**REQUEST FOR QUOTATION:**

The West Virginia Purchasing Division is soliciting bids on behalf of the Division of Multimodal Transportation Facilities -Public Transit (DMTF-PT); and any other agency that desires to utilize this contract, to establish an open-ended contract for Americans with Disabilities Act (ADA) Compliant Lowered Floor Min-Van(s). The offered vehicles would include wheelchair securements and a deployable ramp to provide transportation services in an urban/rural environment which includes mountainous terrain and a severe weather operating climate. The offered vehicle shall be capable to perform stop-start duty cycles. Per the Bid Requirements, Specifications, Terms and Conditions attached to this solicitation.

INVOICE TO**SHIP TO**

PUBLIC TRANSIT DIVISION
OF
BLDG 5 RM 663

1900 KANAWHA BLVD E
CHARLESTON WV
US

PUBLIC TRANSIT DIVISION
OF

KANAWHA VALLEY
REGIONAL
TRANSPORTATION
AUTHORITY

1550 FOURTH AVE
CHARLESTON
US

WV

Line	Comm Ln Desc	Qty	Unit Issue	Unit Price	Total Price
1	ADA Lowered Floor Minivans	10.00000	EA		

Comm Code	Manufacturer	Specification	Model #
25101502		2024 Chrysler Voyager LX with	Bravability Conversion

Extended Description:

To establish an open-ended contract for ADA Lowered Floor Minivans. These vehicles will not possess any graphics.

SCHEDULE OF EVENTS

Line	Event	Event Date
1	Tech Questions dur by 10:00am	2024-04-26

	Document Phase	Document Description	Page
DMT240000006	Final	ADA Compliant Lowered Floor Minivans	3 N/A

ADDITIONAL TERMS AND CONDITIONS

See attached document(s) for additional Terms and Conditions

GENERAL TERMS AND CONDITIONS:

1. CONTRACTUAL AGREEMENT: Issuance of an Award Document signed by the Purchasing Division Director, or his designee, and approved as to form by the Attorney General's office constitutes acceptance by the State of this Contract made by and between the State of West Virginia and the Vendor. Vendor's signature on its bid, or on the Contract if the Contract is not the result of a bid solicitation, signifies Vendor's agreement to be bound by and accept the terms and conditions contained in this Contract.

2. DEFINITIONS: As used in this Solicitation/Contract, the following terms shall have the meanings attributed to them below. Additional definitions may be found in the specifications included with this Solicitation/Contract.

2.1. "Agency" or "Agencies" means the agency, board, commission, or other entity of the State of West Virginia that is identified on the first page of the Solicitation or any other public entity seeking to procure goods or services under this Contract.

2.2. "Bid" or "Proposal" means the vendors submitted response to this solicitation.

2.3. "Contract" means the binding agreement that is entered into between the State and the Vendor to provide the goods or services requested in the Solicitation.

2.4. "Director" means the Director of the West Virginia Department of Administration, Purchasing Division.

2.5. "Purchasing Division" means the West Virginia Department of Administration, Purchasing Division.

2.6. "Award Document" means the document signed by the Agency and the Purchasing Division, and approved as to form by the Attorney General, that identifies the Vendor as the contract holder.

2.7. "Solicitation" means the official notice of an opportunity to supply the State with goods or services that is published by the Purchasing Division.

2.8. "State" means the State of West Virginia and/or any of its agencies, commissions, boards, etc. as context requires.

2.9. "Vendor" or "Vendors" means any entity submitting a bid in response to the Solicitation, the entity that has been selected as the lowest responsible bidder, or the entity that has been awarded the Contract as context requires.

3. CONTRACT TERM; RENEWAL; EXTENSION: The term of this Contract shall be determined in accordance with the category that has been identified as applicable to this Contract below:

Term Contract

Initial Contract Term: The Initial Contract Term will be for a period of (1) one year. The Initial Contract Term becomes effective on the effective start date listed on the first page of this Contract, identified as the State of West Virginia contract cover page containing the signatures of the Purchasing Division, Attorney General, and Encumbrance clerk (or another page identified as _____), and the Initial Contract Term ends on the effective end date also shown on the first page of this Contract.

Renewal Term: This Contract may be renewed upon the mutual written consent of the Agency, and the Vendor, with approval of the Purchasing Division and the Attorney General's office (Attorney General approval is as to form only). Any request for renewal should be delivered to the Agency and then submitted to the Purchasing Division thirty (30) days prior to the expiration date of the initial contract term or appropriate renewal term. A Contract renewal shall be in accordance with the terms and conditions of the original contract. Unless otherwise specified below, renewal of this Contract is limited to one successive one (1) year periods or multiple renewal periods of less than one year, provided that the multiple renewal periods do not exceed the total number of months available in all renewal years combined. Automatic renewal of this Contract is prohibited. Renewals must be approved by the Vendor, Agency, Purchasing Division and Attorney General's office (Attorney General approval is as to form only)

Alternate Renewal Term – This contract may be renewed for _____ successive _____ year periods or shorter periods provided that they do not exceed the total number of months contained in all available renewals. Automatic renewal of this Contract is prohibited. Renewals must be approved by the Vendor, Agency, Purchasing Division and Attorney General's office (Attorney General approval is as to form only)

Delivery Order Limitations: In the event that this contract permits delivery orders, a delivery order may only be issued during the time this Contract is in effect. Any delivery order issued within one year of the expiration of this Contract shall be effective for one year from the date the delivery order is issued. No delivery order may be extended beyond one year after this Contract has expired.

Fixed Period Contract: This Contract becomes effective upon Vendor's receipt of the notice to proceed and must be completed within _____ days.

Fixed Period Contract with Renewals: This Contract becomes effective upon Vendor's receipt of the notice to proceed and part of the Contract more fully described in the attached specifications must be completed within _____ days. Upon completion of the work covered by the preceding sentence, the vendor agrees that:

the contract will continue for _____ years;

the contract may be renewed for _____ successive _____ year periods or shorter periods provided that they do not exceed the total number of months contained in all available renewals. Automatic renewal of this Contract is prohibited. Renewals must be approved by the Vendor, Agency, Purchasing Division and Attorney General's Office (Attorney General approval is as to form only).

One-Time Purchase: The term of this Contract shall run from the issuance of the Award Document until all of the goods contracted for have been delivered, but in no event will this Contract extend for more than one fiscal year.

Construction/Project Oversight: This Contract becomes effective on the effective start date listed on the first page of this Contract, identified as the State of West Virginia contract cover page containing the signatures of the Purchasing Division, Attorney General, and Encumbrance clerk (or another page identified as _____), and continues until the project for which the vendor is providing oversight is complete.

Other: Contract Term specified in _____

4. AUTHORITY TO PROCEED: Vendor is authorized to begin performance of this contract on the date of encumbrance listed on the front page of the Award Document unless either the box for "Fixed Period Contract" or "Fixed Period Contract with Renewals" has been checked in Section 3 above. If either "Fixed Period Contract" or "Fixed Period Contract with Renewals" has been checked, Vendor must not begin work until it receives a separate notice to proceed from the State. The notice to proceed will then be incorporated into the Contract via change order to memorialize the official date that work commenced.

5. QUANTITIES: The quantities required under this Contract shall be determined in accordance with the category that has been identified as applicable to this Contract below.

Open End Contract: Quantities listed in this Solicitation/Award Document are approximations only, based on estimates supplied by the Agency. It is understood and agreed that the Contract shall cover the quantities actually ordered for delivery during the term of the Contract, whether more or less than the quantities shown.

Service: The scope of the service to be provided will be more clearly defined in the specifications included herewith.

Combined Service and Goods: The scope of the service and deliverable goods to be provided will be more clearly defined in the specifications included herewith.

One-Time Purchase: This Contract is for the purchase of a set quantity of goods that are identified in the specifications included herewith. Once those items have been delivered, no additional goods may be procured under this Contract without an appropriate change order approved by the Vendor, Agency, Purchasing Division, and Attorney General's office.

Construction: This Contract is for construction activity more fully defined in the specifications.

6. EMERGENCY PURCHASES: The Purchasing Division Director may authorize the Agency to purchase goods or services in the open market that Vendor would otherwise provide under this Contract if those goods or services are for immediate or expedited delivery in an emergency. Emergencies shall include, but are not limited to, delays in transportation or an unanticipated increase in the volume of work. An emergency purchase in the open market, approved by the Purchasing Division Director, shall not constitute of breach of this Contract and shall not entitle the Vendor to any form of compensation or damages. This provision does not excuse the State from fulfilling its obligations under a One-Time Purchase contract.

7. REQUIRED DOCUMENTS: All of the items checked in this section must be provided to the Purchasing Division by the Vendor as specified:

LICENSE(S) / CERTIFICATIONS / PERMITS: In addition to anything required under the Section of the General Terms and Conditions entitled Licensing, the apparent successful Vendor shall furnish proof of the following licenses, certifications, and/or permits upon request and in a form acceptable to the State. The request may be prior to or after contract award at the State's sole discretion.

The apparent successful Vendor shall also furnish proof of any additional licenses or certifications contained in the specifications regardless of whether or not that requirement is listed above.

8. INSURANCE: The apparent successful Vendor shall furnish proof of the insurance identified by a checkmark below prior to Contract award. The insurance coverages identified below must be maintained throughout the life of this contract. Thirty (30) days prior to the expiration of the insurance policies, Vendor shall provide the Agency with proof that the insurance mandated herein has been continued. Vendor must also provide Agency with immediate notice of any changes in its insurance policies, including but not limited to, policy cancelation, policy reduction, or change in insurers. The apparent successful Vendor shall also furnish proof of any additional insurance requirements contained in the specifications prior to Contract award regardless of whether that insurance requirement is listed in this section.

Vendor must maintain:

Commercial General Liability Insurance in at least an amount of: \$1000000.00 per occurrence.

Automobile Liability Insurance in at least an amount of: \$1000000.00 per occurrence.

Professional/Malpractice/Errors and Omission Insurance in at least an amount of: _____ per occurrence. Notwithstanding the forgoing, Vendor's are not required to list the State as an additional insured for this type of policy.

Commercial Crime and Third Party Fidelity Insurance in an amount of: _____ per occurrence.

Cyber Liability Insurance in an amount of: _____ per occurrence.

Builders Risk Insurance in an amount equal to 100% of the amount of the Contract.

Pollution Insurance in an amount of: _____ per occurrence.

Aircraft Liability in an amount of: _____ per occurrence.

9. WORKERS' COMPENSATION INSURANCE: Vendor shall comply with laws relating to workers compensation, shall maintain workers' compensation insurance when required, and shall furnish proof of workers' compensation insurance upon request.

10. VENUE: All legal actions for damages brought by Vendor against the State shall be brought in the West Virginia Claims Commission. Other causes of action must be brought in the West Virginia court authorized by statute to exercise jurisdiction over it.

11. LIQUIDATED DAMAGES: This clause shall in no way be considered exclusive and shall not limit the State or Agency's right to pursue any other available remedy. Vendor shall pay liquidated damages in the amount specified below or as described in the specifications:

_____ for _____.

Liquidated Damages Contained in the Specifications.

Liquidated Damages Are Not Included in this Contract.

12. ACCEPTANCE: Vendor's signature on its bid, or on the certification and signature page, constitutes an offer to the State that cannot be unilaterally withdrawn, signifies that the product or service proposed by vendor meets the mandatory requirements contained in the Solicitation for that product or service, unless otherwise indicated, and signifies acceptance of the terms and conditions contained in the Solicitation unless otherwise indicated.

13. PRICING: The pricing set forth herein is firm for the life of the Contract, unless specified elsewhere within this Solicitation/Contract by the State. A Vendor's inclusion of price adjustment provisions in its bid, without an express authorization from the State in the Solicitation to do so, may result in bid disqualification. Notwithstanding the foregoing, Vendor must extend any publicly advertised sale price to the State and invoice at the lower of the contract price or the publicly advertised sale price.

14. PAYMENT IN ARREARS: Payments for goods/services will be made in arrears only upon receipt of a proper invoice, detailing the goods/services provided or receipt of the goods/services, whichever is later. Notwithstanding the foregoing, payments for software maintenance, licenses, or subscriptions may be paid annually in advance.

15. PAYMENT METHODS: Vendor must accept payment by electronic funds transfer and P-Card. (The State of West Virginia's Purchasing Card program, administered under contract by a banking institution, processes payment for goods and services through state designated credit cards.)

16. TAXES: The Vendor shall pay any applicable sales, use, personal property or any other taxes arising out of this Contract and the transactions contemplated thereby. The State of West Virginia is exempt from federal and state taxes and will not pay or reimburse such taxes.

17. ADDITIONAL FEES: Vendor is not permitted to charge additional fees or assess additional charges that were not either expressly provided for in the solicitation published by the State of West Virginia, included in the Contract, or included in the unit price or lump sum bid amount that Vendor is required by the solicitation to provide. Including such fees or charges as notes to the solicitation may result in rejection of vendor's bid. Requesting such fees or charges be paid after the contract has been awarded may result in cancellation of the contract.

18. FUNDING: This Contract shall continue for the term stated herein, contingent upon funds being appropriated by the Legislature or otherwise being made available. In the event funds are not appropriated or otherwise made available, this Contract becomes void and of no effect beginning on July 1 of the fiscal year for which funding has not been appropriated or otherwise made available. If that occurs, the State may notify the Vendor that an alternative source of funding has been obtained and thereby avoid the automatic termination. Non-appropriation or non-funding shall not be considered an event of default.

19. CANCELLATION: The Purchasing Division Director reserves the right to cancel this Contract immediately upon written notice to the vendor if the materials or workmanship supplied do not conform to the specifications contained in the Contract. The Purchasing Division Director may also cancel any purchase or Contract upon 30 days written notice to the Vendor in accordance with West Virginia Code of State Rules § 148-1-5.2.b.

20. TIME: Time is of the essence regarding all matters of time and performance in this Contract.

21. APPLICABLE LAW: This Contract is governed by and interpreted under West Virginia law without giving effect to its choice of law principles. Any information provided in specification manuals, or any other source, verbal or written, which contradicts or violates the West Virginia Constitution, West Virginia Code, or West Virginia Code of State Rules is void and of no effect.

22. COMPLIANCE WITH LAWS: Vendor shall comply with all applicable federal, state, and local laws, regulations and ordinances. By submitting a bid, Vendor acknowledges that it has reviewed, understands, and will comply with all applicable laws, regulations, and ordinances.

SUBCONTRACTOR COMPLIANCE: Vendor shall notify all subcontractors providing commodities or services related to this Contract that as subcontractors, they too are required to comply with all applicable laws, regulations, and ordinances. Notification under this provision must occur prior to the performance of any work under the contract by the subcontractor.

23. ARBITRATION: Any references made to arbitration contained in this Contract, Vendor's bid, or in any American Institute of Architects documents pertaining to this Contract are hereby deleted, void, and of no effect.

24. MODIFICATIONS: This writing is the parties' final expression of intent. Notwithstanding anything contained in this Contract to the contrary no modification of this Contract shall be binding without mutual written consent of the Agency, and the Vendor, with approval of the Purchasing Division and the Attorney General's office (Attorney General approval is as to form only). Any change to existing contracts that adds work or changes contract cost, and were not included in the original contract, must be approved by the Purchasing Division and the Attorney General's Office (as to form) prior to the implementation of the change or commencement of work affected by the change.

25. WAIVER: The failure of either party to insist upon a strict performance of any of the terms or provision of this Contract, or to exercise any option, right, or remedy herein contained, shall not be construed as a waiver or a relinquishment for the future of such term, provision, option, right, or remedy, but the same shall continue in full force and effect. Any waiver must be expressly stated in writing and signed by the waiving party.

26. SUBSEQUENT FORMS: The terms and conditions contained in this Contract shall supersede any and all subsequent terms and conditions which may appear on any form documents submitted by Vendor to the Agency or Purchasing Division such as price lists, order forms, invoices, sales agreements, or maintenance agreements, and includes internet websites or other electronic documents. Acceptance or use of Vendor's forms does not constitute acceptance of the terms and conditions contained thereon.

27. ASSIGNMENT: Neither this Contract nor any monies due, or to become due hereunder, may be assigned by the Vendor without the express written consent of the Agency, the Purchasing Division, the Attorney General's office (as to form only), and any other government agency or office that may be required to approve such assignments.

28. WARRANTY: The Vendor expressly warrants that the goods and/or services covered by this Contract will: (a) conform to the specifications, drawings, samples, or other description furnished or specified by the Agency; (b) be merchantable and fit for the purpose intended; and (c) be free from defect in material and workmanship.

29. STATE EMPLOYEES: State employees are not permitted to utilize this Contract for personal use and the Vendor is prohibited from permitting or facilitating the same.

30. PRIVACY, SECURITY, AND CONFIDENTIALITY: The Vendor agrees that it will not disclose to anyone, directly or indirectly, any such personally identifiable information or other confidential information gained from the Agency, unless the individual who is the subject of the information consents to the disclosure in writing or the disclosure is made pursuant to the Agency's policies, procedures, and rules. Vendor further agrees to comply with the Confidentiality Policies and Information Security Accountability Requirements, set forth in www.state.wv.us/admin/purchase/privacy.

31. YOUR SUBMISSION IS A PUBLIC DOCUMENT: Vendor's entire response to the Solicitation and the resulting Contract are public documents. As public documents, they will be disclosed to the public following the bid/proposal opening or award of the contract, as required by the competitive bidding laws of West Virginia Code §§ 5A-3-1 et seq., 5-22-1 et seq., and 5G-1-1 et seq. and the Freedom of Information Act West Virginia Code §§ 29B-1-1 et seq.

DO NOT SUBMIT MATERIAL YOU CONSIDER TO BE CONFIDENTIAL, A TRADE SECRET, OR OTHERWISE NOT SUBJECT TO PUBLIC DISCLOSURE.

Submission of any bid, proposal, or other document to the Purchasing Division constitutes your explicit consent to the subsequent public disclosure of the bid, proposal, or document. The Purchasing Division will disclose any document labeled "confidential," "proprietary," "trade secret," "private," or labeled with any other claim against public disclosure of the documents, to include any "trade secrets" as defined by West Virginia Code § 47-22-1 et seq. All submissions are subject to public disclosure without notice.

32. LICENSING: In accordance with West Virginia Code of State Rules § 148-1-6.1.e, Vendor must be licensed and in good standing in accordance with any and all state and local laws and requirements by any state or local agency of West Virginia, including, but not limited to, the West Virginia Secretary of State's Office, the West Virginia Tax Department, West Virginia Insurance Commission, or any other state agency or political subdivision. Obligations related to political subdivisions may include, but are not limited to, business licensing, business and occupation taxes, inspection compliance, permitting, etc. Upon request, the Vendor must provide all necessary releases to obtain information to enable the Purchasing Division Director or the Agency to verify that the Vendor is licensed and in good standing with the above entities.

SUBCONTRACTOR COMPLIANCE: Vendor shall notify all subcontractors providing commodities or services related to this Contract that as subcontractors, they too are required to be licensed, in good standing, and up-to-date on all state and local obligations as described in this section. Obligations related to political subdivisions may include, but are not limited to, business licensing, business and occupation taxes, inspection compliance, permitting, etc. Notification under this provision must occur prior to the performance of any work under the contract by the subcontractor.

33. ANTITRUST: In submitting a bid to, signing a contract with, or accepting a Award Document from any agency of the State of West Virginia, the Vendor agrees to convey, sell, assign, or transfer to the State of West Virginia all rights, title, and interest in and to all causes of action it may now or hereafter acquire under the antitrust laws of the United States and the State of West Virginia for price fixing and/or unreasonable restraints of trade relating to the particular commodities or services purchased or acquired by the State of West Virginia. Such assignment shall be made and become effective at the time the purchasing agency tenders the initial payment to Vendor.

34. VENDOR NON-CONFLICT: Neither Vendor nor its representatives are permitted to have any interest, nor shall they acquire any interest, direct or indirect, which would compromise the performance of its services hereunder. Any such interests shall be promptly presented in detail to the Agency.

35. VENDOR RELATIONSHIP: The relationship of the Vendor to the State shall be that of an independent contractor and no principal-agent relationship or employer-employee relationship is contemplated or created by this Contract. The Vendor as an independent contractor is solely liable for the acts and omissions of its employees and agents. Vendor shall be responsible for selecting, supervising, and compensating any and all individuals employed pursuant to the terms of this Solicitation and resulting contract. Neither the Vendor, nor any employees or subcontractors of the Vendor, shall be deemed to be employees of the State for any purpose whatsoever. Vendor shall be exclusively responsible for payment of employees and contractors for all wages and salaries, taxes, withholding payments, penalties, fees, fringe benefits, professional liability insurance premiums, contributions to insurance and pension, or other deferred compensation plans, including but not limited to, Workers' Compensation and Social Security obligations, licensing fees, etc. and the filing of all necessary documents, forms, and returns pertinent to all of the foregoing.

Vendor shall hold harmless the State, and shall provide the State and Agency with a defense against any and all claims including, but not limited to, the foregoing payments, withholdings, contributions, taxes, Social Security taxes, and employer income tax returns.

36. INDEMNIFICATION: The Vendor agrees to indemnify, defend, and hold harmless the State and the Agency, their officers, and employees from and against: (1) Any claims or losses for services rendered by any subcontractor, person, or firm performing or supplying services, materials, or supplies in connection with the performance of the Contract; (2) Any claims or losses resulting to any person or entity injured or damaged by the Vendor, its officers, employees, or subcontractors by the publication, translation, reproduction, delivery, performance, use, or disposition of any data used under the Contract in a manner not authorized by the Contract, or by Federal or State statutes or regulations; and (3) Any failure of the Vendor, its officers, employees, or subcontractors to observe State and Federal laws including, but not limited to, labor and wage and hour laws.

37. NO DEBT CERTIFICATION: In accordance with West Virginia Code §§ 5A-3-10a and 5-22-1(i), the State is prohibited from awarding a contract to any bidder that owes a debt to the State or a political subdivision of the State. By submitting a bid, or entering into a contract with the State, Vendor is affirming that (1) for construction contracts, the Vendor is not in default on any monetary obligation owed to the state or a political subdivision of the state, and (2) for all other contracts, neither the Vendor nor any related party owe a debt as defined above, and neither the Vendor nor any related party are in employer default as defined in the statute cited above unless the debt or employer default is permitted under the statute.

38. CONFLICT OF INTEREST: Vendor, its officers or members or employees, shall not presently have or acquire an interest, direct or indirect, which would conflict with or compromise the performance of its obligations hereunder. Vendor shall periodically inquire of its officers, members and employees to ensure that a conflict of interest does not arise. Any conflict of interest discovered shall be promptly presented in detail to the Agency.

39. REPORTS: Vendor shall provide the Agency and/or the Purchasing Division with the following reports identified by a checked box below:

Such reports as the Agency and/or the Purchasing Division may request. Requested reports may include, but are not limited to, quantities purchased, agencies utilizing the contract, total contract expenditures by agency, etc.

Quarterly reports detailing the total quantity of purchases in units and dollars, along with a listing of purchases by agency. Quarterly reports should be delivered to the Purchasing Division via email at purchasing.division@wv.gov.

40. BACKGROUND CHECK: In accordance with W. Va. Code § 15-2D-3, the State reserves the right to prohibit a service provider's employees from accessing sensitive or critical information or to be present at the Capitol complex based upon results addressed from a criminal background check. Service providers should contact the West Virginia Division of Protective Services by phone at (304) 558-9911 for more information.

41. PREFERENCE FOR USE OF DOMESTIC STEEL PRODUCTS: Except when authorized by the Director of the Purchasing Division pursuant to W. Va. Code § 5A-3-56, no contractor may use or supply steel products for a State Contract Project other than those steel products made in the United States. A contractor who uses steel products in violation of this section may be subject to civil penalties pursuant to W. Va. Code § 5A-3-56. As used in this section:

- a. "State Contract Project" means any erection or construction of, or any addition to, alteration of or other improvement to any building or structure, including, but not limited to, roads or highways, or the installation of any heating or cooling or ventilating plants or other equipment, or the supply of and materials for such projects, pursuant to a contract with the State of West Virginia for which bids were solicited on or after June 6, 2001.
- b. "Steel Products" means products rolled, formed, shaped, drawn, extruded, forged, cast, fabricated or otherwise similarly processed, or processed by a combination of two or more or such operations, from steel made by the open heath, basic oxygen, electric furnace, Bessemer or other steel making process.
- c. The Purchasing Division Director may, in writing, authorize the use of foreign steel products if:
 1. The cost for each contract item used does not exceed one tenth of one percent (.1%) of the total contract cost or two thousand five hundred dollars (\$2,500.00), whichever is greater. For the purposes of this section, the cost is the value of the steel product as delivered to the project; or
 2. The Director of the Purchasing Division determines that specified steel materials are not produced in the United States in sufficient quantity or otherwise are not reasonably available to meet contract requirements.

42. PREFERENCE FOR USE OF DOMESTIC ALUMINUM, GLASS, AND STEEL: In Accordance with W. Va. Code § 5-19-1 et seq., and W. Va. CSR § 148-10-1 et seq., for every contract or subcontract, subject to the limitations contained herein, for the construction, reconstruction, alteration, repair, improvement or maintenance of public works or for the purchase of any item of machinery or equipment to be used at sites of public works, only domestic aluminum, glass or steel products shall be supplied unless the spending officer determines, in writing, after the receipt of offers or bids, (1) that the cost of domestic aluminum, glass or steel products is unreasonable or inconsistent with the public interest of the State of West Virginia, (2) that domestic aluminum, glass or steel products are not produced in sufficient quantities to meet the contract requirements, or (3) the available domestic aluminum, glass, or steel do not meet the contract specifications. This provision only applies to public works contracts awarded in an amount more than fifty thousand dollars (\$50,000) or public works contracts that require more than ten thousand pounds of steel products.

The cost of domestic aluminum, glass, or steel products may be unreasonable if the cost is more than twenty percent (20%) of the bid or offered price for foreign made aluminum, glass, or steel products. If the domestic aluminum, glass or steel products to be supplied or produced in a “substantial labor surplus area”, as defined by the United States Department of Labor, the cost of domestic aluminum, glass, or steel products may be unreasonable if the cost is more than thirty percent (30%) of the bid or offered price for foreign made aluminum, glass, or steel products. This preference shall be applied to an item of machinery or equipment, as indicated above, when the item is a single unit of equipment or machinery manufactured primarily of aluminum, glass or steel, is part of a public works contract and has the sole purpose or of being a permanent part of a single public works project. This provision does not apply to equipment or machinery purchased by a spending unit for use by that spending unit and not as part of a single public works project.

All bids and offers including domestic aluminum, glass or steel products that exceed bid or offer prices including foreign aluminum, glass or steel products after application of the preferences provided in this provision may be reduced to a price equal to or lower than the lowest bid or offer price for foreign aluminum, glass or steel products plus the applicable preference. If the reduced bid or offer prices are made in writing and supersede the prior bid or offer prices, all bids or offers, including the reduced bid or offer prices, will be reevaluated in accordance with this rule.

43. INTERESTED PARTY SUPPLEMENTAL DISCLOSURE: W. Va. Code § 6D-1-2 requires that for contracts with an actual or estimated value of at least \$1 million, the Vendor must submit to the Agency a disclosure of interested parties prior to beginning work under this Contract. Additionally, the Vendor must submit a supplemental disclosure of interested parties reflecting any new or differing interested parties to the contract, which were not included in the original pre-work interested party disclosure, within 30 days following the completion or termination of the contract. A copy of that form is included with this solicitation or can be obtained from the WV Ethics Commission. This requirement does not apply to publicly traded companies listed on a national or international stock exchange. A more detailed definition of interested parties can be obtained from the form referenced above.

44. PROHIBITION AGAINST USED OR REFURBISHED: Unless expressly permitted in the solicitation published by the State, Vendor must provide new, unused commodities, and is prohibited from supplying used or refurbished commodities, in fulfilling its responsibilities under this Contract.

45. VOID CONTRACT CLAUSES: This Contract is subject to the provisions of West Virginia Code § 5A-3-62, which automatically voids certain contract clauses that violate State law.

46. ISRAEL BOYCOTT: Bidder understands and agrees that, pursuant to W. Va. Code § 5A-3-63, it is prohibited from engaging in a boycott of Israel during the term of this contract.

DESIGNATED CONTACT: Vendor appoints the individual identified in this Section as the Contract Administrator and the initial point of contact for matters relating to this Contract.

(Printed Name and Title) David M Clawson, Senior Vice President Sales

(Address) 1515 State Road PO Box 100 Duncannon PA 17020

(Phone Number) / (Fax Number) 800-735-3900/540-729-3751

(email address) dclawson@rohrerbus.com

CERTIFICATION AND SIGNATURE: By signing below, or submitting documentation through wvOASIS, I certify that: I have reviewed this Solicitation/Contract in its entirety; that I understand the requirements, terms and conditions, and other information contained herein; that this bid, offer or proposal constitutes an offer to the State that cannot be unilaterally withdrawn; that the product or service proposed meets the mandatory requirements contained in the Solicitation/Contract for that product or service, unless otherwise stated herein; that the Vendor accepts the terms and conditions contained in the Solicitation, unless otherwise stated herein; that I am submitting this bid, offer or proposal for review and consideration; that this bid or offer was made without prior understanding, agreement, or connection with any entity submitting a bid or offer for the same material, supplies, equipment or services; that this bid or offer is in all respects fair and without collusion or fraud; that this Contract is accepted or entered into without any prior understanding, agreement, or connection to any other entity that could be considered a violation of law; that I am authorized by the Vendor to execute and submit this bid, offer, or proposal, or any documents related thereto on Vendor's behalf; that I am authorized to bind the vendor in a contractual relationship; and that to the best of my knowledge, the vendor has properly registered with any State agency that may require registration.

By signing below, I further certify that I understand this Contract is subject to the provisions of West Virginia Code § 5A-3-62, which automatically voids certain contract clauses that violate State law; and that pursuant to W. Va. Code 5A-3-63, the entity entering into this contract is prohibited from engaging in a boycott against Israel.

Rohrer Enterprises, Inc. DBA Rohrer Bus Sales

(Company)

(Signature of Authorized Representative)

David M Clawson, Senior Vice President Sales

(Printed Name and Title of Authorized Representative) (Date)

800-735-3900/540-729-3751

(Phone Number) (Fax Number)

dclawson@rohrerbus.com

(Email Address)



Department of Administration
 Purchasing Division
 2019 Washington Street East
 Post Office Box 50130
 Charleston, WV 25305-0130

State of West Virginia
 Centralized Request for Quote
 Vehicles

Proc Folder: 1387185		Reason for Modification: ADDENDUM NO_1 Bid Opening moves to 05/30/2024 @ 1:30pm
Doc Description: ADA Compliant Lowered Floor Minivans		
Proc Type: Central Master Agreement		
Date Issued	Solicitation Closes	Solicitation No
2024-04-18	2024-05-07 13:30	CRFQ 0810 DMT2400000006
		Version 2

BID RECEIVING LOCATION

BID CLERK
 DEPARTMENT OF ADMINISTRATION
 PURCHASING DIVISION
 2019 WASHINGTON ST E
 CHARLESTON WV 25305
 US

VENDOR

Vendor Customer Code: VS0000004719
Vendor Name : Rohrer Enterprises, Inc. DBA Rohrer Bus Sales
Address : 1515 State Road PO Box 100
Street :
City : Duncannon
State : PA **Country :** USA **Zip :** 17020
Principal Contact : David M Clawson, Senior Vice President Sales
Vendor Contact Phone: 540-729-3751 **Extension:**

FOR INFORMATION CONTACT THE BUYER
 John W Estep
 304-558-2566
 john.w.estep@wv.gov

Vendor Signature X 

FEIN# 23-205997 **DATE** 5/29/24

All offers subject to all terms and conditions contained in this solicitation

ADDITIONAL INFORMATION

ADDENDUM NO_1

Addendum No_1 issued to publish and distribute the attached information to the Vendor Community

REQUEST FOR QUOTATION:

The West Virginia Purchasing Division is soliciting bids on behalf of the Division of Multimodal Transportation Facilities -Public Transit (DMTF-PT); and any other agency that desires to utilize this contract, to establish an open-ended contract for Americans with Disabilities Act (ADA) Compliant Lowered Floor Min-Van(s). The offered vehicles would include wheelchair securements and a deployable ramp to provide transportation services in an urban/rural environment which includes mountainous terrain and a severe weather operating climate. The offered vehicle shall be capable to perform stop-start duty cycles. Per the Bid Requirements, Specifications, Terms and Conditions attached to this solicitation.

INVOICE TO
 PUBLIC TRANSIT DIVISION
 OF
 BLDG 5 RM 663

 1900 KANAWHA BLVD E
 CHARLESTON WV
 US
SHIP TO
 PUBLIC TRANSIT DIVISION
 OF
 KANAWHA VALLEY
 REGIONAL
 TRANSPORTATION
 AUTHORITY
 1550 FOURTH AVE
 CHARLESTON WV
 US

Line	Comm Ln Desc	Qty	Unit Issue	Unit Price	Total Price
1	ADA Lowered Floor Minivans	10.00000	EA		

Comm Code	Manufacturer	Specification	Model #
25101502			

Extended Description:

To establish an open-ended contract for ADA Lowered Floor Minivans. These vehicles will not possess any graphics.

SCHEDULE OF EVENTS

Line	Event	Event Date
1	Tech Questions dur by 10:00am	2024-04-26

SOLICITATION NUMBER: CRFQ DMT2400000006

Addendum Number: 1

The purpose of this addendum is to modify the solicitation identified as CRFQ DMT2400000006 (“Solicitation”) to reflect the change(s) identified and described below.

Applicable Addendum Category:

- [X] Modify bid opening date and time
- [] Modify specifications of product or service being sought
- [X] Attachment of vendor questions and responses
- [] Attachment of pre-bid sign-in sheet
- [] Correction of error
- [] Other

Additional Documentation:

Bid Opening Moves to 05/30/2024 at 1:30pm

Terms and Conditions:

1. All provisions of the Solicitation and other addenda not modified herein shall remain in full force and effect.
2. Vendor should acknowledge receipt of all addenda issued for this Solicitation by completing an Addendum Acknowledgment, a copy of which is included herewith. Failure to acknowledge addenda may result in bid disqualification. The addendum acknowledgement should be submitted with the bid to expedite document processing.

ADDENDUM ACKNOWLEDGEMENT FORM
SOLICITATION NO.: CRFQ DMT240000006

Instructions: Please acknowledge receipt of all addenda issued with this solicitation by completing this addendum acknowledgment form. Check the box next to each addendum received and sign below. Failure to acknowledge addenda may result in bid disqualification.

Acknowledgment: I hereby acknowledge receipt of the following addenda and have made the necessary revisions to my proposal, plans and/or specification, etc.

Addendum Numbers Received:

(Check the box next to each addendum received)

- | | |
|--|--|
| <input checked="" type="checkbox"/> Addendum No. 1 | <input type="checkbox"/> Addendum No. 6 |
| <input type="checkbox"/> Addendum No. 2 | <input type="checkbox"/> Addendum No. 7 |
| <input type="checkbox"/> Addendum No. 3 | <input type="checkbox"/> Addendum No. 8 |
| <input type="checkbox"/> Addendum No. 4 | <input type="checkbox"/> Addendum No. 9 |
| <input type="checkbox"/> Addendum No. 5 | <input type="checkbox"/> Addendum No. 10 |

I understand that failure to confirm the receipt of addenda may be cause for rejection of this bid. I further understand that that any verbal representation made or assumed to be made during any oral discussion held between Vendor's representatives and any state personnel is not binding. Only the information issued in writing and added to the specifications by an official addendum is binding.

Rohrer Enterprises, Inc. DBA Rohrer Bus Sales

Company



Authorized Signature

5/29/24

Date

NOTE: This addendum acknowledgement should be submitted with the bid to expedite document processing.



Department of Administration
 Purchasing Division
 2019 Washington Street East
 Post Office Box 50130
 Charleston, WV 25305-0130

State of West Virginia
 Centralized Request for Quote
 Vehicles

Proc Folder: 1387185

Doc Description: ADA Compliant Lowered Floor Minivans

Reason for Modification:

ADDENDUM NO_2
 Attach Modified Specifications
 and New Exhibit A Pricing Page

Proc Type: Central Master Agreement

Date Issued	Solicitation Closes	Solicitation No	Version
2024-04-29	2024-05-30 13:30	CRFQ 0810 DMT2400000006	3

BID RECEIVING LOCATION

BID CLERK
 DEPARTMENT OF ADMINISTRATION
 PURCHASING DIVISION
 2019 WASHINGTON ST E
 CHARLESTON WV 25305
 US

VENDOR

Vendor Customer Code: VS0000004719

Vendor Name : Rohrer Enterprises, Inc. DBA Rohrer Bus Sales

Address : 1515 State Road PO Box 100

Street :

City :Duncannon

State : PA

Country : USA

Zip : 17020

Principal Contact : David M Clawson, Senior Vice President Sales

Vendor Contact Phone: 540-729-3751

Extension:

FOR INFORMATION CONTACT THE BUYER

John W Estep
 304-558-2566
 john.w.estep@wv.gov

Vendor
 Signature X

FEIN# 23-205997

DATE 5/29/24

All offers subject to all terms and conditions contained in this solicitation

ADDITIONAL INFORMATION

ADDENDUM NO_2

Addendum No_2 issued to publish and distribute the attached information to the Vendor Community

REQUEST FOR QUOTATION:

The West Virginia Purchasing Division is soliciting bids on behalf of the Division of Multimodal Transportation Facilities -Public Transit (DMTF-PT); and any other agency that desires to utilize this contract, to establish an open-ended contract for Americans with Disabilities Act (ADA) Compliant Lowered Floor Min-Van(s). The offered vehicles would include wheelchair securements and a deployable ramp to provide transportation services in an urban/rural environment which includes mountainous terrain and a severe weather operating climate. The offered vehicle shall be capable to perform stop-start duty cycles. Per the Bid Requirements, Specifications, Terms and Conditions attached to this solicitation.

INVOICE TO
 PUBLIC TRANSIT DIVISION
 OF
 BLDG 5 RM 663

 1900 KANAWHA BLVD E
 CHARLESTON WV
 US
SHIP TO
 PUBLIC TRANSIT DIVISION
 OF
 KANAWHA VALLEY
 REGIONAL
 TRANSPORTATION
 AUTHORITY
 1550 FOURTH AVE
 CHARLESTON WV
 US

Line	Comm Ln Desc	Qty	Unit Issue	Unit Price	Total Price
1	ADA Lowered Floor Minivans	10.00000	EA		

Comm Code	Manufacturer	Specification	Model #
25101502			

Extended Description:

To establish an open-ended contract for ADA Lowered Floor Minivans. These vehicles will not possess any graphics.

SCHEDULE OF EVENTS

Line	Event	Event Date
1	Tech Questions dur by 10:00am	2024-04-26

SOLICITATION NUMBER: CRFQ DMT2400000006

Addendum Number: 2

The purpose of this addendum is to modify the solicitation identified as CRFQ DMT2400000006 (“Solicitation”) to reflect the change(s) identified and described below.

Applicable Addendum Category:

- Modify bid opening date and time
- Modify specifications of product or service being sought
- Attachment of vendor questions and responses
- Attachment of pre-bid sign-in sheet
- Correction of error
- Other

Additional Documentation:

Attach Modified Specifications and New Exhibit A Pricing Page

Bid Opening remains 05/30/2024 at 1:30pm

Terms and Conditions:

1. All provisions of the Solicitation and other addenda not modified herein shall remain in full force and effect.
2. Vendor should acknowledge receipt of all addenda issued for this Solicitation by completing an Addendum Acknowledgment, a copy of which is included herewith. Failure to acknowledge addenda may result in bid disqualification. The addendum acknowledgement should be submitted with the bid to expedite document processing.

ADDENDUM ACKNOWLEDGEMENT FORM
SOLICITATION NO.: CRFQ DMT2400000006

Instructions: Please acknowledge receipt of all addenda issued with this solicitation by completing this addendum acknowledgment form. Check the box next to each addendum received and sign below. Failure to acknowledge addenda may result in bid disqualification.

Acknowledgment: I hereby acknowledge receipt of the following addenda and have made the necessary revisions to my proposal, plans and/or specification, etc.

Addendum Numbers Received:

(Check the box next to each addendum received)

- | | |
|--|--|
| <input type="checkbox"/> Addendum No. 1 | <input type="checkbox"/> Addendum No. 6 |
| <input checked="" type="checkbox"/> Addendum No. 2 | <input type="checkbox"/> Addendum No. 7 |
| <input type="checkbox"/> Addendum No. 3 | <input type="checkbox"/> Addendum No. 8 |
| <input type="checkbox"/> Addendum No. 4 | <input type="checkbox"/> Addendum No. 9 |
| <input type="checkbox"/> Addendum No. 5 | <input type="checkbox"/> Addendum No. 10 |

I understand that failure to confirm the receipt of addenda may be cause for rejection of this bid. I further understand that that any verbal representation made or assumed to be made during any oral discussion held between Vendor's representatives and any state personnel is not binding. Only the information issued in writing and added to the specifications by an official addendum is binding.

Rohrer Enterprises, Inc. DBA Rohrer Bus Sales

Company

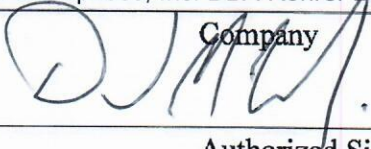

Authorized Signature

5/29/24

Date

NOTE: This addendum acknowledgment should be submitted with the bid to expedite document processing.

REQUEST FOR QUOTATION
ADA Compliant Lowered Floor Minivans

SPECIFICATIONS

1. **PURPOSE AND SCOPE:** The West Virginia Purchasing Division is soliciting bids on behalf of the Division of Multimodal Transportation Facilities -Public Transit (DMTF-PT); and any other agency that desires to utilize this contract, to establish an open-ended contract for American's with Disabilities Act (ADA) Compliant Lowered Floor Min-Van(s). The offered vehicles would include wheelchair securements and a deployable ramp to provide transportation services in an urban/rural environment which includes mountainous terrain and a severe weather operating climate. The offered vehicle shall be capable to perform stop-start duty cycles.

Vehicles supplied shall conform in all respects to the applicable Motor Vehicle Laws of the State of West Virginia, Federal Motor Vehicle Safety Standards, Environmental Protection Agency, Federal and State Regulations in effect at the time of manufacture and all must be in compliance with ADA regulations at the time production of the vehicle commences.

The Vendor is to deliver a new (current year) vehicle in one of proposed floor plans as defined in these specifications with different configurations identified as Class on the Exhibit A Pricing Pages, ready for operation. All required Federal Transit Administration's certification forms must be included in the bid proposal.

2. **DEFINITIONS:** The terms listed below shall have the meanings assigned to them below. Additional definitions can be found in section 2 of the General Terms and Conditions.
- 2.1 "ADA" means Americans with Disabilities Act of 1990 including applicable federal regulations issued pursuant to the Act in effect at the time production of the vehicle commences.
- 2.2 "ASTM" means American Society for Testing and Materials.
- 2.3 "Contract Item" or "Contract Items" means the list of items identified in Section 3.1 below and on the Pricing Pages.
- 2.4 "Curb Weight" means weight of the vehicle including maximum fuel, oil, and coolant and all equipment required for the operation as required by this specification without passengers or driver.
- 2.5 "DBA" means the decibel scale A weight to measure upper middle frequencies over time that can impact hearing loss.
- 2.6 "Division" means the West Virginia Division of Multimodal Transportation Facilities - Public Transit.
- 2.7 "DMV" means Division of Motor Vehicles State of West Virginia.

REQUEST FOR QUOTATION
ADA Compliant Lowered Floor Minivans

- 2.8 **"EPA"** means Environmental Protection Agency.
- 2.9 **"Fire Resistant"** means Materials that have a flame-spread index less than 150 as measured in a radiant panel flame test per ASTM 162-75.
- 2.10 **"Fireproof"** means materials that will not burn or melt at temperatures less than 2,000 degrees Fahrenheit.
- 2.11 **"FMVSS"** means Federal Motor Vehicle Safety Standards.
- 2.12 **"FTA"** means Federal Transit Administration.
- 2.13 **"GAWR FR"** is the maximum distributed weight that may be supported by the front axle.
- 2.14 **"GAWR RR"** is the maximum distributed weight that may be supported by the rear axle.
- 2.15 **"Gross Load"** means one hundred and seventy-five (175) pounds for every design passenger seating position and for the driver and three hundred (300) pounds for every wheelchair station. Vehicles will be operated without standees.
- 2.16 **"Gross Vehicle Weight Rating (GVWR)"** means the maximum loaded weight (including curb weight, operator & passenger weight, and payload) in pounds (lbs.) of a single vehicle. Vehicle manufacturers specify the maximum GVWR on the vehicle certification label.
- 2.17 **"HP"** means the power of an engine measured in terms of a unit of power equal to 550-foot pounds per second.
- 2.18 **"Manufacturer/Brand"** means the name of the maker of the contract item which will be supplied by the vendor.
- 2.19 **"Model & Number"** means the model's name and model number associated with the contract item as defined by the manufacturer.
- 2.20 **"OEM"** means Original Equipment Manufacturer.
- 2.21 **"Powertrain"** means the group of components used to transmit engine power to the wheels. The powertrain includes the engine, clutch, transmission, universal joints, drive shaft, and rear-axle gears.
- 2.22 **"Pricing Page"** means the pages, contained in wvOASIS, or attached as Exhibit A, upon which Vendor should list its proposed price for the Contract Items.
- 2.23 **"QVM"** means Qualified Vehicle Manufacturer.
- 2.24 **"RPM"** means Revolutions per minute.

REQUEST FOR QUOTATION
ADA Compliant Lowered Floor Minivans

- 2.25 "SAE" means Society of Automotive Engineers.
- 2.26 "Solicitation" means the official notice of an opportunity to supply the State with goods or services that is published by the Purchasing Division.
- 2.27 "Vendor Name" means the company name of the vendor who will be supplying the contract item(s) to the Division.
- 2.28 "Warranty" means the written guarantee issued with new motor vehicles or related equipment. It defines the manufacturer's responsibility for the repair or replacement of defective parts and other services provided as part of the purchase price. A warranty can be nullified if the user does not follow certain stipulations of the manufacturer, such as preventive maintenance.
- 2.29 "Wheelbase" means the distance from the centerline of the front axle to the centerline of the rear axle. Minimum of 121".
- 2.30 "NTSA" means National Highway Traffic Safety Administration.
- 2.31 "DOT" means Department of Transportation.
- 2.32 "LED" means Light-Emitting Diode.

3. GENERAL REQUIREMENTS:

- 3.1 **Contract Items and Mandatory Requirements:** Vendor shall provide Division with the Contract Items listed below on an open-end and continuing basis. Contract Items shall meet or exceed the mandatory requirements as shown below.
 - 3.1.1 In all cases, materials shall be furnished as specified Where brand names or specific items or processes are used in the specification, consider the term or equal to follow.
 - 3.1.1.1 **Legal Requirements.** The vehicle shall meet all applicable FMVSS, DMV and ADA, federal and state regulations in effect at the date of manufacture. Vendor shall supply certification that vehicle meets all FMVSS Regulations, and that vehicle complies with all relevant federal and State of West Virginia Standards at the time of delivery.
 - 3.1.1.2 **Components, Materials, Workmanship and Completeness.** These specifications reflect the Division's preference as to dimensions, materials, and major components. However, the vendor shall not omit any part of detail which goes to make the vehicle complete and

REQUEST FOR QUOTATION
ADA Compliant Lowered Floor Minivans

ready for service, even though such part or detail is not mentioned in these specifications.

- 3.1.1.3 All units or parts shall be manufacturer's best quality and shall conform in material, design and workmanship to the best practice known in the automotive industry. All parts shall be new and in no case will used, reconditioned, or obsolete parts be accepted. The parts on all vehicles provided by the same manufacturer shall be interchangeable.
- 3.1.1.4 The price quoted in any proposal submitted shall include all items of labor, material, tools, equipment, and other costs necessary to fully complete the manufacture and delivery of the vehicle pursuant to these specifications.
- 3.1.1.5 It is the intent of these specifications to provide and require a complete vehicle of the type prescribed ready for operation. The vendor shall assume sole responsibility for the entire vehicle as to warranty and after-sale parts and service.
- 3.1.1.6 Warranty to become effective on the first day, after the date of final acceptance, of each vehicle by the Division.
- 3.1.1.7 **Exhaust Emission Control Requirements.** The vehicle shall comply with all federal and state requirements applicable to the year of manufacture.

Regulations for Emission from Vehicles and Engines

- 3.1.1.8 **Noise Control.** The exterior noise from the vehicle shall not exceed eighty-six (86) dba using the procedures set forth in the SAE Standard SAE J366. Vendor shall supply report showing testing results of noise control. The interior noise at a location (2) feet from the rear window and four (4) feet from the floor shall not exceed eighty-six (86) dba with the vehicle standing with the transmission in neutral and the engine operating at a maximum rated RPM.
- 3.1.1.9 Body shall be thoroughly water tested and made tight to prevent leakage. All vehicles purchased under this contract shall, during the course of the manufacture and prior to acceptance, shall be subjected to a water test to

REQUEST FOR QUOTATION
ADA Compliant Lowered Floor Minivans

determine body leaks. This test shall consist of a series of nozzles, which are strategically located around the perimeter of the vehicle as to spray water over the entire surface of the vehicle. The nozzles shall eject a volume of water no less than twenty-two (22) pounds per square inch measured at the nozzle tip. Body shall be thoroughly water tested and made tight to prevent leakage. The bidder shall provide the procuring agency with details of its water testing procedures with the bid.

THE PRICING AND TERMS AND CONDITIONS OF THE BID MAY BE EXTENDED TO WEST VIRGINIA TRANSIT AUTHORITIES AND PRIVATE NON-PROFIT ORGANIZATIONS. IF VENDOR DOES NOT AGREE, VENDOR MUST CLEARLY INDICATE A REFUSAL IN HIS/HER BID.

3.2 CHASSIS

- 3.2.1** Chassis shall be current Model year Chrysler Voyager or equivalent meeting the following specifications and accepted industry standards.

3.3 ENGINE / EXHAUST SYSTEM

- 3.3.1** The vehicle shall be equipped with a gasoline engine with a displacement of at least 3.0 liters and no more than 4.0 liters providing between 280 – 300 horsepower with the operating fuel expenditure being between 15-21 City and 24-30 Highway miles per gallon.

Vendor shall submit product description, warranty information, and product literature with bid.

The engine shall be installed to produce a minimum of vibration. A firewall of sandwich construction shall separate the engine and passenger compartments, providing both thermal and acoustic insulation and sealing against intrusion of exhaust fumes into the vehicle. Non-combustible insulation shall be used.

- 3.3.2** The Exhaust System shall be stainless steel type and conform with all Federal and State requirements applicable to the year of manufacture.

Regulations for Emissions from Vehicles and Engines

REQUEST FOR QUOTATION
ADA Compliant Lowered Floor Minivans

3.4 COOLING SYSTEM

- 3.4.1** Radiator and Cooling System shall be OEM standard, with coolant recovery system utilizing 50-50 mixture of factory specified antifreeze and water.

3.5. FUEL SYSTEM

- 3.5.1** Fuel tank shall be OEM holding between 15 and 25 gallons of gasoline and comply with all accepted industry safety standards.

FMVSS 301

California Air Resource Board (CARB)

3.6 TRANSMISSION

- 3.6.1** Transmission shall be fully automatic with an electronic six to nine speed range.
- 3.6.2** Transmission shift lever shall be interlocked with starting motor to prevent engagement of starter in any gear possible other than neutral or park.
- 3.6.4** A back up camera system will be installed on each vehicle so that the area around the back of the bus is clearly displayed on a monitor that is mounted in an easily visible area for the driver.

3.7 SUSPENSION

- 3.7.1** Suspension system components shall be matched and tuned to provide maximum load capacity, ride quality, stability, and desirable steering and handling characteristics. The vehicle shall be tested to FMVSS 126 Electronic Stability Control Test.

FMVSS 126 Electronic Stability Control Systems

REQUEST FOR QUOTATION
ADA Compliant Lowered Floor Minivans

- 3.7.3 Vendor must perform a front-end alignment after each vehicle is completely built. Vendor shall supply a statement of completion verifying that alignment was completed with warranty information.

3.8 STEERING

- 3.8.1 Power steering is required, and the power steering mechanism shall be constructed so that the vehicle can be easily steered by its operator and shall be such as to make the wheel free from road shock and vibration. The steering mechanism shall be self-centering, requiring little or no effort from the operator to bring the vehicle back to straight ahead position after turning.
- 3.8.2 With the vehicle stationary at GVW on dry, level pavement and the engine idling, steering effort shall be as low as possible at the steering wheel. This effort shall remain approximately constant from just off straight ahead to approaching full lock.
- 3.8.3 The steering geometry shall allow the turning radius maximum characteristics to be achieved in both directions.
- 3.8.5 A tilt-wheel or adjustable steering column, with cruise control is required.

3.9 BRAKES

- 3.9.1 The vehicle shall be equipped with 4-wheel disc brakes and a factory Anti-Lock Brake System, as well as a factory OEM parking brake assemblies and dash warning light.
- 3.9.2 Brakes shall be capable of holding a fully loaded bus on a 20 percent grade.

3.10 WHEELS

- 3.10.1 The vehicle shall be equipped with four OEM wheels appropriate for the vehicle's intended use.

3.11 TIRES

- 3.11.1 The tires shall be OEM standard as specified by the chassis size for intended use.

REQUEST FOR QUOTATION
ADA Compliant Lowered Floor Minivans

3.12 ELECTRICAL SYSTEM

- 3.12.1 Each vehicle shall have an OEM electrical charging system
- 3.12.2 Where penetration of structural members occurs, grommets or similar devices shall be used to prevent chafing.
- 3.12.3 Schematic for all added electrical equipment that shows where added equipment was electrically attached to existing factory electric power.
- 3.12.4 Alternator: Alternator shall be factory installed heavy duty. Must be high output with a minimum of 180 amp.

3.13 INSTRUMENTS AND CONTROLS

- 3.13.1 The following instruments shall be provided:
 - 3.13.1.1 AM/FM digital Bluetooth /radio with clock, MP3, USB
 - 3.13.1.2 Speedometer with recording odometer
 - 3.13.1.3 Ammeter or voltammeter gauge
 - 3.13.1.4 Low-charge warning light
 - 3.13.1.5 Oil pressure gauge
 - 3.13.1.6 Fuel tank level gauge(s)
 - 3.13.1.7 Engine temperature gauge
 - 3.13.1.7 Headlight on indication and headlight high beam indicator
 - 3.13.1.8 Directional signal and flasher action light
 - 3.13.1.9 Parking Brake Indicator
 - 3.13.1.10 Power Port for Cell Phone

REQUEST FOR QUOTATION
ADA Compliant Lowered Floor Minivans

3.14 BODY STRUCTURE

- 3.14.1 Conversion of a minivan by modifying the existing, sidewalls, and floor, shall require the construction that maintains OEM structural equivalent. All metal welded components shall be constructed by qualified operators and made corrosion resistant through a commercial primer application or through the use of stainless steel or aluminum material.
- 3.14.2 Interior Height: Conversion shall provide a minimum clearance of 60" at the vehicle center of the interior roof.
- 3.14.3 Paint: The basic vehicle factory color shall be OEM standard white.
- 3.14.4 All nuts, bolts, clips, washers, clamps, and like-parts shall be galvanized, zinc-coated, or given a coat of primer as additional protection against corrosion. All exterior screws and bolts shall be stainless steel.
- 3.14.5 Interior surfaces of any exterior painted body panels and posts which are covered by trim materials shall be given a coat of primer as additional protections against deteriorations.
- 3.14.6 All exposed surfaces and edges shall be smooth, free from burs and other projections, and shall be neatly finished.
- 3.14.7 The Minivan shall have standard OEM driver and passenger front doors. One manual left side and one manual right OEM side doors extended to floor level, and one OEM rear hatch. The manual left and right-side sliding doors shall be OEM (to the extend the sliding mobility and accessible entry door accommodates the accessible entry ramp) and extended to floor level to provide a minimum entry height of 56". The passenger side sliding mobility aid accessible entry door shall be interlocked to the vehicle transmission and offer a minimum opening height of 56", minimum opening width of 31" (excluding grab handle), and a maximum of 12.5" floor-to-ground height. Both sliding doors shall have a mechanism to securely hold doors in open position when vehicle is on a hill or incline.
- 3.14.8 Passenger Door Tracks: Door tracks shall be reinforced or strengthened beyond OEM standards as appropriate in all areas of contact with sliding door arms.

REQUEST FOR QUOTATION
ADA Compliant Lowered Floor Minivans

- 3.14.9** Sliding Passenger Door Arms/Brackets: Reinforcement of the sliding door components shall at a minimum be adequate to support the increased weight created by the door extensions. Under normal closure conditions, there should be no evidence of door track flexing or wobbling.
- 3.14.10** Door Locks: Power with child-protection door locks for rear doors.
- 3.14.11** Rear Door Emergency Exit: the rear cargo door shall be provided with a quick release, manual override for opening the door from inside the vehicle. Capable of opening the door even if the door is locked. The vehicles override device shall be spring loaded and mounted on the inside of the rear door to prevent accidental release. A decal shall be provided showing operating instructions.
- 3.14.12** Wheel housing shall be steel and should provide clearance for wheels equipped with chains to move freely and to allow a wheel to be removed with the vehicle jacked up as factory recommended – front or back. Rear fenders should be flexible.
- 3.14.13** The entire surface of exterior lowered floor shall have a rust inhibiting coating, such as an epoxy primer base, applied to cover all welded areas, and then a fresh application of undercoating over the entire surface. The warranty shall be 5 years on the undercoat and rustproofing. It is required that the vendor supply the description, warranty and literature information of this product with the bid.
- 3.14.14** The basic interior color shall be OEM gray, with gray (upper) and black (lower) ABS form fitted plastic panels. Panels fastening devices shall match the color of the panels. Interior panels shall meet FMVSS 302. The interior shall provide a pleasant atmosphere, be aesthetically pleasing, and contain smooth finishes without any unprotected sharp edges.
- FMVSS 302
- 3.14.15** A firewall shall separate the engine and passenger compartments, providing both thermal and acoustic insulation, sealing against intrusion of exhaust gases into the vehicle and providing sufficient sound attenuation to maintain a maximum of 86db level in the passenger compartment. The firewall shall be constructed of flame resistant material.

REQUEST FOR QUOTATION
ADA Compliant Lowered Floor Minivans

3.14.16 Roof Gutters

Water deflecting roof gutters shall be provided over ambulatory and Wheelchair accessible doors, over the passenger windows, and over the driver's windshield where necessary.

3.14.17 Exterior

Paint – Surface shall be properly cleaned and primed, as appropriate, for the paint used. All exterior surfaces shall be impervious to gasoline and commercial cleaning agents. The exterior of each van shall be painted a basic white color as furnished by the chassis manufacturer. Fiberglass matching the color of the chassis is acceptable. Finished surfaces shall not be damaged by controlled application of commonly used graffiti- removing chemicals. Touch up paint for each paint color used shall be provided.

3.14.19 Paint Scheme

The vehicle will be delivered without graphics, in a standard white color scheme.

3.15 WINDOWS

3.15.1 Glass shall be OEM laminated, tinted safety glass, with all latch mechanisms recessed

3.15.2 Windshield shall be fixed type, with safety laminated glass, tinted above eye level.

3.16 HEATING AND VENTILATION

3.16.1 An OEM heating/defrosting and air conditioning system with vents front and rear shall be provided. All lines and hoses shall be sufficiently fastened protected, and insulated to ensure against wear from friction and the elements. The lines must be mechanically attached, with OEM or equivalent clamps, to the vehicle structure and must be routed so as not to be exposed to wheel spray. Cold feed lines shall not pass within 2 inches of any part of the exhaust system. Conversion shall not impede access to front and rear air conditioning components.

REQUEST FOR QUOTATION
ADA Compliant Lowered Floor Minivans

3.17 INTERIOR LIGHTING

- 3.17.1** LED lower lighting may be added at the center row location of the vehicle that provides not less than two foot-candles of illumination at the entrance area. This system shall illuminate automatically when the vehicle front or sliding doors are open. All accessory vehicle lighting shall conform to ADA 49 CFR, Part 38, Subpart B.
ADA 49 CFR, Part 38, Subpart B: ADA 49 CFR, Part 38, Subpart B.

3.18 EXTERIOR LIGHTING

- 3.18.1** Exterior lighting shall be in accordance with Federal Motor Carrier Safety Regulations (393.11). All exterior lights to be single contact. Double contact may be used for tail, stop, and rear turn signals.
Federal Motor Carrier Safety Regulation 393.11
- 3.18.2** OEM headlights or LED headlights sealed from moisture intrusion with high and low beams controlled by a column-mounted lever switch or by a foot switch mounted on the floor, which will be sealed from moisture, are required. Headlamps units shall be of the latest type and low beam rating of 600-hour life minimum. Headlights shall be wired for daytime running. Headlights and headlight support and mountings shall be sufficiently rugged to maintain adjustments under road shock and service conditions. Headlight high beam indicator shall be installed on instrument panel. An audible "headlight on" warning buzzer shall be installed to notify the operator that the lights are on with the engine turned off.
- 3.18.3** Tail lamps shall be mounted on the rear of the vehicle so as not to be affected by engine exhaust heat. Each side shall include a hazard, signal, tail, and stop light. Lamp lenses shall not protrude from body more than two inches (2"). Lights shall consist of sealed, single unit light fixtures.
- 3.18.4** Rear tail lamps shall include a pair of amber combinational hazard and signal lights. Rear tail lamps shall also include a pair of red taillights and red stoplights, which may be combinational.

REQUEST FOR QUOTATION
ADA Compliant Lowered Floor Minivans

- 3.18.5 Brake lights shall not override emergency flashers or turn signals. A collision avoidance light shall be installed on the rear at the centerline of the vehicle. It shall be activated simultaneously with the stop lamp circuit.
- 3.18.6 Two (2) back-up lights adequate to illuminate for visibility when backing shall be furnished. One mounted on each side of the vehicle. The lamps shall each be a sealed, single unit light fixture.
- 3.18.7 Passenger entry door area shall adequately illuminate with either an exterior light or interior mounted light to illuminate the area immediately around the passenger side slide door.
- 3.18.8 Each vehicle shall be equipped with an exterior curb lamp. Light shall be positioned in manufacturer's standard location in such a manner as to illuminate the ground area in the immediate vicinity of the area of operation of the wheelchair lift. Light shall be automatically activated only when the wheelchair lift doors are open. Illumination shall be sufficient to comply with ADA requirements.

3.19 INTERIOR DECALS

- 1) "No Smoking" at the front top of vehicle.
- 2) "All Passengers Are Required To Wear Seat Belts When Vehicle Is In Motion" at the front top of the vehicle.
- 3) "Clearance _____ feet _____ inches" above driver's visor. (The specific figures on clearance will be determined by exact dimensions of vehicle.)
- 4) Emergency Dial 911:
- 5) EMERGENCY EQUIPMENT - Apply to the First Aid Kit.

3.20 EXTERIOR DECALS:

- 1) "This Vehicle Makes Frequent Stops" on the back of the vehicle.
- 2) The International Wheelchair Accessibility Symbol on the back of the vehicle.

REQUEST FOR QUOTATION
ADA Compliant Lowered Floor Minivans

- 3) **"CAUTION: Loading and Unloading Passengers"** on the back of vehicle.

The exterior decals shall have 3" lettering shall be white letters on red black ground.

3.21 SEATING

All seats in the vehicle as specified must comply with current FMVSS standards.

FMVSS Standard 207 Seating System

- 3.22.1 **Front Seats:** The driver seat will be OEM and mounted to the vehicle floor.

The OEM front passenger seat shall be equipped to easily lock/unlock from the floor and permit easy roll out for mobility aid access/scurement.

- 3.22.2 **Rear Seat:** The third row 3-passenger bench seat shall be the OEM seat, remounted to be capable of accommodating 3 adult passengers, and is to be covered with OEM upholstery to match the driver and front passenger seats. A manually operated one-piece lighted footrest will be installed for increased comfort of rear bench seat passengers.

- 3.22.3 **Passenger Restraint:** Restraints shall be furnished for all passengers, consisting of shoulder seatbelts and/or lap belts. Each belt shall be equipped with an automatic retractor. Securement devices, both for ambulatory and mobility aid passengers, shall meet all State and Federal Standards.

49 CFR Standard No. 210

- 3.22.4 **Grab Handles:** Grab handle shall be installed, OEM are acceptable.

3.22 ALTOONA BUS TESTING REPORT

The converted minivan must have been submitted to the Altoona Bus Test Center for a 4 year/ 100,000-mile Surface Transportation and Uniform Relocation Assistance Act (STURAA) test. Testing must have been completed on current body style being converted. A copy of the test report should be submitted with the Vendor's submitted bid

REQUEST FOR QUOTATION
ADA Compliant Lowered Floor Minivans

response. This information may be required before award of contract.

FTA Bus Testing Standard

3.23 EMERGENCY/SAFETY EQUIPMENT

3.24.1 First Aid Kit - First-Aid Kit shall comply with Federal Motor Vehicle Carrier Safety Regulations Part 393(h), Section 393, Part 96(c), with a minimum of 15 units. First-aid kits shall be stored in storage compartment or mounted so as to provide for easy access in the event of an accident, away from foot traffic.

Federal Motor Carrier Safety Administration Emergency Equipment

3.24.2 Kit shall be housed in a metal box which contains at least the following items:

- 3.24.2.1** Instant Cold Pack (1)
- 3.24.2.2** Certicaine Burn Spray (1 oz.)
- 3.24.2.3** 1" x 3" Adhesive Bandages (25)
- 3.24.2.4** 3/4" x 3" Adhesive Bandages (10)
- 3.24.2.5** Extra Large Adhesive Bandages (10) 3" x 3"
- 3.24.2.6** Gauze Pads (10)
- 3.24.2.7** Antiseptic Wipes (10)
- 3.24.2.8** Alcohol Prep Pads (20)
- 3.24.2.9** Ammonia Inhalants (10)
- 3.24.2.10** 2" x 6 yds. Gauze Bandage
- 3.24.2.11** 1/2" x 2.5 yds. Adhesive Tape
- 3.24.2.12** Burn Ointment (1/8 oz.) (4)
- 3.24.2.13** Insect Sting Swabs (4)
- 3.24.2.14** PVP Iodine Swabs (4)
- 3.24.2.15** Tweezers (1)

REQUEST FOR QUOTATION
ADA Compliant Lowered Floor Minivans

3.24.2.16 Scissors (1)

3.24.2.17 Safety Pins (5)

3.24.3 Fire Extinguisher - A 5 lb. dry chemical fire extinguisher with a minimum of a 20-A: 180-B:C rating shall be provided in vehicle and shall be mounted in an access compartment with a hinged door or on a vehicular-type quick access bracket away from foot traffic.

3.24.4 Reflectors - Three bi-directional emergency reflective triangles conforming to requirements of FMVSS No. 125, Section 571.125 shall be secured in the storage compartment of the vehicle.

FMVSS No. 125, Section 571.125

3.24.5 Jumper Cables - Jumper cables of stranded copper, 4-6 gauge, seven (7) feet minimum length shall be secured in the storage compartment of the vehicle.

3.24.6 Bloodborne Pathogen Protection Kit - A 10-unit (minimum) kit housed in a polypropylene or metal box and containing at least the following items:

3.24.6.1 Gown/Cap (1)

3.24.6.2 Goggles (Eye Shield) (1)

3.26.6.3 Mask (1)

3.26.6.4 Sets of Gloves (3)

3.26.6.5 Scraper (1)

3.26.6.6 Crepe Towels (2)

3.26.6.7 Antiseptic Towelettes (4)

3.26.6.8 Disinfectant Towelette (4)

3.26.6.9 Mouth to Mouth Barrier (1)

3.26.6.10 Scoop Bag (3)

3.26.6.11 Infectious Liquid Control Powder (2 oz.)

3.26.6.12 Red Bio-Hazard Bags with Ties (2)

REQUEST FOR QUOTATION
ADA Compliant Lowered Floor Minivans

3.24.7 Wheel Jack & Lug Wrench secured in a location approved by the Division of Public Transit.

3.24.8 Seat Belt Cutter – shall be secured in the storage compartment of the vehicle.

3.24 MIRRORS

3.25.1 Interior OEM Rearview Mirror.

3.25.2 Exterior Two rearview, one right and one left power adjustable mirrors to be installed. If not OEM, it is required that the vendor supply the description, warranty and literature information of this product with the bid.

3.25 FRONT AND REAR HEATING AND AIR CONDITINING

3.26.1 An OEM heating/defrosting and air condition system with vents front and rear shall be provided. All lines and hoses shall be sufficiently fastened, protected, and insulated to ensure against wear from friction and the elements. The lines must be mechanically attached with OEM clamps, to the vehicle structure at no greater than 18-inch intervals and must be routed so as not to be exposed to wheel spray and not pass within 2 inches of any part of the exhaust system. Conversion shall not impede access to front and rear air condition components.

3.26 WHEELCHAIR SECUREMENT SYSTEM

3.27.1 It is required that the vendor supply the description, warranty and literature information of this product with the bid.

3.27.2 Wheelchair securement areas and systems shall fully comply with all applicable U.S. Department of Transportation's Americans with Disabilities Requirements. NHTSA requires a 3-point shoulder restraint system shall be supplied for each passenger for vehicles under 10,000 GVWR.

3.27.3 Vehicle shall be equipped with one (1) wheelchair position. Each required wheelchair position a wheelchair securement system shall be provided to securely hold the wheelchair in the wheelchair position.

3.27.4 Provisions shall be made, in the wheelchair position area, to stow the straps and buckles off the floor when they are not in use. The stored straps shall not interfere with passenger movement or sitting space. Vendor shall

REQUEST FOR QUOTATION
ADA Compliant Lowered Floor Minivans

submit description and location of product with bid.

3.27.5 The vendor shall provide with each vehicle upon delivery a pamphlet, brochure or similar literature describing and instructing the use of the wheelchair securement system and shall demonstrate to the recipient the proper method of using the system. Demonstration of the securement system must be performed to insure correct use of the system.

3.27.6 A Freedman Seating 3 Step Forward Facing Fold Down Double Seat, or equal, shall be used in every wheelchair position for use by non-disabled persons when the securement system is not needed. When folded up, the seat shall not interfere with the use of the wheelchair positions by passengers in wheelchairs. An under-seat retractable seat belt shall be provided for each seated position.

3.27.7 The wheelchair station shall have a securement system fully complying with ADA requirements and capable of securing most common wheelchairs and other mobility aid devices. Each wheelchair space shall have at least 3-5" in between each space for easy access of driver.

3.28 WHEELCHAIR OCCUPANT RESTRAINT SYSTEM

3.28.1 A restraint system shall be provided for the occupant of the wheelchair at each wheelchair position. The restraint system shall be a seat belt assembly permanently attached to the floor or side of the vehicle or to the wheelchair lock supports. The restraint system shall be capable of securing a passenger in all types of wheelchairs or Scooters, while the chairs are locked in position. The seat belt shall be at least eighty (80) inches long and shall be easily fastened and unfastened by the wheelchair occupant. Each seat belt shall be equipped with a retractor or other device, which keeps the seat belt webbing or strap off the floor when the seat belt is not in use.

3.28.2 A complete retractable wheelchair and occupant restraint system with S-Hooks shall be installed at the wheelchair location. The system will have automatic belt retractors; tensioning knobs; and easy to use tension release mechanisms. The system shall be a Titan AL712S-4C; Q-Straint QRT Deluxe or approved equal. L-Track System to be used.

3.28.2.1 Wheelchair retractors shall be fully automatic, auto locking and self-tensioning.

REQUEST FOR QUOTATION
ADA Compliant Lowered Floor Minivans

- 3.28.2.2 Retractors shall automatically remove any slack in the webbing after they are secured to the wheelchair.
- 3.28.2.3 Retractors are self-retracting; therefore, no belts are left on the floor, keeping them cleaner and longer lasting.
- 3.28.2.4 Retractor shall have a "LOCKED" indicator tag and shall only be visible when the retractor is in the LOCKED mode assuring the retractor is not in the release condition when properly secured to the wheelchair.
- 3.28.2.5 Retractors shall be heavy duty with heat treated structural components and plated for superior corrosion resistance.
- 3.28.2.6 Retractors shall have appropriately finished metal cover for long lasting protection.
- 3.28.2.7 Retractors shall have colored webbing and the occupant restraints shall be of a contrasting color for easy identification in the field.
- 3.28.2.8 Retractors shall be designed to be low profile to fit under most wheelchair footrests.
- 3.28.2.9 Retractors shall be equipped with anchoring points for the attachment of the occupant restraint lap belts.
- 3.28.2.10 Retractors shall be able to be used with a variety of shoulder/lap Belt combinations.
- 3.28.2.11 Retractors shall have manual knobs for additional tightening if needed.
- 3.28.2.12 Retractor shall be able to secure a wheelchair with one hand in as little as 10 seconds.
- 3.28.2.13 Retractors shall have a warranty period of at least the industry standard and shall have a manufacturing label to identify the part number and date of manufacture for easy traceability.
- 3.28.2.14 Retractors, occupant restraints and anchoring equipment shall be installed in accordance with the manufacturer's installation instructions and recommendations.
- 3.28.2.15 Retractors and occupant restraints shall meet or exceed but not limited to the following specifications:

REQUEST FOR QUOTATION
ADA Compliant Lowered Floor Minivans

SAE J2249

ISO 10542

National Standard for School Buses Standard 222

ADA 49 CFR Part 38

FMVSS 209

FMVSS 302

Canadian Z605

It is required that the vendor supply the description, warranty and literature information of this product with the bid.

3.29 WHEELCHAIR RAMP:

3.29.1 The vehicle shall be equipped with a manually operated access ramp which stows vertically or under the floor and is deployed through the right-side sliding door. The fold and unfold motion of the ramp must be counter balanced so that the operator can easily deploy the ramp. The installed ramp shall not obstruct the view of the driver through any vehicle window. The ramp shall have a minimum usable width of 30" and a slope meeting the requirements of ADA, 49 CFR. The ramp surface shall be continuous and made skid resistant. It shall accommodate both four-wheel and three-wheel mobility aids. The ramp shall have a rated capacity of 1000 lbs. and possess industry standard protective features.

ADA CFR 49

3.30 AM/FM DIGITAL BLUETOOTH/ RADIO WITH CLOCK

Vehicle shall be equipped with the OEM's AM/FM radio/USB/MP3 stereo with with Bluetooth connectivity.

3.31 MISCELLANEOUS ADDITIONS

3.31.1 Each vehicle shall be equipped with rear window defroster.

3.31.2 Each vehicle shall have installed power windows and locks on all doors.

3.31.3 Each vehicle shall be equipped with driver and passenger air bags.

REQUEST FOR QUOTATION
ADA Compliant Lowered Floor Minivans

3.31.4 Each vehicle shall be equipped with a sun visor for driver and front passenger that is able to pivot to cover their doors.

3.31.5 Provide and install in each vehicle Angel Trax Vulcan Series V12 HD IP Mobile DVR Security Camera System with 6 cameras or equivalent having One TB SATA Hard drive with back up recording on SD Card and six audio/video channels or equivalent.

3.32 MANUALS

The vendor shall furnish each vehicle with complete driver, parts and maintenance manuals, including AS-BUILT wiring schematics of auxiliary circuits, air line diagrams and all other necessary prints for the maintenance of the wheelchair lift, auxiliary air conditioning unit and any other optional items added by the vendor during conversion.

3.33 UNSPECIFIED ACCESSORIES & FEATURES

All parts, equipment, accessories, material, design and performance characteristics not specified herein, but which are necessary to provide a complete unit, must be furnished with each unit and required to confirm to strength, quality of material, and quality of workmanship to those which are advertised and provided to the market in general by the unit industry. All parts and accessories advertised and regularly supplied as standard shall be included, except those which would represent duplication of these specified and except those which, by specification, are not to be furnished. All standard safety features, required by Federal and State Law, shall be included. Vehicles must have all equipment found on the manufacturer's base model plus other equipment requirements, packages, items, etc. needed to meet the specifications.

4 REQUIREMENTS SPECIFIC TO EACH VEHICLE CLASS

4.1 Class A: Vehicles identified as Class A vehicles must meet the following mandatory requirements in addition to the requirements listed in Section 3. Class A Vehicle will NOT have any Striping or Logo's, Painted White.

4.1.1 Measurements and Other Specifications:

GVWR	6,000 minimum
WHEELBASE	121" Minimum
SEAT/WHEELCHAIR CAPACITY	Five / One
PASSENGER HEAT & A/C	OEM Front & Rear System
ENGINE TYPE	Gasoline
ENGINE CAPACITY	Displacement of at least 3.0 liters and no more than 4.0 liters providing between 280 – 300

Commented [DP1]: 4.1 Same as above for Engine Capacity

REQUEST FOR QUOTATION
ADA Compliant Lowered Floor Minivans

	horsepower with the operating fuel expenditure being between 15-21 City and 24-30 Highway miles
BRAKES	4 Wheel Disc / Anti-Lock System
BATTERY	OEM
WHEELCHAIR RAMP	Manual / Right Side

5 ADDITIONAL REQUIREMENTS APPLICABLE TO ALL VEHICLES

5.1 Summary of Items To Be Provided Upon Delivery

The following items shall be furnished by the successful Vendor upon delivery of the vehicle:

- a. All warranty verification vouchers, certificates or coupons.
 - b. Supply two (2) sets of the following manuals, per model year, for each transit authority that receives vehicles:
 - Two (2) complete parts books
 - Two (2) maintenance manuals
 - Including wiring schematics of auxiliary circuits and all other necessary prints for the maintenance of the vehicle and
 - One (1) OEM operations manual
- For other agencies receiving vehicles, the successful bidder shall supply one (1) copy of each mentioned per vehicle.
- c. Completely filled fuel tank or tanks.
 - d. Protection to 20° F below zero with permanent type antifreeze.
 - e. A vehicle(s) free of dealer signs and emblems.
 - f. Assurance of compliance with manufacturer's pre-delivery service.
 - g. A vehicle(s) which is clean, (If delivery of the vehicle occurs during the winter months of October through March, the vehicle shall be washed directly prior to delivery at designated recipient or Kanawha Valley Regional Transportation Authority to ensure that the vehicle is free of dirt and salt deposits) lubricated, serviced and ready for immediate service.
 - h. Operation, maintenance and warranty information for any add on equipment will be provided upon delivery if available to the Vendor.

REQUEST FOR QUOTATION
ADA Compliant Lowered Floor Minivans

- i. Original vehicle chassis manufacturer's factory sticker itemizing equipment on the vehicle.
- j. A certified weight slip showing front and drive axle weights for the vehicle at its curb weight as defined in Technical Specifications.
- k. Proof of Alignment.
- l. Vehicle shall comply with and conform to the State of West Virginia Motor Vehicle Inspection Law and shall have the current inspection sticker attached to the windshield.

5.2 Title

Adequate documents for securing the vehicle in the name of the Division shall be provided to the Division at least 10 working days prior to the delivery of each vehicle. The Vendor warrants that the title shall pass to the Division free and clear of all liens, mortgages and encumbrances, financing statements, security agreements, claims and demands of any character.

According to WV State Code §5A-3-4(8), vendor agrees that liquidated damages shall be imposed at the rate of \$10 per calendar day for failure to provide the titling documentation at the time of vehicle delivery. This clause shall in no way be considered exclusive and shall not limit the State or agency's right to pursue any other additional remedy to which the State or agency may have legal cause for action including further damages against the vendor.

All documentation (Certificate of Origin, Delivery/Odometer Statement, Etc.) in original form must be mailed or hand carried to:

WV Division of Multimodal Transportation Facilities -
Public Transit
1900 Kanawha Blvd., East
Building 5, Room 663
Charleston, WV 25305

REQUEST FOR QUOTATION
ADA Compliant Lowered Floor Minivans

5.3 QUALITY ASSURANCE

5.3.1 QUALITY ASSURANCE ORGANIZATION

The Vendor shall establish and maintain an effective quality assurance organization. It shall be a specifically defined organization and should respond directly to the Vendor's management. The Vendor's complete quality assurance program for purchased components and in-plant inspection procedures shall be available for review by the Division prior to award.

Control

The quality assurance organization shall exercise quality control over all phases of production from initiation of design through manufacture and preparation for delivery. The organization shall also control the quality of supplied articles.

Authority and Responsibility

The quality assurance organization shall have the authority and responsibility for reliability, quality control, inspection planning, establishment of the quality control system, and acceptance/rejection of materials and manufactured articles in the production of the vehicles.

5.3.2 QUALITY ASSURANCE ORGANIZATION FUNCTIONS

The quality assurance organization shall include the following minimum functions.

Work Instructions

The quality assurance organization shall verify inspection operation instructions to ascertain that the manufactured product meets all prescribed requirements.

Records Maintenance

The quality assurance organization shall maintain and use records and data essential to the effective operation of its program. These records and data shall be available for review by the resident inspectors. Inspection and test records for this procurement shall be available for a minimum of one (1) year after inspections and test are completed.

Corrective Actions

The quality assurance organization shall detect and promptly assure correction of Any condition that may result in the production of defective vehicles. These conditions may occur in designs, purchases, manufacture, tests, or operations that

REQUEST FOR QUOTATION
ADA Compliant Lowered Floor Minivans

culminate in defective supplies, facilities, technical data, or standards.

5.3.3 STANDARDS AND FACILITIES

Configuration Control

The Vendor shall maintain drawings and other documentation that completely describe a quality vehicle that meets all of the options and special requirements of this procurement. The quality assurance organization shall verify that each vehicle is manufactured in accordance with these controlled drawings and documentation.

Measuring and Testing Facilities

The Vendor shall provide and maintain the necessary gauges and other measuring and testing devices for use by the quality assurance organization to verify that the vehicles conform to all specification requirements. These devices shall be calibrated at established periods against certified measurement standards that have known valid relationships to national standards.

Production Tooling as Media of Inspection

When production jigs, fixtures, tooling master patterns, and other devices are used as media of inspection, they shall be proved for accuracy at formally established intervals and adjusted, replaced, or repaired as required to maintain quality.

Equipment Use By Division's Inspector(s)

The Vendor's gauges and other measuring and testing devices shall be made available for use by the Division's inspector(s) to verify that the vehicles conform to all specification requirements. If necessary, the Vendor's personnel shall be made available to operate the devices and to verify their condition and accuracy.

5.3.4 CONTROL OF PURCHASES

The Vendor shall maintain quality control of purchases.

Supplier Control

The Vendor shall require that each supplier maintains a quality control program for the services and supplies that it provides. The Vendor's quality assurance organization shall inspect and test materials provided by suppliers for conformance to specification requirements. Materials that have been inspected, tested, and approved shall be identified as acceptable to the point of use in the manufacturing or assembly processes. Controls shall be established to prevent inadvertent use of non-conforming materials.

REQUEST FOR QUOTATION
ADA Compliant Lowered Floor Minivans

Purchasing Data

The Vendor shall verify that all applicable specification requirements are properly included or referenced in purchases of articles to be used on vehicles.

5.3.5 MANUFACTURING CONTROL

The Vendor shall ensure that all basic production operations, as well as all other processing and fabricating, are performed under controlled conditions, establishment of these controlled conditions shall be based on the documented work instructions, adequate production equipment, and special working environments if necessary.

Completed Items

A system for final inspection and test of completed vehicles shall be provided by the quality assurance organization. It shall measure the overall quality of each completed vehicle.

Non-conforming Materials

The quality assurance organization shall monitor the Vendor's system for controlling non-conforming materials. The system shall include procedures for identification, segregation, and disposition.

Statistical Techniques

Statistical analysis, tests, and other quality control procedures may be used when appropriate in the quality assurance processes.

Inspection Status

A system shall be maintained by the quality assurance organization for identifying the inspection status of components and completed vehicles. Identification may include cards, tags, or other normal quality control devices.

5.3.6 INSPECTION SYSTEM

The quality assurance organization shall establish, maintain, and periodically audit a fully documented inspection system. The system shall prescribe inspection and test of materials, work in progress and completed articles. At a minimum, it shall include the following controls.

REQUEST FOR QUOTATION
ADA Compliant Lowered Floor Minivans

Inspection Stations

Inspection stations shall be at the best locations to provide for the work content and characteristics to be inspected. Stations shall provide the facilities and equipment to inspect structural integrity; electrical; hydraulic; through floor securements; OEM defects; coverage of the undercoating; and other components and assemblies for compliance with the design requirements.

Stations shall also be at the best locations to inspect or test characteristics before they are concealed by subsequent fabrication or assembly operations. These locations shall minimally include, as practicable, underbody structure completion, body framing completion, body prior to paint preparation, water test before interior trim and insulation installation, engine installation completion, underbody dress-up and completion, vehicle prior to final paint touch up, vehicle prior to road test, and vehicle final road test completion.

The manufacturer shall provide on its premises a suitable means for a complete inspection of the underside of the vehicle.

Inspection Personnel

Sufficiently trained inspectors shall be used to ensure that all materials, components, and assemblies are inspected for conformance with the qualified vehicle design.

Inspection Records

Acceptance, rework, or rejection identification shall be attached to inspected articles. Articles that have been accepted as a result of approved materials review actions shall be identified. Articles that have been reworked to specified drawing configurations shall not require special identification. Articles rejected as unsuitable or scrap shall be plainly marked and controlled to prevent installation on the vehicle. Articles that become obsolete as a result of engineering changes for other actions shall be controlled to prevent unauthorized assembly or installation. Unusable articles shall be isolated and then scrapped.

Discrepancies noted by the Vendor or Division's inspector during assembly shall be entered by the inspection personnel on a record that accompanies the major component, subassembly, or vehicle from start of assembly through final inspection. Actions shall be taken to correct discrepancies or deficiencies in the manufacturing processes, procedures, or other conditions that cause articles to be in nonconformity with the requirements of the contract specifications. The inspection personnel shall verify the corrective actions and mark the discrepancy record. If discrepancies cannot be corrected by replacing the non-conforming materials, the

REQUEST FOR QUOTATION
ADA Compliant Lowered Floor Minivans

Division shall approve the modification, repair, or method of correction to the extent that the contract specifications are affected.

Quality Assurance Audits

The quality assurance organization shall establish and maintain a quality control audit program. Records of this program shall be subject to review by the Division.

Division's Inspector(s)

The Division may be represented at the Vendor's plant by their inspectors, they shall monitor, in the Vendor's plant, the manufacture of vehicles built under this procurement. The Division's inspectors shall be authorized to release the vehicles for delivery. Upon request to the quality assurance supervisor, inspectors shall have access to the Vendor's quality assurance files related to this procurement. These files shall include drawings, material standards, parts lists, inspection processing and reports, and records of defects. The presence of these inspectors in the plant shall not relieve the Vendor of its responsibility to meet all of the requirements of this procurement.

The Division's inspectors shall not have the authority to stop the Vendor's production line until any apparent problem area of major significance that arises to warrant such actions is fully discussed with the Vendor's top management.

5.4 SERVICE AND PARTS

The Vendor shall state on Bid Form #1 the representative(s) responsible for assisting the Recipient Agencies, as well as, the location of the nearest distribution center(s) which shall furnish a complete supply of parts and components for the repairs and maintenance of the vehicles to be supplied.

5.5 Materials and Workmanship

- a. Vendor shall incorporate in the proposed vehicle(s) the latest technological achievements consistent to achieving maximum service life and superior attractiveness of appearance.
- b. Vehicle(s) shall be delivered in new, first-class condition, complete and ready for operation on the street and the Vendor shall assume all responsibility and liability incident to said delivery.
- c. All materials used in the construction of vehicle(s) and in all its parts and accessories shall conform to A.S.T.M., S.A.E., or similar associations published standards, and be of top quality.

REQUEST FOR QUOTATION
ADA Compliant Lowered Floor Minivans

- d. The vehicle(s) shall be built with suitable and easily accessible compartments provided for all apparatus, sound deadening insulation, wherever needed, and all operating devices so mounted as to reduce and keep all noise and vibration to an absolute minimum.
 - e. Vendor shall assume responsibility for all material and accessories used in vehicle(s) and their proper installation and their warranty, whether the same is manufactured by the Vendor or purchased ready-made from a source outside the Vendor's company.
- 5.6 Spare Parts** – The Vendor shall guarantee the availability of replacement parts for these vehicles for at least a seven (7) year period after the date of acceptance. Spare parts shall be interchangeable with the original equipment and shall be manufactured in accordance with the quality assurance provision of this contract.
- 5.7 Engineers** – The Vendor shall, at its own expense, have a competent engineering representative(s) available on request to assist the Recipient Agencies staff in the solution of engineering or design problems within the scope of the specifications that may arise during the warranty period.
- 5.8 Documents** –The Vendor shall keep maintenance manuals available for a period of ten (10) years after the date of acceptance of the vehicles procured under this contract. The Vendor shall also keep parts books up to date for a period of ten (10) years. The supplied maintenance and operators' manuals shall incorporate all equipment ordered on the vehicles covered by this procurement.

5.9 WARRANTIES

The Vendor has an obligation to ensure that the entire vehicle is covered by a warranty. The Vendor shall make every effort to assure that all obligations defined under all warranties applicable to the vehicle or any subpart of the vehicle are unfilled.

5.9.1 WARRANTY REQUIREMENTS

Warranties in this document are in addition to any statutory remedies or warranties imposed on the Vendor. Consistent with this requirement the Vendor warrants and guarantees to the Division each complete vehicle, and specific subsystems and components as follows:

5.9.2 Complete Vehicle

The vehicle is warranted and guaranteed to be free from defects and related defects for three (3) years or 36,000 miles, whichever comes first, beginning on the first day after the date of final acceptance of each vehicle. During this warranty period, the vehicle shall maintain its structural and functional integrity. The warranty is based on regular operation of the vehicle under the operating conditions prevailing in the Recipient Agencies locales.

REQUEST FOR QUOTATION
ADA Compliant Lowered Floor Minivans

5.9.2 Warranty of Basic Vehicle Structure

The Vendor shall warranty the frame and suspension members for three (3) years or 36,000 miles, whichever comes first. This warranty shall not cover air bags, leveling valves, springs or other normal wearing parts. The Vendor is not liable for warranty if the Recipient Agencies voids the warranty as outlined in this Section. If the frame or suspension fails or shows indication of imminent failure, the Recipient Agencies will immediately notify the Vendor of said defect. Within ten (10) calendar days the Vendor will inform the Recipient Agencies on how the Vendor will repair the vehicle. Repair of frame and suspension failures will be the responsibility of the Vendor. Within fifteen (15) calendar days from notification of the defect the Vendor shall begin the repair of the frame and suspension defects. If the vehicle with the reported frame and suspension defect is out of revenue service for more than twenty (20) calendar days because of the reported defect, the Vendor will have to either provide a substitute vehicle of equal seating capacity with wheelchair lift (if applicable) of the same age or newer than the vehicle with the defect or directly reimburse the Recipient Agencies the cost of leasing a substitute vehicle. The maximum daily reimbursement will be \$300. The Vendor will have to continue to provide a substitute vehicle or reimburse the Recipient Agencies until the defect is completely repaired.

5.9.3 Warranty Locations

A description of how and by whom warranty service is to be provided in four (4) areas of West Virginia is to be included in the bid proposal. The information should cover both mechanical and body work. All bidders shall provide vendors who will do the warranty of both chassis and body, including vehicle body, air conditioning and wheelchair lifts. The four warranty service areas of West Virginia include: The Northern Panhandle, Eastern Panhandle, Central West Virginia and Southern West Virginia.

5.9.4 Subsystems and Components

The subsystems and components are warranted and guaranteed to be free from defects and related defects as follows:

ENGINE: Three (3) years or 36,000 miles, whichever comes first.

TRANSMISSION: Three (3) years or 36,000 miles, whichever comes first.

DRIVE AXLE: Three (3) years or 36,000 miles, whichever comes first.

BRAKE SYSTEM: Excluding friction material,
Three (3) years or 36,000 miles
whichever comes first

REQUEST FOR QUOTATION
ADA Compliant Lowered Floor Minivans

BASIC BODY Three (3) years or 36,000
STRUCTURE miles, whichever comes first.
INTEGRITY:

AIR CONDITIONING Three (3) years or 36,000 miles
SYSTEM:

WHEELCHAIR Two (2) years
RAMP SYSTEM:

ALL ADD ON COMPONENTS: Two (2) years, unlimited miles

5.9.5 VOIDING OF WARRANTY

The warranty shall not apply to any part or component of the vehicle that has been subject to misuse, negligence, accident, or that has been repaired or altered in any way so as to affect adversely its performance or reliability, except insofar as such repairs were in accordance with the Vendor's maintenance manuals and the workmanship was in accordance with recognized standards of the industry. The warranty shall also be void if the Recipient Agencies fails to conduct normal inspections and scheduled preventative maintenance procedures as recommended in the Vendor's maintenance manuals.

5.9.6 EXCEPTIONS TO WARRANTY

The warranty shall not apply to scheduled maintenance items, and items such as tires and tubes, nor to items furnished by the Recipient Agencies such as radios, fare boxes and other auxiliary equipment, except insofar as such equipment may be damaged by the failure of a part or component for which the Vendor is responsible.

5.9.7 DETECTION OF DEFECTS

If the Recipient Agency detects a defect within the warranty periods defined in Section 5.10.1 of this Part, it shall promptly notify the Vendor's representative five (5) working days after receipt of notification, the Vendor's representative shall either agree that the defect is in fact covered by warranty, or reserve judgment until the subsystem or component is inspected by the Vendor's representative or is removed and examined at the Recipient Agencies property or at the Vendor's plant. At that time, the status of warranty coverage on the subsystem or component shall be mutually resolved between the Recipient Agency and the Vendor. Work necessary to affect the repairs defined in Section 5.10 of this Part shall commence within ten (10) working days after receipt of notification by the Vendor.

REQUEST FOR QUOTATION
ADA Compliant Lowered Floor Minivans

5.9.8 SCOPE OF WARRANTY REPAIRS

When warranty repairs are required, the Recipient Agencies and the Vendor's representative shall agree within five (5) days after notification on the most appropriate course for the repairs and the exact scope of the repairs to be performed under the warranty. If no agreement is obtained within the five (5) day period, the Recipient Agencies reserves the right to commence the repairs in accordance with Section 5.10.

5.9.9 FLEET DEFECTS

A fleet defect shall be defined as the failure of any identical items covered by the warranty and the specifications herein, and occurring in a twenty percent (20%) portion of the vehicles purchased under this contract.

The Vendor shall correct a fleet defect under the warranty provision. After correcting defect, the Vendor shall promptly undertake and complete a work program reasonably designed to prevent the occurrence of the same defect in all other vehicles purchased under this contract. The work program shall include inspection and/or correction of the potential or defective parts in all of the vehicles purchased under this contract. The warranty on items determined to be fleet defects shall be extended for the time and/or miles of the original warranty. This extended warranty shall begin on the date of the repair/replacement for the corrected item.

5.10 REPAIR PROCEDURES

5.10.1 Repair Performance

At its option, the Division, or its designated representative, may require the Vendor, or its designated representative, to perform warranty covered repairs that are clearly beyond the scope of Recipient Agencies capabilities. All warranty work done by Recipient Agencies personnel will be reimbursed by the Vendor.

5.10.2 Repairs by Vendor

If the Recipient Agencies requires the Vendor to perform warranty covered repairs, the Vendor's representative must begin the work necessary to make repairs, within ten (10) working days after receiving notification of a defect from the Recipient Agencies. The Recipient Agencies shall make the vehicle available to complete repairs timely with the Vendor's repair schedule.

The Vendor will provide, at its own expense, all spare parts, tools and space required to complete repairs. At the Recipient Agencies option, the Vendor may be required to complete repairs. At the Recipient Agencies option, the Vendor may be

REQUEST FOR QUOTATION
ADA Compliant Lowered Floor Minivans

required to remove the vehicle from Recipient Agency's property while repairs are being effected. If the vehicle is removed from Recipient Agency's property, repair procedures must be diligently pursued by the Vendor's representative.

5.10.3 Repairs by Recipient Agencies

a. **Parts Used**

If the Recipient Agency performs the warranty covered repairs, it shall correct or repair the defect and any related defects using Vendor specified spare parts available from its own stock or those supplied by the Vendor specifically for this repair. Monthly, or at a period to be mutually agreed upon, reports of all repairs covered by this warranty shall be submitted by the Recipient Agency to the Vendor for reimbursement or replacement of parts. The Vendor shall provide forms for these reports.

b. **Vendor Supplied Parts**

The Recipient Agency may request that the Vendor supply new parts for warranty covered repairs being performed by the Recipient Agency. These parts shall be shipped prepaid to the Recipient Agency from any source selected by the Vendor within 10 (ten) working days of receipt of the request for said parts.

c. **Defective Components Return**

The Vendor may request that parts covered by the warranty be returned to the manufacturing plant. The total cost for this action shall be paid by the Vendor. Materials should be returned in accordance with Vendor's instructions.

d. **Reimbursement for Labor**

The Recipient Agencies shall be reimbursed by the Vendor for labor. The amount shall be determined by multiplying the number of man-hours actually required to correct the defect by the current per hour, straight wage rate, plus 53 percent fringe benefits, plus the cost of towing in the vehicle if such action was necessary and if the vehicle was in the normal service area.

These wage and fringe benefit rates shall not exceed the rates in effect in the Recipient Agencies service garage at the time the defect correction is made.

REQUEST FOR QUOTATION
ADA Compliant Lowered Floor Minivans

e. **Reimbursement for Parts**

The Recipient Agencies shall be reimbursed by the Vendor for defective parts and for parts that must be replaced to correct the defect. The reimbursement shall be at the invoice cost of the part(s) at the time of repair and shall include taxes where applicable and 10 percent handling costs.

5.10.4 WARRANTY AFTER REPLACEMENT/REPAIRS

If any component, unit, or subsystem is rebuilt or replaced by the Vendor or by the Recipient Agencies personnel, with the concurrence of the Vendor, the subsystem shall have the unexpired warranty period of the original subsystem.

6 CONTRACT AWARD

6.1 Contract Award: The Contract is intended to provide Agencies with a purchase price on all Contract Items. The Contract shall be awarded to the Vendor that provides the Contract Items meeting the required specifications for the lowest overall total cost as shown on the Pricing Pages.

6.2 The Federal Transit Administration's "Third Party Contracting Circular" (4220.1F), requires grantees (the DPT) to conduct procurements in a manner that prohibits the use of statutorily or administratively imposed In-State or local geographical preferences in the evaluation of bids or proposals, except in those cases where applicable Federal statutes expressly mandate or encourage geographic preference.

Therefore, the In-State vendor preference per West Virginia Code 5A-3-37 shall not apply to this procurement since it is partially or entirely funded with Federal Transit Administration funds.

7. PRICING PAGE

7.1 Pricing Pages: Vendor should complete Exhibit A Pricing Page by listing the unit price for each vehicle class, multiplying the unit price by the estimated quantity to arrive at an extended price, and then adding the extended prices for each Class to arrive at a total. All prices quoted are to be in whole dollars and include delivery charges.

7.2 Exhibit A Pricing Page contains a list of the Contract Items and estimated purchase volume. The estimated purchase volume for each item represents the approximate volume of anticipated purchases only. No future use of the Contract or any individual item is guaranteed or implied.

7.3 Vendor should electronically enter the information into the Pricing Pages through wvOASIS, if available, or as an electronic document.

REQUEST FOR QUOTATION
ADA Compliant Lowered Floor Minivans

- 7.4 Additional agencies, as noted, could purchase from any awarded contract resulting from this bid. Specified deliverables would be as originally advertised, competed, evaluated and awarded.

8. VENDOR QUALIFICATIONS

The Vendor must be a person, firm or corporation that:

- a. Has in operation, a manufacturing plant adequate to assure delivery of all equipment within the time specified under the contract.
- b. Has adequate engineering and service personnel, or has the capability to have such personnel, to satisfy any engineering or service problems that may arise during the warranty period.
- c. Has similar vehicles in operation in comparable service for a minimum of one (1) year. The Vendor may be required to furnish a customer list indicating the number of units and dates in service during or equal period of during the bid evaluation period in addition to the requirements under Section 10.2 of these specifications.
- d. In lieu of this requirement, certified results of a shaker test may be requested by the Division during the or equal period to prove the proposed vehicles to be capable of operating the service contemplated for these vehicles.
- e. Has the necessary facilities and financial resources to complete the contract in a satisfactory manner within a required time. The Division shall have the right to conduct a pre-award survey of each Vendor.
- f. Has completed and accurate maintenance, parts, and operators' manuals.

9. MISCELLANEOUS ITEMS TO BE SUPPLIED WITH BID

- 9.1 Federal Transit Administration (FTA) Terms and Conditions and Certifications: Current FTA Terms and Conditions are included in this bid and must be met. Certifications for Vehicle Purchases, including Vehicle Pollution Requirements, Federal Motor Vehicle Safety Standards, Debarred Bidders, Disadvantaged Business Enterprise Manufacturers, Buy America Rolling Stock, Restrictions on Lobbying are provided on Bid Form Pages #1 - #10. All bid forms provided shall be properly completed and furnished by the Vendor as part of the bid. Failure to submit any of these forms shall disqualify the bid.
- 9.2 Pre-Award Review – The Vendor shall submit the following items and any further items if requested.

REQUEST FOR QUOTATION
ADA Compliant Lowered Floor Minivans

- A. Complete mechanical description of vehicle, its construction and equipment including manufacturer's model name and/or number. Equipment to be described shall include the wheelchair lift, air conditioner, flip-up seat, and wheelchair securement system, if these items are specified herein.
- B. Proposed interior floor plans, showing detailed dimensions including the location of the wheelchair securement system and stanchions if specified.
- C. Curb weight (empty weight) and gross vehicle weight rating (GVWR) of vehicle.
- D. Samples or paint charts of available exterior paint colors and vinyl.
- E. Description of the warranties the Vendor proposes to furnish for the vehicle and for required ancillary equipment, including a listing of sites where warranty work will be performed.
- F. The location of the nearest depot which will furnish a complete supply of parts and components for the repair and maintenance of the vehicle to be supplied.
- G. Description of the undercoating/rustproofing system, including warranty to be provided.
- H. Identification of the specific location of the place of assembly in the case of a bus or the place of a conversion in the case of a converted van. If the location changes, the Vendor must notify the Division, in which case the Division reserves the right to perform an inspection similar to the pre-award inspection identified. If the results of the inspection are unsatisfactory, the Division may begin the contract termination process through the WV State Purchasing Division.

9.3 Disadvantaged Business Enterprise (DBE)

- A. All U.S. Department of Transportation, Federal Transit Administration (FTA) assisted contracts between FTA, the Division, and any Vendor shall include the following language:
 - 1) **Policy** – It is the policy of the U.S. Department of Transportation that Disadvantaged Business Enterprises (DBE) as defined in 49 CFR Part 26 that DBEs shall have the maximum opportunity to participate in the performance of contracts financed in whole or in part with federal funds under this agreement. Consequently, the DBE requirements of 49 CFR Part 26 apply to the agreement.
 - 2) **DBE Obligation** – The recipient or its Vendor agrees to ensure that DBEs as defined in 49 CFR Part 26 shall have the maximum opportunity to participate in the performance of contracts financed in whole or in part with federal funds under this agreement. Consequently, the DBE

REQUEST FOR QUOTATION
ADA Compliant Lowered Floor Minivans

requirements of 49 CFR Part 26 apply to the agreement. In this regard, all recipients or Vendors shall take all necessary and reasonable steps in accordance with 49 CFR Part 26 to ensure that DBEs have the maximum opportunity to compete for and perform contracts. Recipients and their Vendors shall not discriminate on the basis of race, color, national origin, or sex in the award and performance of U.S. Department of Transportation-assisted contracts.

- 3) The manufacturer of transit vehicles shall certify that it has complied with the requirements of 49 CFR Part 26 (March 4, 1999), Section 26.49, "Transit Vehicle Manufacturers". This certification shall be submitted with responses to this solicitation on **Bid Form #3**.
- 4) The Vendor shall make good faith efforts to replace a DBE subcontractor that is unable to perform, with another DBE subcontractor.
- 5) Where the Vendor is found to have failed to exert sufficient reasonable and good faith efforts to involve DBEs in the work provided, the Division may declare the Vendor noncompliant and in breach of contract.
- 6) The Vendor will keep records and documents for a reasonable time following performance of this contract to indicate compliance with the Division DBE Program. These records and documents will be made available at reasonable times and places for inspection by any authorized representative of the Division and will be submitted to the Division upon request.
- 7) The awarded Vendor agrees to include the following assurance in every subcontract it signs relevant to this contract: The Vendor and each Third Party Subcontractor must not discriminate on the basis of race, color, national origin, or sex in the award and performance of any FTA or U.S. DOT-assisted sub-agreement, third party contract, and third party subcontract, as applicable, and the administration of its DBE program or the requirements of 49 CFR Part 26.

The Vendor and each third party subcontractor must take all necessary and reasonable steps under 49 CFR Part 26 to ensure nondiscrimination in the award and administration of U.S. DOT-assisted sub-agreements, third party contracts and third party subcontracts, as applicable.

Failure by the Vendor and any of its third party contracts or third party subcontractors to carry out the requirements of this subparagraph 13.d(4)(b) is a material breach of this contract, and

REQUEST FOR QUOTATION
ADA Compliant Lowered Floor Minivans

The following remedies, or such other remedy as the Division of Public Transit deems appropriate, include, but are not limited to, withholding payments; assessing sanctions; liquidated damages; and/or disqualifying the Vendor from future bidding as non-responsible.

- 9.4 **Prohibited Interest** – No employee, officer, board member, agent or their family members of the Division may participate in the selection, award or administration of a contract supported by Federal funds if a real or apparent conflict of interest is involved. Such a conflict could arise when any of the parties mentioned above have a financial or other interest in the Vendor selected for the contract.
- 9.5 **Civil Rights Requirements** – In connection with the execution of this contract, the following requirements will apply:
- A. **Nondiscrimination**. In accordance with Title VI of the Civil Rights Act of 1964, As amended, 42 U.S.C. § 2000d, *et seq.*, Age Discrimination Act of 1975, as amended, 42 U.S.C. §6101, *et. seq.*, Americans With Disabilities Act of 1990, as amended, 42 U.S.C. § 12101, *et. seq.*, and Federal transit law at 49 U.S.C. §5332, as amended, the Vendor agrees that it will not discriminate against any employee or applicant for employment on the basis of race, color, religion, national origin, sex, age or disability. In addition, the Vendor agrees to comply with any other applicable Federal statutes that may be signed into law or regulations that may be promulgated.
- B. **Equal Employment Opportunity**. The following equal employment opportunity requirements apply to the underlying contract:
- 1) **Race. Color. Religion. National Origin. Sex. Disability. Age. Sexual Orientation. Gender Identity or Status as a Parent.** In accordance with Title VI of the Civil Rights Act of 1964, as amended, 42 U.S.C. § 2000e, *et seq.*, and Federal transit laws at 49 U.S.C. § 5332, the Vendor agrees to comply with all applicable equal employment opportunity requirements of the U.S. Department of Labor (US DOL) regulations, “Office of Federal Contract Compliance Programs, Equal Employment Opportunity, Department of Labor,” 41 C.F.R. Parts 60 *et seq.*, (which implement Executive Order Number 11246, “Equal Employment Opportunity”, as amended by Executive Order Number 11375, “Amending Executive Order 11246 Relating to Equal Employment Opportunity,” 42 U.S.C. § 2000e note), and with any applicable Federal statutes, executive orders, regulations, and Federal policies that may in the future affect construction activities undertaken in the course of the Project. The Vendor agrees to take affirmative

REQUEST FOR QUOTATION
ADA Compliant Lowered Floor Minivans

action to ensure that applicants are employed, and that employees are treated during their employment, without regard to their race, color, religion, national origin, sex, disability, age, sexual orientation, gender identity or status as a parent. Such action shall include, but not be limited to, the following: employment, upgrading, demotion or transfer, recruitment or recruitment advertising, layoff or termination; rates of pay or other forms or compensation; and selection for training, including apprenticeship. In addition, the Vendor agrees to comply with any implementing requirements FTA may issue.

- C. The Vendor also agrees to include these requirements in each subcontract financed in whole or in part with Federal assistance provided by FTA, modified only if necessary to identify the affected parties.

9.6 **Buy America Certification** – Vendor agrees to comply with 49 U.S.C. § 5323(j) and 49 CFR Part 661, which provides that Federal funds may not be obligated unless steel, iron, and manufactured products used in FTA-funded projects are produced in the United States, unless a waiver has been granted by FTA or the product is subject to a general waiver. General waivers are listed in 49 CFR 661.7 and include, microcomputer equipment, software, and small purchases (currently less than \$150,000) made with capital, operating, or planning funds. Separate requirements for rolling stock are set out at 49 CFR 661.11. Rolling stock not subject to a general waiver must be manufactured in the United States and have a 60 percent domestic content.

- A. A bidder must submit to the Division the appropriate Buy America certification on Bid Form #4 with all bids on FTA-funded contracts, except those subject to a general waiver. Per FTA requirements, bids that are not accompanied by a completed Buy America certification must be rejected as non-responsive. This requirement does not apply to lower tier subcontractors.
- B. Should the Vendor be declared responsive and low bid, pursuant to Pre-Award and Post Delivery Audit Requirements, the Division will require the Vendor to submit documentation (prior to any award) that lists:
- 1) Component and sub-component parts of the rolling stock to be purchased identified by manufacturer of the parts, their country of origin and costs; and
 - 2) The location of the final assembly point for the rolling stock, including a description of the activities that will take place at the final assembly point and the cost of final assembly.

REQUEST FOR QUOTATION
ADA Compliant Lowered Floor Minivans

- 3) The Vendor shall submit one manufacturer's Federal Motor Vehicle Safety Standards (FMVSS) self-certification sticker providing information that the vehicle quoted complies with relevant FMVSS, or Manufacturer's certified statement that the contracted vehicles will not be subject to FMVSS regulations.
 - 4) Vendor shall submit evidence that it will be capable of meeting the bid specifications.
- C. As required by the Post Delivery Audit Requirement, any successful vendor will be required to furnish the following prior to any completed vehicle being placed into service or before any payment can be made:
- 1) Actual component and sub-component parts of the rolling stock provided, identified by manufacturer of the parts, their country of origin and costs; and
 - 2) Actual location of the final assembly point for the rolling stock provided, including a description of the activities that took place at the final assembly point and the actual cost of final assembly.
- 9.7 **Federal Regulation Changes** – Vendor shall at all times comply with all applicable FTA regulations, policies, procedures and directives, including without limitation those listed directly or by reference in the Master Agreement (FTA MA(22) dated October 1, 2015) <http://www.fta.dot.gov> between the WV Department of Transportation, Division and FTA, as they may be amended or promulgated from time to time during the term of this contract. Vendor's failure to so comply shall constitute a material breach of this contract.
- 9.8 **Debarment and Suspension** – This contract will comply with the requirements of 2 CFR Part 180, subpart C as adopted and supplemented by U.S. DOT regulations at 2 CFR Part 1200. Vendor is required to submit Bid Forms #6 & #7 with bid.

The Division will not enter into any arrangement to participate in the development or implementation of a contract with any Vendor that is debarred or suspended except as authorized by Executive Orders No. 12549, "Uniform Suspension, Debarment or Exclusion of Participant from Procurement or Non-procurement Activity," October 13, 1994, 31 U.S.C. § 6101 note, as amended by Executive Order No. 12689, "Debarment and Suspension," August 16, 1989, 31 U.S.C. § 6101 note, and other applicable federal laws, regulations, or guidance regarding participation with debarred or suspended Vendors.

The Division will review the U.S. GSA "System for Award Management – Lists of parties Excluded from Federal Procurement and Non-procurement Program," <https://www.sam.gov>,

REQUEST FOR QUOTATION
ADA Compliant Lowered Floor Minivans

As required by U.S. DOT regulations, 2 CFR Part 1200. If the Vendor's name is on the list, the Division cannot enter into a contract with a Vendor on the debarred list.

Should an approved Vendor have subcontracts, it is required to include similar provisions in each subcontract and review the SAM at <https://www.sam.gov>, to determine that the subcontractor is not on the debarred or suspended list.

- 9.9 **Restrictions on Lobbying** – Every Vendor who applies or bids for an award of \$100,000 or more shall file the certification of **Bid Form #9** required by 49 CFR Part 20, "New Restrictions on Lobbying." Each tier certifies to the tier above that it will not and has not used Federal appropriated funds to pay any person or organization for influencing or attempting to influence an officer or employee of any agency, a member of Congress, officer or employee of Congress, or an employee of a member of Congress in connection with obtaining any Federal contract, grant or any other award covered by 31 U.S.C. § 1352. Each tier shall also disclose the name of the registrant under the Lobbying Disclosure Act of 1995 who has made lobbying contacts on its behalf with non-Federal funds with respect to that Federal contract, grant or award covered by 31 U.S.C. §1352. Such disclosures are forwarded from tier to tier, up to the Division.
- 9.10 **Environmental Regulations** – The Vendor agrees it will not use any violating facilities, will report the use of facilities placed on or likely to be placed on the U.S. EPA "List of Violating Facilities," will report violations of use of prohibited facilities to the Division who will in turn report each violation to FTA and the appropriate EPA Regional Office and will comply with the inspection and other requirements issued pursuant to the Environmental Protection Agency (EPA) regulations (40 CFR, Part 15), which prohibits the use under nonexempt federal contracts, grants, or loans of facilities included on the EPA list of violating facilities.
- 9.11 **Clean Air** – The Vendor agrees to comply with all applicable standards, orders, or regulations issued pursuant to the Clean Air Act, as amended, 42 U.S.C. § 7606 and other requirements of the Clean Air Act, as amended, 42 U.S.C. §§ 7401 – 7671q. The Vendor agrees to report each violation to the Division and understands and agrees that the Division will, in turn, report each violation as required to FTA and the appropriate EPA Regional Office.
- The Vendor also agrees to include these requirements in each subcontract exceeding \$100,000 financed in whole or in part with Federal assistance by FTA.
- 9.12 **Clean Water** – The Vendor agrees to comply with all applicable standards, orders, or regulations issued pursuant to Section 508 of the Clean Water Act, as amended, 33 U.S.C. § 1368, and other provisions of the Clean Water Act, as amended, U.S.C. 33 §§1251 – 1377. The Vendor agrees to report each violation

REQUEST FOR QUOTATION
ADA Compliant Lowered Floor Minivans

to the Division and understands and agrees that the Division will, in turn, report each violation as required to FTA and the appropriate EPA Regional Office.

The Vendor also agrees to include these requirements in each subcontract exceeding \$100,000 financed in whole or in part with Federal assistance provided by FTA.

- 9.13 **Energy Conservation Requirements** – The Vendor agrees to comply with mandatory standards and policies relating to energy efficiency which are contained in the State Energy Conservation Plan issued in compliance with the Energy Policy and Conservation Act.
- 9.14 **Contract Work Hours and Safety Standards Act** – The Vendor shall comply with Section 102 of the Contract Work Hours and Safety Standards Act (40 USC §§ 3701 *et seq.*, esp. § 3702) as supplemented by Department of Labor Regulations (29 CFR, § 5 & 29 CFR § 1926) as they involve the employment of mechanics and laborers.
- A. Overtime Requirements – No Vendor or subcontractor for any part of the contract work which may require or involve the employment of laborers or mechanics shall require or permit any such laborer or mechanic in any workweek in which he or she is employed on such work to work in excess of forty (40) hours in such workweek unless such laborer or mechanic receives compensation at a rate not less than one and one-half times the basic rate of pay for all hours worked in excess of forty (40) hours in such workweeks.
- B. Violation; Liability for Unpaid Wages; Liquidated Damages – In the event of any violation of the clause set forth in paragraph A of this section, the Vendor and any subcontractor responsible therefore shall be liable for the unpaid wages. In addition, such Vendor and subcontractor shall be liable to the United States for liquidated damages. Such liquidated damages shall be computed with respect to each individual laborer or mechanic, including watchmen and guards, employed in violation of the clause set forth in paragraph A of this section, in the sum of \$10 for each calendar day on which such individual was required or permitted to work in excess of the standard workweek of forty (40) hours without payment of the overtime wages required by the clause set forth in paragraph A of this section.
- C. Withholding for Unpaid Wages and Liquidated Damages – The Division shall upon its own action or upon written request of an authorized representative of the Department of Labor withhold or cause to be withheld, from any moneys payable on account of work performed by the Vendor or subcontractor under any such contract or any other Federal

REQUEST FOR QUOTATION
ADA Compliant Lowered Floor Minivans

contract with the same prime Vendor, or any other federally-assisted contract subject to the Contract Work Hours and Safety Standards Act, which is held by the same prime Vendor, such sums as may be determined to be necessary to satisfy any liabilities of such Vendor or subcontractor for unpaid wages and liquidated damages as provided in the clause set forth in paragraph B of this section.

- D. Subcontracts – The Vendor or subcontractor shall insert in any subcontracts the clauses set forth in this section and also a clause requiring the subcontractors to include these clauses in any lower tier subcontracts. The prime Vendor shall be responsible for compliance by any subcontractor or lower tier subcontractor with the clauses set forth in this section.
- E. Payrolls and Basic Records – Payrolls and basic records relating thereto shall be maintained by the Vendor during the course of the work and preserved for a period of three (3) years thereafter for all laborers and mechanics working at the site of the work (or under the United States Housing Act of 1937, or under the Housing Act of 1949, in the construction or development of the project). Such records shall contain the name, address, and social security number of each such worker, his or her correct classification, hourly rates of wages paid (including rates of contributions or costs anticipated for bona fide fringe benefits or cash equivalents thereof of the types described in Section 1(b)(2)(B) of the Davis-Bacon Act), daily and weekly number of hours worked, deductions made and actual wages paid. Whenever the Secretary of Labor has found under 29 CFR .5(a)(1)(iv) that the wages of any laborer or mechanic include the amount of any costs reasonably anticipated in providing benefits under a plan or program described in Section 1(b)(2)(B) of the Davis-Bacon Act, the Vendor shall maintain records which show that the commitment to provide such benefits is enforceable, that the plan or program is financially responsible, and that the plan or program has been communicated in writing to the laborers or mechanics affected, and records which show the costs anticipated or the actual cost incurred in providing such benefits.

Vendors employing apprentices or trainees under approved programs shall maintain written evidence of the registration of apprenticeship programs and certification of the training programs, the registration of the apprentices and trainees, and the ratios and wage rates prescribed in the applicable programs.

- 9.15 **Hold Harmless** – The Vendor agrees to protect, defend, indemnify and hold the State of West Virginia, the Division, its officers, employees and agents free and harmless from and against any and all losses, penalties, damages, settlements, costs, charges, professional fees or other expenses or liabilities of every kind and

REQUEST FOR QUOTATION
ADA Compliant Lowered Floor Minivans

character arising out of or relating to any and all claims, liens, demands, obligations, actions, proceedings or causes of action of every kind and character in connection with or arising directly or indirectly out of this Contract and/or the performance hereof. Without limiting the generality of the foregoing, and all such claims, etc., relating to personal injury, infringement of any patent, trademark, copyright (or application for any thereof) or of any other tangible or intangible personal or property right, or actual or alleged violation of any applicable statute, ordinance, administrative order, rule or regulation, or decrees of any court, shall be included in the indemnity hereunder. The Vendor further agrees to investigate, handle, respond to, provide defense for and defend any such claims, etc., at his/her sole expense and agrees to bear all other costs and expenses related thereto, even if such claim is groundless, false or fraudulent.

9.16 Program Fraud and False or Fraudulent Statements and Related Acts

The Vendor acknowledges that the provisions of the Program Fraud Civil Remedies Act of 1986, as amended 31 U.S.C. §§ 3801 *et seq.* and U.S. Department of Transportation regulations, "Program Fraud Civil Remedies," 49 C.F.R. Part 31, apply to its actions pertaining to this Contract. Upon execution of the underlying contract, the Vendor certifies or affirms the truthfulness and accuracy of any statement it has made, it makes, it may make, or causes to be made, pertaining to the underlying contract or the FTA assisted project for which this Contract work is being performed. In addition to other penalties that may be applicable, the Vendor further acknowledges that if it makes, or causes to be made, a false, fictitious, or fraudulent claim, statement, submission, or certification, the Federal Government reserves the right to impose the penalties of the Program Fraud Civil Remedies Act of 1986 on the Vendor to the extent the Federal Government deems appropriate.

The Vendor also acknowledges that if it makes, or causes to be made, a false, fictitious, or fraudulent claim, statement, submission, or certification to the Federal Government under a contract connected with a project that is financed in whole or in part with Federal assistance originally awarded by FTA under the authority of 49 U.S.C. § 5307, the Government reserves the right to impose the penalties of 18 U.S.C. § 1001 and 49 U.S.C. § 5307(n)(1) on the Vendor, to the extent the Federal Government deems appropriate.

The Vendor agrees to include the above two clauses in each subcontract financed in whole or in part with Federal assistance provided by FTA. It is further agreed that the clauses shall not be modified, except to identify the subcontractor who will be subject to the provisions.

9.17 Incorporation of FTA Terms

The preceding provisions include, in part, certain Standard Terms and Conditions required by the U.S. Department of Transportation, whether or not expressly set

REQUEST FOR QUOTATION
ADA Compliant Lowered Floor Minivans

forth in the preceding Contract provisions. All contractual provisions required by DOT, as set forth in FTA Circular 4220.1F, dated November 1, 2008, and are hereby incorporated by reference. Anything to the contrary herein notwithstanding, all FTA mandated terms shall be deemed to control in the event of a conflict with other provisions contained in this Contract. The Vendor shall not perform any act, fail to perform any act, or refuse to comply with any DPT requests which would cause DPT to be in violation of the FTA terms and conditions.

9.18 Access to Records

The Vendor agrees to permit DPT, the Secretary of the US DOT and the Comptroller General of the United States, or their authorized representatives, to inspect all Contract work, materials, payrolls and other data and records with regard to the Contract. The Vendor also agrees to permit an audit of the books, records, and accounts of the Vendor and its subcontractors.

9.19 Accessibility

Vendor agrees that any vehicles provided shall be in accordance with the 42 U.S.C. Sections 12101 *et seq.*, and US DOT regulations, "Transportation Services for Individuals with Disabilities Act (ADA)," 49 CFR Part 37; and Joint U.S. Architectural and Transportation Barriers Compliance Board (U.S. ATBCB) and U.S. DOT regulations, "Americans with Disabilities (ADA) Accessibility Specifications for Transportation Vehicles," 36 CFR Part 1192 and 49 CFR Part 38.

9.20 Air Pollution and Fuel Economy

Vendor is to ensure compliance with applicable Federal air pollution control and fuel economy regulations, such as EPA regulations, "Control of Air Pollution from Mobile Sources," 40 CFR Part 85; EPA regulations, "Control of Emissions from New and In-Use Vehicles," 40 CFR Part 86; and EPA regulations, "Fuel Economy and Greenhouse Gas Exhaust Emissions of Motor Vehicles" 40 CFR Part 600.

9.21 Bid Protest Procedures

Vendors have the option of protesting certain decisions made by the Purchasing Division. Please refer to the following link for Vendor Protest Procedures under Section 6.8.

<http://www.state.wv.us/admin/purchase/vrc/vpg/VendorProcurementGuide.pdf>

REQUEST FOR QUOTATION
ADA Compliant Lowered Floor Minivans

9.22 Appeals to the Federal Transit Administration (FTA)

Under the Federal Transit Administration's Circular 4220.1F, the Federal Transit Administration's (FTA's) appeals process for reviewing protests of a recipient's procurement decisions are:

- 1) Requirements for the Protester – The protester must:
 - a) Qualify as an “Interested Party” – Only an “interested party” qualifies for FTA review of its appeal. An “interested party” is a party that is an actual or prospective bidder or offeror whose direct economic interest would be affected by the award or failure to award the contract at issue.
 - i) Subcontractors – A subcontractor does not qualify as an “interested party” because it does not have a direct economic interest in the results of the procurement.
 - ii) Consortia//Joint Ventures/Partnerships/Teams – An established consortium, joint venture, partnership, or team that is an actual bidder or offeror and is acting in its entirety, would qualify as an “interested party” because it has a direct economic interest in the results of the procurement. An individual member of a consortium, joint venture, partnership, or team, acting solely in its individual capacity, does not qualify as an “interested party” because it does not have a direct economic interest in the results of the procurement.
 - iii) Associations or Organizations – An association or organization that does not perform contracts does not qualify as an “interested party” because it does not have a direct economic interest in the results of the procurement.
 - b) Exhaust Administrative Remedies – The protester must exhaust its administrative remedies by pursuing the WV Purchasing Division protest procedures to completion before appealing their decision to FTA.
 - c) Appeal Within Five (5) Days – The protester must deliver its appeal to the FTA Regional Administrator, Region III, 1760 Market Street, Suite 500, Philadelphia, PA, 19103-4124 within five (5) working days of the date when the protester has received actual or constructive notice of the WV Purchasing Division's final decision. Likewise, the protester must provide its appeal to the same address within five (5) working days of the date when the protester has identified other grounds for appeal to FTA. For example, other grounds for appeal include the DPT's failure to have or failure to comply with the WV Purchasing Division's protest procedures or failure to review the protest.

REQUEST FOR QUOTATION
ADA Compliant Lowered Floor Minivans

- 2) Extent of FTA Review – FTA limits its reviews of protests to:
- a) Failure of DPT to have or adhere to WV Purchasing Division written bid protest procedures, or failure of DPT to review a complaint or protest.
 - b) Alleged violations on other grounds are under the jurisdiction of the appropriate State or local administrative authorities.
 - c) Alleged violations of a specific Federal Law or regulation that provides an applicable complaint procedure shall be submitted and processed in accordance with that Federal Law or regulation. See, e.g., Buy America Requirements, 49 C.F.R. Part 661 (Section 661.15); Participation by Minority Business Enterprise in Department of Transportation Programs, 49 C.F.R. Section 26.89.

FTA will exercise discretionary jurisdiction over those appeals involving issues important to FTA's overall public transportation program. FTA will refer violations of Federal law for which it does not have primary jurisdiction to the Federal authority having proper jurisdiction.

- 3) FTA Determinations to Decline Protest Reviews – FTA's determination to decline jurisdiction over a protest does not mean that FTA approves of or agrees with WV Purchasing Division's decision or that FTA has determined the contract is eligible for Federal participation. FTA's determination means only that FTA does not consider the issues presented to be sufficiently important to FTA's overall program that FTA considers a review to be required.

10. ORDERING AND PAYMENT TO VENDOR

10.1 ORDERING:

Vendor shall accept orders by regular mail, facsimile, e-mail, or any other written forms of communication.

10.2 Payment

When submitting invoices for payment to the Division, the Vendor shall be required to provide an original typed invoice. The following items shall appear on the invoice:

- 1) Vendor's Federal Employee Identification Number (FEIN)
- 2) Order number

REQUEST FOR QUOTATION
ADA Compliant Lowered Floor Minivans

- 3) Invoice should reflect the base vehicle cost and any applicable options With unite cost. NOTE: Two invoices shall be submitted for each vehicle , one for 90% and one for 10%.
- 4) Submit all invoices to:
Division of Multimodal Transportation Facilities-Public Transit
Building 5, Room 663
1900 Kanawha Blvd., East
Charleston, West Virginia 25305
- 10.2.1 Payment of 90% of the total cost shall be paid upon conditional acceptance of the vehicle(s).
- 10.2.2 Conditional acceptance of the vehicle(s) by the Division shall be made upon completion of inspection by the Division of Public Transit under Section 17 of this RFQ.
- 10.2.3 Under the conditional acceptance of the vehicle(s) provided, the Division of Public Transit shall retain 10% of the total cost per vehicle until all vehicles provided have been in actual service for thirty (30) days.
- 10.2.4 In the event any vehicle is found to be unacceptable during the thirty (30) day period of conditional acceptance, the Division shall furnish to the Vendor, in writing, a letter of non- acceptance detailing any and all deficiencies.
- 10.2.5 Final acceptance on each vehicle shall be made by the Division of Public Transit in writing upon completion of the period of conditional acceptance and/or after any and all deficiencies have been corrected.
- 10.2.6 Final acceptance shall be made on each individual vehicle provided. (Some vehicles may be accepted, while acceptance of others remains pending.)
- 10.2.7 Final acceptance of each vehicle shall be provided in writing by the Director of the Division or his/her authorized representative.
- 10.2.8 All warranties as described in this contract shall begin with the first day after the date of final acceptance of each vehicle. **Vendor shall furnish Notification of Delayed Delivery Date of In-Transit Mileage Accumulation Forms for completion by the Division upon acceptance of the vehicle.**
- 10.2.9 Prompt Payment – The prime Vendor agrees to pay each sub-contractor

REQUEST FOR QUOTATION
ADA Compliant Lowered Floor Minivans

under this prime contract for satisfactory performance of its contract no later than fifteen (15) days from the receipt of each payment the prime Vendor receives from the Division. The Vendor agrees further to return retainage payments to each sub-contractor within fifteen (15) days after the sub-contractor's work is satisfactorily completed. Any delay of postponement of payment from the above referenced time frame may occur only for good cause following written approval from the Division. This clause applies to both DBE and non-DBE sub-contractors.

11. DELIVERY AND RETURN:

11.1 Delivery Time and Location: Vendors shall specify approximate delivery dates when submitting bids. Delivery of the vehicle shall be completed within 150 days after receipt of executed contract documents. Vendor shall ship all orders in accordance with the above schedule and shall not hold orders until a minimum delivery quantity is met.

11.2 Late Delivery: The Division must be notified in writing if delivery is delayed for any reason. The request for extension must be received by the Division no less than ten (10) days prior to the originally planned vehicle delivery date and must include detailed justification for the length of the time extension. Any delay in delivery that could cause harm to an Agency will be grounds for cancellation of the delayed order, and/or obtaining the items ordered from a third party.

Any Agency seeking to obtain items from a third party under this provision must first obtain approval of the Purchasing Division.

11.3 Delivery shall be FOB destination to designated transit provider or:

Kanawha Valley Regional Transit Authority (KRT)
1550 4th Avenue,
Charleston, WV 25324

Vendor must contact KRT 24 hours before delivery at 304-343-7594. Delivery will be accepted Monday through Friday, between 9 a.m. and 2 p.m. exclusive of State holidays.

Any delay in delivery resulting from the common carriers operations, accidents, or mechanical failures in route shall be construed as a cause beyond the Vendor's control.

However, the Vendor shall have the responsibility of releasing the vehicle to the common carrier in time to reach the delivery site under normal delivery conditions.

11.4 In case the delivery of the complete vehicle shall be necessarily delayed because of

REQUEST FOR QUOTATION
ADA Compliant Lowered Floor Minivans

strike, Injunction, civil disturbance, government controls, or by reason of any cause or circumstances beyond the control of the Vendor, as detailed in writing by the Vendor, the term of completion of delivery shall be extended by a number of days to be determined in each instance by mutual agreement of the Division of Public Transit and Vendor.

- 11.5** If the vehicle is delivered over-the-road, a written report shall be submitted by the driver to the Division listing all incidents and unusual vehicle performance during the trip.

Should any service or repair be required during delivery, a comprehensive report shall be submitted to the Executive Director of the Division describing the nature of the service or repair and the cause.

- 11.6** Prior to acceptance, the Vendor shall have total risk of loss of the vehicle, including any damage sustained during the Vendor's driveway operation. Drivers shall keep a maintenance log enroute and it shall be delivered to the Division with the vehicle.

12. ACCEPTANCE TESTS

12.1 Responsibility

Fully-documented tests shall be conducted on each production vehicle following manufacture to determine its acceptance to the Division. These acceptance tests shall include pre-delivery inspections and testing by the Division after the vehicles have been delivered.

12.2 Pre-Delivery Tests

The Vendor shall conduct acceptance tests at its plant on each vehicle following completion of manufacture and before delivery to the Division. These pre-delivery tests shall include visual and measured inspections, as well as testing the total vehicle operation. The tests shall be documented. Additional tests may be conducted at the Vendor's discretion to ensure that the completed vehicles have attained the desired quality and have met the requirements of Section 3: Specifications. This additional testing shall be recorded on appropriate test forms provided by the Vendor.

The pre-delivery tests will be scheduled and conducted with sufficient notice so that they may be witnessed by the resident inspectors, who may accept or reject the results of the tests. The results of pre-delivery tests, and any other tests, will be filed with the assembly inspection records for each vehicle. The under-floor equipment will be made available for inspection by the

REQUEST FOR QUOTATION
ADA Compliant Lowered Floor Minivans

resident inspectors, using a hoist. A scaffold, or elevated platform will be provided by the Vendors to easily and safely inspect vehicle roofs. Delivery of each vehicle will require written authorization of a resident inspector. Authorization forms for the release of each vehicle for delivery will be provided by the Vendor. An executed copy of the authorization will accompany the delivery of each vehicle.

12.3 Inspection - Visual and Measured

Visual and measured inspections shall be conducted with the vehicle in a static condition. The purpose of the inspection testing is to verify overall dimensional and weight requirements, to verify that required components are included and are ready for operation, and to verify that components and subsystems that are designed to operate with the vehicle in a static condition do function as designed.

13. Total Vehicle Operation

Total vehicle operations shall be evaluated during road tests. The purpose of the road tests is to observe and verify the operation of the vehicle as a system and to verify the functional operation of the subsystem that can be operated only while the vehicle is in motion.

Each vehicle shall be driven for a minimum of 15 miles during the road tests. Observed defects shall be recorded on the test forms. The vehicle shall be retested when defects are corrected and adjustments are made. This process shall continue until defects or required adjustments are no longer detected. Results shall be pass/fail for these vehicle operation tests.

14. Final Pre-Delivery Inspection: Prior to delivery, all vehicles must be thoroughly inspected and serviced in compliance with the manufacturer's prescribed procedures which includes but is not limited to:

- a. Complete vehicle lubrication;
- b. Confirm oil level, fill crank case as needed, top off all fluids;
- c. Adjust engine to proper operating condition;
- d. Verify tire pressure and correct as necessary;
- e. Check front end alignment or four wheel alignment, perform alignment, and balance all tires;

REQUEST FOR QUOTATION
ADA Compliant Lowered Floor Minivans

- f. Wash/Clean interior and exterior of vehicle. Remove all unnecessary tags, stickers (including window stickers), papers, tags, etc.
- g. Upon delivery, the vehicles fuel tanks shall be full of fuel;
- h. Affix a valid West Virginia Inspection Sticker to the windshield. The vehicle must be inspected in the month delivered.
- i. No dealer insignia or other advertising shall be affixed to the vehicle or appear on any accessory such as mud flaps, bumpers, deck lids, etc. Vehicles delivered with such advertising will be rejected;
- j. Perform operational checks which will cover all controls, systems, and devices, doors, windows, accessories, and road testing of the completed vehicle. Vehicle shall be driven at various speeds; brakes tested for dependability, vehicle checked for rattles, squeaks and must be in compliance with pre-delivery inspection/servicing procedures and make adjustments as necessary.

15. Post-Delivery Tests The Division shall, within fifteen (15) calendar days of notice from Vendor that vehicle is ready to be inspected for conditional acceptance, proceed with its inspection of vehicle for conditional acceptance. The Division will conduct acceptance tests on each delivered vehicle. The purpose of these tests is to identify defects that have become apparent between the time of vehicle release and delivery to the Division. The post-delivery tests shall include visual inspection and vehicle operations. The road tests for total vehicle operation are similar to those conducted at the Vendor's plant. Operational deficiencies of each vehicle shall be identified and recorded.

Vehicles that fail to pass the post-delivery tests are subject to non-acceptance. The Division shall record details of all defects and shall notify the Vendor of non-acceptance of each vehicle within 5 days after completion of the tests.

16. Conditional Acceptance of Vehicle's The vehicle shall undergo the Division's acceptance test. If the vehicle passes these tests, conditional acceptance of the vehicle by the Division occurs on the fifteenth day after delivery. Acceptance may occur earlier if the Division notifies the Vendor of early acceptance. If the vehicle fails these tests, it shall not be accepted until the repairs have been made.

16.1 Repairs After Non-Acceptance

The Division may require the Vendor, or its designated representative, to perform the repairs after non-acceptance or the work may be done by the Transit Authority or Recipient Agency's personnel with reimbursement by the Vendor.

REQUEST FOR QUOTATION
ADA Compliant Lowered Floor Minivans

17.1.1 Repairs by Vendor

If the Transit Authority or Recipient Agency requires the Vendor to perform repairs after non-acceptance of the vehicle, Vendor's representative must begin work within five (5) working days after receiving notifications from the Division or Transit Authority of failure of acceptance tests. The Transit Authority or Recipient Agency shall make the vehicle available to complete repairs timely with the Vendor's repair schedule.

The Vendor shall provide, at its own expense, all spare parts, tools and space required to complete the repairs. At the Transit Authority or Recipient Agency's option, the Vendor may be required to remove the vehicle from their property. The repair procedure must be diligently pursued by the Vendor's representatives and the Vendor shall assume risk of loss while the vehicle is under its control.

17.1.2 Repairs by Transit Authority or Recipient Agency

- a) **Parts Used.** If the Transit Authority or Recipient Agency decides to perform the repairs after non-acceptance of the vehicle, it shall correct or repair the defect and any related defects using Vendor specified parts available from its own stock or those supplied by the Vendor specifically for this repair.

Monthly, or at a period to be mutually agreed upon, reports of all repairs covered by this procedure shall be submitted by the Transit Authority or Recipient Agency to the Vendor for reimbursement or replacement of parts. The Vendor shall provide forms for these reports.

- b) **Vendor Supplied Parts.** If the Vendor supplies parts for repairs being performed by the Transit Authority or Recipient Agency, after non-acceptance of the vehicle, these parts shall be shipped prepaid to the Transit Authority or Recipient Agency from any source selected by the Vendor within ten (10) working days after receipt of the request for said parts, provided said parts are available for shipment.
- c) **Return of Defective Components.** The Vendor may request that parts covered by this provision be returned to the manufacturing plant. The total cost for this action shall be paid by the Vendor.
- d) **Reimbursement for Labor.** The Transit Authority or Recipient Agency shall be reimbursed by the Vendor for labor. The amount shall be determined by multiplying the number of actual "man-hours" straight wage rate plus 53 percent fringe benefits, plus the cost of towing in the

REQUEST FOR QUOTATION
ADA Compliant Lowered Floor Minivans

vehicle if such action was necessary. These wage and fringe benefit rates shall not exceed the rates in effect at the Transit Authority or Recipients Agency's service garage at the time the defect correction is made.

- e) Reimbursement for Parts. The Transit Authority or Recipient Agency shall be reimbursed by the Vendor for defective parts that must be replaced to correct the defect. The reimbursement shall include taxes where applicable and ten (10) percent handling cost.

- 16.1.3 Delivery Payment/Risk of Loss: Standard order delivery shall be F.O.B. destination to the Agency's designated location. Vendor shall include the cost of standard order delivery charges in its bid pricing/discount and is not permitted to charge the Agency separately for such delivery.

17. VENDOR DEFAULT:

- 17.1 The Following shall be considered a vendor default under this Contract.
 - 18.1.1 Failure to provide Contract Items in accordance with the requirements contained herein.
 - 18.1.2 Failure to comply with other specifications and requirements contained herein.
 - 18.1.3 Failure to comply with any laws, rules, and ordinances applicable to the Contract Services provided under this Contract.
 - 18.1.4 Failure to remedy deficient performance upon request.
- 17.2 The Following remedies shall be available to Agency upon default.
 - 18.2.1 Immediate cancellation of the Contract.
 - 18.2.2 Immediate cancellation of one or more release orders issued under this Contract.
- i. Any other remedies available in law or equity.

REQUEST FOR QUOTATION
ADA Compliant Lowered Floor Minivans

19. PROPOSED FLOOR PLANS

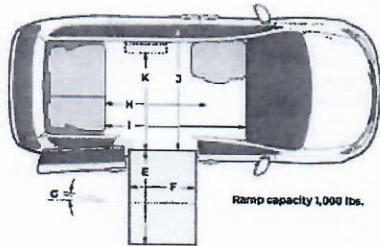
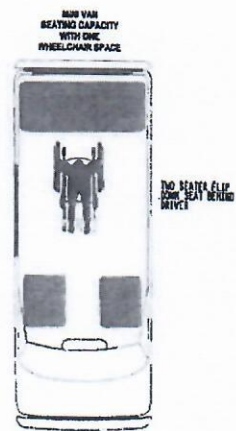

Revised 03/13/2024

REQUEST FOR QUOTATION
ADA Compliant Lowered Floor Minivans

20. **REQUIRED BID FORMS**

The following certifications must be properly **completed and furnished by the bidder as part of the bid**. Failure to submit any of these certifications **shall deem the bid non-responsive**.

A required documentation checklist has been provided for bidder's usage.

REQUEST FOR QUOTATION
ADA Compliant Lowered Floor Mini-Van

List of Suggested Vendors

Bus Service Inc.
3153 Lamb Avenue
Columbus, OH 43219

Central States Bus Sales, Inc.
361 United Court
Lexington, KY 40509

Midwest Transit Kankakee
146 Issert Drive
Kankakee, IL 60901

Mobil 1
2100 Washington Rd.
Canonsburg, PA 15317

Rohrer Bus Sales
1515 State Road
PO Box 100
Duncannon, PA 17020

Sonny Merryman Inc.
PO Box 495
Rustburg, VA 24588

Transportation Equipment Sales
P. O. Box 167230
Oregon, OH 43616

REQUEST FOR QUOTATION
ADA Compliant Lowered Floor Mini-Van

Appendix A: Frequently Asked Questions from Vendors

CRFQ 0810

Vendor Questions / Agency Responses:

***Please note that all of these questions may not pertain to the updated specifications of this current bid. If there are additional questions, please provide them and we will respond to the inquiries as soon as possible in order to complete the bidding process.**

REQUEST FOR QUOTATION
ADA Compliant Lowered Floor Mini-Van

Appendix B: Federal Clauses

FEDERAL CLAUSES

(where applicable)

1. No Government Obligation to Third Parties

- a. MOVTA and CONTRACTOR acknowledge and agree that, notwithstanding any concurrence by the Federal Government in or approval of the solicitation or award of the underlying contract, absent the express written consent by the Federal Government, the Federal Government is not a party to this contract and shall not be subject to any obligations or liabilities to MOVTA, CONTRACTOR, or any other party (whether or not a party to that contract) pertaining to any matter resulting from the underlying contract.
- b. The CONTRACTOR agrees to include the above clause in each subcontract financed in whole or in part with Federal assistance provided by FTA. It is further agreed that the clause shall not be modified, except to identify the SUBCONTRACTOR who will be subject to its provisions.

2. Program Fraud and False or Fraudulent Statements or Related Acts.

- a. The CONTRACTOR acknowledges that the provisions of the Program Fraud Civil Remedies Act of 1986, as amended, 31 U.S.C. § 3801 et seq. and U.S. DOT regulations, "Program Fraud Civil Remedies," 49 C.F.R. Part 31, apply to its actions pertaining to this Project. Upon execution of the underlying contract, the CONTRACTOR certifies or affirms the truthfulness and accuracy of any statement it has made, it makes, it may make, or causes to be made, pertaining to the underlying contract or the FTA assisted project for which this contract work is being performed. In addition to other penalties that may be applicable, the CONTRACTOR further acknowledges that if it makes, or causes to be made, a false, fictitious, or fraudulent claim, statement, submission, or certification, the Federal Government reserves the right to impose the penalties of the Program Fraud Civil Remedies Act of 1986 on the CONTRACTOR to the extent the Federal Government deems appropriate.
- b. The CONTRACTOR also acknowledges that if it makes, or causes to be made, a false, fictitious, or fraudulent claim, statement, submission, or certification to the Federal Government under a contract connected with a project that is financed in whole or in part with Federal assistance originally awarded by FTA under the authority of 49 U.S.C. Chapter 53, the Government reserves the right to impose the penalties of 18 U.S.C. § 1001 and 49 U.S.C. § 5323(l) or other applicable federal law on the CONTRACTOR, to the extent the Federal Government deems appropriate.
- c. The CONTRACTOR agrees to include the above two clauses in each subcontract financed in whole or in part with Federal assistance provided by FTA. It is further agreed that the clauses shall not be modified, except to identify the SUBCONTRACTOR who will be subject to the provisions.

3. Access to Records

The CONTRACTOR agrees to provide MOVTA, the FTA Administrator, the Comptroller General of the United States or any of their authorized representatives access to any books, documents, papers and records of the CONTRACTOR which are directly pertinent to this contract for the purposes of making audits, examinations, excerpts and transcriptions. The CONTRACTOR agrees to permit any of the foregoing parties to reproduce by any means whatsoever or to copy excerpts and transcriptions as

REQUEST FOR QUOTATION
ADA Compliant Lowered Floor Mini-Van

reasonably needed. In accordance with 2 CFR 200.333, the CONTRACTOR agrees to maintain all books, records, accounts and reports required under this contract for a period of not less than three years after the date of termination or expiration of this contract except in the event of litigation or settlement of claims arising from the performance of this Contract, in which case records shall be maintained until the disposition of all such litigation, appeals, claims or exceptions related thereto.

4. Federal Changes

The CONTRACTOR shall at all times comply with all applicable FTA regulations, policies, procedures and directives, including without limitation those listed directly or by reference in the Department of Transportation, Federal Transit Administration, Master Agreement between Purchaser and FTA, as they may be amended or promulgated from time to time during the term of this contract. The CONTRACTOR's failure to comply shall constitute a material breach of this contract.

5. Civil Rights

The following requirements apply to the underlying contract:

a. Nondiscrimination - In accordance with Title VI of the Civil Rights Act, as amended, 42 U.S.C. § 2000d, section 303 of the Age Discrimination Act of 1975, as amended, 42 U.S.C. § 6102, section 202 of the Americans with Disabilities Act of 1990, 42 U.S.C. § 12132, and Federal transit law at 49 U.S.C. § 5332, the CONTRACTOR agrees that it will not discriminate against any employee or applicant for employment because of race, color, creed, national origin, sex, age, or disability. In addition, the CONTRACTOR agrees to comply with applicable Federal implementing regulations and other implementing requirements FTA may issue.

b. Equal Employment Opportunity - The following equal employment opportunity requirements apply to the underlying contract:

(i) Race, Color, Creed, National Origin, Sex - In accordance with Title VII of the Civil Rights Act, as amended, 42 U.S.C. § 2000e, and Federal transit laws at 49 U.S.C. § 5332, the CONTRACTOR agrees to comply with all applicable equal employment opportunity requirements of U.S. Department of Labor (U.S. DOL) regulations, "Office of Federal Contract Compliance Programs, Equal Employment Opportunity, Department of Labor," 41 C.F.R. Parts 60 et seq., (which implement Executive Order No. 11246, "Equal Employment Opportunity," as amended by Executive Order No. 11375, "Amending Executive Order 11246 Relating to Equal Employment Opportunity," 42 U.S.C. § 2000e note), and with any applicable Federal statutes, executive orders, regulations, and Federal policies that may in the future affect construction activities undertaken in the course of the Project. The CONTRACTOR agrees to take affirmative action to ensure that applicants are employed, and that employees are treated during employment, without regard to their race, color, creed, national origin, sex, or age. Such action shall include, but not be limited to, the following: employment, upgrading, demotion or transfer, recruitment or recruitment advertising, layoff or termination; rates of pay or other forms of compensation; and selection for training, including apprenticeship. In addition, the CONTRACTOR agrees to comply with any implementing requirements FTA may issue.

(ii) Age - In accordance with section 4 of the Age Discrimination in Employment Act of 1967, as amended, 29 U.S.C. § 623 and Federal transit law at 49 U.S.C. § 5332, the CONTRACTOR agrees to

REQUEST FOR QUOTATION
ADA Compliant Lowered Floor Mini-Van

refrain from discrimination against present and prospective age. In addition, the CONTRACTOR agrees to comply with any implementing requirements FTA may issue.

(iii) Disabilities - In accordance with section 102 of the Americans with Disabilities Act, as amended, 42 U.S.C. § 12112, the CONTRACTOR agrees that it will comply with the requirements of U.S. Equal Employment Opportunity Commission, "Regulations to Implement the Equal Employment Provisions of the Americans with Disabilities Act," 29 C.F.R. Part 1630, pertaining to employment of persons with disabilities. In addition, the CONTRACTOR agrees to comply with any implementing requirements FTA may issue.

c. The CONTRACTOR also agrees to include these requirements in each subcontract financed in whole or in part with Federal assistance provided by FTA, modified only if necessary to identify the affected parties.

6. Disadvantaged Business Enterprises

a. It is the policy of the Department of Transportation and MOVTA that Disadvantaged Business Enterprises (DBEs) as defined in 49 C.F.R. part 26 shall have the maximum opportunity to participate in the performance of contracts financed in whole or part with federal funds under this contract. Consequently, the DBE requirement of 49 C.F.R. applies to this contract.

b. The CONTRACTOR or subcontractor shall not discriminate on the basis of race, color, natural origin, or sex in the performance of this contract. The CONTRACTOR shall carry out applicable requirements of 49 C.F.R. Part 26 in the award and administration of DOT assisted contracts. Failure by the contractor to carry out these requirements is a material breach of this contract, which may result in the termination of this contract or such other remedy as the recipient deems appropriate.

c. DBEs will be encouraged and afforded full opportunity to actively solicit information concerning this project and to submit bids and or proposals.

7. Incorporation of FTA Terms

The preceding provisions include, in part, certain Standard Terms and Conditions required by U.S. DOT, whether or not expressly set forth in the preceding contract provisions. All contractual provisions required by U.S. DOT, as set forth in FTA Circular 4220, 2 CFR 200.318, and subsequent revisions are hereby incorporated by reference. Anything to the contrary herein notwithstanding, all FTA-mandated terms shall be deemed to control in the event of a conflict with other provisions contained in this Agreement. The CONTRACTOR shall not perform any act, fail to perform any act, or refuse to comply with any MOVTA request, which would cause MOVTA to be in violation of the FTA terms and conditions.

8. Energy Conservation

The CONTRACTOR agrees to comply with mandatory standards and policies relating to energy efficiency which are contained in the state energy conservation plan issued in compliance with the Energy Policy and Conservation Act, 42 U.S.C. §§ 6321 *et seq.*

9. Termination

a. Termination for Convenience: MOVTA may terminate this contract, in whole or in part, at any time by written notice to the CONTRACTOR. The CONTRACTOR shall be paid its costs, including contract

REQUEST FOR QUOTATION
ADA Compliant Lowered Floor Mini-Van

closeout costs, and profit on work performed up to the time of termination. The CONTRACTOR shall promptly submit its termination claim to MOVTA to be paid. If the CONTRACTOR has any property in its possession belonging to MOVTA, the CONTRACTOR will account for the same, and dispose of it in the manner MOVTA directs.

b. Termination for Cause: If the CONTRACTOR does not deliver supplies in accordance with the contract delivery schedule, or, if the contract is for services, the CONTRACTOR fails to perform in the manner called for in the contract, or if the CONTRACTOR fails to comply with any other provisions of the contract, MOVTA may terminate this contract for default. Termination shall be effected by serving a notice of termination on the CONTRACTOR setting forth the manner in which the CONTRACTOR is in default. The CONTRACTOR will only be paid the contract price for supplies delivered and accepted, or services performed in accordance with the manner of performance set forth in the contract. If it is later determined by MOVTA that the CONTRACTOR had an excusable reason for not performing, such as a strike, fire, or flood, events which are not the fault of or beyond the control of the CONTRACTOR, MOVTA, after setting up a new delivery of performance schedule, may allow the CONTRACTOR to continue work, or treat the termination as a termination for convenience.

c. Opportunity to Cure: MOVTA in its sole discretion may, in the case of a termination for breach or default, allow the CONTRACTOR ten (10) business days in which to cure the defect. In such case, the notice of termination will state the time period in which cure is permitted and other appropriate conditions. If the CONTRACTOR fails to remedy to MOVTA's satisfaction the breach or default of any of the terms, covenants, or conditions of this Contract within ten (10) days after receipt by the CONTRACTOR of written notice from MOVTA setting forth the nature of said breach or default, MOVTA shall have the right to terminate the Contract without any further obligation to the CONTRACTOR. Any such termination for default shall not in any way operate to preclude MOVTA from also pursuing all available remedies against Contractor and its sureties for said breach or default.

10. Governmentwide Debarment and Suspension

By signing and submitting its bid or proposal, the offeror certifies as follows:

The certification in this clause is a material representation of fact relied upon by MOVTA. If it is later determined that the bidder or offeror knowingly rendered an erroneous certification, in addition to remedies available to MOVTA, the Federal Government may pursue available remedies, including but not limited to suspension and/or debarment. The bidder or offeror agrees to comply with the requirements of 49 CFR 29, Subpart C while this offer is valid and throughout the period of any contract that may arise from this offer.

The bidder or offeror further agrees to include a provision requiring such compliance in its lower tier covered transactions.

11. Notification Related to Fraud, Waste, Abuse, or Other Legal Matters

If a current or prospective legal matter that may affect the Federal Government emerges, the CONTRACTOR must promptly notify MOVTA so that it can notify the Federal Government. The types of legal matters that require notification include, but are not limited to, a major dispute, breach, default, litigation, or naming the Federal Government as a party to litigation or a legal disagreement in any forum for any reason. Matters that may affect the Federal Government include, but are not limited to, the

**REQUEST FOR QUOTATION
ADA Compliant Lowered Floor Mini-Van**

Federal Government's interests in the Award, the accompanying Underlying Agreement, and any Amendments thereto, or the Federal Government's administration or enforcement of federal laws, regulations, and requirements.

The CONTRACTOR agrees to include a similar notification requirement in subcontracts exceeding \$25,000 financed in whole or in part with federal assistance provided by FTA and must require each subcontractor to include an equivalent provision in its federally assisted subcontracts exceeding \$25,000.

12. Lobbying Restrictions

The CONTRACTOR agrees to:

- a. Refrain from using Federal assistance funds to support lobbying,
- b. Comply and assure the compliance of each SUBCONTRACTOR at any tier, with U.S. DOT regulations, "New Restrictions on Lobbying," 49 C.F.R. Part 20, modified as necessary by 31 U.S.C. § 1352.
- c. Comply with Federal statutory provisions to the extent applicable prohibiting the use of Federal assistance funds for activities designed to influence Congress or a State legislature on legislation or appropriations, except through proper, official channels.

13. Buy America

The CONTRACTOR agrees to comply with 49 U.S.C. 5323(j), 49 C.F.R. part 661, Pub. L. No. 117-58, and Pub. L. No. 117-58, §§ 70901-52 which provide that Federal funds may not be obligated unless all steel, iron, and manufactured products or construction materials used in FTA funded projects are produced in the United States unless a waiver has been granted by FTA or the product is subject to a general waiver.. General waivers are listed in 49 C.F.R. §661.7, and includes microcomputer equipment, software, and small purchases (currently less than \$150,000) made with capital, operating, or planning funds. Separate requirements for rolling stock are set out at 49 U.S.C. 5323(j)(2)(C) and 49 C.F.R. 661.11. Rolling stock must be assembled in the United States and have a 70 percent domestic content. A bidder or offeror must submit to the FTA recipient the appropriate Buy America certification with all bids or offers on FTA-funded contracts, except those subject to a general waiver. Bids or offers that are not accompanied by a completed Buy America certification must be rejected as nonresponsive. This requirement does not apply to lower-tier subcontractors.

14. Clean Air

- a. The CONTRACTOR agrees to comply with all applicable standards, orders or regulations issued pursuant to the Clean Air Act, as amended, 42 U.S.C. §§ 7401 through 7671q. The Contractor agrees to report each violation to the Purchaser and understands and agrees that the Purchaser will, in turn, report each violation as required to assure notification to FTA and the appropriate EPA Regional Office.
- b. The CONTRACTOR also agrees to include these requirements in each subcontract exceeding \$150,000 financed in whole or in part with Federal assistance provided by FTA.

15. Clean Water

- a. The CONTRACTOR agrees to comply with all applicable standards, orders or regulations issued pursuant to the Clean Water Act, as amended, 33 U.S.C. §§1251 through 1377. The Contractor agrees to

REQUEST FOR QUOTATION
ADA Compliant Lowered Floor Mini-Van

report each violation to the Purchaser and understands and agrees that the Purchaser will, in turn, report each violation as required to assure notification to FTA and the appropriate EPA Regional Office.

b. The CONTRACTOR also agrees to include these requirements in each subcontract exceeding \$150,000 financed in whole or in part with Federal assistance provided by FTA.

16. Breaches and Disputes

a. Disputes - Disputes arising in the performance of this Contract which are not resolved by agreement of the parties shall be decided in writing by the authorized representative of MOVTA. This decision shall be final and conclusive unless within ten (10) days from the date of receipt of its copy, the CONTRACTOR mails or otherwise furnishes a written appeal to MOVTA. In connection with any such appeal, the CONTRACTOR shall be afforded an opportunity to be heard and to offer evidence in support of its position. The decision of MOVTA shall be binding upon the CONTRACTOR and the CONTRACTOR shall abide by the decision.

b. Performance During Dispute - Unless otherwise directed by MOVTA, CONTRACTOR shall continue performance under this Contract while matters in dispute are being resolved.

c. Claims for Damages - Should either party to the Contract suffer injury or damage to person or property because of any act or omission of the party or of any of his employees, agents or others for whose acts he is legally liable, a claim for damages therefore shall be made in writing to such other party within a reasonable time after the first observance of such injury or damage.

d. Remedies - Unless this contract provides otherwise, all claims, counterclaims, disputes and other matters in question between MOVTA and the CONTRACTOR arising out of or relating to this agreement or its breach will be decided by arbitration if the parties mutually agree, or in a court of competent jurisdiction within the State of West Virginia.

e. Rights and Remedies - The duties and obligations imposed by the Contract Documents and the rights and remedies available thereunder shall be in addition to and not a limitation of any duties, obligations, rights and remedies otherwise imposed or available by law. No action or failure to act by MOVTA, Architect or CONTRACTOR shall constitute a waiver of any right or duty afforded any of them under the Contract, nor shall any such action or failure to act constitute an approval of or acquiescence in any breach thereunder, except as may be specifically agreed in writing.

17. Cargo Preference - Use of United States- Flag Vessels

To the extent applicable, the contractor agrees to comply with 46 U.S.C. §55305 and 46 C.F.R. Part 381 which includes, but is not limited to:

a. to use privately owned United States-Flag commercial vessels to ship at least 50 percent of the gross tonnage (computed separately for dry bulk carriers, dry cargo liners, and tankers) involved, whenever shipping any equipment, material, or commodities pursuant to the underlying contract to the extent such vessels are available at fair and reasonable rates for United States-Flag commercial vessels;

b. to furnish within 20 working days following the date of loading for shipments originating within the United States or within 30 working days following the date of loading for shipments originating outside the United States, a legible copy of a rated, "on-board" commercial ocean bill-of-lading in English for each shipment of cargo described in the preceding paragraph to the Division of National Cargo, Office of

REQUEST FOR QUOTATION
ADA Compliant Lowered Floor Mini-Van

Market Development, Maritime Administration, Washington, DC 20590 and to the FTA recipient (through the contractor in the case of a subcontractor's bill-of-lading.)
c. to include these requirements in all subcontracts issued pursuant to this contract when the subcontract may involve the transport of equipment, material, or commodities by ocean vessel.

18. Davis-Bacon and Copeland Anti-Kickback Acts

The CONTRACTOR agrees to comply and assure compliance of each third party contractor and each subcontractor at any tier of the project with the following Federal laws and regulations providing protections for their employees:

a. **Minimum wages** - (i) All laborers and mechanics employed or working upon the site of the work (or under the United States Housing Act of 1937 or under the Housing Act of 1949 in the construction or development of the project), will be paid unconditionally and not less often than once a week, and without subsequent deduction or rebate on any account (except such payroll deductions as are permitted by regulations issued by the Secretary of Labor under the Copeland Act (29 C.F.R. part 3)), the full amount of wages and bona fide fringe benefits (or cash equivalents thereof) due at time of payment computed at rates not less than those contained in the wage determination of the Secretary of Labor which is attached hereto and made a part hereof, regardless of any contractual relationship which may be alleged to exist between the contractor and such laborers and mechanics.

Contributions made or costs reasonably anticipated for bona fide fringe benefits under section 1(b)(2) of the Davis-Bacon Act on behalf of laborers or mechanics are considered wages paid to such laborers or mechanics, subject to the provisions of paragraph (1)(iv) of this section; also, regular contributions made or costs incurred for more than a weekly period (but not less often than quarterly) under plans, funds, or programs which cover the particular weekly period, are deemed to be constructively made or incurred during such weekly period. Such laborers and mechanics shall be paid the appropriate wage rate and fringe benefits on the wage determination for the classification of work actually performed, without regard to skill, except as provided in 29 C.F.R. Part 5.5(a)(4). Laborers or mechanics performing work in more than one classification may be compensated at the rate specified for each classification for the time actually worked therein: Provided, that the employer's payroll records accurately set forth the time spent in each classification in which work is performed. The wage determination (including any additional classifications and wage rates conformed under paragraph (1)(ii) of this section) and the Davis-Bacon poster (WH-1321) shall be posted at all times by the contractor and its subcontractors at the site of the work in a prominent and accessible place where it can be easily seen by the workers.

(ii)(A) The contracting officer shall require that any class of laborers or mechanics, including helpers, which is not listed in the wage determination, and which is to be employed under the contract shall be classified in conformance with the wage determination. The contracting officer shall approve an additional classification and wage rate and fringe benefits therefore only when the following criteria have been met:

- (1) Except with respect to helpers as defined as 29 C.F.R. 5.2(n)(4), the work to be performed by the classification requested is not performed by a classification in the wage determination; and
- (2) The classification is utilized in the area by the construction industry; and
- (3) The proposed wage rate, including any bona fide fringe benefits, bears a reasonable relationship to the wage rates contained in the wage determination; and

REQUEST FOR QUOTATION
ADA Compliant Lowered Floor Mini-Van

(4) With respect to helpers as defined in 29 C.F.R. 5.2(n)(4), such a classification prevails in the area in which the work is performed.

(B) If the contractor and the laborers and mechanics to be employed in the classification (if known), or their representatives, and the contracting officer agree on the classification and wage rate (including the amount designated for fringe benefits where appropriate), a report of the action taken shall be sent by the contracting officer to the Administrator of the Wage and Hour Division, Employment Standards Administration, U.S. Department of Labor, Washington, DC 20210. The Administrator, or an authorized representative, will approve, modify, or disapprove every additional classification action within 30 days of receipt and so advise the contracting officer or will notify the contracting officer within the 30-day period that additional time is necessary.

(C) In the event the contractor, the laborers or mechanics to be employed in the classification or their representatives, and the contracting officer do not agree on the proposed classification and wage rate (including the amount designated for fringe benefits, where appropriate), the contracting officer shall refer the questions, including the views of all interested parties and the recommendation of the contracting officer, to the Administrator for determination. The Administrator, or an authorized representative, will issue a determination within 30 days of receipt and so advise the contracting officer or will notify the contracting officer within the 30-day period that additional time is necessary.

(D) The wage rate (including fringe benefits where appropriate) determined pursuant to paragraphs (a)(1)(ii) (B) or (C) of this section, shall be paid to all workers performing work in the classification under this contract from the first day on which work is performed in the classification.

(iii) Whenever the minimum wage rate prescribed in the contract for a class of laborers or mechanics includes a fringe benefit which is not expressed as an hourly rate, the contractor shall either pay the benefit as stated in the wage determination or shall pay another bona fide fringe benefit or an hourly cash equivalent thereof.

(iv) If the contractor does not make payments to a trustee or other third person, the contractor may consider as part of the wages of any laborer or mechanic the amount of any costs reasonably anticipated in providing bona fide fringe benefits under a plan or program, provided, that the Secretary of Labor has found, upon the written request of the contractor, that the applicable standards of the Davis-Bacon Act have been met. The Secretary of Labor may require the contractor to set aside in a separate account asset for the meeting of obligations under the plan or program.

(v)(A) The contracting officer shall require that any class of laborers or mechanics which is not listed in the wage determination, and which is to be employed under the contract shall be classified in conformance with the wage determination. The contracting officer shall approve an additional classification and wage rate and fringe benefits therefore only when the following criteria have been met:

- (1) The work to be performed by the classification requested is not performed by a classification in the wage determination; and
- (2) The classification is utilized in the area by the construction industry; and
- (3) The proposed wage rate, including any bona fide fringe benefits, bears a reasonable relationship to the wage rates contained in the wage determination.

(B) If the contractor and the laborers and mechanics to be employed in the classification (if known), or their representatives, and the contracting officer agree on the classification and wage rate (including the amount designated for fringe benefits where appropriate), a report of the action taken shall be sent by the

REQUEST FOR QUOTATION
ADA Compliant Lowered Floor Mini-Van

contracting officer to the Administrator of the Wage and Hour Division, Employment Standards Administration, Washington, DC 20210. The Administrator, or an authorized representative, will approve, modify, or disapprove every additional classification action within 30 days of receipt and so advise the contracting officer or will notify the contracting officer within the 30-day period that additional time is necessary.

(C) In the event the contractor, the laborers or mechanics to be employed in the classification or their representatives, and the contracting officer do not agree on the proposed classification and wage rate (including the amount designated for fringe benefits, where appropriate), the contracting officer shall refer the questions, including the views of all interested parties and the recommendation of the contracting officer, to the Administrator for determination. The Administrator, or an authorized representative, will issue a determination with 30 days of receipt and so advise the contracting officer or will notify the contracting officer within the 30-day period that additional time is necessary.

(D) The wage rate (including fringe benefits where appropriate) determined pursuant to paragraphs (a)(1)(v) (B) or (C) of this section, shall be paid to all workers performing work in the classification under this contract from the first day on which work is performed in the classification.

b. **Withholding** - MOVTA shall upon its own action or upon written request of an authorized representative of the Department of Labor withhold or cause to be withheld from the contractor under this contract or any other Federal contract with the same prime contractor, or any other federally-assisted contract subject to Davis-Bacon prevailing wage requirements, which is held by the same prime contractor, so much of the accrued payments or advances as may be considered necessary to pay laborers and mechanics, including apprentices, trainees, and helpers, employed by the contractor or any subcontractor the full amount of wages required by the contract. In the event of failure to pay any laborer or mechanic, including any apprentice, trainee, or helper, employed or working on the site of the work (or under the United States Housing Act of 1937 or under the Housing Act of 1949 in the construction or development of the project), all or part of the wages required by the contract, MOVTA may, after written notice to the contractor, sponsor, applicant, or owner, take such action as may be necessary to cause the suspension of any further payment, advance, or guarantee of funds until such violations have ceased.

c. **Payrolls and basic records** - (i) Payrolls and basic records relating thereto shall be maintained by the contractor during the course of the work and preserved for a period of three years thereafter for all laborers and mechanics working at the site of the work (or under the United States Housing Act of 1937, or under the Housing Act of 1949, in the construction or development of the project). Such records shall contain the name, address, and social security number of each such worker, his or her correct classification, hourly rates of wages paid (including rates of contributions or costs anticipated for bona fide fringe benefits or cash equivalents thereof of the types described in section 1(b)(2)(B) of the Davis-Bacon Act, daily and weekly number of hours worked, deductions made and actual wages paid. Whenever the Secretary of Labor has found under 29 C.F.R. 5.5(a)(1)(iv) that the wages of any laborer or mechanic include the amount of any costs reasonably anticipated in providing benefits under a plan or program described in section 1(b)(2)(B) of the Davis-Bacon Act, the contractor shall maintain records which show that the commitment to provide such benefits is enforceable, that the plan or program is financially responsible, and that the plan or program has been communicated in writing to the laborers or

REQUEST FOR QUOTATION
ADA Compliant Lowered Floor Mini-Van

mechanics affected, and records which show the costs anticipated or the actual cost incurred in providing such benefits. Contractors employing apprentices or trainees under approved programs shall maintain written evidence of the registration of apprenticeship programs and certification of trainee programs, the registration of the apprentices and trainees, and the ratios and wage rates prescribed in the applicable programs.

(ii)(A) The contractor shall submit weekly for each week in which any contract work is performed a copy of all payrolls to MOVTA for transmission to the Federal Transit Administration. The payrolls submitted shall set out accurately and completely all of the information required to be maintained under section 5.5(a)(3)(i) of Regulations, 29 C.F.R. part 5. This information may be submitted in any form desired. Optional Form WH-347 is available for this purpose and may be purchased from the Superintendent of Documents (Federal Stock Number 029-005-00014-1), U.S. Government Printing Office, Washington, DC 20402. The prime contractor is responsible for the submission of copies of payrolls by all subcontractors.

(B) Each payroll submitted shall be accompanied by a "Statement of Compliance," signed by the contractor or subcontractor or his or her agent who pays or supervises the payment of the persons employed under the contract and shall certify the following:

- (1) That the payroll for the payroll period contains the information required to be maintained under section 5.5(a)(3)(i) of Regulations, 29 C.F.R. part 5 and that such information is correct and complete;
- (2) That each laborer or mechanic (including each helper, apprentice, and trainee) employed on the contract during the payroll period has been paid the full weekly wages earned, without rebate, either directly or indirectly, and that no deductions have been made either directly or indirectly from the full wages earned, other than permissible deductions as set forth in Regulations, 29 C.F.R. Part 3;
- (3) That each laborer or mechanic has been paid no less than the applicable wage rates and fringe benefits or cash equivalents for the classification of work performed, as specified in the applicable wage determination incorporated into the contract.

(C) The weekly submission of a properly executed certification set forth on the reverse side of Optional Form WH-347 shall satisfy the requirement for submission of the "Statement of Compliance" required by paragraph (a)(3)(ii)(B) of this section.

(D) The falsification of any of the above certifications may subject the contractor or subcontractor to civil or criminal prosecution under section 1001 of title 18 and section 231 of Title 31 of the United States Code.

(iii) The contractor or subcontractor shall make the records required under paragraph (a)(3)(i) of this section available for inspection, copying, or transcription by authorized representatives of the Federal Transit Administration or the Department of Labor, and shall permit such representatives to interview employees during working hours on the job. If the contractor or subcontractor fails to submit the required records or to make them available, the Federal agency may, after written notice to the contractor, sponsor, applicant, or owner, take such action as may be necessary to cause the suspension of any further payment, advance, or guarantee of funds. Furthermore, failure to submit the required records upon request or to make such records available may be grounds for debarment action pursuant to 29 C.F.R. 5.12.

d. **Apprentices and trainees** - (i) Apprentices - Apprentices will be permitted to work at less than the predetermined rate for the work they performed when they are employed pursuant to and individually

REQUEST FOR QUOTATION
ADA Compliant Lowered Floor Mini-Van

registered in a bona fide apprenticeship program registered with the U.S. Department of Labor, Employment and Training Administration, Bureau of Apprenticeship and Training, or with a State Apprenticeship Agency recognized by the Bureau, or if a person is employed in his or her first 90 days of probationary employment as an apprentice in such an apprenticeship program, who is not individually registered in the program, but who has been certified by the Bureau of Apprenticeship and Training or a State Apprenticeship Agency (where appropriate) to be eligible for probationary employment as an apprentice. The allowable ratio of apprentices to journeymen on the job site in any craft classification shall not be greater than the ratio permitted to the contractor as to the entire work force under the registered program. Any worker listed on a payroll at an apprentice wage rate, who is not registered or otherwise employed as stated above, shall be paid not less than the applicable wage rate on the wage determination for the classification of work performed. In addition, any apprentice performing work on the job site in excess of the ratio permitted under the registered program shall be paid not less than the applicable wage rate on the wage determination for the work actually performed. Where a contractor is performing construction on a project in a locality other than that in which its program is registered, the ratios and wage rates (expressed in percentages of the journeyman's hourly rate) specified in the contractor's or subcontractor's registered program shall be observed. Every apprentice must be paid at not less than the rate specified in the registered program for the apprentice's level of progress, expressed as a percentage of the journeymen hourly rate specified in the applicable wage determination. Apprentices shall be paid fringe benefits in accordance with the provisions of the apprenticeship program. If the apprenticeship program does not specify fringe benefits, apprentices must be paid the full amount of fringe benefits listed on the wage determination for the applicable classification. If the Administrator of the Wage and Hour Division of the U.S. Department of Labor determines that a different practice prevails for the applicable apprentice classification, fringes shall be paid in accordance with that determination. In the event the Bureau of Apprenticeship and Training, or a State Apprenticeship Agency recognized by the Bureau, withdraws approval of an apprenticeship program, the contractor will no longer be permitted to utilize apprentices at less than the applicable predetermined rate for the work performed until an acceptable program is approved.

(ii) Trainees - Except as provided in 29 C.F.R. 5.16, trainees will not be permitted to work at less than the predetermined rate for the work performed unless they are employed pursuant to and individually registered in a program which has received prior approval, evidenced by formal certification by the U.S. Department of Labor, Employment and Training Administration. The ratio of trainees to journeymen on the job site shall not be greater than permitted under the plan approved by the Employment and Training Administration. Every trainee must be paid at not less than the rate specified in the approved program for the trainee's level of progress, expressed as a percentage of the journeyman's hourly rate specified in the applicable wage determination. Trainees shall be paid fringe benefits in accordance with the provisions of the trainee program. If the trainee program does not mention fringe benefits, trainees shall be paid the full amount of fringe benefits listed on the wage determination unless the Administrator of the Wage and Hour Division determines that there is an apprenticeship program associated with the corresponding journeyman wage rate on the wage determination which provides for less than full fringe benefits for apprentices. Any employee listed on the payroll at a trainee rate that is not registered and participating in a training plan approved by the Employment and Training Administration shall be paid not less than the applicable wage rate on the wage determination for the classification of work actually performed. In

REQUEST FOR QUOTATION
ADA Compliant Lowered Floor Mini-Van

addition, any trainee performing work on the job site in excess of the ratio permitted under the registered program shall be paid not less than the applicable wage rate on the wage determination for the work actually performed. In the event the Employment and Training Administration withdraws approval of a training program, the contractor will no longer be permitted to utilize trainees at less than the applicable predetermined rate for the work performed until an acceptable program is approved.

(iii) Equal employment opportunity - The utilization of apprentices, trainees and journeymen under this part shall be in conformity with the equal employment opportunity requirements of Executive Order 11246, as amended, and 29 C.F.R. Part 30.

e. **Compliance with Copeland Act requirements** - The contractor shall comply with the requirements of 29 C.F.R. Part 3, which are incorporated by reference in this contract.

f. **Subcontracts** - The contractor or subcontractor shall insert in any subcontracts the clauses contained in 29 C.F.R. 5.5(a)(1) through (10) and such other clauses as the Federal Transit Administration may by appropriate instructions require, and also a clause requiring the subcontractors to include these clauses in any lower tier subcontracts. The prime contractor shall be responsible for the compliance by any subcontractor or lower tier subcontractor with all the contract clauses in 29 C.F.R. 5.5.

g. **Contract termination: debarment** - A breach of the contract clauses in 29 C.F.R. 5.5 may be grounds for termination of the contract, and for debarment as a contractor and a subcontractor as provided in 29 C.F.R. 5.12.

h. **Compliance with Davis-Bacon and Related Act requirements** - All rulings and interpretations of the Davis-Bacon and Related Acts contained in 29 C.F.R. parts 1, 3, and 5 are herein incorporated by reference in this contract.

i. **Disputes concerning labor standards** - Disputes arising out of the labor standards provisions of this contract shall not be subject to the general disputes clause of this contract. Such disputes shall be resolved in accordance with the procedures of the Department of Labor set forth in 29 C.F.R. Parts 5, 6, and 7.

Disputes within the meaning of this clause include disputes between the contractor (or any of its subcontractors) and the contracting agency, the U.S. Department of Labor, or the employees or their representatives.

j. **Certification of eligibility** - (i) By entering into this contract, the contractor certifies that neither it (nor he or she) nor any person or firm who has an interest in the contractor's firm is a person or firm ineligible to be awarded Government contracts by virtue of section 3(a) of the Davis-Bacon Act or 29 C.F.R. 5.12(a)(1).

(ii) No part of this contract shall be subcontracted to any person or firm ineligible for award of a Government contract by virtue of section 3(a) of the Davis-Bacon Act or 29 C.F.R. 5.12(a)(1).

(iii) The penalty for making false statements is prescribed in the U.S. Criminal Code, 18 U.S.C. 1001.

19. Contract Work Hours and Safety Standards Act

The CONTRACTOR agrees to comply with and assure compliance by subcontractors and other project participants for construction employees with the Contract Work Hours and Safety Standards Act, as amended, 40 U.S.C. §§ 3701 et seq., specifically the wage and hour requirements of section 102 of that Act at 40 U.S.C. § 3702, and implementing U.S. DOL regulations, "Labor Standards Provisions Applicable to Contracts Governing Federally Financed and Assisted Construction (also Labor Standards Provisions Applicable to Nonconstruction Contracts Subject to the Contract Work Hours and Safety Standards Act)," 29 C.F.R. Part 5; and the safety requirements of section 107 of that Act at 40 U.S.C. §

REQUEST FOR QUOTATION
ADA Compliant Lowered Floor Mini-Van

3704, and implementing U.S. DOL regulations, "Safety and Health Regulations for Construction," 29 C.F.R. Part 1926.

The CONTRACTOR further agrees to comply with and assure compliance by other project participants for nonconstruction employees with the Contract Work Hours and Safety Standards Act, as amended, 40 U.S.C. §§ 3701 et seq., in particular with the wage and hour requirements of section 102 of that Act at 40 U.S.C. § 3702, and with implementing U.S. DOL regulations, "Labor Standards Provisions Applicable to Contracts Governing Federally Financed and Assisted Construction (also Labor Standards Provisions Applicable to Nonconstruction Contracts Subject to the Contract Work Hours and safety Standards Act)," 29 C.F.R. Part 5.

20. Bonding Requirements

Bid Bond Requirements

Bid Bond will be five (5) percent of the bid price and must be issued by a fully qualified surety company acceptable to MOVTA and listed as a company currently authorized under 31 C.F.R., Part 223 as possessing a Certificate of Authority as described thereunder.

In submitting this Bid, it is understood and agreed by bidder that the right is reserved by MOVTA to reject any and all bids, or part of any bid, and it is agreed that the Bid may not be withdrawn for a period of [ninety (90)] days subsequent to the opening of bids, without the written consent of MOVTA.

It is also understood and agreed that if the undersigned bidder should withdraw any part or all of his bid within [ninety (90)] days after the bid opening without the written consent of MOVTA, shall refuse or be unable to enter into this Contract, as provided above, or refuse or be unable to furnish adequate and acceptable Performance Bonds and Labor and Material Payments Bonds, or refuse or be unable to furnish adequate and acceptable insurance, he shall forfeit his bid security to the extent of MOVTA damages occasioned by such withdrawal, or refusal, or inability to enter into an agreement, or provide adequate security therefor.

It is further understood and agreed that to the extent the defaulting bidder's Bid Bond, Certified Check, Cashier's Check, Treasurer's Check, and/or Official Bank Check (excluding any income generated thereby which has been retained by MOVTA as provided in [Item x "Bid Security" of the Instructions to Bidders]) shall prove inadequate to fully recompense MOVTA for the damages occasioned by default, then the undersigned bidder agrees to indemnify MOVTA and pay over to MOVTA the difference between the bid security and MOVTA's total damages, so as to make MOVTA whole. The undersigned understands that any material alteration of any of the above or any of the material contained on this form, other than that requested, will render the bid unresponsive.

Performance Bonds

1. The penal amount of performance bonds shall be 100 percent of the original contract price, unless MOVTA determines that a lesser amount would be adequate for the protection of MOVTA.
2. MOVTA may require additional performance bond protection when a contract price is increased. The increase in protection shall generally equal 100 percent of the increase in contract price. MOVTA may secure additional protection by directing the Contractor to increase the penal amount of the existing bond or to obtain an additional bond.

REQUEST FOR QUOTATION
ADA Compliant Lowered Floor Mini-Van

Payment Bonds

A payment bond of 100 percent of the original contract price unless MOVTA determines that a lesser amount would be adequate for the protection of MOVTA.

21. Veterans Preference

As provided in 49 U.S.C. § 5325(k), to the extent practicable, the contractor agrees and assures that it and its subcontractors will give a hiring preference to veterans, as defined in 5 U.S.C. § 2108, who have the skills and abilities required to perform construction work required under the contract.

This does not require the contractor to give a preference to any veteran over any equally qualified applicant who is a member of any racial or ethnic minority, female, an individual with a disability, or a former employee.

22. Seismic Safety

The CONTRACTOR agrees that they will comply with 42 U.S.C. §7701 et seq. in accordance with Executive Order No. 12699 as well as with the standards for Seismic Safety required in Department of Transportation Seismic Safety Regulations 49 C.F.R. Part 41 and will certify to compliance to the extent required by the regulation. The CONTRACTOR also agrees to ensure that all work performed under this contract including work performed by a subcontractor is in compliance with the standards required by the Seismic Safety Regulations and the certification of compliance issued on the project.

23. Recycled Products

To the extent applicable, the CONTRACTOR agrees to comply with U.S. EPA regulations, "Comprehensive Procurement Guidelines for Products Containing Recovered Materials," 40 C.F.R. Part 247, implementing section 6002 of the Resource Conservation and Recovery Act, as amended, 42 U.S.C. § 6962, and otherwise provide a competitive preference for products and services that conserve natural resources and protect the environment and are energy efficient.

24. Accessibility

The CONTRACTOR agrees to comply with 49 U.S.C. §5301(d), which states the Federal policy that elderly individuals and individuals with disabilities have the same right as other individuals to use public transportation services and facilities, and that special efforts shall be made in planning and designing those services and facilities to implement transportation accessibility rights for elderly individuals and individuals with disabilities. The CONTRACTOR also agrees to comply with all applicable provisions of Section 504 of the Rehabilitation Act, as amended, 29 U.S.C. §794, which prohibits discrimination on the basis of disability in the administration of programs or activities receiving Federal financial assistance; with the Americans with Disabilities Act of 1990 (ADA), as amended, 42 U.S.C. §12101 et seq., which requires that accessible facilities and services be made available to individuals with disabilities; with the Architectural Barriers Act of 1968, a amended, 42 U.S.C. §4151 et seq., which requires that buildings and public accommodations be accessible to individuals with disabilities; and with other laws and amendments thereto pertaining to access for individuals with disabilities that may be applicable. In

REQUEST FOR QUOTATION
ADA Compliant Lowered Floor Mini-Van

addition, the CONTRACTOR agrees to comply with applicable implementing Federal regulations and any later amendments thereto, and agrees to follow applicable Federal implementing directives, except to the extent the FTA approves otherwise in writing.

25. Equal Employment Opportunity

During the performance of this contract, the contractor agrees as follows:

(1) The contractor will not discriminate against any employee or applicant for employment because of race, color, religion, sex, sexual orientation, gender identity, or national origin. The contractor will take affirmative action to ensure that applicants are employed, and that employees are treated during employment without regard to their race, color, religion, sex, sexual orientation, gender identity, or national origin. Such action shall include, but not be limited to the following:

Employment, upgrading, demotion, or transfer; recruitment or recruitment advertising; layoff or termination; rates of pay or other forms of compensation; and selection for training, including apprenticeship. The contractor agrees to post in conspicuous places, available to employees and applicants for employment, notices to be provided setting forth the provisions of this nondiscrimination clause.

(2) The contractor will, in all solicitations or advertisements for employees placed by or on behalf of the contractor, state that all qualified applicants will receive consideration for employment without regard to race, color, religion, sex, sexual orientation, gender identity, or national origin.

(3) The contractor will not discharge or in any other manner discriminate against any employee or applicant for employment because such employee or applicant has inquired about, discussed, or disclosed the compensation of the employee or applicant or another employee or applicant. This provision shall not apply to instances in which an employee who has access to the compensation information of other employees or applicants as a part of such employee's essential job functions discloses the compensation of such other employees or applicants to individuals who do not otherwise have access to such information, unless such disclosure is in response to a formal complaint or charge, in furtherance of an investigation, proceeding, hearing, or action, including an investigation conducted by the employer, or is consistent with the contractor's legal duty to furnish information.

(4) The contractor will send to each labor union or representative of workers with which he has a collective bargaining agreement or other contract or understanding, a notice to be provided advising the said labor union or workers' representatives of the contractor's commitments under this section, and shall post copies of the notice in conspicuous places available to employees and applicants for employment.

(5) The contractor will comply with all provisions of Executive Order 11246 of September 24, 1965, and of the rules, regulations, and relevant orders of the Secretary of Labor.

(6) The contractor will furnish all information and reports required by Executive Order 11246 of September 24, 1965, and by rules, regulations, and orders of the Secretary of Labor, or pursuant thereto, and will permit access to his books, records, and accounts by the administering agency and the Secretary of Labor for purposes of investigation to ascertain compliance with such rules, regulations, and orders.

(7) In the event of the contractor's noncompliance with the nondiscrimination clauses of this contract or with any of the said rules, regulations, or orders, this contract may be canceled, terminated, or suspended in whole or in part and the contractor may be declared ineligible for further Government contracts or federally assisted construction contracts in accordance with procedures authorized in Executive Order

REQUEST FOR QUOTATION
ADA Compliant Lowered Floor Mini-Van

11246 of September 24, 1965, and such other sanctions may be imposed and remedies invoked as provided in Executive Order 11246 of September 24, 1965, or by rule, regulation, or order of the Secretary of Labor, or as otherwise provided by law.

(8) The contractor will include the portion of the sentence immediately preceding paragraph (1) and the provisions of paragraphs (1) through (8) in every subcontract or purchase order unless exempted by rules, regulations, or orders of the Secretary of Labor issued pursuant to section 204 of Executive Order 11246 of September 24, 1965, so that such provisions will be binding upon each subcontractor or vendor. The contractor will take such action with respect to any subcontract or purchase order as the administering agency may direct as a means of enforcing such provisions, including sanctions for noncompliance: Provided, however, that in the event a contractor becomes involved in, or is threatened with, litigation with a subcontractor or vendor as a result of such direction by the administering agency, the contractor may request the United States to enter into such litigation to protect the interests of the United States. The applicant further agrees that it will be bound by the above equal opportunity clause with respect to its own employment practices when it participates in federally assisted construction work: Provided, That if the applicant so participating is a State or local government, the above equal opportunity clause is not applicable to any agency, instrumentality or subdivision of such government which does not participate in work on or under the contract.

The applicant agrees that it will assist and cooperate actively with the administering agency and the Secretary of Labor in obtaining the compliance of contractors and subcontractors with the equal opportunity clause and the rules, regulations, and relevant orders of the Secretary of Labor, that it will furnish the administering agency and the Secretary of Labor such information as they may require for the supervision of such compliance, and that it will otherwise assist the administering agency in the discharge of the agency's primary responsibility for securing compliance.

The applicant further agrees that it will refrain from entering into any contract or contract modification subject to Executive Order 11246 of September 24, 1965, with a contractor debarred from, or who has not demonstrated eligibility for, Government contracts and federally assisted construction contracts pursuant to the Executive Order and will carry out such sanctions and penalties for violation of the equal opportunity clause as may be imposed upon contractors and subcontractors by the administering agency or the Secretary of Labor pursuant to Part II, Subpart D of the Executive Order. In addition, the applicant agrees that if it fails or refuses to comply with these undertakings, the administering agency may take any or all of the following actions: Cancel, terminate, or suspend in whole or in part this grant (contract, loan, insurance, guarantee); refrain from extending any further assistance to the applicant under the program with respect to which the failure or refund occurred until satisfactory assurance of future compliance has been received from such applicant; and refer the case to the Department of Justice for appropriate legal proceedings.

Each nonexempt prime contractor or subcontractor shall include the equal opportunity clause in each of its nonexempt subcontracts.

26. Seat Belt Use

The Contractor agrees to adopt and promote on-the-job seat belt use policies and programs for its employees and other personnel that operate company-owned vehicles, company-rented vehicles, or personally operated vehicles.

REQUEST FOR QUOTATION
ADA Compliant Lowered Floor Mini-Van

27. Distracted Driving

The Contractor agrees to adopt and enforce workplace safety policies to decrease crashes caused by distracted drivers, including policies to ban text messaging while using an electronic device supplied by an employer, and driving a vehicle the driver owns or rents, a vehicle Recipient owns, leases, or rents, or a privately-owned vehicle when on official business in connection with the Award, or when performing any work for or on behalf of the project.

The Contractor agrees to conduct workplace safety initiatives in a manner commensurate with its size, such as establishing new rules and programs to prohibit text messaging while driving, re-evaluating the existing programs to prohibit text messaging while driving, and providing education, awareness, and other outreach to employees about the safety risks associated with texting while driving.

The Contractor agrees to include the preceding Special Provision in its subcontractor agreements.



Department of Administration
 Purchasing Division
 2019 Washington Street East
 Post Office Box 50130
 Charleston, WV 25305-0130

State of West Virginia
 Centralized Request for Quote
 Vehicles

Proc Folder: 1387185		Reason for Modification: ADDENDUM NO_3 Vendor Questions and responses	
Doc Description: ADA Compliant Lowered Floor Minivans			
Proc Type: Central Master Agreement			
Date Issued	Solicitation Closes	Solicitation No	Version
2024-05-13	2024-05-30 13:30	CRFQ 0810 DMT2400000006	4

BID RECEIVING LOCATION

BID CLERK
 DEPARTMENT OF ADMINISTRATION
 PURCHASING DIVISION
 2019 WASHINGTON ST E
 CHARLESTON WV 25305
 US

VENDOR

Vendor Customer Code: VS0000004719
Vendor Name : Rohrer Enterprises, Inc. DBA Rohrer Bus Sales
Address : 1515 State Road PO Box 100
Street :
City : Duncannon
State : PA **Country :** USA **Zip :** 17020
Principal Contact : David M Clawson, Senior Vice President Sales
Vendor Contact Phone: 540-729-3751 **Extension:**

FOR INFORMATION CONTACT THE BUYER
 John W Estep
 304-558-2566
 john.w.estep@wv.gov

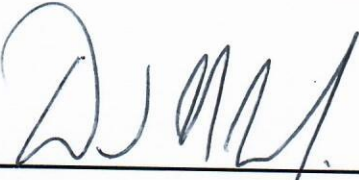
Vendor Signature X  **FEIN#** 23-205997 **DATE** 5/29/24

All offers subject to all terms and conditions contained in this solicitation

ADDITIONAL INFORMATION

ADDENDUM NO_3

Addendum No_3 issued to publish and distribute the attached information to the Vendor Community

REQUEST FOR QUOTATION:

The West Virginia Purchasing Division is soliciting bids on behalf of the Division of Multimodal Transportation Facilities -Public Transit (DMTF-PT); and any other agency that desires to utilize this contract, to establish an open-ended contract for Americans with Disabilities Act (ADA) Compliant Lowered Floor Min-Van(s). The offered vehicles would include wheelchair securements and a deployable ramp to provide transportation services in an urban/rural environment which includes mountainous terrain and a severe weather operating climate. The offered vehicle shall be capable to perform stop-start duty cycles. Per the Bid Requirements, Specifications, Terms and Conditions attached to this solicitation.

INVOICE TO	SHIP TO
------------	---------

PUBLIC TRANSIT DIVISION OF BLDG 5 RM 663 1900 KANAWHA BLVD E CHARLESTON WV US	PUBLIC TRANSIT DIVISION OF KANAWHA VALLEY REGIONAL TRANSPORTATION AUTHORITY 1550 FOURTH AVE CHARLESTON WV US
--	--

Line	Comm Ln Desc	Qty	Unit Issue	Unit Price	Total Price
1	ADA Lowered Floor Minivans	10.00000	EA		

Comm Code	Manufacturer	Specification	Model #
25101502			

Extended Description:
 To establish an open-ended contract for ADA Lowered Floor Minivans. These vehicles will not possess any graphics.

SCHEDULE OF EVENTS

Line	Event	Event Date
1	Tech Questions dur by 10:00am	2024-04-26

SOLICITATION NUMBER: CRFQ DMT2400000006

Addendum Number: 3

The purpose of this addendum is to modify the solicitation identified as CRFQ DMT2400000006 ("Solicitation") to reflect the change(s) identified and described below.

Applicable Addendum Category:

- Modify bid opening date and time
- Modify specifications of product or service being sought
- Attachment of vendor questions and responses
- Attachment of pre-bid sign-in sheet
- Correction of error
- Other

Additional Documentation:

Bid Opening remains 05/30/2024 at 1:30pm

Terms and Conditions:

1. All provisions of the Solicitation and other addenda not modified herein shall remain in full force and effect.
2. Vendor should acknowledge receipt of all addenda issued for this Solicitation by completing an Addendum Acknowledgment, a copy of which is included herewith. Failure to acknowledge addenda may result in bid disqualification. The addendum acknowledgement should be submitted with the bid to expedite document processing.

ADDENDUM ACKNOWLEDGEMENT FORM
SOLICITATION NO.: CRFO DMT240000006

Instructions: Please acknowledge receipt of all addenda issued with this solicitation by completing this addendum acknowledgment form. Check the box next to each addendum received and sign below. Failure to acknowledge addenda may result in bid disqualification.

Acknowledgment: I hereby acknowledge receipt of the following addenda and have made the necessary revisions to my proposal, plans and/or specification, etc.

Addendum Numbers Received:

(Check the box next to each addendum received)

- | | |
|--|--|
| <input type="checkbox"/> Addendum No. 1 | <input type="checkbox"/> Addendum No. 6 |
| <input type="checkbox"/> Addendum No. 2 | <input type="checkbox"/> Addendum No. 7 |
| <input checked="" type="checkbox"/> Addendum No. 3 | <input type="checkbox"/> Addendum No. 8 |
| <input type="checkbox"/> Addendum No. 4 | <input type="checkbox"/> Addendum No. 9 |
| <input type="checkbox"/> Addendum No. 5 | <input type="checkbox"/> Addendum No. 10 |

I understand that failure to confirm the receipt of addenda may be cause for rejection of this bid. I further understand that that any verbal representation made or assumed to be made during any oral discussion held between Vendor's representatives and any state personnel is not binding. Only the information issued in writing and added to the specifications by an official addendum is binding.

Rohrer Enterprises, Inc. DBA Rohrer Bus Sales

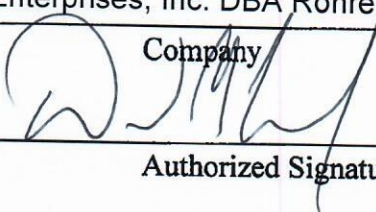
Company

Authorized Signature
5/29/24

Date

NOTE: This addendum acknowledgment should be submitted with the bid to expedite document processing.

4 3.1.1.9 Water Test The Braun Corporation seeks approval of our current testing method in lieu of the method called by specification. Our water test method combines two methods of detecting leaks: Ultrasonic Sound Testing and high-pressure wash bay rinse. Ultrasonic Testing procedure is attached. The high-pressure rinse cycle shall be utilized to completely drench each vehicle with water from top, front, back, both sides and the under-frame area. Each vehicle shall be exposed to this high-pressure water spray for a continuous period of fifteen minutes. Spray nozzles shall be arranged to ensure water spray on the roof, all doors, all windows, rear wall, windshield, and in the wheel well areas under the frame. If any leaks are discovered, they will be addressed and then the vehicle will be retested.-**That is acceptable.**

9 3.14.7 BODY STRUCTURE The Voyager LX proposed will be equipped with OEM power side slide doors, in lieu of manual side slide doors as currently called out in the specification.

13 3.18.8 EXTERIOR LIGHTING Please note that The Braun Corporation conversion utilizes an interior mounted light to illuminate the area immediately around the passenger side slide door to achieve lighting compliance as required by ADA. No exterior hooded light is included.-**That is acceptable.**

20 3.29.1 WHEELCHAIR RAMP The Braun Corporation recommends that specification be amended to require that the ramp include a swing-out feature. This feature is a crucial item to facilitate ambulatory passenger entry/exit without the need to manually deploy the ramp. We suggest the following verbiage be incorporated to the existing specification: The vehicle shall be equipped with a manually operated, 80-degree (nominal) swing-away mobility access ramp which stows vertically and folds and unfolds through the passenger side slide door. The ramp swings out to provide unobstructed ambulatory passenger entry/exit.-**We accept this recommendation.**

21 3.31.5 MISC. ADDITIONS The Braun Corporation requests approved equal status for the following described Angel Trax camera package in lieu of the 6-camera package currently called by specification. The following camera package is better suited to the lowered floor minivan application: Two (2) camera video recording system. Cameras mounted to record audio and video of 1) driver area and passenger area looking from front to back; and 2) Front view camera shall be mounted facing forward out the front window. Vulcan Series 5 Channel HD/IP Mobile Digital Video Recorder, 512 GB SD Solid state Memory Card, Vulcan Series Panic Button Housing, Vulcan Series Anvil 3600 HD Low Profile Camera, Vulcan Series HDWS3600 1080P Windshield Camera, and (2) 13.12' HD Camera Cable.-**We approve.**

The Braun Corporation requests approval to offer the Infloor Simple Stow ramp as an option available for an additional cost. This item would replace the swing out ramp included in the base vehicle price. Please see attached brochure outlining the benefits of this innovative product.-**We accept this suggestion and will add the option to the list of options.**

2024 Chrysler Voyager Passenger Van LX (RUCL53)

Engine: 3.6L V6 24V VVT UPG I w/ESS

Transmission: 9-Speed 948TE Automatic

Exterior (0 P) Bright White
Clearcoat

Interior (0 I) Black/Alloy/Black

CHRYSLER

Standard Equipment

Items Featured Below are included at NO EXTRA CHARGE in the Standard Vehicle Price Shown at Right

- 3.6L V-6 DOHC w/SMPI 287hp
- 9 speed automatic trans w/OD
- 4-wheel ABS
- Brake assistance
- Traction control
- P235/65R17 BSW H-rated tires
- Battery with run down protection
- Touring suspension
- Electronic stability
- Automatic air conditioning
- AM/FM SiriusXM satellite radio
- Daytime running lights
- Rear child safety locks
- 60-40 folding 3rd row split-bench seats
- Dual power remote heated mirrors
- Variable intermittent wipers
- Silver aluminum wheels
- Dual front airbags
- Driver & front passenger seat mounted side airbags
- Airbag occupancy sensor
- Sentry Key immobilizer
- Rear window defogger
- Tachometer
- Trip computer
- Underseat ducts
- Heated reclining front bucket seats
- 2nd row bucket seat

OPTIONAL EQUIPMENT

50 State Emissions	N/C
Quick Order Package 27E	N/C
Engine: 3.6L V6 24V VVT UPG I w/ESS	STD
Transmission: 9-Speed 948TE Automatic	STD
3.25 Axle Ratio	STD
GVWR: 6,055 lbs	STD
Tires: 235/65R17 BSW AS	STD
Wheels: 17" x 7" Aluminum	STD
Cloth Bucket Seats	STD
Black Seats	N/C
Touring Suspension	STD
Radio: Uconnect 5 w/7" Display	STD
Interior : Black/Alloy/Black	N/C
Primary : Bright White Clearcoat	N/C

CITY MPG

19



HIGHWAY MPG

28

3.3.1.1

3.6.1

10.2A

2024 Chrysler Voyager LX



CHRYSLER



INDEX 2024 Chrysler Voyager

Description	Passenger Van LX (RUCL53) Page
Cover	1
Index	2
Vehicle Overview	3
Standard Equipment	6
Selected Equipment	9
Dimensions & Capacities	11
Warranty	13
Available Equipment	14
Job Rating	14
Window Sticker	16

3.3.1.1
3.6.1



VEHICLE OVERVIEW

2024 Chrysler Voyager

Passenger Van LX (RUCL53)

Powertrain

3.6L V-6 DOHC SMPI 24 valve engine with VVT variable valve control, cylinder deactivation * 180 amp alternator * 650 amp battery with run down protection, auxiliary battery * Engine oil cooler, transmission oil cooler * 9-speed electronic automatic transmission with overdrive, lock-up * Front-wheel drive * ABS & driveline traction control * 3.25 axle ratio * Stainless steel exhaust

Steering and Suspension

Electric power-assist rack and pinion steering * 4-wheel disc brakes with front vented discs * Touring ride suspension, with electronic stability * Independent front suspension * Front strut suspension * Front anti-roll bar * Front coil springs * Gas-pressurized front shocks * Rear independent suspension * Rear trailing arm suspension * Rear coil springs * Gas-pressurized rear shocks * Front and rear 17.0" x 7.00" silver aluminum wheels * P235/65HR17.0 BSW AS front and rear tires

Safety

4-wheel anti-lock braking system * Daytime running lights, center high mounted stop light * Dual airbags, seat mounted driver and passenger side-impact airbags, curtain 1st, 2nd and 3rd row overhead airbag, airbag occupancy sensor, driver and passenger knee airbag * Front and rear height adjustable seatbelts with front pre-tensioners * Sentry Key immobilizer, panic alarm, security system

Comfort and Convenience

Automatic dual zone front air conditioning, rear HVAC with separate controls, air filter, underseat ducts, headliner/pillar ducts * SiriusXM AM/FM/Satellite, clock, seek-scan, Uconnect 5 external memory control, 6 speakers, speed sensitive volume, Bluetooth streaming audio, active noise cancellation, integrated roof antenna, radio steering wheel controls * 2 1st row LCD monitors * Cruise control with steering wheel controls * Power door locks with 2 stage unlock, keyfob (all doors) keyless entry, power remote cargo access release, child safety rear door locks, tailgate/rear door lock included with power door locks * 2 12V DC power outlets, trunk/hatch auto-latch, driver foot rest, retained accessory power, Bluetooth wireless phone connectivity * Analog instrumentation appearance includes tachometer, oil pressure gauge, engine/motor temperature gauge, voltmeter gauge, oil temperature gauge, transmission fluid temp gauge, compass, exterior temp, driver information center, redundant digital speedometer, camera(s) - rear camera, trip computer, trip odometer, forward collision * Warning indicators include oil pressure, engine temperature, battery, lights on, key, low fuel, low washer fluid, door ajar, rear cargo ajar, service interval, brake fluid, turn signal on, tire specific low tire pressure, transmission fluid temp * TechnoLeather leatherette steering wheel with tilt and telescopic adjustment * Power front and rear windows with deep tint, driver and passenger 1-touch down, fixed rearmost windows * Variable intermittent front windshield wipers, fixed interval rear

The information contained in this package is provided to assist in assessing our vehicles and is for your information only. Prices and content information shown are subject to change and should be treated as estimates only. Information on the comparison vehicle is derived from available public sources and may not be completely current or accurate. No representations, warranties or guarantees are given in the information. Neither Chrysler nor the dealer will be liable for any reliance on the contents hereof. Please see salesperson for the most current information and other details. Actual pricing may vary. Reference DX05103297 6/2/2023

VEHICLE OVERVIEW Continued

Comfort and Convenience (Continued)

wiper, rear window defroster * Dual illuminated vanity mirrors * Day-night rearview mirror * Interior lights include dome light with fade, front reading lights, illuminated entry * Partial floor console with storage, mini overhead console with storage, conversation mirror, locking glove box, front and rear cupholders, instrument panel bin, interior concealed storage, 2 seat back storage pockets, driver and passenger door bins, rear door bins * Carpeted cargo floor, plastic trunk lid/rear cargo door, cargo tie downs, cargo light, tire mobility kit

Seating and Interior

Seating capacity of 7 * Bucket front seats with driver and passenger heated-cushion, driver and passenger heated-seatback, adjustable head restraints with tilt, driver and passenger armrests * 8-way adjustable (8-way power) driver seat includes power 4-way lumbar support * 4-way adjustable passenger seat * Bucket 2nd row seat with fold forward seatback, reclining folding activation, 2 fixed rear head restraints, armrest mounted outboard only * 3rd row seat 60-40 folding split-bench fold into floor with reclining fold into floor, 3 fixed 3rd row head restraints * Cloth faced front seats with cloth back material * Cloth faced rear seats with plastic back material * Cloth faced 3rd row seats with carpet back material * Full cloth headliner, full carpet floor covering with carpet front and rear floor mats, colored instrument panel insert, metal-look gear shifter material, colored door panel insert, piano black console insert, piano black/metal-look interior accents

Exterior Features

Rear lip spoiler, side impact beams, front license plate bracket, galvanized steel/aluminum body material * Chrome side window moldings * Body-colored door handles * Black w/chrome surround grille * 4 doors with power sliding rear driver's side door, power sliding rear passenger's side door power liftgate rear cargo door * Driver and passenger power remote black heated folding outside mirrors * Front and rear body-colored bumpers * Aero-composite halogen auto on/off headlamps with multiple headlamps, delay-off feature * Clearcoat monotone paint

Warranty

Basic	36 month/36,000 miles	Powertrain	60 month/60,000 miles
Corrosion Perforation	60 month/unlimited mileage	Roadside Assistance	60 month/60,000 miles

Dimensions and Capacities

Output	287 hp @ 6,400 rpm	Torque	262 lb.-ft. @ 4,000 rpm
Drag coefficient	0.30	1st gear ratio	4.710
2nd gear ratio	2.840	3rd gear ratio	1.910
4th gear ratio	1.380	5th gear ratio	1.000
6th gear ratio	0.810	7th gear ratio	0.700
8th gear ratio	0.580	9th gear ratio	0.480
Reverse gear ratio	3.810	City/hwy	19 mpg/28 mpg
Curb weight	4,330 lbs.	GVWR	6,055 lbs.
Towing capacity	3,600 lbs.	Front legroom	41.1 "
Rear legroom	39.0 "	Third legroom	36.5 "
Front headroom	40.1 "	Rear headroom	39.6 "

The information contained in this package is provided to assist in assessing our vehicles and is for your information only. Prices and content information shown are subject to change and should be treated as estimates only. Information on the comparison vehicle is derived from available public sources and may not be completely current or accurate. No representations, warranties or guarantees are given in the information. Neither Chrysler nor the dealer will be liable for any reliance on the contents hereof. Please see salesperson for the most current information and other details. Actual pricing may vary. Reference DX05103297 6/2/2023

VEHICLE OVERVIEW Continued

Dimensions and Capacities (Continued)

Third headroom	38.7 "	Front hiproom	59.0 "
Rear hiproom	64.8 "	Third hiproom	49.5 "
Front shoulder room	63.8 "	Rear shoulder room	63.0 "
Third shoulder room	61.2 "	Passenger area volume	165.0 cu.ft.
Length	203.8 "	Body width	79.6 "
Body height	69.9 "	Wheelbase	121.6 "
Front track	68.3 "	Rear track	68.3 "
Turning radius	19.8 '	Fuel tank	19.0 gal.
Interior rear cargo volume	32.3 cu.ft.	Interior rear cargo volume seats folded	87.5 cu.ft.
Interior maximum rear cargo volume	140.5 cu.ft.		

The information contained in this package is provided to assist in assessing our vehicles and is for your information only. Prices and content information shown are subject to change and should be treated as estimates only. Information on the comparison vehicle is derived from available public sources and may not be completely current or accurate. No representations, warranties or guarantees are given in the information. Neither Chrysler nor the dealer will be liable for any reliance on the contents hereof. Please see salesperson for the most current information and other details. Actual pricing may vary. Reference DX05103297 6/2/2023



STANDARD EQUIPMENT

2024 Chrysler Voyager

Passenger Van LX (RUCL53)

Powertrain

3.6L V-6 DOHC SMPI 24 valve engine with VVT variable valve control, cylinder deactivation * 180 amp alternator * 650 amp battery with run down protection, auxiliary battery * Engine oil cooler, transmission oil cooler * 9-speed electronic automatic transmission with overdrive, lock-up * Front-wheel drive * ABS & driveline traction control * 3.25 axle ratio * Stainless steel exhaust

Steering and Suspension

Electric power-assist rack and pinion steering * 4-wheel disc brakes with front vented discs * Touring ride suspension, with electronic stability * Independent front suspension * Front strut suspension * Front anti-roll bar * Front coil springs * Gas-pressurized front shocks * Rear independent suspension * Rear trailing arm suspension * Rear coil springs * Gas-pressurized rear shocks * Front and rear 17.0" x 7.00" silver aluminum wheels * P235/65HR17.0 BSW AS front and rear tires

Safety

4-wheel anti-lock braking system * Daytime running lights, center high mounted stop light * Dual airbags, seat mounted driver and passenger side-impact airbags, curtain 1st, 2nd and 3rd row overhead airbag, airbag occupancy sensor, driver and passenger knee airbag * Front and rear height adjustable seatbelts with front pre-tensioners * Sentry Key immobilizer, panic alarm, security system

Comfort and Convenience

Automatic dual zone front air conditioning, rear HVAC with separate controls, air filter, underseat ducts, headliner/pillar ducts * SiriusXM AM/FM/Satellite, clock, seek-scan, Uconnect 5 external memory control, 6 speakers, speed sensitive volume, Bluetooth streaming audio, active noise cancellation, integrated roof antenna, radio steering wheel controls * 2 1st row LCD monitors * Cruise control with steering wheel controls * Power door locks with 2 stage unlock, keyfob (all doors) keyless entry, power remote cargo access release, child safety rear door locks, tailgate/rear door lock included with power door locks * 2 12V DC power outlets, trunk/hatch auto-latch, driver foot rest, retained accessory power, Bluetooth wireless phone connectivity * Analog instrumentation appearance includes tachometer, oil pressure gauge, engine/motor temperature gauge, voltmeter gauge, oil temperature gauge, transmission fluid temp gauge, compass, exterior temp, driver information center, redundant digital speedometer, camera(s) - rear camera, trip computer, trip odometer, forward collision * Warning indicators include oil pressure, engine temperature, battery, lights on, key, low fuel, low washer fluid, door ajar, rear cargo ajar, service interval, brake fluid, turn signal on, tire specific low tire pressure, transmission fluid temp * TechnoLeather leatherette steering wheel with tilt and telescopic adjustment * Power front and rear windows with deep tint, driver and passenger 1-touch down, fixed rearmost windows *

The information contained in this package is provided to assist in assessing our vehicles and is for your information only. Prices and content information shown are subject to change and should be treated as estimates only. Information on the comparison vehicle is derived from available public sources and may not be completely current or accurate. No representations, warranties or guarantees are given in the information. Neither Chrysler nor the dealer will be liable for any reliance on the contents hereof. Please see salesperson for the most current information and other details. Actual pricing may vary. Reference DX05103297 6/2/2023

* 3.6.4

STANDARD EQUIPMENT Continued

Comfort and Convenience (Continued)

Variable intermittent front windshield wipers, fixed interval rear wiper, rear window defroster * Dual illuminated vanity mirrors * Day-night rearview mirror * Interior lights include dome light with fade, front reading lights, illuminated entry * Partial floor console with storage, mini overhead console with storage, conversation mirror, locking glove box, front and rear cupholders, instrument panel bin, interior concealed storage, 2 seat back storage pockets, driver and passenger door bins, rear door bins * Carpeted cargo floor, plastic trunk lid/rear cargo door, cargo tie downs, cargo light, tire mobility kit

Seating and Interior

Seating capacity of 7 * Bucket front seats with driver and passenger heated-cushion, driver and passenger heated-seatback, adjustable head restraints with tilt, driver and passenger armrests * 8-way adjustable (8-way power) driver seat includes power 4-way lumbar support * 4-way adjustable passenger seat * Bucket 2nd row seat with fold forward seatback, reclining folding activation, 2 fixed rear head restraints, armrest mounted outboard only * 3rd row seat 60-40 folding split-bench fold into floor with reclining fold into floor, 3 fixed 3rd row head restraints * Cloth faced front seats with cloth back material * Cloth faced rear seats with plastic back material * Cloth faced 3rd row seats with carpet back material * Full cloth headliner, full carpet floor covering with carpet front and rear floor mats, colored instrument panel insert, metal-look gear shifter material, colored door panel insert, piano black console insert, piano black/metal-look interior accents

Exterior Features

Rear lip spoiler, side impact beams, front license plate bracket, galvanized steel/aluminum body material * Chrome side window moldings * Body-colored door handles * Black w/chrome surround grille * 4 doors with power sliding rear driver's side door, power sliding rear passenger's side door power liftgate rear cargo door * Driver and passenger power remote black heated folding outside mirrors * Front and rear body-colored bumpers * Aero-composite halogen auto on/off headlamps with multiple headlamps, delay-off feature * Clearcoat monotone paint

Warranty

Basic	36 month/36,000 miles	Powertrain	60 month/60,000 miles
Corrosion Perforation	60 month/unlimited mileage	Roadside Assistance	60 month/60,000 miles

Dimensions and Capacities

Output	287 hp @ 6,400 rpm	Torque	262 lb.-ft. @ 4,000 rpm
Drag coefficient	0.30	1st gear ratio	4.710
2nd gear ratio	2.840	3rd gear ratio	1.910
4th gear ratio	1.380	5th gear ratio	1.000
6th gear ratio	0.810	7th gear ratio	0.700
8th gear ratio	0.580	9th gear ratio	0.480
Reverse gear ratio	3.810	City/hwy	19 mpg/28 mpg
Curb weight	4,330 lbs.	GVWR	6,055 lbs.
Towing capacity	3,600 lbs.	Front legroom	41.1 "
Rear legroom	39.0 "	Third legroom	36.5 "
Front headroom	40.1 "	Rear headroom	39.6 "
Third headroom	38.7 "	Front hiproom	59.0 "
Rear hiproom	64.8 "	Third hiproom	49.5 "

The information contained in this package is provided to assist in assessing our vehicles and is for your information only. Prices and content information shown are subject to change and should be treated as estimates only. Information on the comparison vehicle is derived from available public sources and may not be completely current or accurate. No representations, warranties or guarantees are given in the information. Neither Chrysler nor the dealer will be liable for any reliance on the contents hereof. Please see salesperson for the most current information and other details. Actual pricing may vary. Reference DX05103297 6/2/2023

STANDARD EQUIPMENT Continued

Dimensions and Capacities (Continued)

Front shoulder room	63.8 "	Rear shoulder room	63.0 "
Third shoulder room	61.2 "	Passenger area volume	165.0 cu.ft.
Length	203.8 "	Body width	79.6 "
Body height	69.9 "	Wheelbase	121.6 "
Front track	68.3 "	Rear track	68.3 "
Turning radius	19.8 '	Fuel tank	19.0 gal.
Interior rear cargo volume	32.3 cu.ft.	Interior rear cargo volume seats folded	87.5 cu.ft.
Interior maximum rear cargo volume	140.5 cu.ft.		

The information contained in this package is provided to assist in assessing our vehicles and is for your information only. Prices and content information shown are subject to change and should be treated as estimates only. Information on the comparison vehicle is derived from available public sources and may not be completely current or accurate. No representations, warranties or guarantees are given in the information. Neither Chrysler nor the dealer will be liable for any reliance on the contents hereof. Please see salesperson for the most current information and other details. Actual pricing may vary. Reference DX05103297 6/2/2023

3.11
3.2201



SELECTED EQUIPMENT **2024 Chrysler Voyager**

Passenger Van LX (RUCL53)

RUCL53	Base Vehicle Price (RUCL53)	STD
Emissions		
NAS	50 State Emissions	OPT
Packages		
27E	Quick Order Package 27E	OPT
Powertrain		
ERC	Engine: 3.6L V6 24V VVT UPG I w/ESS	STD
DFH	Transmission: 9-Speed 948TE Automatic	STD
STDAX	3.25 Axle Ratio	STD
Z1A	GVWR: 6,055 lbs	STD
Wheels & Tires		
TMK	Tires: 235/65R17 BSW AS	STD
WFN	Wheels: 17" x 7" Aluminum	STD
Seats & Seat Trim		
H7	Cloth Bucket Seats	STD
CEQ	Black Seats	OPT
Other Options		
APA	Monotone Paint Application	STD
SDC	Touring Suspension	STD
UBC	Radio: Uconnect 5 w/7" Display	STD

The information contained in this package is provided to assist in assessing our vehicles and is for your information only. Prices and content information shown are subject to change and should be treated as estimates only. Information on the comparison vehicle is derived from available public sources and may not be completely current or accurate. No representations, warranties or guarantees are given in the information. Neither Chrysler nor the dealer will be liable for any reliance on the contents hereof. Please see salesperson for the most current information and other details. Actual pricing may vary. Reference DX05103297 6/2/2023

SELECTED EQUIPMENT Continued

Interior Colors For : Primary

X7	Black/Alloy/Black	OPT
----	-------------------	-----

Primary Colors For : Primary

PW7	Bright White Clearcoat	OPT
-----	------------------------	-----

Vehicle Subtotal

Destination

Vehicle Subtotal (including Destination)

The information contained in this package is provided to assist in assessing our vehicles and is for your information only. Prices and content information shown are subject to change and should be treated as estimates only. Information on the comparison vehicle is derived from available public sources and may not be completely current or accurate. No representations, warranties or guarantees are given in the information. Neither Chrysler nor the dealer will be liable for any reliance on the contents hereof. Please see salesperson for the most current information and other details. Actual pricing may vary. Reference DX05103297 6/2/2023



DIMENSIONS & CAPACITIES

2024 Chrysler Voyager

Passenger Van LX (RUCL53)

Output	287 hp @ 6,400 rpm
Torque	262 lb.-ft. @ 4,000 rpm
Drag coefficient	0.30
1st gear ratio	4.710
2nd gear ratio	2.840
3rd gear ratio	1.910
4th gear ratio	1.380
5th gear ratio	1.000
6th gear ratio	0.810
7th gear ratio	0.700
8th gear ratio	0.580
9th gear ratio	0.480
Reverse gear ratio	3.810
City/hwy	19 mpg/28 mpg
Curb weight	4,330 lbs.
GVWR	6,055 lbs.
Towing capacity	3,600 lbs.
Front legroom	41.1 "
Rear legroom	39.0 "
Third legroom	36.5 "
Front headroom	40.1 "
Rear headroom	39.6 "
Third headroom	38.7 "
Front hiproom	59.0 "
Rear hiproom	64.8 "
Third hiproom	49.5 "
Front shoulder room	63.8 "
Rear shoulder room	63.0 "
Third shoulder room	61.2 "
Passenger area volume	165.0 cu.ft.
Length	203.8 "
Body width	79.6 "
Body height	69.9 "
Wheelbase	121.6 "

The information contained in this package is provided to assist in assessing our vehicles and is for your information only. Prices and content information shown are subject to change and should be treated as estimates only. Information on the comparison vehicle is derived from available public sources and may not be completely current or accurate. No representations, warranties or guarantees are given in the information. Neither Chrysler nor the dealer will be liable for any reliance on the contents hereof. Please see salesperson for the most current information and other details. Actual pricing may vary. Reference DX05103297 6/2/2023

DIMENSIONS & CAPACITIES Continued

Front track	68.3 "
Rear track	68.3 "
Turning radius	19.8 '
Fuel tank	19.0 gal.
Interior rear cargo volume	32.3 cu.ft.
Interior rear cargo volume seats folded	87.5 cu.ft.
Interior maximum rear cargo volume	140.5 cu.ft.

The information contained in this package is provided to assist in assessing our vehicles and is for your information only. Prices and content information shown are subject to change and should be treated as estimates only. Information on the comparison vehicle is derived from available public sources and may not be completely current or accurate. No representations, warranties or guarantees are given in the information. Neither Chrysler nor the dealer will be liable for any reliance on the contents hereof. Please see salesperson for the most current information and other details. Actual pricing may vary. Reference DX05103297 6/2/2023



WARRANTY

2024 Chrysler Voyager

Passenger Van LX (RUCL53)

	Months/Distance
Basic	36 month/36,000 miles
Powertrain	60 month/60,000 miles
Corrosion Perforation	60 month/unlimited mileage
Roadside Assistance	60 month/60,000 miles

The information contained in this package is provided to assist in assessing our vehicles and is for your information only. Prices and content information shown are subject to change and should be treated as estimates only. Information on the comparison vehicle is derived from available public sources and may not be completely current or accurate. No representations, warranties or guarantees are given in the information. Neither Chrysler nor the dealer will be liable for any reliance on the contents hereof. Please see salesperson for the most current information and other details. Actual pricing may vary. Reference DX05103297 6/2/2023



AVAILABLE EQUIPMENT

2024 Chrysler Voyager

Passenger Van LX (RUCL53)

RUCL53	Base Vehicle Price (RUCL53)	STD
ORDER1	Initial Order Date: 07/14/2023	OPT
START1	Start-Up Date: 09/14/2023	OPT
FINAL1	Fleet Final Order Date: TBD	OPT
BUILD	Build-Out Date: TBD	OPT
NAS	50 State Emissions	OPT
27E	Quick Order Package 27E	OPT
ERC	Engine: 3.6L V6 24V VVT UPG I w/ESS	STD
DFH	Transmission: 9-Speed 948TE Automatic	STD
STDAX	3.25 Axle Ratio	STD
Z1A	GVWR: 6,055 lbs	STD
TMK	Tires: 235/65R17 BSW AS	STD
WFN	Wheels: 17" x 7" Aluminum	STD
H7	Cloth Bucket Seats	STD
CEQ	Black Seats	OPT
APA	Monotone Paint Application	STD
SDC	Touring Suspension	STD
UBC	Radio: Uconnect 5 w/7" Display	STD
UBN	Radio: Uconnect 5 Nav w/10.1" Display	OPT
NHK	Engine Block Heater	OPT
AAV	Fleet Security Group 2 Additional Key Fobs	OPT
AC5	SafetyTec 10.1" Touchscreen Display; 17" Inflatable Spare Tire; Advanced Brake Assist; Apple CarPlay; Blind Spot & Rear Cross Path Detection; Disassociated Touchscreen Display; Exterior Mirrors w/Supplemental Signals; Exterior Mirrors w/Heating Element; Gloss Black Exterior Mirrors; Google Android	OPT

The information contained in this package is provided to assist in assessing our vehicles and is for your information only. Prices and content information shown are subject to change and should be treated as estimates only. Information on the comparison vehicle is derived from available public sources and may not be completely current or accurate. No representations, warranties or guarantees are given in the information. Neither Chrysler nor the dealer will be liable for any reliance on the contents hereof. Please see salesperson for the most current information and other details. Actual pricing may vary. Reference DX05103297 6/2/2023

AVAILABLE EQUIPMENT Continued

Auto; GPS Antenna Input; GPS Navigation; HD Radio; Inflatable Spare Tire Kit; Integrated Center Stack Radio; Integrated Voice Command w/Bluetooth; ParkSense Rear Park Assist w/Stop; Portable Air Compressor w/o Sealant; Gloss Black Power Mirrors; (RT1) SiriusXM Guardian-Included Trial (B); SiriusXM w/360L; (UBN) Radio: Uconnect 5 Nav w/10.1" Display; USB Host Flip

XPG	MOPAR Paint Protection Film	OPT
ACK	MOPAR Roadside Emergency Kit <i>First Aid Kit; Reflecting Triangle; Tool Kit</i>	OPT
MKN	MOPAR Splash Guards - Vehicle Set <i>Front Splash Guards; Rear Splash Guards</i>	OPT
AWQ	SafetyTec Plus <i>7" Full Color TFT Display; Adaptive Cruise Control w/Stop & Go; Auto High Beam Headlamp Control; Lane Departure Warning Plus; Rain Sensitive Windshield Wipers</i>	OPT
RT1	SiriusXM Guardian-Included Trial (B) <i>1-Year Trial (Registration Required); 4G LTE Wi-Fi Hot Spot; Connected Travel & Traffic Services; For Details, Visit DriveUconnect.com; Global Telematics Box Module (TBM)</i>	OPT
WARANT	FCA 5 yr/100,000 Mile Powertrain Limited Warranty <i>All properly reported FCA Group LLC commercial fleet vehicles (NVDR type sale 3 and type sale 5) receive the 3 year 36,000 mile Basic Limited Warranty and the 5 year 100,000 mile Fleet Powertrain coverage. The 5 year/100,000 mile Fleet Powertrain coverage will go with the vehicle, so there will be no need to do warranty transfers and there will be no charge to second/subsequent owners to continue the warranty beyond the original owner. THIS LIMITED WARRANTY IS PROVIDED TO OWNERS of a Chrysler, Dodge, Jeep and Ram vehicle (excluding vehicles equipped with diesel engines) who purchased it through FCA US LLC specifically for Fleet Government Bid/Leases and Fleet Commercial/Lease orders only.</i>	OPT
JLP	GPS Antenna Input	STD
NHJ	Exterior Mirrors w/Heating Element	STD
RF5	Google Android Auto	STD
RF7	USB Host Flip	STD
RFP	Apple CarPlay	STD
RTF	Integrated Center Stack Radio	STD

The information contained in this package is provided to assist in assessing our vehicles and is for your information only. Prices and content information shown are subject to change and should be treated as estimates only. Information on the comparison vehicle is derived from available public sources and may not be completely current or accurate. No representations, warranties or guarantees are given in the information. Neither Chrysler nor the dealer will be liable for any reliance on the contents hereof. Please see salesperson for the most current information and other details. Actual pricing may vary. Reference DX05103297 6/2/2023



JOB RATING

2024 Chrysler Voyager

Passenger Van LX (RUCL53)

Performance predictions in this report represent an estimate of vehicle performance based on standard operating conditions. Variations in customer equipment, load configuration, ambient conditions, and/or operator driving techniques can cause significant variations in vehicle performance. These values are not representative of results that may be shown in actual dynamometer tests. This report should therefore be used as a guide for comparative vehicle performance.

Gross Vehicle Weight

Number of Passengers:	7
Weight of passengers:	1,050.00 lbs
Cargo length:	0 Inches
Cargo width:	0 Inches
Cargo height:	0 Inches
Cargo weight:	0 lbs
Weight of hitch:	0 lbs
Tongue weight:	0 lbs
Payload weight:	1,050.00 lbs
Curb Weight:	4,330.00 lbs
Gross Vehicle Weight:	5,380.00 lbs
Gross vehicle weight rating:	6,055.00 lbs
GVW vs. GVWR:	5,380.00 lbs<6,055.00 lbs

Gross Combined Weight

Weight of trailer:	0 lbs
Weight of trailer cargo:	0 lbs
Total weight of trailer:	0 lbs
Type of hitch:	None
Hitch weight:	0 lbs
Tongue weight:	0 lbs
Gross Vehicle Weight:	5,380.00 lbs
Adjusted gross vehicle weight:	5,380.00 lbs
Gross Combined Weight:	5,380.00 lbs
Gross combined weight rating:	0 lbs
GCW vs. GCWR:	5,380.00 lbs>0 lbs

The information contained in this package is provided to assist in assessing our vehicles and is for your information only. Prices and content information shown are subject to change and should be treated as estimates only. Information on the comparison vehicle is derived from available public sources and may not be completely current or accurate. No representations, warranties or guarantees are given in the information. Neither Chrysler nor the dealer will be liable for any reliance on the contents hereof. Please see salesperson for the most current information and other details. Actual pricing may vary. Reference DX05103297 6/2/2023

Seating Positions

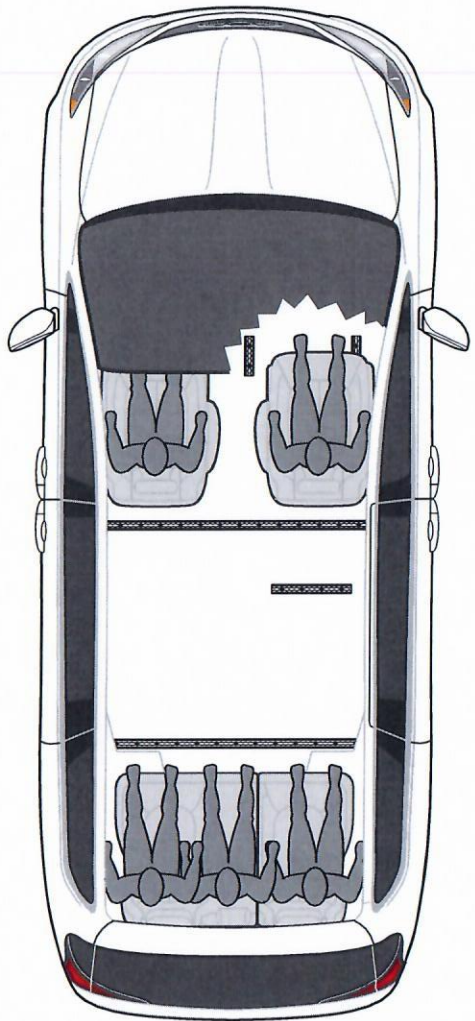

Possible Wheelchair Seating Positions

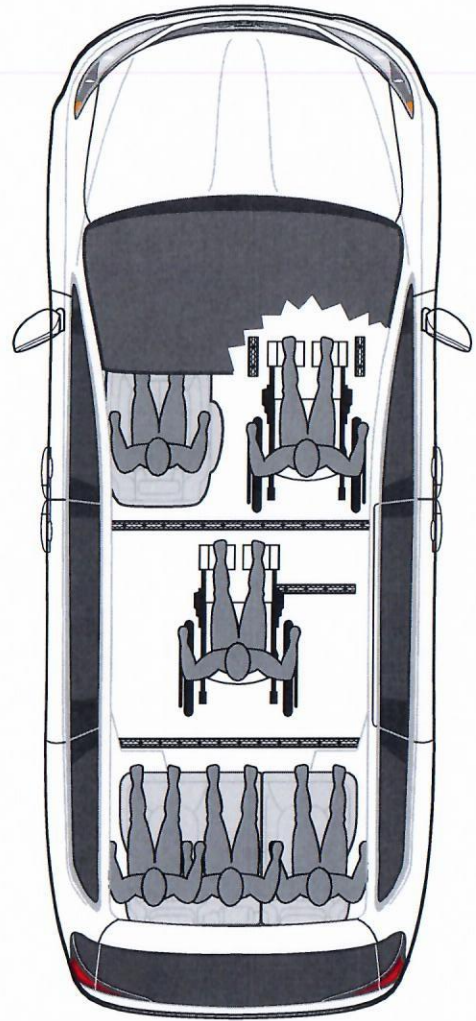

Introducing the **New Commercial Side-Entry** **Built on the Chrysler Voyager**



BraunAbility®

The Commercial Side-Entry wheelchair accessible vehicle has been a cost-effective, workhorse product for paratransit providers and transportation services. Leveraging almost 50 years of experience in mobility transportation solutions, BraunAbility introduces with the newest addition to the Commercial fleet, the Chrysler Voyager. The side-entry foldout has all the ADA-compliant features of the Dodge Grand Caravan but with 15% more cabin space for easier maneuverability, more seating positions, plus enhanced space at the toe pan for wheelchair footrests. The new conversion also features the much more durable thermoplastic (TPO) front, side and rear flares to absorb minor impacts while protecting the exterior look of the vehicle. An LED spotlight package for the ramp and cabin as well as an easy access footrest for rear seating adds to the overall ease of use for both operators and passengers.

- **15% more cabin space vs. Dodge Grand Caravan**
- **Seating for up to 7 ambulatory*[†]; up to 2 wheelchair positions**
- **Added space at front for wheelchair passenger footrests**
- **Hard-wearing TPO front, side and rear flares to absorb minor impacts**
- **Reinforced, heavy-duty swing-out ramp and latch**
- **Enhanced ADA lighting package**

* With optional aftermarket 2nd row 2-passenger folding bench seat



braunability.com/commercial

800.488.0359



Voyager Commercial Side-Entry



Standard Features

- ADA, FMVSS and CMVSS Compliant
- CARB approved
- 7-passenger vehicle (with optional aftermarket 2nd row 2-passenger folding bench seat)
- Lowered floor from toepan to rear axle
- 60" floor-to-ceiling at center of van
- 30" wide manual ramp with 1,000 lb capacity and swing out feature for ambulatory access
- Multiple wheelchair securement locations
- One wheelchair securement system
- Manual driver and passenger side sliding door providing 56" vertical opening (ADA compliant), passenger door provides clear opening width of 31" (excluding OEM grab handle)
- Step-and-Roll removable front passenger seat
- 3-passenger bench seat at rear with folding footrest
- Front passenger floor tracks for wheelchair securement, with 60" floor-to-ceiling height
- TPO plastic lower body panels with integrated steps
- Vinyl flooring with 3/8" underlayment, a thermoplastic honeycomb panel subfloor
- ADA-compliant park interlock
- ADA-compliant ramp and door entrance lighting
- Priority seating and wheelchair securement location decals
- Auxiliary wiring harnesses include fused circuits
- Emergency rear hatch release
- Easy maintenance interior trim package
- 19 gallon OEM fuel tank

Optional Features

- Aftermarket 2nd row 2-passenger folding bench seat
- DOT kit
- Additional set of tie-down straps

Dimensions

Door opening usable width (excluding OEM grab handle)	A	31"
Door opening usable height (at middle of door)	B	56"
Interior height at center of vehicle	C	60"
Interior height at driver and passenger position	D	60"
Ramp length	E	52"
Ramp width (usable clear opening)	F	30"
Ramp angle*	G	13.75°
Interior floor length (behind front seat strikers)	H	71"
Overall interior floor length (flat area)	I	98.5"
Interior width at passenger doors (doors closed)	J	64"
Interior width - ramp (deployed) to optional 2-passenger seat (stowed)	K	49"
Ground clearance (loaded) @ = GVWR lbs**	L	5"
Overall vehicle height (unloaded)	M	81"

Due to manufacturing tolerances both with the OEM vehicle and the conversion components, all dimensions may vary slightly from those shown.

* Ramp angle may vary based on chassis trim level and other environmental factors

** 5" clearance between the break-over angle position of the vehicle exhaust pipe and level ground when loaded to capacity

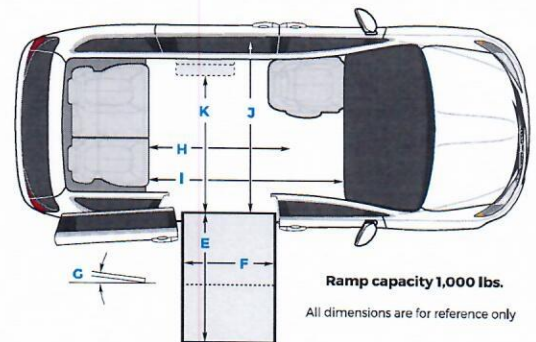
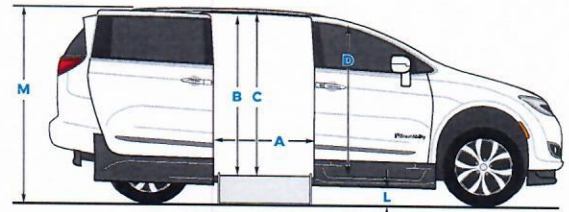

braunability.com/commercial

800.488.0359



3.27
3.28

QRT[®]-1 SERIES

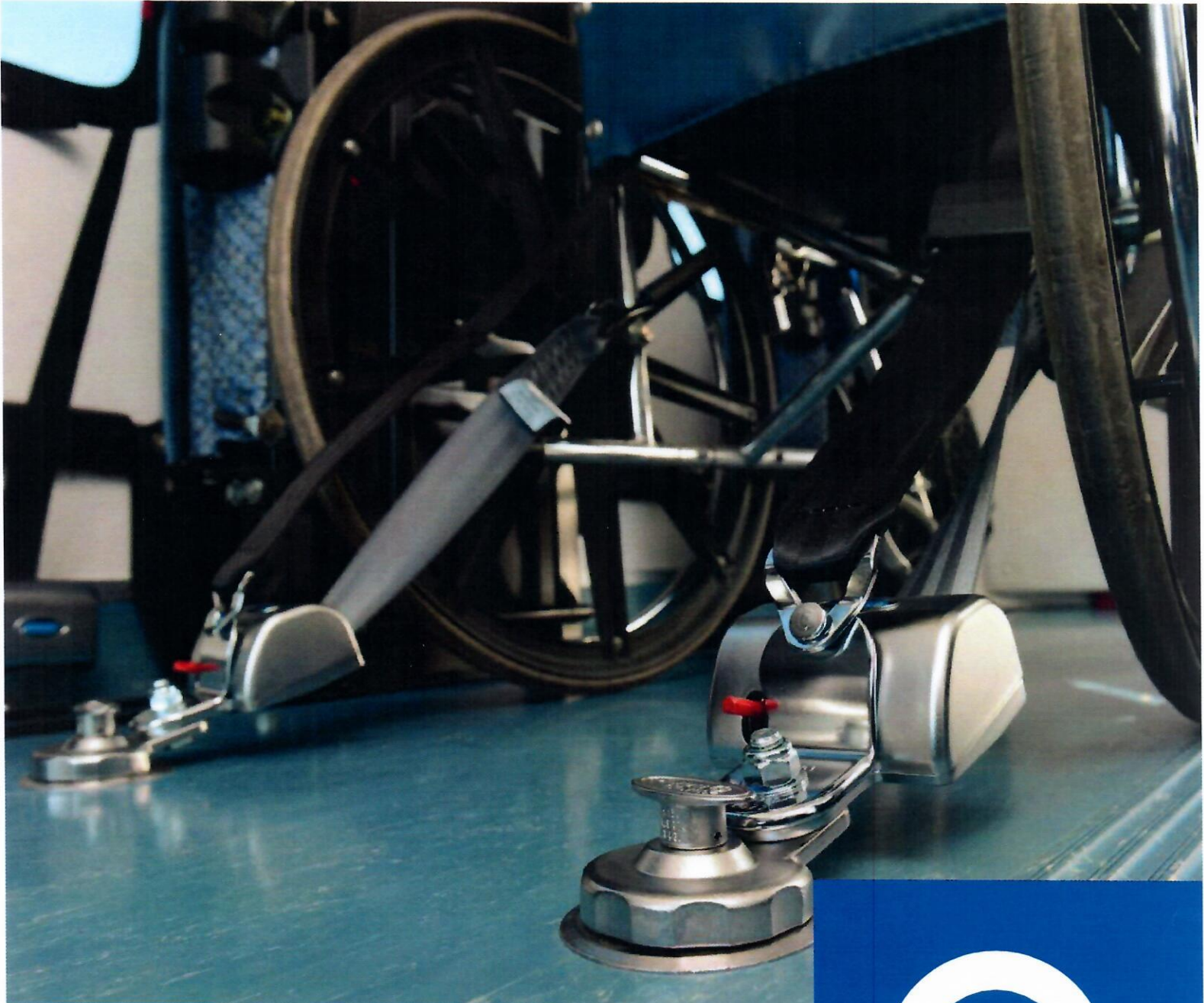

MAX / DELUXE / STANDARD
4-POINT SECUREMENT
WHEELCHAIR RETRACTORS



QRT[®]-1 SERIES

The Securement System That Changed Everything

The original 4-point wheelchair securement system, QRT-1 Series retractors defined the way passenger safety devices are designed and tested.

With a range of 3 different options to fit every need and every budget, the QRT-1 Series of retractors offer easy to use, effective 4-Point securement of wheelchairs for virtually any vehicle application.



QRT MAX

FULLY AUTOMATIC, premium knobless retractor that allows for one-handed operation.

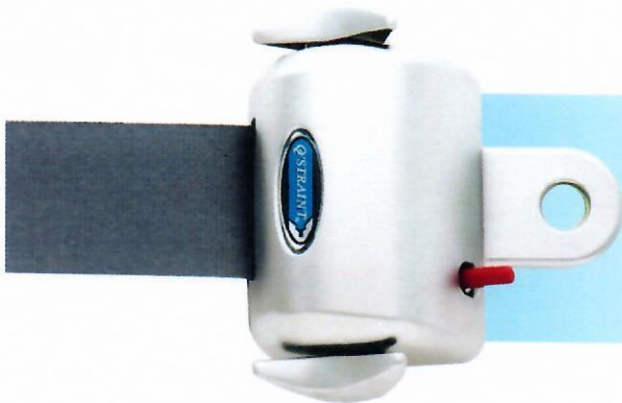

QRT DELUXE

SELF-LOCKING & SELF-TENSIONING retractor with ergonomic housing and dual tensioning knobs.

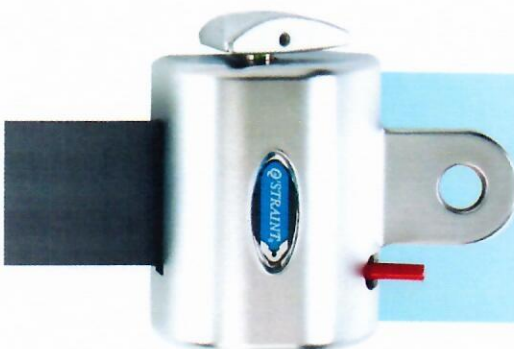

QRT STANDARD

SEMI-AUTOMATIC retractor that meets all industry standards and specifications.



More than 30 years ago, Q'STRAIT introduced the world's first fully integrated 4-Point wheelchair passenger securement system, now an industry standard the world over.

The QRT line of retractors are the linchpin of that system.



Anchorage Options

All QRT-1 Series Retractors are compatible with L-Track, L-Pockets and Slide 'N Click anchorages, or may be directly mounted to vehicle floors, seat legs or barriers.



Every QRT retractor is fully ADA compliant, and meets or exceeds all standards and regulations, including:

- SAE J2249, ISO 10542,
- FMVSS 209, 302, 210, 222
- CMVSS 209
- CSA Z605
- and 30mph/20g crash testing

L-TRACK / L-POCKETS

For kits that use L-Track or L-Pocket anchorages, QRT Series retractors feature our patented Positive Lock Indicator (PLI) that clearly indicates when the fitting is locked in the anchorage.

SLIDE 'N CLICK

For kits that include Slide 'N Click anchorages, QRT Series retractors feature a single-bolt SNC assembly and plunger that allows a full 360° rotation, eliminating anchorage alignment guesswork.

QRT-1 SERIES FEATURES COMPARISON

	MAX	DLX	STD	
Knobless, One-Handed Operation. No knobs to interfere with wheels and footrests.	●			
Dual Tensioning Knobs. Provides additional tensioning if needed.		●		
Single Tensioning Knob. Provides additional tensioning if needed.			●	
Automatic, Self-Locking. Allows easy, one-handed hook-up.	●	●		
Self-Tensioning. Retractors automatically take up 'slack'.	●	●		
Positive Lock Indicator. Patented feature clearly indicates when fitting is locked in anchorage.	●	●	●	
Interchangeable. Eliminates confusion: no right, left, front or rear locations.	●	●	●	
Low Profile & Compact. Elimination of mounting bracket allows retractors to fit under most footrests.	●	●	●	
Accommodates Larger Wheelchairs. Reduced overall length leaves more room for wheelchairs.	●	●		
Ultra-Durable. Hardened steel and coated zinc for maximum corrosion resistance.	●	●	●	
Universal Design. Accommodates virtually all wheelchair designs, including scooters.	●	●	●	
J-Hook. Reduces twisting of belts and ensures proper securement for all wheelchair designs.	●	●	●	
Foot Release Lever. Easy release eliminates the stress of bending down.	●	●	●	



WWW.QSTRAINT.COM/QRT-1-SERIES

© 2017 Q'STRAIN®. All Rights Reserved.
Q'STRAIN®, Q'STRAIN® logo, QRT-SERIES® and QRT™ are registered trademarks of Q'STRAIN®, Inc.

Q'STRAIN EUROPE

72-76 John Wilson Business Park
Whitstable, Kent, CT5 3QT
United Kingdom
Tel: +44 (0)1227 773035
Fax: +44 (0)1227 770035
Email: info@qstraint.co.uk

Q'STRAIN AMERICA

4031 NE 12th Terrace
Oakland Park, FL 33334
Tel: 800-987-9987
Fax: 954-986-0021
Email: qstraint@qstraint.com

Q'STRAIN AUSTRALIA

Tramanco Pty Ltd.
21 Shoebury Street,
Rocklea, Australia, QLD. 4106
Tel: +61 7 3892 2311
Fax: +61 7 3892 1819
Email: info@tramanco.com.au

Mobility Aid Track Mounting Dimensions

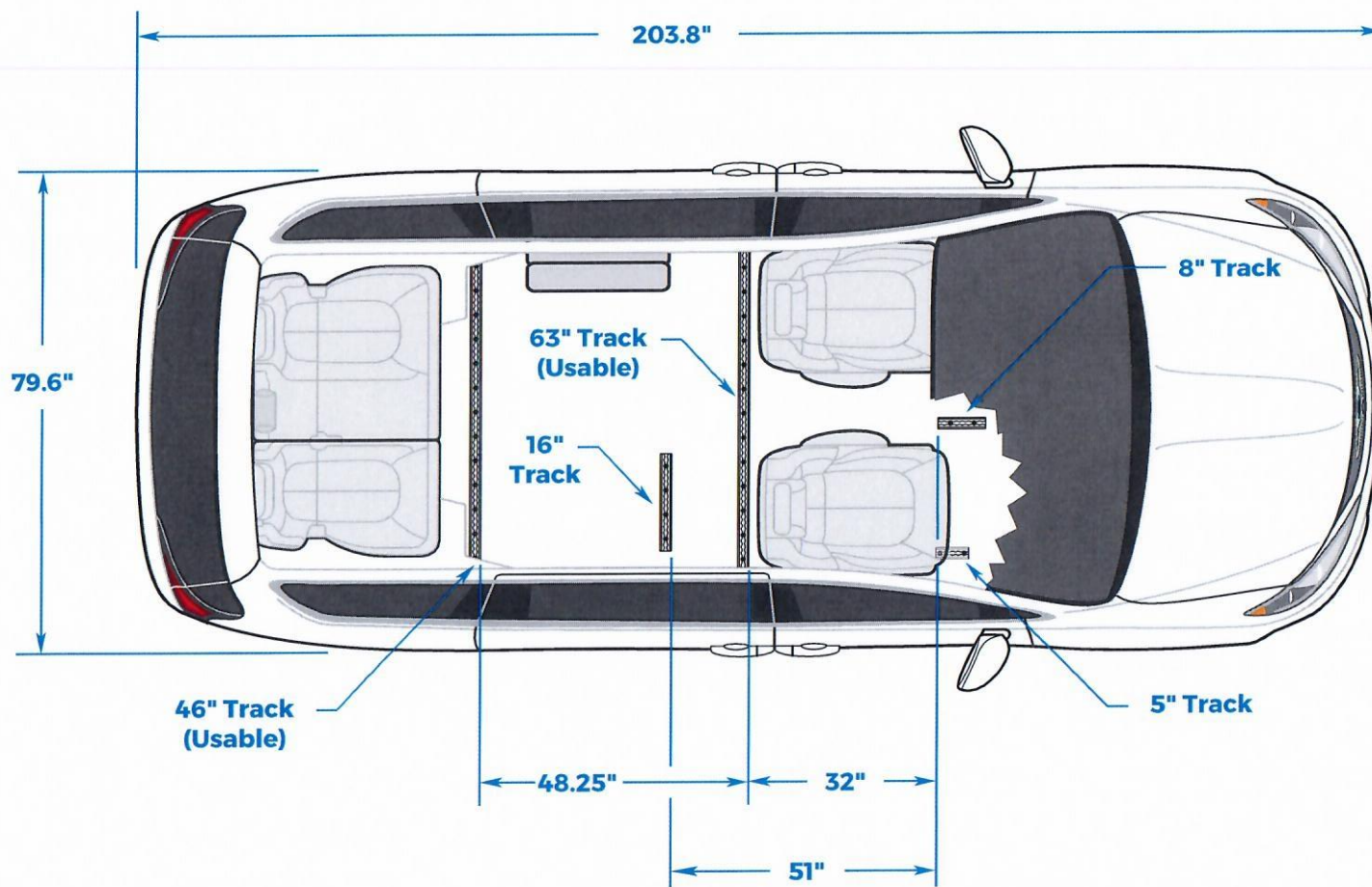

Notes: All Dimensions are Approximate.

RU Voyager ADA SE 2020 DIM01.ai

Commercial Infloor Simple Stow™



BraunAbility™

As the foremost name in mobility, we proudly present the new BraunAbility Commercial Infloor Simple Stow™. Rooted in our unwavering commitment to trust and reliability, this vehicle is more than transportation, it's an emblem of inclusivity. Boasting a redesigned infloor ramp assembly with extended handle for user-friendly operation, our ADA-Compliant Vehicle promises ease in mobility. The Commercial Infloor Simple Stow sets the gold standard for accessible travel from the brand that's earned the resounding endorsement of mobility technicians at an impressive 15:1* ratio. Safety is paramount, evident in crash tests exceeding Federal Motor Vehicle Safety Standards (FMVSS) and backed by a three-year limited warranty. Your journey to reliable and trustworthy mobility starts here.

* Based on a 2022 Dealer Service Technician Survey

- Easy to Use Ramp: Low effort deployment of infloor ramp with 60% less force
- User-Friendly Operation: An extended handle for convenient operation designed to reduce the need to bend down for most users
- Durability Tested: Enduring over 30,000 stow and deploy cycles at 150% of the recommended maximum operating speed, providing peace of mind for rigorous commercial use
- ADA-Compliant design with fixed 2-inch-high edge guards for simplicity and durability
- Versatility: Optional 2nd Row Freedman 2-passenger seat, catering to diverse transportation needs.
- Option for BuyAmerica compliant conversion is available

**BUILT
TO TRUST**



braunability.com/commercial

800.488.0359

Commercial Infloor Simple Stow™



Standard Features

- ADA, FMVSS and CMVSS Compliant
- CARB approved
- 7-passenger vehicle (with optional aftermarket 2nd row 2-passenger folding bench seat)
- Lowered floor from toepan to rear axle
- 60" floor-to-ceiling at center of van
- 30" wide manual infloor Simple Stow™ ramp - 1,000 lb capacity
- Multiple wheelchair securement locations
- One wheelchair securement system - Q-STRAINT M-Series
- OEM driver and passenger side power sliding door providing 56" vertical opening (ADA compliant), passenger door provides clear opening width of 31" (excluding OEM grab handle)
- Step-and-Roll removable front passenger seat
- 3-passenger bench seat at rear with folding footrest
- Front passenger floor tracks for wheelchair securement, with 60" floor-to-ceiling height
- TPO plastic lower body panels with integrated steps
- Vinyl flooring with 3/8" thermoplastic honeycomb panel subfloor
- ADA-compliant park interlock
- ADA-compliant ramp and door entrance lighting
- Priority seating and wheelchair securement location decals
- Auxiliary wiring harnesses include fused circuits
- Emergency rear hatch release
- Easy maintenance interior trim package
- 19 gallon OEM fuel tank

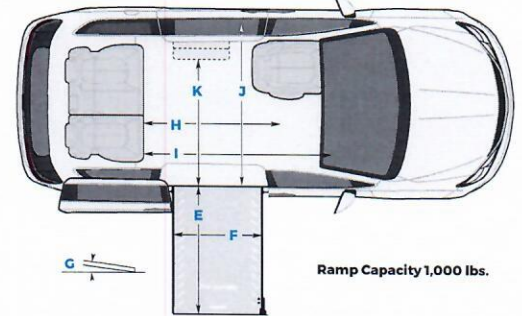
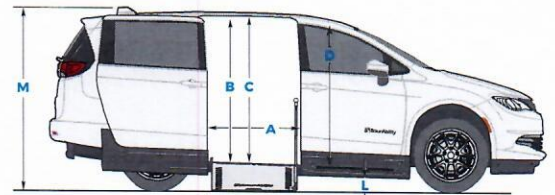

Ramp Capacity 1,000 lbs.

Optional Features

- Aftermarket 2nd row 2-passenger folding bench seat
- DOT kit
- Additional set of tie-downs

Dimensions

All dimensions are for reference only

Door Opening Usable Width	A	31.5"
Door Opening Usable Height (at middle of door - at airbag)	B	56.75" - 56"
Interior Height at Center of Van	C	60"
Interior Height at Driver and Passenger Position	D	60"
Ramp Length*	E	63.5"
Ramp Width (Usable Clear Opening)	F	30"
Ramp Angle**	G	11°
Interior Floor Length (Behind Front Seat Strikers)	H	66"
Overall Interior Floor Length (Flat Area)	I	98.5"
Interior Width at Passenger Doors (Doors Closed)	J	64"
Interior Width - Ramp (Deployed) to Optional 2-Passenger Seat (Stowed)	K	49"
Ground clearance at Lowest Point (Curb Weight)	L	5.6"
Overall Vehicle Height (Unloaded)	M	80"

Due to manufacturing tolerances both with the OEM vehicle and the conversion components, all dimensions may vary slightly from those shown.

* End of ramp to flat floor (including transition flap).

** Ramp angle may vary based on chassis trim level and other environmental factors.



braunability.com/commercial

800.488.0359



Limited Warranty



BraunAbility®

Braun Public Use - Lowered Floor Wheelchair Accessible Vehicle

IMPORTANT

This booklet contains BraunAbility® limited warranties.
It should be kept in your vehicle and presented to your Dealer
if any warranty service is needed.

LIMITED WARRANTY

WARRANTY COVERAGE AND WARRANTY COVERAGE TIME PERIODS

The BraunAbility® (“Braun”) warranty covers Braun’s modifications and alterations for associated parts for three (3) years or the first thirty six thousand (36,000) miles, whichever occurs first. In addition, the corrosion protection portion of this warranty applies to covered parts (see below) for 5 years or 100,000 miles, whichever occurs first. The 3 year/36,000 mile limited warranty covers substantial defects in materials and workmanship attributable to Braun of the conversion van frame, floor structural components, ramp, door and associated structural components, electrical components, including but not limited to switches, wires, connectors and the controller and interior appearance items such as floor covering and the lower door extension assemblies. The corrosion warranty covers substantial defects in materials and workmanship attributable to Braun of the metal fabrication on or of the frame, floor and lower door extensions. These warranty periods begin on the date that the product is delivered to the first retail purchaser by an independent, authorized dealer of Braun, or, if the dealer places the product into any type of service prior to retail sale, on the date the dealer first places the product in such service.

This limited warranty applies to the first consumer purchaser, and the next subsequent owner, only. This limited warranty may be transferred once during the warranty period. However, the subsequent owner must submit a warranty transfer form to Braun to make the warranty transfer effective. All rights and limitations within this warranty are applicable to the original and subsequent owner of the product. The subsequent owner’s warranty coverage period is the remaining balance of the warranty coverage period that the prior owner was entitled to under this limited warranty. Warranty transfer forms can be obtained from any independent, authorized dealer, which must be submitted to Braun within thirty (30) days from the subsequent owner’s purchase, and proof of the purchase date must be supplied with the form.

WHAT BRAUN WILL DO TO CORRECT PROBLEMS

In the event that a substantial defect in material or workmanship, attributable to Braun, is found to exist during the warranty coverage periods, it will be repaired or replaced, at Braun's option, without charge to the owner, in accordance with the terms, conditions and limitations of this limited warranty.

Braun's obligation to repair or replace defective materials or workmanship is the sole obligation of Braun under this limited warranty. Braun reserves the right to use new or remanufactured parts of similar quality to complete any work, and to make parts and design changes from time to time without notice to anyone. Braun reserves the right to make changes in the design or material of its products without incurring any obligation to incorporate such changes in any previously manufactured product. Braun makes no warranty as to the future performance of this product, and this limited warranty is not intended to extend to the future performance of the product. In addition, the owner's obligation to notify Braun, or one of its authorized, independent dealers, of a claimed defect does not modify any obligation placed on the owner to contact Braun directly when attempting to pursue remedies under state or federal law.

LIMITED WARRANTY

LIMITATIONS, EXCLUSIONS AND DISCLAIMER OF IMPLIED WARRANTIES

ANY IMPLIED WARRANTY THAT IS FOUND TO ARISE BY WAY OF STATE OR FEDERAL LAW, INCLUDING ANY IMPLIED WARRANTY OF MERCHANTABILITY OR ANY IMPLIED WARRANTY OF FITNESS, IS LIMITED IN DURATION TO THE TERMS OF THIS LIMITED WARRANTY AND IS LIMITED IN SCOPE OF COVERAGE TO THE SCOPE OF COVERAGE OF THIS LIMITED WARRANTY. Braun disclaims any express or implied warranty, including any implied warranty of fitness or merchantability, on items excluded from coverage as set forth in this limited warranty. Braun makes no warranty of any nature beyond that contained in this limited warranty. No one has authority to enlarge, amend or modify this limited warranty, and Braun does not authorize anyone to create any other obligation for it regarding this product. Braun is not responsible for any representation, promise or warranty made by any independent dealer or other person beyond what is expressly stated in this limited warranty. Any selling or servicing dealer is not Braun's agent, but an independent entity.

BRAUN SHALL NOT BE LIABLE FOR ANY INCIDENTAL OR CONSEQUENTIAL DAMAGES THAT MAY RESULT FROM BREACH OF THIS LIMITED WARRANTY OR ANY IMPLIED WARRANTY. THIS EXCLUSION OF CONSEQUENTIAL AND INCIDENTAL DAMAGES SHALL BE INDEPENDENT OF ANY FAILURE OF THE ESSENTIAL PURPOSE OF ANY WARRANTY, AND THIS EXCLUSION SHALL SURVIVE ANY DETERMINATION THAT THIS LIMITED WARRANTY OR ANY IMPLIED WARRANTY HAS FAILED OF ITS ESSENTIAL PURPOSE. This warranty does not cover, and in no event shall Braun be liable for towing charges, travel, lodging, or any other expense incurred due to the loss of use of the product or other reason.

Some states do not allow limitations on how long an implied warranty lasts, or the exclusion or limitation of incidental or consequential damages, so the above limitations or exclusions may not apply to you.

HOW TO GET SERVICE

To obtain warranty service the owner must do all of the following:

1. Notify an authorized service center, of the claimed defect attributable to Braun, within the warranty coverage period designated above;
2. Provide the notification mentioned in (1), above, within ten (10) days of when the owner discovered, or should have discovered, the claimed defect;
3. Promptly schedule an appointment with and take the product to an authorized service center for service; and
4. Pay any transportation costs and all expenses associated with obtaining warranty service.

Since Braun does not control the scheduling of service work at the independent dealerships you may encounter some delay in scheduling or completion of work. If you need assistance you may contact Braun, at 631 West 11th Street, Winamac, Indiana 46996; Customer Experience Group 1-800-488-0359.

If two (2) or more service attempts have been made to correct any covered defect that you believe impairs the value, use or safety of the product, or if it has taken longer than thirty (30) days for repairs to be completed, you must, to the extent permitted by law, notify Braun directly, in writing, at the above address, of the unsuccessful repair(s) of the alleged defect(s) so that Braun can become directly involved in providing service pursuant to the terms of this limited warranty.

LIMITED WARRANTY

WHAT IS NOT COVERED

This Limited Warranty does not cover any of the following: defects in materials, components or parts of the product not attributable to Braun, any material, component or part of the product that is warranted by another entity (Note: the written warranty provided by the manufacturer of the material, component or part is the direct responsibility of that manufacturer); items that are added or changed after the product leaves Braun's possession; additional items installed at any dealership, or other place of business, or by any other party, other than Braun; normal wear, tear, usage, maintenance, service, periodic adjustments, the effects of condensation or moisture from condensation; mold or any damage caused by mold; imperfections that do not affect the product for its intended purpose; items that are working as designed but that you are unhappy with; problems related to mis-operation, misuse, mishandling, neglect or abuse, including failure to maintain the product in accordance with the owner's manual, or other routine maintenance such as inspections, lubricating, adjustments, tightening of screws, sealing, wheel alignments or rotating tires; damage due to accident or collision, including any acts of weather or damage or corrosion due to the environment; theft, vandalism, fire, or other intervening acts not attributable to Braun; damage resulting from tire wear or tire failure; defacing, scratches, dents or chips on any interior or exterior surface of the product, including those caused by rocks or other road hazards, damage caused by off road use, overloading or alteration of the product, or any of its components or parts;

Defects and/or damage to interior and exterior surfaces and other appearance items may occur at the factory or when the product is in transit to a dealer. These items are usually detected and corrected at the factory or by the selling dealer prior to delivery to the retail customer. You must inspect the product for this type of damage when you take delivery. If you find any such defect or damage you must notify the selling dealer, or Braun, at the time of delivery to have these items covered by this limited warranty and to have work performed on the items at no cost to you as provided by this limited warranty.

EVENTS DISCHARGING BRAUN FROM OBLIGATION UNDER WARRANTY

The following shall completely discharge Braun from any express or implied warranty obligation to repair or replace anything and void this warranty: any rental or other commercial use or purchase of the product (as defined in this warranty), misuse, neglect, collision, accidents, failure to provide routine maintenance (See Owner's Manual), unauthorized alteration, off road use, damage from weather or the environment, theft, vandalism, tampering, fire, explosions, overloading the product and odometer tampering.

LEGAL REMEDIES

Any action to enforce any portion of this limited warranty, or any implied warranty, must be commenced within six (6) months after expiration of the warranty coverage period designated above or the action will be barred because of the passage of time. Any performance of repairs shall not suspend this limitation period from expiring. Any performance of repairs after the warranty coverage period has expired, or performance of repairs regarding any thing excluded from coverage under this limited warranty shall be considered "good will" repairs, and they will not alter the terms of this limited warranty, or extend any warranty coverage period or the filing limitation period in this paragraph. In addition, since it is reasonable to expect that the product will need some service during the warranty period, this warranty does not extend to future performance. It only sets forth what Braun will do and does not guarantee anything about the product for any time period. Nothing in this warranty, or any action of Braun, or any agent of Braun, shall be interpreted as an extension of any warranty period or the filing limitation period in this paragraph. Some states do not allow a reduction in the statute of limitations, so this reduction may not apply to you.

LIMITED WARRANTY

WARRANTY REGISTRATION and MISCELLANEOUS

Your warranty registration records should be completed and delivered to the appropriate companies, including the Braun Delivery Checklist & Warranty form. That form must be returned to Braun within twenty (20) days of purchase. The Braun warranty will not be registered unless this warranty registration is completed and received by Braun. Failure to file this warranty registration with Braun will not affect your rights under this limited warranty as long as you can present proof of purchase, but it can cause delays in obtaining the benefits of this limited warranty, and it changes the start date of the warranty to the date of final assembly of the product by Braun.

Braun agrees to repair or replace any of its factory installed parts found to have substantial defects within the appropriate warranty period designated above, provided that the repair is authorized by Braun and carried out by an authorized service center (a Braun labor schedule determines the cost allowance for repairs). Braun will not honor any warranty claim for repairs or replacement of parts unless the claim is submitted with the appropriate paperwork, and the work is completed by an independent, factory authorized service center. The appropriate paperwork can be obtained by written or phone contact with Braun at the contact information in this warranty.

Braun reserves the right to designate where any warranty work can be performed. Braun also reserves the right to examine any defective workmanship or part prior to giving any authorization for warranty work. Braun's return authorization procedure must be adhered to in order to process any warranty claims.

THIS WARRANTY GIVES YOU SPECIFIC LEGAL RIGHTS. YOU MAY ALSO HAVE OTHER RIGHTS THAT VARY FROM STATE TO STATE.

S.A.1
S.A.2
S.A.4

CHRYSLER



WARRANTY INFORMATION
2024

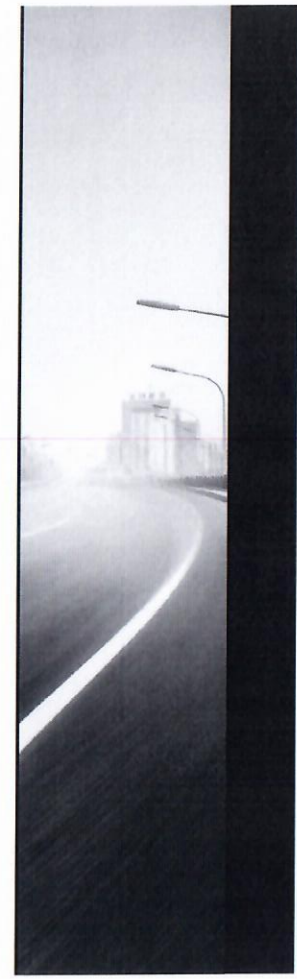



Please note that this new vehicle limited warranty contains a binding arbitration provision that may affect your legal rights, and you agree that, pursuant to the arbitration provision contained in this book, that either you or FCA US LLC may elect to resolve any dispute by neutral, binding arbitration and not by a court action. See the binding arbitration provision contained in "section 1.3" of this new vehicle limited warranty for additional information concerning the agreement to arbitrate. The binding arbitration provision contained in this warranty book does not affect any rights a consumer has to participate in any of FCA's nonbinding arbitration programs or any voluntary arbitration programs sponsored by any state or government agency.

Basic Limited Warranty Coverage 3 years/36,000 miles Specified Components 1 year/12,000 miles	Federal Emission Warranty 2 years/24,000 miles Specified Components 8 years/80,000 miles
Corrosion Limited Warranty All Panels 3 years/Unlimited miles Outer Panels 5 years/Unlimited miles	Emission Performance Warranty 2 years/24,000 miles Specified Components 8 years/80,000 miles
Powertrain Limited Warranty 5 years/60,000 miles	California Emission Warranty 3 years/50,000 miles 7 years/70,000 miles PHEV only - 15 years/150,000 miles
High Voltage Lithium-Ion Battery Limited Warranty *TZEV States - 10 years/150,000 miles Non-TZEV States - 8 years/100,000 miles	FCA US LLC Limited Emission Warranty PHEV - 8 years/100,000 miles

* See "Section 2.5"

1. YOUR LEGAL RIGHTS UNDER THESE LIMITED WARRANTIES

1.1 Incidental And Consequential Damages Not Covered4
 1.2 FCA US LLC Dispute Settlement Program4
 1.3 Voluntary Binding Arbitration Provision4

2. WHAT IS COVERED UNDER FCA US LLC'S WARRANTIES

2.1 Basic Limited Warranty6
 A. Who Is Covered6
 B. What Is Covered6
 C. Items Covered By Other Warranties6
 D. Towing Costs Are Covered Under Certain Circumstances6
 E. When It Begins6
 F. When It Ends6
 G. Registration And Operation Requirements7
 H. If You Move7
 I. Vehicle Registration Notice7
 2.2 Corrosion Limited Warranty7
 A. Who Is Covered7
 B. What Is Covered7
 C. How Long It Lasts8
 D. What Is Not Covered8
 2.3 Restraint System Limited Warranty (Vehicles Sold And Registered In The State Of Kansas Only)8
 2.4 Powertrain Limited Warranty8

A. Who Is Covered8
 B. What Is Covered8
 C. How Long It Lasts8
 D. Towing Costs Are Covered9
 E. Parts Covered9
 F. Other Provisions Of This Powertrain Limited Warranty ..10
 2.5 High Voltage Lithium-Ion Battery Limited Warranty10
 A. Who Is Covered10
 B. How Long It Lasts10
 C. Towing Costs Are Covered10
 D. Gradual Capacity Loss10
 E. High Voltage Lithium-Ion Battery Exclusions10

3. WHAT IS NOT COVERED

3.1 Modifications Not Covered12
 A. Some Modifications Do Not Void The Warranties But Are Not Covered12
 B. Modifications That WILL Void Your Warranties12
 3.2 Environmental Factors Not Covered12
 3.3 Maintenance Costs Not Covered13
 3.4 Racing Not Covered13
 3.5 Certain Kinds Of Corrosion Not Covered13
 3.6 Other Exclusions13
 3.7 Total Loss, Salvage, Junk, Or Scrap Vehicles Not Covered ...14
 3.8 Restricted Warranty14

4. OTHER TERMS OF YOUR WARRANTIES

4.1	Exchanged Parts May Be Used In Warranty Repairs	15
4.2	Pre-Delivery Service	15
4.3	Production Changes	15

5. FEDERAL EMISSION WARRANTY

5.1	Parts Covered For Two Years Or 24,000 Miles	16
5.2	Parts Covered For Eight Years Or 80,000 Miles	16
5.3	Emission Performance Warranty	17
5.4	California Emission Warranty	17
A.	Your Warranty Rights And Obligations Applies Only To Vehicles Certified For Sale And Registered In The State Of California Or A State That Has Adopted California Regulations	17
B.	Owner's Warranty Responsibilities	18
C.	Getting Service Under The California Emission Warranty	18
D.	Manufacturer's Warranty Coverage	19

6. WHERE TO TAKE YOUR VEHICLE

6.1	In the United States And US Possessions And Territories For Warranty Purposes	21
6.2	In Canada And Mexico	21
6.3	In A Foreign Country Outside Of North America	21
6.4	How To Get Roadside Assistance Service — U.S. Or Canada Only *	21
A.	Who Is Covered	21

B.	What To Do	22
C.	If Unable To Contact Roadside Assistance	22
D.	Covered Services	23
6.5	Emergency Warranty Repairs	23
6.6	Getting Service Under The Federal Emission Performance Warranties	23
A.	What To Do	23
B.	Further Steps You Can Take, And How To Get More Information	24

7. HOW TO DEAL WITH WARRANTY PROBLEMS

7.1	Steps To Take	25
A.	In General	25
B.	What FCA US LLC Will Do	25
C.	Voluntary Non-Binding Arbitration Process	25
D.	Notice Under State Lemon Laws	26
E.	California Residents Only	26
7.2	Helpful Addresses And Telephone Numbers	27

8. OPTIONAL SERVICE CONTRACT**9. MAINTENANCE**

9.1	General Information	29
9.2	Where To Go For Maintenance	29

1. YOUR LEGAL RIGHTS UNDER THESE LIMITED WARRANTIES

The warranties contained in this booklet are the only express warranties that FCA US LLC ("FCA US") makes for your vehicle. **These warranties give you specific legal rights. You may also have other rights that vary from state to state.** For example, you may have some implied warranties, depending on the state where your vehicle was sold or is registered.

These implied warranties are limited, to the extent allowed by law, to the time periods covered by the express written warranties contained in this booklet.

If you use your vehicle primarily for business or commercial purposes, then these implied warranties do not apply and FCA US LLC completely disclaims them to the extent allowed by law. The implied warranty of fitness for a particular purpose does not apply if your vehicle is used for racing, even if the vehicle is equipped for racing.

Some states do not allow limitations on how long an implied warranty lasts, so the above limitations may not apply to you.

1.1 INCIDENTAL AND CONSEQUENTIAL DAMAGES NOT COVERED

Your warranties do not cover any incidental or consequential damages connected with your vehicle's failure, either while under warranty or afterward.

Examples of such damages include:

- Lost time

- Inconvenience
- The loss of the use of your vehicle
- The cost of rental vehicles, gasoline, telephone, travel, or lodging
- The loss of personal or commercial property
- The loss of revenue

Some states do not allow incidental or consequential damages to be excluded or limited, so this exclusion may not apply to you.

1.2 FCA US LLC DISPUTE SETTLEMENT PROGRAM

FCA US LLC offers a dispute settlement program under two options for customers. First, you may submit your claim to the National Center for Dispute Settlement (NCDS). For more information on the NCDS program, please see "section 7.1 C". Second, if you prefer not to submit your claim to NCDS, or you are not satisfied with the result from NCDS, then you agree to resolve your dispute with FCA US LLC through binding arbitration as defined in "section 1.3".

1.3 VOLUNTARY BINDING ARBITRATION PROVISION

Please carefully read this voluntary binding arbitration provision, which applies to any dispute between you and FCA US LLC and its affiliates (together "FCA", "we" or "us"). If you have a concern or dispute, please send a written notice describing it and your desired resolution to FCA US LLC Office of the General Counsel, 1000 Chrysler Drive, CIMS 485-13-62, Auburn Hills, MI 48326-2766. This binding arbitration provision does not affect any rights a consumer has to participate in

any of FCA US LLC's nonbinding arbitration programs or any voluntary arbitration programs sponsored by any state or government agency.

If your concern or dispute is not resolved within 60 days, you agree that any dispute arising out of or relating to any aspect of the relationship between you and FCA US LLC will not be decided by a judge or jury but instead by a single arbitration administered by the **American Arbitration Association (AAA)** under its **Consumer Arbitration Rules** in effect at the time you signed the Agreement to Arbitrate.

This includes claims arising out of your warranty and claims arising before this agreement, such as claims related to statements about our products.

FCA US LLC will pay all AAA fees and costs for any arbitration, which will be held in the city or county of your residence. To learn more about the rules and how to begin an arbitration, you may call any AAA office or go to www.adr.org.

The arbitrator may only resolve disputes between you and FCA US LLC and may not consolidate claims without the consent of all parties. You and FCA US LLC may bring claims against the other only in your or its individual capacity and not as a plaintiff or class member in any class or representative action. The arbitrator cannot hear class or representative claims on behalf of others purchasing or leasing FCA US LLC vehicles. If a court or arbitrator decides that any part of this agreement to arbitrate cannot be enforced as to a particular claim for relief or remedy (such as declaratory relief), then that claim or remedy (and only that claim or remedy) shall be severed and must be brought in court and any other claims must be arbitrated.

If you prefer, you may instead take an individual dispute to small claims court.

You may opt out of arbitration within 30 days of taking delivery of the vehicle and signing the Arbitration Acknowledgment Form at the dealer. To opt out of the binding arbitration program, send a letter to: FCA US LLC Office of the General Counsel, 1000 Chrysler Drive, CIMS 485-13-62, Auburn Hills, MI 48326-2766, stating your name, Vehicle Identification Number (VIN), and intent to opt out of the arbitration provision. If you do not opt out, then this provision to arbitrate is binding.

2. WHAT IS COVERED UNDER FCA US LLC'S WARRANTIES

2.1 BASIC LIMITED WARRANTY

A. WHO IS COVERED

You are covered by the Basic Limited Warranty if you are a purchaser for use of the vehicle.

B. WHAT IS COVERED

The Basic Limited Warranty covers the cost of all parts and labor needed to repair any item on your vehicle when it left the manufacturing plant that is defective in material, workmanship or factory preparation. There is no list of covered parts since the only exceptions are the parts listed in "section 2.1 C". These warranty repairs or adjustments, including all parts and labor connected with them, will be made by an authorized Chrysler, Dodge, Jeep®, or Ram dealer at no charge, using new or remanufactured parts.

C. ITEMS COVERED BY OTHER WARRANTIES

The following are covered by separate warranties offered by their manufacturers. They are **not covered** by the Basic Limited Warranty:

- Tires
- Headphones

- Items added or changed after your vehicle left the manufacturing plant, such as accessories or protection products, or items changed because of customization or van conversion.

Be sure you get a copy of any warranty that applies to these items from the manufacturer of the product.

D. TOWING COSTS ARE COVERED UNDER CERTAIN CIRCUMSTANCES

Roadside Assistance covers the cost of towing your vehicle to the nearest authorized Chrysler, Dodge, Jeep®, or Ram dealer if your vehicle becomes disabled as a result of a mechanical breakdown. If you choose to go to another dealer, you will be responsible for the cost. Refer to "section 6.4" for information on how to get towing service in the United States and Canada.

E. WHEN IT BEGINS

The Basic Limited Warranty begins on either of the following dates, whichever is earlier:

- The date you take delivery of the vehicle.
- The date when the vehicle was first put into use, for example, as a dealer "demo" or as a FCA US LLC company vehicle.

F. WHEN IT ENDS

All Vehicles

The Basic Limited Warranty lasts for three years from the date it begins or for 36,000 miles on the odometer, whichever occurs first.

The following items are covered only for one year or for 12,000 miles on the odometer, whichever occurs first:

- Brakes (rotors, pads, linings, and drums)
- Bulbs
- Clutch Discs or Modular Clutch Assembly (if equipped)
- Wheel Alignment
- Wheel Balancing
- Windshield and Rear Window
- Wiper Blades

G. REGISTRATION AND OPERATION REQUIREMENTS

The Basic Limited Warranty covers your vehicle only if:

- The vehicle was manufactured for sale and registered in the US, US Possessions and Territories.
- The vehicle is driven mainly in the US, US Possessions and Territories, Canada and Mexico.
- The vehicle is operated and maintained in the manner described in your Owner's Manual.

EXCEPT WHERE SPECIFICALLY REQUIRED BY LAW, THERE IS NO WARRANTY COVERAGE FOR THIS VEHICLE IF IT IS SOLD OR REGISTERED OUTSIDE OF THE UNITED STATES, UNITED STATES POSSESSIONS AND TERRITORIES.

This policy does not apply to vehicles that have received authorization for export from FCA US LLC. Dealers may not give authorization for export. Consult an authorized dealer to determine this vehicle's warranty coverage if you have any questions.

This policy does not apply to vehicles registered to US government officials or military personnel on assignment outside of the United States.

H. If You Move

If you move to another country, be sure to contact the FCA US LLC Customer Assistance Center in "section 7.2" and the customs department of the destination country before you move. Vehicle importation rules vary considerably from country to country. You may be required to present documentation of your move to FCA US LLC in order to continue your warranty coverage. You may also be required to obtain documentation from FCA US LLC in order to register your vehicle in your new country.

I. VEHICLE REGISTRATION NOTICE

If your vehicle is registered outside of the United States, and you have not followed the procedure set out above, your vehicle will no longer be eligible for warranty coverage of any kind. Vehicles registered to United States government officials or military personnel on assignment outside of the US will continue to be covered.

2.2 CORROSION LIMITED WARRANTY

A. Who Is Covered

You are covered by the Corrosion Limited Warranty if you are a purchaser for use of the vehicle.

B. What Is Covered

The Corrosion Limited Warranty covers the cost of all parts and labor needed to repair or replace any sheet metal panels that get holes from rust or other corrosion. If a hole occurs because of something

other than corrosion, this warranty does not apply. Cosmetic or surface corrosion may be covered under the warranty. The cause of surface corrosion will determine if there is coverage. Cosmetic or surface corrosion resulting from stone chips or scratches in the paint is not covered.

For more details on what is not covered by this warranty, refer to "section 3.5".

C. How Long It Lasts

The Corrosion Limited Warranty starts when your Basic Limited Warranty begins under "section 2.1 E".

This warranty has two time-and-mileage limits:

- For sheet metal panels, the limit is three years, with no mileage limit.
- For an outer-body sheet metal panel, one that is finish-painted and that someone can see when walking around the vehicle, the limit is five years, with no mileage limit.

D. What Is Not Covered

Please note that while the standard Corrosion Limited Warranty applies to defects in material and/or workmanship, it does not cover the vehicle's matte finish appearance (if equipped).

Maintaining the matte finish appearance is solely the responsibility of the vehicle owner as described in your Owner's Manual.

2.3 RESTRAINT SYSTEM LIMITED WARRANTY (VEHICLES SOLD AND REGISTERED IN THE STATE OF KANSAS ONLY)

For vehicles sold and registered in the state of Kansas, seat belts and related seat belt components are warranted against defects in workmanship and materials for 10 years, regardless of mileage. This warranty does not cover replacement of seat belts and related components required as the result of collision.

2.4 POWERTRAIN LIMITED WARRANTY

A. Who Is Covered

You are covered by the Powertrain Limited Warranty if you are a purchaser for use of the vehicle.

B. What Is Covered

The Powertrain Limited Warranty covers the cost of all parts and labor needed to repair a powertrain component listed in "section 2.4 E" that is defective in workmanship and materials.

C. How Long It Lasts

The Powertrain Limited Warranty lasts for up to five years or 60,000 miles on the odometer, whichever occurs first, calculated from the start date of the Basic Limited Warranty, as set forth in "section 2.1 E".

D. TOWING COSTS ARE COVERED

Roadside Assistance covers the cost of towing your vehicle to the nearest authorized Chrysler, Dodge, Jeep®, or Ram dealer if your vehicle cannot be driven because a covered part has failed.

If you choose to go to another dealer, you will be responsible for the cost. Refer to "section 6.4" for information on how to get towing service in the United States and Canada.

E. PARTS COVERED

The Powertrain Limited Warranty covers these parts and components of your vehicle's powertrain supplied by FCA US LLC:

NOTE:

MANUAL TRANSMISSION CLUTCH PARTS ARE NOT COVERED UNDER THE POWERTRAIN LIMITED WARRANTY.

Gasoline Engine

Cylinder block and all internal parts; cylinder head assemblies; timing case, timing chain, timing belt, gears and sprockets; vibration damper; oil pump; water pump and housing; intake and exhaust manifolds; flywheel with starter ring gear; core plugs; valve covers; oil pan; turbocharger housing and internal parts; turbocharger wastegate actuator; supercharger; serpentine belt tensioner; and seals and gaskets for listed components only.

Transmission

Transmission case and all internal parts; torque converter; drive/flex plate; transmission range switch; speed sensors; pressure sensors;

transmission control module; bell housing; oil pan; and seals and gaskets for listed components only.

Front-Wheel Drive (FWD)

Transaxle case and all internal parts; axle shaft assemblies; constant velocity joints and boots; differential cover; oil pan; transaxle speed sensors; transaxle solenoid assembly; PRNDL position switch; transaxle electronic controller; torque converter; and seals and gaskets for listed components only.

All-Wheel Drive (AWD)

Power transfer unit and all internal parts; viscous coupler; axle housing and all internal parts; constant velocity joints and boots; driveshaft and axle shaft assemblies; differential carrier assembly and all internal parts; output ball bearing; output flange; end cover; overrunning clutch; vacuum motor; torque tube; pinion spacer and shim; and seals and gaskets for listed components only.

Rear-Wheel Drive (2WD)

Rear axle housing and all internal parts; axle shafts; axle shaft bearings; drive shaft assemblies; drive shaft center bearings; universal joints and yokes; and seals and gaskets for listed components only.

Four-Wheel Drive (4WD)

Transfer case and all internal parts; transfer case control module and shift mode motor assembly; axle housing and all internal parts; axle shafts; axle shaft bearings; drive shafts assemblies (front and rear); drive shaft center bearings; universal joints and yokes; disconnect housing assembly; and seals and gaskets for the listed components only.

F. OTHER PROVISIONS OF THIS POWERTRAIN LIMITED WARRANTY

For all other terms of the New Vehicle Limited Warranty that apply to the Powertrain Limited Warranty, refer to "section 1" (Your Legal Rights Under These Limited Warranties) and "section 3" (What Is Not Covered) for further information.

2.5 HIGH VOLTAGE LITHIUM-ION BATTERY LIMITED WARRANTY

A. WHO IS COVERED

You are covered by the High Voltage Lithium-Ion Battery Limited Warranty if you are a purchaser for use of the vehicle.

B. HOW LONG IT LASTS

- The High Voltage Lithium-Ion Battery Limited Warranty coverage is 10 years or 150,000 miles on the odometer, whichever occurs first, calculated from the start date of the Basic Limited Warranty, as set forth in "section 2.1 E".
- *This applies to vehicles certified for sale and registered in the state of California or one of the following states that adopt California TZEV regulations:

Colorado	Massachusetts	Oregon
Connecticut	New Jersey	Rhode Island
Maine	New York	Vermont
Maryland		

- The High Voltage Lithium-Ion Battery Limited Warranty coverage is eight years or 100,000 miles on the odometer, whichever occurs first, calculated from the start date of the Basic Limited Warranty, as set forth in "section 2.1 E". This applies to vehicles certified for sale and registered in states not adopting California TZEV regulations

C. TOWING COSTS ARE COVERED

Roadside Assistance covers the cost of towing your vehicle to the nearest authorized Chrysler, Dodge, Jeep®, or Ram dealer if your vehicle cannot be driven because a covered part has failed.

If you choose to go to another dealer, you will be responsible for the cost. Refer to "section 6.4" for information on how to get towing service in the United States and Canada.

D. GRADUAL CAPACITY LOSS

Like all batteries, the high voltage lithium-ion battery will experience gradual capacity loss with time and use. The loss of battery capacity due to or resulting from gradual capacity loss is not covered under the High Voltage Lithium-Ion Battery Limited Warranty.

E. HIGH VOLTAGE LITHIUM-ION BATTERY EXCLUSIONS

Your warranties do not cover the costs of repairing damage or conditions caused by any of the following:

- Physically damaging the high voltage lithium-ion battery or intentionally attempting to reduce the life of the high voltage lithium-ion battery

- Leaving your vehicle for over 30 days where the high voltage lithium-ion battery reaches a zero or near zero state of charge
- Neglecting to follow correct charging procedures as recommended in your Owner's Manual
- Use of incompatible charging devices as recommended in your Owner's Manual
- Opening the high voltage lithium-ion battery enclosure or having it serviced by someone other than an authorized repair facility certified technician
- Exposing the high voltage lithium-ion battery to contact with a direct flame
- Exposing your vehicle to ambient temperatures above 140 °F (60 °C) for over 24 hours

3. WHAT IS NOT COVERED

3.1 MODIFICATIONS NOT COVERED

A. SOME MODIFICATIONS DO NOT VOID THE WARRANTIES BUT ARE NOT COVERED

Certain changes that you might make to your vehicle do not, by themselves, void the warranties described in this booklet. Examples of some of these changes are:

- Installing non-FCA US LLC parts, components, or equipment such as a non-FCA US LLC radio or cruise control.
- Using special non-FCA US LLC materials or additives.
- Modifying the front fascia/bumper, vehicle body structure, or adding aftermarket side steps or running boards.
- Replacing windshields on vehicles equipped with Advanced Driver Assist systems with non-FCA US LLC parts.
- Using aftermarket collision parts.
- Attaching or installing any aftermarket accessories, including transparent material (e.g. glass tinting) or aftermarket grilles.

NOTE:

Non-FCA US LLC parts can also impact downstream or other related safety systems.

Your warranties do not cover any part that was not on your vehicle when it left the manufacturing plant or is not certified for use on your vehicle. Nor do they cover the costs of any repairs or adjustments that

might be caused or needed because of the installation or use of non-FCA US LLC parts, components, equipment, materials, or additives.

Performance or racing parts are considered to be non-FCA US LLC parts. Repairs or adjustments caused by their use are not covered under your warranties.

Examples of the types of alterations not covered are:

- Installing accessories, except for genuine FCA US LLC/Mopar® accessories installed by an authorized Chrysler, Dodge, Jeep®, or Ram dealer.
- Applying rustproofing or other protection products.
- Changing the vehicle's configuration or dimensions, such as converting the vehicle into a limousine or food service vehicle.
- The use of any refrigerant that FCA US LLC has not approved.

B. MODIFICATIONS THAT WILL VOID YOUR WARRANTIES

These actions will void your warranties:

- Disconnecting, tampering with, or altering the odometer, unless your repairing technician follows the legal requirements for repairing or replacing odometers.
- Attaching any device that disconnects the odometer.

3.2 ENVIRONMENTAL FACTORS NOT COVERED

Your warranties do not cover damage caused by environmental factors such as airborne fallout, bird droppings, insect damage, chemicals, tree sap, salt, ocean spray, acid rain, and road hazards. Nor do

your warranties cover damage caused by hailstorms, windstorms, tornadoes, sandstorms, lightning, floods, and earthquakes.

Your warranties do not cover conditions resulting from anything impacting the vehicle. This includes cracks and chips in glass, scratches and chips in painted surfaces, or damage from collision.

3.3 MAINTENANCE COSTS NOT COVERED

Your warranties do not cover the costs of repairing damage caused by poor or improper maintenance. Nor do they cover damage caused by the use of contaminated fuels, or by the use of fuels, oils, lubricants, cleaners or fluids other than those recommended in your Owner's Manual.

The warranties do not cover the costs of your vehicle's normal or scheduled maintenance, the parts and services that all vehicles routinely need.

Some of these parts and services, which your warranties do not cover, include:

- Lubrication
- Engine tune-ups
- Replacing filters, coolant, spark plugs, or fuses (unless those costs result from a covered repair)
- Cleaning and polishing
- Replacing worn wiper blades, worn brake pads and linings, or clutch linings

3.4 RACING NOT COVERED

Your warranties do not cover the costs of repairing damage or conditions caused by racing, nor do they cover the repair of any defects that are found as the result of participating in a racing event.

3.5 CERTAIN KINDS OF CORROSION NOT COVERED

Your warranties do not cover the following:

- Corrosion caused by accident, damage, abuse, or vehicle alteration
- Surface corrosion caused by such things as industrial fallout, sand, salt, hail, ocean spray, and stones
- Corrosion caused by the extensive or abnormal transport of caustic materials like chemicals, acids, and fertilizers
- Corrosion of special bodies, body conversions, or equipment that was not on your vehicle when it left the manufacturing plant or was not supplied by FCA US LLC

3.6 OTHER EXCLUSIONS

Your warranties do not cover the costs of repairing damage or conditions caused by any of the following:

- Fire or accident
- Abuse or negligence
- Misuse, for example, driving over curbs or overloading
- Tampering with the emission systems, or with a part that could affect the emission systems

- Use of used parts, even if they were originally supplied by FCA US LLC; however, authorized FCA US LLC/Mopar® remanufactured parts are covered
- Windshield or rear window damage from external objects
- Any changes made to your vehicle that do not comply with FCA US LLC
- Using any fluid that does not meet the minimum recommendations in your Owner's Manual

3.7 TOTAL LOSS, SALVAGE, JUNK, OR SCRAP VEHICLES NOT COVERED

A vehicle has no warranty coverage of any kind if:

- The vehicle is declared a total loss by an insurance company.
- The vehicle is rebuilt after being declared a total loss by an insurance company.
- The vehicle is issued a certificate of title indicating that it is designated as "salvage", "junk", "rebuilt", "scrap", or some similar word.

FCA US LLC will deny warranty coverage without notice if it learns that a vehicle is ineligible for coverage for any of these reasons.

This exclusion does not apply to emission warranties or to recall campaigns.

3.8 RESTRICTED WARRANTY

FCA US LLC may restrict the warranty on your vehicle if the vehicle is not properly maintained, or if the vehicle is abused or neglected, and the abuse or neglect interferes with the proper functioning of the vehicle. If the warranty is restricted, coverage may be denied or subject to approval by FCA US LLC before covered repairs are performed.

4. OTHER TERMS OF YOUR WARRANTIES

4.1 EXCHANGED PARTS MAY BE USED IN WARRANTY REPAIRS

In the interest of customer satisfaction, FCA US LLC may offer exchange service on some vehicle parts. This service is intended to reduce the amount of time your vehicle is not available for your use because of repairs. Parts used in exchange service may be new, remanufactured, reconditioned, or repaired, depending on the part involved.

All exchange parts that might be used meet FCA US LLC standards, and have the same warranties as new parts.

Examples of the kinds of parts that might be serviced in this way are:

- Engine Assemblies
- Transmission Assemblies
- Instrument Cluster Assemblies
- Radios, CD and DVD players
- Speedometers
- Powertrain Control Module (PCM)

To help control suspected ozone-depleting agents, the Environmental Protection Agency (EPA) requires the capture, purification, and reuse of automotive air conditioning refrigerant gases. As a result, a repair to the sealed portion of your air conditioning system may involve the installation of purified reclaimed refrigerant.

4.2 PRE-DELIVERY SERVICE

A defect in or damage to the mechanical, electrical, sheet metal, paint, trim, and other components of your vehicle may have occurred at the factory or while it was being shipped to an authorized dealer.

Such a defect or damage is usually detected and corrected at the factory. In addition, dealers must inspect each vehicle before delivery. The dealer will repair any defects or damage detected before the vehicle is delivered to you.

4.3 PRODUCTION CHANGES

Changes may be made in vehicles sold by FCA US LLC and its authorized dealers at any time without incurring any obligation to make the same or similar changes on vehicles previously built or sold.

5. FEDERAL EMISSION WARRANTY

5.1 PARTS COVERED FOR TWO YEARS OR 24,000 MILES

If your vehicle is equipped, federal law requires FCA US LLC to warrant the following emissions parts for two years or 24,000 miles, whichever occurs first. FCA US LLC covers all of these parts under the Basic Limited Warranty for three years or 36,000 miles, whichever occurs first.

For hybrid vehicles FCA US LLC covers these parts under the FCA US LLC Limited Emissions Warranty for eight years or 100,000 miles, whichever occurs first.

- Air system controls
- Electronic fuel injection system, including injector
- Evaporative emission canister and controls
- Exhaust manifold
- Exhaust Gas Recirculation (EGR) valve and control system
- Exhaust pipes (between exhaust manifold and catalyst)
- Fuel cap and tank assembly, pump, and fuel lines
- Hybrid Charging System – PHEV
- Hybrid Electric Cooling System – PHEV
- Hybrid Power Inverter System – PHEV
- Ignition system
- Intake manifold
- On-board diagnostic-system components
- Oxygen sensors
- Positive Crankcase Ventilation (PCV) valve or orifice

- Secondary ignition wires
- Spark Plugs
- Throttle Body
- Vacuum hoses, clamps, and fittings, as well as tubing used for these components
- Vacuum, temperature, altitude, speed, and time-sensitive valves, sensors, and switches used in these components and systems

5.2 PARTS COVERED FOR EIGHT YEARS OR 80,000 MILES

If your vehicle is equipped with one of the following parts, this Federal Emission Warranty covers that part for a period of eight years or 80,000 miles, whichever occurs first, calculated from the start of the Basic Limited Warranty as set forth in “section 2.1 E”. For PHEV vehicles, FCA US LLC covers all these parts under the FCA US LLC Limited Emission Warranty for eight years or 100,000 miles, whichever occurs first.

- Catalytic Converter
- Electric Brake Booster Control Module – PHEV
- Hybrid Control Processor (HCP) – PHEV
- Integrated DC-DC Charging Module – PHEV
- Motor Generator Unit – PHEV
- On-Board Charging Module – PHEV
- Power Pack Unit - Battery Pack Control Module – PHEV
- Powertrain Control Module (PCM)
- Transmission Control Module (TCM)

5.3 EMISSION PERFORMANCE WARRANTY

This Emission Performance Warranty supplements the Federal Emission Warranty under "section 5.1". It lasts for two years or 24,000 miles on the odometer, whichever occurs first. If your vehicle has one of the parts listed in "section 5.2", the Federal Emission Warranty covers that part for a period of eight years or 80,000 miles, whichever occurs first. For PHEV vehicles, FCA US LLC covers all these parts under the FCA US LLC Limited Emission Warranty for eight years or 100,000 miles, whichever occurs first. These limits are counted from the time when your Basic Limited Warranty begins, described in "section 2.1 E". The Emission Performance Warranty covers the cost of repairing or adjusting any components or parts that might be needed for your vehicle to pass federal emission standards for a federally approved state or local emission test, but only if:

- Your vehicle has failed a federally approved state or local emission test.
- Your vehicle has been maintained and operated properly up until it fails such a test.
- You face a real penalty, for example, a fine or the loss of the use of your vehicle because the vehicle has failed the test.

Refer to "section 6.6", Getting Service Under The Federal Emission Performance Warranties, for further information on how to get service under this warranty.

5.4 CALIFORNIA EMISSION WARRANTY

A. YOUR WARRANTY RIGHTS AND OBLIGATIONS APPLIES ONLY TO VEHICLES CERTIFIED FOR SALE AND REGISTERED IN THE STATE OF CALIFORNIA OR A STATE THAT HAS ADOPTED CALIFORNIA REGULATIONS

The California Air Resources Board is pleased to explain the emission control system warranty on your 2024 model vehicle. In California, new motor vehicles must be designed, built and equipped to meet the state's stringent anti-smog standards. FCA US LLC ("FCA US") must warrant the emission control system on your vehicle for the periods of time listed in this booklet provided there has been no abuse, neglect or improper maintenance of your vehicle.

Your emission control system may include parts such as the catalytic converter or Powertrain Control Module (PCM). Also included may be hoses, belts, connectors and other emission-related assemblies.

Where a warrantable condition exists, FCA US LLC will repair your vehicle at no cost to you, including diagnosis, parts and labor.

Some or all of your warranty rights and obligations can be found in the Warranty Information book at www.mopar.com.

The emission warranty statement specified in this booklet applies only to vehicles certified for sale and registered in the state of California or in one of the following states:

Colorado	Massachusetts	Pennsylvania
Connecticut	New Jersey	Rhode Island
Delaware	New York	Vermont
Maine	Oregon	Washington
Maryland		

In addition, if your vehicle is a model certified as a Transitional Zero Emission Vehicle (TZEV), you are entitled to the warranty rights and obligations set forth in this booklet, if your vehicle was certified for sale and registered in California or one of the following states:

Colorado	Massachusetts	Oregon
Connecticut	New Jersey	Rhode Island
Maine	New York	Vermont
Maryland		

B. OWNER’S WARRANTY RESPONSIBILITIES

- As the vehicle owner, you are responsible for the performance of the required maintenance listed in your Owner’s Manual. FCA US LLC recommends that you retain all receipts covering maintenance on your vehicle, but FCA US LLC cannot deny warranty solely for the lack of receipts or for your failure to ensure the performance of all scheduled maintenance.
- You are responsible for presenting your vehicle to any authorized Chrysler, Dodge, Jeep® or Ram dealer as soon as a problem exists. The warranty repairs should be completed in a reasonable amount of time, not to exceed 30 days.

- As the vehicle owner, be aware that FCA US LLC may deny your warranty coverage if your vehicle or a part has failed due to abuse, neglect, improper maintenance or unapproved modifications.

C. GETTING SERVICE UNDER THE CALIFORNIA EMISSION WARRANTY

What To Do If You Fail A Smog Check

If a vehicle fails a state smog check test during the coverage period, FCA US LLC will repair the vehicle so that it will pass a state smog check retest. The owner should take the vehicle to any authorized Chrysler, Dodge, Jeep® or Ram dealer for warranty repairs and give a copy of the failed smog check test report to the dealer. If the owner is not notified within 30 days that a performance warranty claim is denied, the manufacturer must repair the vehicle free of charge.

What To Do To Get Warranty Service

To get warranty service, even if you are traveling, take your vehicle to any authorized Chrysler, Dodge, Jeep® or Ram dealer. FCA US LLC recommends that you take your vehicle to an authorized dealer who sells the same make of vehicle as yours. That dealer will perform any warranty service without charging you for diagnosis, parts or labor.

Emergency Emission Warranty Service

If you need emergency service under this warranty and an authorized Chrysler, Dodge, Jeep® or Ram dealer is not readily available, you may have your vehicle repaired by anyone using any brand of repair parts.

Before FCA US LLC will reimburse you for emergency repairs under this warranty, you will have to provide FCA US LLC with details on why the situation was an emergency and why dealer service was unavailable.

Under this warranty, an emergency occurs if a part will not be available within 30 days or if a repair cannot be completed within 30 days.

However, FCA US LLC recommends that you do the following before having repairs made:

- Contact the FCA US LLC Customer Assistance Center and ask for help with emission warranty service.
- The Customer Assistance Center will recommend an authorized servicing dealer or help you find a qualified independent servicing dealer.
- If you need to use an independent servicing dealer, make arrangements during your first contact with the Customer Assistance Center for reimbursement for emergency repairs (including labor and diagnosis). You will need to get and keep the replaced parts, as well as the original invoice marked "paid".
- Review with the Customer Assistance Center any questions you have about the emission warranty. Reimbursement for parts will be based on FCA US LLC's suggested retail price. Reimbursement for labor will be based on FCA US LLC's recommended time allowance for the repair and on the appropriate hourly labor rate in the geographic area where you have the work done.

How To Get More Information

For more information or questions about the California Emission Warranty, contact one of the following:

FCA US LLC Customer Assistance Center

800-423-6343

P.O. Box 21-8004

Auburn Hills, MI 48321-8004

California Air Resources Board

4001 Iowa Ave.

Riverside, CA 92507

Use this QR code to download the most up-to-date Warranty Book.



D. MANUFACTURER'S WARRANTY COVERAGE

Parts And Performance Covered For Three Years Or 50,000 Miles, Whichever Occurs First

If your vehicle fails a smog check inspection, all necessary repairs and adjustments will be made by FCA US LLC to ensure that your vehicle passes the inspection. This is your emission control system PERFORMANCE WARRANTY.

If any emission-related part on your vehicle is defective, the part will be repaired or replaced by FCA US LLC. This is your short-term emission control system DEFECTS WARRANTY.

California law requires FCA US LLC to warrant that if any emission-related part on your vehicle is defective, FCA US LLC will repair or replace the part. The repair or replacement will be made at no cost

to you for diagnosis, parts or labor. Any other parts damaged by the failure of a defective part will also be repaired or replaced.

Your emission control system may include parts such as the catalytic converter or Powertrain Control Module (PCM). Also included may be hoses, belts, connectors and other emission-related assemblies.

The full list of parts is available in the Basic Limited Warranty book on www.mopar.com.

Parts Covered For Seven Years Or 70,000 Miles, Whichever Occurs First

If an emission-related part listed in this warranty booklet specially noted with coverage for seven years or 70,000 miles is defective, the part will be repaired or replaced by FCA US LLC. This is your long-term emission control system DEFECTS WARRANTY.

FCA US LLC also warrants that every part listed, if installed as original equipment, is free from defects. The full list of parts is available in the Basic Limited Warranty book on www.mopar.com.

Where parts are scheduled for replacement as required maintenance, this warranty applies until the first scheduled maintenance point listed in the Owner's Manual.

These parts are:

- Camshaft
- Crankshaft Target Wheel
- Cylinder Head Assembly for Valve Guide/Valve Seat Replacement
- Cylinder Head Gasket
- Exhaust Gas Recirculation (EGR) Cooler

- Instrument Cluster – Check Engine/Malfunction Indicator Light (MIL) and Associated Circuits Replacement
- Intake/Exhaust Valve
- Piston
- Piston Rings
- Plastic Fuel Tank Assembly
- Proportional Purge Solenoid (PPS)
- Transmission Valve Body
- Valve Stem Oil Seals

Coverage For 15 Years Or 150,000 Miles, Whichever Occurs First

If your vehicle is certified as a Transitional Zero Emission Vehicle (TZEV) and is sold, registered and operated in California, the California Emission, Performance and Defects warranties for emission-related parts is 15 years or 150,000 miles, whichever occurs first.

The High Voltage Lithium-Ion Battery Limited Warranty coverage is 10 years or 150,000 miles, whichever occurs first.

6. WHERE TO TAKE YOUR VEHICLE

6.1 IN THE UNITED STATES AND US POSSESSIONS AND TERRITORIES FOR WARRANTY PURPOSES

Warranty service must be done by an authorized Chrysler, Dodge, Jeep®, or Ram dealer. We strongly recommend that you take your vehicle to your selling dealer. They know your vehicle best, and are most concerned that you get prompt and high quality service. If you move within the United States, warranty service may be requested from any authorized Chrysler, Dodge, Jeep®, or Ram dealer.

6.2 IN CANADA AND MEXICO

If you are traveling temporarily in Canada or Mexico, and your vehicle remains registered in the United States, your FCA US LLC warranty still applies. Service may be requested at any authorized Chrysler, Dodge, Jeep®, or Ram dealer.

6.3 IN A FOREIGN COUNTRY OUTSIDE OF NORTH AMERICA

If you are traveling temporarily outside of North America, and your vehicle remains registered in the United States:

- Take your vehicle to an authorized Chrysler, Dodge, Jeep®, or Ram dealer. They should give you the same warranty service you receive in the United States.
- If the authorized dealer charges you for repairs which you feel should be covered under your warranty, please get a detailed receipt for the work done. Make sure that this receipt lists all warranty repairs and parts that were involved. This receipt will be similar to the one used by the authorized dealer that normally services your vehicle.
- When your vehicle returns to the United States, contact the FCA US LLC Customer Assistance Center for reimbursement consideration. You can find the address in “section 7.2”. You will normally need to provide a copy of the receipt, your vehicle registration and any other relevant documents.
- Reimbursement will not be considered if the vehicle does not return to the United States.

6.4 HOW TO GET ROADSIDE ASSISTANCE SERVICE — U.S. OR CANADA ONLY *

A. WHO IS COVERED

You are covered by Roadside Assistance services if you are a purchaser for use of the vehicle. Roadside Assistance coverage is

calculated from the start date of the Basic Limited Warranty, as set forth in "section 2.1 E".*

Roadside Assistance services last for five years or 60,000 miles on the odometer, whichever occurs first. Pacifica Hybrid Electric Vehicles that cannot be driven due to failure of a part covered by the High Voltage Battery Limited Warranty will be eligible for standard towing coverage up to the applicable terms defined in "section 2.4 D". If your vehicle is covered under the California Emission Warranty, additional terms may apply. Please refer to the California Emissions Warranty booklet for additional information.

B. WHAT TO DO

If your vehicle requires jump start assistance, out of gas/fuel delivery, tire service, lockout service or towing as a result of a mechanical breakdown, call 800-521-2779 or go to www.chrysler.rsahelp.com for assistance.

Provide your name, Vehicle Identification Number (VIN) — required for covered services, license plate number, and your location, including the telephone number from which you are calling. Briefly describe the nature of the problem and answer a few simple questions.

You will be given the name of the service provider and an estimated time of arrival. If you feel you are in an "unsafe situation", please let us know. With your consent, we will contact local police or safety authorities.

C. IF UNABLE TO CONTACT ROADSIDE ASSISTANCE

If you are unable to contact Roadside Assistance or unable to provide a valid Vehicle Identification Number (VIN) and you obtain towing services on your own, you may submit your original receipts from the licensed towing or service facility for services rendered within 30 days of the occurrence. Be sure to include your VIN, odometer mileage at the time of service and current mailing address. We will process the claim based on vehicle and service eligibility. If eligible, we will reimburse you for the reasonable amounts you actually paid, based on the usual and customary charges for that service in the area where they were provided. FCA US LLC's determination relating to reimbursement is final. Correspondence should be mailed to:

FCA US LLC Customer Assistance

P.O. Box 9145

Medford, MA 02155

Attention: Claims Department

FCA US LLC reserves the right to modify the terms or to discontinue the Roadside Assistance Program at any time. The Roadside Assistance Program is subject to restrictions and conditions of use, that which are determined solely by FCA US LLC.

* Roadside Assistance services provided through Cross Country Motor Club, Inc., 400 River's Edge Drive, Medford, MA 02155, except in AK, CA, HI, OR, WI, and WY, where services are provided by Cross Country Motor Club of California, Inc., 275 East Hillcrest Drive, Suite 165, Thousand Oaks, CA 91360.

D. COVERED SERVICES

Flat Tire Service

If you are inconvenienced by a flat tire, we will dispatch a service provider to use your vehicle's temporary spare tire (if equipped) as recommended in your Owner's Manual. This is not a permanent flat tire repair.

Out of Gas/Fuel Delivery

Drivers cannot always count on a gas station being nearby, especially when traveling away from home. We will dispatch a service provider to deliver a small amount of fuel (maximum two gallons) to get you to a nearby station. This service is limited to two occurrences in a 12-month period.

Battery Jump Assistance

No time is a good time for a depleted battery, but with Roadside Assistance, you do not have to worry about being stranded. We will dispatch a service provider to provide you with a battery jump any time, day or night.

Lockout Service

Whether the keys are locked in your vehicle or frozen locks are keeping you from getting on your way, Roadside Assistance can assist you. This service is limited to providing access to the vehicle's seating area. It does not cover the cost of replacement keys.

Towing Service

Roadside Assistance service gives you peace of mind and confidence. If your vehicle becomes disabled as a result of a mechanical breakdown, Roadside Assistance will dispatch a towing service provider to transport your vehicle to the closest authorized Chrysler, Dodge, Jeep®, or Ram dealer. If you choose to go to another dealer, you will be responsible for the cost of the additional mileage.

6.5 EMERGENCY WARRANTY REPAIRS

If you have an emergency and have to get a warranty repair made by someone other than an authorized Chrysler, Dodge, Jeep®, or Ram follow the reimbursement procedure in "section 6.4 C".

6.6 GETTING SERVICE UNDER THE FEDERAL EMISSION PERFORMANCE WARRANTIES

A. WHAT TO DO

If the vehicle has failed an emissions test described in "section 5.3":

- Take the vehicle to an authorized Chrysler, Dodge, Jeep® or Ram dealer as soon as possible.
- Give the service representative the printout showing that the vehicle failed the test.
- If possible, bring all service receipts, maintenance logs, and records proving that the vehicle has been properly maintained, since you may be required to show them.

B. FURTHER STEPS YOU CAN TAKE, AND HOW TO GET MORE INFORMATION

If you think an authorized dealer has wrongly denied you emission warranty coverage, follow the recommended instructions described in "section 7.1". FCA US LLC will reply to you in writing within 30 days after receiving your complaint (or within the time limit required by local or state law). If the owner is not notified within 30 days that a performance warranty claim is denied, the manufacturer must repair the vehicle free of charge.

For more information about getting service under the Federal Emission Warranty or the Performance Warranty, or to report what you think is a violation of these warranties, contact:

Manager, Certification and Compliance

Division Warranty Claims

Environmental Protection Agency

1200 Pennsylvania Avenue, NW

Mail Code 6403J

Washington, D.C. 20460

7. HOW TO DEAL WITH WARRANTY PROBLEMS

7.1 STEPS TO TAKE

A. IN GENERAL

Normally, warranty problems can be resolved by an authorized dealer's sales or service departments. Always talk to the authorized dealer's service manager or sales manager first. If you are not satisfied with the authorized dealer's response to your problem, FCA US LLC recommends that you discuss your problem with the owner or general manager of the authorized dealer.

If the authorized dealer still cannot resolve the problem, contact the FCA US LLC Customer Assistance Center. You can find the address in "section 7.2".

B. WHAT FCA US LLC WILL DO

Once you have followed the recommended instructions described in "section 7.1 A", a FCA US LLC representative at FCA US LLC headquarters will review your situation. If it is something that FCA US LLC can help you with, FCA US LLC will provide an authorized dealer with all the information and assistance necessary to resolve the problem. Even if FCA US LLC cannot help you, FCA US LLC will acknowledge your contact and explain FCA US LLC's position.

If you cannot resolve your warranty problem after following the recommended instructions described in "section 7.1 A", you may

obtain a brochure describing FCA US LLC's Customer Arbitration Process (CAP), including an application, by calling 800-247-9735 for assistance. For further details on resolving your warranty problem, please see the Lemon Law booklet available online at www.mopar.com.

C. VOLUNTARY NON-BINDING ARBITRATION PROCESS

FCA US LLC offers a non-binding voluntary dispute resolution process in all 50 states, which is administered by the National Center for Dispute Settlement (NCDS).

This service is strictly voluntary, and you may submit your dispute directly to the CAP at no cost. The CAP is administered by an independent dispute settlement organization and may be contacted in writing at the following address:

National Center for Dispute Settlement (NCDS)

FCA US LLC Customer Arbitration Process

P.O. Box 515315

Dallas, TX 75251-5315

The CAP reviews only vehicle disputes involving FCA US LLC ("FCA US") Limited Warranty or an FCA US LLC/Mopar® Part Limited Warranty. The CAP does not review disputes involving the sale of a new or used vehicle, personal injury/property damage claims, disputes relating to the design of the vehicle or a part, or disputes which are already the subject of litigation.

The CAP will need the following information from you:

1. Legible copies of all documents and repair orders relevant to your case.
2. Vehicle Identification Number (VIN) of your vehicle.
3. A brief description of your unresolved concern.
4. The identity of your servicing/selling dealer.
5. The date(s) of repair(s) and mileage at the time.
6. The current mileage.
7. A description of the action you expect to resolve your concern.

Upon receipt of your request:

- The National Center for Dispute Settlement (NCDS) will acknowledge receipt of your request, by email or mail, within 10 days, and advise you whether or not your dispute is within the jurisdiction of the process.
- When your request is within jurisdiction, NCDS will request FCA US LLC to present their side of the dispute. You will receive copies of the responses.
- While your dispute is pending, NCDS or FCA US LLC may contact you to see if your case can be settled by agreement. If a settlement is offered to you, FCA US LLC will ask you to sign a form that contains that settlement. Your case will then be closed. There is no requirement for you to participate in this settlement process.
- If you requested an oral hearing, with NCDS will contact you to arrange a convenient time and place for a hearing. Usually, this will be at a dealer near you or by teleconference.

- If you request a documents-only review, a panel of neutral arbitrators will review and decide your case. Neither you nor FCA US LLC need be present.
- NCDS will send you a written Statement of Decision. This statement will include the decision, any action to be taken by FCA US LLC and the time by which the action must be taken. The decision will be binding on FCA US LLC but not on you unless you accept the decision.
- If any action is required on FCA US LLC, you will be contacted within 10 days after the date by which FCA US LLC must act to determine whether performance has been rendered.
- The entire dispute settlement process will normally take no longer than 40 days.

D. NOTICE UNDER STATE LEMON LAWS

Some states have laws allowing you to get a replacement vehicle or a refund of the vehicle's purchase price under certain circumstances. These laws vary from state to state. If your state law allows, FCA US LLC requires that you first notify us in writing of any service difficulty that you may have experienced so that we can have a chance to make any needed repairs before you are eligible for remedies provided by these laws. In all other states, we ask that you give us written notice of any service difficulty. Send your written notice to the FCA US LLC Customer Assistance Center using the address in "section 7.2".

E. CALIFORNIA RESIDENTS ONLY

FCA US LLC offers a non-binding dispute resolution program in the state of California that has been certified by the Arbitration Certification Program of the state. The California Dispute Settlement

Program (CDSP) is a neutral third-party arbitration provider that administers the cases. Detailed program information can be found online at www.mopar.com under Warranty/Additional Publications or in the California Dispute Settlement Program booklet provided with your vehicle.

7.2 HELPFUL ADDRESSES AND TELEPHONE NUMBERS

Here are the addresses and telephone numbers of the FCA US LLC Customer Assistance Centers that can help you wherever you happen to be. Contact the one that covers your area:

- **In the United States:**

FCA US LLC Customer Assistance Center

P.O. Box 21-8004

Auburn Hills, Michigan 48321-8004 To

contact FCA US LLC by email: Select the

“Contact Us” button on

www.chrysler.com

Phone Number: 800-247-9753

- **In Canada:**

FCA Canada Customer Care

Chrysler Centre

P.O. Box 1621

Windsor, Ontario N9A-4H6

Phone Number (English): 800-465-2001

Phone Number (French): 800-387-9983

- **In Mexico:**

Customer Relations Office

Prolongación Paseo de la Reforma 1240

Santa Fe, C.P. 05109

México, CDMX

Phone Number (in Mexico): 800-505-1300

Phone Number (outside Mexico): +(52) 55 50817568

- **In Puerto Rico and U.S. Virgin Islands:**

FCA Caribbean LLC Customer Service

P.O. Box 191857

San Juan, Puerto Rico 00919-1857

Phone Number: 800-423-6343

8. OPTIONAL SERVICE CONTRACT

Mopar® Vehicle Protection plans offer valuable protection against repair costs when these warranties no longer apply. They complement but do not replace the warranty coverages outlined in this booklet. A variety of plans are available, covering various time-and-mileage periods and various groups of the vehicle's mechanical components.

Mopar® Vehicle Protection plans are the **ONLY** vehicle extended protection plans authorized, endorsed and backed by FCA US LLC to provide additional protection beyond your vehicle's warranty. Look for our brand logo and ask an authorized dealer for details or contact Mopar Vehicle Protection at: 1-800-521-9922.



**VEHICLE
PROTECTION**

A PRODUCT OF FCA US LLC

Original Owner's Name

Street Address

City and State Zip Code

Vehicle Identification Number

Warranty Start Date (In-Service Date) Mileage at Delivery

Selling Dealer Code

City State

Second Owner's Name

Street Address

City and State Zip Code

Date of Second Purchase Mileage at Purchase

Third Owner's Name

Street Address

City and State Zip Code

Date of Third Purchase Mileage at Purchase

Warranty coverage applies to all vehicle owners. To protect you in the event of a recall or any questions concerning your warranty, please tell your dealer about any ownership or address change, and write the details here.

For the most up-to-date warranty information go to Mopar.com



9. MAINTENANCE

9.1 GENERAL INFORMATION

It is your responsibility to properly maintain and operate your new vehicle. Follow the instructions contained in the General and Scheduled Maintenance Service guidelines in your Owner's Manual. Regular, scheduled maintenance is essential to trouble-free operation. If there is a dispute between you and FCA US LLC concerning the maintenance of your vehicle, FCA US LLC will require you to provide proof that your vehicle was properly maintained.

For your convenience, FCA US LLC has prepared a Maintenance Schedule with routine service intervals which is included in your Owner's Manual. It is essential to follow these required maintenance intervals for safe trouble-free operation.

9.2 WHERE TO GO FOR MAINTENANCE

FCA US LLC recommends that you return to the authorized dealer from whom you bought your vehicle for all maintenance service both during and after the warranty periods. Although you can get warranty service from any authorized dealer who sells your particular make, returning to your selling authorized dealer will help ensure that all your service needs are met and that you are completely satisfied. The dealer technicians are specifically trained to proficiently perform maintenance and repair procedures on your vehicle.

Authorized Chrysler, Dodge, Jeep®, or Ram dealers will help ensure that all your service needs are met and that you are completely satisfied. FCA US LLC strongly recommends you use genuine FCA US LLC/Mopar® parts to maintain your vehicle.



VX5AI MDVR

Vulcan™ Series VX5AI MDVR

The five-channel VX5AI is ideal for smaller buses and transport vans and records up to five camera views: four HD channels at D1, 720P or 1080P—plus one IP channel at up to 1080P resolution, for a key location where IP clarity is needed most. Video is stored on a locking hard drive, with a microSD card slot for redundancy.

- 5-channel system
- 4 channels D1, 720P, or up to 1080P + 1 channel IP up to 1080P
- 1TB (standard) 2.5" SATA or solid-state drive, up to 2TB
- microSD card slot for redundant recording
- Five (5) year limited warranty

[Download Tech Specs](#)

CAMERAS

The VX5AI MDVR is compatible with Vulcan™ Series HD cameras, MDVR-compatible IP cameras and MDVR-compatible accessories.



WARRANTY

We stand behind the Vulcan™ Series mobile DVR by offering a five-year, limited parts and labor warranty that is unmatched in the industry, and from first contact to warranty fulfillment, AngelTrax provides unparalleled customer service and support.



DRIVER-OPERATED PANIC BUTTON

Alerts, triggered by the driver-operated panic button or one of eight configurable alarms, automatically mark video for supervisor review during playback. The panic button, included with every Vulcan Series MDVR and installed within easy reach on the driver's console, is an inconspicuous tool the driver can use to mark the video at the time and date of an incident occurring on the vehicle. The panic button also functions as a remote status indicator for the MDVR. A solid green LED indicates the unit has power and is recording without using a video monitor.

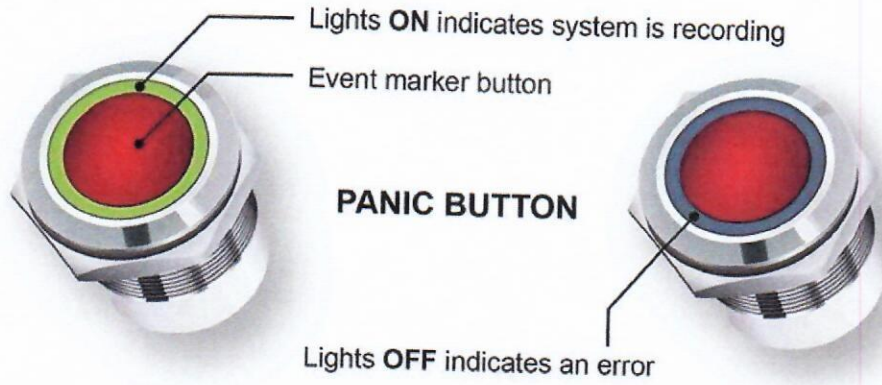

Exceptional »

CUSTOMER SERVICE



PRODUCT TRAINING



TECHNICAL SUPPORT



Contact Us

1.800.673.1788 (Toll-free)
1.334.692.4600 (Local)
1.334.692.4606 (Fax)

[Email Tech Support](#)

Location

119 South Woodburn Drive
Dothan, AL 36305

[Careers](#)

Follow Us



[Privacy Policy](#) | [Terms of Use](#) | [Disclaimer](#) | [Cookie Policy](#)

Copyright © 2022 IVS, Inc. dba AngelTrax. All rights reserved.



HD-V CAMERAS

VULCAN™ SERIES HD-V CAMERAS

- 1080P
- Super Infrared
- Fully articulated lens casing



Interior or Exterior

The versatile, low profile HD-V camera from AngelTrax features a fully articulated lens casing that is adjustable vertically, horizontally and 180 degrees in any direction to obtain the desired view of the vehicle's interior or exterior and surroundings.

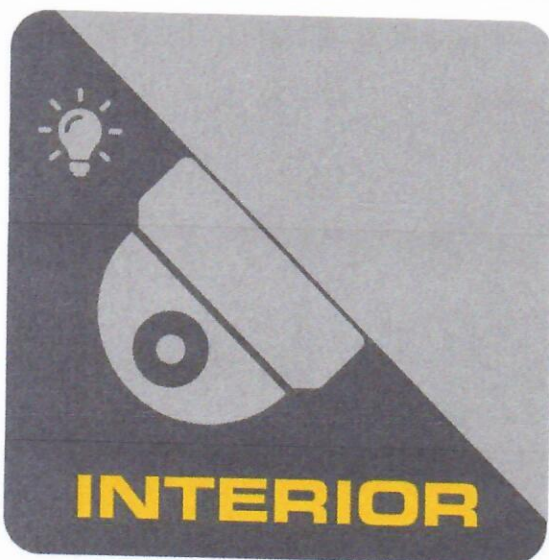

Super Infrared

Equipped with Super Infrared, automated white balance and digital noise reduction, the HD-V camera is capable of capturing

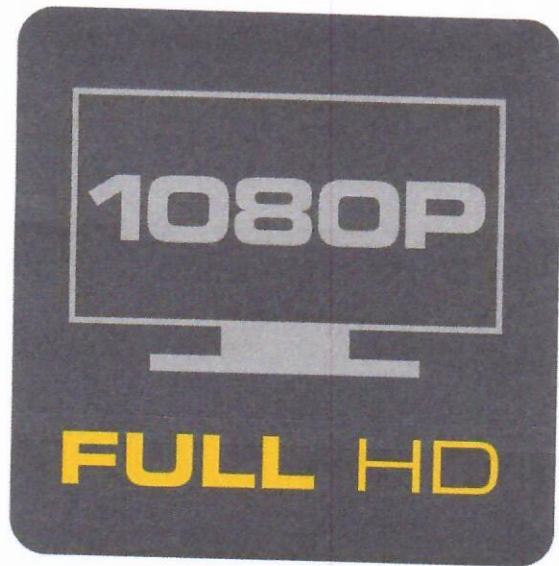
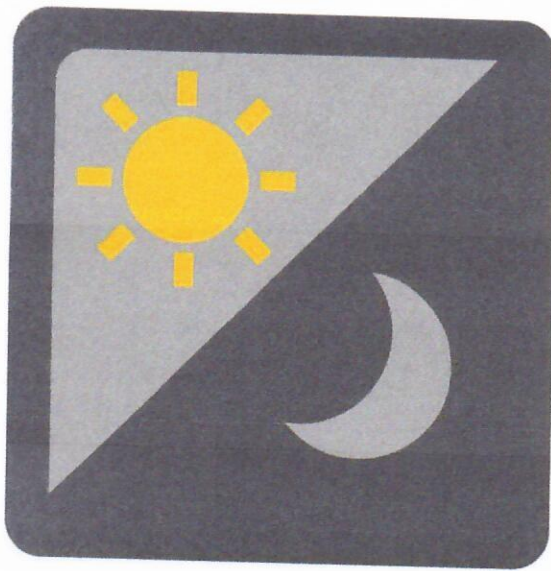

HD1700V

- 1.7mm Extreme Wide Angle
- Shorter Focal Length
- 170° Horizontal Field of View
- 90° Vertical Field of View

[Download Tech Specs](#)

HD2100V

- 2.1mm
Wide Angle
- Shorter Focal Length
- 125° Horizontal Field of View

[Download Tech Specs](#)

HD2500V

- 2.5mm
Wide Angle
- Shorter Focal Length
- 110° Horizontal Field of View

[Download Tech Specs](#)

HD3600V

- 3.6mm
Wide Angle
- Medium Focal Length
- 70° Horizontal Field of View

[Download Tech Specs](#)

HD6000V

- Deeper Focal Length
- 52° Horizontal Field of View

[Download Tech Specs](#)

Live View & Live Tracking



« with PRO8 CMS

Contact Us

1.800.673.1788 (Toll-free)

1.334.692.4600 (Local)

1.334.692.4606 (Fax)

[Email Tech Support](#)

Location

119 South Woodburn Drive

Dothan, AL 36305

[Careers](#)

Follow Us



[Privacy Policy](#) | [Terms of Use](#) | [Disclaimer](#) | [Cookie Policy](#)

Copyright © 2022 IVS, Inc. dba AngelTrax. All rights reserved.

FEDERAL TRANSIT BUS TEST

**Performed for the Federal Transit Administration U.S. DOT
In accordance with 49 CFR, Part 665**

Manufacturer: BraunAbility / The Braun Corporation

**Model: Chrysler Pacifica / Voyager Commercial
Wheelchair Accessible Vehicle
w/ Side-Entry Manual Foldout Ramp**

**Tested in Service-Life Category
4 Year / 100,000 Miles**

November 2020

Report Number: LTI-BT-R2020-03

**The Thomas D. Larson
Pennsylvania Transportation Institute
201 Transportation Research Building
The Pennsylvania State University
University Park, PA 16802
(814) 865-1891**

**Bus Testing and Research Center
2237 Plank Road
Duncansville, PA 16635
(814) 695-3404**



PennState
College of Engineering

**LTI BUS RESEARCH
AND TESTING CENTER**

FEDERAL TRANSIT BUS TEST

Performed for the Federal Transit Administration, U.S. DOT
1200 New Jersey Avenue, SE
Washington, DC 20590

In accordance with 49 CFR Part, 665

Manufacturer: BraunAbility / The Braun Corporation
Manufacturer's address: 631 W. 11th Street
Winamac, IN 46996

Model: Chrysler Pacifica / Voyager Commercial
Wheelchair Accessible Vehicle w/Side-Entry
Manual Foldout Ramp

Tested in Service-Life Category
4 Year / 100,000 Miles

Report Number: LTI-BT-R2020-03



David Klinikowski

Quality Authorization

Director, Bus Research
and Testing Center

Title

November 20th 2020

Date

TABLE OF CONTENTS

	<u>Page</u>
EXECUTIVE SUMMARY	4
ABBREVIATIONS AND ACRONYMS	7
BUS CHECK-IN	8
1. MAINTAINABILITY	
1.1 ACCESSIBILITY OF COMPONENTS AND SUBSYSTEMS	23
1.2 SERVICING, PREVENTIVE MAINTENANCE, AND REPAIR AND MAINTENANCE DURING TESTING	26
1.3 REPLACEMENT AND/OR REPAIR OF SELECTED SUBSYSTEMS	29
2. RELIABILITY	32
3. SAFETY	
3.1 DOUBLE-LANE CHANGE (OBSTACLE AVOIDANCE TEST)	34
3.2 BUS BRAKING PERFORMANCE TEST	38
4. PERFORMANCE	43
5. STRUCTURAL INTEGRITY	
5.1 STRUCTURAL SHAKEDOWN – DISCONTINUED TEST	
5.2 STRUCTURAL STRENGTH AND DISTORTION TESTS - STRUCTURAL DISTORTION	47
5.3 STRUCTURAL STRENGTH AND DISTORTION TESTS - STATIC TOWING	59
5.4 STRUCTURAL STRENGTH AND DISTORTION TESTS - DYNAMIC TOWING	60
5.5 STRUCTURAL STRENGTH AND DISTORTION TESTS- JACKING	63
5.6 STRUCTURAL STRENGTH AND DISTORTION TESTS- HOISTING.....	66
5.7 STRUCTURAL DURABILITY	69
6. FUEL ECONOMY	77
7. NOISE	
7.1 INTERIOR NOISE AND VIBRATION TESTS	85
7.2 EXTERIOR NOISE TESTS	90
8. EMISSIONS	96

EXECUTIVE SUMMARY

TEST HIGHLIGHTS

The information in this report pertains only to this specific bus, as received from the manufacturer for testing.

The Check-In section of the report provides a description of the bus and specifies its major components. The following table gives the salient specifications.

Manufacturer	BraunAbility / The Braun Corporation
Model	Chrysler Pacifica / Voyager Commercial Wheelchair Accessible Vehicle w/Side-Entry Manual Foldout Ramp
Chassis Make/Model	Chrysler Pacifica / Voyager
Chassis Modified	Yes
Length	16 feet, 8 ½ inches
Fuel	Gasoline
Service Life	4 Years / 100,000 miles
Number of Seats (including driver)	5 and 1 wheelchair
Manufacturer-Designated Standing Passenger Capacity	No standing passengers
Gross Vehicle Weight used for testing	5,830 lb.
Gross Vehicle Weight Rating	6,055 lb.
Mileage at Delivery	37
Test Start Date	March 19, 2020
Test Completion Date	October 07, 2020

The measured curb weight was 2,520 lb. for the front axle and 1,940 lb. for the rear axle. These combined weights provided a total measured curb weight of 4,460 lb. There are 5 seats including the driver and one wheelchair position. Since this vehicle is a minivan, it is not possible to accommodate standing passengers. Therefore, the gross load represents seated passengers only, for a total of 6 passengers. Gross load is calculated as $(150 \text{ lb.} \times 5) + (600 \text{ lb.} \times 1) = 1,350 \text{ lb.}$ At full declared capacity, the measured gross vehicle weight was 5,830 lb.

BUS TESTING BACKGROUND

On August 1, 2016, FTA announced a final rule for bus testing for improving the process of ensuring the safety and reliability of new transit buses. The rule satisfies requirements in MAP-21 to establish minimum performance standards, a standardized scoring system, and a pass-fail threshold based on the score.

FTA's Bus Testing Program (often referred to as "Altoona Testing" due to the location of the main testing center) tests new transit bus models for:

- Maintainability
- Reliability

- Safety
- Performance (including Braking Performance)
- Structural Integrity (including Structural Durability)
- Fuel Economy (Energy Efficiency and Range, for electric buses)
- Noise
- Emissions

Bus models that fail to meet one or more minimum performance standards will “fail” their test and thus be ineligible for purchase with FTA funds until the failures are resolved and validated through further testing. FTA will use this authority to make sure defects are corrected before a bus model can be acquired with FTA funding.

In each application to FTA for the purchase or lease of any new bus model, or any bus model with a major change in configuration or components to be acquired or leased with funds obligated by the FTA, the recipient shall certify that it has received the appropriate full Bus Testing Report and any applicable partial testing report(s) before final acceptance of the first vehicle. In dealing with a bus manufacturer or dealer, the recipient shall be responsible for determining whether a vehicle to be acquired requires full testing or partial testing or has already satisfied the requirements of this part. A bus manufacturer or recipient may request guidance from FTA in making these determinations.

The purpose of the testing is intended set a “Pass/Fail” standard and grade the performance of the buses in order to provide performance information to the transit authorities that can be used in their purchase or lease decisions. The intent of this report is to provide the grantee a relative measure of the performance of a particular model of transit bus against a standard of performance. The passing of this test should ensure a vehicle has a high probability of meeting its service life in the category it was tested.

The data included in this test report and other applicable reports should be reviewed to choose the most suitable bus for a grantee’s operation. A higher scoring bus is not necessarily the best bus for a given application. For example, a bus with a powerful engine may score well because of its performance and gradeability, but another bus with a smaller and more fuel-efficient engine could be a better choice for applications in mostly flat areas. It is the responsibility of the grantee to ensure the proper test report or applicable partial report is in their possession and has been thoroughly reviewed.

The score sheet for the subject vehicle of this test report is provided below. **This bus passed the Altoona test, with an aggregate score of 92.5.**



Pre-Award Buy America Certification

Manufacturer: The Braun Corporation
Bid No.:
Description: Wheelchair Accesible Vehicle
End User: State of WV
VIN / Job: BA3363349
Final assembly activities completed at: The Braun Corporation
 631 W 11th St. Winamac, IN 46996

Component	Manufacturer	Country of Origin	C % of Total Cost
OEM Chassis	FCA Canada	Windsor, Ontario, Canada	39.552%
Weldment	The Braun Corporation	Winamac, IN, United States	11.350%
Sub Assembly	The Braun Corporation	Winamac, IN, United States	4.968%
Seats - Seating & Fabric	The Braun Corporation	Winamac, IN, United States	3.833%
ADA & Special Equip.	The Braun Corporation	Winamac, IN, United States	2.501%
Ramp Parts & Assemblies	The Braun Corporation	Winamac, IN, United States	2.194%
Plastic - Vacform & Inj.	The Braun Corporation	Winamac, IN, United States	1.386%
Wire / Harness / Loom	Altex	Westfield, IN, United States	1.235%
Floor - Substrate & Covering	Standard Integrated Solutions, Inc.	Winamac, IN, United States	0.909%
Plastic - Vacform & Inj.	Lippert Components Inc	Chicago, IL, United States	0.465%
Weldment	Standard Integrated Solutions, Inc.	Winamac, IN, United States	0.425%
Metal Fabrication	MORryde International, Inc.	Elkhart, IN, United States	0.365%
Plastic - Vacform & Inj.	Patrick Industries Inc	Elkart, IN, United States	0.304%
Heat, Ventilation, Air Cond.	Formfab LLC	Rochester Hills, MI, United States	0.302%
Electronics / Switches & Senso	FEV North America Inc.	Auburn Hills, MI, United States	0.278%
Metal Fabrication	The Braun Corporation	Winamac, IN, United States	0.254%
Metal Fabrication	LSI Metal Fabrication	Logansport, IN, United States	0.228%
Fuel system & Undercarriage	Formfab LLC	Rochester Hills, MI, United States	0.191%
Option-Vehicle	The Braun Corporation	Winamac, IN, United States	0.180%
Metal Fabrication	Cutting Edge Machine & Tool	New Paris, IN, United States	0.175%
Restraint Systems & Belts	The Braun Corporation	Winamac, IN, United States	0.148%
Metal Fabrication	Standard Integrated Solutions, Inc.	Winamac, IN, United States	0.078%
Brake System	Formfab LLC	Rochester Hills, MI, United States	0.069%
Metal Machined Parts	Cutting Edge Machine & Tool	New Paris, IN, United States	0.060%
Sub Assembly	Cutting Edge Machine & Tool	New Paris, IN, United States	0.053%
Fuel system & Undercarriage	Cooper-Standard Automotive Fhs, Inc.	Chicago, IL, United States	0.051%
ADA & Special Equip.	ACME United Corporation	Pittsburgh, PA, United States	0.051%
Wire / Harness / Loom	Atronix, Inc.	Tucson, AZ, United States	0.046%
Metal Fabrication	Quality Tool And Stamping, Inc.	Muskegon Heights, MI, United States	0.044%
Media / Decals / Literature	Sharpline Converting Inc.	Wichita, KS, United States	0.041%
Heat, Ventilation, Air Cond.	HS Automotive USA LLC	Enterprise, AL, United States	0.039%
Exhaust System & Components	Exhaust Productions Inc.	Merrillville, IN, United States	0.039%
Metal Fabrication	MJ Celco, Inc.	Schiller Park, IL, United States	0.035%
Metal Machined Parts	The Braun Corporation	Winamac, IN, United States	0.035%
Plastic - Vacform & Inj.	SPI Blow Molding LLC	Coloma, MI, United States	0.032%



ADA & Special Equip.	Cooper-Standard Automotive Fhs, Inc.	Chicago, IL, United States	0.030%
Plastic - Vacform & Inj.	Proto Shapes, Inc.	Coldwater, MI, United States	0.028%
Media / Decals / Literature	Mandala Screen Printing	Winamac, IN, United States	0.027%
Sub Assembly	Vista Manufacturing Inc	Elkhart, IN, United States	0.023%
Plastic - Vacform & Inj.	Thunderbird Molding Shelbyville	Columbus, OH, United States	0.018%
Metal Machined Parts	Kilgore Manufacturing Co. Inc.	Columbia City, IN, United States	0.017%
ADA & Special Equip.	Certified Safety Manufacturing, Inc.	Dallas, TX, United States	0.016%
Hydraulics / Hoses / Fittings	Cooper-Standard Automotive Fhs, Inc.	Chicago, IL, United States	0.016%
Vehicle Section - Qty Bearing	The Braun Corporation	Winamac, IN, United States	0.012%
Media / Decals / Literature	Webb Printing	Winamac, IN, United States	0.011%
OEM - Parts	Standard Industrial Supply	Winamac, IN, United States	0.010%
Media / Decals / Literature			0.009%
Heat, Ventilation, Air Cond.	Cooper-Standard Automotive Fhs, Inc.	Chicago, IL, United States	0.009%
Metal Machined Parts	MJ Celco, Inc.	Schiller Park, IL, United States	0.008%
NVH	GDC, Inc	Goshen, IN, United States	0.007%
Exhaust System & Components	Standard Industrial Supply	Winamac, IN, United States	0.007%
Hardware - Nuts Bolts & Screws	Umpco, Inc.	Garden Grove, CA, United States	0.005%
Wire / Harness / Loom	Vista Manufacturing Inc	Elkhart, IN, United States	0.005%
Electronics / Switches & Senso	Vista Manufacturing Inc.	Elkhart, IN, United States	0.003%
Heat, Ventilation, Air Cond.	Standard Integrated Solutions, Inc.	Winamac, IN, United States	0.003%
Media / Decals / Literature	Dec-O-Art, Inc.	Elkhart, IN, United States	0.003%
Media / Decals / Literature	DuraMark Technologies Inc.	Westfield, IN, United States	0.002%
Electronics / Switches & Senso	Umpco, Inc.	Garden Grove, CA, United States	0.002%
Hardware - Nuts Bolts & Screws	The Braun Corporation	Winamac, IN, United States	0.002%
Hardware - Nuts Bolts & Screws	Caplugs	Carol Stream, IL, United States	0.001%
Hardware - Nuts Bolts & Screws	EFC International	Chicago, IL, United States	0.001%
NVH	Standard Integrated Solutions, Inc.	Winamac, IN, United States	0.001%
Brake System	The Braun Corporation	Winamac, IN, United States	0.001%
Media / Decals / Literature	The Braun Corporation	Winamac, IN, United States	0.001%
Grand Total			72.194%

Cost of final assembly as related to cost of vehicle (percentage): 7.13%

Description of final assembly activities detailed on next page.

Date: 05/21/2024

Signature:

Print Name: Scott Alexander

Title: Commercial Vehicle Inside Sales Manager



Description of final assembly activities:

1. Braun's Final Assembly manufacturing processes consist of the following:
 - (a) "Seat Installation": Installation of seats in the first, second, and third seating rows in the vehicle.
 - (b) "Subsystem Installation": Installation of new lines for rear brake, fuel, heat, and air conditioning components.
 - (c) "Fuel Tank System Installation": Installed the fuel tank. Installation and interconnection of the new fuel fill pipe assembly to meet the relocated and rotated OEM fuel tank.
 - (d) "Exhaust Installation & Interconnection": Installing a new exhaust pipe, hanger brackets, and the OEM muffler.
 - (e) "Engine/Transmission/Front Suspension Assembly Modifications": Disconnecting the engine, transmission, and front suspension assembly in order to raise the body to accommodate the lowered floor. Modifications are made to the engine, transmission, and front suspension assembly, involve adding various types of spacing brackets, custom steering shaft extension, and two engine cradle safety bracket tube extensions, and reconnecting the engine, transmission, and front suspension assembly.
 - (f) "Slide Door Installation": Doors are installed and tested to verify proper travel and function.
 - (g) "Rear Axle & Suspension Installation & Interconnection": Installation of the rear axle, addition of brake line extensions, and rear brake lines fastened.
 - (h) "Flooring & Walls Installation": Installation of flooring substrate and covering and carpet or plastic panels with carpeted inserts. Walls are covered with new interior panels and trims.
 - (i) "Rear Bumper Installation": Installation of the reinforced rear bumper.
 - (j) "Wiring Installation": Installation of new and reroute existing wiring to accommodate the new seating systems, airbag systems, wheelchair ramp system, slide door operation, and other accessibility modifications such as kneeling function.
 - (k) "Ramp Installation & Interconnection": Installation and interconnection of the wheelchair ramp.
 - (l) "Undercoating": Newly installed components are coated, and the entire floor is undercoated.
 - (m) "Inspection & Certification": The vehicle is inspected, weighed, road tested, identified repairs completed if required, and recertified to all applicable FMVSS by Braun in preparation of the vehicles for delivery.



PRE-AWARD FMVSS COMPLIANCE CERTIFICATION

As required by 49 CFR part 663 - Subpart D, State of WV (the recipient) certifies that it received, at the pre-award stage, a copy of The Braun Corporation's (the manufacturer) self-certification information stating that the vehicles, ADA Lowered-Floor Minivan Side-Entry Fold-Out Ramp, will comply with the relevant Federal Motor Vehicle Safety Standard issued by the National Highway Traffic Safety Administration in 49 CFR part 571.

Date: 05/21/2024

Signature: *Scott Alexander*

Print Name: Scott Alexander

Title: Commercial Vehicle Inside Sales Manager

TIRE AND LOADING INFORMATION			
SEATING CAPACITY	TOTAL	FRONT	REAR
The combined weight of occupants and cargo should never exceed <input type="text"/> Kg or <input type="text"/> Lbs.			
TIRE	SIZE	COLD TIRE PRESSURE	SEE OWNER'S MANUAL FOR ADDITIONAL INFORMATION
FRONT			
REAR			
SPARE			

THE BRAUN CORPORATION
 631 w. 11th Street, Winamac, Indiana 46996

This Vehicle was altered by THE BRAUN CORPORATION in / and as altered it conforms to all applicable Federal Motor Vehicle Safety Bumper and Theft Prevention Standards affected by the alteration and in effect in /

Vehicle Type: MVP
 Vin #: _____

Available Payload Capacity: _____ LBS(Without Passengers & Wheelchairs)

MANUFACTURED BY:
 THE BRAUN CORPORATION ENTERVAN.COM®
 DATE OF MANUFACTURE MO. YR.

INCOMPLETE VEHICLE MANUFACTURED BY:
 CHRYSLER CORPORATION
 DATE INC. VEH. MFD. MO. YR.

GVWR(_____ KG) _____ LBS.
 GAWR FRONT(_____ KG) _____ LBS.
 WITH _____ TIRES
 _____ RIMS, @ _____ PSI COLD
 (_____ kPa cold)

GAWR REAR(_____ KG) _____ LBS.
 WITH _____ TIRES
 _____ RIMS, @ _____ PSI COLD
 (_____ kPa cold)

"THIS VEHICLE HAS BEEN COMPLETED IN ACCORDANCE WITH THE PRIOR MANUFACTURERS' IVD, WHERE APPLICABLE. THIS VEHICLE CONFORMS TO ALL APPLICABLE FEDERAL MOTOR VEHICLE SAFETY STANDARDS, (AND BUMPER AND THEFT PREVENTION STANDARDS, IF APPLICABLE) IN EFFECT IN (/),"
 (MONTH / YEAR)

VEHICLE IDENTIFICATION NO: _____

VEHICLE TYPE: MPV



Pre-Award Buy America

PURCHASER'S REQUIREMENTS CERTIFICATION

Purchaser - FTA Grantee	State of WV
Quantity	1
Description of Vehicles	ADA Lowered-Floor Minivan Side-Entry Fold-Out Ramp
Bid / RFP Contract Number	

As required by Title 49 of the CFR, Part 663 - Subpart B, **BraunAbility | The Braun Corporation of Winamac, Indiana** (the manufacturer) certifies that the documentation submitted in response to **State of WV** (the recipient) rolling stock procurement solicitation meets the required Bid Specification Compliance with the Purchaser's Solicitation Specifications.

The manufacturer certifies that the rolling stock vehicles to be manufactured for the recipient are the same product described in the recipient's solicitation specification and the manufacturer is a responsible manufacturer with the capability to produce a rolling stock vehicle that meets the recipient's specifications set forth in the recipient's solicitation.

Date: 05/21/2024

Signature:

Print Name: Scott Alexander

Title: Commercial Vehicle Inside Sales Manager



PERRY JOHNSON REGISTRARS, INC.

Certificate of Registration

Perry Johnson Registrars, Inc., has audited the Quality Management System of:

The Braun Corporation d.b.a. BraunAbility
631 West 11th Street, Winamac, IN 46996 United States

*(Hereinafter called the Organization) and hereby declares that
Organization is in conformance with:*

ISO 9001:2015

This Registration is in respect to the following scope:

***Design, Manufacture, and Assembly of Wheelchair Accessible Vehicles, Wheelchair Lifts for
Vehicle Applications, Wheelchair Toppers, and Other Mobility Products' Management Systems***

*This Registration is granted subject to the system rules governing the Registration referred to above, and the
Organization hereby covenants with the Assessment body duty to observe and comply with the said rules.*



Terry Boboige

Terry Boboige, President

Perry Johnson Registrars, Inc. (PJR)
755 West Big Beaver Road, Suite 1340
Troy, Michigan 48084
(248) 358-3388

The validity of this certificate is dependent upon ongoing surveillance.

Effective Date:
July 31, 2023

Expiration Date:
July 30, 2026

Certificate No.:
C2023-00382

David Clawson

From: Scott Alexander <Scott.Alexander@braunability.com>
Sent: Wednesday, May 29, 2024 2:55 PM
To: David Clawson
Cc: Kevin Shidler
Subject: corrected floor plan for WV submission
Attachments: RU Voyager ADA SE 2020M FP3.pdf

David – I just discovered that I provided the incorrect floorplan diagram with our documentation package. That floorplan did not show the 2nd row 2-passenger fold-away seat. Please see the attached corrected floorplan. I apologize for the oversight. Thanks – Scott

Scott Alexander | Associate Director, Commercial Inside Sales

BraunAbility | The Braun Corporation

631 W. 11th St. Winamac, IN 46996

PH 574-946-4139 Ext 3145

800-946-7513

Scott.Alexander@BraunAbility.com



The information contained in this e-mail message is privileged, confidential and protected from disclosure and discovery. If you are not the intended recipient, any dissemination, distribution, copying, or making available to be copied is strictly prohibited. If you think you have received this e-mail message in error, please alert the sender about the error. Thank you; we will extend the same courtesy. Any inconvenience to you for misdelivered messages is regretted.

In connection with the receipt of emails, BraunAbility generally obtains personal data. This personal data will be transferred to the United States and processed in accordance with (the from time to time) applicable data protection laws and BraunAbility's [Privacy Policy](#).

*** Please consider the environment before printing this email. ***

Seating Positions

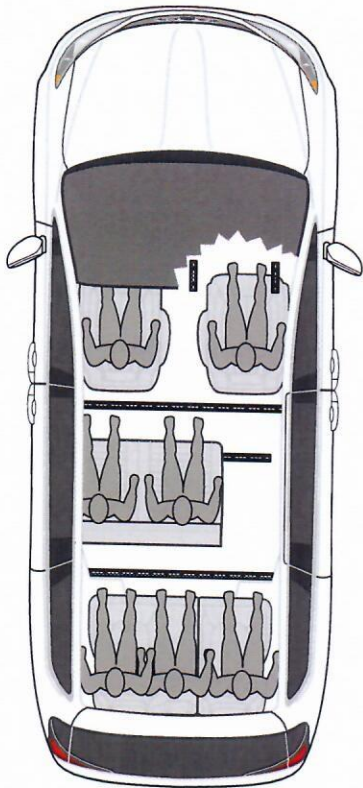

Possible Wheelchair Seating Positions

