



Department of Administration
 Purchasing Division
 2019 Washington Street East
 Post Office Box 50130
 Charleston, WV 25305-0130

State of West Virginia
 Centralized Request for Quote
 Public Safety

Proc Folder: 1386311			Reason for Modification:
Doc Description: REFLECTIVE ROLL-UP SIGNS			
Proc Type: Central Master Agreement			
Date Issued	Solicitation Closes	Solicitation No	Version
2024-03-06	2024-03-26 13:30	CRFQ 0803 DOT2400000081	1

BID RECEIVING LOCATION

BID CLERK
 DEPARTMENT OF ADMINISTRATION
 PURCHASING DIVISION
 2019 WASHINGTON ST E
 CHARLESTON WV 25305
 US

RECEIVED

2024 MAR 25 AM 10: 23

VENDOR

Vendor Customer Code: 000000179694

Vendor Name : Dicke Tool Company

Address : Dicke Tool Company

Street : 1201 Warren Ave.

City : Downers Grove

State : IL **Country :** USA **Zip :** 60515

Principal Contact : Scott Wolf

Vendor Contact Phone: 877-891-0050 **Extension:**

WV PURCHASING
DIVISION

FOR INFORMATION CONTACT THE BUYER
 John W Estep
 304-558-2566
 john.w.estep@wv.gov

Vendor Signature X  **FEIN#** 36-3087293 **DATE** 3-22-2024

All offers subject to all terms and conditions contained in this solicitation

ADDITIONAL INFORMATION**REQUEST FOR QUOTATION:**

The West Virginia Purchasing Division is soliciting bids on behalf of the West Virginia Division of Highways to establish an open-end contract for Reflective Roll-Up Signs. Per the Bid Requirements, Specifications, Terms and Conditions attached to this solicitation.

INVOICE TO**SHIP TO**

VARIOUS AGENCY
LOCATIONS

STATE OF WEST VIRGINIA

AS INDICATED BY ORDER

VARIOUS LOCATIONS AS
INDICATED BY ORDER

No City	WV	No City	WV
US		US	

Line	Comm Ln Desc	Qty	Unit Issue	Unit Price	Total Price
1	36" R1-1F "STOP" sign	1.00000	EA	73.01	73.01

Comm Code	Manufacturer	Specification	Model #
55120000	Dicke Tool		RUR36OCT-MAR-WV

Extended Description:

36" R1-1F "STOP" sign

INVOICE TO**SHIP TO**

VARIOUS AGENCY
LOCATIONS

STATE OF WEST VIRGINIA

AS INDICATED BY ORDER

VARIOUS LOCATIONS AS
INDICATED BY ORDER

No City	WV	No City	WV
US		US	

Line	Comm Ln Desc	Qty	Unit Issue	Unit Price	Total Price
2	48" R1-1F "STOP" sign	5.00000	EA	128.75	643.76

Comm Code	Manufacturer	Specification	Model #
55120000	Dicke Tool		RUR48-OCT-MAR

Extended Description:

48" R1-1F "STOP" sign

INVOICE TO		SHIP TO	
VARIOUS AGENCY LOCATIONS AS INDICATED BY ORDER		STATE OF WEST VIRGINIA VARIOUS LOCATIONS AS INDICATED BY ORDER	
No City US	WV	No City US	WV

Line	Comm Ln Desc	Qty	Unit Issue	Unit Price	Total Price
3	36" W3-1MF SYMBOLIC "STOP AHEAD" sign	1.00000	EA	109.11	109.11

Comm Code	Manufacturer	Specification	Model #
55120000	Dicke Tool		RUR36MAR-M-WV

Extended Description:
36" W3-1MF SYMBOLIC "STOP AHEAD" sign

INVOICE TO		SHIP TO	
VARIOUS AGENCY LOCATIONS AS INDICATED BY ORDER		STATE OF WEST VIRGINIA VARIOUS LOCATIONS AS INDICATED BY ORDER	
No City US	WV	No City US	WV

Line	Comm Ln Desc	Qty	Unit Issue	Unit Price	Total Price
4	48" W3-1MF SYMBOLIC "STOP AHEAD" sign	5.00000	EA	171.46	857.31

Comm Code	Manufacturer	Specification	Model #
55120000	Dicke Tool		RUR48MAR-MULTI-WV

Extended Description:
48" W3-1MF SYMBOLIC "STOP AHEAD" sign

INVOICE TO	SHIP TO
-------------------	----------------

VARIOUS AGENCY LOCATIONS AS INDICATED BY ORDER		STATE OF WEST VIRGINIA VARIOUS LOCATIONS AS INDICATED BY ORDER	
No City US	WW	No City US	WW

Line	Comm Ln Desc	Qty	Unit Issue	Unit Price	Total Price
5	36" R1-2F "YIELD" sign	1.00000	EA	73.01	73.01

Comm Code	Manufacturer	Specification	Model #
55120000	Dicke Tool		RUR36YIELDMAR-WW

Extended Description:
36" R1-2F "YIELD" sign

INVOICE TO	SHIP TO
-------------------	----------------

VARIOUS AGENCY LOCATIONS AS INDICATED BY ORDER		STATE OF WEST VIRGINIA VARIOUS LOCATIONS AS INDICATED BY ORDER	
No City US	WW	No City US	WW

Line	Comm Ln Desc	Qty	Unit Issue	Unit Price	Total Price
6	48" R1-2F "YIELD" sign	30.00000	EA	128.75	3,862.58

Comm Code	Manufacturer	Specification	Model #
55120000	Dicke Tool		RUR48YIELDMAR-WW

Extended Description:
48" R1-2F "YIELD" sign

INVOICE TO		SHIP TO	
VARIOUS AGENCY LOCATIONS AS INDICATED BY ORDER		STATE OF WEST VIRGINIA VARIOUS LOCATIONS AS INDICATED BY ORDER	
No City US	WV	No City US	WV

Line	Comm Ln Desc	Qty	Unit Issue	Unit Price	Total Price
7	36" W3-2MF SYMBOLIC "YIELD AHEAD" sign	1.00000	EA	109.11	109.11

Comm Code	Manufacturer	Specification	Model #
55120000	Dicke Tool		RUR36MAR-M-WV

Extended Description:
36" W3-2MF SYMBOLIC "YIELD AHEAD" sign

INVOICE TO		SHIP TO	
VARIOUS AGENCY LOCATIONS AS INDICATED BY ORDER		STATE OF WEST VIRGINIA VARIOUS LOCATIONS AS INDICATED BY ORDER	
No City US	WV	No City US	WV

Line	Comm Ln Desc	Qty	Unit Issue	Unit Price	Total Price
8	48" W3-2MF SYMBOLIC "YIELD AHEAD" sign	5.00000	EA	171.46	857.31

Comm Code	Manufacturer	Specification	Model #
55120000	Dicke Tool		RUR48MAR-MULTI-WV

Extended Description:
48" W3-2MF SYMBOLIC "YIELD AHEAD" sign

INVOICE TO		SHIP TO	
VARIOUS AGENCY LOCATIONS AS INDICATED BY ORDER		STATE OF WEST VIRGINIA	
No City US		No City US	
WV		WV	
		VARIOUS LOCATIONS AS INDICATED BY ORDER	

Line	Comm Ln Desc	Qty	Unit Issue	Unit Price	Total Price
9	36" x 60" R2-1MF "WORK ZONE SPEED LIMIT _____" W/ HOOK & LOOP	10.00000	EA	163.00	1,630.00

Comm Code	Manufacturer	Specification	Model #
55120000	Dicke Tool		RUR3660MAR-WV

Extended Description:
 36" x 60" R2-1MF "WORK ZONE SPEED LIMIT _____" W/ HOOK & LOOP FOR NUMERAL OVERLAY PLAQUES (ORDER NUMERALS UNDER ITEM #10)

INVOICE TO		SHIP TO	
VARIOUS AGENCY LOCATIONS AS INDICATED BY ORDER		STATE OF WEST VIRGINIA	
No City US		No City US	
WV		WV	
		VARIOUS LOCATIONS AS INDICATED BY ORDER	

Line	Comm Ln Desc	Qty	Unit Issue	Unit Price	Total Price
10	14" X 17" NUMERAL OVERLAY PLAQUES FOR ITEM NUMBER 9 (SPECIFY	1.00000	EA	19.05	19.05

Comm Code	Manufacturer	Specification	Model #
55120000	Dicke Tool		FPO48MAR

Extended Description:
 14" X 17" NUMERAL OVERLAY PLAQUES FOR ITEM NUMBER 9 (SPECIFY QTY OF EACH INDIVIDUAL NUMERAL TO BE SUPPLIED)

INVOICE TO		SHIP TO	
VARIOUS AGENCY LOCATIONS AS INDICATED BY ORDER		STATE OF WEST VIRGINIA VARIOUS LOCATIONS AS INDICATED BY ORDER	
No City US	WW	No City US	WW

Line	Comm Ln Desc	Qty	Unit Issue	Unit Price	Total Price
11	48" X 24" R4-14(L/R)F "ALL TRAFFIC (W/ INTERCHANGEABLE ARRO	10.00000	EA	107.95	1,079.50

Comm Code	Manufacturer	Specification	Model #
55120000	Dicke Tool		RUR2448MAR-WW

Extended Description:
48" X 24" R4-14(L/R)F "ALL TRAFFIC (W/ INTERCHANGEABLE ARROW HEAD)"

INVOICE TO		SHIP TO	
VARIOUS AGENCY LOCATIONS AS INDICATED BY ORDER		STATE OF WEST VIRGINIA VARIOUS LOCATIONS AS INDICATED BY ORDER	
No City US	WW	No City US	WW

Line	Comm Ln Desc	Qty	Unit Issue	Unit Price	Total Price
12	24"x30" R4-7BF "KEEP RIGHT" SIGN	1.00000	EA	70.36	70.36

Comm Code	Manufacturer	Specification	Model #
55120000	Dicke Tool		RUR2430MAR-WW

Extended Description:
24"x30" R4-7BF "KEEP RIGHT" SIGN

INVOICE TO		SHIP TO	
VARIOUS AGENCY LOCATIONS AS INDICATED BY ORDER		STATE OF WEST VIRGINIA	
No City US		No City US	
WV		WV	
		VARIOUS LOCATIONS AS INDICATED BY ORDER	

Line	Comm Ln Desc	Qty	Unit Issue	Unit Price	Total Price
13	36"X48" R4-7BF "KEEP RIGHT" SIGN	1.00000	EA	112.61	112.61

Comm Code	Manufacturer	Specification	Model #
55120000	Dicke Tool		RUR3648MAR-WV

Extended Description:
36"X48" R4-7BF "KEEP RIGHT" SIGN

INVOICE TO		SHIP TO	
VARIOUS AGENCY LOCATIONS AS INDICATED BY ORDER		STATE OF WEST VIRGINIA	
No City US		No City US	
WV		WV	
		VARIOUS LOCATIONS AS INDICATED BY ORDER	

Line	Comm Ln Desc	Qty	Unit Issue	Unit Price	Total Price
14	30"X18" R9-9F "SIDEWALK CLOSED"	1.00000	EA	62.51	62.51

Comm Code	Manufacturer	Specification	Model #
55120000	Dicke Tool		RUR3018MAR-WV

Extended Description:
30"X18" R9-9F "SIDEWALK CLOSED"

INVOICE TO		SHIP TO	
VARIOUS AGENCY LOCATIONS AS INDICATED BY ORDER		STATE OF WEST VIRGINIA VARIOUS LOCATIONS AS INDICATED BY ORDER	
No City US	WW	No City US	WW

Line	Comm Ln Desc	Qty	Unit Issue	Unit Price	Total Price
15	48"X30" R11-2F "ROAD CLOSED" W/ HOOK & LOOP FOR OVERLAY PLAQ	50.00000	EA	99.97	4,998.72

Comm Code	Manufacturer	Specification	Model #
55120000	Dicke Tool		RUR3048MAR-WW

Extended Description:

48"X30" R11-2F "ROAD CLOSED" W/ HOOK & LOOP FOR OVERLAY PLAQUES (ORDER "BRIDGE" AND "RAMP" OVERLAYS UNDER ITEM #16)

INVOICE TO		SHIP TO	
VARIOUS AGENCY LOCATIONS AS INDICATED BY ORDER		STATE OF WEST VIRGINIA VARIOUS LOCATIONS AS INDICATED BY ORDER	
No City US	WW	No City US	WW

Line	Comm Ln Desc	Qty	Unit Issue	Unit Price	Total Price
16	10" X 39" "BRIDGE" AND "RAMP" OVERLAY PLAQUES FOR ITEM 15 (S	50.00000	EA	29.21	1,460.50

Comm Code	Manufacturer	Specification	Model #
55120000	Dicke Tool		FPO48MAR

Extended Description:

10" X 39" "BRIDGE" AND "RAMP" OVERLAY PLAQUES FOR ITEM 15 (SPECIFY QTY OF EACH INDIVIDUAL PLAQUE TO BE SUPPLIED)

INVOICE TO		SHIP TO	
VARIOUS AGENCY LOCATIONS AS INDICATED BY ORDER		STATE OF WEST VIRGINIA	
No City US		No City US	
WV		WV	
		VARIOUS LOCATIONS AS INDICATED BY ORDER	

Line	Comm Ln Desc	Qty	Unit Issue	Unit Price	Total Price
17	60" X 30" R11-3AF "ROAD CLOSED _____ MI AHEAD LOCAL TRAFFIC	10.00000	EA	155.18	1,551.80

Comm Code	Manufacturer	Specification	Model #
55120000	Dicke Tool		RUR3660MAR-WV

Extended Description:
60" X 30" R11-3AF "ROAD CLOSED _____ MI AHEAD LOCAL TRAFFIC ONLY" W/ HOOK & LOOP FOR NUMERAL OVERLAY PLAQUES (ORDER NUMERALS UNDER ITEM #18)

INVOICE TO		SHIP TO	
VARIOUS AGENCY LOCATIONS AS INDICATED BY ORDER		STATE OF WEST VIRGINIA	
No City US		No City US	
WV		WV	
		VARIOUS LOCATIONS AS INDICATED BY ORDER	

Line	Comm Ln Desc	Qty	Unit Issue	Unit Price	Total Price
18	5" X 7" NUMERAL OVERLAY PLAQUES FOR ITEM NUMBER 17 (SPECIFY	40.00000	EA	13.58	543.05

Comm Code	Manufacturer	Specification	Model #
55120000	Dicke Tool		FPO48MAR

Extended Description:
5" X 7" NUMERAL OVERLAY PLAQUES FOR ITEM NUMBER 17 (SPECIFY QTY OF EACH INDIVIDUAL NUMERAL TO BE SUPPLIED)

INVOICE TO		SHIP TO	
VARIOUS AGENCY LOCATIONS AS INDICATED BY ORDER		STATE OF WEST VIRGINIA	
No City US		No City US	
WW		WW	
		VARIOUS LOCATIONS AS INDICATED BY ORDER	

Line	Comm Ln Desc	Qty	Unit Issue	Unit Price	Total Price
19	60"X30" R11-4F "ROAD CLOSED TO THRU TRAFFIC"	10.00000	EA	151.37	1,513.70

Comm Code	Manufacturer	Specification	Model #
55120000	Dicke Tool		RUR3060MAR-WV

Extended Description:
60"X30" R11-4F "ROAD CLOSED TO THRU TRAFFIC"

INVOICE TO		SHIP TO	
VARIOUS AGENCY LOCATIONS AS INDICATED BY ORDER		STATE OF WEST VIRGINIA	
No City US		No City US	
WW		WW	
		VARIOUS LOCATIONS AS INDICATED BY ORDER	

Line	Comm Ln Desc	Qty	Unit Issue	Unit Price	Total Price
20	48"X36" W22-10F "EXIT _____" W/ HOOK & LOOP FOR OVERLAYS (1.00000	EA	120.23	120.23

Comm Code	Manufacturer	Specification	Model #
55120000	Dicke Tool		RUR3648MAR-WV

Extended Description:
48"X36" W22-10F "EXIT _____" W/ HOOK & LOOP FOR OVERLAYS (ORDER "OPEN" AND "CLOSED" PLAQUES UNDER ITEM #21)

INVOICE TO		SHIP TO	
VARIOUS AGENCY LOCATIONS AS INDICATED BY ORDER		STATE OF WEST VIRGINIA	
No City US		No City US	
WW		WW	
AS INDICATED BY ORDER		VARIOUS LOCATIONS AS INDICATED BY ORDER	

Line	Comm Ln Desc	Qty	Unit Issue	Unit Price	Total Price
21	10" X 40" "OPEN" AND "CLOSED" OVERLAY PLAQUES FOR ITEM 20 (1.00000	EA	29.21	29.21

Comm Code	Manufacturer	Specification	Model #
55120000	Dicke Tool		FPO48MAR

Extended Description:
 10" X 40" "OPEN" AND "CLOSED" OVERLAY PLAQUES FOR ITEM 20 (SPECIFY QTY OF EACH INDIVIDUAL PLAQUE TO BE SUPPLIED)

INVOICE TO		SHIP TO	
VARIOUS AGENCY LOCATIONS AS INDICATED BY ORDER		STATE OF WEST VIRGINIA	
No City US		No City US	
WW		WW	
AS INDICATED BY ORDER		VARIOUS LOCATIONS AS INDICATED BY ORDER	

Line	Comm Ln Desc	Qty	Unit Issue	Unit Price	Total Price
22	60"X60" W22-11F EXIT GORE SIGN	1.00000	EA	184.15	184.15

Comm Code	Manufacturer	Specification	Model #
55120000	Dicke Tool		RUR6060MAR-WV

Extended Description:
 60"X60" W22-11F EXIT GORE SIGN

INVOICE TO		SHIP TO	
VARIOUS AGENCY LOCATIONS AS INDICATED BY ORDER		STATE OF WEST VIRGINIA VARIOUS LOCATIONS AS INDICATED BY ORDER	
No City US	WW	No City US	WW

Line	Comm Ln Desc	Qty	Unit Issue	Unit Price	Total Price
23	30"X24" M4-9F STANDARD DETOUR SIGN W/ HOOK & LOOP AND ARROW	1.00000	EA	87.63	87.63

Comm Code	Manufacturer	Specification	Model #
55120000	Dicke Tool		RUR2430MAR-WV

Extended Description:
30"X24" M4-9F STANDARD DETOUR SIGN W/ HOOK & LOOP AND ARROW OVERLAY PLAQUE

INVOICE TO		SHIP TO	
VARIOUS AGENCY LOCATIONS AS INDICATED BY ORDER		STATE OF WEST VIRGINIA VARIOUS LOCATIONS AS INDICATED BY ORDER	
No City US	WW	No City US	WW

Line	Comm Ln Desc	Qty	Unit Issue	Unit Price	Total Price
24	48"X48" EMERGENCY RESPONSE TRAILER DETOUR SIGN W/ HOOK & LOO	10.00000	EA	119.66	1,196.60

Comm Code	Manufacturer	Specification	Model #
55120000	Dicke Tool		RUR48MAR-WV

Extended Description:
48"X48" EMERGENCY RESPONSE TRAILER DETOUR SIGN W/ HOOK & LOOP FOR OVERLAY PLAQUES AND ARROW OVERLAY PLAQUE (ORDER ROUTE AND CARDINAL DIRECTION PLAQUES UNDER ITEM NUMBERS 25 & 26)

INVOICE TO		SHIP TO	
VARIOUS AGENCY LOCATIONS AS INDICATED BY ORDER		STATE OF WEST VIRGINIA VARIOUS LOCATIONS AS INDICATED BY ORDER	
No City US	WW	No City US	WW

Line	Comm Ln Desc	Qty	Unit Issue	Unit Price	Total Price
25	9" X 28" EMERGENCY RESPONSE TRAILER ROUTE OVERLAY PLAQUE FOR	30.00000	EA	13.58	407.39

Comm Code	Manufacturer	Specification	Model #
55120000	Dicke Tool		FPO48MAR

Extended Description:

9" X 28" EMERGENCY RESPONSE TRAILER ROUTE OVERLAY PLAQUE FOR ITEM 24 (SPECIFY EACH INDIVIDUAL ROUTE PLAQUE TO BE SUPPLIED AND QTY OF EACH)

INVOICE TO		SHIP TO	
VARIOUS AGENCY LOCATIONS AS INDICATED BY ORDER		STATE OF WEST VIRGINIA VARIOUS LOCATIONS AS INDICATED BY ORDER	
No City US	WW	No City US	WW

Line	Comm Ln Desc	Qty	Unit Issue	Unit Price	Total Price
26	9" X 7" EMERGENCY RESPONSE TRAILER CARDINAL DIRECTION OVERL	1.00000	EA	13.58	13.58

Comm Code	Manufacturer	Specification	Model #
55120000	Dicke Tool		FPO48MAR

Extended Description:

9" X 7" EMERGENCY RESPONSE TRAILER CARDINAL DIRECTION OVERLAY PLAQUE FOR ITEM 24 (SPECIFY QTY OF EACH "N", "S", "E", AND "W" PLAQUES TO BE SUPPLIED)

INVOICE TO		SHIP TO	
VARIOUS AGENCY LOCATIONS AS INDICATED BY ORDER		STATE OF WEST VIRGINIA	
No City US		No City US	
WV		WV	
		VARIOUS LOCATIONS AS INDICATED BY ORDER	

Line	Comm Ln Desc	Qty	Unit Issue	Unit Price	Total Price
27	48" x 48" DIAMOND, FLUORESCENT ORANGE, STANDARD MESSAGE ROLL	35.00000	EA	115.85	4,054.73

Comm Code	Manufacturer	Specification	Model #
55120000	Dicke Tool		RUR48MAR-WV

Extended Description:
 48" x 48" DIAMOND, FLUORESCENT ORANGE, STANDARD MESSAGE ROLL-UP SIGN (SPECIFY QUANTITY OF EACH FABRICATION NUMBER TO BE SUPPLIED)

INVOICE TO		SHIP TO	
VARIOUS AGENCY LOCATIONS AS INDICATED BY ORDER		STATE OF WEST VIRGINIA	
No City US		No City US	
WV		WV	
		VARIOUS LOCATIONS AS INDICATED BY ORDER	

Line	Comm Ln Desc	Qty	Unit Issue	Unit Price	Total Price
28	48" x 48" DIAMOND, FLUORESCENT ORANGE, STANDARD MESSAGE ROL	570.00000	EA	126.67	72,201.79

Comm Code	Manufacturer	Specification	Model #
55120000	Dicke Tool		RUR48MARFFS-WV

Extended Description:
 48" x 48" DIAMOND, FLUORESCENT ORANGE, STANDARD MESSAGE ROLL-UP SIGN, W/ PERMANENT ADDITION OF TWO (2) 18" X 18" VINYL FOLDING FLAGS. (SPECIFY QUANTITY OF EACH FABRICATION NUMBER TO BE SUPPLIED)

INVOICE TO		SHIP TO	
VARIOUS AGENCY LOCATIONS AS INDICATED BY ORDER		STATE OF WEST VIRGINIA VARIOUS LOCATIONS AS INDICATED BY ORDER	
No City US	WW	No City US	WW

Line	Comm Ln Desc	Qty	Unit Issue	Unit Price	Total Price
29	36" x 36" DIAMOND, FLUORESCENT ORANGE, STANDARD MESSAGE ROL	640.00000	EA	79.17	50,669.95

Comm Code	Manufacturer	Specification	Model #
55120000	Dicke Tool		RUR36MAR-WW

Extended Description:
36" x 36" DIAMOND, FLUORESCENT ORANGE, STANDARD MESSAGE ROLL-UP SIGN (SPECIFY QUANTITY OF EACH FABRICATION NUMBER TO BE SUPPLIED)

INVOICE TO		SHIP TO	
VARIOUS AGENCY LOCATIONS AS INDICATED BY ORDER		STATE OF WEST VIRGINIA VARIOUS LOCATIONS AS INDICATED BY ORDER	
No City US	WW	No City US	WW

Line	Comm Ln Desc	Qty	Unit Issue	Unit Price	Total Price
30	36" x 36" DIAMOND, FLUORESCENT ORANGE, STANDARD MESSAGE ROL	750.00000	EA	89.98	67,484.63

Comm Code	Manufacturer	Specification	Model #
55120000	Dicke Tool		RUR36MARFFS-WW

Extended Description:
36" x 36" DIAMOND, FLUORESCENT ORANGE, STANDARD MESSAGE ROLL-UP SIGN, WITH PERMANENT ADDITION OF TWO (2) 18"X18" VINYL FOLDING FLAGS . (SPECIFY QUANTITY OF EACH FABRICATION NUMBER TO BE SUPPLIED)

INVOICE TO		SHIP TO	
VARIOUS AGENCY LOCATIONS AS INDICATED BY ORDER		STATE OF WEST VIRGINIA VARIOUS LOCATIONS AS INDICATED BY ORDER	
No City US	WW	No City US	WW

Line	Comm Ln Desc	Qty	Unit Issue	Unit Price	Total Price
31	48" x 48" DIAMOND, FLUORESCENT ORANGE, STANDARD MESSAGE ROLL	85.00000	EA	119.66	10,171.05

Comm Code	Manufacturer	Specification	Model #
55120000	Dicke Tool		RUR48MAR-WV

Extended Description:
 48" x 48" DIAMOND, FLUORESCENT ORANGE, STANDARD MESSAGE ROLL-UP SIGN WITH HOOK & LOOP STRIPS FOR OVERLAY ATTACHMENTS (SPECIFY QTY OF EACH FABRICATION NUMBER TO BE SUPPLIED AND PORTION OF TEXT INTENDED TO BE COVERED WITH OVERLAY PLAQUES - ORDER OVERLAY PLAQUES UNDER BID ITEM 35)

INVOICE TO		SHIP TO	
VARIOUS AGENCY LOCATIONS AS INDICATED BY ORDER		STATE OF WEST VIRGINIA VARIOUS LOCATIONS AS INDICATED BY ORDER	
No City US	WW	No City US	WW

Line	Comm Ln Desc	Qty	Unit Issue	Unit Price	Total Price
32	48" x 48" DIAMOND, FLUORESCENT ORANGE, STANDARD MESSAGE ROLL	175.00000	EA	130.48	22,833.97

Comm Code	Manufacturer	Specification	Model #
55120000	Dicke Tool		RUR48MARFFS-WV

Extended Description:
 48" x 48" DIAMOND, FLUORESCENT ORANGE, STANDARD MESSAGE ROLL-UP SIGN WITH PERMANENT ADDITION OF TWO (2) 18"X18" VINYL FOLDING FLAGS, AND HOOK & LOOP STRIPS FOR OVERLAY ATTACHMENTS (SPECIFY QTY OF EACH FABRICATION NUMBER TO BE SUPPLIED AND PORTION OF TEXT INTENDED TO BE COVERED WITH OVERLAY PLAQUES - ORDER OVERLAY PLAQUES UNDER BID ITEM 35)

INVOICE TO		SHIP TO	
VARIOUS AGENCY LOCATIONS AS INDICATED BY ORDER		STATE OF WEST VIRGINIA VARIOUS LOCATIONS AS INDICATED BY ORDER	
No City US	WW	No City US	WW

Line	Comm Ln Desc	Qty	Unit Issue	Unit Price	Total Price
33	36" x 36" DIAMOND, FLUORESCENT ORANGE, STANDARD MESSAGE ROL	1.00000	EA	82.98	82.98

Comm Code	Manufacturer	Specification	Model #
55120000	Dicke Tool		RUR36MAR-WV

Extended Description:
 36" x 36" DIAMOND, FLUORESCENT ORANGE, STANDARD MESSAGE ROLL-UP SIGN WITH HOOK & LOOP STRIPS FOR OVERLAY ATTACHMENTS (SPECIFY QTY OF EACH FABRICATION NUMBER TO BE SUPPLIED AND PORTION OF TEXT INTENDED TO BE COVERED WITH OVERLAY PLAQUES - ORDER OVERLAY PLAQUES UNDER BID ITEM 36)

INVOICE TO		SHIP TO	
VARIOUS AGENCY LOCATIONS AS INDICATED BY ORDER		STATE OF WEST VIRGINIA VARIOUS LOCATIONS AS INDICATED BY ORDER	
No City US	WW	No City US	WW

Line	Comm Ln Desc	Qty	Unit Issue	Unit Price	Total Price
34	36" x 36" DIAMOND, FLUORESCENT ORANGE, STANDARD MESSAGE ROL	60.00000	EA	93.79	5,627.37

Comm Code	Manufacturer	Specification	Model #
55120000	Dicke Tool		RUR36MARFFS-WV

Extended Description:
 36" x 36" DIAMOND, FLUORESCENT ORANGE, STANDARD MESSAGE ROLL-UP SIGN WITH PERMANENT ADDITION OF TWO (2) 18"X18" VINYL FOLDING FLAGS, AND HOOK & LOOP STRIPS FOR OVERLAY ATTACHMENTS (SPECIFY QTY OF EACH FABRICATION NUMBER TO BE SUPPLIED AND PORTION OF TEXT INTENDED TO BE COVERED WITH OVERLAY PLAQUES - ORDER OVERLAY PLAQUES UNDER BID ITEM 36)

INVOICE TO		SHIP TO	
VARIOUS AGENCY LOCATIONS AS INDICATED BY ORDER		STATE OF WEST VIRGINIA VARIOUS LOCATIONS AS INDICATED BY ORDER	
No City US	WW	No City US	WW

Line	Comm Ln Desc	Qty	Unit Issue	Unit Price	Total Price
35	8" X 21" ("LEFT" AND "CENTER" TEXT ONLY) OR 8" x 28" FLUORE	310.00000	EA	13.53	4,192.91

Comm Code	Manufacturer	Specification	Model #
55120000	Dicke Tool		FPO822MAR

Extended Description:
8" X 21" ("LEFT" AND "CENTER" TEXT ONLY) OR 8" x 28" FLUORESCENT ORANGE OVERLAYS WITH H&L STRIPS FOR USE WITH ITEM NUMBERS 33 AND 34. EXAMPLES: LEFT, 500 FT., 1000 FT., 1500 FT., 1/2 MILE, AND 1 MILE (SPECIFY QUANTITY OF EACH PLAQUE TO BE SUPPLIED)

INVOICE TO		SHIP TO	
VARIOUS AGENCY LOCATIONS AS INDICATED BY ORDER		STATE OF WEST VIRGINIA VARIOUS LOCATIONS AS INDICATED BY ORDER	
No City US	WW	No City US	WW

Line	Comm Ln Desc	Qty	Unit Issue	Unit Price	Total Price
36	6" x 21" FLUORESCENT ORANGE OVERLAYS WITH H&L STRIPS FOR USE	10.00000	EA	13.53	135.26

Comm Code	Manufacturer	Specification	Model #
55120000	Dicke Tool		FPO822MAR

Extended Description:
6" x 21" FLUORESCENT ORANGE OVERLAYS WITH H&L STRIPS FOR USE WITH ITEM NUMBERS 35 AND 36. EXAMPLES: LEFT, 500 FT., 1000 FT., 1500 FT., 1/2 MILE, 1 MILE, and AHEAD (SPECIFY QUANTITY OF EACH PLAQUE TO BE SUPPLIED)

INVOICE TO		SHIP TO	
VARIOUS AGENCY LOCATIONS AS INDICATED BY ORDER		STATE OF WEST VIRGINIA VARIOUS LOCATIONS AS INDICATED BY ORDER	
No City US	WW	No City US	WW

Line	Comm Ln Desc	Qty	Unit Issue	Unit Price	Total Price
37	18"x36" G20-2 "END ROAD WORK" SIGN	1.00000	EA	68.78	68.78

Comm Code	Manufacturer	Specification	Model #
55120000	Dicke Tool		RUR1836MAR-WV

Extended Description:
18"x36" G20-2 "END ROAD WORK" SIGN

INVOICE TO		SHIP TO	
VARIOUS AGENCY LOCATIONS AS INDICATED BY ORDER		STATE OF WEST VIRGINIA VARIOUS LOCATIONS AS INDICATED BY ORDER	
No City US	WW	No City US	WW

Line	Comm Ln Desc	Qty	Unit Issue	Unit Price	Total Price
38	36" W3-1MF SYMBOLIC "STOP AHEAD" sign, fluorescent-pink	1.00000	EA	109.11	109.11

Comm Code	Manufacturer	Specification	Model #
55120000	Dicke Tool		RUR36PNKSIGN

Extended Description:
36" W3-1MF SYMBOLIC "STOP AHEAD" sign, fluorescent-pink

INVOICE TO		SHIP TO	
VARIOUS AGENCY LOCATIONS AS INDICATED BY ORDER		STATE OF WEST VIRGINIA	
No City US		No City US	
WW		WW	
		VARIOUS LOCATIONS AS INDICATED BY ORDER	

Line	Comm Ln Desc	Qty	Unit Issue	Unit Price	Total Price
39	48" W3-1MF SYMBOLIC "STOP AHEAD" sign, fluorescent-pink	1.00000	EA	171.76	171.76

Comm Code	Manufacturer	Specification	Model #
55120000	Dicke Tool		RUR48PNKSIGN

Extended Description:
48" W3-1MF SYMBOLIC "STOP AHEAD" sign, fluorescent-pink

INVOICE TO		SHIP TO	
VARIOUS AGENCY LOCATIONS AS INDICATED BY ORDER		STATE OF WEST VIRGINIA	
No City US		No City US	
WW		WW	
		VARIOUS LOCATIONS AS INDICATED BY ORDER	

Line	Comm Ln Desc	Qty	Unit Issue	Unit Price	Total Price
40	36" W3-2MF SYMBOLIC "YIELD AHEAD" sign, fluorescent-pink	1.00000	EA	109.11	109.11

Comm Code	Manufacturer	Specification	Model #
55120000	Dicke Tool		RUR36PNKSIGN

Extended Description:
36" W3-2MF SYMBOLIC "YIELD AHEAD" sign, fluorescent-pink

INVOICE TO		SHIP TO	
VARIOUS AGENCY LOCATIONS AS INDICATED BY ORDER		STATE OF WEST VIRGINIA VARIOUS LOCATIONS AS INDICATED BY ORDER	
No City US	WW	No City US	WW

Line	Comm Ln Desc	Qty	Unit Issue	Unit Price	Total Price
41	48" W3-2MF SYMBOLIC "YIELD AHEAD" sign, fluorescent-pink	1.00000	EA	171.46	171.46

Comm Code	Manufacturer	Specification	Model #
55120000	Dicke Tool		RUR48PNKSIGN

Extended Description:
48" W3-2MF SYMBOLIC "YIELD AHEAD" sign, fluorescent-pink

INVOICE TO		SHIP TO	
VARIOUS AGENCY LOCATIONS AS INDICATED BY ORDER		STATE OF WEST VIRGINIA VARIOUS LOCATIONS AS INDICATED BY ORDER	
No City US	WW	No City US	WW

Line	Comm Ln Desc	Qty	Unit Issue	Unit Price	Total Price
42	48"X36" W22-10F "EXIT _____" W/ HOOK & LOOP FOR OVERLAYS,	1.00000	EA	126.37	126.37

Comm Code	Manufacturer	Specification	Model #
55120000	Dicke Tool		RUR4836PNKSIGN

Extended Description:
48"X36" W22-10F "EXIT _____" W/ HOOK & LOOP FOR OVERLAYS, fluorescent-pink (ORDER "OPEN" AND "CLOSED" PLAQUES UNDER ITEM #49)

INVOICE TO		SHIP TO	
VARIOUS AGENCY LOCATIONS AS INDICATED BY ORDER		STATE OF WEST VIRGINIA VARIOUS LOCATIONS AS INDICATED BY ORDER	
No City US	WW	No City US	WW

Line	Comm Ln Desc	Qty	Unit Issue	Unit Price	Total Price
43	10" X 40" "OPEN" AND "CLOSED" OVERLAY PLAQUES FOR ITEM 48, f	1.00000	EA	29.21	29.21

Comm Code	Manufacturer	Specification	Model #
55120000	Dicke Tool		FPO1034PNK

Extended Description:

10" X 40" "OPEN" AND "CLOSED" OVERLAY PLAQUES FOR ITEM 48, fluorescent-pink (SPECIFY QTY OF EACH INDIVIDUAL PLAQUE TO BE SUPPLIED)

INVOICE TO		SHIP TO	
VARIOUS AGENCY LOCATIONS AS INDICATED BY ORDER		STATE OF WEST VIRGINIA VARIOUS LOCATIONS AS INDICATED BY ORDER	
No City US	WW	No City US	WW

Line	Comm Ln Desc	Qty	Unit Issue	Unit Price	Total Price
44	30"X24" M4-9F STANDARD DETOUR SIGN W/ HOOK & LOOP AND ARROW	1.00000	EA	91.55	91.55

Comm Code	Manufacturer	Specification	Model #
55120000	Dicke Tool		RUR3024PNKSIGN

Extended Description:

30"X24" M4-9F STANDARD DETOUR SIGN W/ HOOK & LOOP AND ARROW OVERLAY PLAQUE, fluorescent-pink

INVOICE TO		SHIP TO	
VARIOUS AGENCY LOCATIONS AS INDICATED BY ORDER		STATE OF WEST VIRGINIA VARIOUS LOCATIONS AS INDICATED BY ORDER	
No City US	WV	No City US	WV

Line	Comm Ln Desc	Qty	Unit Issue	Unit Price	Total Price
45	48"X48" EMERGENCY RESPONSE TRAILER DETOUR SIGN W/ HOOK & LOO	1.00000	EA	96.04	96.04

Comm Code	Manufacturer	Specification	Model #
55120000	Dicke Tool		RUR48PNKSIGN

Extended Description:

48"X48" EMERGENCY RESPONSE TRAILER DETOUR SIGN W/ HOOK & LOOP FOR OVERLAY PLAQUES AND ARROW OVERLAY PLAQUE, fluorescent-pink (ORDER ROUTE AND CARDINAL DIRECTION PLAQUES UNDER ITEM NUMBERS 52 & 53)

INVOICE TO		SHIP TO	
VARIOUS AGENCY LOCATIONS AS INDICATED BY ORDER		STATE OF WEST VIRGINIA VARIOUS LOCATIONS AS INDICATED BY ORDER	
No City US	WV	No City US	WV

Line	Comm Ln Desc	Qty	Unit Issue	Unit Price	Total Price
46	9" X 28" EMERGENCY RESPONSE TRAILER ROUTE OVERLAY PLAQUE FO	1.00000	EA	17.78	17.78

Comm Code	Manufacturer	Specification	Model #
55120000	Dicke Tool		FPO928PNK

Extended Description:

9" X 28" EMERGENCY RESPONSE TRAILER ROUTE OVERLAY PLAQUE FOR ITEM 51, fluorescent-pink (SPECIFY EACH INDIVIDUAL ROUTE PLAQUE TO BE SUPPLIED AND QTY OF EACH)

INVOICE TO		SHIP TO	
VARIOUS AGENCY LOCATIONS AS INDICATED BY ORDER		STATE OF WEST VIRGINIA VARIOUS LOCATIONS AS INDICATED BY ORDER	
No City US	WW	No City US	WW

Line	Comm Ln Desc	Qty	Unit Issue	Unit Price	Total Price
47	9" X 7" EMERGENCY RESPONSE TRAILER CARDINAL DIRECTION OVERL	1.00000	EA	17.78	17.78

Comm Code	Manufacturer	Specification	Model #
55120000	Dicke Tool		FPO716PNK

Extended Description:
 9" X 7" EMERGENCY RESPONSE TRAILER CARDINAL DIRECTION OVERLAY PLAQUE FOR ITEM 51, fluorescent-pink
 (SPECIFY QTY OF EACH "N", "S", "E", AND "W" PLAQUES TO BE SUPPLIED)

INVOICE TO		SHIP TO	
VARIOUS AGENCY LOCATIONS AS INDICATED BY ORDER		STATE OF WEST VIRGINIA VARIOUS LOCATIONS AS INDICATED BY ORDER	
No City US	WW	No City US	WW

Line	Comm Ln Desc	Qty	Unit Issue	Unit Price	Total Price
48	48" x 48" DIAMOND, FLUORESCENT PINK, STANDARD MESSAGE ROLL-	1.00000	EA	92.23	92.23

Comm Code	Manufacturer	Specification	Model #
55120000	Dicke Tool		RUR48PNKSIGN

Extended Description:
 48" x 48" DIAMOND, FLUORESCENT PINK, STANDARD MESSAGE ROLL-UP SIGN (SPECIFY QUANTITY OF EACH
 FABRICATION NUMBER TO BE SUPPLIED)

INVOICE TO		SHIP TO	
VARIOUS AGENCY LOCATIONS AS INDICATED BY ORDER		STATE OF WEST VIRGINIA VARIOUS LOCATIONS AS INDICATED BY ORDER	
No City US	WW	No City US	WW

Line	Comm Ln Desc	Qty	Unit Issue	Unit Price	Total Price
49	36" x 36" DIAMOND, FLUORESCENT PINK, STANDARD MESSAGE ROLL-U	1.00000	EA	64.34	64.34

Comm Code	Manufacturer	Specification	Model #
55120000	Dicke Tool		RUR36PNKSIGN

Extended Description:
 36" x 36" DIAMOND, FLUORESCENT PINK, STANDARD MESSAGE ROLL-UP SIGN (SPECIFY QUANTITY OF EACH FABRICATION NUMBER TO BE SUPPLIED)

INVOICE TO		SHIP TO	
VARIOUS AGENCY LOCATIONS AS INDICATED BY ORDER		STATE OF WEST VIRGINIA VARIOUS LOCATIONS AS INDICATED BY ORDER	
No City US	WW	No City US	WW

Line	Comm Ln Desc	Qty	Unit Issue	Unit Price	Total Price
50	48" x 48" DIAMOND, FLUORESCENT PINK, STANDARD MESSAGE ROLL-	1.00000	EA	96.04	96.04

Comm Code	Manufacturer	Specification	Model #
55120000	Dicke Tool		RUR48PNKSIGN

Extended Description:
 48" x 48" DIAMOND, FLUORESCENT PINK, STANDARD MESSAGE ROLL-UP SIGN WITH HOOK & LOOP STRIPS FOR OVERLAY ATTACHMENTS (SPECIFY QTY OF EACH FABRICATION NUMBER TO BE SUPPLIED AND PORTION OF TEXT INTENDED TO BE COVERED WITH OVERLAY PLAQUES - ORDER OVERLAY PLAQUES UNDER BID ITEM 52)

INVOICE TO		SHIP TO	
VARIOUS AGENCY LOCATIONS AS INDICATED BY ORDER		STATE OF WEST VIRGINIA VARIOUS LOCATIONS AS INDICATED BY ORDER	
No City US	WW	No City US	WW

Line	Comm Ln Desc	Qty	Unit Issue	Unit Price	Total Price
51	36" x 36" DIAMOND, FLUORESCENT PINK, STANDARD MESSAGE ROLL-	1.00000	EA	68.15	68.15

Comm Code	Manufacturer	Specification	Model #
55120000	Dicke Tool		RUR36PNKSIGN

Extended Description:

36" x 36" DIAMOND, FLUORESCENT PINK, STANDARD MESSAGE ROLL-UP SIGN WITH HOOK & LOOP STRIPS FOR OVERLAY ATTACHMENTS (SPECIFY QTY OF EACH FABRICATION NUMBER TO BE SUPPLIED AND PORTION OF TEXT INTENDED TO BE COVERED WITH OVERLAY PLAQUES - ORDER OVERLAY PLAQUES UNDER BID ITEM 53)

INVOICE TO		SHIP TO	
VARIOUS AGENCY LOCATIONS AS INDICATED BY ORDER		STATE OF WEST VIRGINIA VARIOUS LOCATIONS AS INDICATED BY ORDER	
No City US	WW	No City US	WW

Line	Comm Ln Desc	Qty	Unit Issue	Unit Price	Total Price
52	8" X 21" ("LEFT" AND "CENTER" TEXT ONLY) OR 8" x 28" FLUORES	1.00000	EA	17.78	17.78

Comm Code	Manufacturer	Specification	Model #
55120000	Dicke Tool		FPO822PNK

Extended Description:

8" X 21" ("LEFT" AND "CENTER" TEXT ONLY) OR 8" x 28" FLUORESCENT PINK OVERLAYS WITH H&L STRIPS FOR USE WITH ITEM NUMBER 50. EXAMPLES: LEFT, 500 FT., 1000 FT., 1500 FT., 1/2 MILE, AND 1 MILE (SPECIFY QUANTITY OF EACH PLAQUE TO BE SUPPLIED)

INVOICE TO	SHIP TO
-------------------	----------------

VARIOUS AGENCY LOCATIONS AS INDICATED BY ORDER No City WW US	STATE OF WEST VIRGINIA VARIOUS LOCATIONS AS INDICATED BY ORDER No City WW US
--	--

Line	Comm Ln Desc	Qty	Unit Issue	Unit Price	Total Price
53	6" x 21" FLUORESCENT PINK OVERLAYS WITH H&L STRIPS FOR USE	1.00000	EA	17.78	17.78

Comm Code	Manufacturer	Specification	Model #
55120000	Dicke Tool		FPO621PNK

Extended Description:
 6" x 21" FLUORESCENT PINK OVERLAYS WITH H&L STRIPS FOR USE WITH ITEM NUMBER 53. EXAMPLES: LEFT, 500 FT., 1000 FT., 1500 FT., 1/2 MILE, 1 MILE, and AHEAD (SPECIFY QUANTITY OF EACH PLAQUE TO BE SUPPLIED)

SCHEDULE OF EVENTS

<u>Line</u>	<u>Event</u>	<u>Event Date</u>
1	Tech Questions due by 10:00am	2024-03-14

	Document Phase	Document Description	Page 29
DOT2400000081	Final	REFLECTIVE ROLL-UP SIGNS	

ADDITIONAL TERMS AND CONDITIONS

See attached document(s) for additional Terms and Conditions

REQUEST FOR QUOTATION
Reflective Roll-Up Signs

SPECIFICATIONS

- 1. PURPOSE AND SCOPE:** The West Virginia Purchasing Division is soliciting bids on behalf of the West Virginia Division of Highways to establish an open-end contract for Reflective Roll-Up Signs.

- 2. DEFINITIONS:** The terms listed below shall have the meanings assigned to them below. Additional definitions can be found in section 2 of the General Terms and Conditions.
 - 2.1 “Contract Item” or “Contract Items”** means the list of items identified in Section 3, Subsection 1 below.

 - 2.2 “Pricing Pages”** means the schedule of prices, estimated order quantity, and totals contained in wvOASIS or attached hereto as Exhibit A and used to evaluate the Solicitation response.

 - 2.3 “Solicitation”** means the official notice of an opportunity to supply the State with goods or services that is published by the Purchasing Division

 - 2.4 “RFQ”** means the official request for quotation published by the Purchasing Division.

 - 2.5 “WVDOH”** means West Virginia Department of Highways.

 - 2.6 “NCHRP-350”** means National Cooperative Highway Research Program Report 350.

 - 2.7 “AASHTO”** means American Association of State and Highway Transportation Officials.

 - 2.8 “MPH”** means Miles Per Hour.

 - 2.9 “MASH”** means the AASHTO Manual for Assessing Safety Hardware, latest edition.

 - 2.10 “P.V.C.”** means Polyvinyl Chloride.

 - 2.11 “H&L”** means Hook & Loop.

 - 2.12 “OZ”** means Ounce.

REQUEST FOR QUOTATION
Reflective Roll-Up Signs

2.13 “SQ” means Square.

2.14 “YD” means Yard.

2.15 “LB” means Pound.

2.16 “MIN” means Minimum.

2.17 “EA” means Each.

2.18 “ASTM” means American Society for Testing and Materials.

2.19 “FHWA” means Federal Highway Administration”

2.20 “ASTM D4956” means the ASTM specification titled “Standard Specification for Retroreflective Sheeting for Traffic Control”. An internet link to this specification is as follows:

<https://www.astm.org/Standards/D4956.htm>

2.21 “MUTCD” means the FHWA publication “Manual on Uniform Traffic Control Devices, 2009 Edition. An internet link to this publication is as follows:

<https://mutcd.fhwa.dot.gov/pdfs/2009r1r2/mutcd2009r1r2edition.pdf>

2.22 “Standard Specifications” means the 2023 Edition of the Standard Specifications Roads and Bridges, as well as the 2024 Supplemental Specifications to accompany the 2023 Edition of the Standard Specifications Roads and Bridges. An internet link to each of these publications is as follows:

<https://transportation.wv.gov/highways/TechnicalSupport/specifications/Pages/default.aspx>

2.23 “WVDOH Sign Fabrication Details” means the manual “WVDOH Sign Fabrication Details, Traffic Engineering Division, September 2005, latest printing. An Internet link to this manual is as follows:

<http://www.transportation.wv.gov/highways/engineering/Manuals/Traffic/SIGNFAB/INDEX.pdf>

2.24 “Retroreflective Sign Sheeting APL” means the version of the WVDOH Approved Products list for Retroreflective Sign Sheeting in effect as of the

REQUEST FOR QUOTATION
Reflective Roll-Up Signs

advertising date of this Contract. This APL may be found at: [http://transportation.wv.gov/highways/mcst/Pages/APL By Number.aspx](http://transportation.wv.gov/highways/mcst/Pages/APL%20By%20Number.aspx)

The APL is established in a manner consistent with the requirements contained in the Standard Specifications. All retroreflective sheeting applied to products supplied under this Contract shall be an approved type ASTM-VI material. The APL establishes a list of products that meet the acceptable level of quality and is not intended to reflect a preference or favor any particular brand or vendor. Any manufacturer whose product(s) meet the established level of quality may become an approved supplier and have their product(s) added to the APL in accordance with the approval procedures described in the Standard Specifications.

2. GENERAL REQUIREMENTS:

3.1 Contract Items and Mandatory Requirements: Vendor shall provide Agency with the Contract Items listed below on an open-end and continuing basis. Contract Items must meet or exceed the mandatory requirements as shown below.

The specifications of this RFQ and/or any WVDOH Standards referenced in and/or attached to this RFQ may include references to specific recognized "industry standard" specifications which are issued by third parties, such as the American Society for Testing and Materials (ASTM) and the American Association of State and Highway Transportation Officials (AASHTO). Such specifications are protected by strict copyright restrictions and cannot be published as part of this RFQ. The ability to access such specifications shall be considered a mandatory requirement for participation in the RFQ process as a Vendor or as a supplier to the Vendor, as applicable.

3.2 Roll Up Signs

3.2.1 Roll-Up Sign Sheeting

All signs and plaques supplied as part of this Contract shall be manufactured using Type ASTM-VI sheeting from the WVDOH Approved Products list for Retroreflective Sign Sheeting.

All fluorescent-pink signs and plaques supplied under this Contract shall be manufactured using a sheeting meeting the Type VI material requirements contained within ASTM D4956, latest version. The sheeting used shall be provided by a manufacturer

REQUEST FOR QUOTATION
Reflective Roll-Up Signs

whose fluorescent-orange Type ASTM-VI material is listed on the WVDOH APL for Retroreflective Sign Sheeting.

3.2.2 Roll-Up Sheeting Splices

In cases where the splicing of roll-up sign material fabric is required as noted herein, the splice shall be accomplished by the following method.

- The seam shall be continuously “bridged” on the back side of the sign by a 4” (minimum) wide strip of 18oz Cooley or equal fabric coated with 200mp adhesive.
- The seam shall be stitched on both the front and back faces of the sign.
- The seam shall be bar tacked on both the front and back faces of the sign on each end of the seam.

3.2.3 Sign Fabrication Specifications

All signs supplied shall have one or more vertical fiberglass ribs, with at least one along the vertical centerline of the sign, unless specified otherwise.

All vertical, horizontal, or diagonal ribs shall be designed to pivot about a metallic pivot point. The metallic pivot point shall be a low profile 3/8” diameter, zinc plated steel tubular rivet. Ribs shall be separated by zinc plated flat washers to allow collapsing and roll up of the sign. The rivet shall be equal to Allied Tubular Rivet Inc.’s Part No. 6503. The flat washers shall also eliminate any slack in the assembly while still allowing rotation of the cross braces.

All signs shall be furnished with fabric corner pockets that are accurately placed so that when the sign is assembled with the cross bracing the fit maintains a taut professional look that does not bow or sag. The pockets shall be made from a 15 oz./sq. yd. min. woven fabric with yarn .018 min. in diameter that consists of approximately 80% P.V.C. and 20% polyester thread, yielding a minimum of 52 total threads per square inch. The material is finished with heat and pressure in such a way to stabilize the fabric against excess stretch and provide adequate seam strength. The ASTM D3787 ball burst strength should be at least 320 lbs.

REQUEST FOR QUOTATION
Reflective Roll-Up Signs

Pockets must be triangular in shape [or rectangular as required for ribs that require pockets but are not installed in a sign corner forming a 90 degree angle] and consist of 2 independent square pieces that are folded to form an isosceles triangle and sewn together making it 4 ply. The piece that is in contact with the back of the sign shall be either 9x9 or 7x7 (see table below) and the top piece that creates the pocket cavity shall be an 8x8 or 6x6 respectively. The two pieces are sewn together with an exterior grade T-80H min. tex. size cotton warp thread around the perimeter except for an area for the pocket cavity that is 2x4-1/4 and 2x2-3/4 in the center of the triangle. All thread shall be orange in color for orange background signs, pink in color for pink background signs, and white in color for all other signs. Two vertical 5/8" long bar tacks are to be sewn at the rib entry and one at the pressure point at the end of the pocket using T-40 min. tex. size polyester/cotton corespun thread. The pocket is sewn to the sign following a path around its perimeter with the T-80H thread providing distribution of the rib tension over a significant area instead of along the corner-to-corner centerline. The edges of the pocket cavity must be parallel to the corner-to-corner axis of the cross braces and the end of the pocket that makes contact with the brace tip must be perpendicular to that axis. Detail drawings are provided below for the 9x9 pocket (Type B) and the 7x7 pocket (Type A).

Rectangular pockets, when required, shall be 2-1/2" wide mesh (see table below), and of sufficient length when folded to form 4 layers of mesh at least 3/4" back from the end of the cross brace and 3 layers on the remaining part of the pocket. The bar tacks shall be 1/2" long minimum up to 5/8" long. Pockets shall be orange in color for orange background signs and white in color for all other signs.

Pockets shall be installed as close as possible to the edges of the sign. The sewing operation, including but not limited to thread size, equipment, etc. shall be determined and accomplished to not damage the reflective sheeting while providing a product conforming to these specifications.

REQUEST FOR QUOTATION
Reflective Roll-Up Signs

SIGN SHAPE	POCKET SIZE
48" Diamond	9x9 (Pocket B)
36" Diamond	7x7 (Pocket A)
60x60 Square	9x9 (Pocket B)
48x48 Square	9x9 (Pocket B)
36x48 vert rectangle	9x9 (Pocket B)
36x60 vert rectangle	9x9 (Pocket B)
24x30 vert rectangle	7x7 (Pocket A)
60x30 horiz rectangle	9x9 (Pocket B)
48x36 horiz rectangle	7x7 (Pocket A)
48x30 horiz rectangle	7x7 (Pocket A)
48x24 horiz rectangle	7x7 (Pocket A)
30x24 horiz rectangle	7x7 (Pocket A)
30x18 horiz rectangle	7x7 (Pocket A)
36" octagon	2-1/2W x 2-1/4L rectangular (horizontal rib) 2-1/2W x 3-1/4L rectangular (vertical ribs)
48" octagon	2-1/2W x 2-1/4L rectangular (horizontal rib) 2-1/2W x 3-1/4L rectangular (vertical ribs)
36" triangle	2-1/2W x 2-1/4L rectangular
48" triangle	2-1/2W x 3-1/4L rectangular

With the exception of octagonal (Stop) and triangular (Yield) signs, two pieces of H&L shall be sewn on all non-diamond signs for attachment of the sign to the vertical rib. The H&L shall have sufficient length to encircle the vertical rib and hold the sign taut to the rib. The locations of the two pieces of H&L shall be 2" from the bottom and 2" from the top of the sign to the beginning edge of the H&L and on the sign's vertical centerline. Half of the length shall be hook type and other half shall be loop type with the two types reversed and sewn together and then to the back of the sign.

For the vertical rib of triangular (Yield) signs, only the bottom piece of H&L described above shall be required. In addition, a 3" long piece of H&L shall be attached via adhesive to the side of the rib not touching the back of the sign to allow the rib to be held in position via attachment to the H&L attached to the back sign face.

REQUEST FOR QUOTATION
Reflective Roll-Up Signs

All vertical ribs of octagonal (stop) signs shall be installed in rectangular pockets. The rectangular pockets for the horizontal rib shall be installed directly under the outside vertical ribs of the sign.

REQUEST FOR QUOTATION
Reflective Roll-Up Signs

CLOTH CORNER POCKET DESIGNS

TYPE A POCKET DESIGN

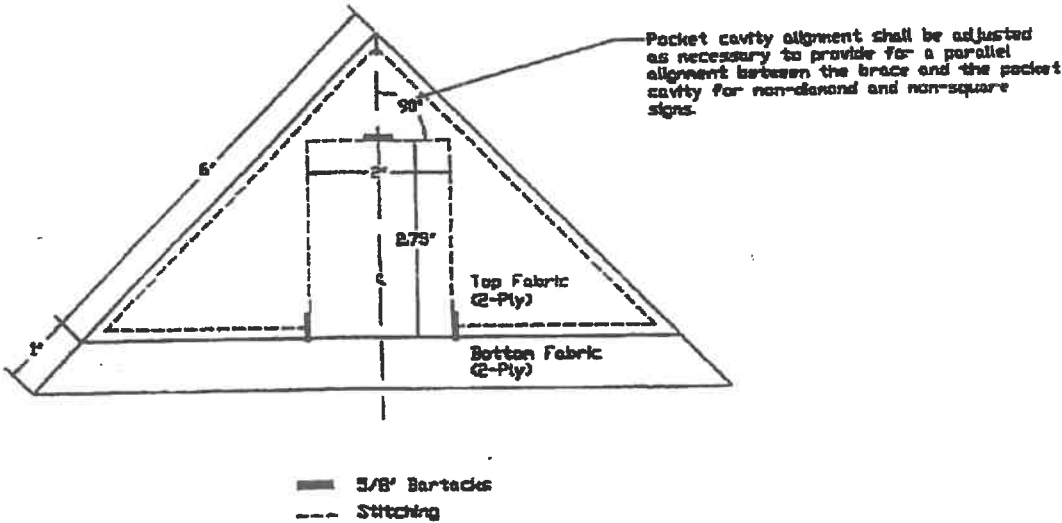

TYPE B POCKET DESIGN

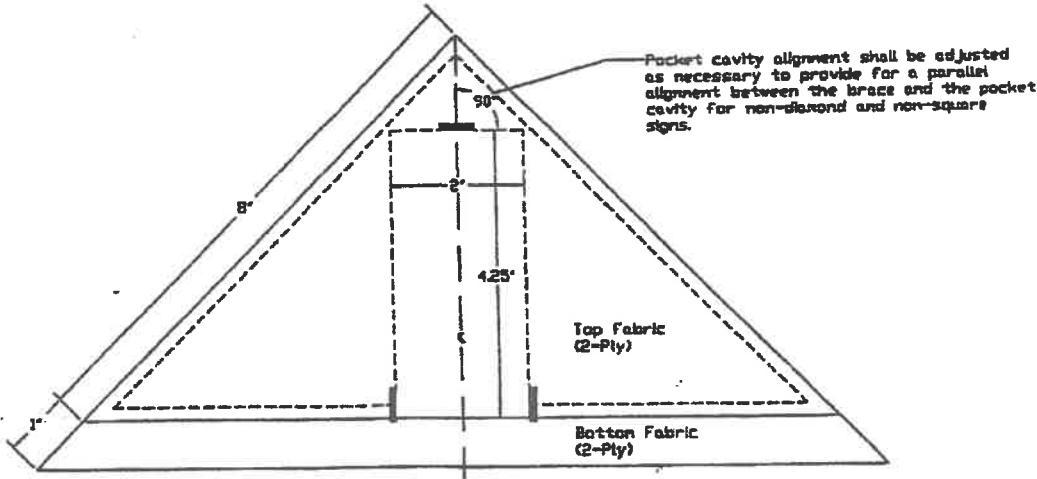

REQUEST FOR QUOTATION Reflective Roll-Up Signs

When specified as part of the item description, two 18" x 18" non-reflective fluorescent orange vinyl flags shall be permanently attached to the top of the vertical rib that is along the vertical centerline of the sign. The system for deploying the flags shall be a good quality, long lasting, reliable system. All metal parts of the system shall be stainless steel, electro-deposit zinc coated steel, hot-dip galvanized steel, or powder coated steel. Flag staffs shall be 1/8" thick x 1" wide fiberglass ribs. The staffs shall be sufficiently long enough to hold the flags completely above the sign face. No hand tightening of any components shall be required to hold the flags in the deployed position. When deployed, the two flags shall extend symmetrically (about the vertical centerline) up and out from their mounting point along the vertical rib, with the flags held in position completely above the sign face, and with each staff at an angle of 30 to 60 degrees from the vertical centerline of the sign. Staff mounting and deployment systems shall be subject to review and approval.

For particular signs (see bid item listing) and all overlay plaques requiring H&L strips for temporary overlay attachment, the hook ("coarse") side of the H&L shall be attached to the sign faces. The loop ("fuzzy") side of the H&L shall be attached to the back face of the overlays.

All signs must present a finished, professional look to the motorist with no sagging of the sign material. Signs shall include anti-kite H&L loops attached to the back faces of the signs and to be connected around the ribs of the signs. The sign manufacturer shall determine appropriate locations for anti-kite H&L strips unless otherwise specified herein. An additional length of H&L material shall be fastened near the vertical center of one of the horizontal end points on each sign, and shall be oriented such that when the sign is rolled up on the vertical rib the H&L material will encircle the sign and hold it in the rolled up storing position.

All roll-up signs shall have a permanent sticker affixed to the non-reflective face with the wording "PROPERTY OF WVDOH" in 1/2" minimum legend size.

Identification shall be printed in the margin for convenient indication of the sign message when the sign is rolled up for storage.

The WVDOH reserves the right to and will consider manufacturer proposed adjustments to the rib sizes, rib locations, rib lengths, corner pocket locations, splice locations, and rib rotation points specified herein for each item. Such requests shall be submitted by the manufacturer in writing after award of the

REQUEST FOR QUOTATION
Reflective Roll-Up Signs

Contract. No acceptance of such requests are implied or guaranteed by the WVDOH.

By bidding this Contract, the Vendor agrees to extend to the WVDOH a one (1) year warranty against defects in workmanship, parts, and materials on all signs supplied as part of this Contract. Sheeting performance failure shall be covered by the approved sheeting manufacturer's warranty provided to the WVDOH, as applicable.

Within the following description of bid items, there are numerous diamond sign items (31, 32, 33, 34, 50, & 51) for which alternate messages may be displayed using supplemental overlay plaques. All such signs are to be ordered/manufactured with a "base" message in accordance with Exhibit HH. The "base" message is the permanent word, numeral, or phrase that is to be printed on the sign face. Alternate messages will be accomplished using the supplemental overlay plaques.

3.2.4 Item 1 - 36" R1-1F "STOP" SIGN

Signs supplied as part of Bid Item 1 shall be per the WVDOH Sign Fabrication Details, fabrication number R1-1, 36", and shall be octagonal in shape. Rib sizes, rib locations, rib lengths, corner pocket locations, and rotation point location shall be in substantial conformance as shown in the attached drawing (Exhibit C) "36" OCTAGON – CORNER POCKET AND RIB CONFIGURATION".

3.2.5 Item 2 – 48" R1-1F "STOP" SIGN

Signs supplied as part of Bid Item 2 shall be per the WVDOH Sign Fabrication Details, fabrication number R1-1, 48", and shall be octagonal in shape. Rib sizes, rib locations, rib lengths, corner pocket locations, and rotation point location shall be in substantial conformance as shown in the attached drawing (Exhibit D) "48" OCTAGON – CORNER POCKET AND RIB CONFIGURATION".

3.2.6 Item 3 – 36" W3-1MF SYMBOLIC "STOP AHEAD" SIGN

Signs supplied as part of Bid Item 3 shall be per the WVDOH Sign Fabrication Details, fabrication number W3-1M, 36". An orange background shall be used. The symbol may be glued or sewn onto the sign face separately. Rib sizes, rib locations, rib lengths, corner pocket locations, and rotation point location shall be in substantial conformance as shown in the attached drawing (Exhibit E) "36" DIAMOND – CORNER POCKET AND RIB CONFIGURATION".

3.2.7 Item 4 – 48" W3-1MF SYMBOLIC "STOP AHEAD" SIGN

Signs supplied as part of Bid Item 4 shall be per the WVDOH Sign Fabrication Details, fabrication number W3-1M, 48". An orange background shall be used. The symbol may be glued or sewn onto the sign face separately. Rib sizes, rib locations, rib lengths, corner

REQUEST FOR QUOTATION
Reflective Roll-Up Signs

pocket locations, and rotation point location shall be in substantial conformance as shown in the attached drawing (Exhibit F) **"48" DIAMOND – CORNER POCKET AND RIB CONFIGURATION"**.

3.2.8 Item 5 – 36" R1-2F "YIELD" SIGN

Signs supplied as part of Bid Item 5 shall be per the WVDOH Sign Fabrication Details, fabrication number R1-2, 36", and shall be triangular in shape. Rib sizes, rib locations, rib lengths, corner pocket locations, and rotation point location shall be in substantial conformance as shown in the attached drawing (Exhibit G) **"36" TRIANGLE – CORNER POCKET AND RIB CONFIGURATION"**.

3.2.9 Item 6 – 48" R1-2F "YIELD" SIGN

Signs supplied as part of Bid Item 6 shall be per the WVDOH Sign Fabrication Details, fabrication number R1-2, 48", and shall be triangular in shape. Rib sizes, rib locations, rib lengths, corner pocket locations, and rotation point location shall be in substantial conformance as shown in the attached drawing (Exhibit H) **"48" TRIANGLE – CORNER POCKET AND RIB CONFIGURATION"**.

3.2.10 Item 7 – 36" W3-2MF SYMBOLIC "YIELD AHEAD" SIGN

Signs supplied as part of Bid Item 7 shall be per the WVDOH Sign Fabrication Details, fabrication number W3-2M, 36". An orange background shall be used. The symbol may be glued or sewn onto the sign face separately. Rib sizes, rib locations, rib lengths, corner pocket locations, and rotation point location shall be in substantial conformance as shown in the attached drawing (Exhibit E) **"36" DIAMOND – CORNER POCKET AND RIB CONFIGURATION"**.

3.2.11 Item 8 – 48" W3-2MF SYMBOLIC "YIELD AHEAD" SIGN

Signs supplied as part of Bid Item 8 shall be per the WVDOH Sign Fabrication Details, fabrication number W3-2M, 48". An orange background shall be used. The symbol may be glued or sewn onto the sign face separately. Rib sizes, rib locations, rib lengths, corner pocket locations, and rotation point location shall be in substantial conformance as shown in the attached drawing (Exhibit F) **"48" DIAMOND – CORNER POCKET AND RIB CONFIGURATION"**.

**3.2.12 Item 9 – 36"x60" R2-1MF "WORK ZONE SPEED LIMIT
" with hook & loop for numeral overlay plaques**

Signs supplied as part of Bid Item 9 shall be per the attached drawing **"BID ITEM 9 MODIFIED STANDARD DETAIL"** (Exhibit I). Overall size shall be 36"x60". All text shall be black. The background above the horizontal border shall be orange. The background below the horizontal border shall be white. The seam between the upper (orange background) and bottom (white background) portions of the sign shall be sewn along the black border in the manner specified above in Section 3.2.2. No numerals shall be screened onto the sign face. 2 ea. 28" long x 1" (min) wide pieces of H&L shall be glued or sewn onto the sign face, as shown on the attached modified standard detail, to facilitate the attachment of the interchangeable numerals to be supplied as part of Bid Item

REQUEST FOR QUOTATION
Reflective Roll-Up Signs

10. Rib sizes, rib locations, rib lengths, corner pocket locations, and rotation point location shall be in substantial conformance as shown in the attached drawing (Exhibit J) “**36X60 VERTICAL RECTANGLE – CORNER POCKET AND RIB CONFIGURATION**”.

3.2.13 Item 10 – 14”x17” NUMERAL OVERLAY PLAQUES FOR ITEM #9

Items supplied as part of Bid Item 10 shall be individual numeral plaques intended to be attached to the face of signs supplied under Bid Item 9. The numeral portions of the plaques shall be black, and the background portions shall be white. The overall size of each individual plaque shall be 17” tall x 14” wide. Numerals shall be 15” Series E, and shall be centered vertically and horizontally in each plaque. 2 ea. 14” long x 1” (min) wide pieces of H&L shall be glued or sewn onto the back face of each plaque, with 1 ea. of the pieces along the top and bottom edges of the plaque, and with the outside edge of each piece along the outside edge of the plaque. Orders will specify the quantity of each individual numeral to be supplied.

3.2.14 Item 11 – 48”x24” R4-14(L/R)F “ALL TRAFFIC (WITH INTERCHANGEABLE ARROW HEAD)”

Signs supplied as part of Bid Item 11 shall be per the attached drawing “**BID ITEM 11 MODIFIED STANDARD DETAIL**” (Exhibit K). The text, arrow shaft, and border portions of the sign shall be black, and the background portion shall be white. 4 ea. 8” long x 1” (min) wide pieces of white H&L shall be glued or sewn onto the sign face, as shown on the attached detail, to facilitate the attachment of the included detachable arrow head as described below. Rib sizes, rib locations, rib lengths, corner pocket locations, and rotation point location shall be in substantial conformance as shown in the attached drawing (Exhibit L) “**48X24 HORIZONTAL RECTANGLE – CORNER POCKET AND RIB CONFIGURATION**”.

With each of the signs supplied as part of this bid item, 1 ea. separate arrow head plaque, intended to be attached to the face of the sign, shall be supplied as detailed on the above referenced modified standard detail. 2 ea. 8” long x 1” (min) wide pieces of H&L shall be glued or sewn onto the back face of each plaque, with 1 ea. of the pieces along the top and bottom edges of the plaque, and with the outside edge of each piece along the outside edge of the plaque. The arrow head and shaft portions of the plaque shall be black, and the background portion shall be white.

3.2.15 Item 12 – 24”x30” R4-7BF “KEEP RIGHT” SIGN

Signs supplied as part of Bid Item 12 shall be per the WVDOH Sign Fabrication Details, fabrication number R4-7B, 24”X30”. Rib sizes, rib locations, rib lengths, corner pocket locations, and rotation point location shall be in substantial conformance as shown in the attached drawing (Exhibit M) “**24X30 VERTICAL RECTANGLE – CORNER POCKET AND RIB CONFIGURATION**”.

3.2.16 Item 13 – 36”x48” R4-7BF “KEEP RIGHT” SIGN

Signs supplied as part of Bid Item 13 shall be per the WVDOH Sign Fabrication Details, fabrication number R4-7B, 36”X48”. Rib sizes, rib locations, rib lengths, corner pocket

REQUEST FOR QUOTATION
Reflective Roll-Up Signs

locations, and rotation point location shall be in substantial conformance as shown in the attached drawing (Exhibit N) “36X48 VERTICAL RECTANGLE – CORNER POCKET AND RIB CONFIGURATION”.

3.2.17 Item 14 – 30”x18” R9-9F “SIDEWALK CLOSED”

Signs supplied as part of Bid Item 14 shall be per the WVDOH Sign Fabrication Details, fabrication number R9-9. Rib sizes, rib locations, rib lengths, corner pocket locations, and rotation point location shall be in substantial conformance as shown in the attached drawing (Exhibit O) “30X18 HORIZONTAL RECTANGLE – CORNER POCKET AND RIB CONFIGURATION”.

3.2.18 Item 15 – 48”x30” R11-2F “ROAD CLOSED” WITH HOOK & LOOP FOR OVERLAY PLAQUES

Signs supplied as part of Bid Item 15 shall be per the attached drawing “BID ITEM 15 MODIFIED STANDARD DETAIL” (Exhibit P). The text and border portions of the sign shall be black, and the background portion shall be white. 2 ea. 39” long x 1” wide pieces of white H&L shall be glued or sewn onto the sign face, as shown on the attached modified standard detail, to facilitate the attachment of the interchangeable “BRIDGE” and “RAMP” plaques to be supplied as part of Bid Item 16. Rib sizes, rib locations, rib lengths, corner pocket locations, and rotation point location shall be in substantial conformance as shown in the attached drawing (Exhibit Q) “48x30 HORIZONTAL RECTANGLE – CORNER POCKET AND RIB CONFIGURATION”.

3.2.19 Item 16 – 10”x39” “BRIDGE” AND “RAMP” OVERLAY PLAQUES FOR ITEM #15

Items supplied as part of Bid Item 16 shall be individual message “BRIDGE” and “RAMP” plaques intended to be attached to the face of signs supplied under Bid Item 15. The text portions of the plaques shall be black, and the background portions shall be white. The overall size of each individual plaque shall be 10” tall x 39” wide. Text shall be 8” Series D, and shall be centered vertically and horizontally in each plaque. 2 ea. 39” long x 1” wide pieces of H&L shall be glued or sewn onto the back face of each plaque, with 1 ea. of the pieces along the top and bottom edges of the plaque, and with the outside edge of each piece along the outside edge of the plaque. Orders will specify the quantity of each individual message (“BRIDGE” and “RAMP”) to be supplied.

3.2.20 Item 17 – 60”x30” R11-3AF “ROAD CLOSED ____ MI AHEAD LOCAL TRAFFIC ONLY” WITH HOOK & LOOP FOR NUMERAL OVERLAY PLAQUES

Signs supplied as part of Bid Item 17 shall be per the attached drawing “BID ITEM 17 MODIFIED STANDARD DETAIL” (Exhibit R). The text and border portions of the sign shall be black, and the background portion shall be white. No numerals shall be screened onto the sign face. 2 ea. 10” long x 1” (min) wide pieces of white H&L shall be glued or sewn onto the sign face, as shown on the attached modified standard detail, to facilitate the attachment of the interchangeable numeral plaques to be supplied as part of Bid Item 18. Rib sizes, rib locations, rib lengths, corner pocket locations, and rotation point location shall be in substantial conformance as shown in the attached drawing

REQUEST FOR QUOTATION
Reflective Roll-Up Signs

(Exhibit S) “60x30 HORIZONTAL RECTANGLE – CORNER POCKET AND RIB CONFIGURATION”.

3.2.21 Item 18 – 5”x7” NUMERAL OVERLAY PLAQUES FOR ITEM #17

Items supplied as part of Bid Item 18 shall be individual numeral plaques intended to be attached to the face of signs supplied under Bid Item 17. The numeral portions of the plaques shall be black, and the background portions shall be white. The overall size of each individual plaque shall be 7” tall x 5” wide. Numerals shall be 5” Series C, and shall be centered vertically and horizontally in each plaque. 2 ea. 5” long x 1” (min) wide pieces of H&L shall be glued or sewn onto the back face of each plaque, with 1 ea. of the pieces along the top and bottom edges of the plaque, and with the outside edge of each piece along the outside edge of the plaque. Orders will specify the quantity of each individual numeral to be supplied.

3.2.22 Item 19 – 60”x30” R11-4F “ROAD CLOSED TO THRU TRAFFIC”

Signs supplied as part of Bid Item 19 shall be per the WVDOH Sign Fabrication Details, fabrication number R11-4. Rib sizes, rib locations, rib lengths, corner pocket locations, and rotation point location shall be in substantial conformance as shown in the attached drawing (Exhibit S) “60x30 HORIZONTAL RECTANGLE – CORNER POCKET AND RIB CONFIGURATION”.

3.2.23 Item 20 – 48”x36” W22-10F “EXIT _____” WITH HOOK & LOOP FOR OVERLAYS

Signs supplied as part of Bid Item 20 shall be per the attached drawing “BID ITEM 20 MODIFIED STANDARD DETAIL” (Exhibit T). The text and border portions of the sign shall be black, and the background portion shall be orange. 2 ea. 40” long x 1” (min) wide pieces of H&L shall be glued or sewn onto the sign face, as shown on the attached modified standard detail, to facilitate the attachment of the interchangeable message plaques to be supplied as part of Bid Item 21. Rib sizes, rib locations, rib lengths, corner pocket locations, and rotation point location shall be in substantial conformance as shown in the attached drawing (Exhibit U) “48x36 HORIZONTAL RECTANGLE – CORNER POCKET AND RIB CONFIGURATION”.

3.2.24 Item 21 – 10”x40” “OPEN” AND “CLOSED” OVERLAY PLAQUES FOR ITEM #20

Items supplied as part of Bid Item 21 shall be individual message plaques intended to be attached to the face of signs supplied under Bid Item 20. The text portions of the plaques shall be black, and the background portions shall be orange. The overall size of each individual plaque shall be 10” tall x 40” wide. Text shall be 8” Series D, and shall be centered vertically and horizontally in each plaque. 2 ea. 40” long x 1” (min) wide pieces of H&L shall be glued or sewn onto the back face of each plaque, with 1 ea. of the pieces along the top and bottom edges of the plaque, and with the outside edge of each piece along the outside edge of the plaque. Orders will specify the quantity of each individual message (“OPEN” and “CLOSED”) to be supplied.

REQUEST FOR QUOTATION
Reflective Roll-Up Signs

3.2.25 Item 22 – 60”x60” W22-11F EXIT GORE SIGN

Signs supplied as part of Bid Item 22 shall be per the WVDOH Sign Fabrication Details, fabrication number W22-11. The text and border portions of the sign shall be black, and the background portion of the sign shall be orange. One vertical seam located 12” from the left (front face) edge of the sign will be allowed. The seam shall be manufactured in the manner specified above in Section 3.2.2. Rib sizes, rib locations, rib lengths, corner pocket locations, and rotation point location shall be in substantial conformance as shown in the attached drawing (Exhibit V) “60X60 SQUARE – CORNER POCKET AND RIB CONFIGURATION”.

3.2.26 Item 23 – 30”x24” M4-9F STANDARD DETOUR SIGN WITH HOOK & LOOP AND ARROW OVERLAY PLAQUE

Signs supplied as part of Bid Item 23 shall be per the attached drawing (Exhibit W) “**BID ITEM 23 MODIFIED STANDARD DETAIL**”. The text and border portions of the sign shall be black, and the background portion shall be orange. 4 ea. 5” long x ½” wide pieces of H&L shall be glued or sewn onto the sign face, as shown on the attached modified standard detail, to facilitate the attachment of the arrow overlay plaque as described below. Rib sizes, rib locations, rib lengths, corner pocket locations, and rotation point location shall be in substantial conformance as shown in the attached drawing (Exhibit Y) “**30X24 HORIZONTAL RECTANGLE – CORNER POCKET AND RIB CONFIGURATION**”.

With each of the signs supplied as part of this bid item, 1 ea. separate arrow head plaque, intended to be attached to the face of the sign as detailed on the above referenced modified standard detail (Exhibit X), shall be supplied. 8 ea. 5” long x ½” wide pieces of H&L shall be glued or sewn onto the back face of each plaque as shown on the modified standard detail. The arrow head and shaft portions of the plaque shall be black, and the background portion shall be orange.

3.2.27 Item 24 – 48”x48” EMERGENCY RESPONSE TRAILER DETOUR SIGN WITH HOOK & LOOP FOR OVERLAY PLAQUES AND ARROW OVERLAY PLAQUE

Signs supplied as part of Bid Item 24 shall be per the attached drawing “**BID ITEM 24 MODIFIED STANDARD DETAIL**” (Exhibit Z). The text and border portions of the sign shall be black, and the background portion shall be orange. “DETOUR” text size shall be 7” Series D. Border shall be 1.25”. Margin shall be 0.75”. Corner Radius shall be 3”. 2 ea. 41-1/2” long x 1” (min) wide pieces of orange H&L shall be glued or sewn onto the sign face, as shown on the attached modified standard detail, to facilitate the attachment of the interchangeable overlay plaques to be supplied as part of Bid Items 25 and 26. 4 ea. 6” long x ½” wide pieces of H&L shall be glued or sewn onto the sign face, as shown on the attached modified standard detail, to facilitate the attachment of the arrow overlay plaque as described below. Rib sizes, rib locations, rib lengths, corner pocket locations, and rotation point location shall be in substantial conformance as shown in the attached drawing (Exhibit BB) “**48x48 SQUARE – CORNER POCKET AND RIB CONFIGURATION**”.

REQUEST FOR QUOTATION
Reflective Roll-Up Signs

With each of the signs supplied as part of this bid item, 1 ea. separate arrow head plaque, as detailed on the above referenced modified standard detail (Exhibit AA), intended to be attached to the face of the sign shall be supplied. 8 ea. 6" long x ½" wide pieces of H&L shall be glued or sewn onto the back face of each plaque as shown on the modified standard detail. The arrow head and shaft portions of the plaque shall be black, and the background portion shall be orange.

**3.2.28 Item 25 – 9"x28" EMERGENCY RESPONSE TRAILER
ROUTE OVERLAY PLAQUE FOR ITEM 24**

Items supplied as part of Bid Item 25 shall be individual route plaques intended to be attached to the face of signs supplied under Bid Item 24. The text portions of the plaques shall be black, and the background portions shall be orange. The overall size of each individual plaque shall be 9" tall x 28" wide. Text shall be 8" Series D, or, if necessary, 8" Series C as required for 3 digit routes. Text shall be centered vertically and horizontally in each plaque. Format of text shall be "Route Classification"- "Hyphen"- "Route Number" (i.e. "US-119", "WV-2", "I-79", etc.). 2 ea. 28" long x 1" (min) wide pieces of H&L shall be glued or sewn onto the back face of each plaque, with 1 ea. of the pieces along the top and bottom edges of the plaque, and with the outside edge of each piece along the outside edge of the plaque. Orders will specify the quantity of each individual route plaque to be supplied.

**3.2.29 Item 26 – 9"x7" EMERGENCY RESPONSE TRAILER
CARDINAL DIRECTION OVERLAY PLAQUE FOR ITEM
24**

Items supplied as part of Bid Item 26 shall be individual cardinal direction plaques intended to be attached to the face of signs supplied under Bid Item 24. The text portions of the plaques shall be black, and the background portions shall be orange. The overall size of each individual plaque shall be 9" tall x 7" wide. Text shall be 8" Series D. Text shall be centered vertically and horizontally in each plaque. 2 ea. 7" long x 1" (min) wide pieces of H&L shall be glued or sewn onto the back face of each plaque, with 1 ea. of the pieces along the top and bottom edges of the plaque, and with the outside edge of each piece along the outside edge of the plaque. Orders will specify the quantity of each individual plaque ("N", "S", "E", and "W") to be supplied.

**3.2.30 Item 27 – 48"x48" DIAMOND, FLUORESCENT ORANGE,
STANDARD MESSAGE ROLL-UP SIGN**

Items supplied as part of Bid Item 27 shall be standard message (as shown in the WVDOH Sign Fabrication Details) orange and black 48"x48" diamond shaped construction zone warning signs. The text portions of the signs shall be black, and the background portions shall be orange. Rib sizes, rib locations, rib lengths, corner pocket locations, and rotation point location shall be in substantial conformance as shown in the attached drawing (Exhibit F) "48" DIAMOND – CORNER POCKET AND RIB CONFIGURATION". Orders will specify the quantity of each fabrication number to be supplied.

REQUEST FOR QUOTATION
Reflective Roll-Up Signs

3.2.31 Item 28 – 48”x48” DIAMOND, FLUORESCENT ORANGE, STANDARD MESSAGE ROLL-UP SIGN, WITH PERMANENT ADDITION OF TWO (2) 18”X18” VINYL FOLDING FLAGS

Items supplied as part of Bid Item 28 shall be standard message (as shown in the WVDOH Sign Fabrication Details) orange and black 48”x48” diamond shaped construction zone warning signs, with the addition of 2 ea. 18” x 18” non-reflective fluorescent orange vinyl flags, as specified above. The text portions of the signs shall be black, and the background portions shall be orange. Rib sizes, rib locations, rib lengths, corner pocket locations, and rotation point location shall be in substantial conformance as shown in the attached drawing (Exhibit F) “48” DIAMOND – CORNER POCKET AND RIB CONFIGURATION”. Orders will specify the quantity of each fabrication number to be supplied.

3.2.32 Item 29 – 36”x36” DIAMOND, FLUORESCENT ORANGE, STANDARD MESSAGE ROLL-UP SIGN

Items supplied as part of Bid Item 29 shall be standard message (as shown in the WVDOH Sign Fabrication Details) orange and black 36”x36” diamond shaped construction zone warning signs. The text portions of the signs shall be black, and the background portions shall be orange. Rib sizes, rib locations, rib lengths, corner pocket locations, and rotation point location shall be in substantial conformance as shown in the attached drawing (Exhibit E) “36” DIAMOND – CORNER POCKET AND RIB CONFIGURATION”. Orders will specify the quantity of each fabrication number to be supplied.

3.2.33 Item 30 – 36”x36” DIAMOND, FLUORESCENT ORANGE, STANDARD MESSAGE ROLL-UP SIGN, WITH PERMANENT ADDITION OF TWO (2) 18”X18” VINYL FOLDING FLAGS

Items supplied as part of Bid Item 30 shall be standard message (as shown in the WVDOH Sign Fabrication Details) orange and black 36”x36” diamond shaped construction zone warning signs, with the addition of 2 ea. 18” x 18” non-reflective fluorescent orange vinyl flags, as specified above. The text portions of the signs shall be black, and the background portions shall be orange. Rib sizes, rib locations, rib lengths, corner pocket locations, and rotation point location shall be in substantial conformance as shown in the attached drawing (Exhibit E) “36” DIAMOND – CORNER POCKET AND RIB CONFIGURATION”. Orders will specify the quantity of each fabrication number to be supplied.

3.2.34 Item 31 – 48”x48” DIAMOND, FLUORESCENT ORANGE, STANDARD MESSAGE ROLL-UP SIGN WITH HOOK & LOOP STRIPS FOR OVERLAY ATTACHMENTS

Items supplied as part of Bid Item 31 shall be standard message (as shown in the WVDOH Sign Fabrication Details) orange and black 48”x48” diamond shaped construction zone warning signs with the addition of 2 ea. 28” long x 1/2” wide and/or 2 ea. 23” long x 1/2” wide orange H&L strips to be glued or sewn onto the sign face. The H&L strips shall be installed horizontally and parallel to one another, with the measured

REQUEST FOR QUOTATION
Reflective Roll-Up Signs

distance between the outside edges of the strips to be 8". The mid-point along (14" and/or 11-1/2") and between (4") the strips shall be centered vertically and horizontally about the portion of text in the sign specified. The text portions of the signs shall be black, and the background portions shall be orange. Rib sizes, rib locations, rib lengths, corner pocket locations, and rotation point location shall be in substantial conformance as shown in the attached drawing (Exhibit F) "48" DIAMOND – CORNER POCKET AND RIB CONFIGURATION".

For further guidance, included as part of this Contract is a listing of individual signs with which supplemental overlay plaques are frequently used (Exhibit CC). For each sign with multiple possible messages through the use of overlay plaques, this listing specifies a "base" sign message. Each sign ordered with H&L in order to incorporate overlay plaques shall be manufactured with the "base" sign message as the permanent message on the sign. All 48" signs ordered which may potentially be altered with overlay plaques shall be ordered with H&L strips under this Item number or Item number 32. Orders will specify the quantity of each fabrication number to be supplied.

3.2.35 Item 32 – 48"x48" DIAMOND, FLUORESCENT ORANGE, STANDARD MESSAGE ROLL-UP SIGN WITH PERMANENT ADDITION OF TWO (2) 18"x18" VINYL FOLDING FLAGS, AND HOOK & LOOP STRIPS FOR OVERLAY ATTACHMENTS

Items supplied as part of Bid Item 32 shall be standard message (as shown in the WVDOT Sign Fabrication Details) orange and black 48"x48" diamond shaped construction zone warning signs, with the addition of 2 ea. 28" long x 1/2" wide and/or 2 ea. 23" long x 1/2" wide orange H&L strips to be glued or sewn onto the sign face, and 2 ea. 18" x 18" non-reflective fluorescent orange vinyl flags, as specified above. The H&L strips shall be installed horizontally and parallel to one another, with the measured distance between the outside edges of the strips to be 8". The mid-point along (14" and/or 11-1/2") and between (4") the strips shall be centered vertically and horizontally about the portion of text in the sign specified. The text portions of the signs shall be black, and the background portions shall be orange. Rib sizes, rib locations, rib lengths, corner pocket locations, and rotation point location shall be in substantial conformance as shown in the attached drawing (Exhibit F) "48" DIAMOND – CORNER POCKET AND RIB CONFIGURATION".

For further guidance, included as part of this Contract is a listing of individual signs with which supplemental overlay plaques are frequently used (Exhibit CC). For each sign with multiple possible messages through the use of overlay plaques, this listing specifies a "base" sign message. Each sign ordered with H&L in order to incorporate overlay plaques shall be manufactured with the "base" sign message as the permanent message on the sign. All 48" signs ordered which may potentially be altered with overlay plaques shall be ordered with H&L strips under this Item number or Item number 31. Orders will specify the quantity of each fabrication number to be supplied.

3.2.36 Item 33 – 36"x36" DIAMOND, FLUORESCENT ORANGE, STANDARD MESSAGE ROLL-UP SIGN WITH HOOK & LOOP STRIPS FOR OVERLAY ATTACHEMENTS

REQUEST FOR QUOTATION Reflective Roll-Up Signs

Items supplied as part of Bid Item 35 shall be standard message (as shown in the WVDOH Sign Fabrication Details) orange and black 36"x36" diamond shaped construction zone warning signs with the addition of 2 to 4 ea. 21" long x 1/2" wide orange H&L strips to be glued or sewn onto the sign face. The H&L strips shall be installed horizontally and parallel to one another, with the measured distance between the outside edges of the strips to be 6". The mid-point along (10-1/2") and between (3") the strips shall be centered vertically and horizontally about the portion of text in the sign specified. The text portions of the signs shall be black, and the background portions shall be orange. Rib sizes, rib locations, rib lengths, corner pocket locations, and rotation point location shall be in substantial conformance as shown in the attached drawing (Exhibit E) "36" DIAMOND – CORNER POCKET AND RIB CONFIGURATION".

For further guidance, included as part of this Contract is a listing of individual signs with which supplemental overlay plaques are frequently used (Exhibit CC). For each sign with multiple possible messages through the use of overlay plaques, this listing specifies a "base" sign message. Each sign ordered with H&L in order to incorporate overlay plaques shall be manufactured with the "base" sign message as the permanent message on the sign. All 36" signs ordered which may potentially be altered with overlay plaques shall be ordered with H&L strips under this Item number or Item number 34. Orders will specify the quantity of each fabrication number to be supplied.

3.2.37 Item 34 – 36"x36" DIAMOND, FLUORESCENT ORANGE, STANDARD MESSAGE ROLL-UP SIGN WITH PERMANENT ADDITION OF TWO (2) 18"x18" VINYL FOLDING FLAGS, AND HOOK & LOOP STRIPS FOR OVERLAY ATTACHMENTS

Items supplied as part of Bid Item 34 shall be standard message (as shown in the WVDOH Sign Fabrication Details) orange and black 36"x36" diamond shaped construction zone warning signs with the addition of 2 to 4 ea. 21" long x 1/2" wide orange H&L strips to be glued or sewn onto the sign face, and 2 ea. 18" x 18" non-reflective fluorescent orange vinyl flags, as specified above. The H&L strips shall be installed horizontally and parallel to one another, with the measured distance between the outside edges of the strips to be 6". The mid-point along (10-1/2") and between (3") the strips shall be centered vertically and horizontally about the portion of text in the sign specified. The text portions of the signs shall be black, and the background portions shall be orange. Rib sizes, rib locations, rib lengths, corner pocket locations, and rotation point location shall be in substantial conformance as shown in the attached drawing (Exhibit E) "36" DIAMOND – CORNER POCKET AND RIB CONFIGURATION".

For further guidance, included as part of this Contract is a listing of individual signs with which supplemental overlay plaques are frequently used (Exhibit CC). For each sign with multiple possible messages through the use of overlay plaques, this listing specifies a "base" sign message. Each sign ordered with H&L in order to incorporate overlay plaques shall be manufactured with the "base" sign message as the permanent message on the sign. All 36" signs ordered which may potentially be altered with overlay plaques shall be ordered with H&L strips under this Item number or Item number 33. Orders will specify the quantity of each fabrication number to be supplied.

REQUEST FOR QUOTATION
Reflective Roll-Up Signs

3.2.38 Item 35 – 8”x23” (“LEFT” AND “CENTER” TEXT ONLY) OR 8”x28” FLUORESCENT ORANGE OVERLAYS WITH HOOK & LOOP STRIPS FOR USE WITH ITEM 31 AND 32. EXAMPLES; LEFT, 500 FT., 1000 FT., 1500 FT., ½ MILE, AND 1 MILE

Items supplied as part of Bid Item 35 shall be individual message plaques intended to be attached to the face of signs supplied under Bid Items 31 and 32. The text portions of the plaques shall be black, and the background portions shall be orange. The overall size of each individual plaque, with the exception of “LEFT” and “CENTER” plaques, shall be 8” tall x 28” wide. “LEFT” and “CENTER” plaques shall be 8” tall x 23” wide. Text shall be 7” Series C. Text shall be centered vertically and horizontally in each plaque. 2 ea. 28” (23” in the case of “LEFT” or “CENTER” plaque) long x ½” wide pieces of H&L shall be glued or sewn onto the back face of each plaque, with 1 ea. of the pieces along the top and bottom edges of the plaque, and with the outside edge of each piece along the outside edge of the plaque. Orders will specify the quantity of each individual plaque to be supplied.

Note, “AHEAD” plaques shall not be manufactured or supplied under this Item number.

3.2.39 Item 36 – 6”x21” FLUORESCENT ORANGE OVERLAYS WITH HOOK & LOOP STRIPS FOR USE WITH ITEM NUMBERS 35 AND 36. EXAMPLES: LEFT, 500 FT., 1000 FT., 1500 FT., ½ MILE, 1 MILE, AND AHEAD

Items supplied as part of Bid Item 36 shall be individual message plaques intended to be attached to the face of signs supplied under Bid Items 33 and 34. The text portions of the plaques shall be black, and the background portions shall be orange. The overall size of each individual plaque shall be 6” tall x 21” wide. Text shall be 5” Series C. Text shall be centered vertically and horizontally in each plaque. 2 ea. 21” long x ½” wide pieces of H&L shall be glued or sewn onto the back face of each plaque, with 1 ea. of the pieces along the top and bottom edges of the plaque, and with the outside edge of each piece along the outside edge of the plaque. Orders will specify the quantity of each individual plaque to be supplied.

3.2.40 Item 37 – 18”x36” G20-2 “END ROAD WORK” SIGN

Signs supplied as part of Bid Item 37 shall be per the WVDOH Sign Fabrication Details, fabrication number G20-2, 18”x36”. Rib sizes, rib locations, rib lengths, corner pocket locations, and rotation point location shall be in substantial conformance as shown in the attached drawing (Exhibit DD) “18x36 HORIZONTAL RECTANGLE – CORNER POCKET AND RIB CONFIGURATION”.

3.2.41 Item 38 – 36” W3-1MF SYMBOLIC “STOP AHEAD” SIGN, FLUORESCENT PINK

Signs supplied as part of Bid Item 38 shall be per the WVDOH Sign Fabrication Details, fabrication number W3-1M, 36”, with the exception of the background color. An fl-pink background shall be used. The symbol may be glued or sewn onto the sign face separately. Rib sizes, rib locations, rib lengths, corner pocket locations, and rotation point

REQUEST FOR QUOTATION
Reflective Roll-Up Signs

location shall be in substantial conformance as shown in the attached drawing (Exhibit E) **"36" DIAMOND – CORNER POCKET AND RIB CONFIGURATION"**.

3.2.42 Item 39 – 48" W3-1MF SYMBOLIC "STOP AHEAD" SIGN, FLUORESCENT PINK

Signs supplied as part of Bid Item 39 shall be per the WVDOH Sign Fabrication Details, fabrication number W3-1M, 48", with the exception of the background color. An fl-pink background shall be used. The symbol may be glued or sewn onto the sign face separately. Rib sizes, rib locations, rib lengths, corner pocket locations, and rotation point location shall be in substantial conformance as shown in the attached drawing (Exhibit F) **"48" DIAMOND – CORNER POCKET AND RIB CONFIGURATION"**.

3.2.43 Item 40 – 36" W3-2MF SYMBOLIC "YIELD AHEAD" SIGN, FLUORESCENT PINK

Signs supplied as part of Bid Item 40 shall be per the WVDOH Sign Fabrication Details, fabrication number W3-2M, 36", with the exception of the background color. An fl-pink background shall be used. The symbol may be glued or sewn onto the sign face separately. Rib sizes, rib locations, rib lengths, corner pocket locations, and rotation point location shall be in substantial conformance as shown in the attached drawing (Exhibit E) **"36" DIAMOND – CORNER POCKET AND RIB CONFIGURATION"**.

3.2.44 Item 41 – 48" W3-2MF SYMBOLIC "YIELD AHEAD" SIGN, FLUORESCENT PINK

Signs supplied as part of Bid Item 41 shall be per the WVDOH Sign Fabrication Details, fabrication number W3-2M, 48", with the exception of the background color. An fl-pink background shall be used. The symbol may be glued or sewn onto the sign face separately. Rib sizes, rib locations, rib lengths, corner pocket locations, and rotation point location shall be in substantial conformance as shown in the attached drawing (Exhibit F) **"48" DIAMOND – CORNER POCKET AND RIB CONFIGURATION"**.

3.2.45 Item 42 – 48"x36" W22-10F "EXIT _____" WITH HOOK & LOOP FOR OVERLAYS, FLUORESCENT PINK

Signs supplied as part of Bid Item 42 shall be per the attached drawing **"BID ITEM 20 MODIFIED STANDARD DETAIL"** (Exhibit T). The text and border portions of the sign shall be black, and the background portion shall be fl-pink. 2 ea. 40" long x 1" (min) wide pieces of H&L shall be glued or sewn onto the sign face, as shown on the attached modified standard detail, to facilitate the attachment of the interchangeable message plaques to be supplied as part of Bid Item 43. Rib sizes, rib locations, rib lengths, corner pocket locations, and rotation point location shall be in substantial conformance as shown in the attached drawing (Exhibit U) **"48x36 HORIZONTAL RECTANGLE – CORNER POCKET AND RIB CONFIGURATION"**.

3.2.46 Item 43 – 10"x40" "OPEN" AND "CLOSED" OVERLAY PLAQUES FOR ITEM #44, FLUORESCENT PINK

Items supplied as part of Bid Item 43 shall be individual message plaques intended to be attached to the face of signs supplied under Bid Item 42. The text portions of the plaques

REQUEST FOR QUOTATION
Reflective Roll-Up Signs

shall be black, and the background portions shall be fl-pink. The overall size of each individual plaque shall be 10" tall x 40" wide. Text shall be 8" Series D, and shall be centered vertically and horizontally in each plaque. 2 ea. 40" long x 1" (min) wide pieces of H&L shall be glued or sewn onto the back face of each plaque, with 1 ea. of the pieces along the top and bottom edges of the plaque, and with the outside edge of each piece along the outside edge of the plaque. Orders will specify the quantity of each individual message ("OPEN" and "CLOSED") to be supplied.

3.2.47 Item 44 – 30"x24" M4-9F STANDARD DETOUR SIGN WITH HOOK & LOOP AND ARROW OVERLAY PLAQUE, FLUORESCENT PINK

Signs supplied as part of Bid Item 44 shall be per the attached drawing (Exhibit W) "BID ITEM 23 MODIFIED STANDARD DETAIL". The text and border portions of the sign shall be black, and the background portion shall be fl-pink. 4 ea. 5" long x ½" wide pieces of H&L shall be glued or sewn onto the sign face, as shown on the attached modified standard detail, to facilitate the attachment of the arrow overlay plaque as described below. Rib sizes, rib locations, rib lengths, corner pocket locations, and rotation point location shall be in substantial conformance as shown in the attached drawing (Exhibit Y) "30X24 HORIZONTAL RECTANGLE – CORNER POCKET AND RIB CONFIGURATION".

With each of the signs supplied as part of this bid item, 1 ea. separate arrow head plaque, intended to be attached to the face of the sign as detailed on the above referenced modified standard detail (Exhibit X), shall be supplied. 8 ea. 5" long x ½" wide pieces of H&L shall be glued or sewn onto the back face of each plaque as shown on the modified standard detail. The arrow head and shaft portions of the plaque shall be black, and the background portion shall be fl-pink.

3.2.48 Item 45 – 48"x48" EMERGENCY RESPONSE TRAILER DETOUR SIGN WITH HOOK & LOOP FOR OVERLAY PLAQUES AND ARROW OVERLAY PLAQUE, FLUORESCENT PINK

Signs supplied as part of Bid Item 45 shall be per the attached drawing "BID ITEM 24 MODIFIED STANDARD DETAIL" (Exhibit Z). The text and border portions of the sign shall be black, and the background portion shall be fl-pink. "DETOUR" text size shall be 7" Series D. Border shall be 1.25". Margin shall be 0.75". Corner Radius shall be 3". 2 ea. 41-1/2" long x 1" (min) wide pieces of pink H&L shall be glued or sewn onto the sign face, as shown on the attached modified standard detail, to facilitate the attachment of the interchangeable overlay plaques to be supplied as part of Bid Items 48 and 49. 4 ea. 6" long x ½" wide pieces of H&L shall be glued or sewn onto the sign face, as shown on the attached modified standard detail, to facilitate the attachment of the arrow overlay plaque as described below. Rib sizes, rib locations, rib lengths, corner pocket locations, and rotation point location shall be in substantial conformance as shown in the attached drawing (Exhibit BB) "48x48 SQUARE – CORNER POCKET AND RIB CONFIGURATION".

With each of the signs supplied as part of this bid item, 1 ea. separate arrow head plaque, as detailed on the above referenced modified standard detail (Exhibit AA), intended to be

REQUEST FOR QUOTATION
Reflective Roll-Up Signs

attached to the face of the sign shall be supplied. 8 ea. 6" long x ½" wide pieces of H&L shall be glued or sewn onto the back face of each plaque as shown on the modified standard detail. The arrow head and shaft portions of the plaque shall be black, and the background portion shall be fl-pink.

3.2.49 Item 46 – 9"x28" EMERGENCY RESPONSE TRAILER ROUTE OVERLAY PLAQUE FOR ITEM 45, FLUORESCENT PINK

Items supplied as part of Bid Item 46 shall be individual route plaques intended to be attached to the face of signs supplied under Bid Item 45. The text portions of the plaques shall be black, and the background portions shall be fl-pink. The overall size of each individual plaque shall be 9" tall x 28" wide. Text shall be 8" Series D, or, if necessary, 8" Series C as required for 3 digit routes. Text shall be centered vertically and horizontally in each plaque. Format of text shall be "Route Classification"- "Hyphen"- "Route Number" (i.e. "US-119", "WV-2", "I-79", etc.). 2 ea. 28" long x 1" (min) wide pieces of H&L shall be glued or sewn onto the back face of each plaque, with 1 ea. of the pieces along the top and bottom edges of the plaque, and with the outside edge of each piece along the outside edge of the plaque. Orders will specify the quantity of each individual route plaque to be supplied.

3.2.50 Item 47 – 9"x7" EMERGENCY RESPONSE TRAILER CARDINAL DIRECTION OVERLAY PLAQUE FOR ITEM 45, FLUORESCENT PINK

Items supplied as part of Bid Item 47 shall be individual cardinal direction plaques intended to be attached to the face of signs supplied under Bid Item 45. The text portions of the plaques shall be black, and the background portions shall be fl-pink. The overall size of each individual plaque shall be 9" tall x 7" wide. Text shall be 8" Series D. Text shall be centered vertically and horizontally in each plaque. 2 ea. 7" long x 1" (min) wide pieces of H&L shall be glued or sewn onto the back face of each plaque, with 1 ea. of the pieces along the top and bottom edges of the plaque, and with the outside edge of each piece along the outside edge of the plaque. Orders will specify the quantity of each individual plaque ("N", "S", "E", and "W") to be supplied.

3.2.51 Item 48 – 48"x48" DIAMOND, FLUORESCENT PINK, STANDARD MESSAGE ROLL-UP SIGN

Items supplied as part of Bid Item 48 shall be standard message (as shown in the WVDOH Sign Fabrication Details) fl-pink and black 48"x48" diamond shaped warning signs. The text portions of the signs shall be black, and the background portions shall be fl-pink. Rib sizes, rib locations, rib lengths, corner pocket locations, and rotation point location shall be in substantial conformance as shown in the attached drawing (Exhibit F) "48" DIAMOND – CORNER POCKET AND RIB CONFIGURATION". Orders will specify the quantity of each fabrication number to be supplied.

The Agency reserves the right to order additional signs with messages not currently specified in the MUTCD (non-standard messages). Such signs shall be indicated on the order. The size, font type, spacing, and layout of the text on such signs shall be in conformance with the recommendations of the MUTCD. When such non-standard

REQUEST FOR QUOTATION
Reflective Roll-Up Signs

message signs are ordered, the Vendor shall provide electronic shop drawings of these signs by email to the Agency for approval prior to proceeding with fabrication.

**3.2.52 Item 49 – 36”x36” DIAMOND, FLUORESCENT PINK ,
STANDARD MESSAGE ROLL-UP SIGN**

Items supplied as part of Bid Item 49 shall be standard message (as shown in the WVDOH Sign Fabrication Details) fl-pink and black 36”x36” diamond shaped warning signs. The text portions of the signs shall be black, and the background portions shall be fl-pink. Rib sizes, rib locations, rib lengths, corner pocket locations, and rotation point location shall be in substantial conformance as shown in the attached drawing (Exhibit E) “36” DIAMOND – CORNER POCKET AND RIB CONFIGURATION”. Orders will specify the quantity of each fabrication number to be supplied.

The Agency reserves the right to order additional signs with messages not currently specified in the MUTCD (non-standard messages). Such signs shall be indicated on the order. The size, font type, spacing, and layout of the text on such signs shall be in conformance with the recommendations of the MUTCD. When such non-standard message signs are ordered, the Vendor shall provide electronic shop drawings of these signs by email to the Agency for approval prior to proceeding with fabrication.

**3.2.53 Item 50 – 48”x48” DIAMOND, FLUORESCENT PINK,
STANDARD MESSAGE ROLL-UP SIGN WITH HOOK &
LOOP STRIPS FOR OVERLAY ATTACHMENTS**

Items supplied as part of Bid Item 50 shall be standard message (as shown in the WVDOH Sign Fabrication Details) fl-pink and black 48”x48” diamond shaped warning signs with the addition of 2 ea. 28” long x 1/2” wide and/or 2 ea. 23” long x 1/2” wide pink H&L strips to be glued or sewn onto the sign face. The H&L strips shall be installed horizontally and parallel to one another, with the measured distance between the outside edges of the strips to be 8”. The mid-point along (14” and/or 11-1/2”) and between (4”) the strips shall be centered vertically and horizontally about the portion of text in the sign specified. The text portions of the signs shall be black, and the background portions shall be fl-pink. Rib sizes, rib locations, rib lengths, corner pocket locations, and rotation point location shall be in substantial conformance as shown in the attached drawing (Exhibit F) “48” DIAMOND – CORNER POCKET AND RIB CONFIGURATION”.

For further guidance, included as part of this Contract is a listing of individual signs with which supplemental overlay plaques are frequently used (Exhibit CC). For each sign with multiple possible messages through the use of overlay plaques, this listing specifies a “base” sign message. Each sign ordered with H&L in order to incorporate overlay plaques shall be manufactured with the “base” sign message as the permanent message on the sign. All 48” signs ordered which may potentially be altered with overlay plaques shall be ordered with H&L strips under this Item number. Orders will specify the quantity of each fabrication number to be supplied.

The Agency reserves the right to order additional signs with messages not currently specified in the MUTCD (non-standard messages). Such signs shall be indicated on the order. The size, font type, spacing, and layout of the text on such signs shall be in conformance with the recommendations of the MUTCD. When such non-standard

REQUEST FOR QUOTATION
Reflective Roll-Up Signs

message signs are ordered, the Vendor shall provide electronic shop drawings of these signs by email to the Agency for approval prior to proceeding with fabrication.

3.2.54 Item 51 – 36”x36” DIAMOND, FLUORESCENT PINK, STANDARD MESSAGE ROLL-UP SIGN WITH HOOK & LOOP STRIPS FOR OVERLAY ATTACHEMENTS

Items supplied as part of Bid Item 51 shall be standard message (as shown in the WVDOH Sign Fabrication Details) fl-pink and black 36”x36” diamond shaped construction zone warning signs with the addition of 2 to 4 ea. 21” long x 1/2” wide pink H&L strips to be glued or sewn onto the sign face. The H&L strips shall be installed horizontally and parallel to one another, with the measured distance between the outside edges of the strips to be 6”. The mid-point along (10-1/2”) and between (3”) the strips shall be centered vertically and horizontally about the portion of text in the sign specified. The text portions of the signs shall be black, and the background portions shall be fl-pink. Rib sizes, rib locations, rib lengths, corner pocket locations, and rotation point location shall be in substantial conformance as shown in the attached drawing (Exhibit E) “36” DIAMOND – CORNER POCKET AND RIB CONFIGURATION”.

For further guidance, included as part of this Contract is a listing of individual signs with which supplemental overlay plaques are frequently used (Exhibit CC). For each sign with multiple possible messages through the use of overlay plaques, this listing specifies a “base” sign message. Each sign ordered with H&L in order to incorporate overlay plaques shall be manufactured with the “base” sign message as the permanent message on the sign. All 36” signs ordered which may potentially be altered with overlay plaques shall be ordered with H&L strips under this Item number.

Orders will specify the quantity of each fabrication number to be supplied.

The Agency reserves the right to order additional signs with messages not currently specified in the MUTCD (non-standard messages). Such signs shall be indicated on the order. The size, font type, spacing, and layout of the text on such signs shall be in conformance with the recommendations of the MUTCD. When such non-standard message signs are ordered, the Vendor shall provide electronic shop drawings of these signs by email to the Agency for approval prior to proceeding with fabrication.

3.2.55 Item 52 – 8”x23” (“LEFT” AND “CENTER” TEXT ONLY) OR 8”x28” FLUORESCENT PINK OVERLAYS WITH HOOK & LOOP STRIPS FOR USE WITH ITEM 50. EXAMPLES; LEFT, 500 FT., 1000 FT., 1500 FT., ½ MILE, AND 1 MILE

Items supplied as part of Bid Item 52 shall be individual message plaques intended to be attached to the face of signs supplied under Bid Item 50. The text portions of the plaques shall be black, and the background portions shall be fl-pink. The overall size of each individual plaque, with the exception of “LEFT” and “CENTER” plaques, shall be 8” tall x 28” wide. “LEFT” and “CENTER” plaques shall be 8” tall x 23” wide. Text shall be 7” Series C. Text shall be centered vertically and horizontally in each plaque. 2 ea. 28” (23” in the case of “LEFT” or “CENTER” plaque) long x 1/2” wide pieces of H&L shall be glued or sewn onto the back face of each plaque, with 1 ea. of the pieces along the top and bottom edges of the plaque, and with the outside edge of each piece along the outside

REQUEST FOR QUOTATION
Reflective Roll-Up Signs

edge of the plaque. Orders will specify the quantity of each individual plaque to be supplied.

Note, "AHEAD" plaques shall not be manufactured or supplied under this Item number.

3.2.56 Item 53 – 6"x21" FLUORESCENT PINK OVERLAYS WITH HOOK & LOOP STRIPS FOR USE WITH ITEM NUMBER 53. EXAMPLES: LEFT, 500 FT., 1000 FT., 1500 FT., ½ MILE, 1 MILE, AND AHEAD

Items supplied as part of Bid Item 53 shall be individual message plaques intended to be attached to the face of signs supplied under Bid Item 51. The text portions of the plaques shall be black, and the background portions shall be fl-orange. The overall size of each individual plaque shall be 6" tall x 21" wide. Text shall be 5" Series C. Text shall be centered vertically and horizontally in each plaque. 2 ea. 21" long x ½" wide pieces of H&L shall be glued or sewn onto the back face of each plaque, with 1 ea. of the pieces along the top and bottom edges of the plaque, and with the outside edge of each piece along the outside edge of the plaque. Orders will specify the quantity of each individual plaque to be supplied.

3.3 Sheeting Manufacturer Certification

Bids submitted for this RFQ should include a letter of assurance which addresses reflective sheeting manufacturing and handling procedures. No Vendor shall be awarded any portion of this Contract which includes reflective signs without receipt of this letter by the Division, if required. This letter shall be addressed from the sheeting manufacturer to the manufacturer of the product to be supplied as part of this Contract. If the Vendor intends to utilize different manufacturers for different applicable products and/or different sheeting manufacturers, multiple letters may be required. The language of the letter shall provide sufficient indication, in the Division's judgment, that the reflective sheeting manufacturer has reviewed the recommended handling and manufacturing procedures for the reflective sheeting material with the product manufacturer. The sole purpose of this requirement is for the Division to verify that a) the sheeting manufacturer is aware of the product manufacturer's recommended handling and manufacturing procedures, and b) that the sheeting manufacturer has made the product manufacturer aware of the recommended procedures for handling and manufacturing with the reflective material. If, during the life of the Contract, the product manufacturer intends to begin utilizing a different approved reflective sheeting than originally indicated in the Vendor's RFQ response, the Vendor shall make this request in writing and shall provide a new letter of assurance if determined by the Division to be necessary.

REQUEST FOR QUOTATION
Reflective Roll-Up Signs

4 CONTRACT AWARD:

4.1 Contract Award: The Contract is intended to provide Agencies with a purchase price on all Contract Items. The Contract shall be awarded to the Vendor that provides the Contract Items meeting the required specifications for the lowest overall total cost as shown on the Pricing Pages.

The Product Compliance Checklist Form that is attached as Exhibit B should be included with the bid package completed in its' entirety by the vendor. This Contract shall not be awarded without receipt of the completed Checklist Forms.

4.2 Low Bidder Sample Sign Submittal: As part of the review of bids for this Contract, the Division may, at its' discretion, require bidders being considered for award of the Contract to submit sample signs for review. If required, the bidder(s) will be required to submit one or more of the following signs:

- 1 ea. Item #1
- 1 ea. Item #9
- 2 ea. Item #10 (1 ea. "4", 1 ea. "5")
- 1 ea. Item #32, Fab # W20-5A, H&L positioned to allow "RIGHT" and "1500 FT" to be covered.
- 2 ea. Item #35 (1 ea. "LEFT", 1 ea. "500 FT")

The bidder(s) will be required to submit the signs requested within ten (10) working days of notification. Failure to supply the requested signs within this time frame may result in the disqualification of the vendor's bid. Samples are to be delivered to the following address:

WVDOH-Traffic Engineering Division
Traffic Services Complex
180 Dry Branch Dr.
Charleston, WV 25306
ATTN: Bruce Miller

4.3 Estimated Purchase Volume: The estimated purchase volume for each item represents the approximate volume of anticipated purchases only. No future use of the Contract or any individual item is guaranteed or implied.

4.4 Pricing Pages: Vendor should complete the Pricing Pages by filling in all required information. Vendor should complete the Pricing Pages

REQUEST FOR QUOTATION
Reflective Roll-Up Signs

in their entirety as failure to do so may result in Vendor's bids being disqualified.

The Pricing Pages contain a list of the Contract Items and estimated purchase volume. The estimated purchase volume for each item represents the approximate volume of anticipated purchases only. No future use of the Contract or any individual item is guaranteed or implied.

Vendor should electronically enter the information into the Pricing Pages through wvOASIS, if available, or as an electronic document. In most cases, the Vendor can request an electronic copy of the Pricing Pages for bid purposes by sending an email request to the following address: Crystal.G.Hustead@wv.gov

5 ORDERING AND PAYMENT:

5.1 Ordering: Vendor shall accept orders through wvOASIS, regular mail, facsimile, e-mail, or any other written form of communication. Vendor may, but is not required to, accept on-line orders through a secure internet ordering portal/website. If Vendor has the ability to accept on-line orders, it should include in its response a brief description of how Agencies may utilize the on-line ordering system. Vendor shall ensure that its on-line ordering system is properly secured prior to processing Agency orders on-line.

5.2 Payment: Vendor shall accept payment in accordance with the payment procedures of the State of West Virginia.

6 DELIVERY AND RETURN:

6.1 Delivery Time: Vendor shall deliver standard orders within 35 working days after orders are received. Vendor shall ship all orders in accordance with the above schedule and shall not hold orders until a minimum delivery quantity is met. Notification of shipment from Vendor shall be received a minimum of 48 hours before delivery of material at the location indicated on the release.

6.2 Delivery Locations: Typically, delivery locations will be to, but shall not be limited to, the locations of the ten WVDOH District Headquarters. The cities in which the District Headquarters are located are Charleston, Huntington, Parkersburg, Clarksburg, Burlington, Moundsville, Weston, Elkins, Lewisburg, and Princeton.

REQUEST FOR QUOTATION
Reflective Roll-Up Signs

6.3 Delivery Requirement: All components shall be shipped adequately and securely. Any material delivered not meeting the above requirement shall be subject to being returned to the Vendor at the Vendor's expense. In this case, the vendor shall be responsible for the shipment of the returned materials back to the purchasing organization, packaged as specified above. In addition, the provisions of 6.4 shall remain in effect. The order shall be considered "delivered in full" at the time of the delivery of the returned materials back to the purchasing organization.

6.4 Late Delivery: The Agency placing the order under this Contract must be notified in writing at the Blanket Release Order "Invoice To" address if orders will be delayed beyond the time frame specified in 6.1 for any reason. Any such delay in delivery will be grounds for:

- (a) Cancellation of the delayed order, and/or
- (b) Obtaining the items ordered from a third party, and/or
- (c) Subjecting the Vendor to a daily (per Calendar Day) penalty at the purchasing organizations discretion for each Calendar Day beyond thirty-two (32) working days ARO in the amount of \$40 until the order is received in full. This penalty shall be assessed by subtracting the penalty from the original total value of the Release Order.

Any Agency seeking to obtain items from a third party under this provision must first obtain approval of the Purchasing Division.

6.5 Delivery Payment/Risk of Loss: Standard order delivery shall be F.O.B. destination to the Agency's location. Vendor shall include the cost of standard order delivery charges in its bid pricing/discount and is not permitted to charge the Agency separately for such delivery. The Agency will pay delivery charges on all emergency orders provided that Vendor invoices those delivery costs as a separate charge with the original freight bill attached to the invoice.

6.6 Return of Unacceptable Items: If the Agency deems the Contract Items to be unacceptable, the Contract Items shall be returned to Vendor at Vendor's expense and with no restocking charge. Vendor shall either make arrangements for the return within five (5) days of being notified that items are unacceptable, or permit the Agency to arrange for the return and reimburse Agency for delivery expenses. If the original packaging cannot be utilized for the return, Vendor will supply the Agency with appropriate return packaging upon request. All returns of unacceptable items shall be F.O.B. the Agency's location. The returned product shall either be replaced, or the Agency shall receive a full credit or refund for the

REQUEST FOR QUOTATION
Reflective Roll-Up Signs

purchase price, at the Agency's discretion.

- 6.7 Return Due to Agency Error:** Items ordered in error by the Agency will be returned for credit within 30 days of receipt, F.O.B. Vendor's location. Vendor shall not charge a restocking fee if returned products are in a resalable condition. Items shall be deemed to be in a resalable condition if they are unused and in the original packaging. Any restocking fee for items not in a resalable condition shall be the lower of the Vendor's customary restocking fee or 5% of the total invoiced value of the returned items.

7 VENDOR DEFAULT:

7.1 The following shall be considered a vendor default under this Contract.

- 7.1.1** Failure to provide Contract Items in accordance with the requirements contained herein.
- 7.1.2** Failure to comply with other specifications and requirements contained herein.
- 7.1.3** Failure to comply with any laws, rules, and ordinances applicable to the Contract Services provided under this Contract.
- 7.1.4** Failure to remedy deficient performance upon request.

7.2 The following remedies shall be available to Agency upon default.

- 7.2.1** Immediate cancellation of the Contract.
- 7.2.2** Immediate cancellation of one or more release orders issued under this Contract.

REQUEST FOR QUOTATION
Reflective Roll-Up Signs

7.2.3 Any other remedies available in law or equity.

8 MISCELLANEOUS:

- 8.1 No Substitutions:** Vendor shall supply only Contract Items submitted in response to the RFQ unless a contract modification is approved in accordance with the provisions contained in this Contract.
- 8.2 Vendor Supply:** Vendor must carry sufficient inventory of the Contract Items being offered to fulfill its obligations under this Contract. By signing its bid, Vendor certifies that it can supply the Contract Items contained in its bid response.
- 8.3 Reports:** Vendor shall provide quarterly reports and annual summaries to the Agency showing the Agency's items purchased, quantities of items purchased, and total dollar value of the items purchased. Vendor shall also provide reports, upon request, showing the items purchased during the term of this Contract, the quantity purchased for each of those items, and the total value of purchases for each of those items. Failure to supply such reports may be grounds for cancellation of this Contract.
- 8.4 Contract Manager:** During its performance of this Contract, Vendor must designate and maintain a primary contract manager responsible for overseeing Vendor's responsibilities under this Contract. The Contract manager must be available during normal business hours to address any customer service or other issues related to this Contract. Vendor should list its Contract manager and his or her contact information below.

Contract Manager: Scott Wolf
Telephone Number: 630-251-7545
Fax Number: n/a
Email Address: scott@dicketool.com

GENERAL TERMS AND CONDITIONS:

1. CONTRACTUAL AGREEMENT: Issuance of an Award Document signed by the Purchasing Division Director, or his designee, and approved as to form by the Attorney General's office constitutes acceptance by the State of this Contract made by and between the State of West Virginia and the Vendor. Vendor's signature on its bid, or on the Contract if the Contract is not the result of a bid solicitation, signifies Vendor's agreement to be bound by and accept the terms and conditions contained in this Contract.

2. DEFINITIONS: As used in this Solicitation/Contract, the following terms shall have the meanings attributed to them below. Additional definitions may be found in the specifications included with this Solicitation/Contract.

2.1. "Agency" or "Agencies" means the agency, board, commission, or other entity of the State of West Virginia that is identified on the first page of the Solicitation or any other public entity seeking to procure goods or services under this Contract.

2.2. "Bid" or "Proposal" means the vendors submitted response to this solicitation.

2.3. "Contract" means the binding agreement that is entered into between the State and the Vendor to provide the goods or services requested in the Solicitation.

2.4. "Director" means the Director of the West Virginia Department of Administration, Purchasing Division.

2.5. "Purchasing Division" means the West Virginia Department of Administration, Purchasing Division.

2.6. "Award Document" means the document signed by the Agency and the Purchasing Division, and approved as to form by the Attorney General, that identifies the Vendor as the contract holder.

2.7. "Solicitation" means the official notice of an opportunity to supply the State with goods or services that is published by the Purchasing Division.

2.8. "State" means the State of West Virginia and/or any of its agencies, commissions, boards, etc. as context requires.

2.9. "Vendor" or "Vendors" means any entity submitting a bid in response to the Solicitation, the entity that has been selected as the lowest responsible bidder, or the entity that has been awarded the Contract as context requires.

3. CONTRACT TERM; RENEWAL; EXTENSION: The term of this Contract shall be determined in accordance with the category that has been identified as applicable to this Contract below:

Term Contract

Initial Contract Term: The Initial Contract Term will be for a period of One (1) . The Initial Contract Term becomes effective on the effective start date listed on the first page of this Contract, identified as the State of West Virginia contract cover page containing the signatures of the Purchasing Division, Attorney General, and Encumbrance clerk (or another page identified as _____), and the Initial Contract Term ends on the effective end date also shown on the first page of this Contract.

Renewal Term: This Contract may be renewed upon the mutual written consent of the Agency, and the Vendor, with approval of the Purchasing Division and the Attorney General's office (Attorney General approval is as to form only). Any request for renewal should be delivered to the Agency and then submitted to the Purchasing Division thirty (30) days prior to the expiration date of the initial contract term or appropriate renewal term. A Contract renewal shall be in accordance with the terms and conditions of the original contract. Unless otherwise specified below, renewal of this Contract is limited to three (3) successive one (1) year periods or multiple renewal periods of less than one year, provided that the multiple renewal periods do not exceed the total number of months available in all renewal years combined. Automatic renewal of this Contract is prohibited. Renewals must be approved by the Vendor, Agency, Purchasing Division and Attorney General's office (Attorney General approval is as to form only)

Alternate Renewal Term – This contract may be renewed for _____ successive _____ year periods or shorter periods provided that they do not exceed the total number of months contained in all available renewals. Automatic renewal of this Contract is prohibited. Renewals must be approved by the Vendor, Agency, Purchasing Division and Attorney General's office (Attorney General approval is as to form only)

Delivery Order Limitations: In the event that this contract permits delivery orders, a delivery order may only be issued during the time this Contract is in effect. Any delivery order issued within one year of the expiration of this Contract shall be effective for one year from the date the delivery order is issued. No delivery order may be extended beyond one year after this Contract has expired.

Fixed Period Contract: This Contract becomes effective upon Vendor's receipt of the notice to proceed and must be completed within _____ days.

Fixed Period Contract with Renewals: This Contract becomes effective upon Vendor's receipt of the notice to proceed and part of the Contract more fully described in the attached specifications must be completed within _____ days. Upon completion of the work covered by the preceding sentence, the vendor agrees that:

the contract will continue for _____ years;

the contract may be renewed for _____ successive _____ year periods or shorter periods provided that they do not exceed the total number of months contained in all available renewals. Automatic renewal of this Contract is prohibited. Renewals must be approved by the Vendor, Agency, Purchasing Division and Attorney General's Office (Attorney General approval is as to form only).

One-Time Purchase: The term of this Contract shall run from the issuance of the Award Document until all of the goods contracted for have been delivered, but in no event will this Contract extend for more than one fiscal year.

Construction/Project Oversight: This Contract becomes effective on the effective start date listed on the first page of this Contract, identified as the State of West Virginia contract cover page containing the signatures of the Purchasing Division, Attorney General, and Encumbrance clerk (or another page identified as _____), and continues until the project for which the vendor is providing oversight is complete.

Other: Contract Term specified in _____

4. AUTHORITY TO PROCEED: Vendor is authorized to begin performance of this contract on the date of encumbrance listed on the front page of the Award Document unless either the box for "Fixed Period Contract" or "Fixed Period Contract with Renewals" has been checked in Section 3 above. If either "Fixed Period Contract" or "Fixed Period Contract with Renewals" has been checked, Vendor must not begin work until it receives a separate notice to proceed from the State. The notice to proceed will then be incorporated into the Contract via change order to memorialize the official date that work commenced.

5. QUANTITIES: The quantities required under this Contract shall be determined in accordance with the category that has been identified as applicable to this Contract below.

Open End Contract: Quantities listed in this Solicitation/Award Document are approximations only, based on estimates supplied by the Agency. It is understood and agreed that the Contract shall cover the quantities actually ordered for delivery during the term of the Contract, whether more or less than the quantities shown.

Service: The scope of the service to be provided will be more clearly defined in the specifications included herewith.

Combined Service and Goods: The scope of the service and deliverable goods to be provided will be more clearly defined in the specifications included herewith.

One-Time Purchase: This Contract is for the purchase of a set quantity of goods that are identified in the specifications included herewith. Once those items have been delivered, no additional goods may be procured under this Contract without an appropriate change order approved by the Vendor, Agency, Purchasing Division, and Attorney General's office.

Construction: This Contract is for construction activity more fully defined in the specifications.

6. EMERGENCY PURCHASES: The Purchasing Division Director may authorize the Agency to purchase goods or services in the open market that Vendor would otherwise provide under this Contract if those goods or services are for immediate or expedited delivery in an emergency. Emergencies shall include, but are not limited to, delays in transportation or an unanticipated increase in the volume of work. An emergency purchase in the open market, approved by the Purchasing Division Director, shall not constitute a breach of this Contract and shall not entitle the Vendor to any form of compensation or damages. This provision does not excuse the State from fulfilling its obligations under a One-Time Purchase contract.

7. REQUIRED DOCUMENTS: All of the items checked in this section must be provided to the Purchasing Division by the Vendor as specified:

LICENSE(S) / CERTIFICATIONS / PERMITS: In addition to anything required under the Section of the General Terms and Conditions entitled Licensing, the apparent successful Vendor shall furnish proof of the following licenses, certifications, and/or permits upon request and in a form acceptable to the State. The request may be prior to or after contract award at the State's sole discretion.

The apparent successful Vendor shall also furnish proof of any additional licenses or certifications contained in the specifications regardless of whether or not that requirement is listed above.

8. INSURANCE: The apparent successful Vendor shall furnish proof of the insurance identified by a checkmark below prior to Contract award. The insurance coverages identified below must be maintained throughout the life of this contract. Thirty (30) days prior to the expiration of the insurance policies, Vendor shall provide the Agency with proof that the insurance mandated herein has been continued. Vendor must also provide Agency with immediate notice of any changes in its insurance policies, including but not limited to, policy cancelation, policy reduction, or change in insurers. The apparent successful Vendor shall also furnish proof of any additional insurance requirements contained in the specifications prior to Contract award regardless of whether that insurance requirement is listed in this section.

Vendor must maintain:

Commercial General Liability Insurance in at least an amount of: \$1,000,000 per occurrence.

Automobile Liability Insurance in at least an amount of: _____ per occurrence.

Professional/Malpractice/Errors and Omission Insurance in at least an amount of: _____ per occurrence. Notwithstanding the forgoing, Vendor's are not required to list the State as an additional insured for this type of policy.

Commercial Crime and Third Party Fidelity Insurance in an amount of: _____ per occurrence.

Cyber Liability Insurance in an amount of: _____ per occurrence.

Builders Risk Insurance in an amount equal to 100% of the amount of the Contract.

Pollution Insurance in an amount of: _____ per occurrence.

Aircraft Liability in an amount of: _____ per occurrence.

9. WORKERS' COMPENSATION INSURANCE: Vendor shall comply with laws relating to workers compensation, shall maintain workers' compensation insurance when required, and shall furnish proof of workers' compensation insurance upon request.

10. VENUE: All legal actions for damages brought by Vendor against the State shall be brought in the West Virginia Claims Commission. Other causes of action must be brought in the West Virginia court authorized by statute to exercise jurisdiction over it.

11. LIQUIDATED DAMAGES: This clause shall in no way be considered exclusive and shall not limit the State or Agency's right to pursue any other available remedy. Vendor shall pay liquidated damages in the amount specified below or as described in the specifications:

_____ for _____.

Liquidated Damages Contained in the Specifications.

Liquidated Damages Are Not Included in this Contract.

12. ACCEPTANCE: Vendor's signature on its bid, or on the certification and signature page, constitutes an offer to the State that cannot be unilaterally withdrawn, signifies that the product or service proposed by vendor meets the mandatory requirements contained in the Solicitation for that product or service, unless otherwise indicated, and signifies acceptance of the terms and conditions contained in the Solicitation unless otherwise indicated.

13. PRICING: The pricing set forth herein is firm for the life of the Contract, unless specified elsewhere within this Solicitation/Contract by the State. A Vendor's inclusion of price adjustment provisions in its bid, without an express authorization from the State in the Solicitation to do so, may result in bid disqualification. Notwithstanding the foregoing, Vendor must extend any publicly advertised sale price to the State and invoice at the lower of the contract price or the publicly advertised sale price.

14. PAYMENT IN ARREARS: Payments for goods/services will be made in arrears only upon receipt of a proper invoice, detailing the goods/services provided or receipt of the goods/services, whichever is later. Notwithstanding the foregoing, payments for software maintenance, licenses, or subscriptions may be paid annually in advance.

15. PAYMENT METHODS: Vendor must accept payment by electronic funds transfer and P-Card. (The State of West Virginia's Purchasing Card program, administered under contract by a banking institution, processes payment for goods and services through state designated credit cards.)

16. TAXES: The Vendor shall pay any applicable sales, use, personal property or any other taxes arising out of this Contract and the transactions contemplated thereby. The State of West Virginia is exempt from federal and state taxes and will not pay or reimburse such taxes.

17. ADDITIONAL FEES: Vendor is not permitted to charge additional fees or assess additional charges that were not either expressly provided for in the solicitation published by the State of West Virginia, included in the Contract, or included in the unit price or lump sum bid amount that Vendor is required by the solicitation to provide. Including such fees or charges as notes to the solicitation may result in rejection of vendor's bid. Requesting such fees or charges be paid after the contract has been awarded may result in cancellation of the contract.

18. FUNDING: This Contract shall continue for the term stated herein, contingent upon funds being appropriated by the Legislature or otherwise being made available. In the event funds are not appropriated or otherwise made available, this Contract becomes void and of no effect beginning on July 1 of the fiscal year for which funding has not been appropriated or otherwise made available. If that occurs, the State may notify the Vendor that an alternative source of funding has been obtained and thereby avoid the automatic termination. Non-appropriation or non-funding shall not be considered an event of default.

19. CANCELLATION: The Purchasing Division Director reserves the right to cancel this Contract immediately upon written notice to the vendor if the materials or workmanship supplied do not conform to the specifications contained in the Contract. The Purchasing Division Director may also cancel any purchase or Contract upon 30 days written notice to the Vendor in accordance with West Virginia Code of State Rules § 148-1-5.2.b.

20. TIME: Time is of the essence regarding all matters of time and performance in this Contract.

21. APPLICABLE LAW: This Contract is governed by and interpreted under West Virginia law without giving effect to its choice of law principles. Any information provided in specification manuals, or any other source, verbal or written, which contradicts or violates the West Virginia Constitution, West Virginia Code, or West Virginia Code of State Rules is void and of no effect.

22. COMPLIANCE WITH LAWS: Vendor shall comply with all applicable federal, state, and local laws, regulations and ordinances. By submitting a bid, Vendor acknowledges that it has reviewed, understands, and will comply with all applicable laws, regulations, and ordinances.

SUBCONTRACTOR COMPLIANCE: Vendor shall notify all subcontractors providing commodities or services related to this Contract that as subcontractors, they too are required to comply with all applicable laws, regulations, and ordinances. Notification under this provision must occur prior to the performance of any work under the contract by the subcontractor.

23. ARBITRATION: Any references made to arbitration contained in this Contract, Vendor's bid, or in any American Institute of Architects documents pertaining to this Contract are hereby deleted, void, and of no effect.

24. MODIFICATIONS: This writing is the parties' final expression of intent. Notwithstanding anything contained in this Contract to the contrary no modification of this Contract shall be binding without mutual written consent of the Agency, and the Vendor, with approval of the Purchasing Division and the Attorney General's office (Attorney General approval is as to form only). Any change to existing contracts that adds work or changes contract cost, and were not included in the original contract, must be approved by the Purchasing Division and the Attorney General's Office (as to form) prior to the implementation of the change or commencement of work affected by the change.

25. WAIVER: The failure of either party to insist upon a strict performance of any of the terms or provision of this Contract, or to exercise any option, right, or remedy herein contained, shall not be construed as a waiver or a relinquishment for the future of such term, provision, option, right, or remedy, but the same shall continue in full force and effect. Any waiver must be expressly stated in writing and signed by the waiving party.

26. SUBSEQUENT FORMS: The terms and conditions contained in this Contract shall supersede any and all subsequent terms and conditions which may appear on any form documents submitted by Vendor to the Agency or Purchasing Division such as price lists, order forms, invoices, sales agreements, or maintenance agreements, and includes internet websites or other electronic documents. Acceptance or use of Vendor's forms does not constitute acceptance of the terms and conditions contained thereon.

27. ASSIGNMENT: Neither this Contract nor any monies due, or to become due hereunder, may be assigned by the Vendor without the express written consent of the Agency, the Purchasing Division, the Attorney General's office (as to form only), and any other government agency or office that may be required to approve such assignments.

28. WARRANTY: The Vendor expressly warrants that the goods and/or services covered by this Contract will: (a) conform to the specifications, drawings, samples, or other description furnished or specified by the Agency; (b) be merchantable and fit for the purpose intended; and (c) be free from defect in material and workmanship.

29. STATE EMPLOYEES: State employees are not permitted to utilize this Contract for personal use and the Vendor is prohibited from permitting or facilitating the same.

30. PRIVACY, SECURITY, AND CONFIDENTIALITY: The Vendor agrees that it will not disclose to anyone, directly or indirectly, any such personally identifiable information or other confidential information gained from the Agency, unless the individual who is the subject of the information consents to the disclosure in writing or the disclosure is made pursuant to the Agency's policies, procedures, and rules. Vendor further agrees to comply with the Confidentiality Policies and Information Security Accountability Requirements, set forth in www.state.wv.us/admin/purchase/privacy.

31. YOUR SUBMISSION IS A PUBLIC DOCUMENT: Vendor's entire response to the Solicitation and the resulting Contract are public documents. As public documents, they will be disclosed to the public following the bid/proposal opening or award of the contract, as required by the competitive bidding laws of West Virginia Code §§ 5A-3-1 et seq., 5-22-1 et seq., and 5G-1-1 et seq. and the Freedom of Information Act West Virginia Code §§ 29B-1-1 et seq.

DO NOT SUBMIT MATERIAL YOU CONSIDER TO BE CONFIDENTIAL, A TRADE SECRET, OR OTHERWISE NOT SUBJECT TO PUBLIC DISCLOSURE.

Submission of any bid, proposal, or other document to the Purchasing Division constitutes your explicit consent to the subsequent public disclosure of the bid, proposal, or document. The Purchasing Division will disclose any document labeled "confidential," "proprietary," "trade secret," "private," or labeled with any other claim against public disclosure of the documents, to include any "trade secrets" as defined by West Virginia Code § 47-22-1 et seq. All submissions are subject to public disclosure without notice.

32. LICENSING: In accordance with West Virginia Code of State Rules § 148-1-6.1.e, Vendor must be licensed and in good standing in accordance with any and all state and local laws and requirements by any state or local agency of West Virginia, including, but not limited to, the West Virginia Secretary of State's Office, the West Virginia Tax Department, West Virginia Insurance Commission, or any other state agency or political subdivision. Obligations related to political subdivisions may include, but are not limited to, business licensing, business and occupation taxes, inspection compliance, permitting, etc. Upon request, the Vendor must provide all necessary releases to obtain information to enable the Purchasing Division Director or the Agency to verify that the Vendor is licensed and in good standing with the above entities.

SUBCONTRACTOR COMPLIANCE: Vendor shall notify all subcontractors providing commodities or services related to this Contract that as subcontractors, they too are required to be licensed, in good standing, and up-to-date on all state and local obligations as described in this section. Obligations related to political subdivisions may include, but are not limited to, business licensing, business and occupation taxes, inspection compliance, permitting, etc. Notification under this provision must occur prior to the performance of any work under the contract by the subcontractor.

33. ANTITRUST: In submitting a bid to, signing a contract with, or accepting a Award Document from any agency of the State of West Virginia, the Vendor agrees to convey, sell, assign, or transfer to the State of West Virginia all rights, title, and interest in and to all causes of action it may now or hereafter acquire under the antitrust laws of the United States and the State of West Virginia for price fixing and/or unreasonable restraints of trade relating to the particular commodities or services purchased or acquired by the State of West Virginia. Such assignment shall be made and become effective at the time the purchasing agency tenders the initial payment to Vendor.

34. VENDOR NON-CONFLICT: Neither Vendor nor its representatives are permitted to have any interest, nor shall they acquire any interest, direct or indirect, which would compromise the performance of its services hereunder. Any such interests shall be promptly presented in detail to the Agency.

35. VENDOR RELATIONSHIP: The relationship of the Vendor to the State shall be that of an independent contractor and no principal-agent relationship or employer-employee relationship is contemplated or created by this Contract. The Vendor as an independent contractor is solely liable for the acts and omissions of its employees and agents. Vendor shall be responsible for selecting, supervising, and compensating any and all individuals employed pursuant to the terms of this Solicitation and resulting contract. Neither the Vendor, nor any employees or subcontractors of the Vendor, shall be deemed to be employees of the State for any purpose whatsoever. Vendor shall be exclusively responsible for payment of employees and contractors for all wages and salaries, taxes, withholding payments, penalties, fees, fringe benefits, professional liability insurance premiums, contributions to insurance and pension, or other deferred compensation plans, including but not limited to, Workers' Compensation and Social Security obligations, licensing fees, etc. and the filing of all necessary documents, forms, and returns pertinent to all of the foregoing.

Vendor shall hold harmless the State, and shall provide the State and Agency with a defense against any and all claims including, but not limited to, the foregoing payments, withholdings, contributions, taxes, Social Security taxes, and employer income tax returns.

36. INDEMNIFICATION: The Vendor agrees to indemnify, defend, and hold harmless the State and the Agency, their officers, and employees from and against: (1) Any claims or losses for services rendered by any subcontractor, person, or firm performing or supplying services, materials, or supplies in connection with the performance of the Contract; (2) Any claims or losses resulting to any person or entity injured or damaged by the Vendor, its officers, employees, or subcontractors by the publication, translation, reproduction, delivery, performance, use, or disposition of any data used under the Contract in a manner not authorized by the Contract, or by Federal or State statutes or regulations; and (3) Any failure of the Vendor, its officers, employees, or subcontractors to observe State and Federal laws including, but not limited to, labor and wage and hour laws.

37. NO DEBT CERTIFICATION: In accordance with West Virginia Code §§ 5A-3-10a and 5-22-1(i), the State is prohibited from awarding a contract to any bidder that owes a debt to the State or a political subdivision of the State. By submitting a bid, or entering into a contract with the State, Vendor is affirming that (1) for construction contracts, the Vendor is not in default on any monetary obligation owed to the state or a political subdivision of the state, and (2) for all other contracts, neither the Vendor nor any related party owe a debt as defined above, and neither the Vendor nor any related party are in employer default as defined in the statute cited above unless the debt or employer default is permitted under the statute.

38. CONFLICT OF INTEREST: Vendor, its officers or members or employees, shall not presently have or acquire an interest, direct or indirect, which would conflict with or compromise the performance of its obligations hereunder. Vendor shall periodically inquire of its officers, members and employees to ensure that a conflict of interest does not arise. Any conflict of interest discovered shall be promptly presented in detail to the Agency.

39. REPORTS: Vendor shall provide the Agency and/or the Purchasing Division with the following reports identified by a checked box below:

Such reports as the Agency and/or the Purchasing Division may request. Requested reports may include, but are not limited to, quantities purchased, agencies utilizing the contract, total contract expenditures by agency, etc.

Quarterly reports detailing the total quantity of purchases in units and dollars, along with a listing of purchases by agency. Quarterly reports should be delivered to the Purchasing Division via email at purchasing.division@wv.gov.

40. BACKGROUND CHECK: In accordance with W. Va. Code § 15-2D-3, the State reserves the right to prohibit a service provider's employees from accessing sensitive or critical information or to be present at the Capitol complex based upon results addressed from a criminal background check. Service providers should contact the West Virginia Division of Protective Services by phone at (304) 558-9911 for more information.

41. PREFERENCE FOR USE OF DOMESTIC STEEL PRODUCTS: Except when authorized by the Director of the Purchasing Division pursuant to W. Va. Code § 5A-3-56, no contractor may use or supply steel products for a State Contract Project other than those steel products made in the United States. A contractor who uses steel products in violation of this section may be subject to civil penalties pursuant to W. Va. Code § 5A-3-56. As used in this section:

- a. "State Contract Project" means any erection or construction of, or any addition to, alteration of or other improvement to any building or structure, including, but not limited to, roads or highways, or the installation of any heating or cooling or ventilating plants or other equipment, or the supply of and materials for such projects, pursuant to a contract with the State of West Virginia for which bids were solicited on or after June 6, 2001.
- b. "Steel Products" means products rolled, formed, shaped, drawn, extruded, forged, cast, fabricated or otherwise similarly processed, or processed by a combination of two or more or such operations, from steel made by the open heath, basic oxygen, electric furnace, Bessemer or other steel making process.
- c. The Purchasing Division Director may, in writing, authorize the use of foreign steel products if:
 1. The cost for each contract item used does not exceed one tenth of one percent (.1%) of the total contract cost or two thousand five hundred dollars (\$2,500.00), whichever is greater. For the purposes of this section, the cost is the value of the steel product as delivered to the project; or
 2. The Director of the Purchasing Division determines that specified steel materials are not produced in the United States in sufficient quantity or otherwise are not reasonably available to meet contract requirements.

42. PREFERENCE FOR USE OF DOMESTIC ALUMINUM, GLASS, AND STEEL: In Accordance with W. Va. Code § 5-19-1 et seq., and W. Va. CSR § 148-10-1 et seq., for every contract or subcontract, subject to the limitations contained herein, for the construction, reconstruction, alteration, repair, improvement or maintenance of public works or for the purchase of any item of machinery or equipment to be used at sites of public works, only domestic aluminum, glass or steel products shall be supplied unless the spending officer determines, in writing, after the receipt of offers or bids, (1) that the cost of domestic aluminum, glass or steel products is unreasonable or inconsistent with the public interest of the State of West Virginia, (2) that domestic aluminum, glass or steel products are not produced in sufficient quantities to meet the contract requirements, or (3) the available domestic aluminum, glass, or steel do not meet the contract specifications. This provision only applies to public works contracts awarded in an amount more than fifty thousand dollars (\$50,000) or public works contracts that require more than ten thousand pounds of steel products.

The cost of domestic aluminum, glass, or steel products may be unreasonable if the cost is more than twenty percent (20%) of the bid or offered price for foreign made aluminum, glass, or steel products. If the domestic aluminum, glass or steel products to be supplied or produced in a "substantial labor surplus area", as defined by the United States Department of Labor, the cost of domestic aluminum, glass, or steel products may be unreasonable if the cost is more than thirty percent (30%) of the bid or offered price for foreign made aluminum, glass, or steel products. This preference shall be applied to an item of machinery or equipment, as indicated above, when the item is a single unit of equipment or machinery manufactured primarily of aluminum, glass or steel, is part of a public works contract and has the sole purpose or of being a permanent part of a single public works project. This provision does not apply to equipment or machinery purchased by a spending unit for use by that spending unit and not as part of a single public works project.

All bids and offers including domestic aluminum, glass or steel products that exceed bid or offer prices including foreign aluminum, glass or steel products after application of the preferences provided in this provision may be reduced to a price equal to or lower than the lowest bid or offer price for foreign aluminum, glass or steel products plus the applicable preference. If the reduced bid or offer prices are made in writing and supersede the prior bid or offer prices, all bids or offers, including the reduced bid or offer prices, will be reevaluated in accordance with this rule.

43. INTERESTED PARTY SUPPLEMENTAL DISCLOSURE: W. Va. Code § 6D-1-2 requires that for contracts with an actual or estimated value of at least \$1 million, the Vendor must submit to the Agency a disclosure of interested parties prior to beginning work under this Contract. Additionally, the Vendor must submit a supplemental disclosure of interested parties reflecting any new or differing interested parties to the contract, which were not included in the original pre-work interested party disclosure, within 30 days following the completion or termination of the contract. A copy of that form is included with this solicitation or can be obtained from the WV Ethics Commission. This requirement does not apply to publicly traded companies listed on a national or international stock exchange. A more detailed definition of interested parties can be obtained from the form referenced above.

44. PROHIBITION AGAINST USED OR REFURBISHED: Unless expressly permitted in the solicitation published by the State, Vendor must provide new, unused commodities, and is prohibited from supplying used or refurbished commodities, in fulfilling its responsibilities under this Contract.

45. VOID CONTRACT CLAUSES: This Contract is subject to the provisions of West Virginia Code § 5A-3-62, which automatically voids certain contract clauses that violate State law.

46. ISRAEL BOYCOTT: Bidder understands and agrees that, pursuant to W. Va. Code § 5A-3-63, it is prohibited from engaging in a boycott of Israel during the term of this contract.

DESIGNATED CONTACT: Vendor appoints the individual identified in this Section as the Contract Administrator and the initial point of contact for matters relating to this Contract.

(Printed Name and Title) Scott Wolf, Sales Manager
(Address) Dicke Tool Co., 1201 Warren Ave., Downers Grove, IL 60515
(Phone Number) / (Fax Number) 630-251-7545
(email address) scott@dicketool.com

CERTIFICATION AND SIGNATURE: By signing below, or submitting documentation through wvOASIS, I certify that: I have reviewed this Solicitation/Contract in its entirety; that I understand the requirements, terms and conditions, and other information contained herein; that this bid, offer or proposal constitutes an offer to the State that cannot be unilaterally withdrawn; that the product or service proposed meets the mandatory requirements contained in the Solicitation/Contract for that product or service, unless otherwise stated herein; that the Vendor accepts the terms and conditions contained in the Solicitation, unless otherwise stated herein; that I am submitting this bid, offer or proposal for review and consideration; that this bid or offer was made without prior understanding, agreement, or connection with any entity submitting a bid or offer for the same material, supplies, equipment or services; that this bid or offer is in all respects fair and without collusion or fraud; that this Contract is accepted or entered into without any prior understanding, agreement, or connection to any other entity that could be considered a violation of law; that I am authorized by the Vendor to execute and submit this bid, offer, or proposal, or any documents related thereto on Vendor's behalf; that I am authorized to bind the vendor in a contractual relationship; and that to the best of my knowledge, the vendor has properly registered with any State agency that may require registration.

By signing below, I further certify that I understand this Contract is subject to the provisions of West Virginia Code § 5A-3-62, which automatically voids certain contract clauses that violate State law; and that pursuant to W. Va. Code 5A-3-63, the entity entering into this contract is prohibited from engaging in a boycott against Israel.

Dicke Tool Company

(Company) _____

(Signature of Authorized Representative) _____

Scott Wolf, Sales Manager 3/22/2024

(Printed Name and Title of Authorized Representative) (Date) _____

630-251-7545

(Phone Number) (Fax Number) _____

scott@dicketool.com

(Email Address) _____

EXHIBIT C

36" OCTAGON - CORNER POCKET AND RIB CONFIGURATION

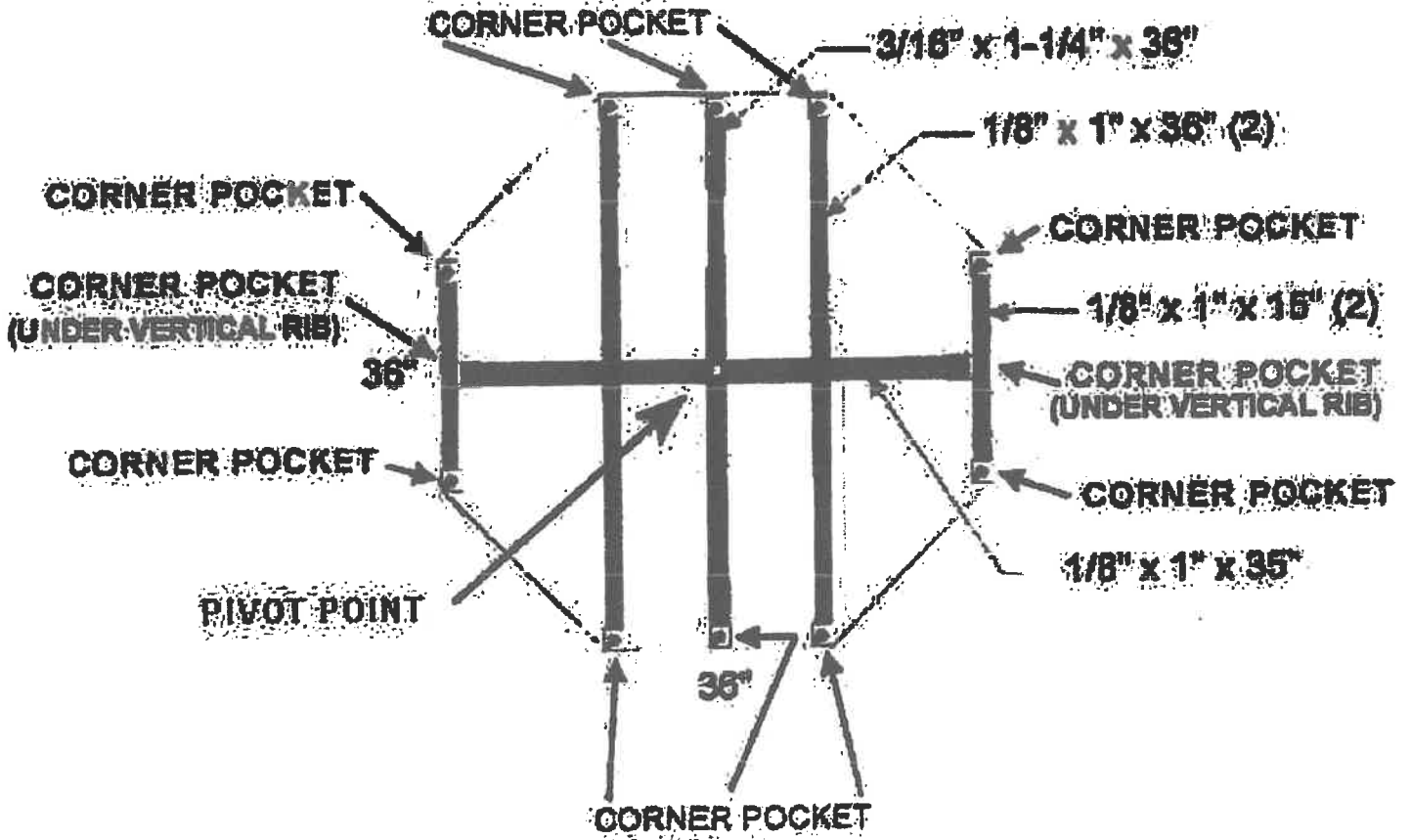

EXHIBIT D

48" OCTAGON - CORNER POCKET AND RIB CONFIGURATION

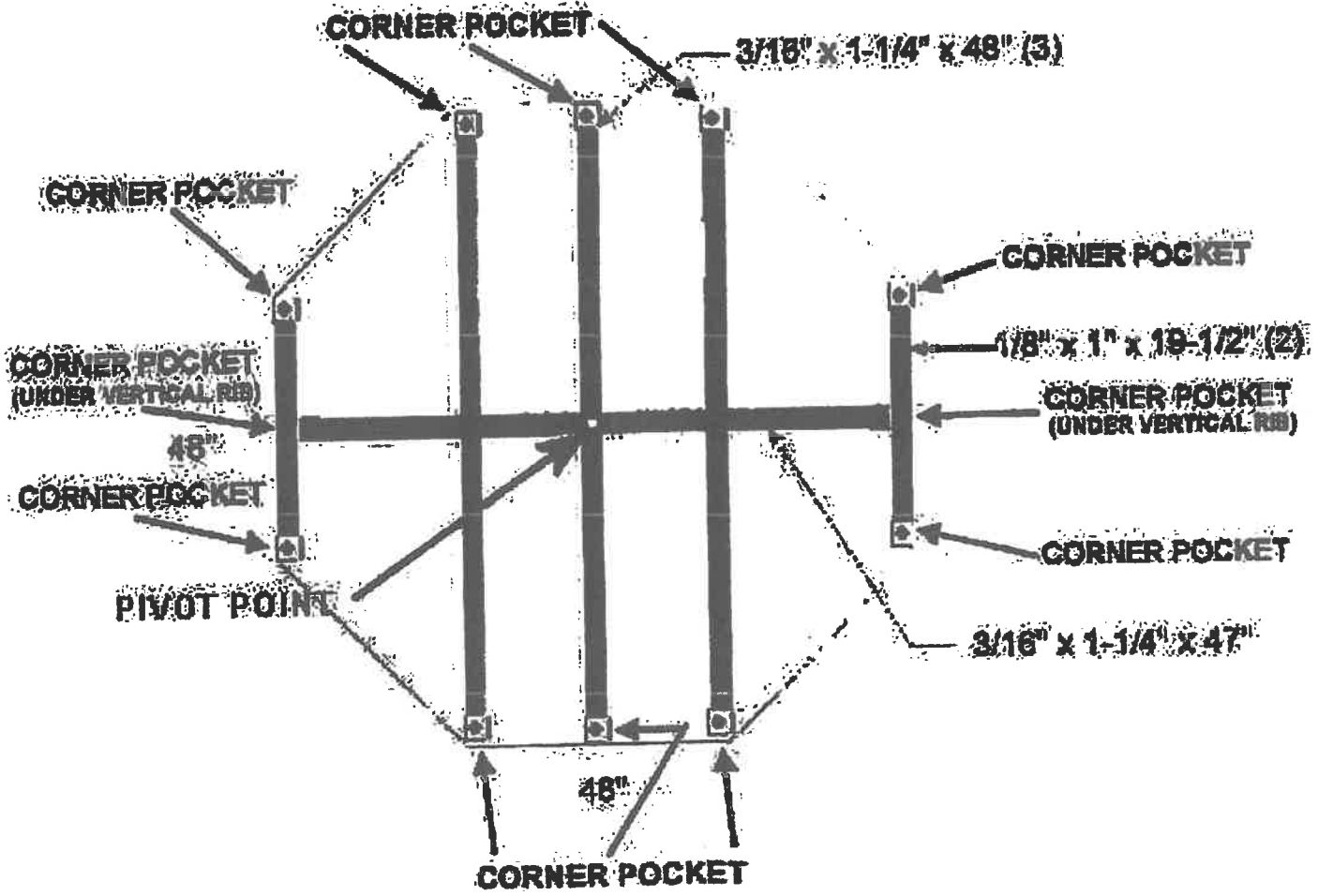

EXHIBIT E

36" DIAMOND - CORNER POCKET AND RIB CONFIGURATION

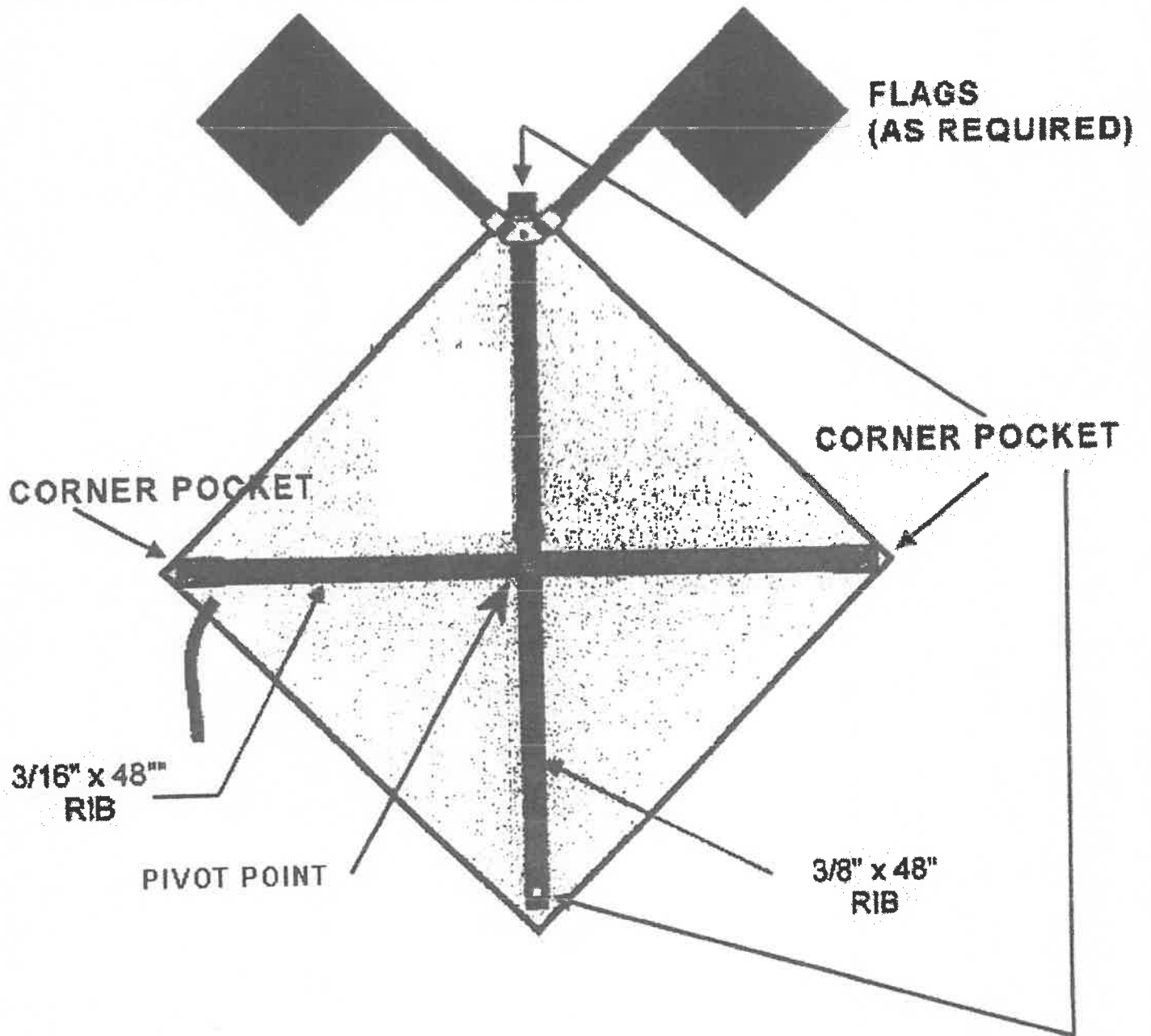

EXHIBIT F

48x48 DIAMOND - CORNER POCKET AND RIB CONFIGURATION

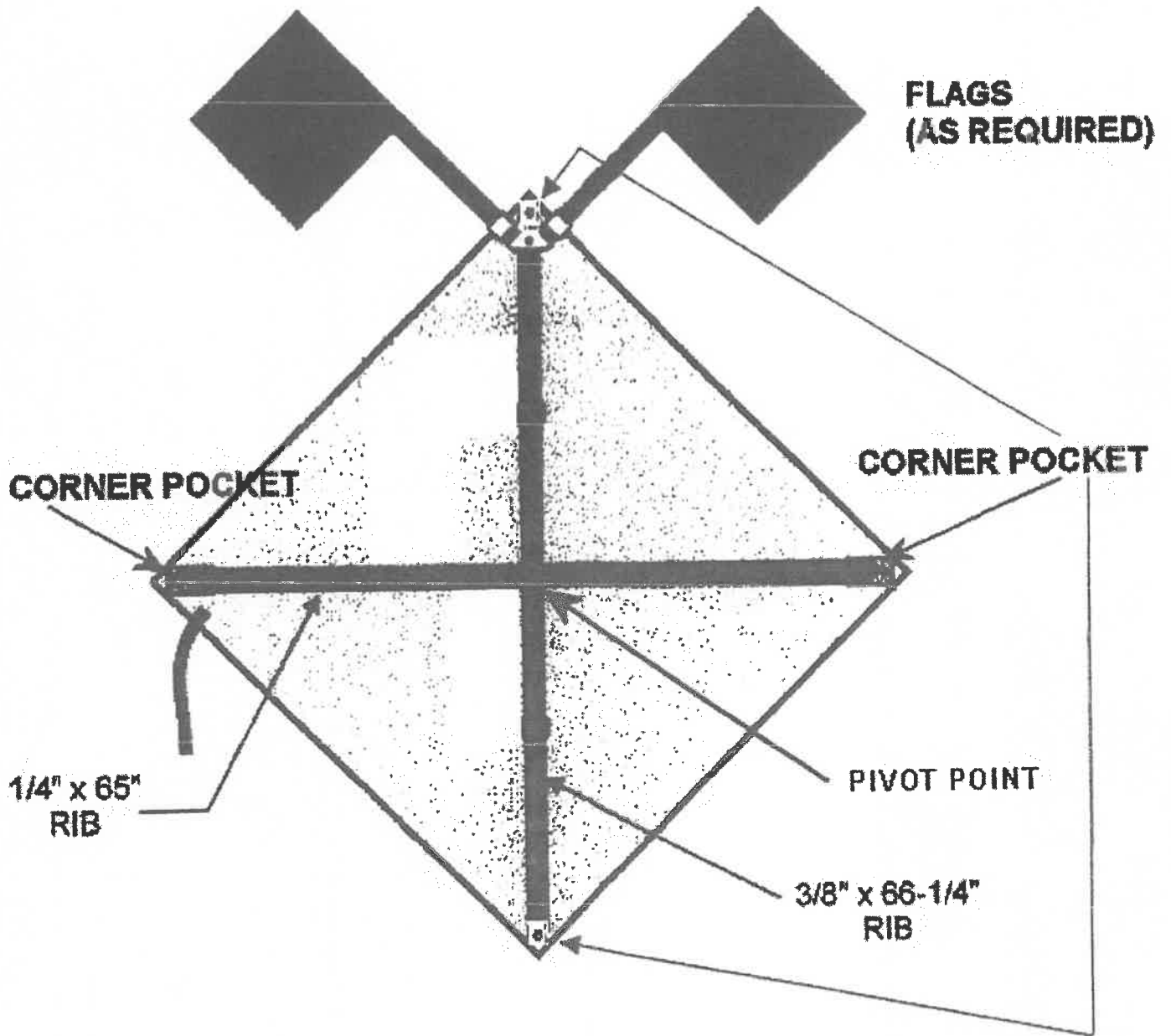

EXHIBIT G

36" TRIANGLE - CORNER POCKET AND RIB CONFIGURATION

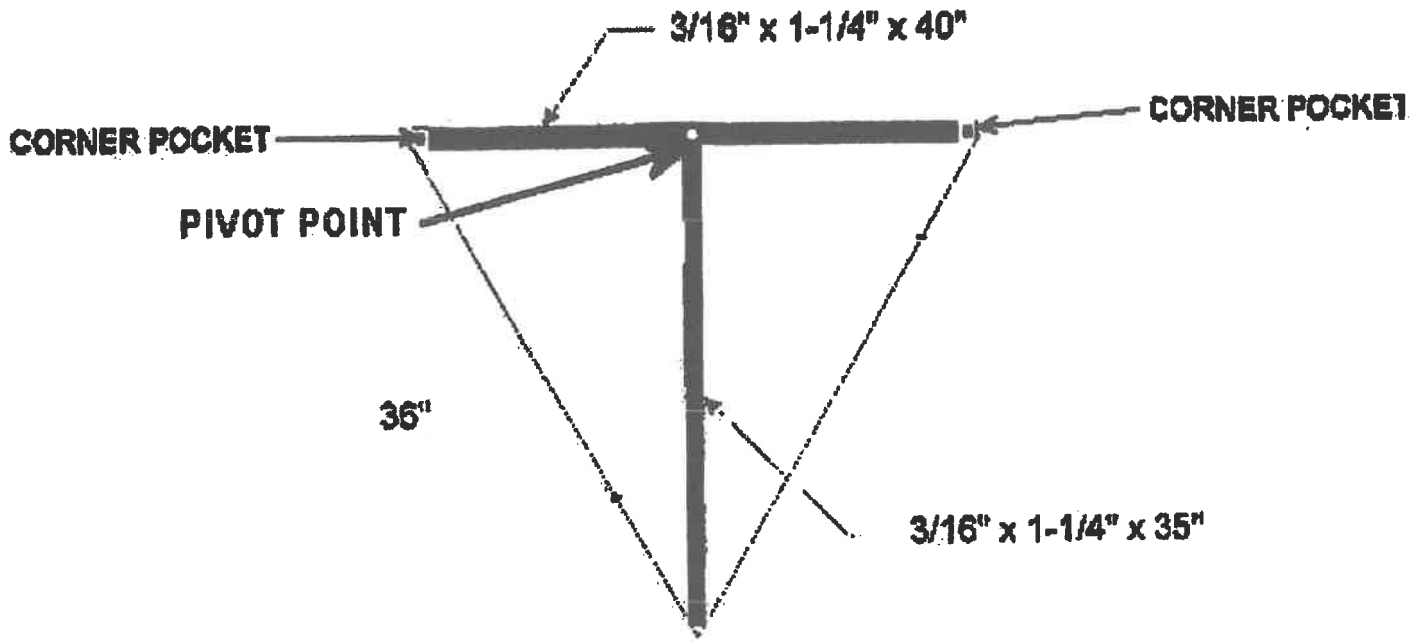

EXHIBIT H

48" TRIANGLE - CORNER POCKET AND RIB CONFIGURATION

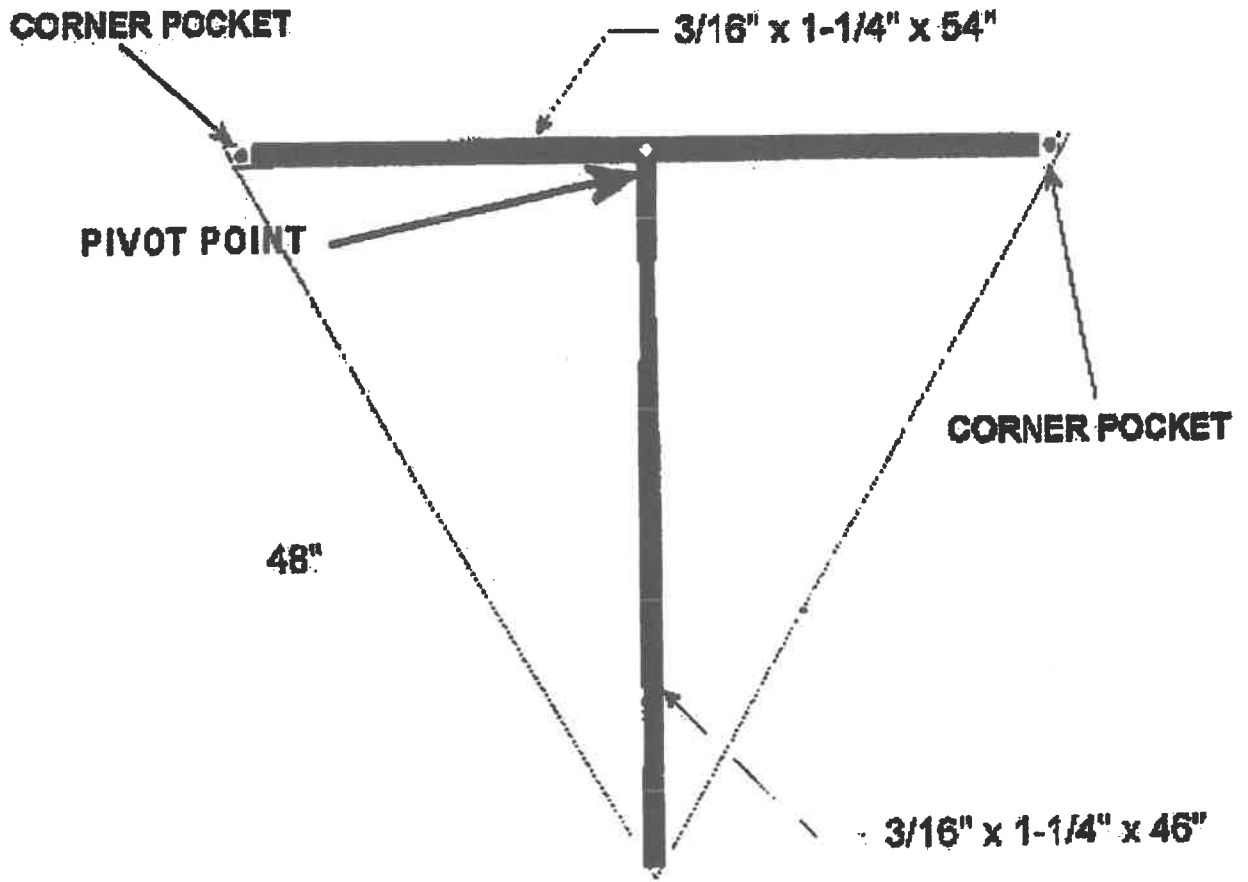
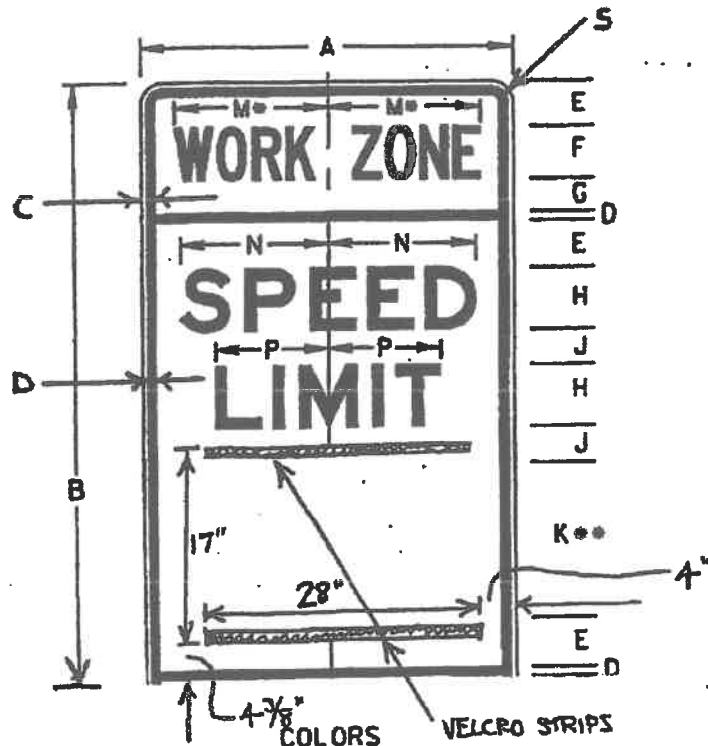

EXHIBIT I
 BID ITEM 9 - MODIFIED STANDARD DETAIL



TOP
 LEGEND - BLACK (NON-REF)
 BACKGROUND - ORANGE (REF)
 MIDDLE BACKGROUND - WHITE (REF)

DIMENSIONS (INCHES)

A	B	C	D	E	F	G	H	J	K	M	N	P	S
36	60	5/8	3/8	4 1/2	5C	3 3/8	6E	3 1/2	15E	14 7/8	14 5/16	10 5/8	1 5/8

• - REDUCE SPACING 50%

EXHIBIT J

**36x60 VERTICAL RECTANGLE -
CORNER POCKET AND RIB CONFIGURATION**

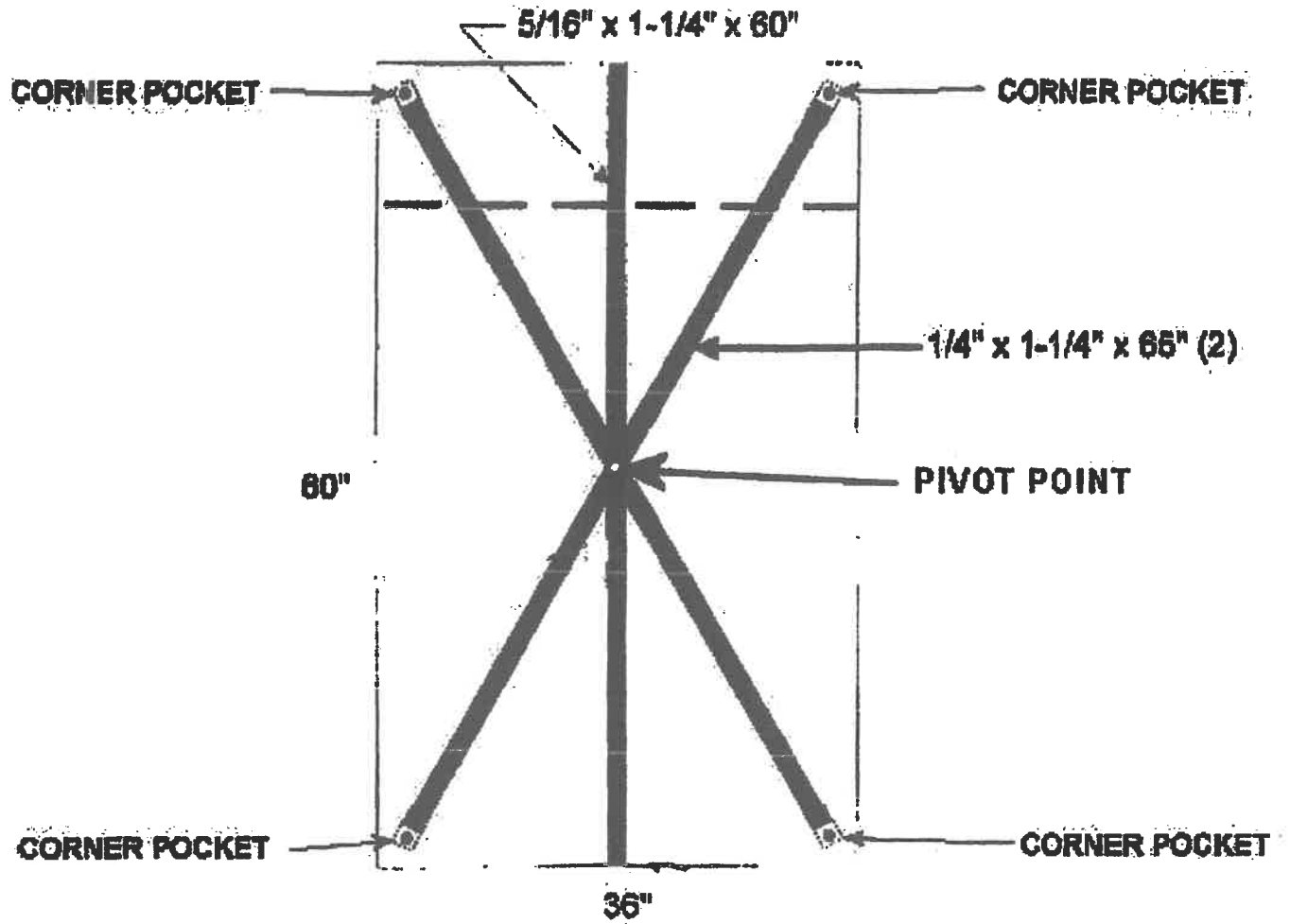
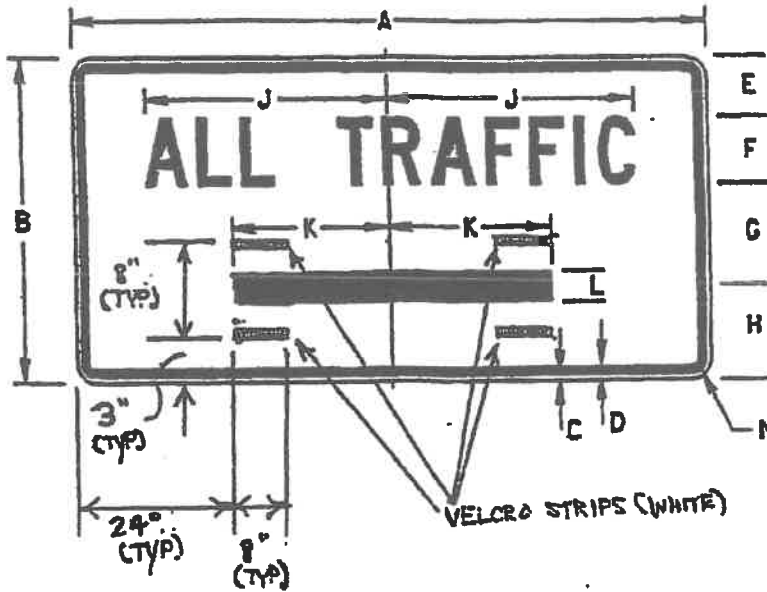

EXHIBIT K

BID ITEM 11 - MODIFIED STANDARD DETAIL



COLOR
 LEGEND - BLACK (NON-REF)
 BACKGROUND - WHITE (REF)

DIMENSIONS (INCHES)

A	B	C	D	E	F	G	H	J	K	L	M	N
4B	24	$\frac{3}{8}$	$\frac{5}{8}$	$4\frac{1}{2}$	5C	$7\frac{1}{2}$	7	$1B\frac{3}{16}$	12	$2\frac{1}{4}$		$1\frac{1}{8}$

ARROW DETAIL

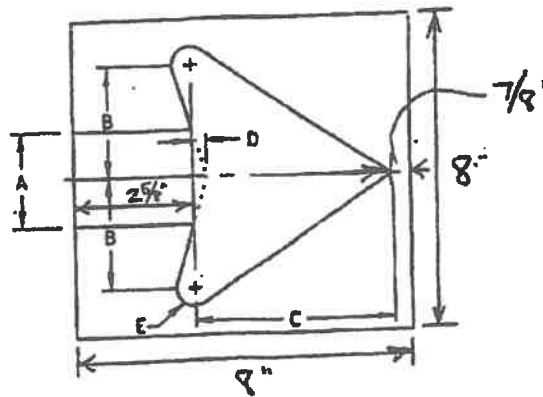

A	B	C	D	E
$2\frac{1}{4}$	$2\frac{3}{8}$	$4\frac{1}{2}$	$\frac{3}{8}$	$\frac{3}{8}$

EXHIBIT L

**48X24 HORIZONTAL RECTANGLE -
CORNER POCKET AND RIB CONFIGURATION**

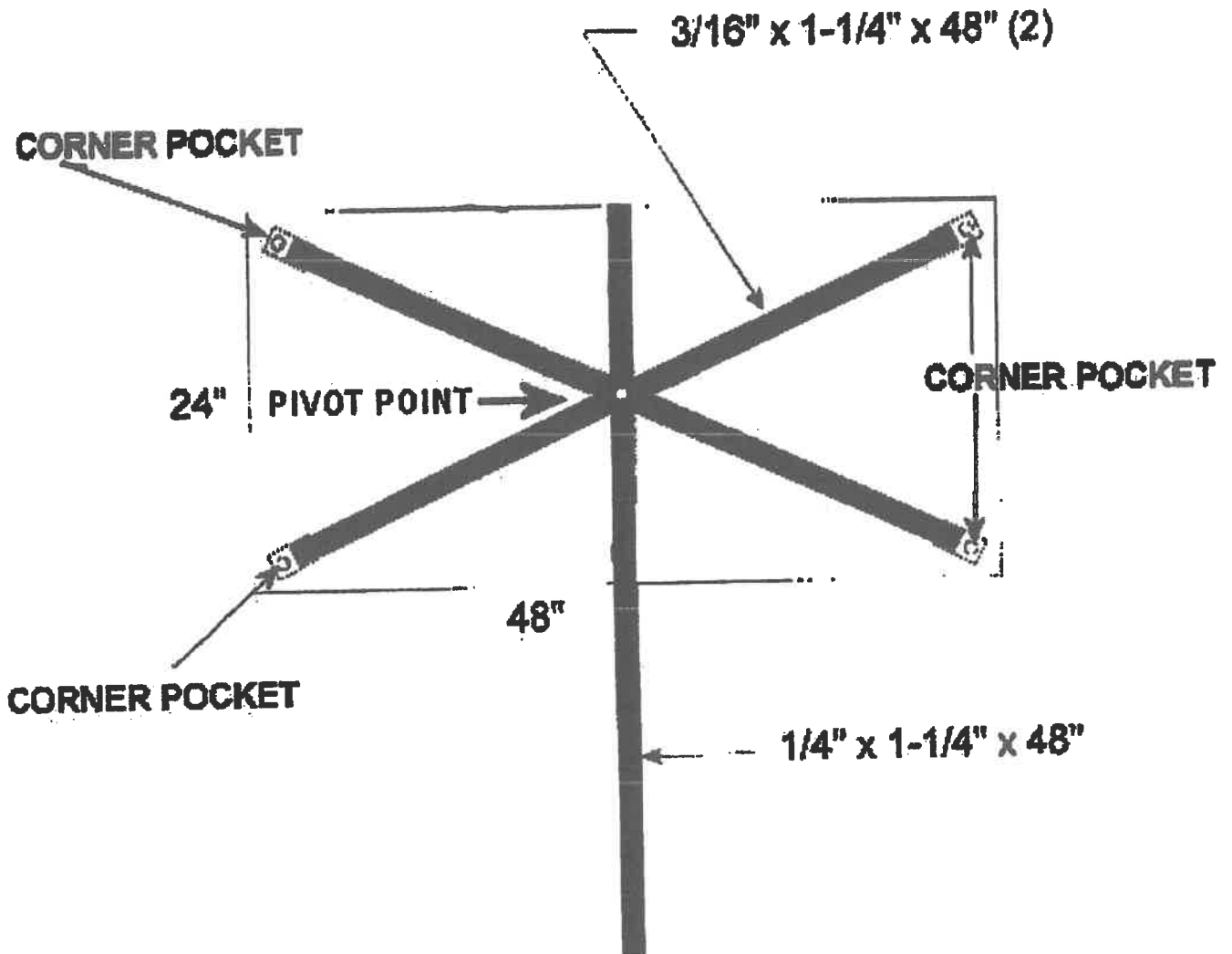

EXHIBIT M

24X30 VERTICAL RECTANGLE -
CORNER POCKET AND RIB CONFIGURATION

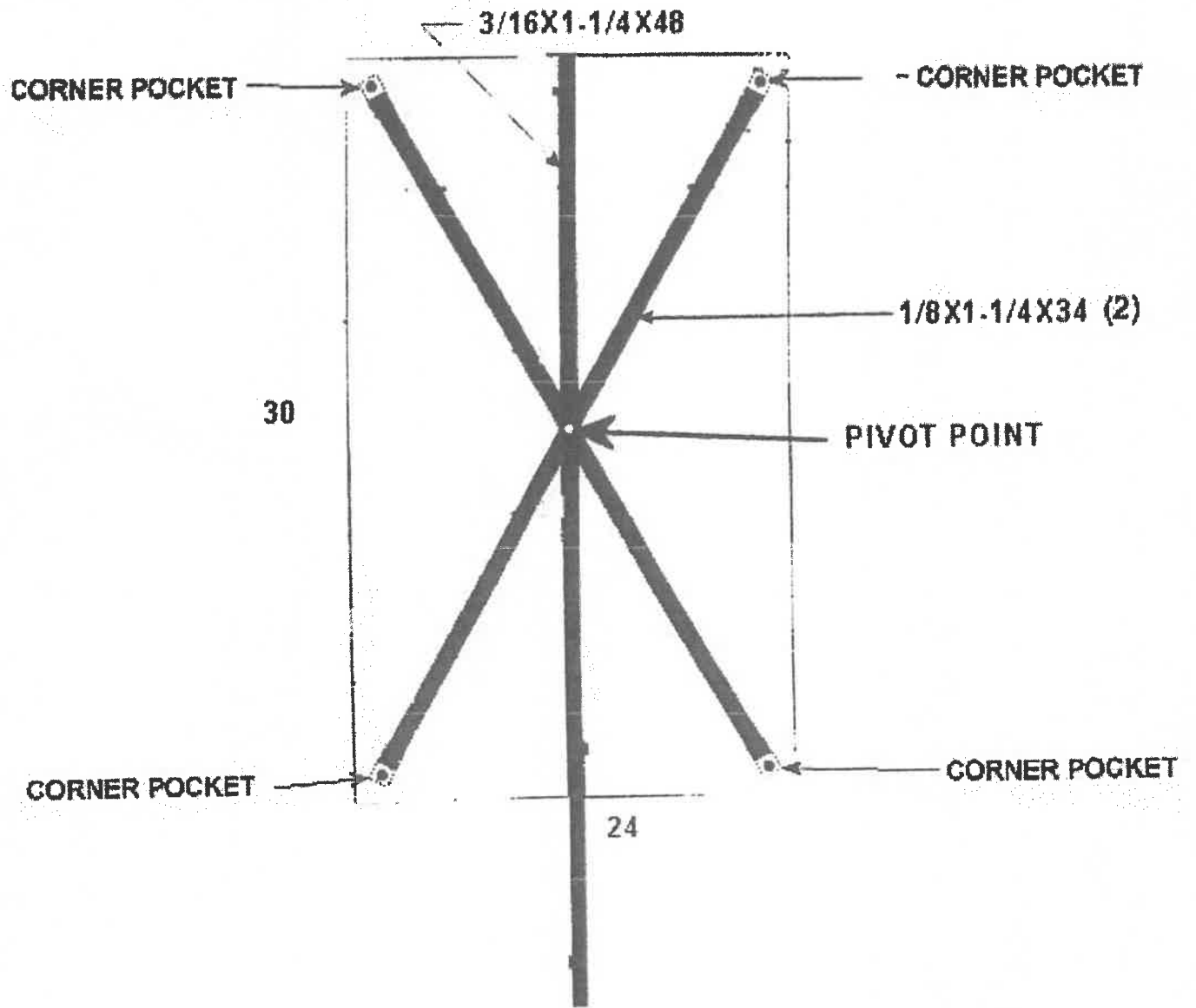
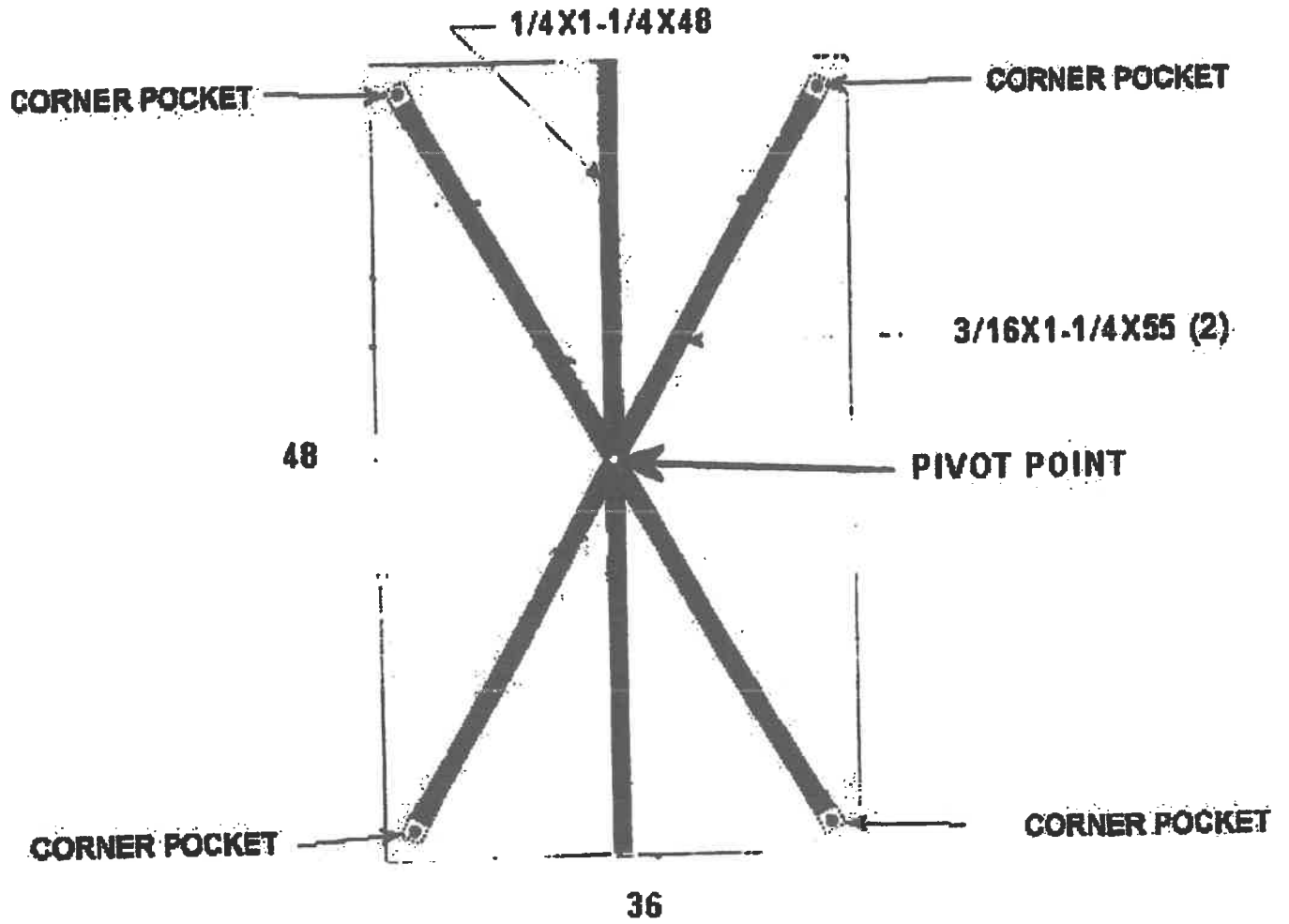

EXHIBIT N

**36X48 VERTICAL RECTANGLE -
CORNER POCKET AND RIB CONFIGURATION**



30X18 HORIZONTAL RECTANGLE - CORNER POCKET AND RIB CONFIGURATION

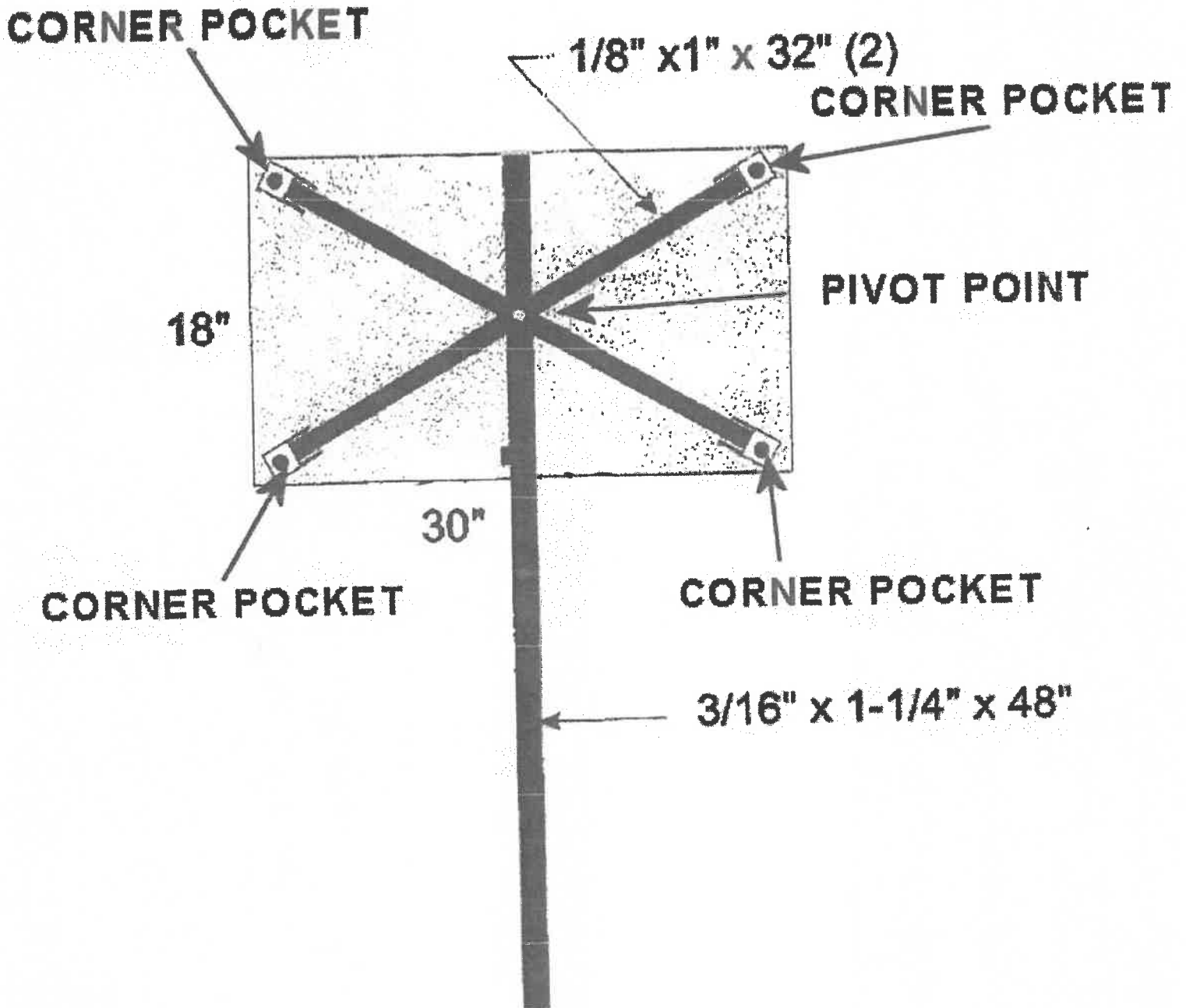

EXHIBIT Z

BID ITEM 24 - MODIFIED STANDARD DETAIL

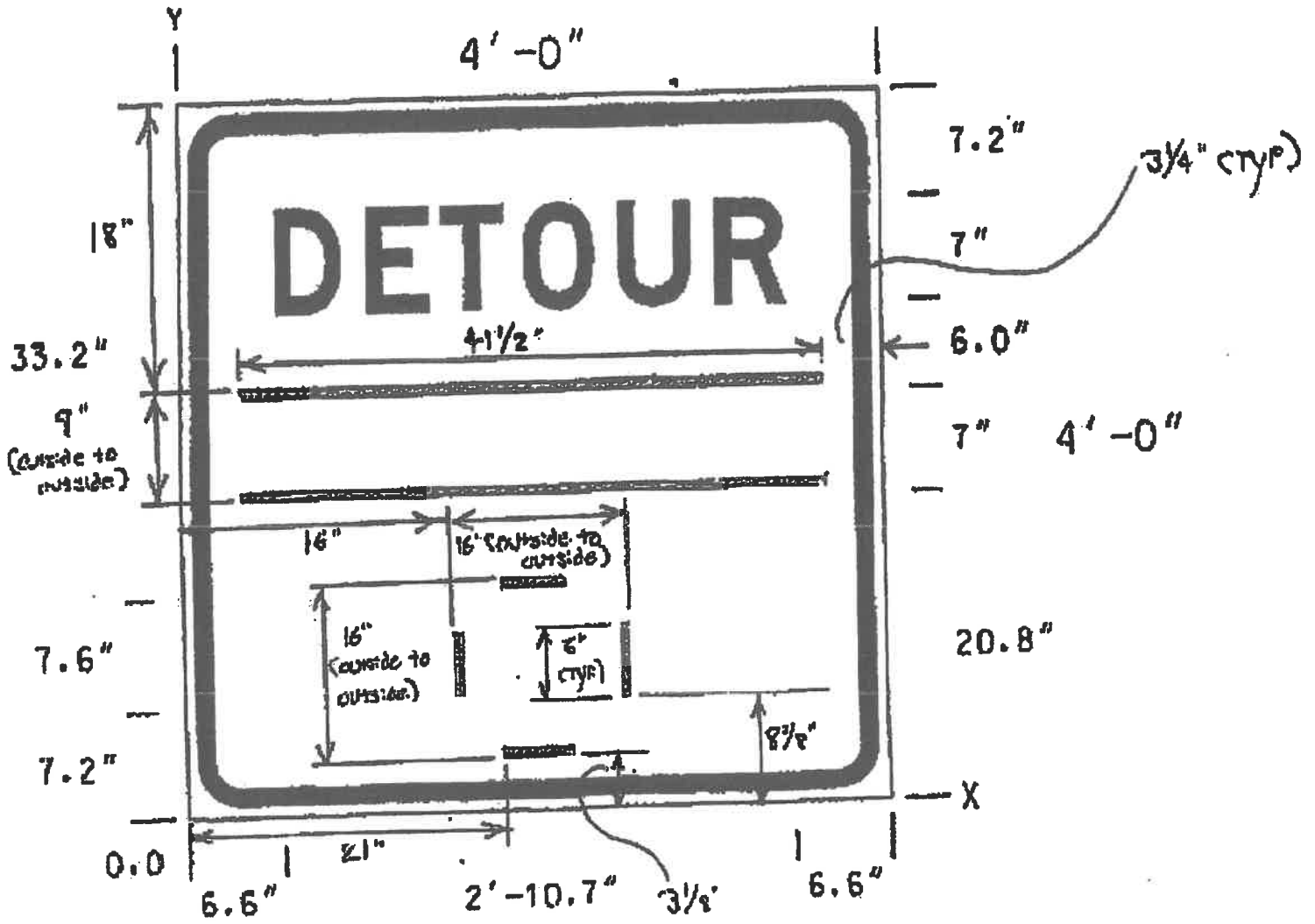

EXHIBIT P
BID ITEM 15 - MODIFIED STANDARD DETAIL



COLORS
LEGEND - BLACK (NON-REF)
BACKGROUND - WHITE (REF)

DIMENSIONS (INCHES)

A	B	C	D	E	F	G	H	J	K	L
48	30	1/2	3/4	5	8D	4	3 1/4	13 1/2	19	1 3/8

EXHIBIT Q

**48x30 HORIZONTAL RECTANGLE -
CORNER POCKET AND RIB CONFIGURATION**

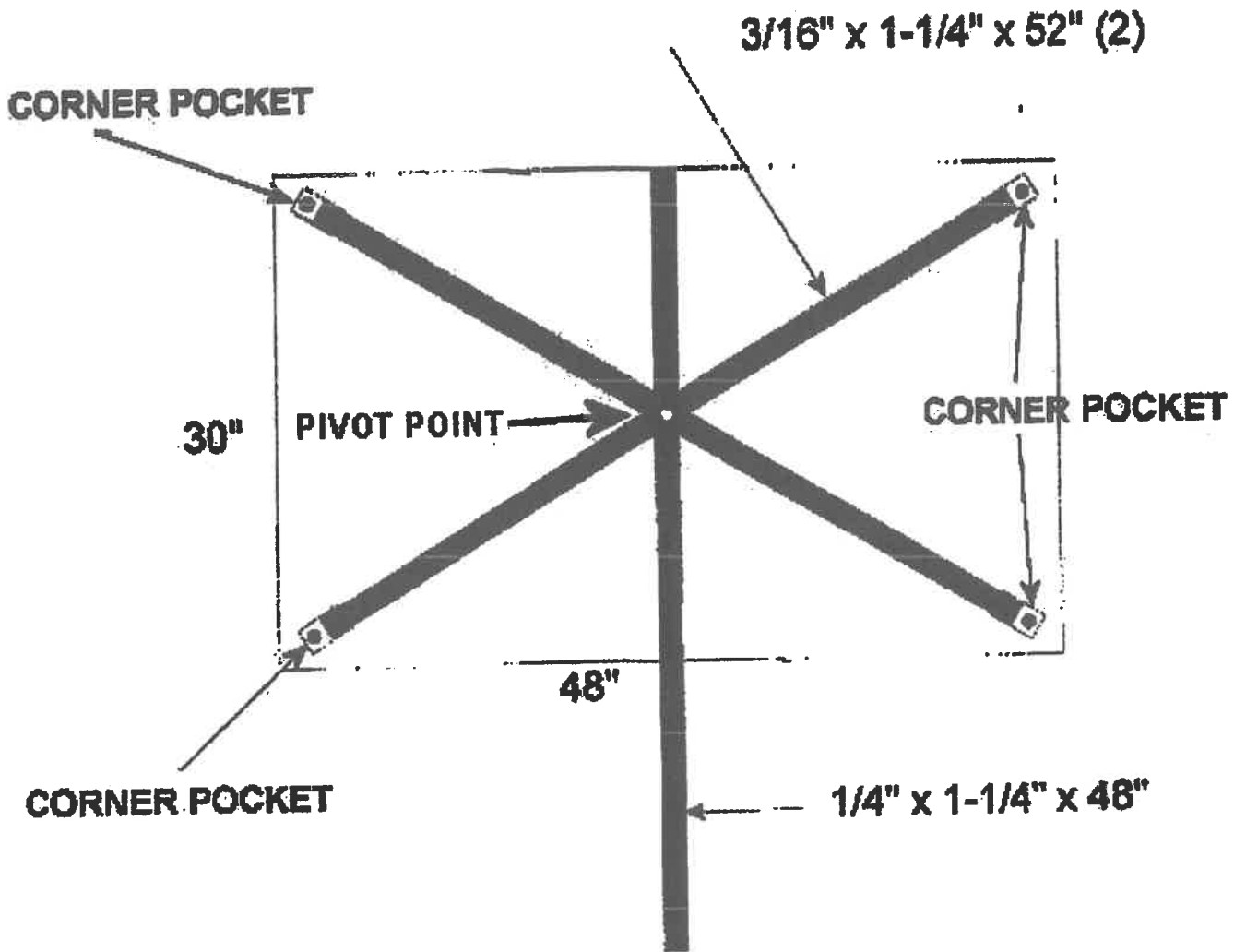
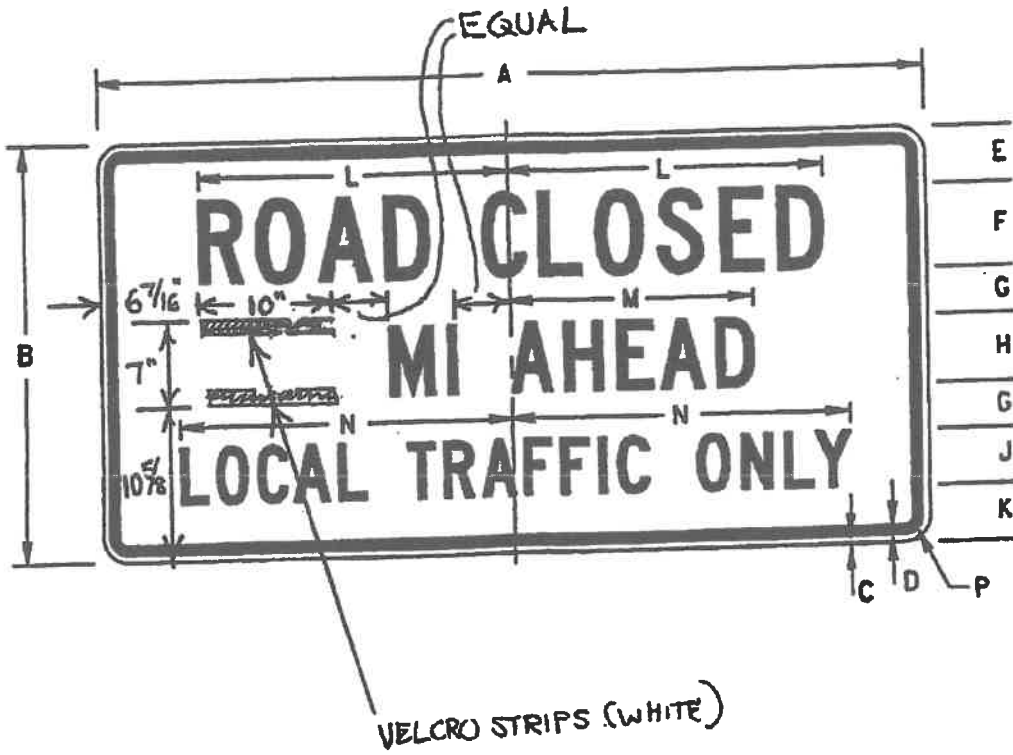

EXHIBIT R

BID ITEM 17 - MODIFIED STANDARD DETAIL



COLORS
 LEGEND - BLACK (NON-REF)
 BACKGROUND - WHITE (REF)

DIMENSIONS (INCHES)

A	B	C	D	E	F	G	H	J	K	L	M	N	P
60	30	1/2	3/4	4	6C	3 3/8	5C	4C	4 1/4	22 3/8	17 3/8	24 5/8	1 3/8

EXHIBIT S

**60X30 HORIZONTAL RECTANGLE -
CORNER POCKET AND RIB CONFIGURATION**

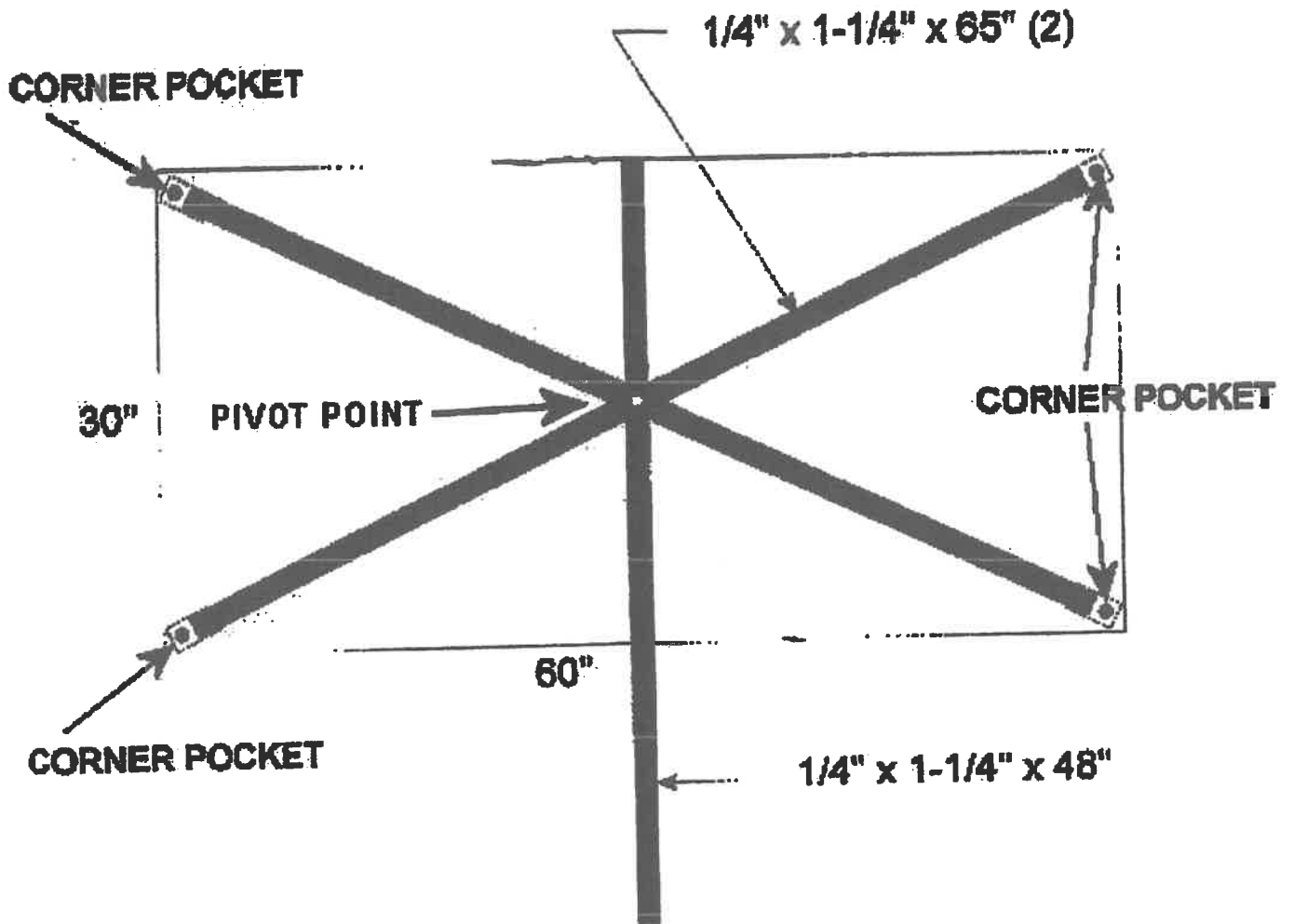
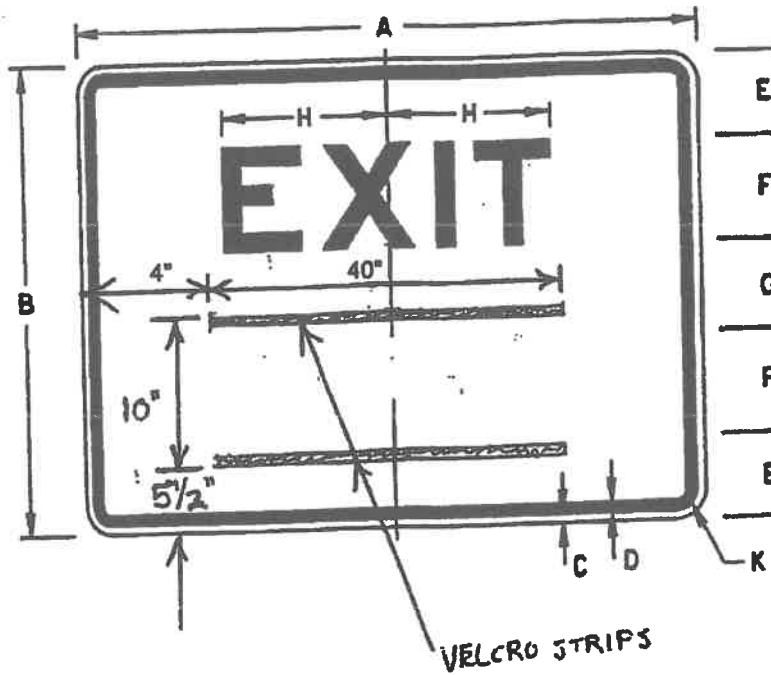

EXHIBIT T

BID ITEM 20 MODIFIED STANDARD DETAIL



COLORS
 LEGEND - BLACK (NON-REF)
 BACKGROUND - ORANGE (REF)

DIMENSIONS (INCHES)

A	B	C	D	E	F	G	H	"	K
48	36	5/8	7/8	6 1/2	BE	7	12 3/16	:	1 5/8

EXHIBIT U

**48x36 HORIZONTAL RECTANGLE -
CORNER POCKET AND RIB CONFIGURATION**

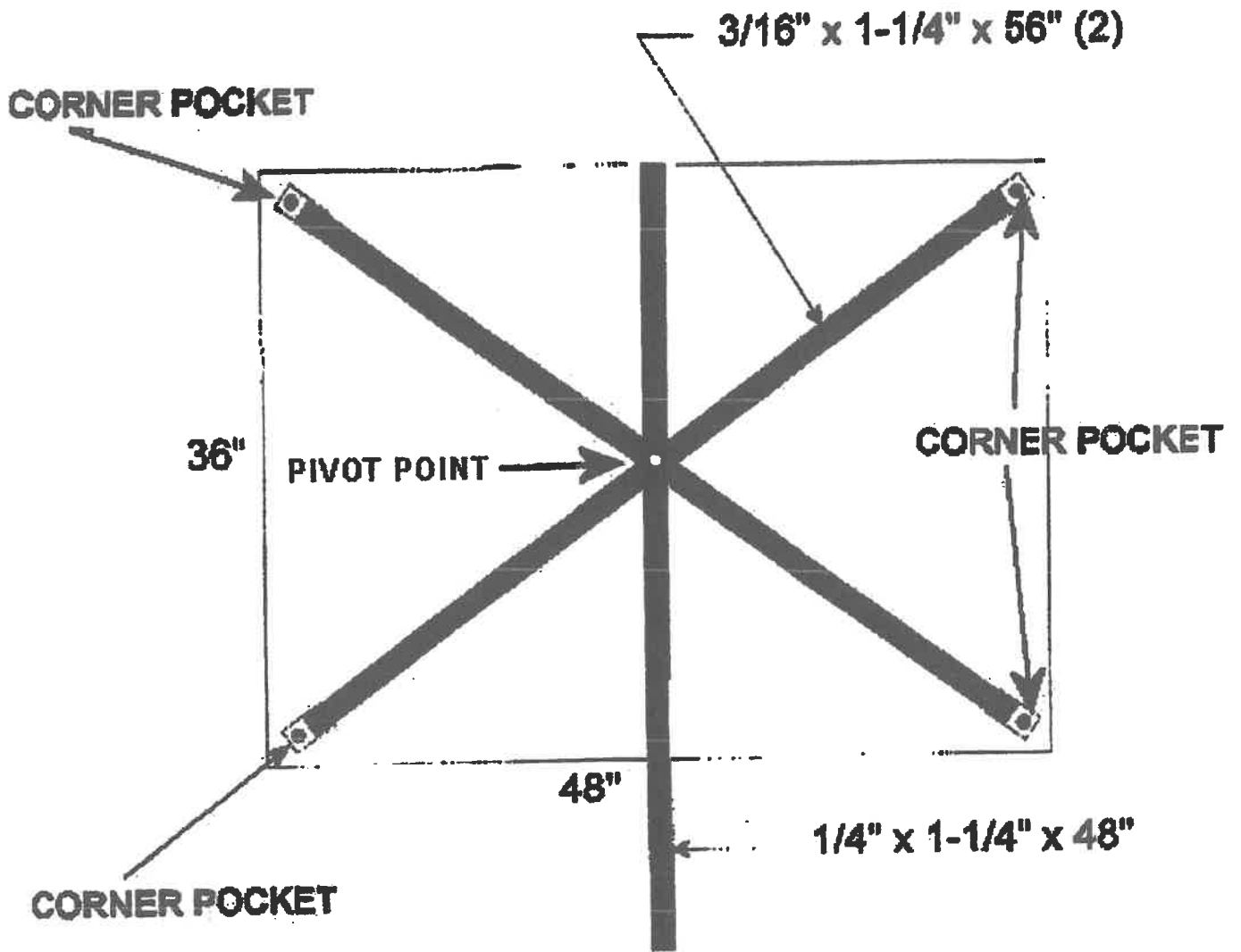

EXHIBIT V

60X60 SQUARE - CORNER POCKET AND RIB CONFIGURATION

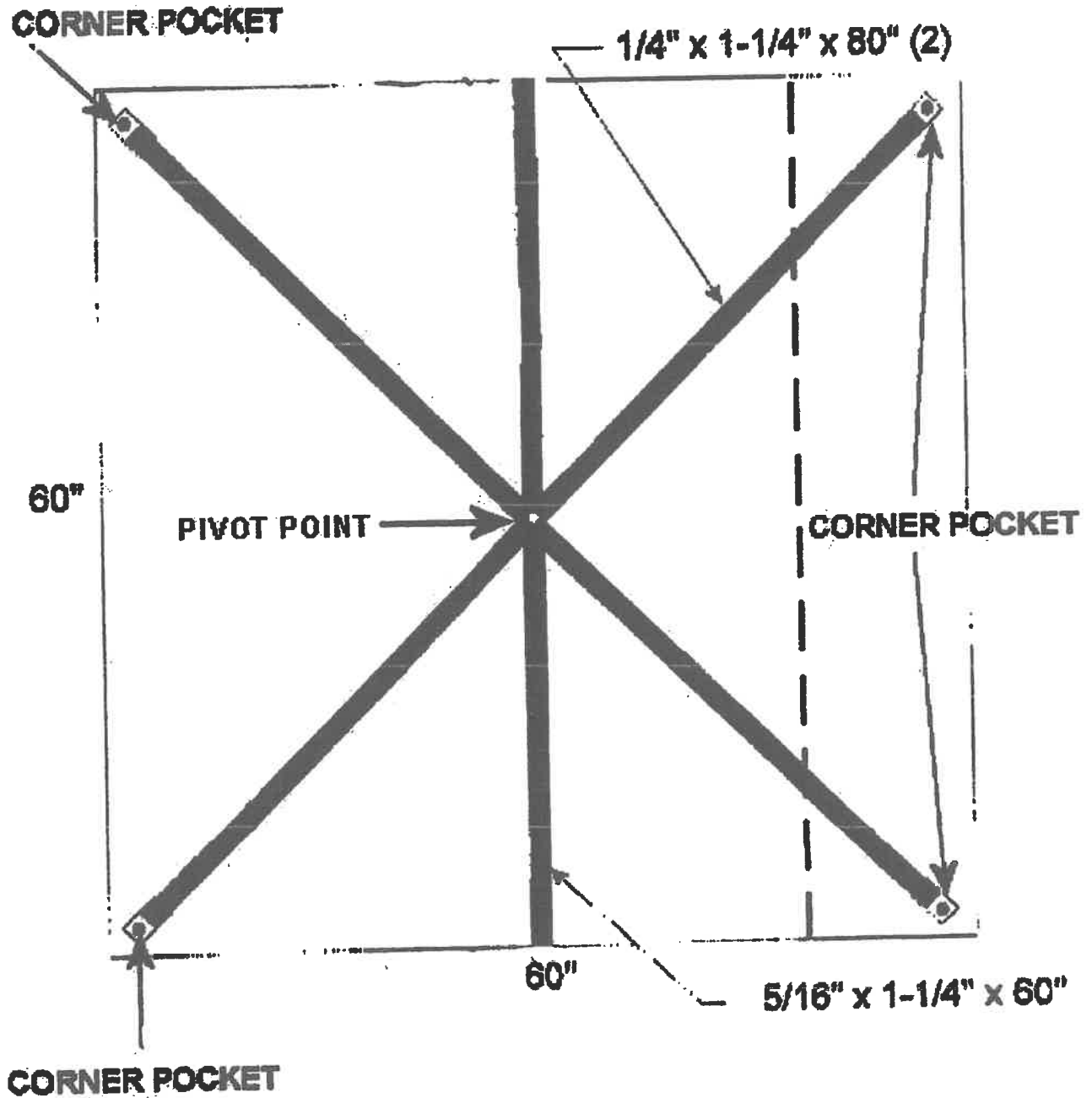
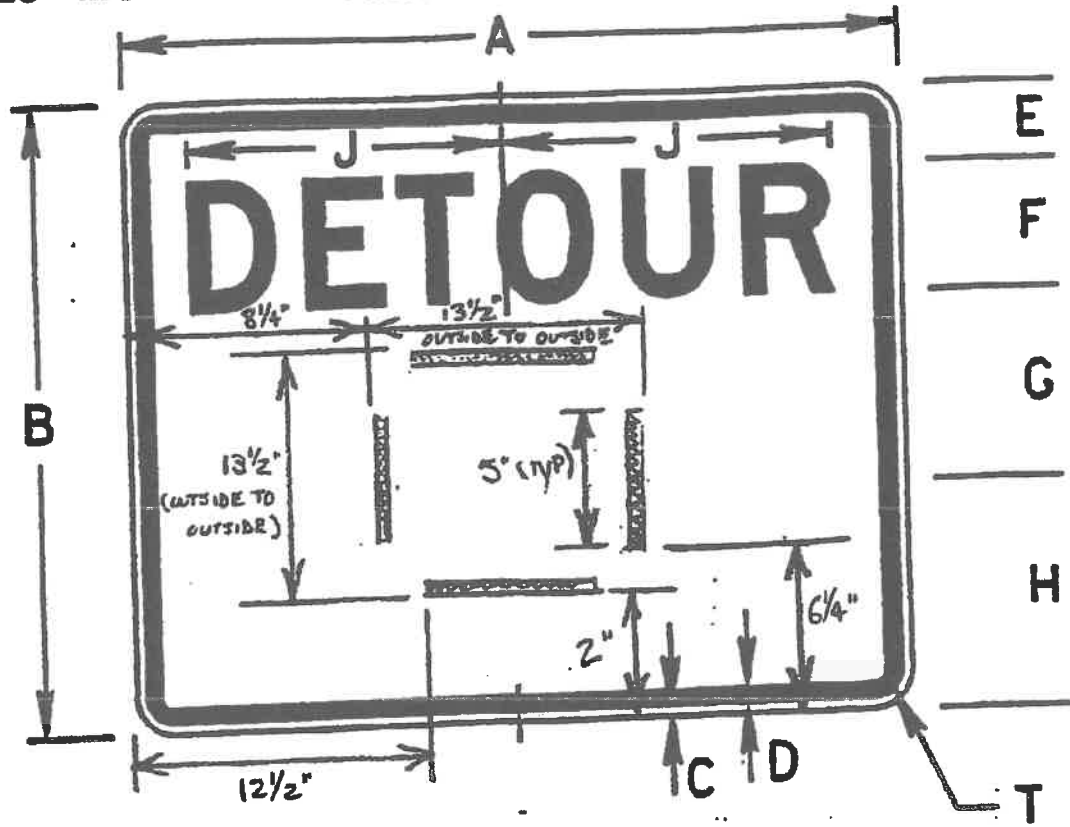

EXHIBIT W

BID ITEM 23 MODIFIED STANDARD DETAIL



COLORS
 LEGEND - BLACK (NON-REF)
 BACKGROUND - ORANGE (REF)
 DIMENSIONS (INCHES)

A	B	C	D	E	F	G	H	J	M	N	P	O	R	S	T
30	24	3/8	5/8	3	5D	7 1/4	8 3/4	2 7/8	5	1	12 1/2	2 1/2	3	10	1 1/8

EXHIBIT X

BID ITEM 23 - MODIFIED STANDARD DETAIL (CONTINUED)

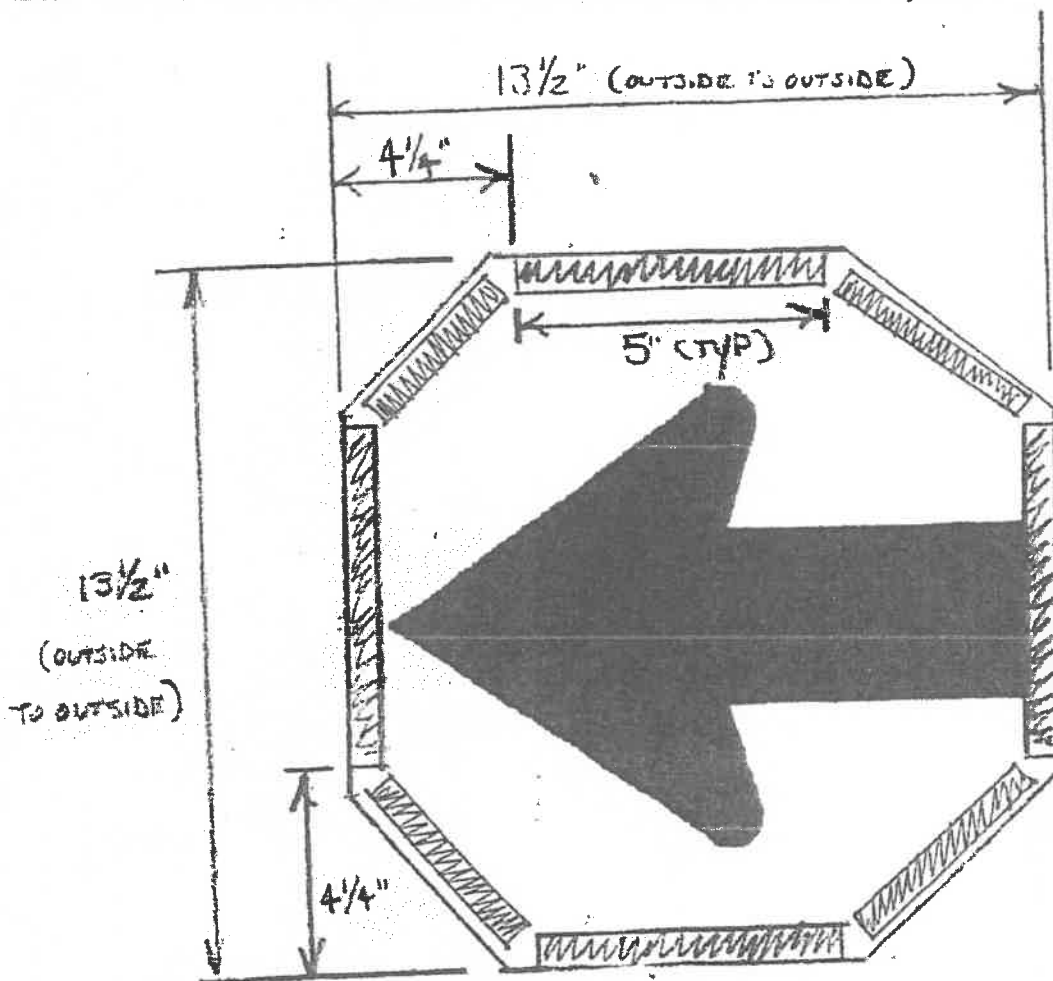

ARROW DETAIL

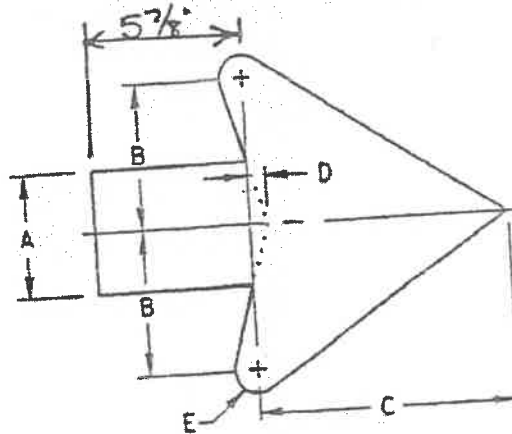

A	B	C	D	E
3/4	3/4	6 5/8	1/2	5/8

EXHIBIT Y

**30X24 HORIZONTAL RECTANGLE -
CORNER POCKET AND RIB CONFIGURATION**

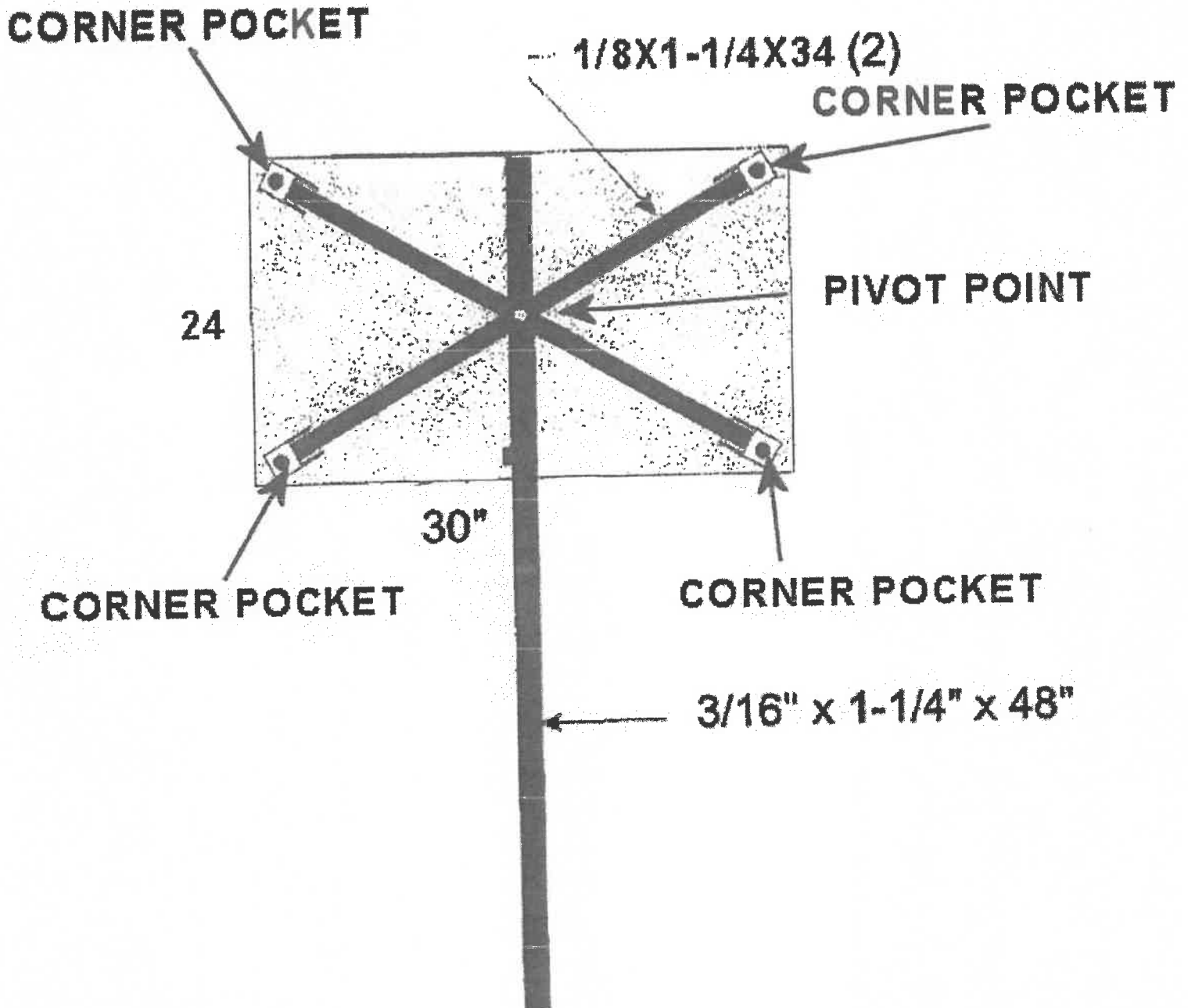
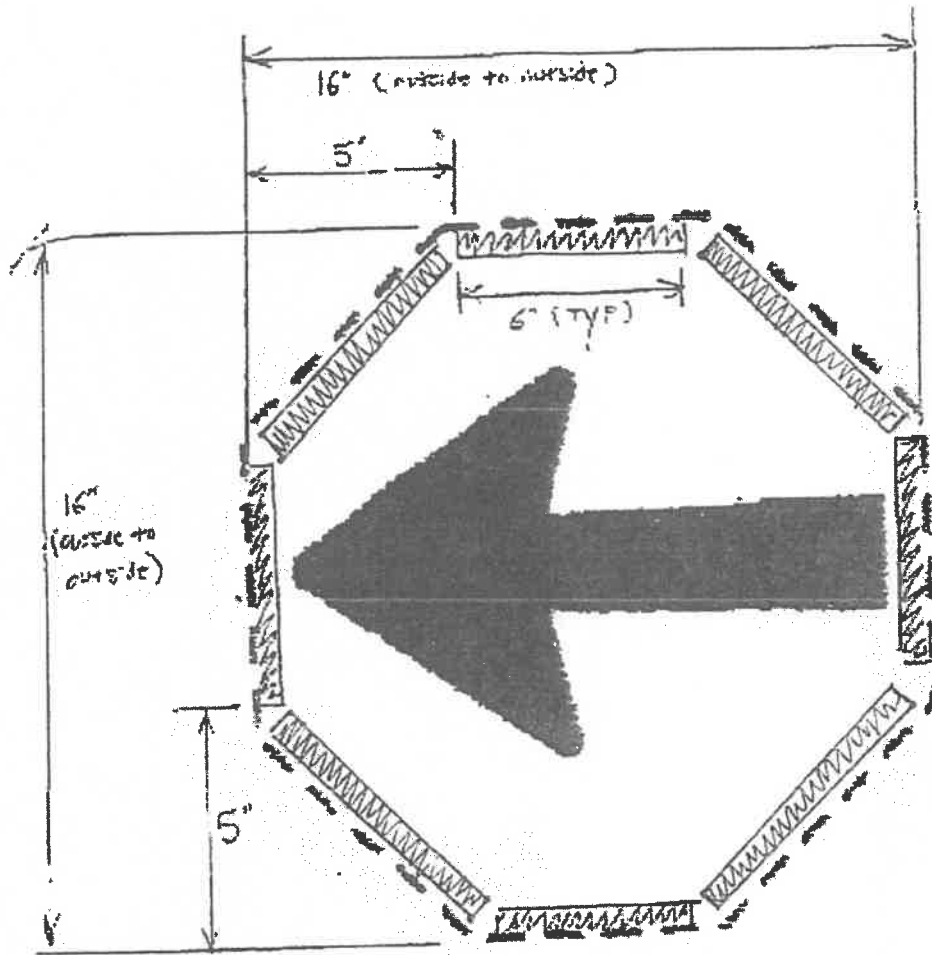
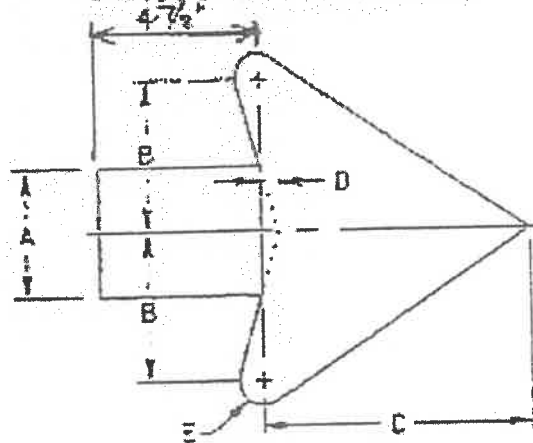

EXHIBIT AA

BID ITEM 24 - MODIFIED STANDARD DETAIL (CONTINUED)



ARROW DETAIL



A	B	C	D	E
3 1/2	4	7 7/8	9/16	1/8

EXHIBIT BB

48x48 SQUARE - CORNER POCKET AND RIB CONFIGURATION

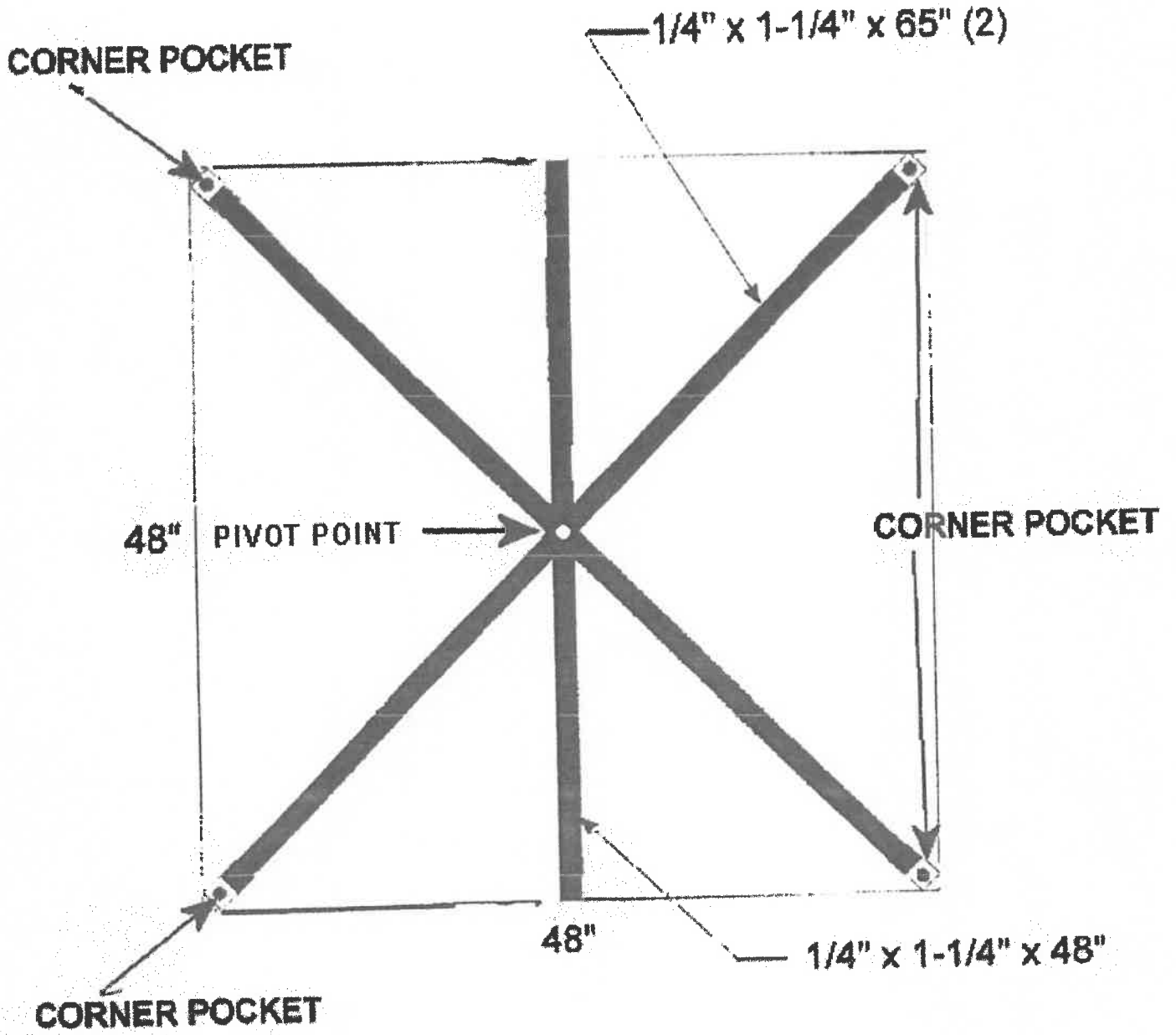

36X18 HORIZONTAL RECTANGLE - CORNER POCKET AND RIB CONFIGURATION

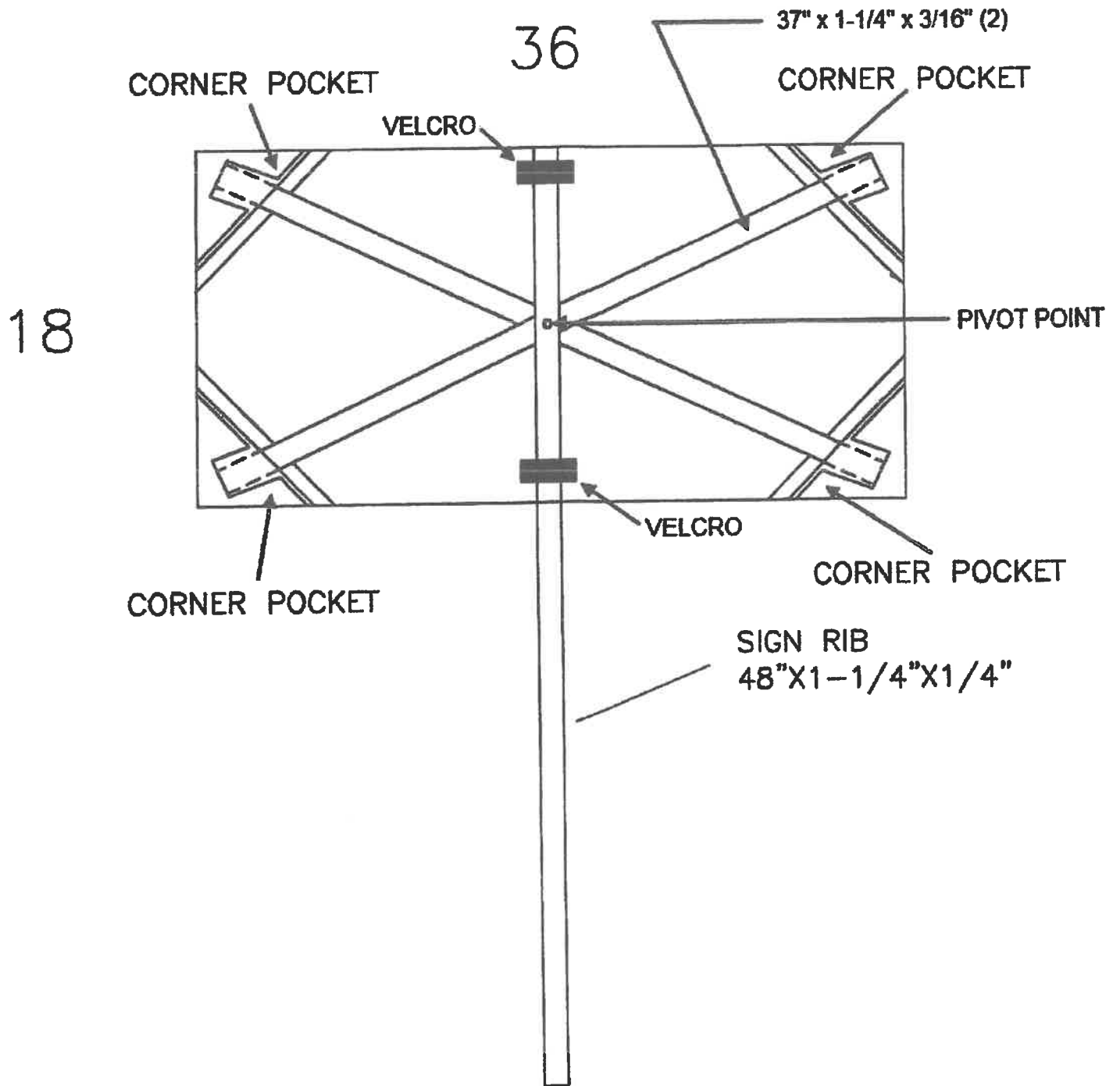

PRODUCT COMPLIANCE CHECKLIST FORM

This form shall be completed in its' entirety by the vendor, and submitted as part of the vendor's bid package.

1) Sign manufacturer: Dicke Tool Company

2) Sheeting manufacturer and product code for sheeting being used: Orafol Marathon Type VI, Superbright (Pink) Type VI

3) Manufacturer's handling and manufacturing methods are in compliance with the sheeting manufacturer's recommendations?

Yes	No
X	

4) In cases where the splicing of roll-up sign material fabric is required as noted within the Contract specifications, the splice is to be accomplished by the method described within the Contract specifications?

Yes	No
X	

5) All vertical, horizontal, or diagonal ribs designed to pivot about a metallic (rivet) pivot point meeting the specifications herein?

Yes	No
X	

6) With the exception of signs having a vertical rib extending below the sign, the ends of the ribs on all signs to slide into a cloth pocket meeting the material, manufacturing, and dimensional requirements contained herein?

Yes	No
X	

7) Vertical ribs of all non-diamond signs (excluding stop signs) to be attached and secured to signs using Hook & Loop material as described herein when specified?

Yes	No
X	

8) All metal parts of the vinyl flag deployment system, when required, to be stainless steel, electro-deposit zinc coated steel, hot-dip galvanized steel, or powder coated steel?

Yes	No
X	

9) Flag staffs shall be 1/8" thick x 1" wide fiberglass ribs.

Yes	No
X	

10) Flag staffs sufficiently long enough to hold the flags completely above the sign face?

Yes	No
X	

11) No hand tightening of any components required to hold the flags in the deployed position?

Yes	No
X	

12) When deployed, the two flags extend symmetrically (about the vertical centerline) up and out from their mounting point along the vertical rib, with the flags held in position completely above the sign face, and with each staff at an angle of 30 to 60 degrees from the vertical centerline of the sign?

Yes	No
X	

13) For particular signs and overlay plaques requiring hook and loop (H&L) strips for temporary overlay attachment, the hook ("coarse") side of the H&L is attached to the sign faces, and the loop ("fuzzy") side of the H&L is attached to the back face of the overlays?

Yes	No
X	

14) All signs to present a finished, professional look to the motorist with no sagging of the sign material?

Yes	No
X	

15) Signs to include anti-kite H&L loops attached to the back faces of the signs for connection around the ribs of the signs (manufacturer shall determine appropriate locations for anti-kite H&L strips)?

Yes	No
X	

16) H&L material to be fastened near the vertical center of one of the horizontal end points on each sign, and to be oriented such that when the sign is rolled up on the vertical rib the H&L material will encircle the sign and hold it in the rolled up storing position?

Yes	No
X	

17) All signs to have a permanent sticker affixed to the non-reflective face with the wording "PROPERTY OF WVDOH" in 1/2" minimum legend size?

Yes	No
X	

18) Rib sizes, rib locations, rib lengths, corner pocket locations, and rotation point locations to be in substantial conformance as shown in the supplemental drawings included within the Contract?

Yes	No
X	

19) Identification to be printed in the margin for convenient indication of the sign message when the sign is rolled up for storage?

Yes	No
X	

PRINT NAME: Scott Wolf

SIGN NAME: 

NAME OF VENDOR: Dicke Tool Company

DATE: 3-22-2024

SUPPLEMENTAL ROLL-UP SIGN ORDERING INFORMATION

The following is a listing of diamond shaped signs for which alternate messages may be displayed using supplemental overlay plaques. All such signs are to be ordered with hook & loop strips under item numbers 31, 32, 33, 34, 50, and 51. In addition, all such signs are to be ordered with the indicated "base" sign message being the permanent sign message. All alternate messages to the "base" sign message are to be accomplished by using the supplemental overlay plaques supplied under item numbers 35, 36, 52, and 53

Fabrication Number	Fab Book Description	Applicable Sizes	"Base" Sign Message *	Additional Notes
W4-7	THRU TRAFFIC MERGE LEFT (RIGHT)	36" and 48"	THRU TRAFFIC MERGE <u>RIGHT</u>	
W5-1	ROAD (LANE) (RAMP) NARROWS	36" and 48"	<u>ROAD</u> NARROWS	
W5-1C	NARROW ROAD (LANE) (LANES)	36" only	NARROW <u>ROAD</u>	
W8-9	LOW (NO) SHOULDER	36" and 48"	<u>LOW</u> SHOULDER	
W9-1	LEFT (RIGHT) LANE ENDS	36" and 48"	<u>RIGHT</u> LANE ENDS	
W20-1	ROAD WORK AHEAD (VARIOUS ALTERNATE MESSAGES)	36" only	ROAD WORK <u>AHEAD</u>	Use Item #34
W20-1	ROAD WORK AHEAD (VARIOUS ALTERNATE MESSAGES)	48"	ROAD WORK <u>1 MILE</u>	Use Item #32 No 8x28 "AHEAD" plaques are to be ordered for use with this sign
W20-2	DETOUR 1000 FT (VARIOUS ALTERNATE MESSAGES)	36" and 48"	DETOUR <u>1000 FT</u>	No 8x28 "AHEAD" plaques are to be ordered for use with this sign in the 48" size
W20-3	ROAD CLOSED 1000 FT (VARIOUS ALTERNATE MESSAGES)	36" and 48"	ROAD CLOSED <u>1000 FT</u>	No 8x28 "AHEAD" plaques are to be ordered for use with this sign in the 48" size
W20-4	ONE LANE ROAD 1000 FT (VARIOUS ALTERNATE MESSAGES)	36" and 48"	ONE LANE ROAD <u>1000 FT</u>	No 8x28 "AHEAD" plaques are to be ordered for use with this sign in the 48" size
W20-5	RIGHT (LEFT) (CENTER) LANE CLOSED 1500 FT (VARIOUS ALTERNATE MESSAGES)	36" and 48"	<u>RIGHT</u> LANE CLOSED <u>1500 FT</u>	No 8x28 "AHEAD" plaques are to be ordered for use with this sign in the 48" size
W20-5A	RIGHT (LEFT) TWO LANES CLOSED 1500 FT (VARIOUS ALTERNATE MESSAGES)	36" and 48"	<u>RIGHT</u> TWO LANES CLOSED <u>1500 FT</u>	No 8x28 "AHEAD" plaques are to be ordered for use with this sign in the 48" size
W20-10	SHOULDER CLOSED 1000 FT (VARIOUS ALTERNATE MESSAGES)	36" and 48"	SHOULDER CLOSED <u>1000 FT</u>	No 8x28 "AHEAD" plaques are to be ordered for use with this sign in the 48" size
W20-11	LANE SHIFT 1000 FT (VARIOUS ALTERNATE MESSAGES)	36" and 48"	LANE SHIFT <u>1000 FT</u>	No 8x28 "AHEAD" plaques are to be ordered for use with this sign in the 48" size
W21-5A	RIGHT (LEFT) SHOULDER CLOSED	36" and 48"	<u>RIGHT</u> SHOULDER CLOSED	
W21-5B	RIGHT (LEFT) SHOULDER CLOSED 1000 FT (VARIOUS ALTERNATE MESSAGES)	36" and 48"	<u>RIGHT</u> SHOULDER CLOSED <u>1000 FT</u>	No 8x28 "AHEAD" plaques are to be ordered for use with this sign in the 48" size
W21-5C	SHOULDER WORK AHEAD (VARIOUS ALTERNATE MESSAGES)	36" only	SHOULDER WORK <u>AHEAD</u>	
W21-5C	SHOULDER WORK AHEAD (VARIOUS ALTERNATE MESSAGES)	48"	SHOULDER WORK <u>500 FT</u>	No 8x28 "AHEAD" plaques are to be ordered for use with this sign
W21-7	UTILITY WORK AHEAD (VARIOUS ALTERNATE MESSAGES)	36" only	UTILITY WORK <u>AHEAD</u>	
W21-7	UTILITY WORK AHEAD (VARIOUS ALTERNATE MESSAGES)	48"	UTILITY WORK <u>1 MILE</u>	No 8x28 "AHEAD" plaques are to be ordered for use with this sign
W22-1	BLASTING ZONE AHEAD (VARIOUS ALTERNATE MESSAGES)	36" only	BLASTING ZONE <u>AHEAD</u>	
W22-1	BLASTING ZONE AHEAD (VARIOUS ALTERNATE MESSAGES)	48"	BLASTING ZONE <u>1500 FT</u>	No 8x28 "AHEAD" plaques are to be ordered for use with this sign

* For each sign shown in this column, the underlined portion(s) of the sign text shall have the "hook" strip portion of hook & loop strips installed above & below the text in accordance with the Contract specifications so that overlay plaques may be applied if needed.

BID SCHEDULE

The following estimated quantities are for bid purposes only. Actual quantities will be determined by needs of the West Virginia Division of Highways and may be increased or decreased:

Item Number	Estimated Quantity	Unit of Measure	Description	Inventory Subcode (DOH USE)	Unit Cost	Total
1	1	Each	EA, 36" R1-1F "STOP" sign	010107	73.01	73.01
2	5	Each	EA, 48" R1-1F "STOP" sign	010108	128.75	643.76
3	1	Each	EA, 36" W3-1MF SYMBOLIC "STOP AHEAD" sign		109.11	109.11
4	5	Each	EA, 48" W3-1MF SYMBOLIC "STOP AHEAD" sign	020309	171.46	857.31
5	1	Each	EA, 36" R1-2F "YIELD" sign		73.01	73.01
6	30	Each	EA, 48" R1-2F "YIELD" sign	010114	128.75	3,862.58
7	1	Each	EA, 36" W3-2MF SYMBOLIC "YIELD AHEAD" sign		109.11	109.11
8	5	Each	EA, 48" W3-2MF SYMBOLIC "YIELD AHEAD" sign		171.46	857.31
9	10	Each	EA., 36" x 60" R2-1MF "WORK ZONE SPEED LIMIT ____" W/ HOOK & LOOP FOR NUMERAL OVERLAY PLAQUES (ORDER NUMERALS UNDER ITEM #10)	010289	163	1,630.05

ORDERING NOTES FOR DOH PERSONNEL:

FL-ORANGE DIAMOND SIGNS BEGINNING WITH TEXT "ROAD WORK" ARE TO BE ORDERED UNDER ITEM NUMBERS 28, 30, 32, OR 34 ONLY. W20-7A AND W21-1A SIGNS ARE TO BE ORDERED UNDER ITEM NUMBERS 28 OR 30 ONLY

SEE ATTACHED COMMISSIONERS ORDERS REGARDING THE PROPER USE OF ITEM # 9. BASED ON THESE COMMISSIONER'S ORDERS, THIS ITEM MAY BE USED ONLY ON CONTROLLED ACCESS FREEWAYS OR EXPRESSWAYS WHEN THE DURATION OF THE OF THE WORK ACTIVITY IS NOT TO EXCEED ONE DAYLIGHT PERIOD.

ALL DIAMOND SHAPED SIGNS WHICH MAY POTENTIALLY BE ALTERED WITH OVERLAY PLAQUES ARE TO BE ORDERED WITH HOOK AND LOOP STRIPS UNDER ITEM NUMBERS 31, 32, 33, AND 34. SEE ATTACHED "SUPPLEMENTAL ROLL-UP SIGN ORDERING INFORMATION" SHEET FOR FURTHER GUIDANCE.

ITEMS 38 THROUGH 53 INCIDENT MANAGEMENT SIGNS ARE ONLY TO BE ORDERED AS DIRECTIONED AND COORDINATED BY THE TRAFFIC ENGINEERING DIVISION CENTRAL OFFICE

Item Number	Estimated Quantity	Unit of Measure	Description	Inventory Subcode (DOH USE)	Unit Cost	Total
10	1	Each	EA., 14" X 17" NUMERAL OVERLAY PLAQUES FOR ITEM NUMBER 9 (SPECIFY QTY OF EACH INDIVIDUAL NUMERAL TO BE SUPPLIED)		19.05	19.05
11	10	Each	EA., 48" X 24" R4-14(L/R)F "ALL TRAFFIC (W/ INTERCHANGEABLE ARROW HEAD)"	010458	107.95	1,079.50
12	1	Each	EA, 24"x30" R4-7BF "KEEP RIGHT" SIGN		70.36	70.36
13	1	Each	EA, 36"X48" R4-7BF "KEEP RIGHT" SIGN		112.61	112.61
14	1	Each	EA., 30"X18" R9-9F "SIDEWALK CLOSED"		62.51	62.51
15	50	Each	EA., 48"X30" R11-2F "ROAD CLOSED" W/ HOOK & LOOP FOR OVERLAY PLAQUES (ORDER "BRIDGE" AND "RAMP" OVERLAYS UNDER ITEM #16)	011110	99.97	4,998.72
16	50	Each	EA., 10" X 39" "BRIDGE" AND "RAMP" OVERLAY PLAQUES FOR ITEM 15 (SPECIFY QTY OF EACH INDIVIDUAL PLAQUE TO BE SUPPLIED)	011112 (BRIDGE) 011113 (RAMP)	29.21	1,460.50
17	10	Each	EA., 60" X 30" R11-3AF "ROAD CLOSED _____ MI AHEAD LOCAL TRAFFIC ONLY" W/ HOOK & LOOP FOR NUMERAL OVERLAY PLAQUES (ORDER NUMERALS UNDER ITEM #18)	011128	155.18	1,551.81
18	40	Each	EA., 5" X 7" NUMERAL OVERLAY PLAQUES FOR ITEM NUMBER 17 (SPECIFY QTY OF EACH INDIVIDUAL NUMERAL TO BE SUPPLIED)		13.58	543.05
19	10	Each	EA., 60"X30" R11-4F "ROAD CLOSED TO THRU TRAFFIC"	011135	151.37	1,513.71
20	1	Each	EA., 48"X36" W22-10F "EXIT _____ " W/ HOOK & LOOP FOR OVERLAYS (ORDER "OPEN" AND "CLOSED" PLAQUES UNDER ITEM #21)	022260	120.23	120.23
21	1	Each	EA., 10" X 40" "OPEN" AND "CLOSED" OVERLAY PLAQUES FOR ITEM 20 (SPECIFY QTY OF EACH INDIVIDUAL PLAQUE TO BE SUPPLIED)	022261 (OPEN) 022262 (CLOSED)	29.21	29.21

ORDERING NOTES FOR DOH PERSONNEL:

FL-ORANGE DIAMOND SIGNS BEGINNING WITH TEXT "ROAD WORK" ARE TO BE ORDERED UNDER ITEM NUMBERS 28, 30, 32, OR 34 ONLY. W20-7A AND W21-1A SIGNS ARE TO BE ORDERED UNDER ITEM NUMBERS 28 OR 30 ONLY

SEE ATTACHED COMMISSIONERS ORDERS REGARDING THE PROPER USE OF ITEM # 9. BASED ON THESE COMMISSIONER'S ORDERS, THIS ITEM MAY BE USED ONLY ON CONTROLLED ACCESS FREEWAYS OR EXPRESSWAYS WHEN THE DURATION OF THE OF THE WORK ACTIVITY IS NOT TO EXCEED ONE DAYLIGHT PERIOD.

ALL DIAMOND SHAPED SIGNS WHICH MAY POTENTIALLY BE ALTERED WITH OVERLAY PLAQUES ARE TO BE ORDERED WITH HOOK AND LOOP STRIPS UNDER ITEM NUMBERS 31, 32, 33, AND 34. SEE ATTACHED "SUPPLEMENTAL ROLL-UP SIGN ORDERING INFORMATION" SHEET FOR FURTHER GUIDANCE.

ITEMS 38 THROUGH 53 INCIDENT MANAGEMENT SIGNS ARE ONLY TO BE ORDERED AS DIRECTED AND COORDINATED BY THE TRAFFIC ENGINEERING DIVISION CENTRAL OFFICE

Item Number	Estimated Quantity	Unit of Measure	Description	Inventory Subcode (DOH USE)	Unit Cost	Total
22	1	Each	EA., 60"X60" W22-11F EXIT GORE SIGN	022269	184.15	184.15
23	1	Each	EA., 30"X24" M4-9F STANDARD DETOUR SIGN W/ HOOK & LOOP AND ARROW OVERLAY PLAQUE		87.63	87.63
24	10	Each	EA., 48"X48" EMERGENCY RESPONSE TRAILER DETOUR SIGN W/ HOOK & LOOP FOR OVERLAY PLAQUES AND ARROW OVERLAY PLAQUE (ORDER ROUTE AND CARDINAL DIRECTION PLAQUES UNDER ITEM NUMBERS 25 & 26)	114848	119.66	1,196.59
25	30	Each	EA., 9" X 28" EMERGENCY RESPONSE TRAILER ROUTE OVERLAY PLAQUE FOR ITEM 24 (SPECIFY EACH INDIVIDUAL ROUTE PLAQUE TO BE SUPPLIED AND QTY OF EACH)	110928	13.58	407.29
26	1	Each	EA., 9" X 7" EMERGENCY RESPONSE TRAILER CARDINAL DIRECTION OVERLAY PLAQUE FOR ITEM 24 (SPECIFY QTY OF EACH "N", "S", "E", AND "W" PLAQUES TO BE SUPPLIED)	110709	13.58	13.58
27	35	Each	Ea., 48" x 48" DIAMOND, FLUORESCENT ORANGE, STANDARD MESSAGE ROLL-UP SIGN (SPECIFY QUANTITY OF EACH FABRICATION NUMBER TO BE SUPPLIED)		115.85	4,054.73
28	570	Each	Ea., 48" x 48" DIAMOND, FLUORESCENT ORANGE, STANDARD MESSAGE ROLL-UP SIGN, W/ PERMANENT ADDITION OF TWO (2) 18" X 18" VINYL FOLDING FLAGS. (SPECIFY QUANTITY OF EACH FABRICATION NUMBER TO BE SUPPLIED)		126.67	72,201.79
29	640	Each	Ea., 36" x 36" DIAMOND, FLUORESCENT ORANGE, STANDARD MESSAGE ROLL-UP SIGN (SPECIFY QUANTITY OF EACH FABRICATION NUMBER TO BE SUPPLIED)		79.17	50,669.95
30	750	Each	Ea., 36" x 36" DIAMOND, FLUORESCENT ORANGE, STANDARD MESSAGE ROLL-UP SIGN, WITH PERMANENT ADDITION OF TWO (2) 18"X18" VINYL FOLDING FLAGS . (SPECIFY QUANTITY OF EACH FABRICATION NUMBER TO BE SUPPLIED)		89.98	67,484.63
31	85	Each	Ea., 48" x 48" DIAMOND, FLUORESCENT ORANGE, STANDARD MESSAGE ROLL-UP SIGN WITH HOOK & LOOP STRIPS FOR OVERLAY ATTACHMENTS (SPECIFY QTY OF EACH FABRICATION NUMBER TO BE SUPPLIED AND PORTION OF TEXT INTENDED TO BE COVERED WITH OVERLAY PLAQUES - ORDER OVERLAY PLAQUES UNDER BID ITEM 35)		119.66	10,171.05

ORDERING NOTES FOR DOH PERSONNEL:

FL-ORANGE DIAMOND SIGNS BEGINNING WITH TEXT "ROAD WORK" ARE TO BE ORDERED UNDER ITEM NUMBERS 28, 30, 32, OR 34 ONLY. W20-7A AND W21-1A SIGNS ARE TO BE ORDERED UNDER ITEM NUMBERS 28 OR 30 ONLY

SEE ATTACHED COMMISSIONERS ORDERS REGARDING THE PROPER USE OF ITEM # 9. BASED ON THESE COMMISSIONER'S ORDERS, THIS ITEM MAY BE USED ONLY ON CONTROLLED ACCESS FREEWAYS OR EXPRESSWAYS WHEN THE DURATION OF THE OF THE WORK ACTIVITY IS NOT TO EXCEED ONE DAYLIGHT PERIOD.

ALL DIAMOND SHAPED SIGNS WHICH MAY POTENTIALLY BE ALTERED WITH OVERLAY PLAQUES ARE TO BE ORDERED WITH HOOK AND LOOP STRIPS UNDER ITEM NUMBERS 31, 32, 33, AND 34. SEE ATTACHED "SUPPLEMENTAL ROLL-UP SIGN ORDERING INFORMATION" SHEET FOR FURTHER GUIDANCE.

ITEMS 38 THROUGH 53 INCIDENT MANAGEMENT SIGNS ARE ONLY TO BE ORDERED AS DIRECTED AND COORDINATED BY THE TRAFFIC ENGINEERING DIVISION CENTRAL OFFICE

Item Number	Estimated Quantity	Unit of Measure	Description	Inventory Subcode (DOH USE)	Unit Cost	Total
32	175	Each	Ea., 48" x 48" DIAMOND, FLUORESCENT ORANGE, STANDARD MESSAGE ROLL-UP SIGN WITH PERMANENT ADDITION OF TWO (2) 18"X18" VINYL FOLDING FLAGS, AND HOOK & LOOP STRIPS FOR OVERLAY ATTACHMENTS (SPECIFY QTY OF EACH FABRICATION NUMBER TO BE SUPPLIED AND PORTION OF TEXT INTENDED TO BE COVERED WITH OVERLAY PLAQUES - ORDER OVERLAY PLAQUES UNDER BID ITEM 35)		130.48	22,833.97
33	1	Each	Ea., 36" x 36" DIAMOND, FLUORESCENT ORANGE, STANDARD MESSAGE ROLL-UP SIGN WITH HOOK & LOOP STRIPS FOR OVERLAY ATTACHMENTS (SPECIFY QTY OF EACH FABRICATION NUMBER TO BE SUPPLIED AND PORTION OF TEXT INTENDED TO BE COVERED WITH OVERLAY PLAQUES - ORDER OVERLAY PLAQUES UNDER BID ITEM 36)		82.98	82.98
34	60	Each	Ea., 36" x 36" DIAMOND, FLUORESCENT ORANGE, STANDARD MESSAGE ROLL-UP SIGN WITH PERMANENT ADDITION OF TWO (2) 18"X18" VINYL FOLDING FLAGS, AND HOOK & LOOP STRIPS FOR OVERLAY ATTACHMENTS (SPECIFY QTY OF EACH FABRICATION NUMBER TO BE SUPPLIED AND PORTION OF TEXT INTENDED TO BE COVERED WITH OVERLAY PLAQUES - ORDER OVERLAY PLAQUES UNDER BID ITEM 36)		93.79	5,627.37
35	310	Each	Ea., 8" X 21" ("LEFT" AND "CENTER" TEXT ONLY) OR 8" x 28" FLUORESCENT ORANGE OVERLAYS WITH H&L STRIPS FOR USE WITH ITEM NUMBERS 33 AND 34. EXAMPLES: LEFT, 500 FT., 1000 FT., 1500 FT., 1/2 MILE, AND 1 MILE (SPECIFY QUANTITY OF EACH PLAQUE TO BE SUPPLIED)		13.53	4,192.91
36	10	Each	Ea., 6" x 21" FLUORESCENT ORANGE OVERLAYS WITH H&L STRIPS FOR USE WITH ITEM NUMBERS 35 AND 36. EXAMPLES: LEFT, 500 FT., 1000 FT., 1500 FT., 1/2 MILE, 1 MILE, and AHEAD (SPECIFY QUANTITY OF EACH PLAQUE TO BE SUPPLIED)		13.53	135.26
37	1	Each	EA, 18"x36" G20-2 "END ROAD WORK" SIGN		68.78	68.78

ORDERING NOTES FOR DOH PERSONNEL:

FL-ORANGE DIAMOND SIGNS BEGINNING WITH TEXT "ROAD WORK" ARE TO BE ORDERED UNDER ITEM NUMBERS 28, 30, 32, OR 34 ONLY. W20-7A AND W21-1A SIGNS ARE TO BE ORDERED UNDER ITEM NUMBERS 28 OR 30 ONLY

SEE ATTACHED COMMISSIONERS ORDERS REGARDING THE PROPER USE OF ITEM # 9. BASED ON THESE COMMISSIONER'S ORDERS, THIS ITEM MAY BE USED ONLY ON CONTROLLED ACCESS FREEWAYS OR EXPRESSWAYS WHEN THE DURATION OF THE OF THE WORK ACTIVITY IS NOT TO EXCEED ONE DAYLIGHT PERIOD.

ALL DIAMOND SHAPED SIGNS WHICH MAY POTENTIALLY BE ALTERED WITH OVERLAY PLAQUES ARE TO BE ORDERED WITH HOOK AND LOOP STRIPS UNDER ITEM NUMBERS 31, 32, 33, AND 34. SEE ATTACHED "SUPPLEMENTAL ROLL-UP SIGN ORDERING INFORMATION" SHEET FOR FURTHER GUIDANCE.

ITEMS 38 THROUGH 53 INCIDENT MANAGEMENT SIGNS ARE ONLY TO BE ORDERED AS DIRECETED AND COORDINATED BY THE TRAFFIC ENGINEERING DIVISION CENTRAL OFFICE

FLUORESCENT PINK SIGN PORTION						
Item Number	Estimated Quantity	Unit of Measure	Description	Inventory Subcode (DOH USE)	Unit Cost	Total
38	1	Each	EA, 36" W3-1MF SYMBOLIC "STOP AHEAD" sign, fluorescent-pink		109.11	109.11
39	1	Each	EA, 48" W3-1MF SYMBOLIC "STOP AHEAD" sign, fluorescent-pink		171.46	171.46
40	1	Each	EA, 36" W3-2MF SYMBOLIC "YIELD AHEAD" sign, fluorescent-pink		109.11	109.11
41	1	Each	EA, 48" W3-2MF SYMBOLIC "YIELD AHEAD" sign, fluorescent-pink		171.46	171.46
42	1	Each	EA., 48"X36" W22-10F "EXIT _____" W/ HOOK & LOOP FOR OVERLAYS, fluorescent-pink (ORDER "OPEN" AND "CLOSED" PLAQUES UNDER ITEM #49)		126.37	126.37
43	1	Each	EA., 10" X 40" "OPEN" AND "CLOSED" OVERLAY PLAQUES FOR ITEM 48, fluorescent-pink (SPECIFY QTY OF EACH INDIVIDUAL PLAQUE TO BE SUPPLIED)		29.21	29.21
44	1	Each	EA., 30"X24" M4-9F STANDARD DETOUR SIGN W/ HOOK & LOOP AND ARROW OVERLAY PLAQUE, fluorescent-pink		91.55	91.55

ORDERING NOTES FOR DOH PERSONNEL:

FL-ORANGE DIAMOND SIGNS BEGINNING WITH TEXT "ROAD WORK" ARE TO BE ORDERED UNDER ITEM NUMBERS 28, 30, 32, OR 34 ONLY. W20-7A AND W21-1A SIGNS ARE TO BE ORDERED UNDER ITEM NUMBERS 28 OR 30 ONLY

SEE ATTACHED COMMISSIONERS ORDERS REGARDING THE PROPER USE OF ITEM # 9. BASED ON THESE COMMISSIONER'S ORDERS, THIS ITEM MAY BE USED ONLY ON CONTROLLED ACCESS FREEWAYS OR EXPRESSWAYS WHEN THE DURATION OF THE OF THE WORK ACTIVITY IS NOT TO EXCEED ONE DAYLIGHT PERIOD.

ALL DIAMOND SHAPED SIGNS WHICH MAY POTENTIALLY BE ALTERED WITH OVERLAY PLAQUES ARE TO BE ORDERED WITH HOOK AND LOOP STRIPS UNDER ITEM NUMBERS 31, 32, 33, AND 34. SEE ATTACHED "SUPPLEMENTAL ROLL-UP SIGN ORDERING INFORMATION" SHEET FOR FURTHER GUIDANCE.

ITEMS 38 THROUGH 53 INCIDENT MANAGEMENT SIGNS ARE ONLY TO BE ORDERED AS DIRECTED AND COORDINATED BY THE TRAFFIC ENGINEERING DIVISION CENTRAL OFFICE

Item Number	Estimated Quantity	Unit of Measure	Description	Inventory Subcode (DOH USE)	Unit Cost	Total
45	1	Each	EA., 48"X48" EMERGENCY RESPONSE TRAILER DETOUR SIGN W/ HOOK & LOOP FOR OVERLAY PLAQUES AND ARROW OVERLAY PLAQUE, fluorescent-pink (ORDER ROUTE AND CARDINAL DIRECTION PLAQUES UNDER ITEM NUMBERS 52 & 53)		96.04	96.04
46	1	Each	EA., 9" X 28" EMERGENCY RESPONSE TRAILER ROUTE OVERLAY PLAQUE FOR ITEM 51, fluorescent-pink (SPECIFY EACH INDIVIDUAL ROUTE PLAQUE TO BE SUPPLIED AND QTY OF EACH)		17.78	17.78
47	1	Each	EA., 9" X 7" EMERGENCY RESPONSE TRAILER CARDINAL DIRECTION OVERLAY PLAQUE FOR ITEM 51, fluorescent-pink (SPECIFY QTY OF EACH "N", "S", "E", AND "W" PLAQUES TO BE SUPPLIED)		17.78	17.78
48	1	Each	Ea., 48" x 48" DIAMOND, FLUORESCENT PINK, STANDARD MESSAGE ROLL-UP SIGN (SPECIFY QUANTITY OF EACH FABRICATION NUMBER TO BE SUPPLIED)		92.23	92.23
49	1	Each	Ea., 36" x 36" DIAMOND, FLUORESCENT PINK, STANDARD MESSAGE ROLL-UP SIGN (SPECIFY QUANTITY OF EACH FABRICATION NUMBER TO BE SUPPLIED)		64.34	64.34
50	1	Each	Ea., 48" x 48" DIAMOND, FLUORESCENT PINK, STANDARD MESSAGE ROLL-UP SIGN WITH HOOK & LOOP STRIPS FOR OVERLAY ATTACHMENTS (SPECIFY QTY OF EACH FABRICATION NUMBER TO BE SUPPLIED AND PORTION OF TEXT INTENDED TO BE COVERED WITH OVERLAY PLAQUES - ORDER OVERLAY PLAQUES UNDER BID ITEM 52)		96.04	96.04
51	1	Each	Ea., 36" x 36" DIAMOND, FLUORESCENT PINK, STANDARD MESSAGE ROLL-UP SIGN WITH HOOK & LOOP STRIPS FOR OVERLAY ATTACHMENTS (SPECIFY QTY OF EACH FABRICATION NUMBER TO BE SUPPLIED AND PORTION OF TEXT INTENDED TO BE COVERED WITH OVERLAY PLAQUES - ORDER OVERLAY PLAQUES UNDER BID ITEM 53)		68.15	68.15
52	1	Each	Ea., 8" X 21" ("LEFT" AND "CENTER" TEXT ONLY) OR 8" x 28" FLUORESCENT PINK OVERLAYS WITH H&L STRIPS FOR USE WITH ITEM NUMBER 50. EXAMPLES: LEFT, 500 FT., 1000 FT., 1500 FT., 1/2 MILE, AND 1 MILE (SPECIFY QUANTITY OF EACH PLAQUE TO BE SUPPLIED)		17.78	17.78
53	1	Each	Ea., 6" x 21" FLUORESCENT PINK OVERLAYS WITH H&L STRIPS FOR USE WITH ITEM NUMBER 53. EXAMPLES: LEFT, 500 FT., 1000 FT., 1500 FT., 1/2 MILE, 1 MILE, and AHEAD (SPECIFY QUANTITY OF EACH PLAQUE TO BE SUPPLIED)		17.78	17.78

ORDERING NOTES FOR DOH PERSONNEL:

FL-ORANGE DIAMOND SIGNS BEGINNING WITH TEXT "ROAD WORK" ARE TO BE ORDERED UNDER ITEM NUMBERS 28, 30, 32, OR 34 ONLY. W20-7A AND W21-1A SIGNS ARE TO BE ORDERED UNDER ITEM NUMBERS 28 OR 30 ONLY

SEE ATTACHED COMMISSIONERS ORDERS REGARDING THE PROPER USE OF ITEM # 9. BASED ON THESE COMMISSIONER'S ORDERS, THIS ITEM MAY BE USED ONLY ON CONTROLLED ACCESS FREEWAYS OR EXPRESSWAYS WHEN THE DURATION OF THE OF THE WORK ACTIVITY IS NOT TO EXCEED ONE DAYLIGHT PERIOD.

ALL DIAMOND SHAPED SIGNS WHICH MAY POTENTIALLY BE ALTERED WITH OVERLAY PLAQUES ARE TO BE ORDERED WITH HOOK AND LOOP STRIPS UNDER ITEM NUMBERS 31, 32, 33, AND 34. SEE ATTACHED "SUPPLEMENTAL ROLL-UP SIGN ORDERING INFORMATION" SHEET FOR FURTHER GUIDANCE.

ITEMS 38 THROUGH 53 INCIDENT MANAGEMENT SIGNS ARE ONLY TO BE ORDERED AS DIRECTED AND COORDINATED BY THE TRAFFIC ENGINEERING DIVISION CENTRAL OFFICE



WOMEN'S BUSINESS ENTERPRISE
NATIONAL COUNCIL

JOIN FORCES. SUCCEED TOGETHER.

hereby grants

National Women's Business Enterprise Certification

to

Dicke Tool Company DBA DICKE Safety Products

who has successfully met WBENC's standards as a Women's Business Enterprise (WBE).
This certification affirms the business is woman-owned, operated and controlled and is valid through the date herein.

WBENC National WBE Certification was processed and validated by Women's Business Development Center - Midwest, a WBENC Regional Partner Organization.

Certification Granted: June 30, 2010

Expiration Date: June 30, 2024

WBENC National Certification Number: 2005115928

Authorized by Emilia DiMenco, President &
CEO Women's Business Development Center -
Midwest



NAICS: 332312, 238990, 339950, 339999
UNSPSC: 55121710





DICKE SAFETY PRODUCTS

1201 Warren Avenue • Downers Grove, IL 60515 • Ph: 877.891.0050 • Fax: 630.969.3973

Date: March 22, 2024

VENDOR NAME: Dicke Tool Company
1201 Warren Ave.
Downers Grove, IL 60515

BUYER: John Estep
SOLICITATION NO.: CRFQ 0803 DOT2400000081
BID OPENING DATE: March 26, 2024
BID OPENING TIME: 1:30 PM
FAX NUMBER: 304-558-3970

To Whom I May Concern,

The solicitation, under Item 11 titled “EXPECTATIONS AND CLAIRIFICATIONS” in the “Instructions to Vendors Submitting Bids” asks for clarifications regarding the bid. Please note that Line Items 38-53 call for “fluorescent-pink” reflective sheeting. This sheeting is not made in Orafol Marathon material but only made in Orafol Superbright material so we have bid the Superbright “fluorescent-pink” for these line items. We do specify and note both of these materials on the “Product Compliance Checklist Form” at the end of the “Exhibits C” document.

Sincerely,

Scott Wolf

Dicke Tool Company (dba Dicke Safety Products)
1201 Warren Ave.
Downers Grove, IL 60515