



Department of Administration
 Purchasing Division
 2019 Washington Street East
 Post Office Box 50130
 Charleston, WV 25305-0130

State of West Virginia
 Centralized Request for Quote
 Construction

RECEIVED

2021 AUG 31 AM 11:45

WV PURCHASING
 DIVISION

Proc Folder: 899930
 Doc Description: ROOFING SYSTEM
 Proc Type: Central Purchase Order

Date Issued	Solicitation Closes	Solicitation No	Version
2021-07-20	2021-08-17 13:30	CRFQ 0803 DOT2200000020	1

BID RECEIVING LOCATION

BID CLERK
 DEPARTMENT OF ADMINISTRATION
 PURCHASING DIVISION
 2019 WASHINGTON ST E
 CHARLESTON WV 25305
 US

VENDOR

Vendor Customer Code:
 Vendor Name :
 Address : **R & T ENTERPRISES, INC.**
 P.O. BOX 727
 Street : **BRIDGEPORT, WV 26330**
 304-623-4827
 City :
 State : Country : Zip :
 Principal Contact : *Nathaniel G. Rohy*
 Vendor Contact Phone: *(304) 623-4827* Extension:

FOR INFORMATION CONTACT THE BUYER

John W Estep
 304-558-2566
 john.w.estep@wv.gov

Vendor Signature X  FEIN# *55-057-4291* DATE *8-13-21*

All offers subject to all terms and conditions contained in this solicitation

ADDITIONAL INFORMATION

REQUEST FOR QUOTATION :

The West Virginia Purchasing Division is soliciting bids on behalf of West Virginia Division of Highways (WVDOH) to establish a contract for the following: Installation of a roof system for the Sugar Grove Salt Shed in Pendleton County, West Virginia. The roof system would be designed and installed to consist of a single span truss arch, fabric covered, steel framed building roof system, to clear span the 42 ft. OD x 32 ft. OD structure, as per the attached Project Plans and documents. Per the bid requirements, Specifications, Terms and Conditions attached to this Solicitation.

INVOICE TO**SHIP TO**

DIVISION OF HIGHWAYS
DISTRICT EIGHT - ALL
LOCATIONS
PO BOX 1516
ELKINS WV
US

WV DIVISION OF HIGHWAYS
SUGAR GROVE SUBSTATION
9315 SUGAR GROVE RD
SUGAR GROVE WV
US

Line	Comm Ln Desc	Qty	Unit Issue	Unit Price	Total Price
1	Roofing System	1.00000	EA	# 61,649.28	

Comm Code	Manufacturer	Specification	Model #
25174100	Brestspan		Atlas

Extended Description:

32' x 42' Roofing System for the Sugar Grove Salt Shed

SCHEDULE OF EVENTS

<u>Line</u>	<u>Event</u>	<u>Event Date</u>
1	Pre-bid Meeting 1:00pm - Sugar Grove Salt Shed	2021-07-27
2	Tech Questions due by: 10:00am	2021-08-03

	Document Phase	Document Description	Page
DOT2200000020	Final	ROOFING SYSTEM	3

ADDITIONAL TERMS AND CONDITIONS

See attached document(s) for additional Terms and Conditions



Department of Administration
 Purchasing Division
 2019 Washington Street East
 Post Office Box 50130
 Charleston, WV 25305-0130

State of West Virginia
 Centralized Request for Quote
 Construction

Proc Folder: 899930 Doc Description: ADDENDUM NO_1 ROOFING SYSTEM Proc Type: Central Purchase Order			Reason for Modification: Addendum No_1 attach pre bid sign-in sheets
Date Issued	Solicitation Closes	Solicitation No	Version
2021-07-29	2021-08-17 13:30	CRFQ 0803 DOT2200000020	2

BID RECEIVING LOCATION

BID CLERK
 DEPARTMENT OF ADMINISTRATION
 PURCHASING DIVISION
 2019 WASHINGTON ST E
 CHARLESTON WV 25305
 US

VENDOR

Vendor Customer Code:

Vendor Name :

Address : R & T ENTERPRISES, INC.
 P.O. BOX 727
Street : BRIDGEPORT, WV 26330
 304-623-4827

City :

State : **Country :** **Zip :**

Principal Contact : Nathaniel G. Rohrig

Vendor Contact Phone: 304-623-4827 **Extension:**

FOR INFORMATION CONTACT THE BUYER
 John W Estep
 304-558-2566
 john.w.estep@wv.gov

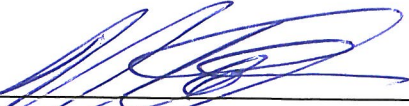
Vendor Signature X  **FEIN#** 55-057-4291 **DATE** 8-13-21

All offers subject to all terms and conditions contained in this solicitation

ADDITIONAL INFORMATION

ADDENDUM NO_1

Addendum No_1 issued to publish and distribute the attached information to the Vendor Community

REQUEST FOR QUOTATION :

The West Virginia Purchasing Division is soliciting bids on behalf of West Virginia Division of Highways (WVDOH) to establish a contract for the following: Installation of a roof system for the Sugar Grove Salt Shed in Pendleton County, West Virginia. The roof system would be designed and installed to consist of a single span truss arch, fabric covered, steel framed building roof system, to clear span the 42 ft. OD x 32 ft. OD structure, as per the attached Project Plans and documents. Per the bid requirements, Specifications, Terms and Conditions attached to this Solicitation.

INVOICE TO**SHIP TO**

DIVISION OF HIGHWAYS
 DISTRICT EIGHT - ALL
 LOCATIONS
 PO BOX 1516
 ELKINS WV
 US

WV DIVISION OF HIGHWAYS
 SUGAR GROVE SUBSTATION
 9315 SUGAR GROVE RD
 SUGAR GROVE WV
 US

Line	Comm Ln Desc	Qty	Unit Issue	Unit Price	Total Price
1	Roofing System	1.00000	EA	\$ 61,649.28	

Comm Code	Manufacturer	Specification	Model #
25174100	Brite span		Atlas

Extended Description:

32' x 42' Roofing System for the Sugar Grove Salt Shed

SCHEDULE OF EVENTS

Line	Event	Event Date
1	Pre-bid Meeting 1:00pm - Sugar Grove Salt Shed	2021-07-27
2	Tech Questions due by: 10:00am	2021-08-03

	Document Phase	Document Description	Page
DOT2200000020	Final	ADDENDUM NO_1 ROOFING SYSTEM	3

ADDITIONAL TERMS AND CONDITIONS

See attached document(s) for additional Terms and Conditions



Department of Administration
 Purchasing Division
 2019 Washington Street East
 Post Office Box 50130
 Charleston, WV 25305-0130

State of West Virginia
 Centralized Request for Quote
 Construction

Proc Folder: 899930			Reason for Modification: Addendum No_1 attach pre bid sign-in sheets
Doc Description: ADDENDUM NO_1 ROOFING SYSTEM			
Proc Type: Central Purchase Order			
Date Issued	Solicitation Closes	Solicitation No	Version
2021-07-29	2021-08-17 13:30	CRFQ 0803 DOT2200000020	2

BID RECEIVING LOCATION

BID CLERK
 DEPARTMENT OF ADMINISTRATION
 PURCHASING DIVISION
 2019 WASHINGTON ST E
 CHARLESTON WV 25305
 US

VENDOR

Vendor Customer Code:

Vendor Name : R & T ENTERPRISES, INC.
 P.O. BOX 727
Address : BRIDGEPORT, WV 26330
Street : 304-623-4827

City :

State : **Country :** **Zip :**

Principal Contact : Nathaniel G. Rohrig

Vendor Contact Phone: 304-623-4827 **Extension:**

FOR INFORMATION CONTACT THE BUYER
 John W Estep
 304-558-2566
 john.w.estep@wv.gov

Vendor Signature X  **FEIN#** 55-057-4291 **DATE** 8-13-21

All offers subject to all terms and conditions contained in this solicitation

ADDITIONAL INFORMATION

ADDENDUM NO_1

Addendum No_1 issued to publish and distribute the attached information to the Vendor Community

REQUEST FOR QUOTATION :

The West Virginia Purchasing Division is soliciting bids on behalf of West Virginia Division of Highways (WVDOH) to establish a contract for the following: Installation of a roof system for the Sugar Grove Salt Shed in Pendleton County, West Virginia. The roof system would be designed and installed to consist of a single span truss arch, fabric covered, steel framed building roof system, to clear span the 42 ft. OD x 32 ft. OD structure, as per the attached Project Plans and documents. Per the bid requirements, Specifications, Terms and Conditions attached to this Solicitation.

INVOICE TO		SHIP TO	
DIVISION OF HIGHWAYS DISTRICT EIGHT - ALL LOCATIONS PO BOX 1516 ELKINS WV US		WV DIVISION OF HIGHWAYS SUGAR GROVE SUBSTATION 9315 SUGAR GROVE RD SUGAR GROVE WV US	

Line	Comm Ln Desc	Qty	Unit Issue	Unit Price	Total Price
1	Roofing System	1.00000	EA		61,649.28

Comm Code	Manufacturer	Specification	Model #
25174100	Brickspan		Atlas

Extended Description:

32' x 42' Roofing System for the Sugar Grove Salt Shed

SCHEDULE OF EVENTS

<u>Line</u>	<u>Event</u>	<u>Event Date</u>
1	Pre-bid Meeting 1:00pm - Sugar Grove Salt Shed	2021-07-27
2	Tech Questions due by: 10:00am	2021-08-03

SOLICITATION NUMBER: CRFQ DOT2200000020

Addendum Number: 1

The purpose of this addendum is to modify the solicitation identified as CRFQ DOT2200000020 ("Solicitation") to reflect the change(s) identified and described below.

Applicable Addendum Category:

- Modify bid opening date and time
- Modify specifications of product or service being sought
- Attachment of vendor questions and responses
- Attachment of pre-bid sign-in sheet
- Correction of error
- Other

Additional Documentation:

To attach pre bid sign-in sheets

Bid Opening remains 08/17/21 at 1:30pm

Terms and Conditions:

1. All provisions of the Solicitation and other addenda not modified herein shall remain in full force and effect.
2. Vendor should acknowledge receipt of all addenda issued for this Solicitation by completing an Addendum Acknowledgment, a copy of which is included herewith. Failure to acknowledge addenda may result in bid disqualification. The addendum acknowledgement should be submitted with the bid to expedite document processing.

Pre-Bid Sign-In Sheet

Solicitation Number: CRFQ DOT 2200000020

Date of Pre-Bid Meeting: July 27, 2021

Location of Prebid Meeting: Sugar Grove Substation

Please Note:

Vendors must sign-in on this sheet to verify attendance at the Pre-Bid meeting.
 Failure to legibly sign in may be grounds for declaring a vendor ineligible to bid.
 For further verification, please also provide a business card if possible.

Firm Represented:*	Rep Name (Printed):	Firm Address:	Telephone #:	Fax #:	Email:
WVDOH Procurement	Kristy James	1900 Kanawha Blvd E. Bldg 5 Rm 260	304-414- 7104		Kristy.e.james@ wv.gov
RFT Enterprises Inc	Nate Rohrig	P.O. Box 727 Bridgeport, WV 26330	304-691- 6450	304-622- 5546	Nrohrig@aol. com
WV DOH Dist. 8	MATT CANNON	1101 N. RANDOLPH ELKINS, WV	304-642 0449		MATTHEW.S.CANNON @WV.GOV
WVDOH DB	JEREMIAH KNAVENSHUE	1101 N RANDOLPH ELKINS, WV	304-642-0451		JEREMIAH.K. KNAVENSHUE@WV.GOV

***One Vendor Per Representative - No one individual is permitted to represent more than one vendor at the pre-bid meeting. Any individual that does attempt to represent two or more vendors will be required to select one vendor to which the individual's attendance will be attributed. The vendors not selected will be deemed to have not attended the pre-bid meeting unless another individual attended on their behalf.**

ADDENDUM ACKNOWLEDGEMENT FORM
SOLICITATION NO.: CRFQ DOT2200000020

Instructions: Please acknowledge receipt of all addenda issued with this solicitation by completing this addendum acknowledgment form. Check the box next to each addendum received and sign below. Failure to acknowledge addenda may result in bid disqualification.

Acknowledgment: I hereby acknowledge receipt of the following addenda and have made the necessary revisions to my proposal, plans and/or specification, etc.

Addendum Numbers Received:

(Check the box next to each addendum received)

- | | |
|--|--|
| <input checked="" type="checkbox"/> Addendum No. 1 | <input type="checkbox"/> Addendum No. 6 |
| <input type="checkbox"/> Addendum No. 2 | <input type="checkbox"/> Addendum No. 7 |
| <input type="checkbox"/> Addendum No. 3 | <input type="checkbox"/> Addendum No. 8 |
| <input type="checkbox"/> Addendum No. 4 | <input type="checkbox"/> Addendum No. 9 |
| <input type="checkbox"/> Addendum No. 5 | <input type="checkbox"/> Addendum No. 10 |

I understand that failure to confirm the receipt of addenda may be cause for rejection of this bid. I further understand that that any verbal representation made or assumed to be made during any oral discussion held between Vendor's representatives and any state personnel is not binding. Only the information issued in writing and added to the specifications by an official addendum is binding.

R+T Enterprises, Inc.
Company

Authorized Signature
8-13-21
Date

NOTE: This addendum acknowledgment should be submitted with the bid to expedite document processing.



Department of Administration
 Purchasing Division
 2019 Washington Street East
 Post Office Box 50130
 Charleston, WV 25305-0130

State of West Virginia
 Centralized Request for Quote
 Construction

Proc Folder: 899930			Reason for Modification: ADDENDUM NO_2 To Move Bid Date to 08/31/2021
Doc Description: ADDENDUM NO_2 ROOFING SYSTEM			
Proc Type: Central Purchase Order			
Date Issued	Solicitation Closes	Solicitation No	Version
2021-08-12	2021-08-31 13:30	CRFQ 0803 DOT2200000020	3

BID RECEIVING LOCATION

BID CLERK
 DEPARTMENT OF ADMINISTRATION
 PURCHASING DIVISION
 2019 WASHINGTON ST E
 CHARLESTON WV 25305
 US

VENDOR

Vendor Customer Code:

Vendor Name : R & T ENTERPRISES, INC.

Address : P.O. BOX 727
 BRIDGEPORT, WV 26330

Street : 304-623-4827

City :

State : Country : Zip :

Principal Contact : Nathaniel G. Rohay

Vendor Contact Phone: 304 623 - 4827 Extension:

FOR INFORMATION CONTACT THE BUYER

John W Estep
 304-558-2566
 john.w.estep@wv.gov

Vendor Signature X  FEIN# 55.057-4291 DATE 8-30-21

All offers subject to all terms and conditions contained in this solicitation

ADDITIONAL INFORMATION

ADDENDUM NO_2

Addendum No_2 issued to publish and distribute the attached information to the Vendor Community

REQUEST FOR QUOTATION :

The West Virginia Purchasing Division is soliciting bids on behalf of West Virginia Division of Highways (WVDOH) to establish a contract for the following: Installation of a roof system for the Sugar Grove Salt Shed in Pendleton County, West Virginia. The roof system would be designed and installed to consist of a single span truss arch, fabric covered, steel framed building roof system, to clear span the 42 ft. OD x 32 ft. OD structure, as per the attached Project Plans and documents. Per the bid requirements, Specifications, Terms and Conditions attached to this Solicitation.

INVOICE TO**SHIP TO**

DIVISION OF HIGHWAYS
DISTRICT EIGHT - ALL
LOCATIONS
PO BOX 1516
ELKINS WV
US

WV DIVISION OF HIGHWAYS
SUGAR GROVE SUBSTATION
9315 SUGAR GROVE RD
SUGAR GROVE WV
US

Line	Comm Ln Desc	Qty	Unit Issue	Unit Price	Total Price
1	Roofing System	1.00000	EA		\$ 61,649.28

Comm Code	Manufacturer	Specification	Model #
25174100	Britespan		Atlas

Extended Description:

32' x 42' Roofing System for the Sugar Grove Salt Shed

SCHEDULE OF EVENTS

Line	Event	Event Date
1	Pre-bid Meeting 1:00pm - Sugar Grove Salt Shed	2021-07-27
2	Tech Questions due by: 10:00am	2021-08-03

	Document Phase	Document Description	Page 3
DOT2200000020	Final	ADDENDUM NO_2 ROOFING SYSTEM	

ADDITIONAL TERMS AND CONDITIONS

See attached document(s) for additional Terms and Conditions



Department of Administration
 Purchasing Division
 2019 Washington Street East
 Post Office Box 50130
 Charleston, WV 25305-0130

State of West Virginia
 Centralized Request for Quote
 Construction

Proc Folder: 899930			Reason for Modification: ADDENDUM NO_2 To Move Bid Date to 08/31/2021
Doc Description: ADDENDUM NO_2 ROOFING SYSTEM			
Proc Type: Central Purchase Order			
Date Issued	Solicitation Closes	Solicitation No	Version
2021-08-12	2021-08-31 13:30	CRFQ 0803 DOT2200000020	3

BID RECEIVING LOCATION

BID CLERK
 DEPARTMENT OF ADMINISTRATION
 PURCHASING DIVISION
 2019 WASHINGTON ST E
 CHARLESTON WV 25305
 US

VENDOR

Vendor Customer Code:

Vendor Name : R & T ENTERPRISES, INC.

Address : P.O. BOX 727
 BRIDGEPORT, WV 26330

Street : 304-623-4827

City :



State : Country : Zip :

Principal Contact : Nathaniel G. Rohrig

Vendor Contact Phone: 304-623-4827 Extension:

FOR INFORMATION CONTACT THE BUYER

John W Estep
 304-558-2566
 john.w.estep@wv.gov

Vendor Signature X  FEIN# 55-057-4291 DATE 

All offers subject to all terms and conditions contained in this solicitation

ADDITIONAL INFORMATION

ADDENDUM NO_2

Addendum No_2 issued to publish and distribute the attached information to the Vendor Community

REQUEST FOR QUOTATION :

The West Virginia Purchasing Division is soliciting bids on behalf of West Virginia Division of Highways (WVDOH) to establish a contract for the following: Installation of a roof system for the Sugar Grove Salt Shed in Pendleton County, West Virginia. The roof system would be designed and installed to consist of a single span truss arch, fabric covered, steel framed building roof system, to clear span the 42 ft. OD x 32 ft. OD structure, as per the attached Project Plans and documents. Per the bid requirements, Specifications, Terms and Conditions attached to this Solicitation.

INVOICE TO**SHIP TO**

DIVISION OF HIGHWAYS

DISTRICT EIGHT - ALL
LOCATIONS

PO BOX 1516

ELKINS

WV

US

WV DIVISION OF HIGHWAYS

SUGAR GROVE SUBSTATION

9315 SUGAR GROVE RD

SUGAR GROVE

WV

US

Line	Comm Ln Desc	Qty	Unit Issue	Unit Price	Total Price
1	Roofing System	1.00000	EA	\$ 61,649.28	

Comm Code**Manufacturer****Specification****Model #**

25174100

Britespan

Atlas

Extended Description:

32' x 42' Roofing System for the Sugar Grove Salt Shed

SCHEDULE OF EVENTS

<u>Line</u>	<u>Event</u>	<u>Event Date</u>
1	Pre-bid Meeting 1:00pm - Sugar Grove Salt Shed	2021-07-27
2	Tech Questions due by: 10:00am	2021-08-03

SOLICITATION NUMBER: CRFQ DOT2200000020

Addendum Number: 2

The purpose of this addendum is to modify the solicitation identified as CRFQ DOT2200000020 ("Solicitation") to reflect the change(s) identified and described below.

Applicable Addendum Category:

- Modify bid opening date and time
- Modify specifications of product or service being sought
- Attachment of vendor questions and responses
- Attachment of pre-bid sign-in sheet
- Correction of error
- Other

Additional Documentation:

Bid Opening moves to 08/31/21 at 1:30pm

Terms and Conditions:

1. All provisions of the Solicitation and other addenda not modified herein shall remain in full force and effect.
2. Vendor should acknowledge receipt of all addenda issued for this Solicitation by completing an Addendum Acknowledgment, a copy of which is included herewith. Failure to acknowledge addenda may result in bid disqualification. The addendum acknowledgement should be submitted with the bid to expedite document processing.

ADDENDUM ACKNOWLEDGEMENT FORM
SOLICITATION NO.: CRFQ DOT220000020

Instructions: Please acknowledge receipt of all addenda issued with this solicitation by completing this addendum acknowledgment form. Check the box next to each addendum received and sign below. Failure to acknowledge addenda may result in bid disqualification.

Acknowledgment: I hereby acknowledge receipt of the following addenda and have made the necessary revisions to my proposal, plans and/or specification, etc.

Addendum Numbers Received:

(Check the box next to each addendum received)

- | | |
|--|--|
| <input type="checkbox"/> Addendum No. 1 | <input type="checkbox"/> Addendum No. 6 |
| <input checked="" type="checkbox"/> Addendum No. 2 | <input type="checkbox"/> Addendum No. 7 |
| <input type="checkbox"/> Addendum No. 3 | <input type="checkbox"/> Addendum No. 8 |
| <input type="checkbox"/> Addendum No. 4 | <input type="checkbox"/> Addendum No. 9 |
| <input type="checkbox"/> Addendum No. 5 | <input type="checkbox"/> Addendum No. 10 |

I understand that failure to confirm the receipt of addenda may be cause for rejection of this bid. I further understand that that any verbal representation made or assumed to be made during any oral discussion held between Vendor's representatives and any state personnel is not binding. Only the information issued in writing and added to the specifications by an official addendum is binding.

R&T Enterprises, Inc.
Company

Authorized Signature
8-30-21
Date

NOTE: This addendum acknowledgement should be submitted with the bid to expedite document processing.



Department of Administration
 Purchasing Division
 2019 Washington Street East
 Post Office Box 50130
 Charleston, WV 25305-0130

State of West Virginia
 Centralized Request for Quote
 Construction

Proc Folder: 899930			Reason for Modification: ADDENDUM NO_3 Vendor Questions and Responses
Doc Description: ADDENDUM NO_3 ROOFING SYSTEM			
Proc Type: Central Purchase Order			
Date Issued	Solicitation Closes	Solicitation No	Version
2021-08-12	2021-08-31 13:30	CRFQ 0803 DOT2200000020	4

BID RECEIVING LOCATION

BID CLERK
 DEPARTMENT OF ADMINISTRATION
 PURCHASING DIVISION
 2019 WASHINGTON ST E
 CHARLESTON WV 25305
 US

VENDOR

Vendor Customer Code:

Vendor Name : **R & T ENTERPRISES, INC.**

Address : P.O. BOX 727
 BRIDGEPORT, WV 26330

Street : 304-623-4827

City :

State : Country : Zip :

Principal Contact : *Nathaniel G. Rohrig*

Vendor Contact Phone: *304-623-4827* Extension:

FOR INFORMATION CONTACT THE BUYER
 John W Estep
 304-558-2566
 john.w.estep@wv.gov

Vendor Signature X  FEIN# *55-057-4291* DATE *8-30-21*

All offers subject to all terms and conditions contained in this solicitation

ADDITIONAL INFORMATION

ADDENDUM NO_3

Addendum No_3 issued to publish and distribute the attached information to the Vendor Community

REQUEST FOR QUOTATION :

The West Virginia Purchasing Division is soliciting bids on behalf of West Virginia Division of Highways (WVDOH) to establish a contract for the following: Installation of a roof system for the Sugar Grove Salt Shed in Pendleton County, West Virginia. The roof system would be designed and installed to consist of a single span truss arch, fabric covered, steel framed building roof system, to clear span the 42 ft. OD x 32 ft. OD structure, as per the attached Project Plans and documents. Per the bid requirements, Specifications, Terms and Conditions attached to this Solicitation.

INVOICE TO		SHIP TO	
DIVISION OF HIGHWAYS DISTRICT EIGHT - ALL LOCATIONS PO BOX 1516 ELKINS WV US		WV DIVISION OF HIGHWAYS SUGAR GROVE SUBSTATION 9315 SUGAR GROVE RD SUGAR GROVE WV US	

Line	Comm Ln Desc	Qty	Unit Issue	Unit Price	Total Price
1	Roofing System	1.00000	EA		\$ 61,649.28

Comm Code	Manufacturer	Specification	Model #
25174100	<i>Brute span</i>		<i>Atlas</i>

Extended Description:

32' x 42' Roofing System for the Sugar Grove Salt Shed

SCHEDULE OF EVENTS

<u>Line</u>	<u>Event</u>	<u>Event Date</u>
1	Pre-bid Meeting 1:00pm - Sugar Grove Salt Shed	2021-07-27
2	Tech Questions due by: 10:00am	2021-08-03

SOLICITATION NUMBER: CRFQ DOT2200000020

Addendum Number: 3

The purpose of this addendum is to modify the solicitation identified as CRFQ DOT2200000020 ("Solicitation") to reflect the change(s) identified and described below.

Applicable Addendum Category:

- Modify bid opening date and time
- Modify specifications of product or service being sought
- Attachment of vendor questions and responses
- Attachment of pre-bid sign-in sheet
- Correction of error
- Other

Additional Documentation:

Bid Opening remains 08/31/2021 at 1:30pm

Terms and Conditions:

1. All provisions of the Solicitation and other addenda not modified herein shall remain in full force and effect.
2. Vendor should acknowledge receipt of all addenda issued for this Solicitation by completing an Addendum Acknowledgment, a copy of which is included herewith. Failure to acknowledge addenda may result in bid disqualification. The addendum acknowledgement should be submitted with the bid to expedite document processing.

CRFQ DOT2200000020 ADDENDUM NO. 3

Questions:

Q1: Can a fabric roll-up door be used as an alternative?

A1: A Fabric roll-up door will be accepted

Q2: Can a 220-fabric termination be used instead of a 320 termination? (See attached)

A2: Per the attachment, a 220-fabric termination will be accepted if all metallic materials are galvanized in accordance with the contract documents at III. Steel Frame Requirements, Section E

Q3: Who is responsible for the 36" Fan?

A3: Per the contract documents at III. Steel Frame Requirements, Section K: "The 36"x36" exhaust Fan will be supplies and installed and tested in place by the contractor and it will be suitable for use in the corrosive salt shed environment and will be incidental to the Roof System Line-Item no.1 bid Price. WYDOH will complete the electrical connections necessary for the permanent Exhaust Fan Operation.

Other Information:

1. The bid opening remains on 08/31/2021 at 1:30 pm.

ADDENDUM ACKNOWLEDGEMENT FORM
SOLICITATION NO.: CRFQ DOT2200000030

Instructions: Please acknowledge receipt of all addenda issued with this solicitation by completing this addendum acknowledgment form. Check the box next to each addendum received and sign below. Failure to acknowledge addenda may result in bid disqualification.

Acknowledgment: I hereby acknowledge receipt of the following addenda and have made the necessary revisions to my proposal, plans and/or specification, etc.

Addendum Numbers Received:

(Check the box next to each addendum received)

- | | |
|--|--|
| <input type="checkbox"/> Addendum No. 1 | <input type="checkbox"/> Addendum No. 6 |
| <input type="checkbox"/> Addendum No. 2 | <input type="checkbox"/> Addendum No. 7 |
| <input checked="" type="checkbox"/> Addendum No. 3 | <input type="checkbox"/> Addendum No. 8 |
| <input type="checkbox"/> Addendum No. 4 | <input type="checkbox"/> Addendum No. 9 |
| <input type="checkbox"/> Addendum No. 5 | <input type="checkbox"/> Addendum No. 10 |

I understand that failure to confirm the receipt of addenda may be cause for rejection of this bid. I further understand that that any verbal representation made or assumed to be made during any oral discussion held between Vendor's representatives and any state personnel is not binding. Only the information issued in writing and added to the specifications by an official addendum is binding.

RAT Enterprises, Inc.
Company

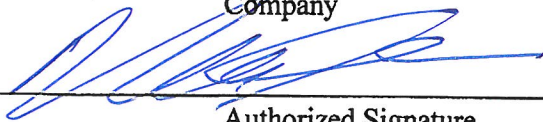
Authorized Signature

8-30-21
Date

NOTE: This addendum acknowledgement should be submitted with the bid to expedite document processing.



Department of Administration
 Purchasing Division
 2019 Washington Street East
 Post Office Box 50130
 Charleston, WV 25305-0130

State of West Virginia
 Centralized Request for Quote
 Construction

Proc Folder: 899930		Reason for Modification:	
Doc Description: ADDENDUM NO_3 ROOFING SYSTEM		ADDENDUM NO_3 Vendor Questions and Responses	
Proc Type: Central Purchase Order			
Date Issued	Solicitation Closes	Solicitation No	Version
2021-08-16	2021-08-31 13:30	CRFQ 0803 DOT2200000020	4

BID RECEIVING LOCATION

BID CLERK
 DEPARTMENT OF ADMINISTRATION
 PURCHASING DIVISION
 2019 WASHINGTON ST E
 CHARLESTON WV 25305
 US

VENDOR

Vendor Customer Code:

Vendor Name : **R & T ENTERPRISES, INC.**

Address : P.O. BOX 727
 BRIDGEPORT, WV 26330

Street : 304-623-4827

City :

State : Country : Zip :

Principal Contact : *Nathaniel G. Foley*

Vendor Contact Phone: *304-623-4827* Extension:

FOR INFORMATION CONTACT THE BUYER

John W Estep
 304-558-2566
 john.w.estep@wv.gov

Vendor Signature X  FEIN# *55-057-4291* DATE *8-30-21*

All offers subject to all terms and conditions contained in this solicitation

ADDITIONAL INFORMATION

ADDENDUM NO_3

Addendum No_3 issued to publish and distribute the attached information to the Vendor Community

REQUEST FOR QUOTATION :

The West Virginia Purchasing Division is soliciting bids on behalf of West Virginia Division of Highways (WVDOH) to establish a contract for the following: Installation of a roof system for the Sugar Grove Salt Shed in Pendleton County, West Virginia. The roof system would be designed and installed to consist of a single span truss arch, fabric covered, steel framed building roof system, to clear span the 42 ft. OD x 32 ft. OD structure, as per the attached Project Plans and documents. Per the bid requirements, Specifications, Terms and Conditions attached to this Solicitation.

INVOICE TO

DIVISION OF HIGHWAYS
 DISTRICT EIGHT - ALL
 LOCATIONS
 PO BOX 1516
 ELKINS WV
 US

SHIP TO

WV DIVISION OF HIGHWAYS
 SUGAR GROVE SUBSTATION
 9315 SUGAR GROVE RD
 SUGAR GROVE WV
 US

Line	Comm Ln Desc	Qty	Unit Issue	Unit Price	Total Price
1	Roofing System	1.00000	EA		\$ 61,649.28

Comm Code	Manufacturer	Specification	Model #
25174100	Brute span		Atlas

Extended Description:

32' x 42' Roofing System for the Sugar Grove Salt Shed

SCHEDULE OF EVENTS

Line	Event	Event Date
1	Pre-bid Meeting 1:00pm - Sugar Grove Salt Shed	2021-07-27
2	Tech Questions due by: 10:00am	2021-08-03

	Document Phase	Document Description	Page 3
DOT2200000020	Final	ADDENDUM NO_3 ROOFING SYSTEM	

ADDITIONAL TERMS AND CONDITIONS

See attached document(s) for additional Terms and Conditions

REQUEST FOR QUOTATION
Pendleton County, Sugar Grove,
Salt Shed Building Roof System

GENERAL CONSTRUCTION SPECIFICATIONS (No AIA Documents)

1. **PURPOSE AND SCOPE:** The West Virginia Purchasing Division is soliciting bids on behalf of West Virginia Division of Highways (WVDOH) to establish a contract for the following:

Installation of a roof system for the Sugar Grove Salt Shed in Pendleton County, West Virginia. The roof system would be designed and installed to consist of a single span truss arch, fabric covered, steel framed building roof system, to clear span the 42 ft. OD x 32 ft. OD structure, as per the attached Project Plans and documents.

The Vendor shall furnish all materials, labor, and equipment necessary to complete all Construction Services. The Vendor shall furnish any incidental work, materials, labor, and equipment that are necessary to complete the Construction Services, even if such incidental work is not explicitly included in the Project Plans.

2. **DEFINITIONS:** The terms listed below shall have the meanings assigned to them below. Additional definitions can be found in section 2 of the General Terms and Conditions and in the Project Plans as defined below.

2.1 **“Construction Services”** means design and installation of any and all aspects of the building roof system, as more fully described in the Project Plans.

2.2 **“Pricing Page”** means the pages contained in WVOASIS, attached hereto as Exhibit A, or included in the Project Plans upon which Vendor should list its proposed price for the Construction Services.

2.3 **“Solicitation”** means the official notice of an opportunity to supply the State with Construction Services that is published by the Purchasing Division.

2.4 **“WVDOH”** means the West Virginia Division of Highways.

2.5 **“Roof System”** means all components comprised in a single span truss arch fabric Covered steel framed building roof system which will be used to cover the Sugar Grove Salt Shed.

2.6 **“ASCE”** means the American Society of Civil Engineers. Reference: www.asce.org

2.7 **“ANSI”** means the American National Standards Institute. Reference: www.ansi.org.

2.8 **“AISC”** means the American Institute of Steel Construction. Reference: www.aisc.org.

2.9 **“AASHTO”** means the American Association of State Highway and Transportation Officials. Reference: www.astm.org.

REQUEST FOR QUOTATION
Pendleton County, Sugar Grove,
Salt Shed Building Roof System

- 2.10 “ASTM” means the American Society for Testing and Materials.
Reference: www.astm.org.
- 2.11 “HSS” means Hollow Structural Steel.
- 2.12 “PSI” means Pounds per Square Inch.
- 2.13 “PSF” means per Square Foot.
- 2.14 “Contractor” or “Vendor” or “Bidder” used throughout this Solicitation and in any cited sections of the West Virginia Department of Transportation, Division of Highways Standard Specifications, Roads, and Bridges, most recent edition, as modified by all subsequent annual supplemental Specifications, are interchangeable.
- 2.15 “Project Plans” means documents developed by an architect, an engineer, the Agency, or another design professional, which are attached hereto as Exhibit B, that provide detailed instructions on how the Construction Services are to be performed. In the event that Project Plans contain drawings or other documents too large to attach in Exhibit B, Vendors can obtain copies in accordance with Section 9 of these Specifications.
3. **ORDER OF PRECEDENCE:** This General Construction Specifications document will have priority over, and supersede, anything contained in the Project Plans.
4. **QUALIFICATIONS:** Vendor, or Vendor’s staff if requirements are inherently limited to individuals rather than corporate entities, shall have the following minimum qualifications:
- 4.1. **Experience:** Vendor, or Vendor’s supervisory staff assigned to this project, must have successfully completed at least six projects that involved work similar to that described in these specifications or the Project Plans. Compliance with this experience requirement will be determined prior to contract award by the State through references provided by the Vendor upon request, through knowledge or documentation of the Vendor’s past projects, through confirmation of experience requirements from the architect assisting the State in this project, or some other method that the State determines to be acceptable. Vendor must provide any documentation requested by the State to assist in confirmation of compliance with this provision. References, documentation, or other information to confirm compliance with this experience requirement may be requested after bid opening and prior to contract award.

REQUEST FOR QUOTATION
Pendleton County, Sugar Grove,
Salt Shed Building Roof System

5. **CONTRACT AWARD:** The Contract is intended to provide Agency with a purchase price for the Construction Services. The Contract will be awarded to the lowest qualified responsible bidder meeting the required specifications. If the Pricing Pages contain alternates/add-ons, the Contract will be awarded based on the grand total of the base bid and any alternates/add-ons selected.
6. **SELECTION OF ALTERNATES:** Pursuant to W. Va. Code § 5-22-1(f), any solicitation of bids shall include no more than five alternates. Alternates, if accepted, shall be accepted in the order in which they are listed on the bid form. Any unaccepted alternate contained within a bid shall expire 90 days after the date of the opening of bids for review. Determination of the lowest qualified responsible bidder shall be based on the sum of the base bid and any alternates accepted.
7. **PERFORMANCE:** Vendor shall perform the Construction Services in accordance with this document and the Project Plans.
8. **SUBSTITUTIONS:** Any substitution requests must be submitted in accordance with the official question and answer period described in the INSTRUCTIONS TO VENDORS SUBMITTING BIDS, Paragraph 4. Vendor Question Deadline. Vendors submitting substitution requests should submit product brochures and product specifications during the official question and answer period.
9. **PROJECT PLANS:** The checked box will apply to Project Plans for this solicitation.
- No Additional Project Plan Documents:** There are no additional Project Plans other than those attached hereto as Exhibit B or any subsequent addenda modifying Exhibit B.
- Additional Project Plan Documents:** There are additional Project Plan documents other than those attached as Exhibit B. Copies of the additional Project Plan documents not attached as Exhibit B can be obtained by contacting the entity identified below.

Copies of project plans can be examined at the following locations

10. CONDITIONS OF THE WORK

- 10.1. **Permits:** The Vendor shall procure all necessary permits and licenses to comply with all applicable Federal, State, or Local laws, regulations and ordinances of any regulating body.
- 10.2. **Existing Conditions:** If discrepancies are discovered between the existing conditions and those noted in the specifications, Vendor must immediately notify the Agency's

REQUEST FOR QUOTATION
Pendleton County, Sugar Grove,
Salt Shed Building Roof System

representative. Vendor must also immediately notify the Agency if suspected hazardous materials are encountered.

10.3. Standard Work Hours: The standard hours of work for this Contract will be Monday – Friday 7 AM – 5 PM excluding holidays recognized by the State of West Virginia. Any work outside of the standard hours of work must be approved in advance at the Agency’s sole discretion. Authorization of work outside of the standard hours of work will not entitle Vendor to additional compensation.

10.4. Project Closeout: Project Closeout shall include the following:

10.4.1. Final Cleanup: Vendor shall perform the final cleanup activities listed below, along with any other final cleanup activities normally associated with the work performed under this Contract, prior to final inspection:

10.4.1.1 Removal of all construction incidental materials from the project site
Is required.

10.4.1.2. Final Inspection: Vendor shall participate in a final inspection with the Agency’s project manager. The purpose of the final inspection will be to identify deficiencies that need to be remedied prior to Agency’s final acceptance of the work. Vendor shall at all times be obligated to perform in accordance with the Contract and must take all actions necessary to ensure that work complies with requirements of Contract prior to final acceptance. Final acceptance does not waive or release Vendor from its obligation to ensure that work complies with the Contract requirements. Vendor shall submit any warranty documents to the Agency project manager at final inspection.

11. FACILITIES ACCESS: Performance of Contract Services may require access cards and/or keys to gain entrance to Agency’s facilities. In the event that access cards and/or keys are required:

11.1. Vendor must identify principal service personnel which will be issued access cards and/or keys to perform service.

11.2. Vendor will be responsible for controlling cards and keys and will pay replacement fee, if the cards or keys become lost or stolen.

11.3. Vendor shall notify Agency immediately of any lost, stolen, or missing card or key.

11.4. Anyone performing under this Contract will be subject to Agency’s security protocol and procedures.

REQUEST FOR QUOTATION
Pendleton County, Sugar Grove,
Salt Shed Building Roof System

11.5. Vendor shall inform all staff of Agency's security protocol and procedures.

12. MISCELLANEOUS:

12.1. **Contract Manager:** During its performance of this Contract, Vendor must designate and maintain a primary contract manager responsible for overseeing Vendor's responsibilities under this Contract. The Contract manager must be available during normal business hours to address any customer service or other issues related to this Contract. Vendor should list its Contract manager and his or her contact information below.

Contract Manager: Nathaniel G. Rohrig

Telephone Number: 304-623-4827

Fax Number: 304-622-5546

Email Address: Nrohrig@aol.com

EXHIBIT C

Public Road Dist.	State Dist. No.	State Project No.	Federal Project No.	Fiscal Year	County	Sheet No.	Total Sheets
W.V.	8	SCCC RR-MULUM		2020	PENDLETON	2	10

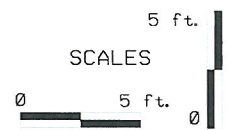
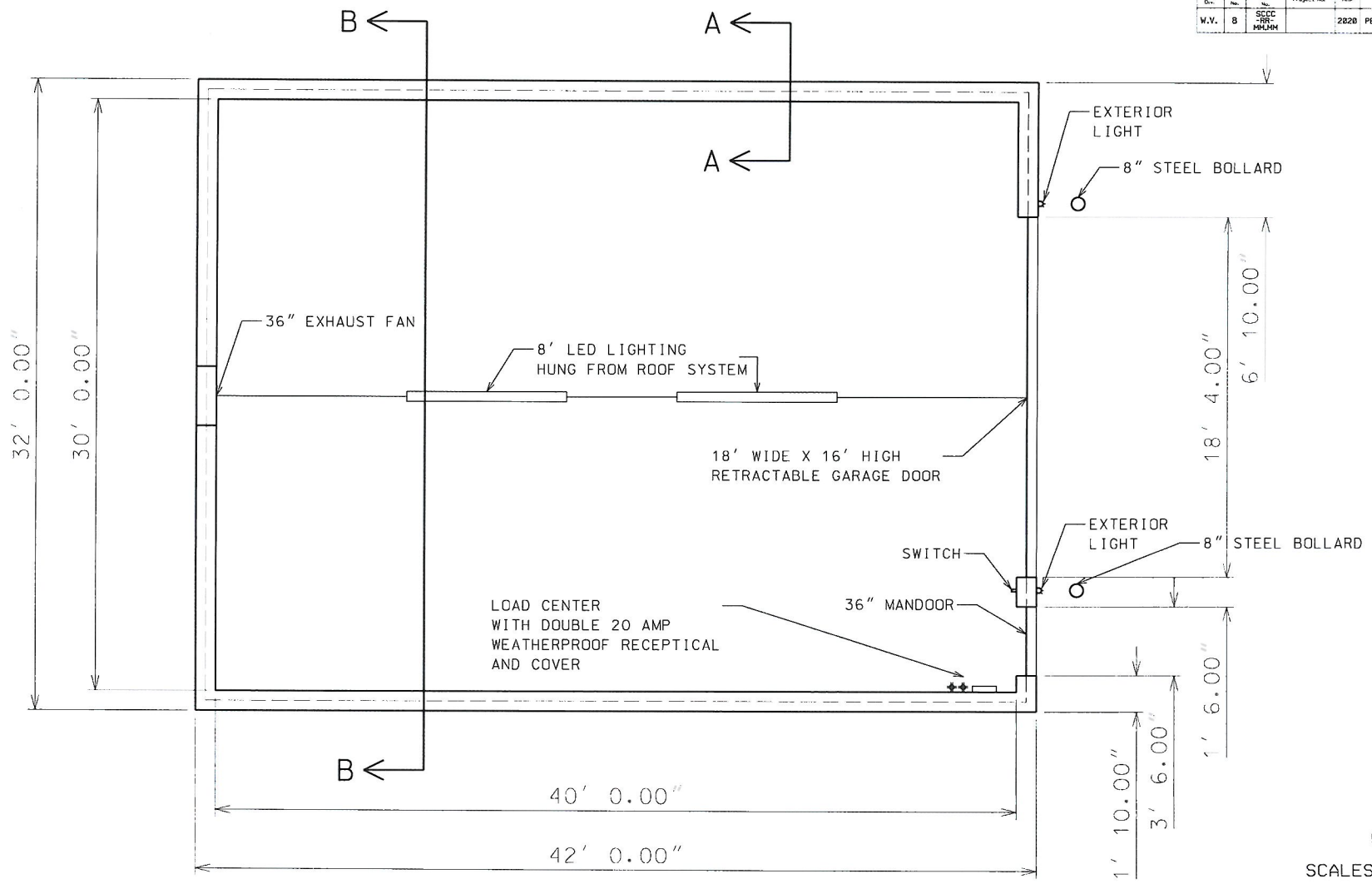

THE WEST VIRGINIA DEPARTMENT OF TRANSPORTATION DIVISION OF HIGHWAYS				
GENERAL LAYOUT				
REVISION NUMBER	SHEET NUMBER	REVISION	DATE	BY

4/20/2020 10:00 AM

EXHIBIT C

Public Road Dist.	State Job No.	State Project No.	Federal Project No.	Fiscal Year	County	Sheet No.	Total Sheets
W.V.	8	SCCC-RR-192424		2020	PENDELTON	4	18

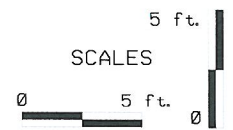
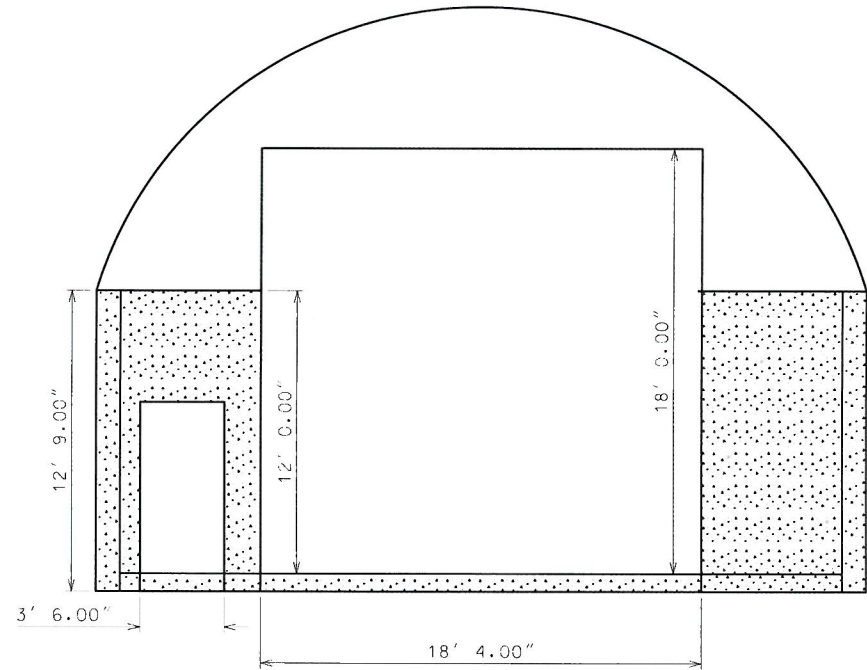
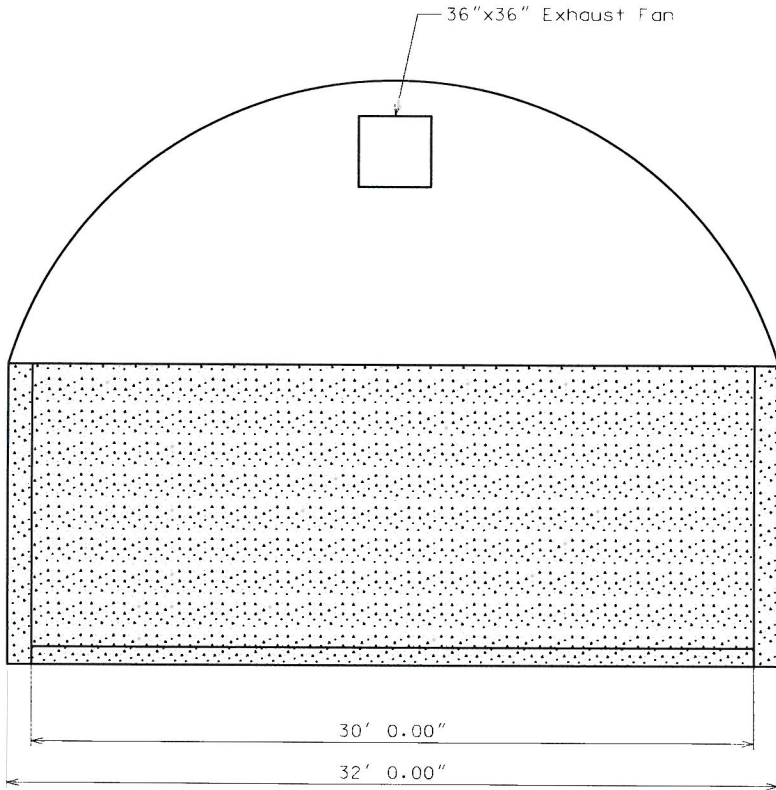

REVISION NUMBER	SHEET NUMBER	REVISION	DATE	BY

THE WEST VIRGINIA DEPARTMENT OF TRANSPORTATION
DIVISION OF HIGHWAYS
CONTROL JOINT LAYOUT

11/11/2021 1:40:28 PM

REQUEST FOR QUOTATION
Pendleton County, Sugar Grove,
Salt Shed Building Roof System

EXHIBIT B – Project Plans

I. CONTRACT REQUIREMENTS

- a. Contract Items and Mandatory Requirement: Contract Items must meet or exceed the mandatory requirements

II. GENERAL REQUIREMENTS

- a. WVDOH constructed a salt shed building per the following dimensions: 42ft x 32ft with one door on one end and a roof system shall be designed and installed accordingly.
- b. The design shall comply with the ASCE 7 Manual on "Minimum Design Loads for Building and Other structures".
 - i. The minimum interior wall height clearance is 12 feet above the finished floor slab. There are no exceptions for less than 12 feet due to shed loading clearance.
 - ii. The minimum wall thickness is 12 inches
 - iii. The minimum interior clearance required at the apex of the arch shall be as follows: 23.0'
 - iv. In addition to the design loads required by the building code, a ground snow load of 35 PSF shall be utilized unless otherwise required by state or local code. The load combinations shall be as specified in the applicable building code(s). See WV Code 29-3-5b1 and the WV State Fire Commission State Building Code. These websites are referenced at the end of this document.

III. STEEL FRAME REQUIREMENTS

- a. Each member must be designed to withstand the stresses resulting from combinations of loads that produce maximum allowable stresses in that member.
- b. Each assembly shall be properly piece-marked to assist with the identification and erection of the roof system. Piece-marks by secured tagging or welding practices (prior to final coating of assembly) shall be labeled in clear, easily identifiable locations.
- c. Structural steel must comply with ANSI/AISC 360, Specification for Structural Steel Buildings, most recent editions for design requirements and allowable stresses.
- d. Welded connections must comply with the most recent editions of the provisions of ANSI/AISC 360, Specification of Structural Steel Buildings.
- e. The entire system shall be galvanized to resist corrosion from road salt stored within the structure in accordance with ASTM A123, Standard Specification for Zinc (Hot-Dip Galvanized) Coating on Iron and Steel Products. All fasteners shall be galvanized in accordance with ASTM A153, Standard Specification for Zinc (Hot-Dip Galvanized) Coatings on Iron and Steel Hardware.
- f. Steel tubing cross members and back wall framing members shall comply with ASTM 500, Grade B, ASTM A501, or ASTM A53.
- g. Steel connection members shall be fabricated from plate or bar stock and provide 42,000 PSI minimum yield strength and comply with ASTM A529, ASTM A570 or ASTM A572.

**REQUEST FOR QUOTATION
Pendleton County, Sugar Grove,
Salt Shed Building Roof System**

- h. Bolts for structural framing shall comply with ASTM A307 or ASTM A325 specifications as necessary for the design loads and connections details, including bolts for use in corrosive environment.
- i. The system is to include HSS end wall steel and fabric on both ends. The back shall be totally enclosed.
- j. The front wall shall include a double-slide or double swing door, centered along the front wall, at no less than 18' x 18' opening. Should double-slide doors be proposed, door system shall include an upper shield or shed-style canopy to protect the door rolling mechanisms from outdoor weather elements. The door proposed must accommodate manual operation without assistance from powered operators or winch systems.
- k. The back wall shall include a 36" x 36" opening, as shown in the attached drawings. The opening and all necessary support structure will be designed to accommodate and support an exhaust fan of that size and weight. The 36" x 36" exhaust fan will be supplied and installed and tested in place by the contractor and it will be suitable for use in the corrosive salt shed environment and will be incidental to the Roof System Line Item no. 1 bid price. WVDOH will complete the electrical connections necessary for the permanent exhaust fan operation.

IV. INDUSTRIAL FABRIC COVER REQUIREMENTS

- a. The industrial fabric cover shall be woven high density polyethylene tape with double stack weave-finish coated sided, meeting or exceeding the specs listed below:

Weave	16 x 16 psi woven clear HDPE scrim	
Coating Thickness	4.0mil average each side (94 g/m ²)	
Coating Composition	Modified LDPE coating with UV protection	
Weight	12.5 oz/yd ² (373 g/m ²) +/-5%	
Thickness	23 mils (0.635mm)	ASTM
D5199 Hydrostatic Resistance		
Method	171 psi (1180 kPa)	ASTM D751A
Grab Tensile	Warp: 340 lbs. (1511 N)	ASTM D5034
	Weft: 340 lbs. (1511 N)	ASTM D5034
Strip Tensile	Warp: 250 lbs. (1112 N)	ASTM D5035
	Weft: 250 lbs. (1112 N)	ASTM D5035
Tongue Tear	Warp: 115 lbs. (511 N)	ASTM D2261
	Weft: 115 lbs. (511 N)	ASTM D2261
Mullen Burst	675 psi (4658 kPa)	ASTM D2136
Cold Crack	Minus 60° C	ASTM D2136

Fire Rating:			
<u>Test/Standard</u>	<u>Flame Spread</u>	<u>Smoke Developed</u>	<u>Char Length</u>
ASTM E84	FS10	SD 58	6.5

**REQUEST FOR QUOTATION
Pendleton County, Sugar Grove,
Salt Shed Building Roof System**

- b. The cover fastening system shall be compatible with the specifications above including zero-stretch belting, welded fabric pockets and 10,000-pound capacity lashing winches coated to prevent corrosion.
- c. The system shall include aluminum flat bar for fabric termination around entire building.
- d. The color of the fabric cover shall be tan with green trim. Prior to contract award, color samples may be requested by the WVDOH for review and approval by the WVDOH.
- e. The warranty period for the industrial cover shall be fifteen (15) years. The awarded vender shall provide a copy of this warranty.
- f. The awarded vendor is responsible for all repairs at no additional cost to the WVDOH.
 - i. Permanent fabric repair service shall be handled by the Vendor within five (5) working days after the Vendor is contacted by the WVDOH. Temporary patching* shall only be used when conditions do not permit permanent repair (such as temperatures). Permanent repair shall be made as soon as conditions are appropriate for successful repair. Alternative temporary repair dates and permanent repair dates may be agreed upon by the WVDOH and the Vendor.
 - ii. NOTE: Temporary Patching such as the use of Duct Tape is not acceptable

V. SHOP DRAWINGS

- a. Sample Shop Drawings. Vendor sample shop drawings should be submitted with the Vendor's bid. If sample shop drawings are not submitted with the Vendor's bid, the vendor shall provide the sample within five calendar days after request by the Purchasing Division. Vendor shop drawings shall indicate pertinent criteria, reaction and other information required for fabrication installation and as required by codes. The sample shop drawings shall identify the construction and in- place loads for consideration with the salt shed building design. The shop drawings shall identify the specific slide and/or swing type function for the front door. The door proposed must accommodate manual operation without assistance from powered operators or winch systems.
- b. Project Specific Shop Drawings. All project specific shop drawings, from the awarded vendor must be signed and sealed by a Professional Engineer registered in the state of West Virginia. Review and approval of project specific shop drawings will be conducted by the WVDOH.

VI. QUALIFICATIONS

- a. Certification
 - i. At the time of the bid, the bidder must be currently certified, at a minimum to ISO 9001:2008 Quality Management Systems standards and should provide a copy of that certification with their bid. The Vendor shall have direct experience in the design, manufacture, and installation of structures of the type specified herein; shall operate according to a comprehensive quality system. If a copy of the Vendors certification is not submitted with the Vendor's bid, the Vendor shall provide the certification copy within five calendar days after requested by the Purchasing Division. Whether ISO 9001:2008 Quality Management systems

**REQUEST FOR QUOTATION
Pendleton County, Sugar Grove,
Salt Shed Building Roof System**

standards certification or equivalent or substitute certification, the bidder should provide the name of this certification on Exhibit B information Attachment Form. If the Vendor does not provide the name of the certification on the Information Attachment Form submitted with their bid the Vendor shall provide the name of the certification within five calendar days after the request by the Purchasing Division. Whether ISO 9001:2008 certified, equivalent or substitute, the certification must continue throughout the term of this contract. Upon any renewal of the certification, a copy of the certification must be sent to the WVDOH.

b. Structure References

- i. The bidder should provide three references with structures in use for at least five (5) years which are of similar design, function, and size on the Exhibit B Information Attachment Form. If the Vendor does not provide three references on the Information Attachment Form submitted with their bid, the Vendor shall provide three references within five calendar days after request by the Purchasing Division.

EXHIBIT A

Pricing Page
RFQ #0821-0631

Item No.	Quantity	Units	Description	Unit Cost	Total
1	1	EA	Size 32' x 42' Roofing System for the Sugar Grove Salt Shed		\$61,649.28
2					\$0.00
3					\$0.00
4					\$0.00
5					\$0.00
6					\$0.00
			Items for Sugar Grove Salt Shed Roof		
			Grand Total	→	\$61,649.28

INSTRUCTIONS TO VENDORS SUBMITTING BIDS

1. REVIEW DOCUMENTS THOROUGHLY: The attached documents contain a solicitation for bids. Please read these instructions and all documents attached in their entirety. These instructions provide critical information about requirements that if overlooked could lead to disqualification of a Vendor's bid. All bids must be submitted in accordance with the provisions contained in these instructions and the Solicitation. Failure to do so may result in disqualification of Vendor's bid.

2. MANDATORY TERMS: The Solicitation may contain mandatory provisions identified by the use of the words "must," "will," and "shall." Failure to comply with a mandatory term in the Solicitation will result in bid disqualification.

3. PREBID MEETING: The item identified below shall apply to this Solicitation.

A pre-bid meeting will not be held prior to bid opening

A MANDATORY PRE-BID meeting will be held at the following place and time:

DOH
Sugar Grove Substation
9315 Sugar Grove Road
Sugar Grove WV, 26815
July 27, 2021 @ 1:00 PM

All Vendors submitting a bid must attend the mandatory pre-bid meeting. Failure to attend the mandatory pre-bid meeting shall result in disqualification of the Vendor's bid. No one individual is permitted to represent more than one vendor at the pre-bid meeting. Any individual that does attempt to represent two or more vendors will be required to select one vendor to which the individual's attendance will be attributed. The vendors not selected will be deemed to have not attended the pre-bid meeting unless another individual attended on their behalf.

An attendance sheet provided at the pre-bid meeting shall serve as the official document verifying attendance. Any person attending the pre-bid meeting on behalf of a Vendor must list on the attendance sheet his or her name and the name of the Vendor he or she is representing.

Additionally, the person attending the pre-bid meeting should include the Vendor's E-Mail address, phone number, and Fax number on the attendance sheet. It is the Vendor's responsibility to locate the attendance sheet and provide the required information. Failure to complete the attendance sheet as required may result in disqualification of Vendor's bid.

All Vendors should arrive prior to the starting time for the pre-bid. Vendors who arrive after the starting time but prior to the end of the pre-bid will be permitted to sign in but are charged with knowing all matters discussed at the pre-bid.

Questions submitted at least five business days prior to a scheduled pre-bid will be discussed at the pre-bid meeting if possible. Any discussions or answers to questions at the pre-bid meeting
Revised 07/01/2021

are preliminary in nature and are non-binding. Official and binding answers to questions will be published in a written addendum to the Solicitation prior to bid opening.

4. VENDOR QUESTION DEADLINE: Vendors may submit questions relating to this Solicitation to the Purchasing Division. Questions must be submitted in writing. All questions must be submitted on or before the date listed below and to the address listed below to be considered. A written response will be published in a Solicitation addendum if a response is possible and appropriate. Non-written discussions, conversations, or questions and answers regarding this Solicitation are preliminary in nature and are nonbinding.

Submitted e-mails should have solicitation number in the subject line.

Question Submission Deadline: August 3, 2021 by 10:00am

Submit Questions to: John Estep
2019 Washington Street, East
Charleston, WV 25305
Fax: (304) 558-4115 (Vendors should not use this fax number for bid submission)
Email: john.w.estep@wv.gov

5. VERBAL COMMUNICATION: Any verbal communication between the Vendor and any State personnel is not binding, including verbal communication at the mandatory pre-bid conference. Only information issued in writing and added to the Solicitation by an official written addendum by the Purchasing Division is binding.

6. BID SUBMISSION: All bids must be submitted electronically through wvOASIS or signed and delivered by the Vendor to the Purchasing Division at the address listed below on or before the date and time of the bid opening. Any bid received by the Purchasing Division staff is considered to be in the possession of the Purchasing Division and will not be returned for any reason. The Purchasing Division will not accept bids, modification of bids, or addendum acknowledgment forms via e-mail. Acceptable delivery methods include electronic submission via wvOASIS, hand delivery, delivery by courier, or facsimile.

The bid delivery address is:
Department of Administration, Purchasing Division
2019 Washington Street East
Charleston, WV 25305-0130

A bid that is not submitted electronically through wvOASIS should contain the information listed below on the face of the envelope or the bid may be rejected by the Purchasing Division.:

SEALED BID:	Roofing System - Sugar Grove Salt Shed
BUYER:	John Estep
SOLICITATION NO.:	CRFQ 0803 DOT2200000020
BID OPENING DATE:	August 17, 2021
BID OPENING TIME:	1:30 PM
FAX NUMBER:	304-558-3970

Revised 07/01/2021

The Purchasing Division may prohibit the submission of bids electronically through wvOASIS at its sole discretion. Such a prohibition will be contained and communicated in the wvOASIS system resulting in the Vendor's inability to submit bids through wvOASIS. Submission of a response to a Request for Proposal is not permitted in wvOASIS.

For Request For Proposal ("RFP") Responses Only: In the event that Vendor is responding to a request for proposal, the Vendor shall submit one original technical and one original cost proposal prior to the bid opening date and time identified in Section 7 below, plus _____ convenience copies of each to the Purchasing Division at the address shown above. Additionally, the Vendor should clearly identify and segregate the cost proposal from the technical proposal in a separately sealed envelope.

7. BID OPENING: Bids submitted in response to this Solicitation will be opened at the location identified below on the date and time listed below. Delivery of a bid after the bid opening date and time will result in bid disqualification. For purposes of this Solicitation, a bid is considered delivered when confirmation of delivery is provided by wvOASIS (in the case of electronic submission) or when the bid is time stamped by the official Purchasing Division time clock (in the case of hand delivery).

Bid Opening Date and Time: August 17, 2021 @ 1:30pm

Bid Opening Location: Department of Administration, Purchasing Division
2019 Washington Street East
Charleston, WV 25305-0130

8. ADDENDUM ACKNOWLEDGEMENT: Changes or revisions to this Solicitation will be made by an official written addendum issued by the Purchasing Division. Vendor should acknowledge receipt of all addenda issued with this Solicitation by completing an Addendum Acknowledgment Form, a copy of which is included herewith. Failure to acknowledge addenda may result in bid disqualification. The addendum acknowledgement should be submitted with the bid to expedite document processing.

9. BID FORMATTING: Vendor should type or electronically enter the information onto its bid to prevent errors in the evaluation. Failure to type or electronically enter the information may result in bid disqualification.

10. ALTERNATE MODEL OR BRAND: Unless the box below is checked, any model, brand, or specification listed in this Solicitation establishes the acceptable level of quality only and is not intended to reflect a preference for, or in any way favor, a particular brand or vendor. Vendors may bid alternates to a listed model or brand provided that the alternate is at least equal to the model or brand and complies with the required specifications. The equality of any alternate being bid shall be determined by the State at its sole discretion. Any Vendor bidding an alternate model or brand should clearly identify the alternate items in its bid and should include manufacturer's specifications, industry literature, and/or any other relevant documentation demonstrating the equality of the alternate items. Failure to provide information for alternate items may be grounds for rejection of a Vendor's bid.

This Solicitation is based upon a standardized commodity established under W. Va. Code § 5A-3-61. Vendors are expected to bid the standardized commodity identified. Failure to bid the standardized commodity will result in your firm's bid being rejected.

11. EXCEPTIONS AND CLARIFICATIONS: The Solicitation contains the specifications that shall form the basis of a contractual agreement. Vendor shall clearly mark any exceptions, clarifications, or other proposed modifications in its bid. Exceptions to, clarifications of, or modifications of a requirement or term and condition of the Solicitation may result in bid disqualification.

12. COMMUNICATION LIMITATIONS: In accordance with West Virginia Code of State Rules §148-1-6.6, communication with the State of West Virginia or any of its employees regarding this Solicitation during the solicitation, bid, evaluation or award periods, except through the Purchasing Division, is strictly prohibited without prior Purchasing Division approval. Purchasing Division approval for such communication is implied for all agency delegated and exempt purchases.

13. REGISTRATION: Prior to Contract award, the apparent successful Vendor must be properly registered with the West Virginia Purchasing Division and must have paid the \$125 fee, if applicable.

14. UNIT PRICE: Unit prices shall prevail in cases of a discrepancy in the Vendor's bid.

15. PREFERENCE: Vendor Preference may be requested in purchases of motor vehicles or construction and maintenance equipment and machinery used in highway and other infrastructure projects. Any request for preference must be submitted in writing with the bid, must specifically identify the preference requested with reference to the applicable subsection of West Virginia Code § 5A-3-37, and must include with the bid any information necessary to evaluate and confirm the applicability of the requested preference. A request form to help facilitate the request can be found at:

<http://www.state.wv.us/admin/purchase/vrc/Venpref.pdf>.

15A. RECIPROCAL PREFERENCE: The State of West Virginia applies a reciprocal preference to all solicitations for commodities and printing in accordance with W. Va. Code § 5A-3-37(b). In effect, non-resident vendors receiving a preference in their home states, will see that same preference granted to West Virginia resident vendors bidding against them in West Virginia. Any request for reciprocal preference must include with the bid any information necessary to evaluate and confirm the applicability of the preference. A request form to help facilitate the request can be found at: <http://www.state.wv.us/admin/purchase/vrc/Venpref.pdf>.

16. SMALL, WOMEN-OWNED, OR MINORITY-OWNED BUSINESSES: For any solicitations publicly advertised for bid, in accordance with West Virginia Code §5A-3-37(a)(7) and W. Va. CSR § 148-22-9, any non-resident vendor certified as a small, women-owned, or minority-owned business under W. Va. CSR § 148-22-9 shall be provided the same preference made available to any resident vendor. Any non-resident small, women-owned, or minority-owned business must identify itself as such in writing, must submit that writing to the Purchasing Division with its bid, and must be properly certified under W. Va. CSR § 148-22-9 prior to contract award to receive the preferences made available to resident vendors. Preference

for a non-resident small, women-owned, or minority owned business shall be applied in accordance with W. Va. CSR § 148-22-9.

17. WAIVER OF MINOR IRREGULARITIES: The Director reserves the right to waive minor irregularities in bids or specifications in accordance with West Virginia Code of State Rules § 148-1-4.6.

18. ELECTRONIC FILE ACCESS RESTRICTIONS: Vendor must ensure that its submission in wvOASIS can be accessed and viewed by the Purchasing Division staff immediately upon bid opening. The Purchasing Division will consider any file that cannot be immediately accessed and viewed at the time of the bid opening (such as, encrypted files, password protected files, or incompatible files) to be blank or incomplete as context requires, and are therefore unacceptable. A vendor will not be permitted to unencrypt files, remove password protections, or resubmit documents after bid opening to make a file viewable if those documents are required with the bid. A Vendor may be required to provide document passwords or remove access restrictions to allow the Purchasing Division to print or electronically save documents provided that those documents are viewable by the Purchasing Division prior to obtaining the password or removing the access restriction.

19. NON-RESPONSIBLE: The Purchasing Division Director reserves the right to reject the bid of any vendor as Non-Responsible in accordance with W. Va. Code of State Rules § 148-1-5.3, when the Director determines that the vendor submitting the bid does not have the capability to fully perform or lacks the integrity and reliability to assure good-faith performance.”

20. ACCEPTANCE/REJECTION: The State may accept or reject any bid in whole, or in part in accordance with W. Va. Code of State Rules § 148-1-4.5. and § 148-1-6.4.b.”

21. YOUR SUBMISSION IS A PUBLIC DOCUMENT: Vendor’s entire response to the Solicitation and the resulting Contract are public documents. As public documents, they will be disclosed to the public following the bid/proposal opening or award of the contract, as required by the competitive bidding laws of West Virginia Code §§ 5A-3-1 et seq., 5-22-1 et seq., and 5G-1-1 et seq. and the Freedom of Information Act West Virginia Code §§ 29B-1-1 et seq.

DO NOT SUBMIT MATERIAL YOU CONSIDER TO BE CONFIDENTIAL, A TRADE SECRET, OR OTHERWISE NOT SUBJECT TO PUBLIC DISCLOSURE.

Submission of any bid, proposal, or other document to the Purchasing Division constitutes your explicit consent to the subsequent public disclosure of the bid, proposal, or document. The Purchasing Division will disclose any document labeled “confidential,” “proprietary,” “trade secret,” “private,” or labeled with any other claim against public disclosure of the documents, to include any “trade secrets” as defined by West Virginia Code § 47-22-1 et seq. All submissions are subject to public disclosure without notice.

22. INTERESTED PARTY DISCLOSURE: West Virginia Code § 6D-1-2 requires that the vendor submit to the Purchasing Division a disclosure of interested parties to the contract for all contracts with an actual or estimated value of at least \$1 million. That disclosure must occur on the form prescribed and approved by the WV Ethics Commission prior to contract award.

A copy of that form is included with this solicitation or can be obtained from the WV Ethics Commission. This requirement does not apply to publicly traded companies listed on a national or international stock exchange. A more detailed definition of interested parties can be obtained from the form referenced above.

23. WITH THE BID REQUIREMENTS: In instances where these specifications require documentation or other information with the bid, and a vendor fails to provide it with the bid, the Director of the Purchasing Division reserves the right to request those items after bid opening and prior to contract award pursuant to the authority to waive minor irregularities in bids or specifications under W. Va. CSR § 148-1-4.6. This authority does not apply to instances where state law mandates receipt with the bid.

24. E-MAIL NOTIFICATION OF AWARD: The Purchasing Division will attempt to provide bidders with e-mail notification of contract award when a solicitation that the bidder participated in has been awarded. For notification purposes, bidders must provide the Purchasing Division with a valid email address in the bid response. Bidders may also monitor wvOASIS or the Purchasing Division's website to determine when a contract has been awarded.

GENERAL TERMS AND CONDITIONS:

1. CONTRACTUAL AGREEMENT: Issuance of an Award Document signed by the Purchasing Division Director, or his designee, and approved as to form by the Attorney General's office constitutes acceptance by the State of this Contract made by and between the State of West Virginia and the Vendor. Vendor's signature on its bid, or on the Contract if the Contract is not the result of a bid solicitation, signifies Vendor's agreement to be bound by and accept the terms and conditions contained in this Contract.

2. DEFINITIONS: As used in this Solicitation/Contract, the following terms shall have the meanings attributed to them below. Additional definitions may be found in the specifications included with this Solicitation/Contract.

2.1. "Agency" or "Agencies" means the agency, board, commission, or other entity of the State of West Virginia that is identified on the first page of the Solicitation or any other public entity seeking to procure goods or services under this Contract.

2.2. "Bid" or "Proposal" means the vendors submitted response to this solicitation.

2.3. "Contract" means the binding agreement that is entered into between the State and the Vendor to provide the goods or services requested in the Solicitation.

2.4. "Director" means the Director of the West Virginia Department of Administration, Purchasing Division.

2.5. "Purchasing Division" means the West Virginia Department of Administration, Purchasing Division.

2.6. "Award Document" means the document signed by the Agency and the Purchasing Division, and approved as to form by the Attorney General, that identifies the Vendor as the contract holder.

2.7. "Solicitation" means the official notice of an opportunity to supply the State with goods or services that is published by the Purchasing Division.

2.8. "State" means the State of West Virginia and/or any of its agencies, commissions, boards, etc. as context requires.

2.9. "Vendor" or "Vendors" means any entity submitting a bid in response to the Solicitation, the entity that has been selected as the lowest responsible bidder, or the entity that has been awarded the Contract as context requires.

3. CONTRACT TERM; RENEWAL; EXTENSION: The term of this Contract shall be determined in accordance with the category that has been identified as applicable to this Contract below:

Term Contract

Initial Contract Term: This Contract becomes effective on _____ and the initial contract term extends until _____.

Renewal Term: This Contract may be renewed upon the mutual written consent of the Agency, and the Vendor, with approval of the Purchasing Division and the Attorney General's office (Attorney General approval is as to form only). Any request for renewal should be delivered to the Agency and then submitted to the Purchasing Division thirty (30) days prior to the expiration date of the initial contract term or appropriate renewal term. A Contract renewal shall be in accordance with the terms and conditions of the original contract. Unless otherwise specified below, renewal of this Contract is limited to _____ successive one (1) year periods or multiple renewal periods of less than one year, provided that the multiple renewal periods do not exceed the total number of months available in all renewal years combined. Automatic renewal of this Contract is prohibited. Renewals must be approved by the Vendor, Agency, Purchasing Division and Attorney General's office (Attorney General approval is as to form only)

Alternate Renewal Term – This contract may be renewed for _____ successive _____ year periods or shorter periods provided that they do not exceed the total number of months contained in all available renewals. Automatic renewal of this Contract is prohibited. Renewals must be approved by the Vendor, Agency, Purchasing Division and Attorney General's office (Attorney General approval is as to form only)

Delivery Order Limitations: In the event that this contract permits delivery orders, a delivery order may only be issued during the time this Contract is in effect. Any delivery order issued within one year of the expiration of this Contract shall be effective for one year from the date the delivery order is issued. No delivery order may be extended beyond one year after this Contract has expired.

Fixed Period Contract: This Contract becomes effective upon Vendor's receipt of the notice to proceed and must be completed within ³⁰_____ days.

Fixed Period Contract with Renewals: This Contract becomes effective upon Vendor's receipt of the notice to proceed and part of the Contract more fully described in the attached specifications must be completed within _____ days. Upon completion of the work covered by the preceding sentence, the vendor agrees that maintenance, monitoring, or warranty services will be provided for _____ year(s) thereafter.

One Time Purchase: The term of this Contract shall run from the issuance of the Award Document until all of the goods contracted for have been delivered, but in no event will this Contract extend for more than one fiscal year.

Other: See attached _____
Revised 07/01/2021

4. AUTHORITY TO PROCEED: Vendor is authorized to begin performance of this contract on the date of encumbrance listed on the front page of the Award Document unless either the box for “Fixed Period Contract” or “Fixed Period Contract with Renewals” has been checked in Section 3 above. If either “Fixed Period Contract” or “Fixed Period Contract with Renewals” has been checked, Vendor must not begin work until it receives a separate notice to proceed from the State. The notice to proceed will then be incorporated into the Contract via change order to memorialize the official date that work commenced.

5. QUANTITIES: The quantities required under this Contract shall be determined in accordance with the category that has been identified as applicable to this Contract below.

Open End Contract: Quantities listed in this Solicitation/Award Document are approximations only, based on estimates supplied by the Agency. It is understood and agreed that the Contract shall cover the quantities actually ordered for delivery during the term of the Contract, whether more or less than the quantities shown.

Service: The scope of the service to be provided will be more clearly defined in the specifications included herewith.

Combined Service and Goods: The scope of the service and deliverable goods to be provided will be more clearly defined in the specifications included herewith.

One Time Purchase: This Contract is for the purchase of a set quantity of goods that are identified in the specifications included herewith. Once those items have been delivered, no additional goods may be procured under this Contract without an appropriate change order approved by the Vendor, Agency, Purchasing Division, and Attorney General’s office.

6. EMERGENCY PURCHASES: The Purchasing Division Director may authorize the Agency to purchase goods or services in the open market that Vendor would otherwise provide under this Contract if those goods or services are for immediate or expedited delivery in an emergency. Emergencies shall include, but are not limited to, delays in transportation or an unanticipated increase in the volume of work. An emergency purchase in the open market, approved by the Purchasing Division Director, shall not constitute a breach of this Contract and shall not entitle the Vendor to any form of compensation or damages. This provision does not excuse the State from fulfilling its obligations under a One Time Purchase contract.

7. REQUIRED DOCUMENTS: All of the items checked below must be provided to the Purchasing Division by the Vendor as specified below.

BID BOND (Construction Only): Pursuant to the requirements contained in W. Va. Code § 5-22-1(c), All Vendors submitting a bid on a construction project shall furnish a valid bid bond in the amount of five percent (5%) of the total amount of the bid protecting the State of West Virginia. The bid bond must be submitted with the bid.

PERFORMANCE BOND: The apparent successful Vendor shall provide a performance bond in the amount of 100% of the contract. The performance bond must be received by the Purchasing Division prior to Contract award.

LABOR/MATERIAL PAYMENT BOND: The apparent successful Vendor shall provide a labor/material payment bond in the amount of 100% of the Contract value. The labor/material payment bond must be delivered to the Purchasing Division prior to Contract award.

In lieu of the Bid Bond, Performance Bond, and Labor/Material Payment Bond, the Vendor may provide certified checks, cashier's checks, or irrevocable letters of credit. Any certified check, cashier's check, or irrevocable letter of credit provided in lieu of a bond must be of the same amount and delivered on the same schedule as the bond it replaces. A letter of credit submitted in lieu of a performance and labor/material payment bond will only be allowed for projects under \$100,000. Personal or business checks are not acceptable. Notwithstanding the foregoing, West Virginia Code § 5-22-1 (d) mandates that a vendor provide a performance and labor/material payment bond for construction projects. Accordingly, substitutions for the performance and labor/material payment bonds for construction projects is not permitted.

MAINTENANCE BOND: The apparent successful Vendor shall provide a two (2) year maintenance bond covering the roofing system. The maintenance bond must be issued and delivered to the Purchasing Division prior to Contract award.

LICENSE(S) / CERTIFICATIONS / PERMITS: In addition to anything required under the Section of the General Terms and Conditions entitled Licensing, the apparent successful Vendor shall furnish proof of the following licenses, certifications, and/or permits upon request and in a form acceptable to the State. The request may be prior to or after contract award at the State's sole discretion.

WV General Contractors License

The apparent successful Vendor shall also furnish proof of any additional licenses or certifications contained in the specifications regardless of whether or not that requirement is listed above.

8. INSURANCE: The apparent successful Vendor shall furnish proof of the insurance identified by a checkmark below and must include the State as an additional insured on each policy prior to Contract award. The insurance coverages identified below must be maintained throughout the life of this contract. Thirty (30) days prior to the expiration of the insurance policies, Vendor shall provide the Agency with proof that the insurance mandated herein has been continued. Vendor must also provide Agency with immediate notice of any changes in its insurance policies, including but not limited to, policy cancelation, policy reduction, or change in insurers. The apparent successful Vendor shall also furnish proof of any additional insurance requirements contained in the specifications prior to Contract award regardless of whether that insurance requirement is listed in this section.

Vendor must maintain:

Commercial General Liability Insurance in at least an amount of: \$100,000.00 per occurrence.

Automobile Liability Insurance in at least an amount of: _____ per occurrence.

Professional/Malpractice/Errors and Omission Insurance in at least an amount of: _____ per occurrence. Notwithstanding the forgoing, Vendor's are not required to list the State as an additional insured for this type of policy.

Commercial Crime and Third Party Fidelity Insurance in an amount of: _____ per occurrence.

Cyber Liability Insurance in an amount of: _____ per occurrence.

Builders Risk Insurance in an amount equal to 100% of the amount of the Contract.

Pollution Insurance in an amount of: _____ per occurrence.

Aircraft Liability in an amount of: _____ per occurrence.

State of West Virginia must be listed as additional insured on insurance certificate. Certificate Holder should read as follows:

State of WV
1900 Kanawha Blvd. E., Bldg. 5
Charleston, WV 25305

Notwithstanding anything contained in this section to the contrary, the Director of the Purchasing Division reserves the right to waive the requirement that the State be named as an additional insured on one or more of the Vendor's insurance policies if the Director finds that doing so is in the State's best interest.

9. WORKERS' COMPENSATION INSURANCE: Vendor shall comply with laws relating to workers compensation, shall maintain workers' compensation insurance when required, and shall furnish proof of workers' compensation insurance upon request.

10. [Reserved]

11. LIQUIDATED DAMAGES: This clause shall in no way be considered exclusive and shall not limit the State or Agency's right to pursue any other available remedy. Vendor shall pay liquidated damages in the amount specified below or as described in the specifications:

\$40.00 per day _____ for _____ period of contract _____.

Liquidated Damages Contained in the Specifications.

Liquidated Damages Are Not Included in this Contract.

12. ACCEPTANCE: Vendor's signature on its bid, or on the certification and signature page, constitutes an offer to the State that cannot be unilaterally withdrawn, signifies that the product or service proposed by vendor meets the mandatory requirements contained in the Solicitation for that product or service, unless otherwise indicated, and signifies acceptance of the terms and conditions contained in the Solicitation unless otherwise indicated.

13. PRICING: The pricing set forth herein is firm for the life of the Contract, unless specified elsewhere within this Solicitation/Contract by the State. A Vendor's inclusion of price adjustment provisions in its bid, without an express authorization from the State in the Solicitation to do so, may result in bid disqualification. Notwithstanding the foregoing, Vendor must extend any publicly advertised sale price to the State and invoice at the lower of the contract price or the publicly advertised sale price.

14. PAYMENT IN ARREARS: Payments for goods/services will be made in arrears only upon receipt of a proper invoice, detailing the goods/services provided or receipt of the goods/services, whichever is later. Notwithstanding the foregoing, payments for software maintenance, licenses, or subscriptions may be paid annually in advance.

15. PAYMENT METHODS: Vendor must accept payment by electronic funds transfer and P-Card. (The State of West Virginia's Purchasing Card program, administered under contract by a banking institution, processes payment for goods and services through state designated credit cards.)

16. TAXES: The Vendor shall pay any applicable sales, use, personal property or any other taxes arising out of this Contract and the transactions contemplated thereby. The State of West Virginia is exempt from federal and state taxes and will not pay or reimburse such taxes.

17. ADDITIONAL FEES: Vendor is not permitted to charge additional fees or assess additional charges that were not either expressly provided for in the solicitation published by the State of West Virginia, included in the Contract, or included in the unit price or lump sum bid amount that Vendor is required by the solicitation to provide. Including such fees or charges as notes to the solicitation may result in rejection of vendor's bid. Requesting such fees or charges be paid after the contract has been awarded may result in cancellation of the contract.

18. FUNDING: This Contract shall continue for the term stated herein, contingent upon funds being appropriated by the Legislature or otherwise being made available. In the event funds are not appropriated or otherwise made available, this Contract becomes void and of no effect beginning on July 1 of the fiscal year for which funding has not been appropriated or otherwise made available. If that occurs, the State may notify the Vendor that an alternative source of funding has been obtained and thereby avoid the automatic termination. Non-appropriation or non-funding shall not be considered an event of default.

19. CANCELLATION: The Purchasing Division Director reserves the right to cancel this Contract immediately upon written notice to the vendor if the materials or workmanship supplied do not conform to the specifications contained in the Contract. The Purchasing Division Director may also cancel any purchase or Contract upon 30 days written notice to the Vendor in accordance with West Virginia Code of State Rules § 148-1-5.2.b.

20. TIME: Time is of the essence regarding all matters of time and performance in this Contract.

21. APPLICABLE LAW: This Contract is governed by and interpreted under West Virginia law without giving effect to its choice of law principles. Any information provided in specification manuals, or any other source, verbal or written, which contradicts or violates the West Virginia Constitution, West Virginia Code, or West Virginia Code of State Rules is void and of no effect.

22. COMPLIANCE WITH LAWS: Vendor shall comply with all applicable federal, state, and local laws, regulations and ordinances. By submitting a bid, Vendor acknowledges that it has reviewed, understands, and will comply with all applicable laws, regulations, and ordinances.

SUBCONTRACTOR COMPLIANCE: Vendor shall notify all subcontractors providing commodities or services related to this Contract that as subcontractors, they too are required to comply with all applicable laws, regulations, and ordinances. Notification under this provision must occur prior to the performance of any work under the contract by the subcontractor.

23. ARBITRATION: Any references made to arbitration contained in this Contract, Vendor's bid, or in any American Institute of Architects documents pertaining to this Contract are hereby deleted, void, and of no effect.

24. MODIFICATIONS: This writing is the parties' final expression of intent. Notwithstanding anything contained in this Contract to the contrary no modification of this Contract shall be binding without mutual written consent of the Agency, and the Vendor, with approval of the Purchasing Division and the Attorney General's office (Attorney General approval is as to form only). Any change to existing contracts that adds work or changes contract cost, and were not included in the original contract, must be approved by the Purchasing Division and the Attorney General's Office (as to form) prior to the implementation of the change or commencement of work affected by the change.

25. WAIVER: The failure of either party to insist upon a strict performance of any of the terms or provision of this Contract, or to exercise any option, right, or remedy herein contained, shall not be construed as a waiver or a relinquishment for the future of such term, provision, option, right, or remedy, but the same shall continue in full force and effect. Any waiver must be expressly stated in writing and signed by the waiving party.

26. SUBSEQUENT FORMS: The terms and conditions contained in this Contract shall supersede any and all subsequent terms and conditions which may appear on any form documents submitted by Vendor to the Agency or Purchasing Division such as price lists, order forms, invoices, sales agreements, or maintenance agreements, and includes internet websites or other electronic documents. Acceptance or use of Vendor's forms does not constitute acceptance of the terms and conditions contained thereon.

27. ASSIGNMENT: Neither this Contract nor any monies due, or to become due hereunder, may be assigned by the Vendor without the express written consent of the Agency, the Purchasing Division, the Attorney General's office (as to form only), and any other government agency or office that may be required to approve such assignments.

28. WARRANTY: The Vendor expressly warrants that the goods and/or services covered by this Contract will: (a) conform to the specifications, drawings, samples, or other description furnished or specified by the Agency; (b) be merchantable and fit for the purpose intended; and (c) be free from defect in material and workmanship.

29. STATE EMPLOYEES: State employees are not permitted to utilize this Contract for personal use and the Vendor is prohibited from permitting or facilitating the same.

30. PRIVACY, SECURITY, AND CONFIDENTIALITY: The Vendor agrees that it will not disclose to anyone, directly or indirectly, any such personally identifiable information or other confidential information gained from the Agency, unless the individual who is the subject of the information consents to the disclosure in writing or the disclosure is made pursuant to the Agency's policies, procedures, and rules. Vendor further agrees to comply with the Confidentiality Policies and Information Security Accountability Requirements, set forth in <http://www.state.wv.us/admin/purchase/privacy/default.html>.

31. YOUR SUBMISSION IS A PUBLIC DOCUMENT: Vendor's entire response to the Solicitation and the resulting Contract are public documents. As public documents, they will be disclosed to the public following the bid/proposal opening or award of the contract, as required by the competitive bidding laws of West Virginia Code §§ 5A-3-1 et seq., 5-22-1 et seq., and 5G-1-1 et seq. and the Freedom of Information Act West Virginia Code §§ 29B-1-1 et seq.

DO NOT SUBMIT MATERIAL YOU CONSIDER TO BE CONFIDENTIAL, A TRADE SECRET, OR OTHERWISE NOT SUBJECT TO PUBLIC DISCLOSURE.

Submission of any bid, proposal, or other document to the Purchasing Division constitutes your explicit consent to the subsequent public disclosure of the bid, proposal, or document. The Purchasing Division will disclose any document labeled "confidential," "proprietary," "trade secret," "private," or labeled with any other claim against public disclosure of the documents, to include any "trade secrets" as defined by West Virginia Code § 47-22-1 et seq. All submissions are subject to public disclosure without notice.

32. LICENSING: In accordance with West Virginia Code of State Rules § 148-1-6.1.e, Vendor must be licensed and in good standing in accordance with any and all state and local laws and requirements by any state or local agency of West Virginia, including, but not limited to, the West Virginia Secretary of State's Office, the West Virginia Tax Department, West Virginia Insurance Commission, or any other state agency or political subdivision. Obligations related to political subdivisions may include, but are not limited to, business licensing, business and occupation taxes, inspection compliance, permitting, etc. Upon request, the Vendor must provide all necessary releases to obtain information to enable the Purchasing Division Director or the Agency to verify that the Vendor is licensed and in good standing with the above entities.

SUBCONTRACTOR COMPLIANCE: Vendor shall notify all subcontractors providing commodities or services related to this Contract that as subcontractors, they too are required to be licensed, in good standing, and up-to-date on all state and local obligations as described in this section. Obligations related to political subdivisions may include, but are not limited to, business licensing, business and occupation taxes, inspection compliance, permitting, etc. Notification under this provision must occur prior to the performance of any work under the contract by the subcontractor.

33. ANTITRUST: In submitting a bid to, signing a contract with, or accepting a Award Document from any agency of the State of West Virginia, the Vendor agrees to convey, sell, assign, or transfer to the State of West Virginia all rights, title, and interest in and to all causes of action it may now or hereafter acquire under the antitrust laws of the United States and the State of West Virginia for price fixing and/or unreasonable restraints of trade relating to the particular commodities or services purchased or acquired by the State of West Virginia. Such assignment shall be made and become effective at the time the purchasing agency tenders the initial payment to Vendor.

34. VENDOR CERTIFICATIONS: By signing its bid or entering into this Contract, Vendor certifies (1) that its bid or offer was made without prior understanding, agreement, or connection with any corporation, firm, limited liability company, partnership, person or entity submitting a bid or offer for the same material, supplies, equipment or services; (2) that its bid or offer is in all respects fair and without collusion or fraud; (3) that this Contract is accepted or entered into without any prior understanding, agreement, or connection to any other entity that could be considered a violation of law; and (4) that it has reviewed this Solicitation in its entirety; understands the requirements, terms and conditions, and other information contained herein.

Vendor's signature on its bid or offer also affirms that neither it nor its representatives have any interest, nor shall acquire any interest, direct or indirect, which would compromise the performance of its services hereunder. Any such interests shall be promptly presented in detail to the Agency. The individual signing this bid or offer on behalf of Vendor certifies that he or she is authorized by the Vendor to execute this bid or offer or any documents related thereto on Vendor's behalf; that he or she is authorized to bind the Vendor in a contractual relationship; and that, to the best of his or her knowledge, the Vendor has properly registered with any State agency that may require registration.

35. VENDOR RELATIONSHIP: The relationship of the Vendor to the State shall be that of an independent contractor and no principal-agent relationship or employer-employee relationship is contemplated or created by this Contract. The Vendor as an independent contractor is solely liable for the acts and omissions of its employees and agents. Vendor shall be responsible for selecting, supervising, and compensating any and all individuals employed pursuant to the terms of this Solicitation and resulting contract. Neither the Vendor, nor any employees or subcontractors of the Vendor, shall be deemed to be employees of the State for any purpose whatsoever. Vendor shall be exclusively responsible for payment of employees and contractors for all wages and salaries, taxes, withholding payments, penalties, fees, fringe benefits, professional liability insurance premiums, contributions to insurance and pension, or other deferred compensation plans, including but not limited to, Workers' Compensation and Social Security obligations, licensing fees, etc. and the filing of all necessary documents, forms, and returns pertinent to all of the foregoing.

Vendor shall hold harmless the State, and shall provide the State and Agency with a defense against any and all claims including, but not limited to, the foregoing payments, withholdings, contributions, taxes, Social Security taxes, and employer income tax returns.

36. INDEMNIFICATION: The Vendor agrees to indemnify, defend, and hold harmless the State and the Agency, their officers, and employees from and against: (1) Any claims or losses for services rendered by any subcontractor, person, or firm performing or supplying services, materials, or supplies in connection with the performance of the Contract; (2) Any claims or losses resulting to any person or entity injured or damaged by the Vendor, its officers, employees, or subcontractors by the publication, translation, reproduction, delivery, performance, use, or disposition of any data used under the Contract in a manner not authorized by the Contract, or by Federal or State statutes or regulations; and (3) Any failure of the Vendor, its officers, employees, or subcontractors to observe State and Federal laws including, but not limited to, labor and wage and hour laws.

37. PURCHASING AFFIDAVIT: In accordance with West Virginia Code §§ 5A-3-10a and 5-22-1(i), the State is prohibited from awarding a contract to any bidder that owes a debt to the State or a political subdivision of the State, Vendors are required to sign, notarize, and submit the Purchasing Affidavit to the Purchasing Division affirming under oath that it is not in default on any monetary obligation owed to the state or a political subdivision of the state.

38. CONFLICT OF INTEREST: Vendor, its officers or members or employees, shall not presently have or acquire an interest, direct or indirect, which would conflict with or compromise the performance of its obligations hereunder. Vendor shall periodically inquire of its officers, members and employees to ensure that a conflict of interest does not arise. Any conflict of interest discovered shall be promptly presented in detail to the Agency.

39. REPORTS: Vendor shall provide the Agency and/or the Purchasing Division with the following reports identified by a checked box below:

Such reports as the Agency and/or the Purchasing Division may request. Requested reports may include, but are not limited to, quantities purchased, agencies utilizing the contract, total contract expenditures by agency, etc.

Quarterly reports detailing the total quantity of purchases in units and dollars, along with a listing of purchases by agency. Quarterly reports should be delivered to the Purchasing Division via email at purchasing.division@wv.gov.

40. BACKGROUND CHECK: In accordance with W. Va. Code § 15-2D-3, the State reserves the right to prohibit a service provider's employees from accessing sensitive or critical information or to be present at the Capitol complex based upon results addressed from a criminal background check. Service providers should contact the West Virginia Division of Protective Services by phone at (304) 558-9911 for more information.

41. PREFERENCE FOR USE OF DOMESTIC STEEL PRODUCTS: Except when authorized by the Director of the Purchasing Division pursuant to W. Va. Code § 5A-3-56, no contractor may use or supply steel products for a State Contract Project other than those steel products made in the United States. A contractor who uses steel products in violation of this section may be subject to civil penalties pursuant to W. Va. Code § 5A-3-56. As used in this section:

- a. "State Contract Project" means any erection or construction of, or any addition to, alteration of or other improvement to any building or structure, including, but not limited to, roads or highways, or the installation of any heating or cooling or ventilating plants or other equipment, or the supply of and materials for such projects, pursuant to a contract with the State of West Virginia for which bids were solicited on or after June 6, 2001.
- b. "Steel Products" means products rolled, formed, shaped, drawn, extruded, forged, cast, fabricated or otherwise similarly processed, or processed by a combination of two or more or such operations, from steel made by the open heath, basic oxygen, electric furnace, Bessemer or other steel making process.
- c. The Purchasing Division Director may, in writing, authorize the use of foreign steel products if:

1. The cost for each contract item used does not exceed one tenth of one percent (.1%) of the total contract cost or two thousand five hundred dollars (\$2,500.00), whichever is greater. For the purposes of this section, the cost is the value of the steel product as delivered to the project; or
2. The Director of the Purchasing Division determines that specified steel materials are not produced in the United States in sufficient quantity or otherwise are not reasonably available to meet contract requirements.

42. PREFERENCE FOR USE OF DOMESTIC ALUMINUM, GLASS, AND STEEL: In Accordance with W. Va. Code § 5-19-1 et seq., and W. Va. CSR § 148-10-1 et seq., for every contract or subcontract, subject to the limitations contained herein, for the construction, reconstruction, alteration, repair, improvement or maintenance of public works or for the purchase of any item of machinery or equipment to be used at sites of public works, only domestic aluminum, glass or steel products shall be supplied unless the spending officer determines, in writing, after the receipt of offers or bids, (1) that the cost of domestic aluminum, glass or steel products is unreasonable or inconsistent with the public interest of the State of West Virginia, (2) that domestic aluminum, glass or steel products are not produced in sufficient quantities to meet the contract requirements, or (3) the available domestic aluminum, glass, or steel do not meet the contract specifications. This provision only applies to public works contracts awarded in an amount more than fifty thousand dollars (\$50,000) or public works contracts that require more than ten thousand pounds of steel products.

The cost of domestic aluminum, glass, or steel products may be unreasonable if the cost is more than twenty percent (20%) of the bid or offered price for foreign made aluminum, glass, or steel products. If the domestic aluminum, glass or steel products to be supplied or produced in a "substantial labor surplus area", as defined by the United States Department of Labor, the cost of domestic aluminum, glass, or steel products may be unreasonable if the cost is more than thirty percent (30%) of the bid or offered price for foreign made aluminum, glass, or steel products. This preference shall be applied to an item of machinery or equipment, as indicated above, when the item is a single unit of equipment or machinery manufactured primarily of aluminum, glass or steel, is part of a public works contract and has the sole purpose or of being a permanent part of a single public works project. This provision does not apply to equipment or machinery purchased by a spending unit for use by that spending unit and not as part of a single public works project.

All bids and offers including domestic aluminum, glass or steel products that exceed bid or offer prices including foreign aluminum, glass or steel products after application of the preferences provided in this provision may be reduced to a price equal to or lower than the lowest bid or offer price for foreign aluminum, glass or steel products plus the applicable preference. If the reduced bid or offer prices are made in writing and supersede the prior bid or offer prices, all bids or offers, including the reduced bid or offer prices, will be reevaluated in accordance with this rule.

43. INTERESTED PARTY SUPPLEMENTAL DISCLOSURE: W. Va. Code § 6D-1-2 requires that for contracts with an actual or estimated value of at least \$1 million, the vendor must submit to the Agency a supplemental disclosure of interested parties reflecting any new or differing interested parties to the contract, which were not included in the original pre-award interested party disclosure, within 30 days following the completion or termination of the contract. A copy of that form is included with this solicitation or can be obtained from the WV Ethics Commission. This requirement does not apply to publicly traded companies listed on a national or international stock exchange. A more detailed definition of interested parties can be obtained from the form referenced above.

44. PROHIBITION AGAINST USED OR REFURBISHED: Unless expressly permitted in the solicitation published by the State, Vendor must provide new, unused commodities, and is prohibited from supplying used or refurbished commodities, in fulfilling its responsibilities under this Contract.

45. VOID CONTRACT CLAUSES – This Contract is subject to the provisions of West Virginia Code § 5A-3-62, which automatically voids certain contract clauses that violate State law.

ADDITIONAL TERMS AND CONDITIONS (Construction Contracts Only)

1. CONTRACTOR'S LICENSE: Until June 15, 2021, West Virginia Code § 21-11-2, and after that date, § 30-42-2, requires that all persons desiring to perform contracting work in this state be licensed. The West Virginia Contractors Licensing Board is empowered to issue the contractor's license. Applications for a contractor's license may be made by contacting the West Virginia Contractor Licensing Board.

The apparent successful Vendor must furnish a copy of its contractor's license prior to the issuance of a contract award document.

2. DRUG-FREE WORKPLACE AFFIDAVIT: W. Va. Code § 21-1D-5 provides that any solicitation for a public improvement contract requires each Vendor that submits a bid for the work to submit an affidavit that the Vendor has a written plan for a drug-free workplace policy. If the affidavit is not submitted with the bid submission, the Purchasing Division shall promptly request by telephone and electronic mail that the low bidder and second low bidder provide the affidavit within one business day of the request. Failure to submit the affidavit within one business day of receiving the request shall result in disqualification of the bid. To comply with this law, Vendor should complete the enclosed drug-free workplace affidavit and submit the same with its bid. Failure to submit the signed and notarized drugfree workplace affidavit or a similar affidavit that fully complies with the requirements of the applicable code, within one business day of being requested to do so shall result in disqualification of Vendor's bid. Pursuant to W. Va. Code 21-1D-2(b) and (k), this provision does not apply to public improvement contracts the value of which is \$100,000 or less or temporary or emergency repairs.

2.1. DRUG-FREE WORKPLACE POLICY: Pursuant to W. Va. Code § 21-1D-4, Vendor and its subcontractors must implement and maintain a written drug-free workplace policy that complies with said article. The awarding public authority shall cancel this contract if: (1) Vendor fails to implement and maintain a written drug-free workplace policy described in the preceding paragraph, (2) Vendor fails to provide information regarding implementation of its drug-free workplace policy at the request of the public authority; or (3) Vendor provides to the public authority false information regarding the contractor's drug-free workplace policy.

Pursuant to W. Va. Code 21-1D-2(b) and (k), this provision does not apply to public improvement contracts the value of which is \$100,000 or less or temporary or emergency repairs.

3. DRUG FREE WORKPLACE REPORT: Pursuant to W. Va. Code § 21-1D-7b, no less than once per year, or upon completion of the project, every contractor shall provide a certified report to the public authority which let the contract. For contracts over \$25,000, the public authority shall be the West Virginia Purchasing Division. For contracts of \$25,000 or less, the public authority shall be the agency issuing the contract. The report shall include:

(1) Information to show that the education and training service to the requirements of West Virginia Code § 21-1D-5 was provided;

(2) The name of the laboratory certified by the United States Department of Health and Human Services or its successor that performs the drug tests;

(3) The average number of employees in connection with the construction on the public improvement;

(4) Drug test results for the following categories including the number of positive tests and the number of negative tests: (A) Pre-employment and new hires; (B) Reasonable suspicion; (C) Post-accident; and (D) Random.

Vendor should utilize the attached Certified Drug Free Workplace Report Coversheet when submitting the report required hereunder. Pursuant to W. Va. Code 21-1D-2(b) and (k), this provision does not apply to public improvement contracts the value of which is \$100,000 or less or temporary or emergency repairs.

4. AIA DOCUMENTS: All construction contracts that will be completed in conjunction with architectural services procured under Chapter 5G of the West Virginia Code will be governed by the attached AIA documents, as amended by the Supplementary Conditions for the State of West Virginia, in addition to the terms and conditions contained herein.

4A. PROHIBITION AGAINST GENERAL CONDITIONS: Notwithstanding anything contained in the AIA Documents or the Supplementary Conditions, the State of West Virginia will not pay for general conditions, or winter conditions, or any other condition representing a delay in the contracts. The Vendor is expected to mitigate delay costs to the greatest extent possible and any costs associated with Delays must be specifically and concretely identified. The state will not consider an average daily rate multiplied by the number of days extended to be an acceptable charge.

5. GREEN BUILDINGS MINIMUM ENERGY STANDARDS: In accordance with § 22-29-4, all new building construction projects of public agencies that have not entered the schematic design phase prior to July 1, 2012, or any building construction project receiving state grant funds and appropriations, including public schools, that have not entered the schematic design phase prior to July 1, 2012, shall be designed and constructed complying with the ICC International Energy Conservation Code, adopted by the State Fire Commission, and the ANSI/ASHRAE/IESNA Standard 90.1-2007: Provided, That if any construction project has a commitment of federal funds to pay for a portion of such project, this provision shall only apply to the extent such standards are consistent with the federal standards.

6. LOCAL LABOR MARKET HIRING REQUIREMENT: Pursuant to West Virginia Code §21-1C-1 et seq., Employers shall hire at least seventy-five percent of employees for public improvement construction projects from the local labor market, to be rounded off, with at least two employees from outside the local labor market permissible for each employer per project.

Any employer unable to employ the minimum number of employees from the local labor market shall inform the nearest office of Workforce West Virginia of the number of qualified employees needed and provide a job description of the positions to be filled.

If, within three business days following the placing of a job order, Workforce West Virginia is unable to refer any qualified job applicants to the employer or refers less qualified job applicants than the number requested, then Workforce West Virginia shall issue a waiver to the employer stating the unavailability of applicant and shall permit the employer to fill any positions covered by

the waiver from outside the local labor market. The waiver shall be in writing and shall be issued within the prescribed three days. A waiver certificate shall be sent to both the employer for its permanent project records and to the public authority.

Any employer who violates this requirement is subject to a civil penalty of \$250 per each employee less than the required threshold of seventy-five percent per day of violation after receipt of a notice of violation.

Any employer that continues to violate any provision of this article more than fourteen calendar days after receipt of a notice of violation is subject to a civil penalty of \$500 per each employee less than the required threshold of seventy-five percent per day of violation.

The following terms used in this section have the meaning shown below.

(1) The term “construction project” means any construction, reconstruction, improvement, enlargement, painting, decorating or repair of any public improvement let to contract in an amount equal to or greater than \$500,000. The term “construction project” does not include temporary or emergency repairs;

(2) The term “employee” means any person hired or permitted to perform hourly work for wages by a person, firm or corporation in the construction industry; The term “employee” does not include:(i) Bona fide employees of a public authority or individuals engaged in making temporary or emergency repairs;(ii) Bona fide independent contractors; or(iii) Salaried supervisory personnel necessary to assure efficient execution of the employee's work;

(3) The term “employer” means any person, firm or corporation employing one or more employees on any public improvement and includes all contractors and subcontractors;

(4) The term “local labor market” means every county in West Virginia and any county outside of West Virginia if any portion of that county is within fifty miles of the border of West Virginia;

(5) The term “public improvement” includes the construction of all buildings, roads, highways, bridges, streets, alleys, sewers, ditches, sewage disposal plants, waterworks, airports and all other structures that may be let to contract by a public authority, excluding improvements funded, in whole or in part, by federal funds.

7. DAVIS-BACON AND RELATED ACT WAGE RATES:

- The work performed under this contract is federally funded in whole, or in part. Pursuant to _____, Vendors are required to pay applicable Davis-Bacon wage rates.
- The work performed under this contract is not subject to Davis-Bacon wage rates.

8. SUBCONTRACTOR LIST SUBMISSION: In accordance with W. Va. Code § 5-22-1, the apparent low bidder on a contract valued at more than \$250,000.00 for the construction, alteration, decoration, painting or improvement of a new or existing building or structure shall submit a list of all subcontractors who will perform more than \$25,000.00 of work on the project including labor and materials. (This section does not apply to any other construction projects, such as highway, mine reclamation, water or sewer projects.) The subcontractor list shall be provided to the Purchasing Division within one business day of the opening of bids for review. If the apparent low bidder fails to submit the subcontractor list, the Purchasing Division shall promptly request by telephone and electronic mail that the low bidder and second low bidder provide the subcontractor list within one business day of the request. Failure to submit the subcontractor list within one business day of receiving the request shall result in disqualification of the bid.

If no subcontractors who will perform more than \$25,000.00 of work are to be used to complete the project, the apparent low bidder must make this clear on the subcontractor list, in the bid itself, or in response to the Purchasing Division's request for the subcontractor list.

a. Required Information. The subcontractor list must contain the following information:

- i. Bidder's name
- ii. Name of each subcontractor performing more than \$25,000 of work on the project.
- iii. The license number of each subcontractor, as required by W. Va. Code § 21-11-1 et. seq.
- iv. If applicable, a notation that no subcontractor will be used to perform more than \$25,000.00 of work. (This item iv. is not required if the vendor makes this clear in the bid itself or in documentation following the request for the subcontractor list.)

b. Subcontractor List Submission Form: The subcontractor list may be submitted in any form, including the attached form, as long as the required information noted above is included. If any information is missing from the bidder's subcontractor list submission, it may be obtained from other documents such as bids, emails, letters, etc. that accompany the subcontractor list submission.

c. Substitution of Subcontractor. Written approval must be obtained from the State Spending Unit before any subcontractor substitution is permitted. Substitutions are not permitted unless:

- i. The subcontractor listed in the original bid has filed for bankruptcy;
- ii. The subcontractor in the original bid has been debarred or suspended; or
- iii. The contractor certifies in writing that the subcontractor listed in the original bid fails, is unable, or refuses to perform his subcontract.

ADDITIONAL TERMS AND CONDITIONS
(Architectural and Engineering Contracts Only)

1. PLAN AND DRAWING DISTRIBUTION: All plans and drawings must be completed and available for distribution at least five business days prior to a scheduled pre-bid meeting for the construction or other work related to the plans and drawings.

2. PROJECT ADDENDA REQUIREMENTS: The Architect/Engineer and/or Agency shall be required to abide by the following schedule in issuing construction project addenda. The Architect/Engineer shall prepare any addendum materials for which it is responsible, and a list of all vendors that have obtained drawings and specifications for the project. The Architect/Engineer shall then send a copy of the addendum materials and the list of vendors to the State Agency for which the contract is issued to allow the Agency to make any necessary modifications. The addendum and list shall then be forwarded to the Purchasing Division buyer by the Agency. The Purchasing Division buyer shall send the addendum to all interested vendors and, if necessary, extend the bid opening date. Any addendum should be received by the Purchasing Division at least fourteen (14) days prior to the bid opening date.

3. PRE-BID MEETING RESPONSIBILITIES: The Architect/Engineer shall be available to attend any pre-bid meeting for the construction or other work resulting from the plans, drawings, or specifications prepared by the Architect/Engineer.

4. AIA DOCUMENTS: All construction contracts that will be completed in conjunction with architectural services procured under Chapter 5G of the West Virginia Code will be governed by the attached AIA documents, as amended by the Supplementary Conditions for the State of West Virginia, in addition to the terms and conditions contained herein. The terms and conditions of this document shall prevail over anything contained in the AIA Documents or the Supplementary Conditions.

5. GREEN BUILDINGS MINIMUM ENERGY STANDARDS: In accordance with West Virginia Code § 22-29-4, all new building construction projects of public agencies that have not entered the schematic design phase prior to July 1, 2012, or any building construction project receiving state grant funds and appropriations, including public schools, that have not entered the schematic design phase prior to July 1, 2012, shall be designed and constructed complying with the ICC International Energy Conservation Code, adopted by the State Fire Commission, and the ANSI/ASHRAE/IESNA Standard 90.1-2007: Provided, That if any construction project has a commitment of federal funds to pay for a portion of such project, this provision shall only apply to the extent such standards are consistent with the federal standards.

DESIGNATED CONTACT: Vendor appoints the individual identified in this Section as the Contract Administrator and the initial point of contact for matters relating to this Contract.

Nathaniel G. Rohrig President
(Name, Title)
Nathaniel G. Rohrig President
(Printed Name and Title)
P.O. Box 727 Bridgeport, WV 26330
(Address)
(304) 623-4827 (304) 622-5546
(Phone Number) / (Fax Number)
N.Rohrig@aol.com
(email address)

CERTIFICATION AND SIGNATURE: By signing below, or submitting documentation through wvOASIS, I certify that: I have reviewed this Solicitation in its entirety; that I understand the requirements, terms and conditions, and other information contained herein; that this bid, offer or proposal constitutes an offer to the State that cannot be unilaterally withdrawn; that the product or service proposed meets the mandatory requirements contained in the Solicitation for that product or service, unless otherwise stated herein; that the Vendor accepts the terms and conditions contained in the Solicitation, unless otherwise stated herein; that I am submitting this bid, offer or proposal for review and consideration; that I am authorized by the vendor to execute and submit this bid, offer, or proposal, or any documents related thereto on vendor's behalf; that I am authorized to bind the vendor in a contractual relationship; and that to the best of my knowledge, the vendor has properly registered with any State agency that may require registration.

By signing below, I further certify that I understand this Contract is subject to the provisions of West Virginia Code § 5A-3-62, which automatically voids certain contract clauses that violate State law.

RFT Enterprises, Inc.
(Company)
Nathaniel G. Rohrig President
(Authorized Signature) (Representative Name, Title)
Nathaniel G. Rohrig, President
(Printed Name and Title of Authorized Representative)
8-13-21
(Date)
(304) 623-4827 (304) 622-5546
(Phone Number) (Fax Number)

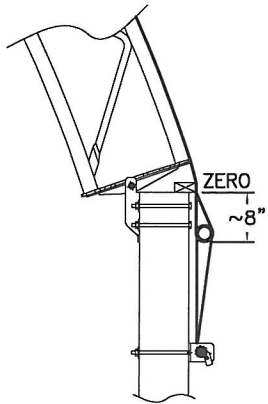

**INCLUSIVE
POCKET**

(220 fabric - std 8" drop below zero)

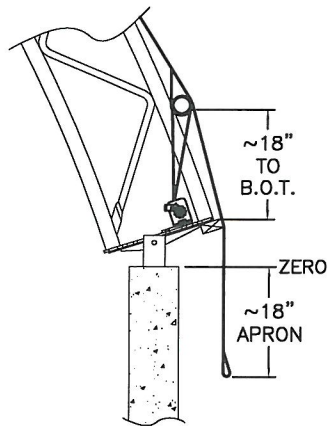

**INTERIOR
TENSION POCKET**

(320 fabric - std 18" drop below zero)

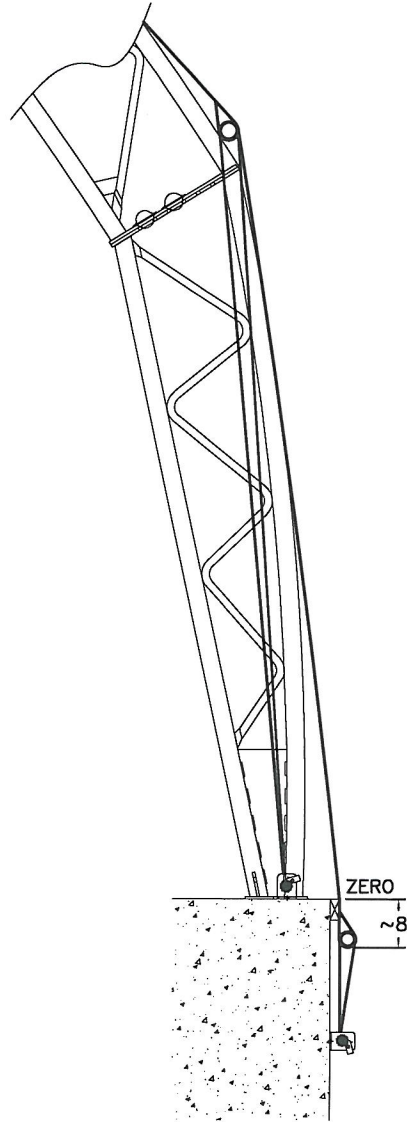

**UPPER INTERIOR
TENSION POCKET
w/ INCLUSIVE
POCKET**

(420 fabric - std 8" drop
below zero)

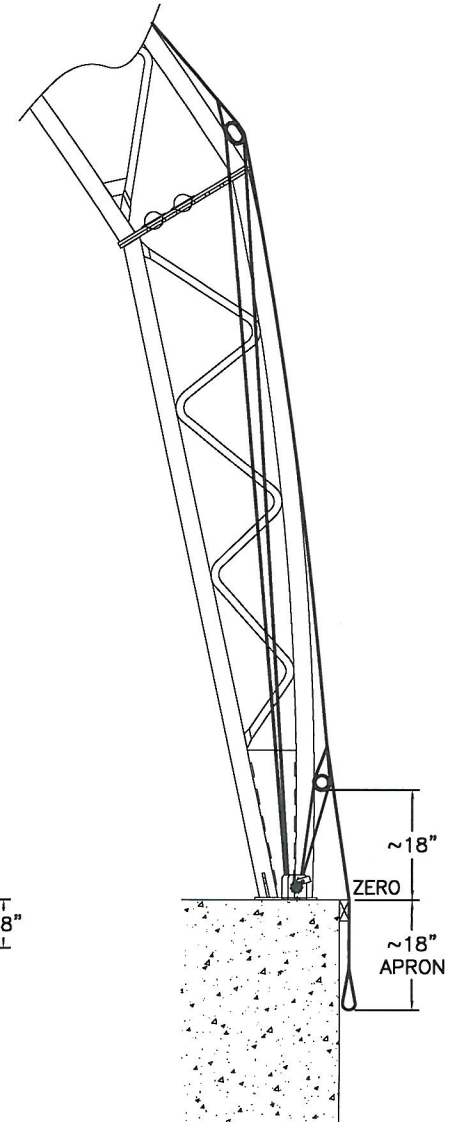

**DUAL INTERIOR
TENSION POCKETS**

(420 fabric - std 18" drop
below zero)

CONTRACTOR LICENSE

Authorized by the

West Virginia Contractor Licensing Board

Number: WV033149

Classification:

SPECIALTY

R & T ENTERPRISES INC
DBA R & T ENTERPRISES INC
PO BOX 727
BRIDGEPORT, WV 26330

Date Issued

Expiration Date

DECEMBER 07, 2020

DECEMBER 07, 2021

Authorized Company Signature

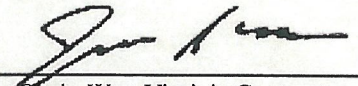
Chair, West Virginia Contractor
Licensing Board

This license, or a copy thereof, must be posted in a conspicuous place at every construction site where work is being performed. This license number must appear in all advertisements, on all bid submissions and on all fully executed and binding contracts. This license cannot be assigned or transferred by licensee. Issued under provisions of West Virginia Code, Chapter 21, Article 11.

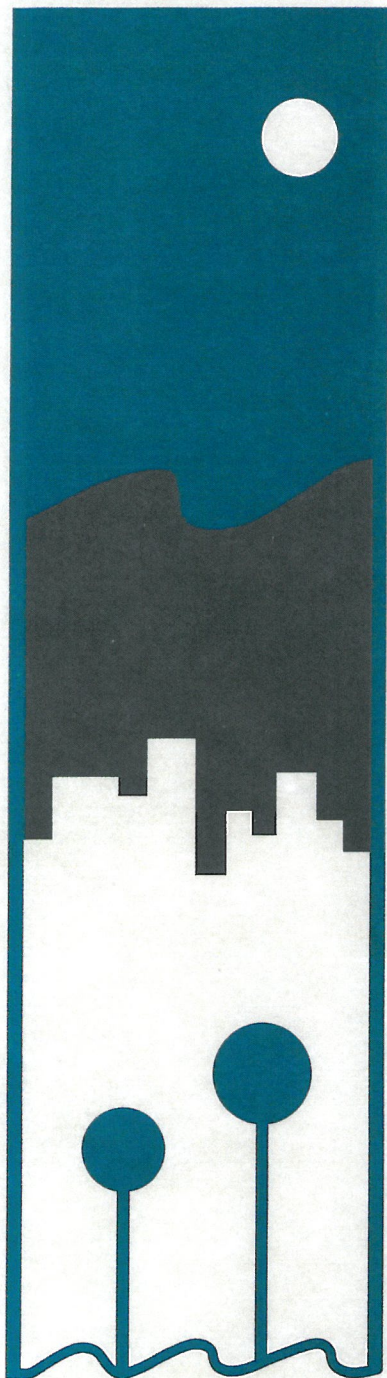

WEST VIRGINIA
CONTRACTOR
LICENSING
BOARD

SYNERGY NON-FR FABRIC

RU88X-6 400 (IPG)



Strength & Durability

Synergy Non-FR Fabric is a heavy weight fabric with 4 mil coatings used for applications requiring minimally flame retardant material with ultraviolet stability. The scrim, which is the woven part of the material, is constructed of individual tapes. The unique composition of the tapes and how they are woven together gives Synergy Non-FR Fabric its tremendous rip, tear and puncture strength. The specialized 4 mil coatings are more resistant to abrasion damage during fabrication and installation of the fabric cover. Synergy Non-FR Fabric comes with a 20 year pro-rata warranty.

Safe & Environmentally Friendly

No toxic chemicals are used in the production of Synergy Non-FR Fabric. All scraps and used covers are 100% recyclable.

Bright Atmosphere

Synergy Non-FR Fabric covers provides an exceptionally bright and pleasant interior atmosphere. Natural light penetrates the fabric while the unique composition of the tapes ensures the cover remains pliable and resistant to ultraviolet damage. The Synergy Non-FR Fabric reduces the conduction of heat and cold, ensuring a building is warmer in the winter and cooler in the summer. The fabric is available in a variety of attractive colours all featuring a bright white underside that further enhances the interior brightness.

Patented double stack weave provides unmatched strength to weight ratios.

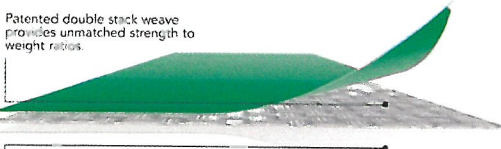

All covers feature a bright white underside that allows for maximum interior light.

Non-FR Fabric Specifications

Weave:	16 x 16 tapes/in (63 tapes/10 cm)	
Coating	4.0 mils average each side (95g/m ²)	
Thickness:		
Coating	Modified LDPE coating with UV protection	
Composition:		
Weight:	12 oz/yd ² (407 g/m ²) +/- 5%	
Thickness:	23 mils (0.59mm)	ASTM D1777
Grab Tensile:	Warp: 370lbs. (1664 N)	ASTM D5034
	Weft: 345 lbs. (1532 N)	ASTM D5034
Strip Tensile: (N/5cm)	Warp: 245 lbs. (2178 N)	ASTM D4851
	Weft: 235 lbs. (2086 N)	ASTM D4851
Tongue Tear:	Warp: 110 lbs. (488 N)	ASTM D2261
	Weft: 100 lbs. (444 N)	ASTM D2261
Trapezoidal Tear:	Warp: 95 lbs. (422 N)	ASTM D4533
	Weft: 90 lbs. (400 N)	ASTM D4533
Mullen Burst:	655 psi (4512 kPa)	ASTM D3786
Cold Crack:	Minus 60° C	ASTM D2136

Non-FR Fabric Fire Ratings

Test / Standard	Flame Spread	Smoke Developed	Char Length
ASTM E-84 (pass)	10	65	----

SYNERGY NON-FR FABRIC

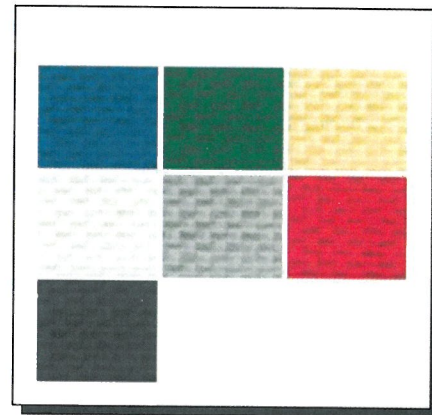

Colors may not be exact as shown here. Contact your local BRITESPAN Dealer for actual fabric samples.

Britespan Building Systems Inc.



CONCRETE PIERS

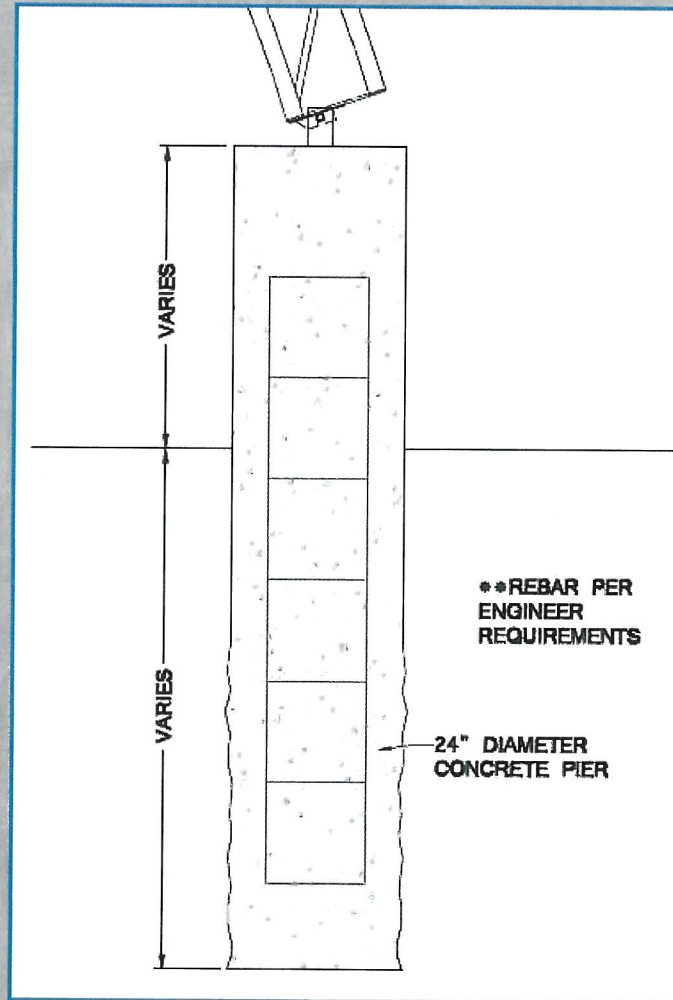
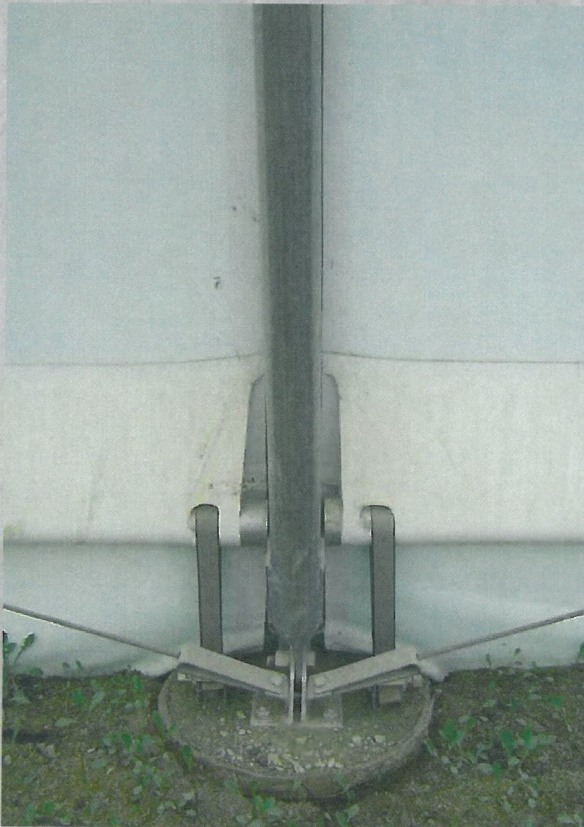

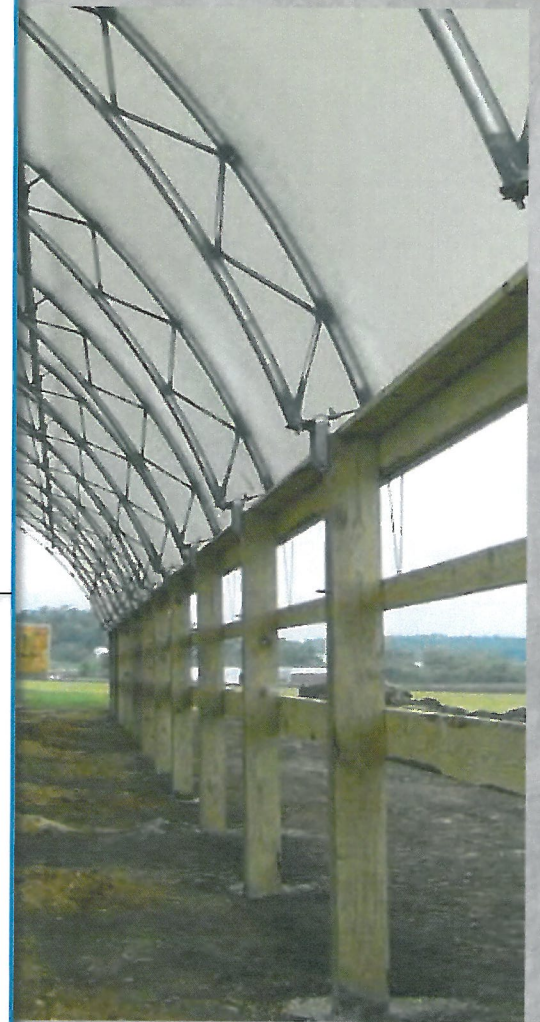
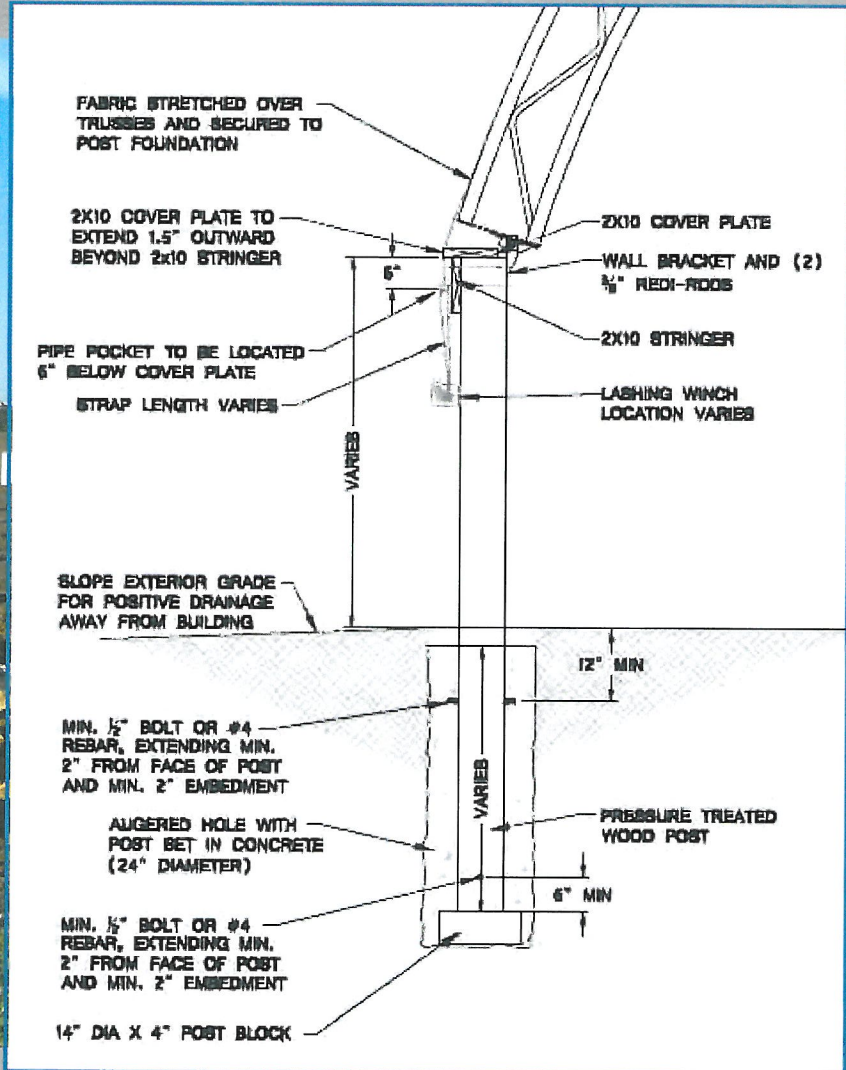

POURED WALL

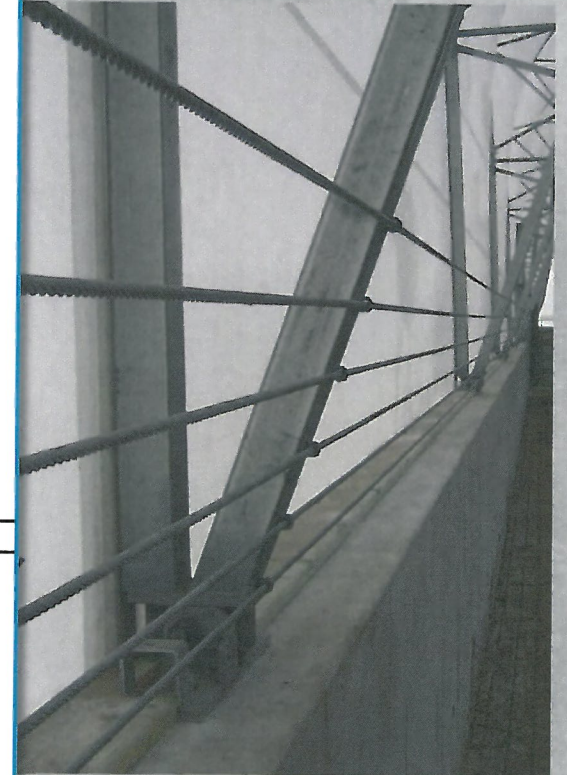
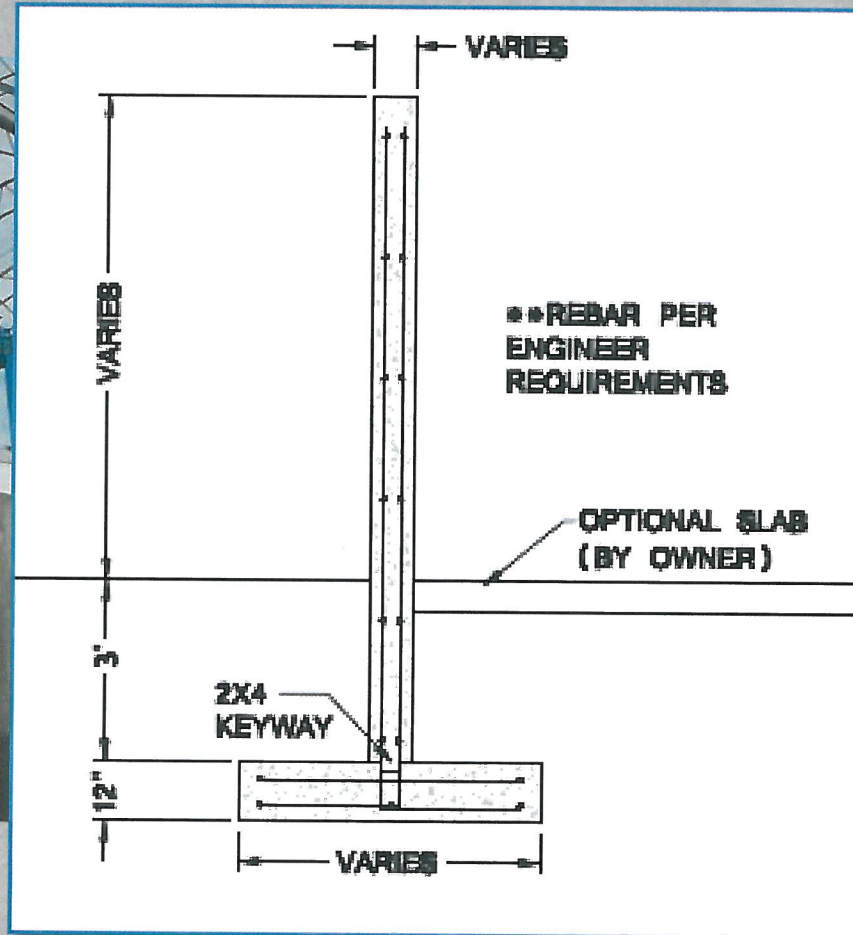
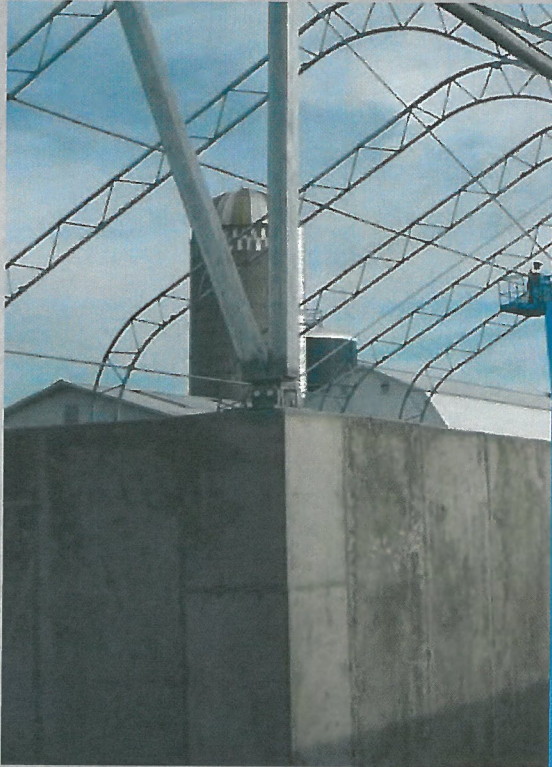

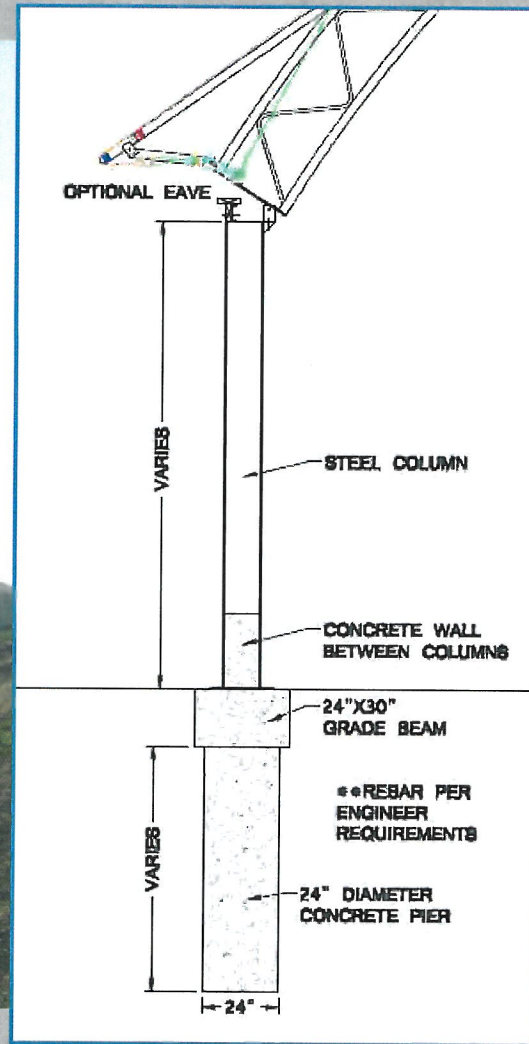

BRITESPAN[™]
BUILDING SYSTEMS INC

STEEL I-BEAMS

MEGA BLOCKS

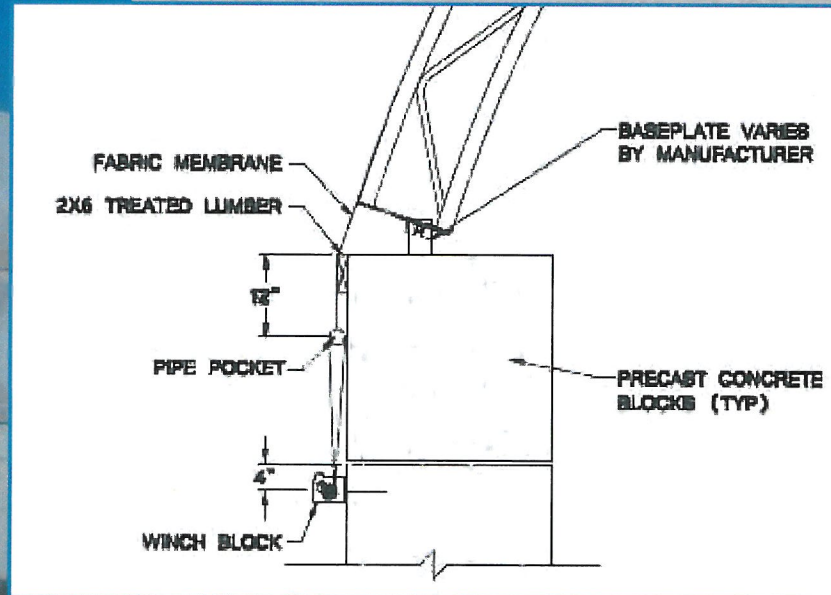
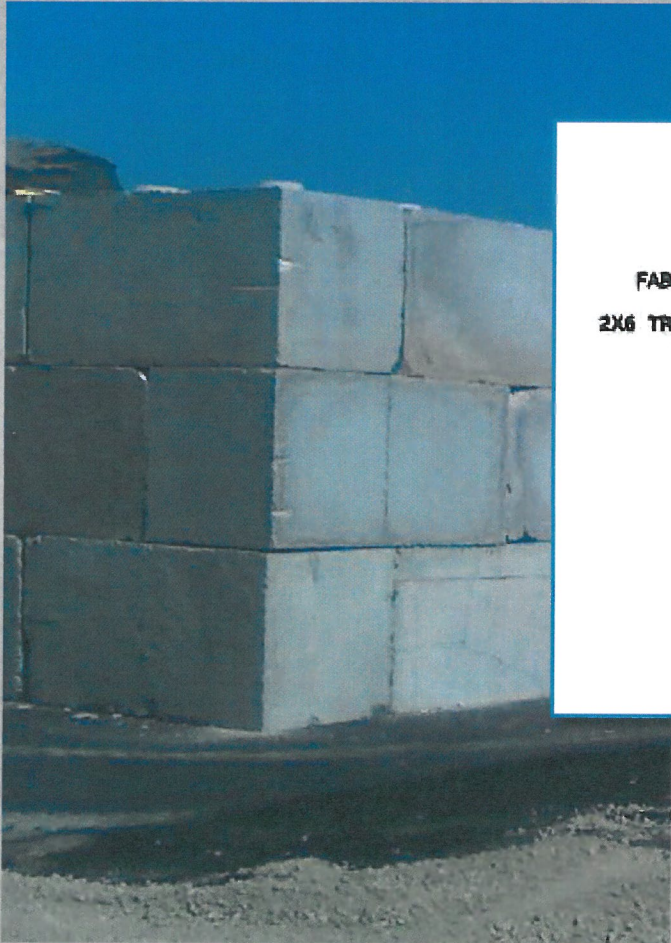

ENGINEERED T-PANEL

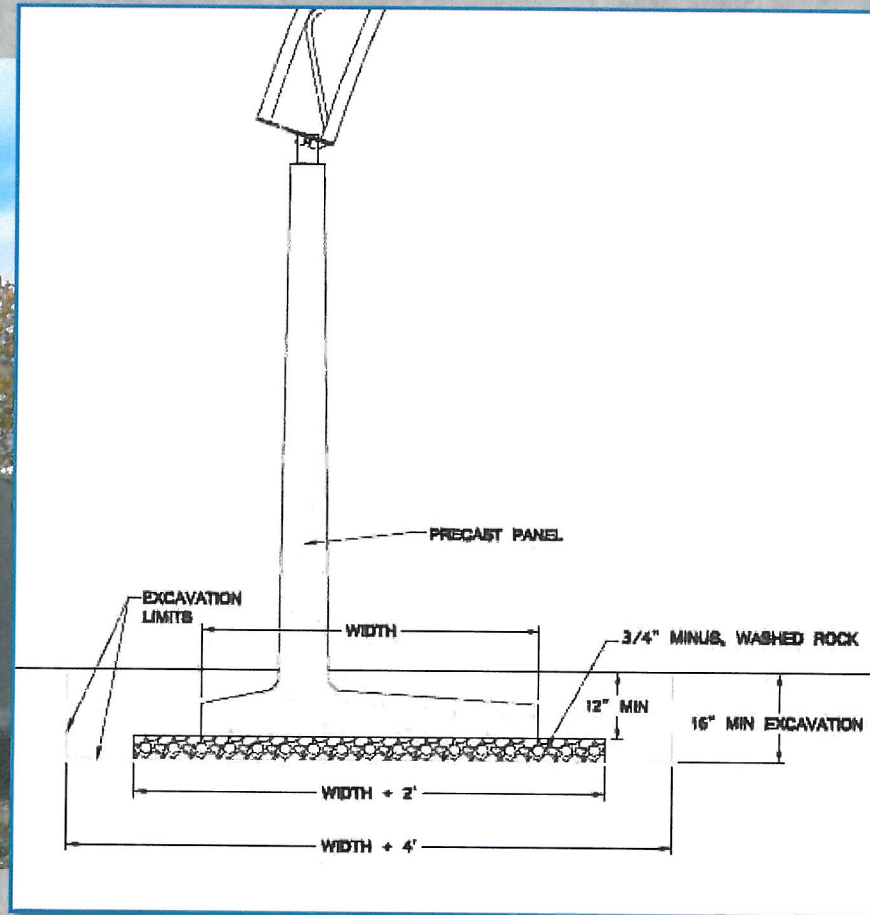

SHIPPING CONTAINERS

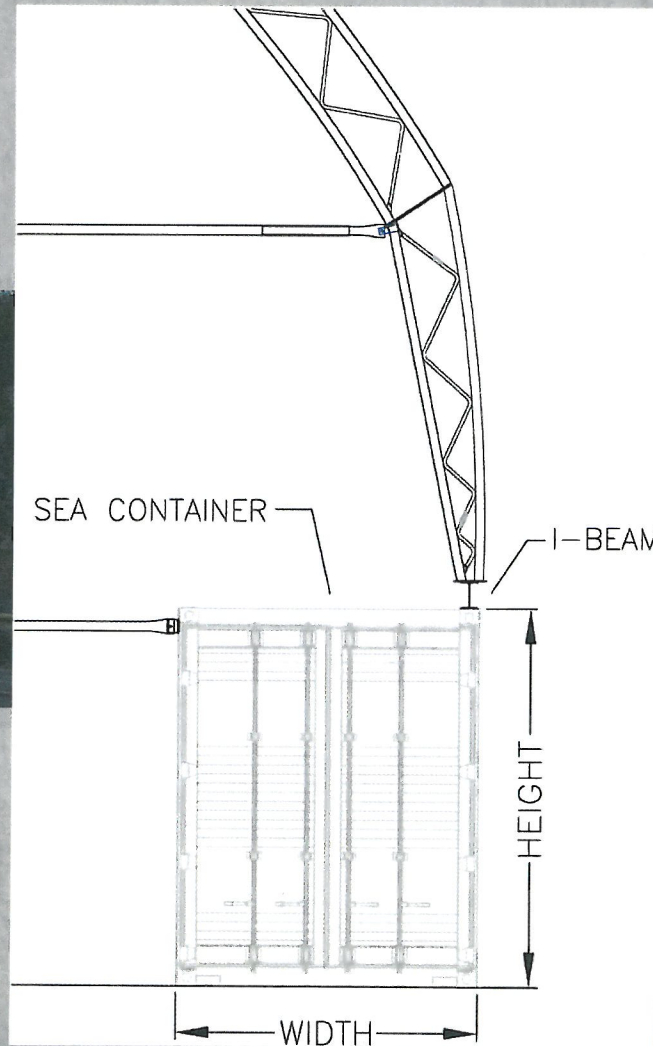

BASE RAIL SYSTEM

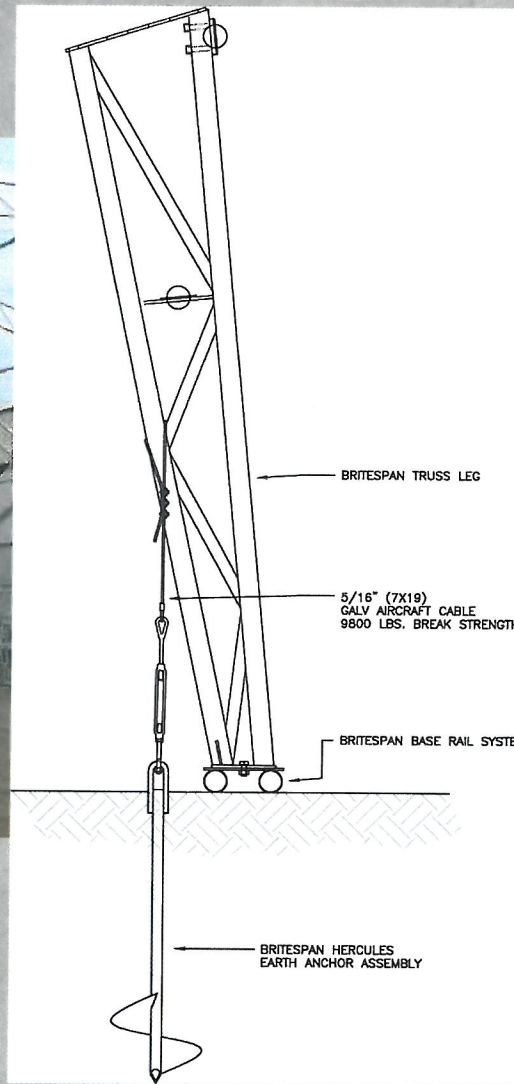

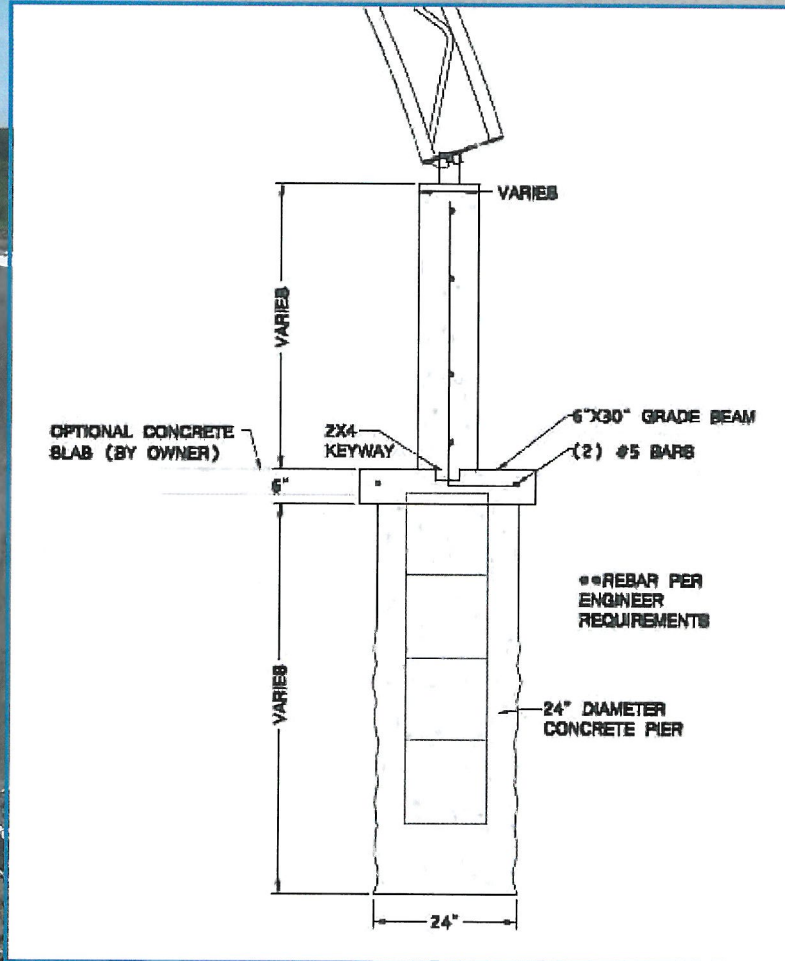

PIER/GRADE BEAM

FLOATING SLAB

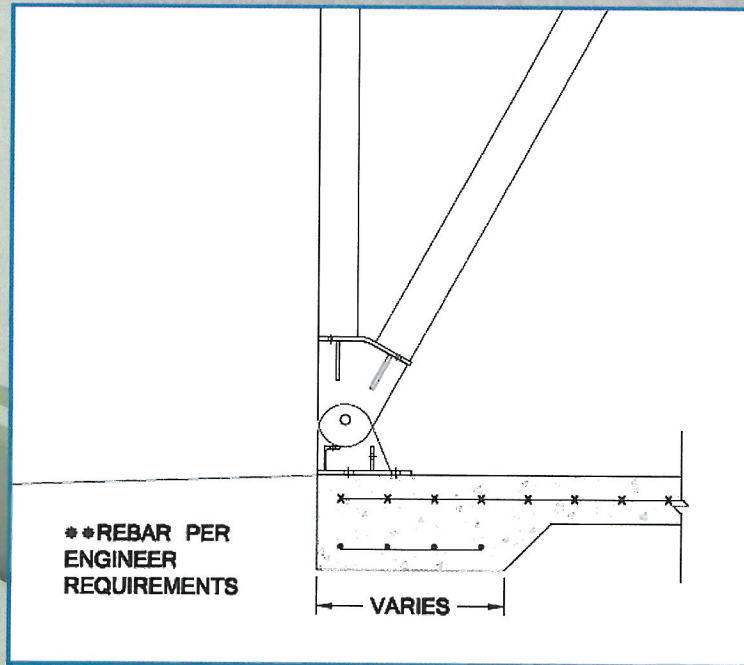
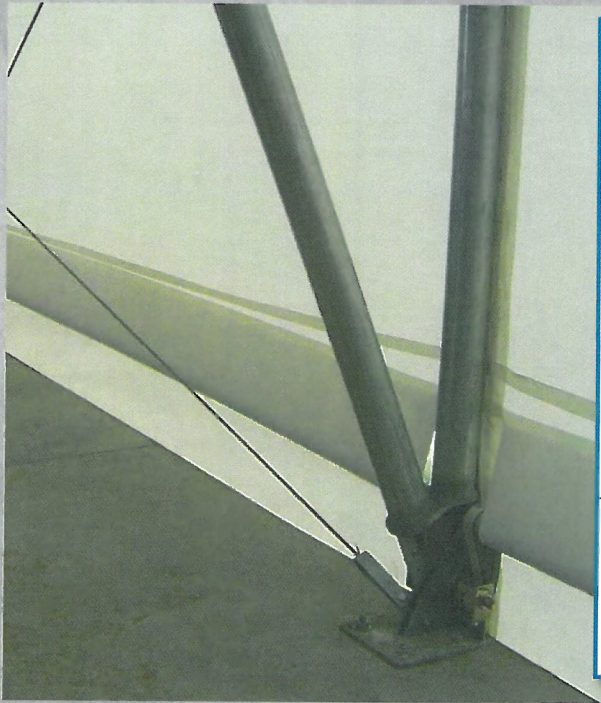

COVER TYPES

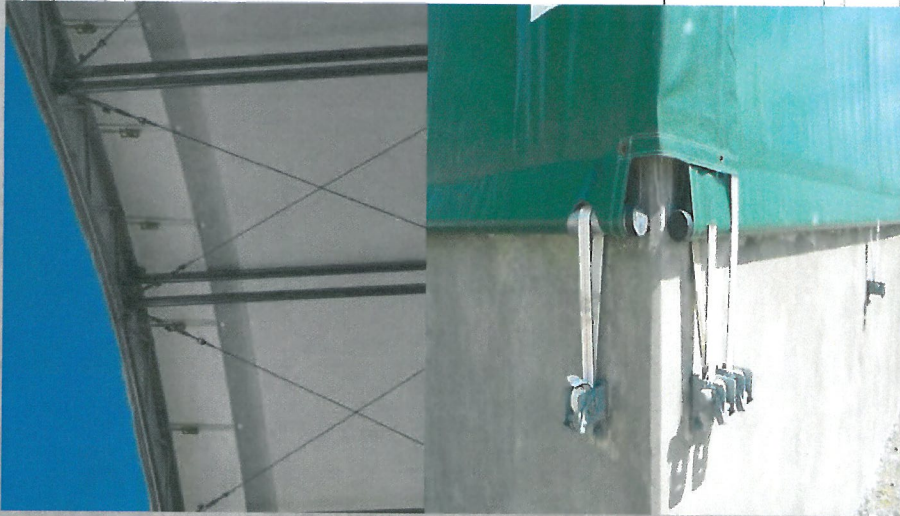
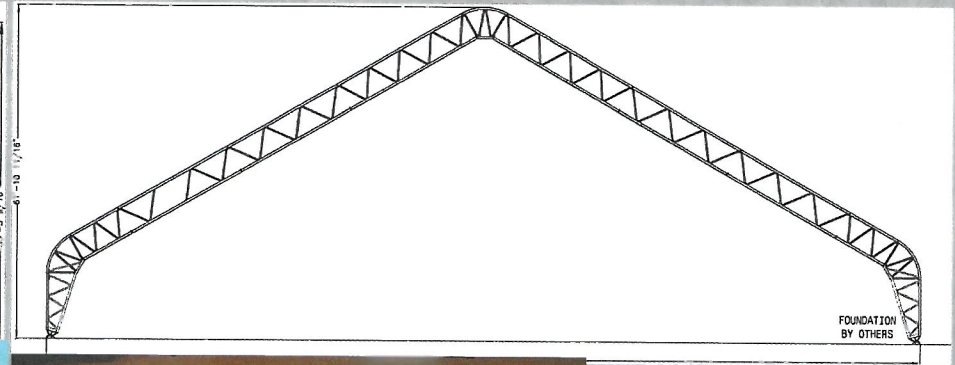
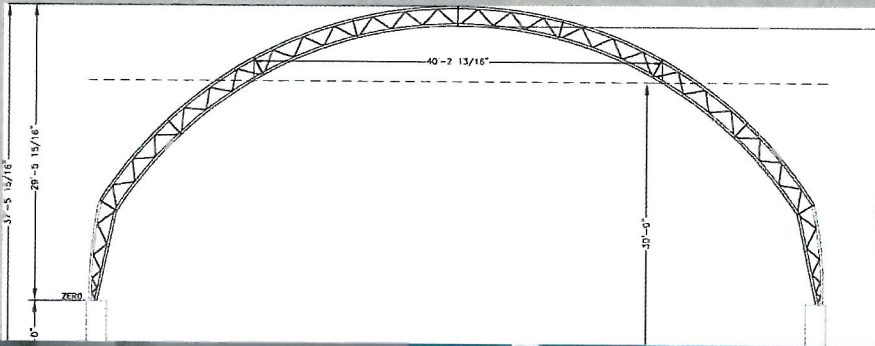

INSURABILITY

DON'T LET A COMPANY SELL YOU A BUILDING THAT DOES NOT COMPLY WITH THE BUILDING CODE JUST BECAUSE YOUR SITUATION DOES NOT MANDATE IT. MANY INSURANCE COMPANIES WILL SELL YOU A POLICY AND COLLECT YOUR PREMIUMS. THEN, WHEN THERE IS A CLAIM, THEY WILL REFUSE TO PAY IT IF THE BUILDING DOES NOT COMPLY WITH THE BUILDING CODE.

LIABILITY

YOU HAVE WORKED HARD FOR EVERYTHING YOU HAVE. WHY LOSE IT IF SOMETHING CATASTROPHIC HAPPENS AND SOMEBODY IS INJURED OR KILLED. WOULD THAT BE WORTH THE FEW DOLLARS YOU MAY HAVE SAVED UP FRONT? JUST BECAUSE YOU DO NOT NEED TO BUY AN ENGINEERED BUILDING, SHOULD YOU?



Britespan[™]
BUILDING SYSTEMS INC

DESIGNED OR ENGINEERED?

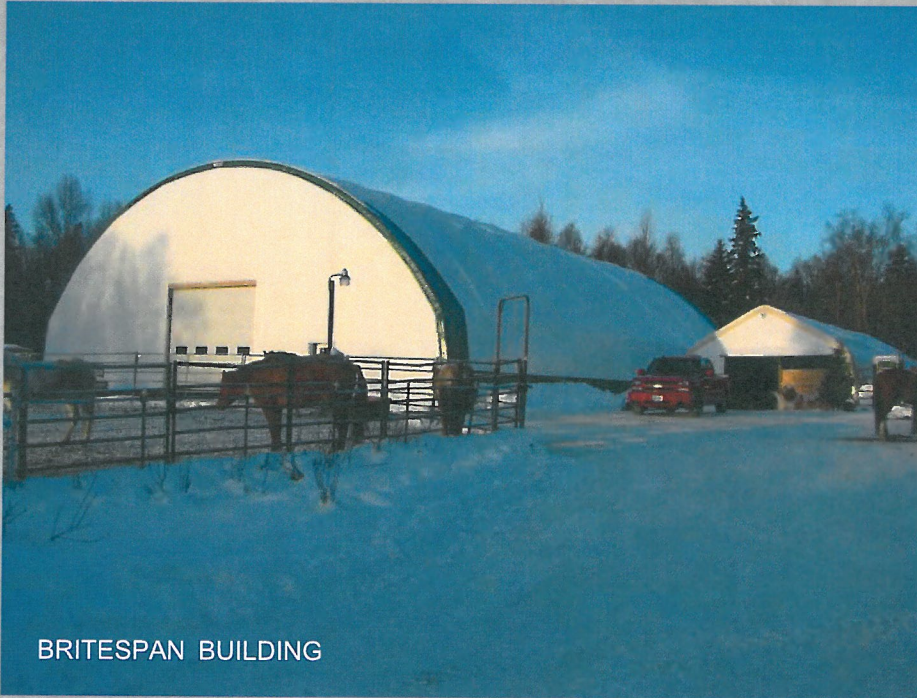

BRITESPAN BUILDING

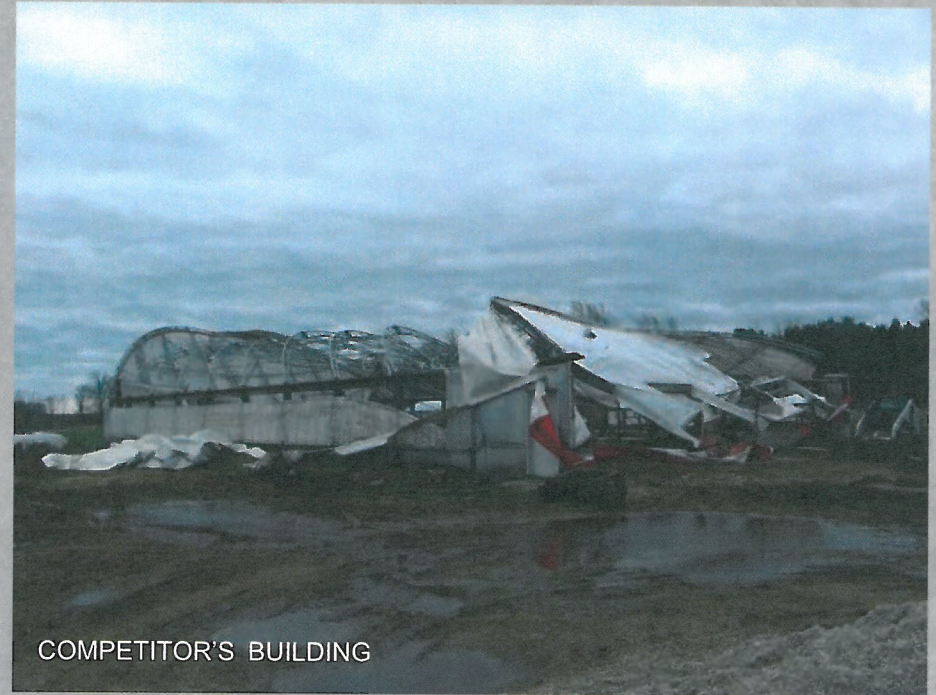

COMPETITOR'S BUILDING

WHICH WOULD YOU PREFER?

ENGINEERED FOR THE SITE

OR

DESIGNED FOR THE SITE

**BRITESPAN**
BUILDING SYSTEMS INC

SERVICE



WHICH WOULD YOU PREFER?

EXPERIENCED DEALER NETWORK OR COMPETITION'S CALL CENTER

Britespan[™]
BUILDING SYSTEMS INC

GALVANIZING



COMPETITOR'S BUILDING



COMPETITOR'S BUILDING

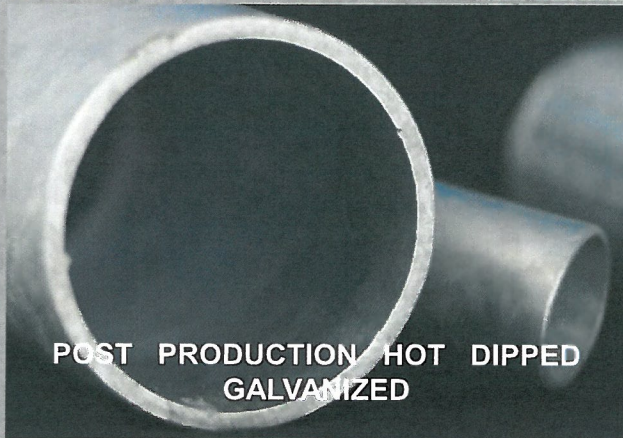

POST PRODUCTION HOT DIPPED GALVANIZED

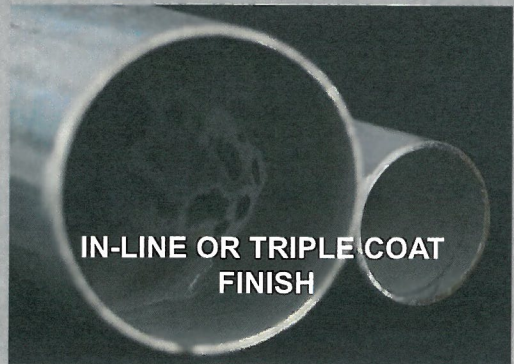

IN-LINE OR TRIPLE COAT FINISH

ROUND OR SQUARE TUBING?



ROUND TUBING INCREASES THE LIFE OF THE FABRIC AS THE EDGES ARE BLUNT WHERE THE FABRIC RIDES

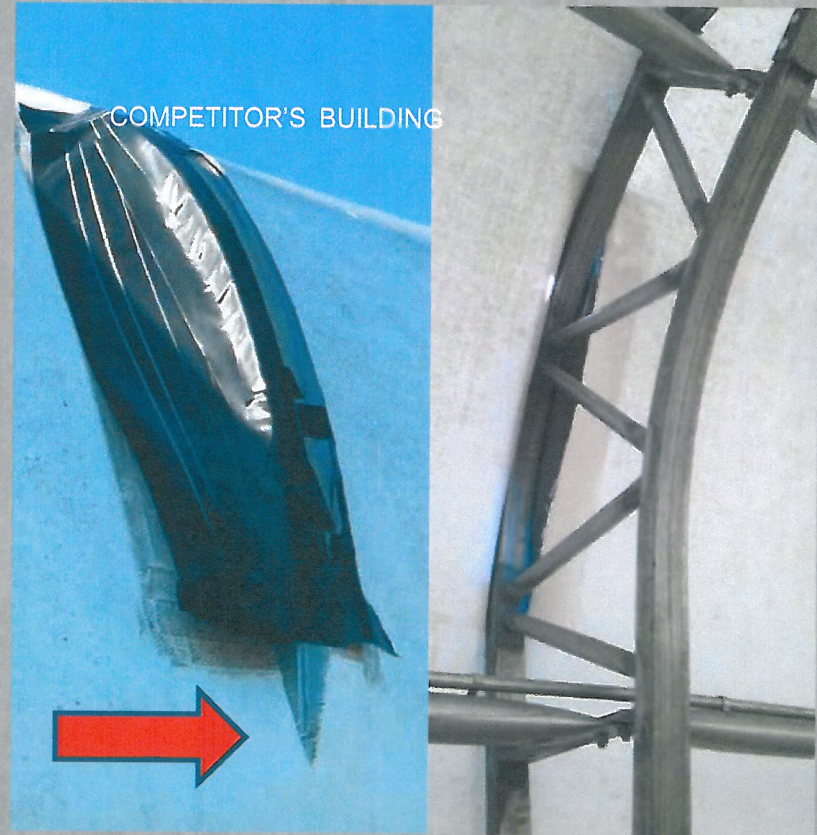

SQUARE TUBING ACTS LIKE A KNIFE AND CUTS THROUGH THE FABRIC UNDER TENSION

CHORD PLASTIFICATION



TRUSSES WITH SQUARE CHORDS OR TUBING THAT IS TOO THIN IS SUSCEPTIBLE TO CHORD PLASTIFICATION

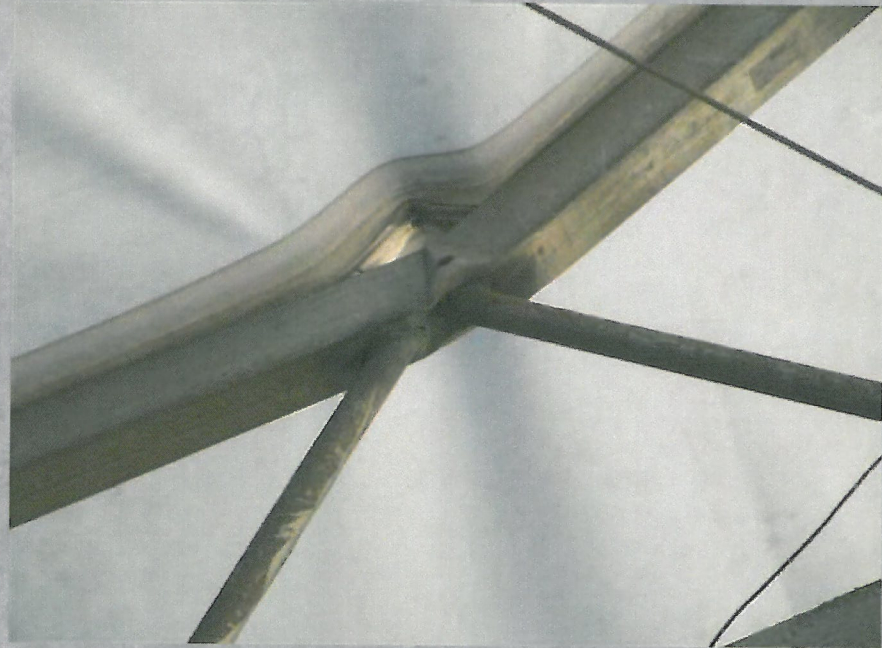

THIS IS WHEN THE WEBBING PUNCHES THROUGH THE CHORD CAUSING CATASTROPHIC FAILURE.

PURLIN ATTACHMENT



DOUBLE BOLTED TO AN ENGINEERED
STRUCTURAL MEMBER

BRITESPAN
BUILDING SYSTEMS INC



PURLIN SIZE AND CONSTRUCTION



1 PIECE CONSTRUCTION FOR MAXIMUM STRENGTH

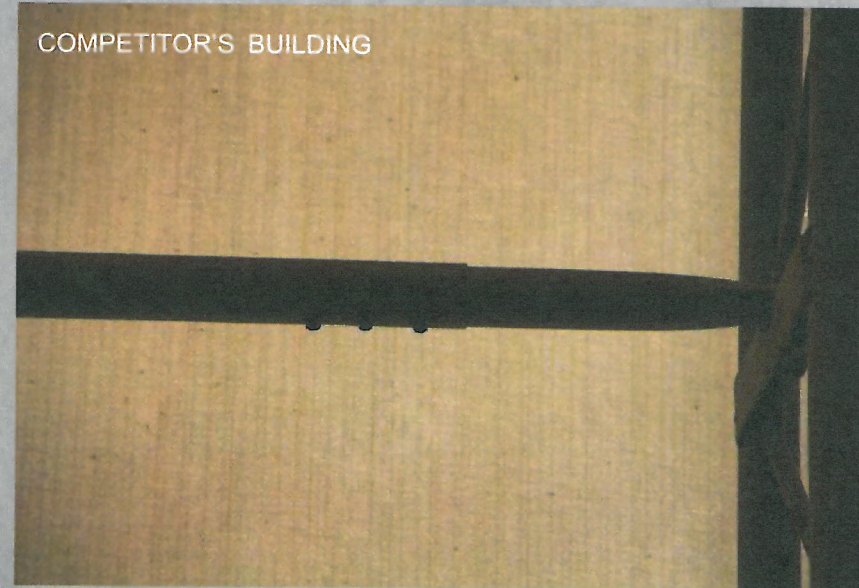

UNIVERSAL 1 SIZE FITS ALL CONSTRUCTION 3 TEK SCREWS OF STRENGTH

CABLES



**BOLTED AND PINNED TO AN ENGINEERED
STRUCTURAL TRUSS MEMBER**



COMPETITOR'S BUILDING

**CABLES WRAPPED AROUND SADDLE
BRACKETED PURLINS**

CABLES



WE USE CABLES THAT TERMINATE AT EVERY BAY WHICH ELIMINATES THE WEAR POINTS OF THE CABLES RUBBING THROUGH THE GALVANIZING ON THE TRUSS



CONTINUOUS CABLES RUNNING THROUGH TRUSS WEBS WITH NO ATTACHMENT TO ANYTHING ASIDE FROM THE FOUNDATION

WINCH or RATCHET



BRITESPAN
BUILDING SYSTEMS INC

10,000 lb WINCH BLOCKS FOR
ALL COVER ATTACHMENT

BRITESPAN
BUILDING SYSTEMS INC

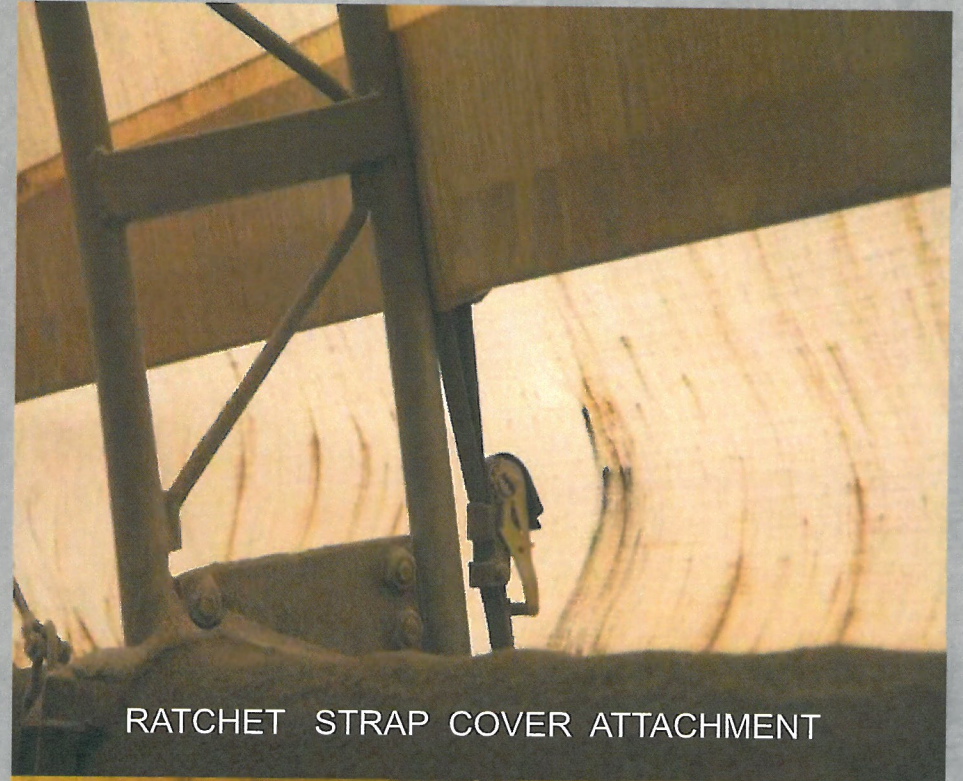

RATCHET STRAP COVER ATTACHMENT

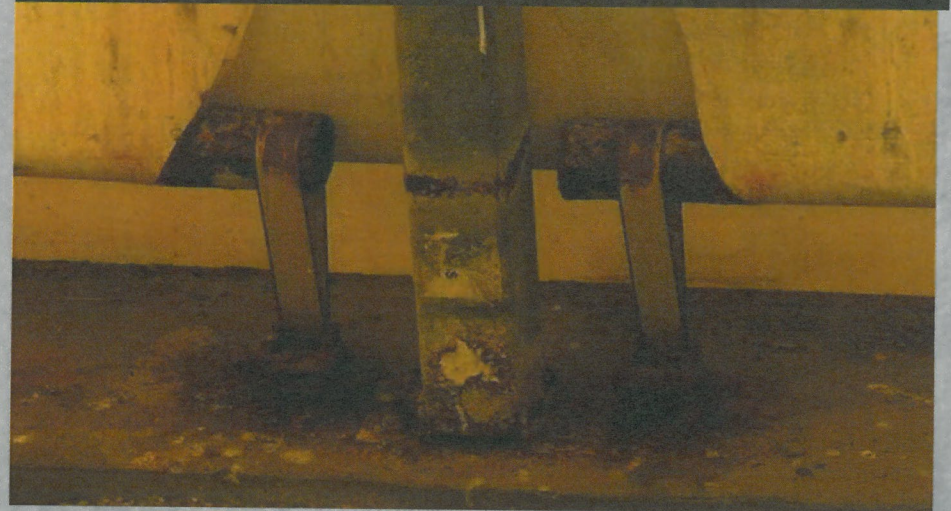

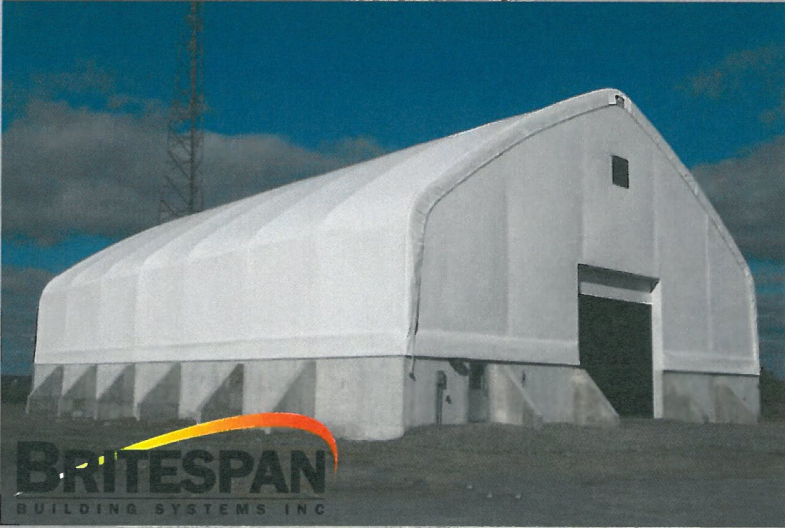
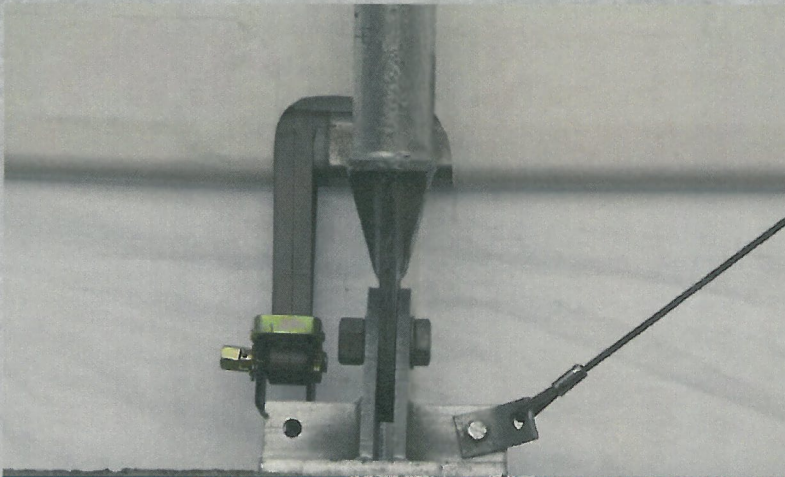

BRITESPAN USES LARGE AND/OR OVAL TENSION PIPE TO MAINTAIN PROPER TENSION OF THE COVER



COMPETITOR'S BUILDING



COMPETITOR'S BUILDING

SOME OF OUR COMPETITION USES 1-1/4" TENSION PIPE WHICH CAN RESULT IN PREMATURE FABRIC FAILURE

TENSION PIPE SIZE

TRUSS DEPTH



BRITESPAN'S TRUSSES START AT 18" DEEP

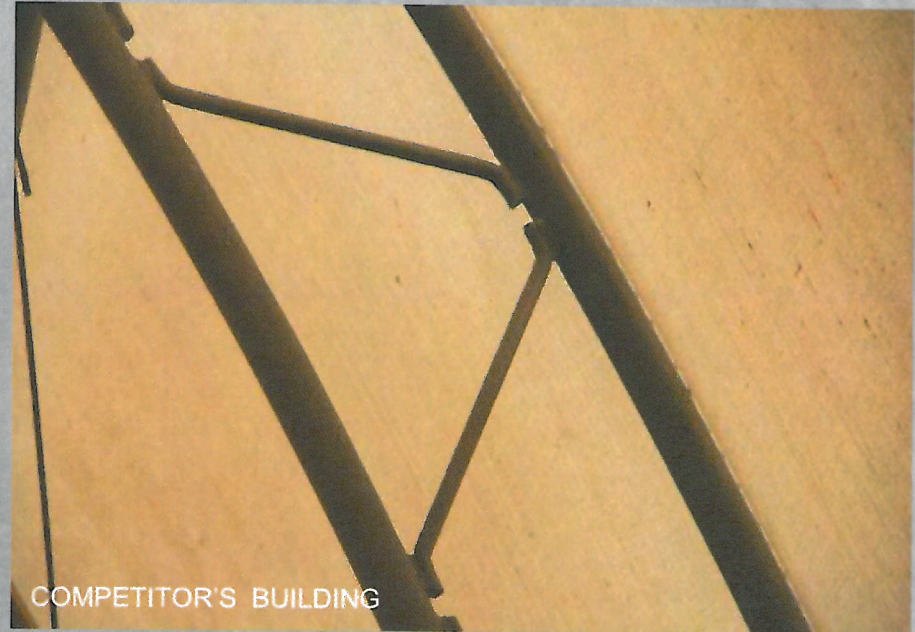

COMPETITOR'S TRUSSES ARE OFTEN 12" DEEP OR LESS AT THE SAME SPAN

TRUSS WEIGHT

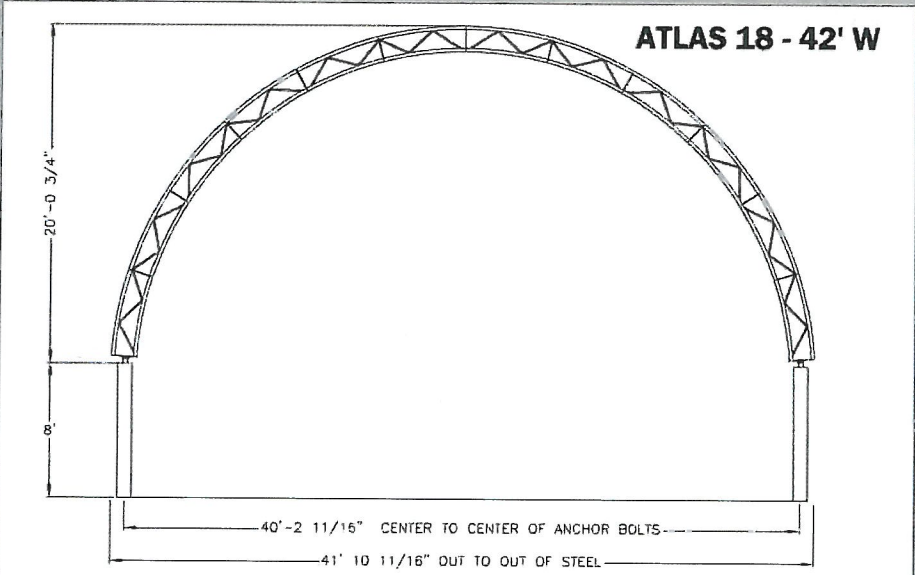

Britespan Building Systems 37451 Amberley Road Ludwigs, CA, Canada 900 2ND POC: 1-519-528-2922 FAX: 1-519-528-2890		SCALE: _____ CUSTOMER: _____ PROJECT: _____
DETAILER: LS CHECKER: LL	REVISED BY: DESCRIPTION 1 DATE: 15 FEB 12 THIS DRAWING IS PROPERTY OF BRITESPAN. ANY REPRODUCTION IN WHOLE OR IN PART WITHOUT THE EXPRESS WRITTEN CONSENT OF BRITESPAN IS PROHIBITED. THIS DRAWING IS NOT TO SCALE UNLESS OTHERWISE NOTED.	FILE NO: END-001 PROJECT ID: _____ SO/OBJECT ID: _____ DRAWING NO: _____ REV: 1

BRITESPAN'S ATLAS 18-42' TRUSS WEIGHS 560 POUNDS

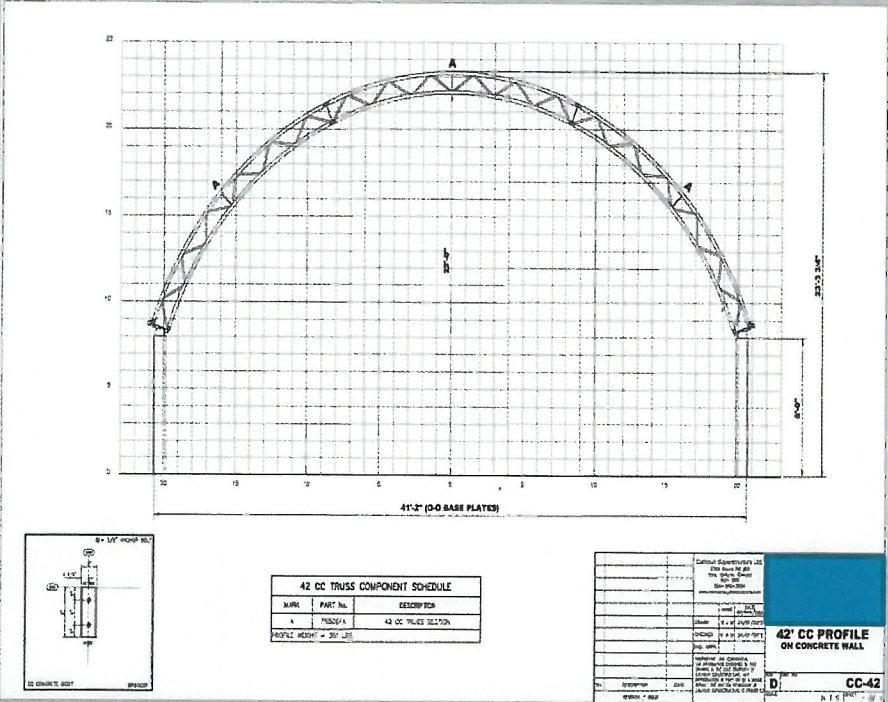

	42 CC TRUSS COMPONENT SCHEDULE <table border="1"> <thead> <tr> <th>MARK</th> <th>PART NO.</th> <th>DESCRIPTION</th> </tr> </thead> <tbody> <tr> <td>A</td> <td>TRUSS-A</td> <td>42 CC TRUSS SECTION</td> </tr> </tbody> </table> MODEL WEIGHT = 361 LBS	MARK	PART NO.	DESCRIPTION	A	TRUSS-A	42 CC TRUSS SECTION	<table border="1"> <tr> <td> Cultural Sportswear Ltd 100-100-1000 The City Centre 100-100-1000 </td> <td> 42' CC PROFILE ON CONCRETE WALL CC-42 </td> </tr> </table>	Cultural Sportswear Ltd 100-100-1000 The City Centre 100-100-1000	42' CC PROFILE ON CONCRETE WALL CC-42
MARK	PART NO.	DESCRIPTION								
A	TRUSS-A	42 CC TRUSS SECTION								
Cultural Sportswear Ltd 100-100-1000 The City Centre 100-100-1000	42' CC PROFILE ON CONCRETE WALL CC-42									

A COMPETITORS 42' TRUSS WEIGHS 361 POUNDS



TRUSS CLEARANCE

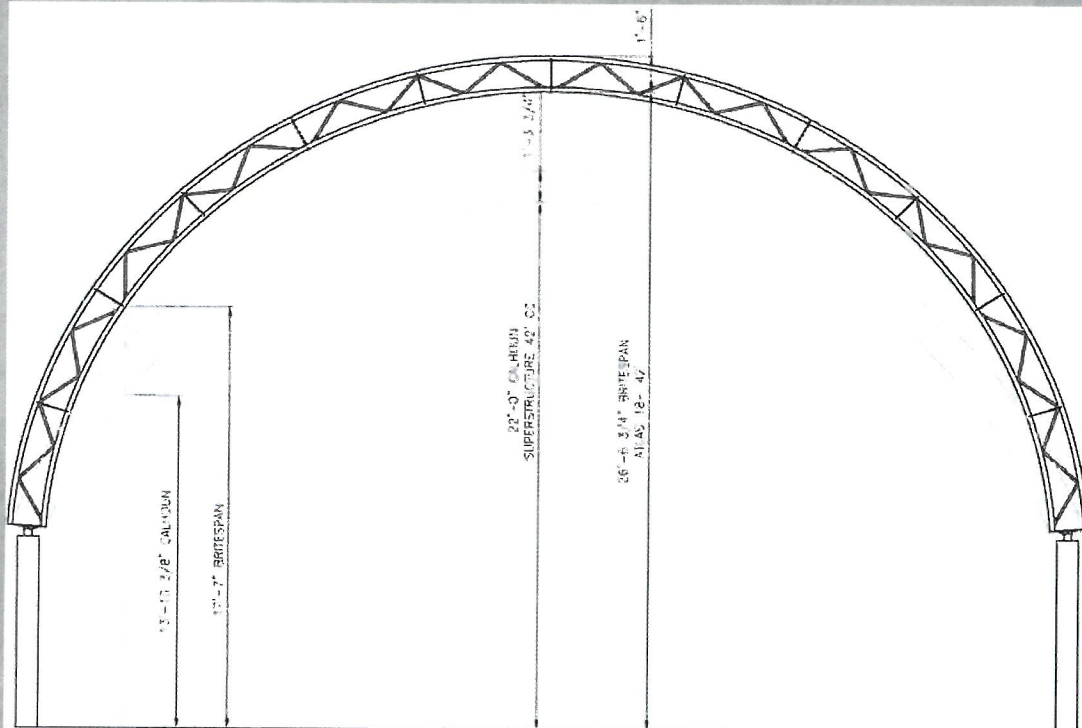

FABRIC CONSTRUCTION



EVERY BRITESPAN COVER IS HEAT WELDED
FOR UNMATCHED DURABILITY



COMPETITOR'S BUILDING

SOME COMPANIES STITCH THEIR COVERS
TOGETHER WHICH PERFORATES THE
FABRIC LEAVING IT SUSEPTABLE TO
TEARING

BRITESPAN
BUILDING SYSTEMS INC

NATURAL LIGHT



BRITESPAN BUILDING ON AN OVERCAST
DAY WITH LIGHTS TURNED OFF

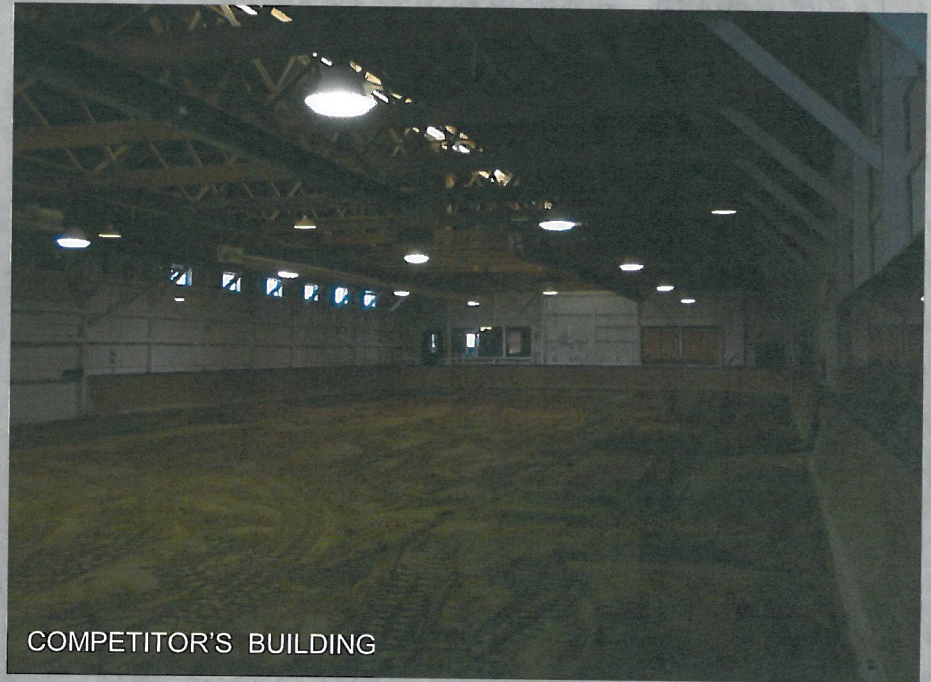

COMPETITOR'S BUILDING

POLE BARN WITH SKYLIGHT AND WINDOWS
ON A SUNNY DAY WITH LIGHTS ON

CUSTOMIZATION



BRITESPAN
BUILDING SYSTEMS INC

EAVES



RIDGE VENTS

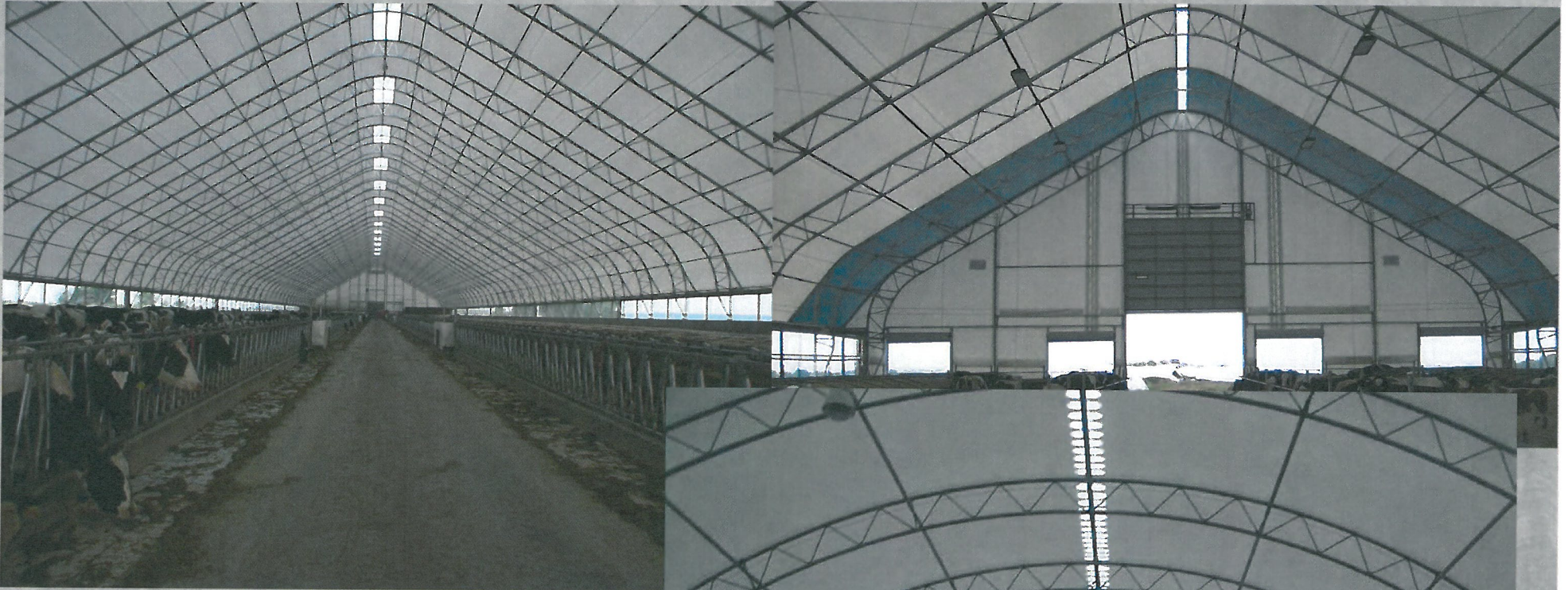

BRITESPAN[™]
BUILDING SYSTEMS INC

CURTAINS



BRITESPAN™
BUILDING SYSTEMS INC



Britespan
BUILDING SYSTEMS INC

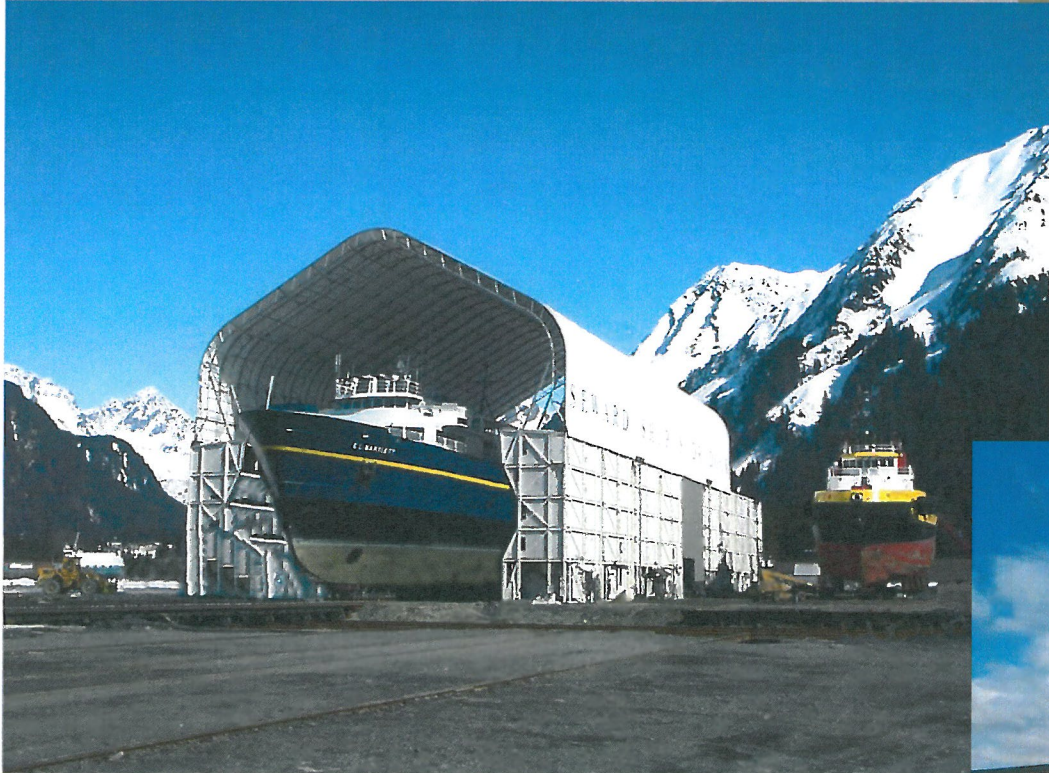

BRITESPAN™
BUILDING SYSTEMS INC

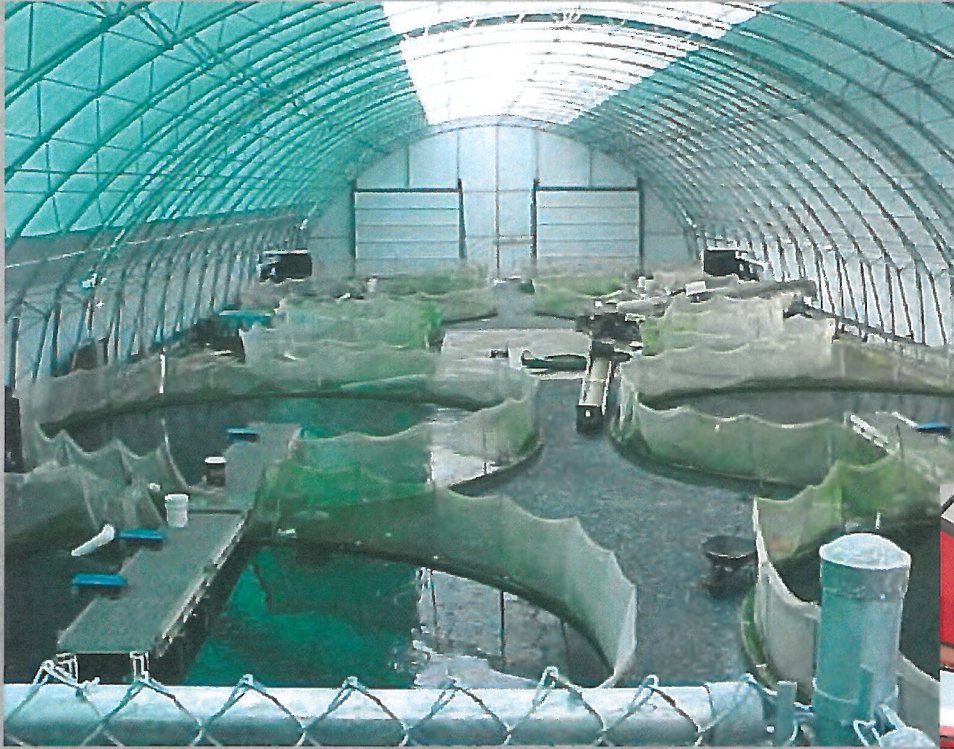

BRITESPAN™
BUILDING SYSTEMS INC



Britespan™
BUILDING SYSTEMS INC

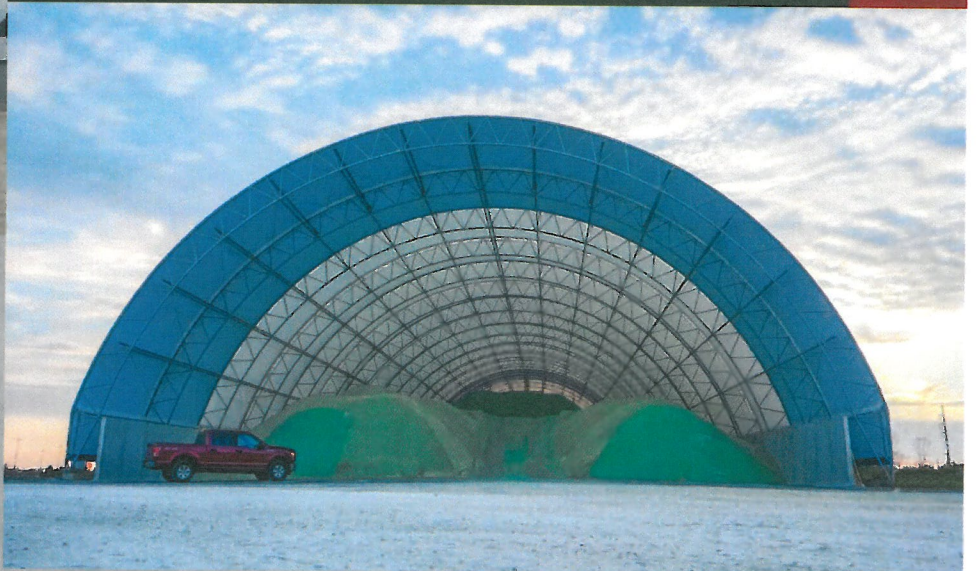

BRITESPAN™
BUILDING SYSTEMS INC

Certificate of Registration

This is to certify that CWB Registration has certified:



Plants: 688 Josephine Street North, RR1, Wingham, ON N0G 2W0
75 North Street West, Wingham, ON N0G 2W0 / 6 Kerr Crescent, Puslinch, ON N0B 1J0
Design Office: 688 Josephine Street North, RR1, Wingham, ON N0G 2W0

to the Certification Standard:

CSA A660-10

"Certification of Manufacturers of Steel Building Systems"

Initial Registration
September 24, 2010

Date of Issue
January 15, 2021

Date of Expiry
September 24, 2021

Certificate Number
OLYMP0

Scope: Design and manufacture steel building systems



A handwritten signature in black ink, consisting of several loops and strokes, positioned above a horizontal line.

Registrar



*Terms and Conditions governing registration and the use of this certificate are defined in the contract between CWB Registration and the Holder.
Contact the certificate holder for further information related to the scope and boundaries of the registration.*

ATLAS 18 - 32' W

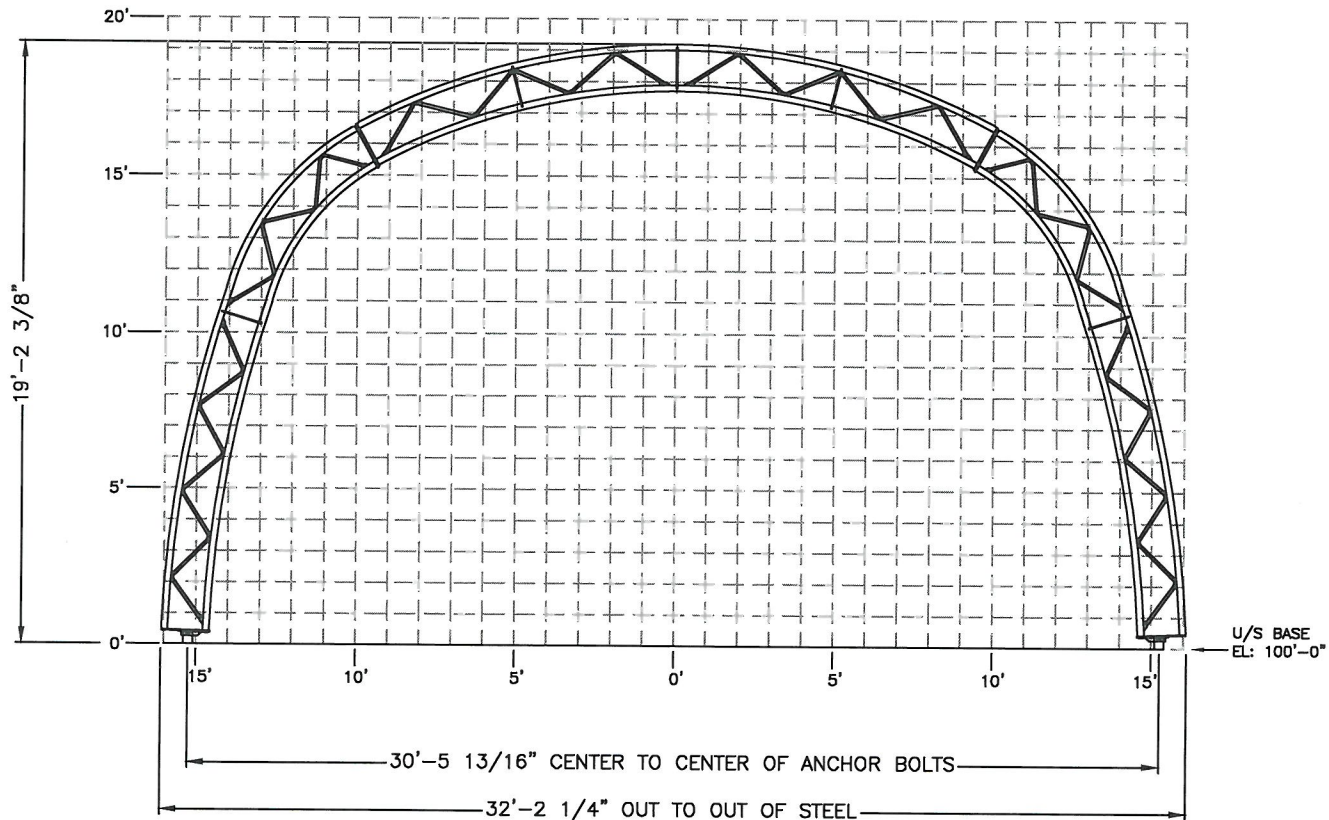

□ = 1' x 1' GRID

		37651 Amberley Road Lucknow, ON, Canada NOG 2H0 PH: 1-519-528-2922 FAX: 1-519-528-2890		DEALER:	CUSTOMER:	PROJECT:				
DETAILER: DS	DWG REV 1	REVISED BY: 1	DESCRIPTION	DATE 15.APR.13	THIS DRAWING IS PROPERTY OF BRITESPAN ANY REPRODUCTION IN WHOLE OR IN PART WITHOUT THE EXPRESSED WRITTEN CONSENT OF BRITESPAN IS PROHIBITED. THIS DRAWING IS NOT TO SCALE UNLESS OTHERWISE NOTED.	WIDTH-STEEL-FAB-HSS-HSSDROP 32	TAB TITLE: 005	DRAWING TITLE: ATLAS 32 - 320 GM PROFILE		
CHECKER: EM						FILE NO: END-001	PROJECT ID:	SO/ORDER ID:	DRAWING:	REV: 3

This project has been designed and fabricated in accordance with the following:

1. DESCRIPTION
 Owner: Name and Address: WV DIVISION OF HIGHWAYS - RICHARD FERRELL
 BURNSVILLE HQTS RT.1 BOX 435 BURNSVILLE, WV 26135

Building Supplier's Name and Address: COVER-ALL BUILDINGS OF WV INC.
 P.O. BOX 727 BRIDGEPORT, WV 26030

Manufacturer's Name and Address: BRITESPAN BUILDING SYSTEMS INC.
 68 JOSEPHINE ST. N. RR#1 WINNAM, ON MILLS, WV

Site Location: BURNSVILLE HQTS RT.1 BOX 435 BURNSVILLE, WV 26135

Legal Address: BURNSVILLE HQTS RT.1 BOX 435 BURNSVILLE, WV 26135

Building Type: ATLAS 18
 40' x 70' @ 14' o.c. (10' @ 14' o.c.)

Applicable Building Code: ASCE 7-10 IBC 2015

Intended Use and Occupancy: SALT SAND

Use Group: S-Low Hazard

Fabric Type: RUBX-6-400

2. DESIGN STANDARDS
 The design is per ASCE 7-10 SECTION 2.4.1 Allowable Truss Design, WEST VIRGINIA Building Code with 2014 IRC amendments, Minimum Design Loads for Buildings and Other Structures, ASCE 7-10 Specification for Structural Steel Buildings (AISC 360-10), North American Specification for the Design of Cold-Formed Steel Structural Members NFPA 791, Standard Methods of Fire Tests for Flame Propagation of Textiles and Films, NFPA 705 Edition.

3. MANUFACTURING STANDARDS
 Fabrication in accordance with ANSI, AISC 360-10 and AISC 308, as applicable. Welding in accordance with AWS D1.1 and D1.3 Structural Welding Code and AWS-F105, as applicable. BRITESPAN Building Systems Inc. is an AWS approved fabricator as per BS 17 and QC17 standards. Welders have been qualified in accordance with AWS-Q1.

4. DESIGN CRITERIA

Risk Category	RISK CATEGORY I
Exposure Category	EXPOSURE C (WIND FULLY EXPOSED)
Enclosure Category	PARTIALLY ENCLOSED

A) DEAD LOADS
 1. Weight of Building Components
 2. Calculated (hangup) load not to exceed 0.25 psf as an allowance for mechanical, electrical, ceiling, sprinklers, etc. or any combination thereof.

B) LIVE LOADS
 Live Loads (l_l) in accordance with ASCE 7-10 IBC 2015
 Minimum roof live load: 1 psf

C) SNOW LOADS
 Snow loads determined in accordance with ASCE 7-10 IBC 2015
 Ground Snow Load (p_g) (psf): 10 psf
 Roof Snow Load (p_s) (psf): 21.1 psf
 Exposure Factor (C_e): 1.0
 Thermal Factor (C_t): 1.2
 Importance Factor (I_s): 0.8
 Sloped Roof Snow Coefficient (C_s): 0.72 (Normal)

D) WIND LOADS
 Wind loads determined in accordance with ASCE 7-10 IBC 2015
 Wind Speed (V) (mph): 105 mph
 Basic Wind Pressure (q_s) (psf): 21.6 psf
 Exposure Coefficient (K_z): 0.75
 Topography Factor (K_t): 1.0
 Directionality Factor (K_d): 1.0
 Wind load not to be less than applicable minimum load components that include wind.

E) LOAD COMBINATIONS
 Load combinations determined in accordance with ASCE 7-10 IBC 2015

BASE REACTIONS
 THE MAXIMUM FORCES AT THE HINGE SUPPORTS OF TRUSS DUE TO THE LOADS LISTED ABOVE ARE AS FOLLOWS
 NOTE: REACTIONS AT COMMON OR INTERNAL TRUSSES - END TRUSSES HAVE 1/2 TRIBUTARY WIDTH

LOAD CASE	SIDE A		SIDE B	
	HORIZONTAL X ₁ (kips)	VERTICAL Y ₁ (kips)	HORIZONTAL X ₂ (kips)	VERTICAL Y ₂ (kips)
DEAD	0.07	0.14	-0.07	0.14
COLLATERAL	0.04	0.07	-0.04	0.07
LIVE	1.83	2.81	-1.83	2.85
SNOW BALANCED	2.87	4.27	-2.87	4.27
SNOW UNBALANCED	1.81	1.44	-1.81	5.26
WIND PERPENDICULAR	-0.97	1.16	-0.39	0.72
WIND PARALLEL	1.12	-3.50	1.09	-3.91

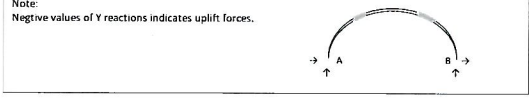

GENERAL
 THIS DRAWING INCLUDES INFORMATION HEREON REGARDING THE PROPERTY OF BRITESPAN BUILDING SYSTEMS, INC. IT IS PROVIDED SOLELY FOR ERECTING THE BUILDING DESCRIBED IN THE SHEET ORDER AND SHALL NOT BE REPRODUCED, REPRINTED, OR USED FOR ANY OTHER PURPOSE WITHOUT PRIOR WRITTEN APPROVAL OF BRITESPAN BUILDING SYSTEMS, INC.

THE GENERAL CONTRACTOR AND/OR ERECTOR IS SOLELY RESPONSIBLE FOR ACCURATE QUALITY WORKMANSHIP IN ERECTING THE BUILDING IN CONFORMANCE WITH THIS DRAWING. DETAILS REFERENCED IN THIS DRAWING AND INDUSTRY STANDARDS PERTAINING TO TEMPORARY ERECTION INCLUDING THE PROPER USE OF TEMPORARY BRACING.

THIS BUILDING IS NOT DESIGNED TO BE LIFTED AS AN ASSEMBLED UNIT. BRITESPAN BUILDING SYSTEMS, INC. IS NOT RESPONSIBLE FOR LOSSES AND/OR DAMAGE AS A RESULT OF LIFTING THIS BUILDING. IF HOWEVER, IT HAS BEEN DETERMINED TO LIFT THIS BUILDING, IT IS THE RESPONSIBILITY OF THE PERSON, FIRM OR COMPANY CONTRACTED TO LIFT THE BUILDING TO SECURE THE SERVICES OF A QUALIFIED ENGINEER TO ENSURE THE LIFT DOES NOT DAMAGE THE BUILDING. IT IS THE RESPONSIBILITY OF THE LIFTER TO OBTAIN ALL NECESSARY PERMITS AND TO OBTAIN ALL NECESSARY INSURANCE COVERAGE TO DETERMINE ANY FINANCIAL ASPECTS OF THE LIFT INCLUDING ALL PARTS, CONNECTORS TO BE ADDED TO THE BUILDING TO FACILITATE THE LIFT.

BRITESPAN BUILDING SYSTEMS, INC. IS NOT RESPONSIBLE FOR ERECTOR DAMAGE OR DAMAGES INCURRED IN THE ERECTION OF THE COMPONENTS SHOWN ON THIS DRAWING NOR FOR THE INSPECTION OF ERECTED COMPONENTS TO DETERMINE THE SAME.

THIS CERTIFICATION AND ENGINEERING SEAL APPLIES ONLY TO PRODUCTS DESIGNED AND FABRICATED BY BRITESPAN BUILDING SYSTEMS, INC. FOR THE LOADING CONDITIONS DESIGNED ON THESE DRAWINGS. COMPLETE FOUNDATIONS, STEEL COMPONENTS BY OTHERS AND ERECTION SUPERVISION ARE NOT THE RESPONSIBILITIES OF BRITESPAN BUILDING SYSTEMS, INC. THE CERTIFYING ENGINEER ALL DESIGN, WINDLOADS AND BRACING CONDITIONS MUST BE DESIGNED TO SUPPORT THE SITE WIND LOADING AND ARE RELIED ON TO BE CLOSED IN THE EVENT OF HIGH WINDS.

ANCHOR BOLTS
 ANCHOR BOLT DIAMETERS ARE DETERMINED IN ACCORDANCE WITH A MINIMUM TENSILE STRENGTH OF F_y = 75 KSI (511 MPa). ANCHOR BOLT LENGTHS AND LOAD TRANSFER TO THE FOUNDATION ARE TO BE DETERMINED BY OTHERS.

ANCHOR BOLT PROJECTIONS AND LENGTHS ARE RESPONSIBILITY OF FOUNDATION ENGINEER.

FOUNDATION MUST BE LEVEL, SQUARE AND SMOOTH. ANCHOR BOLTS MUST BE ACCURATELY PLACED AS SHOWN ON THE DRAWINGS.

FINISHED FLOOR ELEVATIONS AND UNDERSIDE OF BASE PLATE IS 10' 0" UNLESS NOTED.

ERECTION
 THE ERECTOR MUST PROVIDE SAFE WORKING CONDITIONS AND PRACTICES CONFORMING TO ALL SAFETY REGULATIONS. ALL THE LIFTING DEVICES TO BE SPECIFICALLY DESIGNED TO LIFT THE VARIOUS BUILDING COMPONENTS. SLINGS AND SPREADER BARS ARE TO BE USED TO PREVENT PERMANENT DEFORMATION OF ALL STRUCTURAL MEMBERS.

ERECTION SHOULD START AT A BRACED BAY. ERECT AND TEMPORARILY SUPPORT TRUSSES, USE TEMPORARY BRACING AS REQUIRED TO ENSURE STABILITY OF THE FRAME. INSTALL PURLINS AND CROSS BRACING, PLUMB AND SQUARE TRUSSES IN ACCORDANCE WITH CAN-S16-1 AND CSA S4-16 (OR PART 109 - SAFETY STANDARD FOR STEEL ERECTION).

ENSURE ALL PURLINS REMAIN PARALLEL.

STRUCTURAL FRAME MEMBERS ARE CONSIDERED PLUMB LEVEL AND ALIGNED WHEN THE VARIANCE DOES NOT EXCEED 1/8".

STRUCTURAL BOLTS
 BOLTS IN CONNECTIONS NOT SUBJECT TO TENSION LOADS OR WHERE JOGGING DUE TO VIBRATION OR LOAD FLUCTUATIONS ARE NOT DESIGN CONSIDERATIONS NEED ONLY BE SNUG TIGHTENED WHICH IS DEFINED AS TIGHTENING THAT EXISTS WHEN ALL PILES IN A JOINT ARE IN FIRM CONTACT. ALL STRUCTURAL BOLT DIAMETERS LESS THAN 1" CONFORM TO SAE A490 GRADE, BE PLATED / GALVANIZED OR JSSCO COATED FINISH. ALL STRUCTURAL NUT DIAMETERS LESS THAN 1" CONFORM TO SAE J959 GRADE, BE PLATED / GALVANIZED OR JSSCO COATED FINISH.

ALL BOLTS LARGER THAN 1" DIA. CONFORM TO ASTM A325
 ALL OTHER DIA. HEAD BOLTS CONFORM TO THE GRADE OF THE PLATE.
 ALL BOLT REFERENCES REQUIRE BOTH BOLT AND NUT.

BOLTS IN CONNECTIONS NOT SUBJECT TO TENSION LOADS SHALL BE SNUG TIGHTENED PER RSSC 1.1. THE FOLLOWING TENSION SCHEDULE IS PROVIDED FOR REFERENCE.

TABLE A - BOLT TENSION	
SIZE	GRADE 5
5/8"	18
3/4"	28
7/8"	39
1.0"	51
SIZE	A315
1/2"	15
3/4"	16
1/2"	74
1/2"	106

STRUCTURAL BOLT TORQUE VALUES (AS REFERENCE ONLY, RSSC APPROVED METHOD) REQUIRED WHERE APPROPRIATE. TABLE B LISTS THE BOLT Q-LAMP WITH SUGGESTED ASSEMBLY TORQUE VALUES.

TABLE B - IMPERIAL						
SIZE	DIA.	Threads Per Inch	GRADE 5			
			Tensile Min	Proof Load Lbs	Clamp Load Lbs	Torque Dry Lbs-ft
3/8"	18	120	6600	4950	15	23
7/16"	14	120	9010	6780	50	35
1/2"	13	120	12100	9050	75	55
5/8"	11	120	18200	14100	150	110
3/4"	10	120	28400	21300	200	200
SIZE	GRADE 305					
1 1/4"	7	105	71700	53900	1170	840
1 1/2"	7	135	103000	77300	1775	1330

MATERIAL SPECIFICATIONS
 ROLLED STRUCTURAL SECTIONS CONFORM TO ASTM A36 - A36M-14 (40W - 50W)

STRUCTURAL PLATE CONFORMS TO THE FOLLOWING SPECIFICATIONS:
 PLATES: ASTM A672 OR A2 54 & CSA C43.30 200W / 250W
 H.S.S.: ASTM A500 GRADE C / CSA C43.40 24 35W

COATINGS OF STRUCTURAL STEEL AND KING PURLINS ARE HOT-DIP GALVANIZED IN ACCORDANCE WITH A123 / A123M-17.

ALL WELDED COMPONENTS (TRUSSES) ARE HOT-DIP GALVANIZED INSIDE AND OUT IN ACCORDANCE WITH A123 / A123M-17.

PURLINS AND DOWNPIPE ARE PRE-GALVANIZED.

DIAGONAL BRACING STEEL CABLES EXTRA HIGH STRENGTH PER ASTM A475-01 (204), CROSS CABLES - 0.5" x 1/8" TYP.

STRUCTURAL COMPONENTS ARE AS FOLLOWS:
 2" x 3" CORNER: 1/4" x 1/8" (1/4" DIA. WEBS & 7/8" PURLIN)

ALL OTHER SIZE: (3/16" x 1/8" MIN. YIELD = 50ksi)

ERECTOR INSTRUCTIONS
 EXTERIOR FABRIC IS AN INTEGRAL PART OF THE STRUCTURAL FRAME. DO ALTERATION WITHOUT PRIOR AUTHORIZATION IS PROHIBITED. ALL TEARS MUST BE PATCHED IMMEDIATELY TO AVOID WARRANTY PROBLEMS.

EXTERIOR FABRIC WILL DEFLECT UNDER LOAD. THEREFORE ALL BUILDING ACCESSORIES (LIGHTING, SIGN, SPRINKLERS, ETC.) MUST BE LOCATED BENEATH THE INTERIOR OF THE TRUSS. ANYTHING ABOVE THIS MUST BE REVIEWED AND APPROVED IN WRITING BY BRITESPAN BUILDING SYSTEMS, INC. SEVERE DAMAGE TO THE BUILDING AND ACCESSORIES MAY RESULT FROM FAILURE TO COMPLY WITH THIS REQUIREMENT.

FABRIC SPECIFICATIONS
 ALL POLYETHYLENE MEMBRANES WILL POSSESS THE FOLLOWING MINIMUM SPECIFICATIONS:

NON-FR - RUBX-6-400

Physical	Properties	Description
WEAVE	Woven clear HDPE scrim	
WEAVE	4 mil (95 gsm / ft ²)	
COATING	12 oz yd ² (407 g/m ²) +/-5%	
WEIGHT	23 mil (0.59 mm)	
THICKNESS	WARP +/- 0 lb 1664 N	ASTM D-1777
GRAB TENSILE	WEFT 345 lb 1532 N	ASTM D-5034
STRIP TENSILE (N/5cm)	WARP 245 lbfm (2175)	ASTM D-4851
	WEFT 235 lbfm (2088)	
STRIP TENSILE (Standard deviation)	WARP 9.8 / WEFT 12.4	ASTM D-4851
FACTORED MEMBRANE	WARP 145 lbfm (1297)	
	WEFT 122 lbfm (1083)	
RESISTANCE (Tr) (N/5cm)	WARP 0.88 / WEFT 0.83; H=1.0, U=0.75, V=0.8	ASTM D-4851
CSA S308-12 where	WARP 110 lb 488 N	ASTM D-2261
TONGUE TEAR	WEFT 110 lb 488 N	
	WEFT 100 lb 444 N	
TRAPEZOIDAL TEAR	WARP 95 lb 422 N	ASTM D-4513
	WEFT 90 lb 403 N	
MULLEN BURST	655 psi (4512 kPa)	ASTM D-3786
LOW TEMPERATURE BEND	PASS -70°F/-60°C	ASTM D-2136
FR PERFORMANCE	RUBX-6-400	ASTM E94-00a

DRAWING SCHEDULE		RELEASE			
DWG #	DRAWINGS TITLE	REL.	DATE	REL.	DATE
FB-1	COVER PAGE	0	02.AUG.2019		
FB-2	BASEPLATE LAYOUT	0	02.AUG.2019		
BD-1	BASEPLATE DETAILS	0	02.AUG.2019		
FB-3	PROJECT LAYOUT	0	02.AUG.2019		
FB-4	PURLIN & X-CABLE LAYOUT	0	02.AUG.2019		
FB-5	BRACING LAYOUT - PLAN VIEW	0	02.AUG.2019		
FB-6	BRACING LAYOUT - ELEVATION	0	02.AUG.2019		
EW-1	ENDWALL 1 LAYOUT	0	02.AUG.2019		
EW-2	ENDWALL 2 LAYOUT	0	02.AUG.2019		
SD-1	STANDARD DETAILS 1	0	02.AUG.2019		
SD-2	STANDARD DETAILS 2	0	02.AUG.2019		
SD-3	STANDARD DETAILS 3	0	02.AUG.2019		
ED-1	ENDWALL DETAILS	0	02.AUG.2019		

PILOT PLAN NOTES
 UNLESS NOTED, THE 0.5" DIA. BOLTS FOR PURLIN TO TRUSS, CABLE OR ROD BRACING TO TRUSS AND ANGLES TO TRUSS FOR ALL CONNECTIONS.

CABLE / ROD AND PURLIN BRACING ARE AN INTEGRAL PART OF THE TRUSS STRUCTURAL SYSTEMS AND SHOULD BE PROPERLY INSTALLED PRIOR TO ERECTION OF FABRIC ROOF AND ENDWALL PANELS. REMOVE OR ALTERATION OF ANY BRACING WITHOUT PRIOR AUTHORIZATION FROM BRITESPAN BUILDING SYSTEMS, INC. IS PROHIBITED.

ELEVATION NOTES
 HOLES REQUIRED IN HSS COLUMNS, HEADERS, OR PURLINS FOR FRAMED OPENINGS - FIELD DRILLED, DOOR OR WINDOW PILE CONNECTIONS TO BE BY ERECTOR.

WALK DOOR, WINDOW AND FRAMED OPENING PILES TO BE FIELD ANCHORED TO CONCRETE WITH 0.5" DIA. MULTI KWIK-BOLTS (1) MINIMUM.

MATERIAL STORAGE
 GALVANIZED ALUMINUM AND COLORED MATERIALS ARE SUBJECT TO CORROSION AND DISCOLORATION IF THEY ARE IMPROPERLY STORED. SHORT TERM ON-SITE STORAGE OF STEEL COMPONENTS MUST BE TO GRADED PAVED GROUND. IT IS THE RESPONSIBILITY OF THE ERECTOR TO KEEP THE MATERIALS DRY AT ALL TIMES. WHEN TRUSSES ARE TO BE STORED OUTDOORS, THEY SHOULD BE PLACED AT AN ANGLE SUFFICIENT TO PROMOTE GOOD DRAINAGE. IN ADDITION, SEVERAL INCHES OF CLEARANCE MUST BE PROVIDED BETWEEN THE LOWER END AND THE GROUND TO ALLOW VENTILATION.

NOTE: BRITESPAN BUILDING SYSTEMS, INC. WILL NOT BE HELD RESPONSIBLE FOR MATERIALS WHICH ARE IMPROPERLY PROTECTED AFTER DELIVERY.

BRITESPAN BUILDING SYSTEMS, INC. IS AN AIAA CERTIFIED DESIGNER MANUFACTURER OF TRUSSES. ALL VELLO'S ARE COMPLETED IN SHOP AS PER AWS STANDARD 4.3.3 AS PART OF OUR QUALITY ERECTION AN INDEPENDENT THIRD PARTY TESTS OUR WELDERS AND PROCEDURES AND AUDITS OUR FACILITIES. THIS CERTIFICATION MEETS WITH AWS D1.1 AND D1.3 CRITERIA.

FOUNDATION DESIGN IS NOT BY ENGINEER OF STRUCTURE UNLESS BY SEPARATE SIGNED CONTRACT.
 MINIMUM EDGE DISTANCE OF ANCHOR BOLT CENTRELINE TO EDGE OF CONCRETE FOUNDATION SHALL BE 4 INCHES. ANCHOR DESIGN IS BY FOUNDATION ENGINEER.

FOUNDATION DESIGNER SHALL DETERMINE ANCHOR BOLT SIZE AND TYPE FOR BRITESPAN LOADS. PROPER MINIMUM EDGE DISTANCE FROM CENTER OF ANCHOR TO EDGE OF CONCRETE SIDEWALLS AND ENDWALLS SHALL BE PROVIDED FOR THE ANCHOR TYPE. FOUNDATION DESIGN IS NOT BY BRITESPAN BUILDING SYSTEMS, INC.

*** MAINTENANCE REQUIREMENTS FOR THE STRUCTURE ***

Years 1 - 2 every 12 months - 10% of all cable tensioning requested and reported in writing to BRITESPAN and Engineer of structure.
 Years 3 - 19 every 18 months - 25% of all cable tensioning requested, however, where necessary, record and check all other similar cable tensioning information to BRITESPAN and Engineer of structure.

*** NOTE ***

TEMPORARY BRACING / SUPPORT IS REQUIRED DURING ERECTION OF BUILDING. BRACING MUST REMAIN IN PLACE UNTIL STRUCTURE AND ALL PERMANENT BRACING IS COMPLETELY INSTALLED.
 TEMPORARY BRACING DESIGN AND SUPPLY IS NOT THE RESPONSIBILITY OF BRITESPAN BUILDING SYSTEMS, INC.

TF: 800-407-5846
 www.britespanbuildings.com

REV #	CR #	DESCRIPTION	DATE
0		ISSUED FOR CONSTRUCTION	02.AUG.2019

DEALER
 COVER-ALL BUILDINGS OF WV INC.
 P.O. BOX 727
 BRIDGEPORT, WV. 26330

CUSTOMER
 WV DIVISION OF HIGHWAYS
 BURNSVILLE HQTS RT.1 BOX 435
 BURNSVILLE, WV. 26335

THIS DRAWING IS PROPERTY OF BRITESPAN BUILDING SYSTEMS, INC. ANY REPRODUCTION IN WHOLE OR IN PART WITHOUT THE EXPRESSED WRITTEN CONSENT OF BRITESPAN BUILDING SYSTEMS, INC. IS PROHIBITED. THIS DRAWING IS NOT TO SCALE UNLESS OTHERWISE NOTED.

DRAWN BY:
TWF

CHECKED BY:
CJM

PROJECT	ORDER ID	DRAWING TITLE
ATLAS 18 40' x 70' - 320 GM 14' oc	SO# 6855-01	COVER PAGE

WIDTH-STEEL-FAB-HSS-HSSDRUP:
 40-320-220-18-//

SHEET NO.: FB-1
 PAGE NO.: 001/13

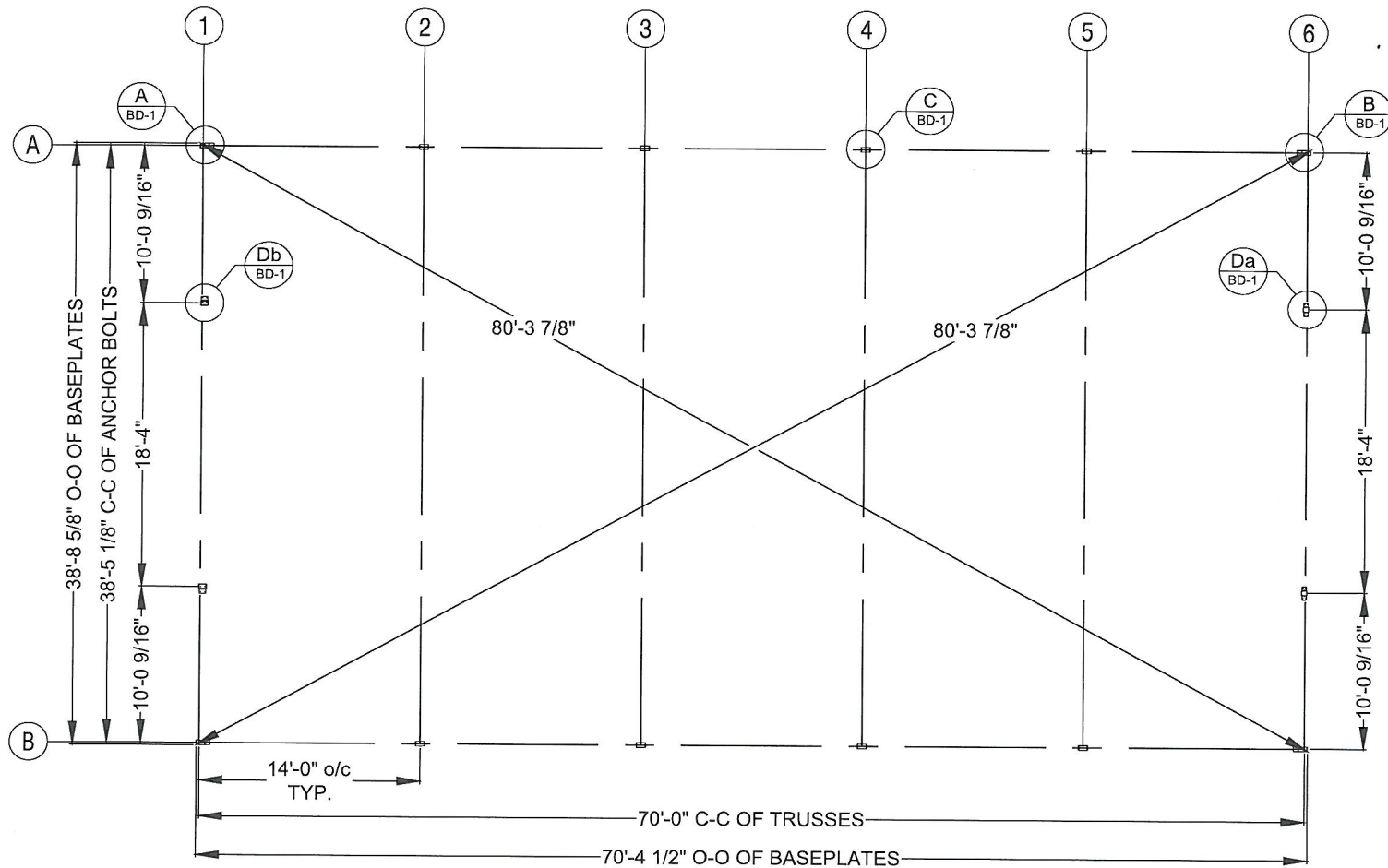

TF: 800-407-5846
www.britespanbuildings.com

REV #	CR #	DESCRIPTION	DATE
0		ISSUED FOR CONSTRUCTION	01 AUG 2019

DEALER:
COVER-ALL BUILDINGS OF WV INC.
P.O. BOX 727
BRIDGEPORT, WV. 26330

CUSTOMER:
WV DIVISION OF HIGHWAYS
BURNSVILLE HQTS RT.1 BOX 435
BURNSVILLE, WV. 26335

THIS DRAWING IS PROPERTY OF BRITESPAN BUILDING SYSTEMS INC. ANY REPRODUCTION IN WHOLE OR IN PART WITHOUT THE EXPRESSED WRITTEN CONSENT OF BRITESPAN BUILDING SYSTEMS INC. IS PROHIBITED. THIS DRAWING IS NOT TO SCALE UNLESS OTHERWISE NOTED.

DRAWN BY:
TWF
CHECKED BY:
CJM

PROJECT:
ATLAS 18
40' x 70' - 320 GM
14' oc

ORDER ID:
SO# 6855-01
WIDTH-STEEL-FAB-HSS-HSSDROP:
40-320-220-18-//

DRAWING TITLE:
BASEPLATE LAYOUT
SHEET NO.: FB-2
PAGE NO.: 002 /13

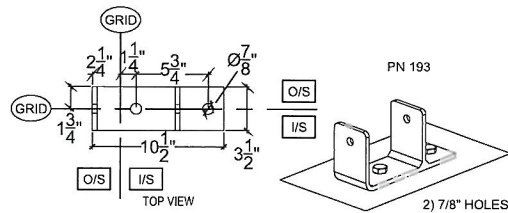

A ATLAS 18 - LEFT
BD-1 BASEPLATE DETAIL

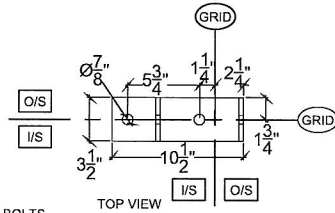

B ATLAS 18 - RIGHT
BD-1 BASEPLATE DETAIL

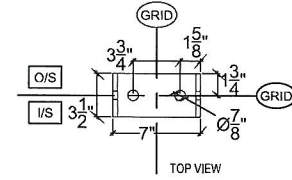

C ATLAS 18 - COMMON
BD-1 BASEPLATE DETAIL

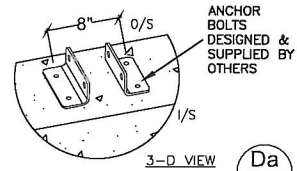

Da 4X4 HEADER / BASE
BD-1 BASEPLATE DETAIL

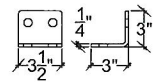

ANCHOR-BOLT HOLES: \varnothing 1 1/16"
PLATE THICKNESS: 1/4"
PART NUMBER: 2805

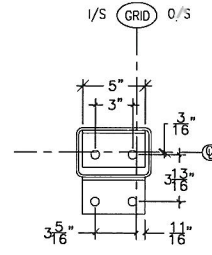

Db 6X4 HEADER / BASE
BD-1 DOOR FRAME

ANCHOR-BOLT HOLES: \varnothing 1 1/16"
PLATE THICKNESS: 1/4"
PART NUMBER: 2407

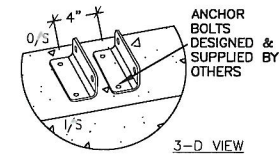

FOUNDATION DESIGNED & SUPPLIED BY OTHERS



TF: 800-407-5846
www.britespanbuildings.com

REV #	CR #	DESCRIPTION	DATE
0		ISSUED FOR CONSTRUCTION	02 AUG 2019

DEALER:
COVER-ALL BUILDINGS OF WV INC.
P.O. BOX 727
BRIDGEPORT, WV. 26330

CUSTOMER:
WV DIVISION OF HIGHWAYS
BURNSVILLE HQTS RT.1 BOX 435
BURNSVILLE, WV. 26335

THIS DRAWING IS PROPERTY OF BRITESPAN BUILDING SYSTEMS INC. ANY REPRODUCTION IN WHOLE OR IN PART WITHOUT THE EXPRESSED WRITTEN CONSENT OF BRITESPAN BUILDING SYSTEMS INC. IS PROHIBITED. THIS DRAWING IS NOT TO SCALE UNLESS OTHERWISE NOTED.

DRAWN BY:
TWF
CHECKED BY:
CJM

PROJECT:
ATLAS 18
40' x 70' - 320 GM
14' oc

ORDER ID:
SO# 6855-01
WIDTH-STEEL-FAB-H/S-HSSDROP:
40-320-220-18-//

DRAWING TITLE:
BASEPLATE DETAILS
SHEET NO.:
BD-1
PAGE NO.:
003 /13

NOTE:
 BUILDING IS DESIGNED AS EXPOSED
 (Ce=0.9) AND PARTIALLY ENCLOSED

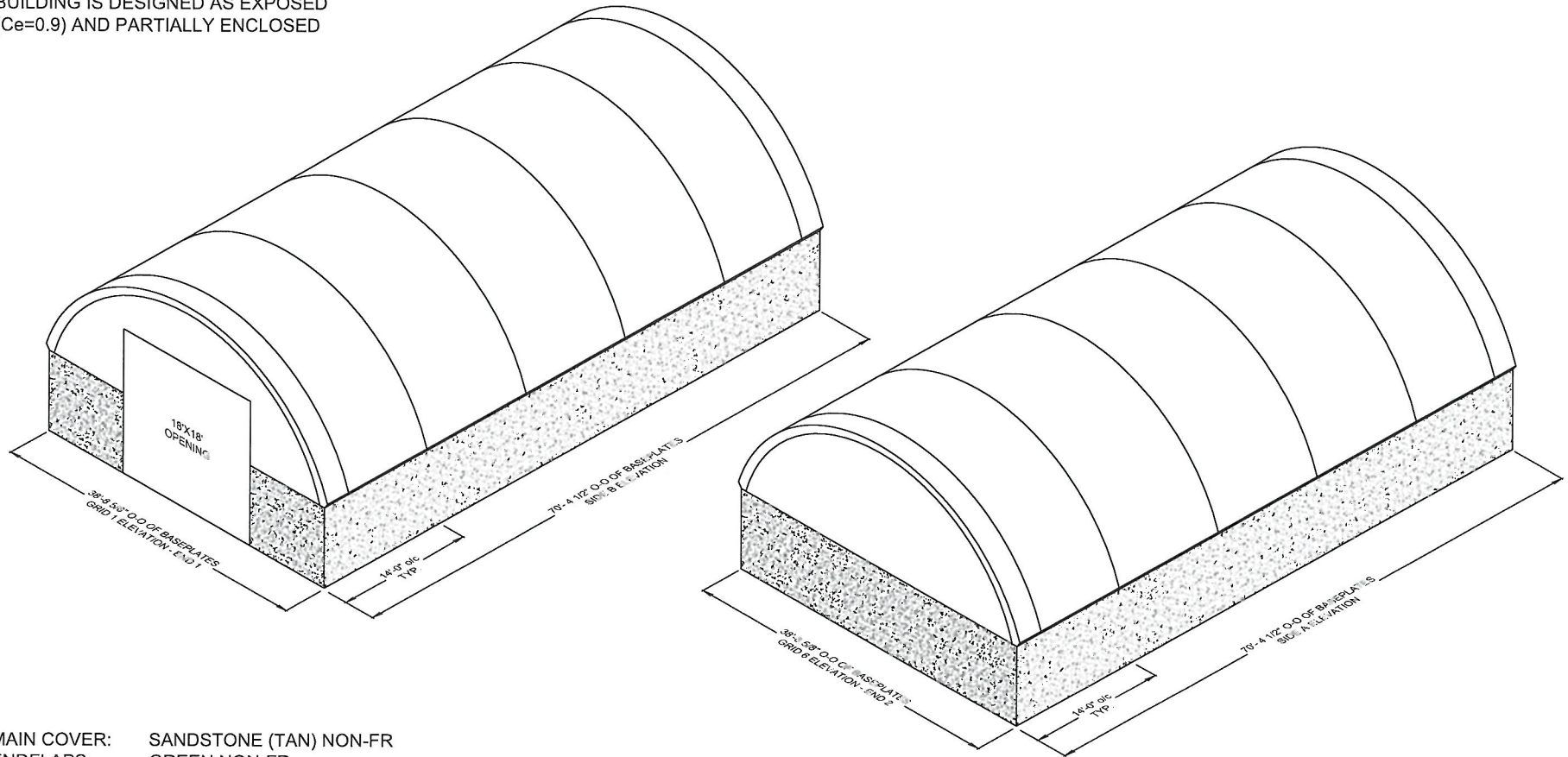

MAIN COVER: SANDSTONE (TAN) NON-FR
 ENDFLAPS: GREEN NON-FR
 ENDWALL(S): SANDSTONE (TAN) NON-FR

FOUNDATION DESIGNED
 & SUPPLIED BY OTHERS

	TF: 800-407-5846 www.britespanbuildings.com	REV #	CR #	DESCRIPTION	DATE	DEALER:	CUSTOMER:	
		0		ISSUED FOR CONSTRUCTION	02 AUG 2019	COVER-ALL BUILDINGS OF WV INC. P.O. BOX 727 BRIDGEPORT, WV. 26330	WV DIVISION OF HIGHWAYS BURNSVILLE HQTS RT.1 BOX 435 BURNSVILLE, WV. 26335	
THIS DRAWING IS PROPERTY OF BRITESPAN BUILDING SYSTEMS INC. ANY REPRODUCTION IN WHOLE OR IN PART WITHOUT THE EXPRESSED WRITTEN CONSENT OF BRITESPAN BUILDING SYSTEMS INC. IS PROHIBITED. THIS DRAWING IS NOT TO SCALE UNLESS OTHERWISE NOTED.	DRAWN BY:					PROJECT:	ORDER ID:	DRAWING TITLE:
	TWF					ATLAS 18 40' x 70' - 320 GM 14' oc	SO# 6855-01	PROJECT LAYOUT
	CHECKED BY:					WIDTH-STEEL-FAB-HSS-HSSDROP:	SHEET NO.:	PAGE NO.:
	CJM					40-320-220-18-//	FB-3	004 /13

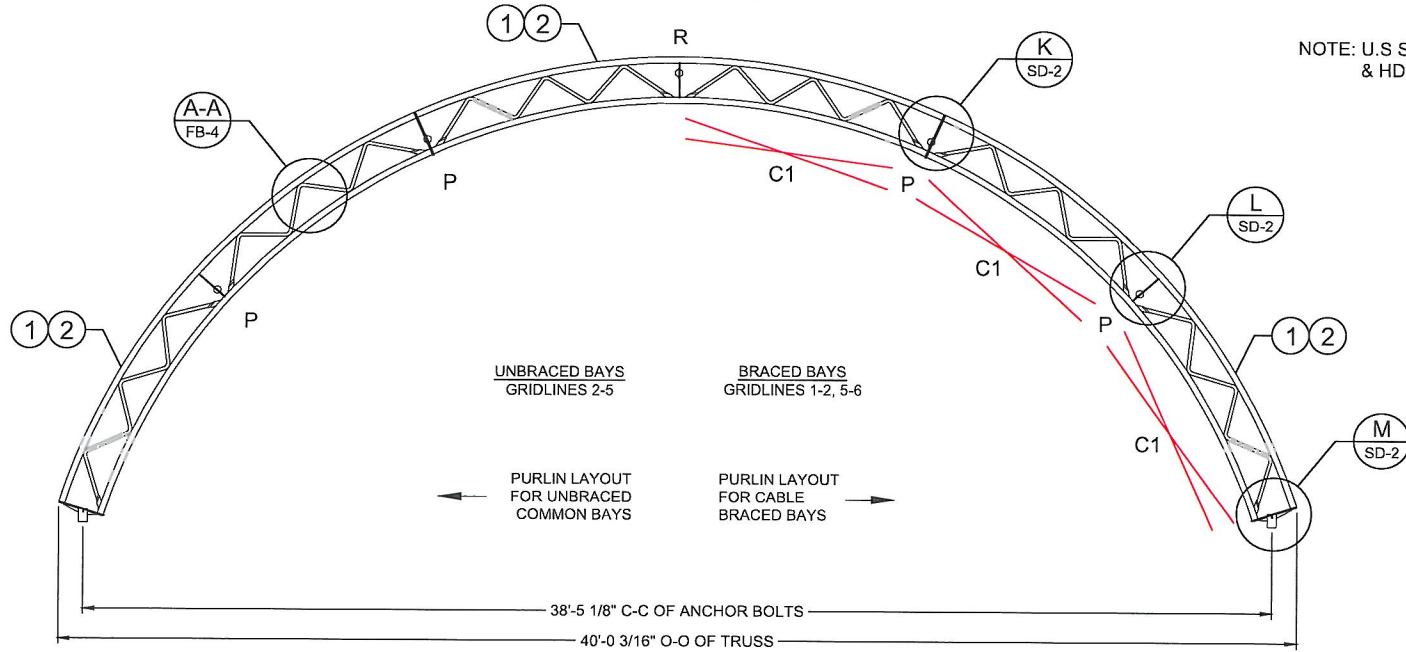

NOTE: U.S STEEL CONTENT & HDG FASTENERS

ATLAS 18 - 40' WIDE

ZERO-TO-ZERO OF BASE PLATES = 54'-4 1/16"

ASSEMBLED TRUSS WEIGHT w/ BASEPLATES ~ 350 lbs (each)

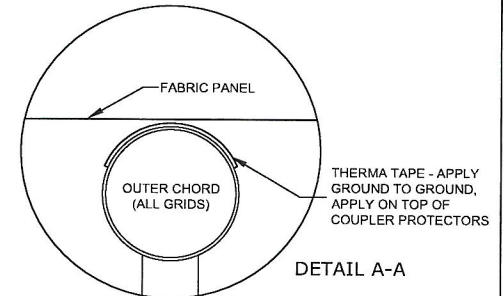

CABLE LEGEND	
ITEM	DESCRIPTION
	CROSS CABLE 5/16"

BRACING LEGEND	
ITEM	DESCRIPTION
X	CROSS CABLE 5/16"
P	PURLIN - 2-7/8" DIA. X 14 GA.
P1	PURLIN - 2-7/8" DIA. X 14 GA.

TRUSS COMPONENTS FOR ATLAS 18 - 40' GM				
LOCATION	ITEM #	PART #	QTY.	DESCRIPTION
INTERIOR	1	104	3	TRUSS - 40' COMMON
END	2	105	3	TRUSS - 40' END

ATLAS 18 40' GM	14' BAY	
	ITEM #	LENGTH
C1 CABLE	861200-9	200"



TF: 800-407-5846
www.britespanbuildings.com

REV #	GR #	DESCRIPTION	DATE
0		ISSUED FOR CONSTRUCTION	02 AUG 2019

DEALER:
COVER-ALL BUILDINGS OF WV INC.
P.O. BOX 727
BRIDGEPORT, WV. 26330

CUSTOMER:
WV DIVISION OF HIGHWAYS
BURNSVILLE HQTS RT.1 BOX 435
BURNSVILLE, WV. 26335

THIS DRAWING IS PROPERTY OF BRITESPAN BUILDING SYSTEMS INC. ANY REPRODUCTION IN WHOLE OR IN PART WITHOUT THE EXPRESSED WRITTEN CONSENT OF BRITESPAN BUILDING SYSTEMS INC. IS PROHIBITED. THIS DRAWING IS NOT TO SCALE UNLESS OTHERWISE NOTED.

DRAWN BY:
TWF
CHECKED BY:
CJM

PROJECT:
ATLAS 18
40' x 70' - 320 GM
14' oc

ORDER ID:
SO# 6855-01
WIDTH-STEEL-FAB-HSS-H³S DROP:
40-320-220-18-//

DRAWING TITLE:
PURLIN & X-CABLE LAYOUT
SHEET NO.:
FB-4
PAGE NO.:
005 / 13

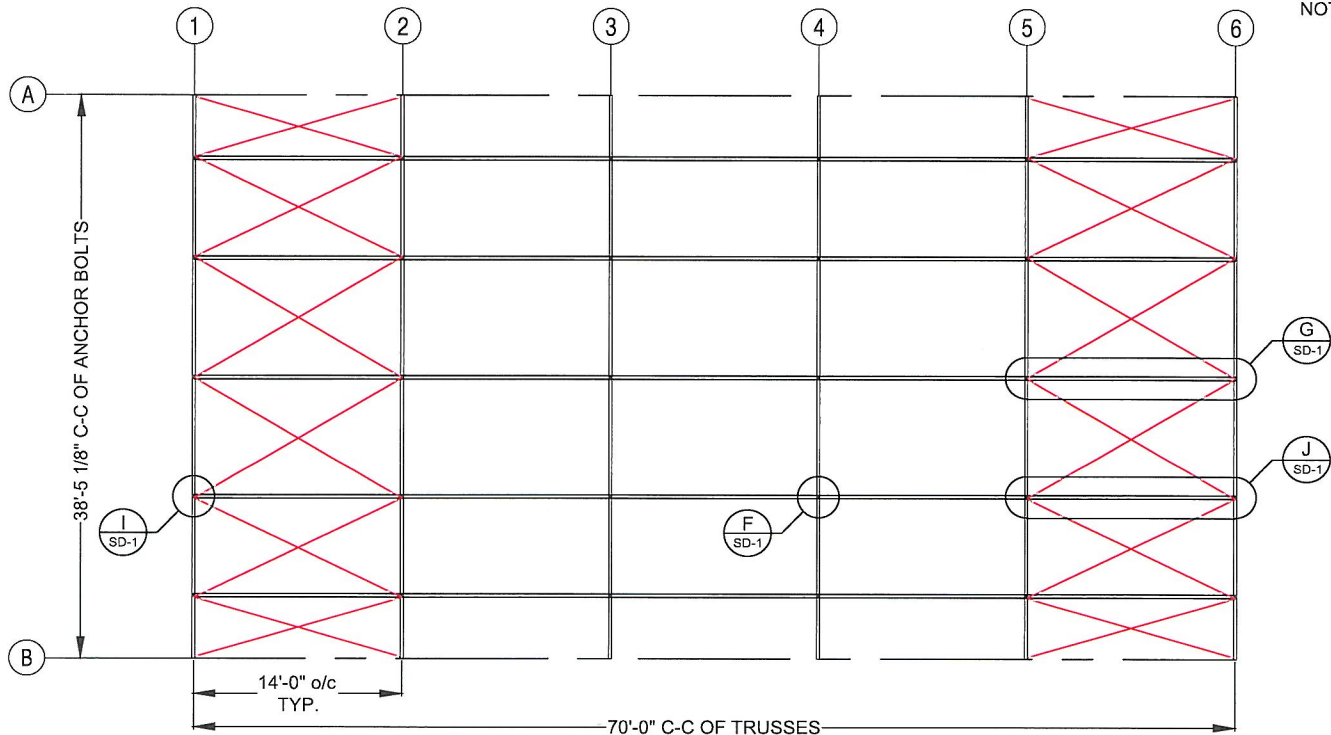

NOTE: U.S STEEL CONTENT
& HDG FASTENERS

PLAN VIEW

FOR PURLIN DETAILS SEE: SD-1
FOR CABLE DETAILS SEE: SD-2

PURLIN LEGEND	
ITEM	DESCRIPTION
	ALL BAYS - PURLINS - 2 7/8" DIA. X 14 GA.

CABLE LEGEND	
ITEM	DESCRIPTION
	CROSS CABLE 5/16"



TF. 800-407-5846
www.britespanbuildings.com

REV #	CR #	DESCRIPTION	DATE
0		ISSUED FOR CONSTRUCTION	02.AUG.2019

DEALER:
COVER-ALL BUILDINGS OF WV INC.
P.O. BOX 727
BRIDGEPORT, WV. 26330

CUSTOMER:
WV DIVISION OF HIGHWAYS
BURNSVILLE HQTS RT.1 BOX 435
BURNSVILLE, WV. 26335

THIS DRAWING IS PROPERTY OF BRITESPAN BUILDING SYSTEMS INC.. ANY REPRODUCTION IN WHOLE OR IN PART WITHOUT THE EXPRESSED WRITTEN CONSENT OF BRITESPAN BUILDING SYSTEMS INC. IS PROHIBITED. THIS DRAWING IS NOT TO SCALE UNLESS OTHERWISE NOTED.

DRAWN BY:
TWF
CHECKED BY:
CJM

PROJECT:
ATLAS 18
40' x 70' - 320 GM
14' oc

ORDER ID:
SO# 6855-01
WIDTH-STEEL-FAB-HSS-HSSDROP
40-320-220-18-//

DRAWING TITLE:
BRACING LAYOUT - PLAN VIEW
SHEET NO.: FB-5
PAGE NO.: 006 /13

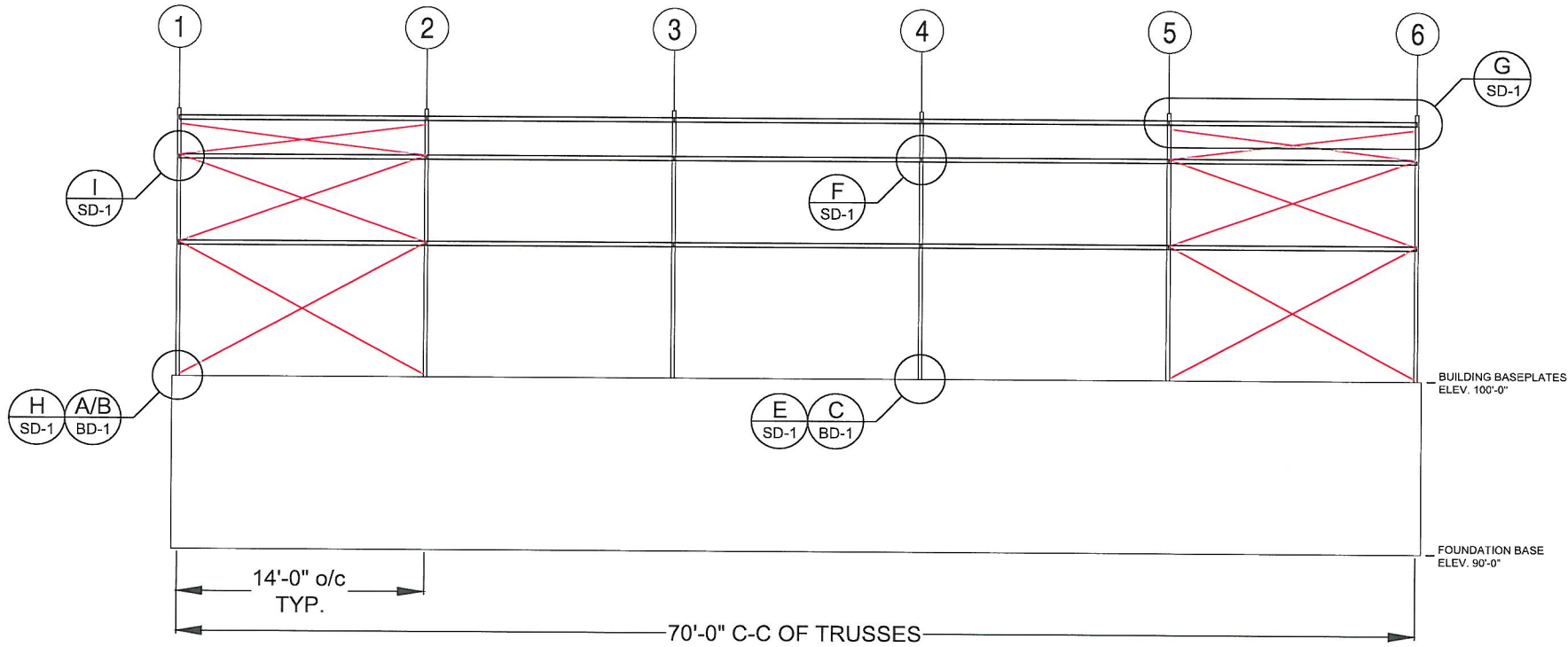

ELEVATION

NOTE: U.S STEEL CONTENT
& HDG FASTENERS

FOR PURLIN DETAILS SEE: SD-1

FOR CABLE DETAILS SEE: SD-2

PURLIN LEGEND	
ITEM	DESCRIPTION
	ALL BAYS - PURLINS - 2 7/8" DIA. X 14 GA.

CABLE LEGEND	
ITEM	DESCRIPTION
	CROSS CABLE 5/16"



TF: 800-407-5846
www.britespanbuildings.com

REV #	CR #	DESCRIPTION	DATE
0		ISSUED FOR CONSTRUCTION	02.AUG.2019

DEALER:
COVER-ALL BUILDINGS OF WV INC.
P.O. BOX 727
BRIDGEPORT, WV. 26330

CUSTOMER:
WV DIVISION OF HIGHWAYS
BURNSVILLE HQTS RT.1 BOX 435
BURNSVILLE, WV. 26335

THIS DRAWING IS PROPERTY OF BRITESPAN BUILDING SYSTEMS INC. ANY REPRODUCTION IN WHOLE OR IN PART WITHOUT THE EXPRESSED WRITTEN CONSENT OF BRITESPAN BUILDING SYSTEMS INC. IS PROHIBITED. THIS DRAWING IS NOT TO SCALE UNLESS OTHERWISE NOTED.

DRAWN BY:
TWF
CHECKED BY:
CJM

PROJECT:
ATLAS 18
40' x 70' - 320 GM
14' oc

ORDER ID:
SO# 6855-01
WIDTH-STEEL-FAB-HSS-HS-DROP:
40-320-220-18-II

DRAWING TITLE:
BRACING LAYOUT - ELEVATION
SHEET NO.: FB-6
PAGE NO.: 007 /13

NOTES:

1. "H" DENOTES BLOCK WINCH & STRAP FOR FASTENING TUBE
2. EC VERTICAL LOCATION DIMENSIONS ARE TO THE CENTRELINE OF MEMBERS
3. FIELD DRILL HSS AS REQUIRED
4. FINAL FABRIC TERMINATION DESIGNED & SUPPLIED BY OTHERS FOR ALL APRONS

MARK #	QTY.	COMPONENTS (in)
EC-1	2	2408- HSS- VERTICAL- 4" X 6" X 3/16"- 3" CENTRES- 136"
161	4	BRKT- 6" DEEP HSS TOP SADDLE- 2-3/8" CHORD
2407	12	HEADER/ BASE ANGLE- 4" X 6" HSS - 3" CENTRES
HD-1	1	2409- HSS- HEADER- 4" X 6" X 3/16"- 3" CENTRES- 215"
HD-2	2	2409- HSS- HEADER- 4" X 6" X 3/16"- 3" CENTRES- 120"

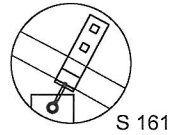

S 161

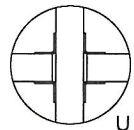

U 2407

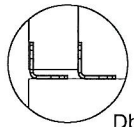

Db 2407

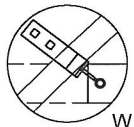

W 161

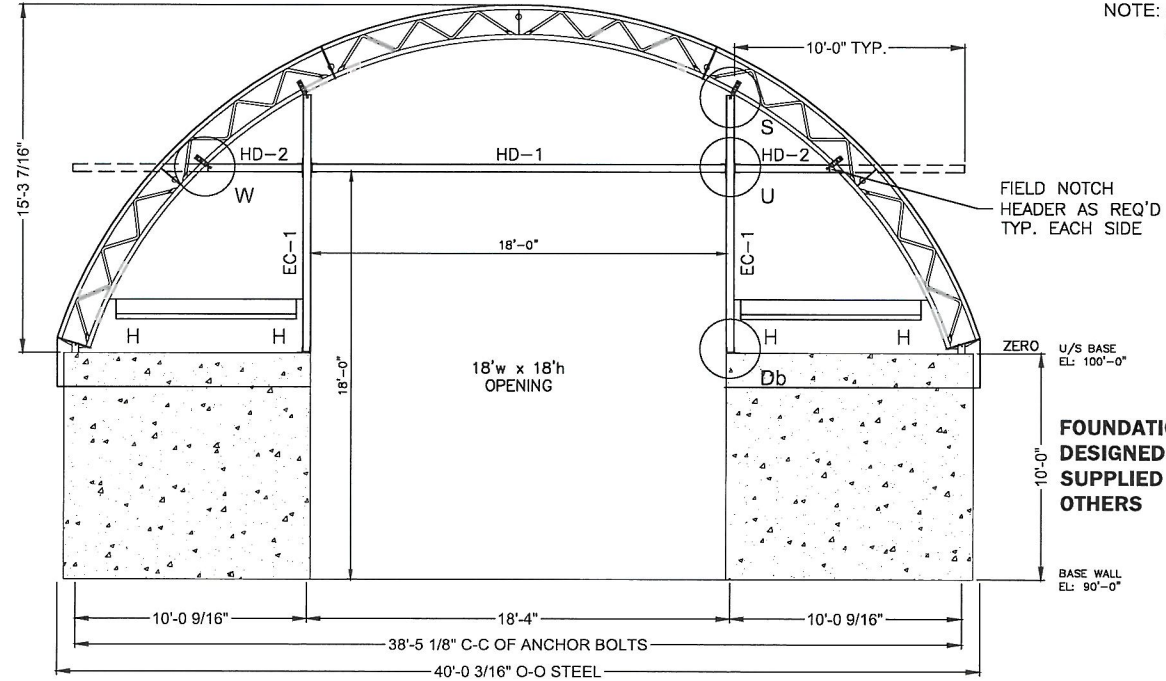

NOTE: U.S STEEL CONTENT & HDG FASTENERS

FIELD NOTCH HEADER AS REQ'D TYP. EACH SIDE

ZERO U/S BASE EL: 100'-0"

FOUNDATION DESIGNED & SUPPLIED BY OTHERS

BASE WALL EL: 90'-0"

GRIDLINE 1 - END 1



TF: 800-407-5846
www.britespanbuildings.com

REV #	CR #	DESCRIPTION	DATE
0		ISSUED FOR CONSTRUCTION	02.AUG.2019

DEALER:
COVER-ALL BUILDINGS OF WV INC.
P.O. BOX 727
BRIDGEPORT, WV. 26330

CUSTOMER:
WV DIVISION OF HIGHWAYS
BURNSVILLE HQTS RT.1 BOX 435
BURNSVILLE, WV. 26335

THIS DRAWING IS PROPERTY OF BRITESPAN BUILDING SYSTEMS INC.. ANY REPRODUCTION IN WHOLE OR IN PART WITHOUT THE EXPRESSED WRITTEN CONSENT OF BRITESPAN BUILDING SYSTEMS INC. IS PROHIBITED. THIS DRAWING IS NOT TO SCALE UNLESS OTHERWISE NOTED.

DRAWN BY:
TWF
CHECKED BY:
CJM

PROJECT:
ATLAS 18
40' x 70' - 320 GM
14' oc

ORDER ID:
SO# 6855-01
WIDTH-STEEL FAB-HSS-HSSDROP:
40-320-220-18-//

DRAWING TITLE:
ENDWALL 1 LAYOUT
SHEET NO.:
EW-1
PAGE NO.:
008 /13

NOTES:

1. "H" DENOTES BLOCK WINCH & STRAP FOR FASTENING TUBE
2. EC VERTICAL LOCATION DIMENSIONS ARE TO THE CENTRELINE OF MEMBERS
3. FIELD DRILL HSS AS REQUIRED
4. FIELD CUT CEE CHANNEL AS REQUIRED

MARK #	QTY.	COMPONENTS (in)
EC-1	2	1518-HSS- VERTICAL- 4" X 4" X 1/8"- 2" CENTRES - 136"
160	2	BRKT- 4" DEEP HSS TOP SADDLE- 2-3/8" CHORD
2805	4	HEADER/ BASE ANGLE- 4" X 4" HSS - 2" CENTRES
HZ-1/201	2	1538-240- CEE CHANNEL 6" - 14 ga - 240"/6096mm
HZ-1/200	1	1538-180- CEE CHANNEL 6" - 14 ga - 180"/4572mm
194	8	BRKT - CEE CHANNEL ANGLE

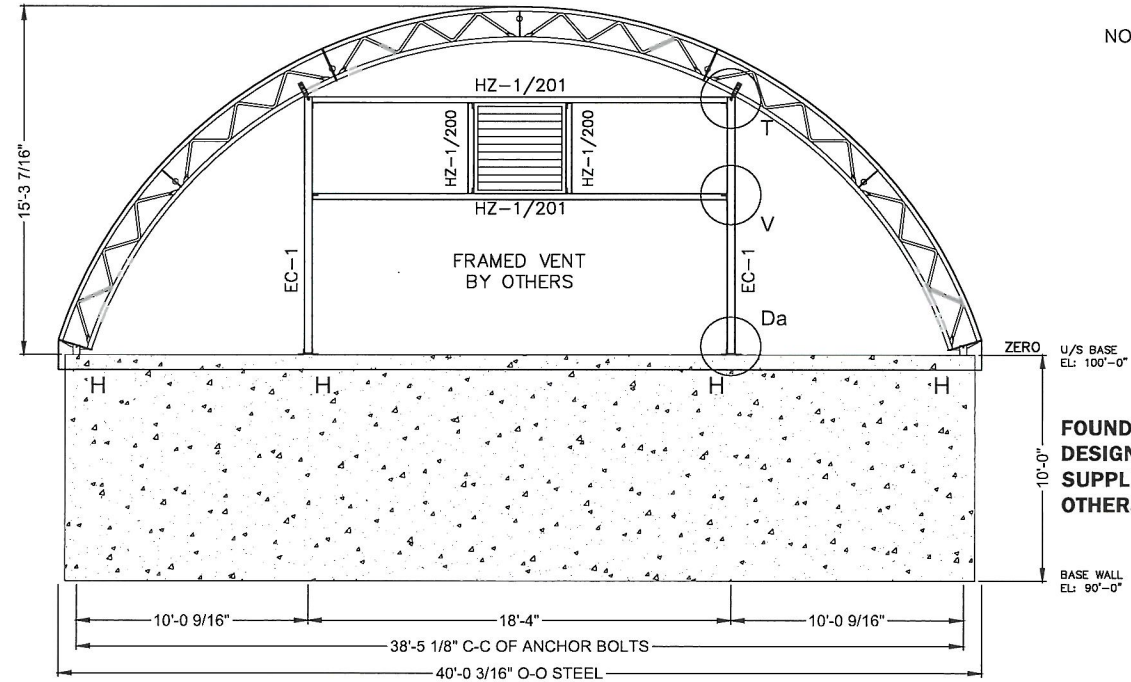
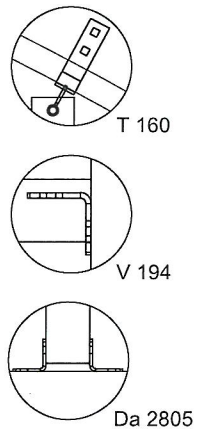

NOTE: U.S STEEL CONTENT & HDG FASTENERS

FOUNDATION DESIGNED & SUPPLIED BY OTHERS

GRIDLINE 6 - END 2

<p>TF: 800-407-5846 www.britespanbuildings.com</p>	<table border="1"> <thead> <tr> <th>REV #</th> <th>CR #</th> <th>DESCRIPTION</th> <th>DATE</th> </tr> </thead> <tbody> <tr> <td>0</td> <td></td> <td>ISSUED FOR CONSTRUCTION</td> <td>02.AUG.2019</td> </tr> </tbody> </table>	REV #	CR #	DESCRIPTION	DATE	0		ISSUED FOR CONSTRUCTION	02.AUG.2019	<p>DEALER:</p> <p>COVER-ALL BUILDINGS OF WV INC. P.O. BOX 727 BRIDGEPORT, WV. 26330</p>	<p>CUSTOMER:</p> <p>WV DIVISION OF HIGHWAYS BURNSVILLE HQTS RT.1 BOX 435 BURNSVILLE, WV. 26335</p>				
	REV #	CR #	DESCRIPTION	DATE											
0		ISSUED FOR CONSTRUCTION	02.AUG.2019												
<p>THIS DRAWING IS PROPERTY OF BRITESPAN BUILDING SYSTEMS INC. ANY REPRODUCTION IN WHOLE OR IN PART WITHOUT THE EXPRESSED WRITTEN CONSENT OF BRITESPAN BUILDING SYSTEMS INC. IS PROHIBITED. THIS DRAWING IS NOT TO SCALE UNLESS OTHERWISE NOTED.</p>	<p>DRAWN BY:</p> <p>TWF</p> <p>CHECKED BY:</p> <p>CJM</p>	<p>PROJECT:</p> <p>ATLAS 18 40' x 70' - 320 GM 14' oc</p>	<table border="1"> <tr> <td>ORDER ID:</td> <td>SO# 6855-01</td> <td>DRAWING TITLE:</td> <td>ENDWALL 2 LAYOUT</td> </tr> <tr> <td>WIDTH-STEEL-FAB-HSS-HSSDROP:</td> <td>40-320-220-18-//</td> <td>SHEET NO.:</td> <td>EW-2</td> </tr> <tr> <td></td> <td></td> <td>PAGE NO.:</td> <td>009 /13</td> </tr> </table>	ORDER ID:	SO# 6855-01	DRAWING TITLE:	ENDWALL 2 LAYOUT	WIDTH-STEEL-FAB-HSS-HSSDROP:	40-320-220-18-//	SHEET NO.:	EW-2			PAGE NO.:	009 /13
ORDER ID:	SO# 6855-01	DRAWING TITLE:	ENDWALL 2 LAYOUT												
WIDTH-STEEL-FAB-HSS-HSSDROP:	40-320-220-18-//	SHEET NO.:	EW-2												
		PAGE NO.:	009 /13												

NOTE: U.S STEEL CONTENT
& HDG FASTENERS

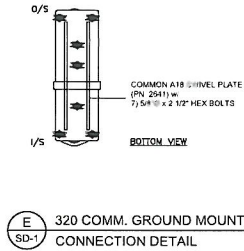
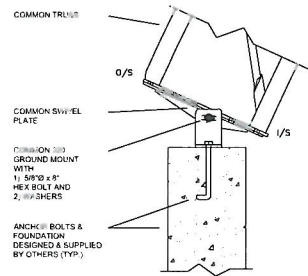

E 320 COMM. GROUND MOUNT CONNECTION DETAIL
SD-1

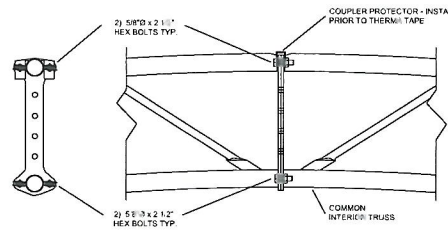

F COMMON TRUSS CONNECTION DETAIL
SD-1

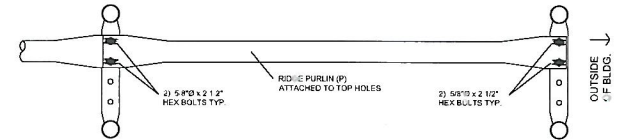

G RIDGE PURLIN w/KING PIN CONNECTION DETAIL
SD-1

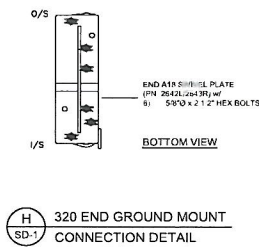
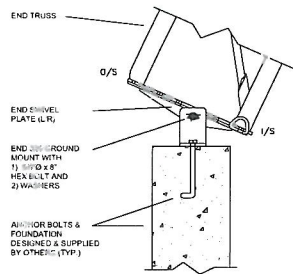

H 320 END GROUND MOUNT CONNECTION DETAIL
SD-1

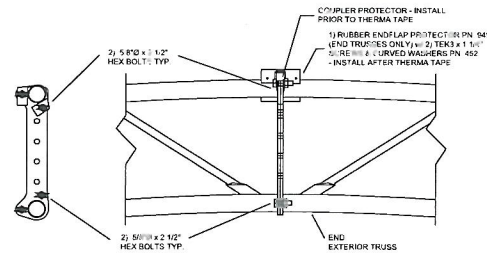

I END TRUSS CONNECTION DETAIL
SD-1

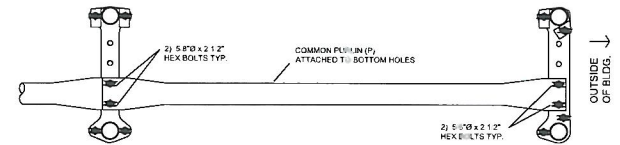

J COMMON PURLIN CONNECTION DETAIL
SD-1

 <p>TF: 800-407-5846 www.britespanbuildings.com</p>	<table border="1"> <thead> <tr> <th>REV #</th> <th>CR #</th> <th>DESCRIPTION</th> <th>DATE</th> </tr> </thead> <tbody> <tr> <td>0</td> <td></td> <td>ISSUED FOR CONSTRUCTION</td> <td>02.AUG.2019</td> </tr> <tr> <td> </td> <td> </td> <td> </td> <td> </td> </tr> <tr> <td> </td> <td> </td> <td> </td> <td> </td> </tr> <tr> <td> </td> <td> </td> <td> </td> <td> </td> </tr> <tr> <td> </td> <td> </td> <td> </td> <td> </td> </tr> </tbody> </table>	REV #	CR #	DESCRIPTION	DATE	0		ISSUED FOR CONSTRUCTION	02.AUG.2019																	<p>DEALER: COVER-ALL BUILDINGS OF WV INC. P.O. BOX 727 BRIDGEPORT, WV. 26330</p>	<p>CUSTOMER: WV DIVISION OF HIGHWAYS BURNSVILLE HQTS RT.1 BOX 435 BURNSVILLE, WV. 26335</p>
	REV #	CR #	DESCRIPTION	DATE																							
0		ISSUED FOR CONSTRUCTION	02.AUG.2019																								
<p>THIS DRAWING IS PROPERTY OF BRITESPAN BUILDING SYSTEMS INC.. ANY REPRODUCTION IN WHOLE OR IN PART WITHOUT THE EXPRESSED WRITTEN CONSENT OF BRITESPAN BUILDING SYSTEMS INC. IS PROHIBITED. THIS DRAWING IS NOT TO SCALE UNLESS OTHERWISE NOTED.</p>	<p>DRAWN BY: TWF</p> <p>CHECKED BY: CJM</p>	<p>PROJECT: ATLAS 18 40' x 70' - 320 GM 14' oc</p>	<p>ORDER ID: SO# 6855-01</p> <p>WIDTH-STEEL-FAB-HSS-HSSDROP: 40-320-220-18-//</p>	<p>DRAWING TITLE: STANDARD DETAILS 1</p> <p>SHEET NO.: SD-1</p> <p>PAGE NO.: 010 /13</p>																							

NOTE: U.S STEEL CONTENT
& HDG FASTENERS

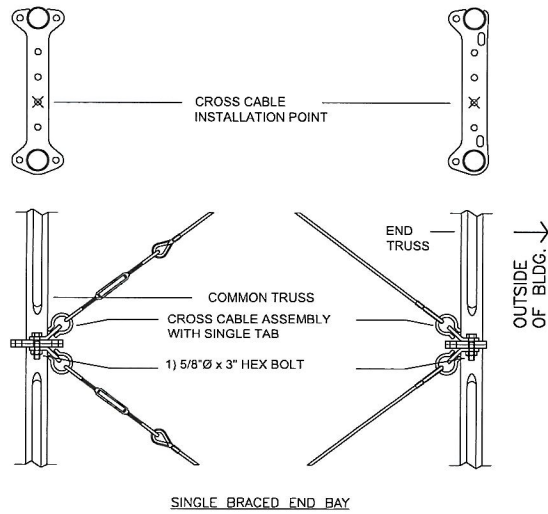

K CROSS CABLES AT DOGBONE
SD-2 CONNECTION DETAILS

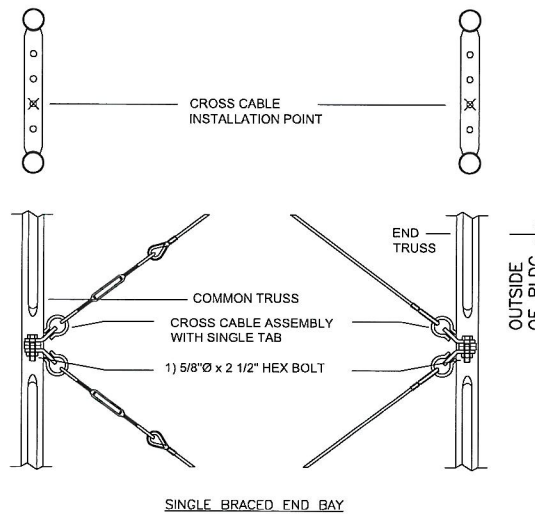

L CROSS CABLES AT KINGPIN
SD-2 CONNECTION DETAILS

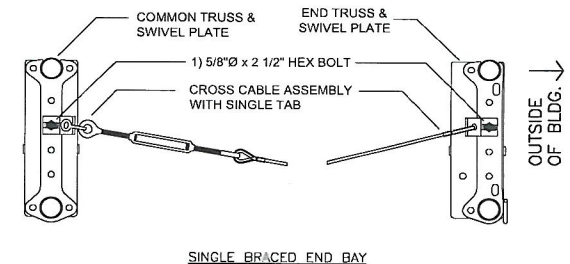

M CROSS CABLES AT SWIVEL PLATE
SD-2 CONNECTION DETAILS



TF: 800-407-5846
www.britespanbuildings.com

REV #	CR #	DESCRIPTION	DATE
0		ISSUED FOR CONSTRUCTION	02 AUG 2019

DEALER: COVER-ALL BUILDINGS OF WV INC. P.O. BOX 727 BRIDGEPORT, WV. 26330	CUSTOMER: WV DIVISION OF HIGHWAYS BURNSVILLE HQTS RT.1 BOX 435 BURNSVILLE, WV. 26335
PROJECT: ATLAS 18 40' x 70' - 320 GM 14' oc	ORDER ID: SO# 6855-01

WIDTH-STEEL-FAB-HSS-HSSDROP: 40-320-220-18-//	DRAWING TITLE: STANDARD DETAILS 2
SHEET NO.: SD-2	PAGE NO.: 011 /13

THIS DRAWING IS PROPERTY OF BRITESPAN BUILDING SYSTEMS INC.. ANY REPRODUCTION IN WHOLE OR IN PART WITHOUT THE EXPRESSED WRITTEN CONSENT OF BRITESPAN BUILDING SYSTEMS INC. IS PROHIBITED. THIS DRAWING IS NOT TO SCALE UNLESS OTHERWISE NOTED.

DRAWN BY:
TWF
CHECKED BY:
CJM

NOTE: U.S STEEL CONTENT
& HDG FASTENERS

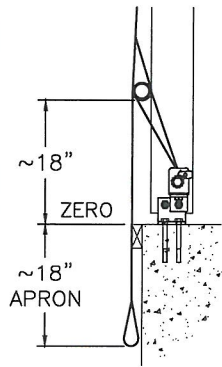

(N) SD-3 ENDWALL #1 TERMINATION CONNECTION DETAIL

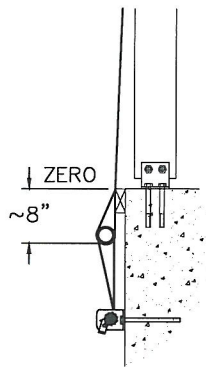

(O) SD-3 ENDWALL #2 TERMINATION CONNECTION DETAIL

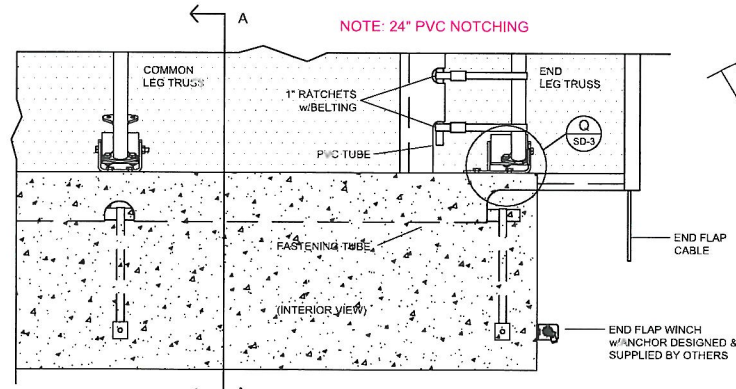

(P) SD-3 220 STANDARD COVER CONNECTION DETAIL

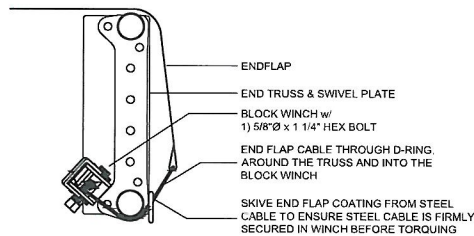

(Q) SD-3 END FLAP CABLE & WINCH CONNECTION DETAIL

NOTE: ENDFLAP WINCH CAN ALSO BE INSTALLED ON FRONT FACE OF FOUNDATION AS SHOWN IN P / SD-3.

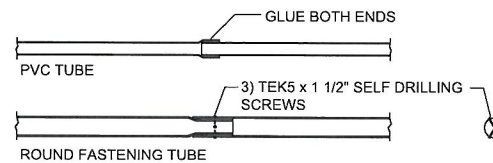

(R) SD-3 PVC/FASTENING TUBE CONNECTION DETAIL

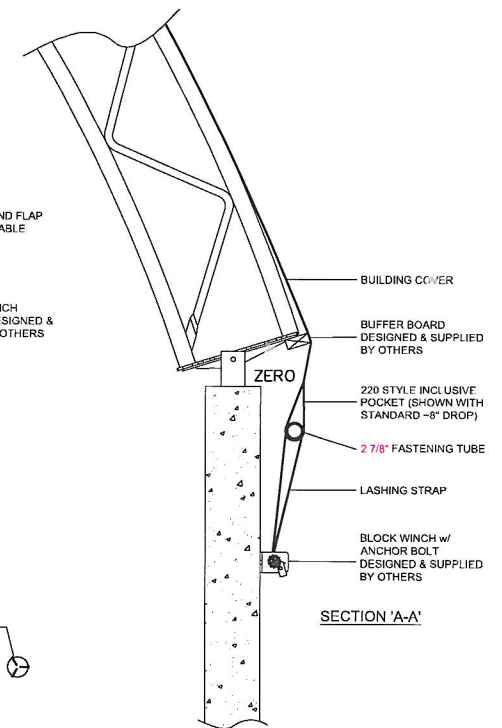

SECTION 'A-A'



TF: 800-407-5846
www.britespanbuildings.com

REV #	CR #	DESCRIPTION	DATE
0		ISSUED FOR CONSTRUCTION	02.AUG.2019

DEALER:
COVER-ALL BUILDINGS OF WV INC.
P.O. BOX 727
BRIDGEPORT, WV. 26330

CUSTOMER:
WV DIVISION OF HIGHWAYS
BURNSVILLE HQTS RT.1 BOX 435
BURNSVILLE, WV. 26335

THIS DRAWING IS PROPERTY OF BRITESPAN BUILDING SYSTEMS INC. ANY REPRODUCTION IN WHOLE OR IN PART WITHOUT THE EXPRESSED WRITTEN CONSENT OF BRITESPAN BUILDING SYSTEMS INC. IS PROHIBITED. THIS DRAWING IS NOT TO SCALE UNLESS OTHERWISE NOTED.

DRAWN BY:
TWF
CHECKED BY:
CJM

PROJECT:
ATLAS 18
40' x 70' - 320 GM
14' oc

ORDER ID:
SO# 6855-01
WIDTH-STEEL-FAB-HES-HSSDROP:
40-320-220-18-11

DRAWING TITLE:
STANDARD DETAILS 3
SHEET NO.:
SD-3
PAGE NO.:
012 / 113

NOTE: U.S STEEL CONTENT
& HDG FASTENERS

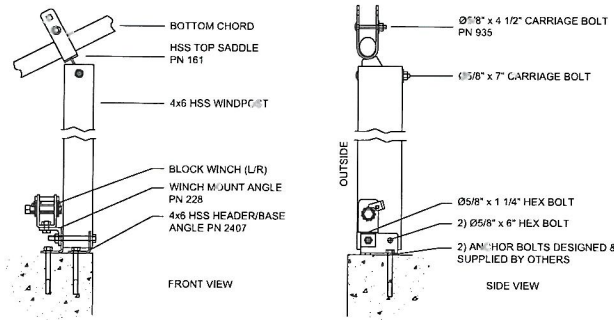

Db **S** 6x4 HSS WINDPOST - 2 3/8" CHORD
BD-1 **ED-1** CONNECTION DETAILS

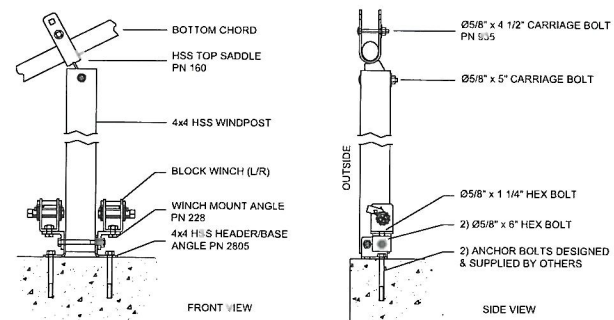

Da **T** 4x4 HSS WINDPOST - 2 3/8" CHORD
BD-1 **ED-1** CONNECTION DETAILS

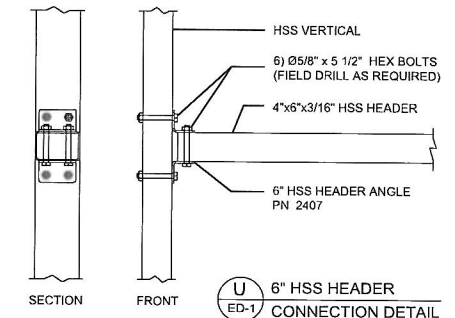

U 6" HSS HEADER
ED-1 CONNECTION DETAIL

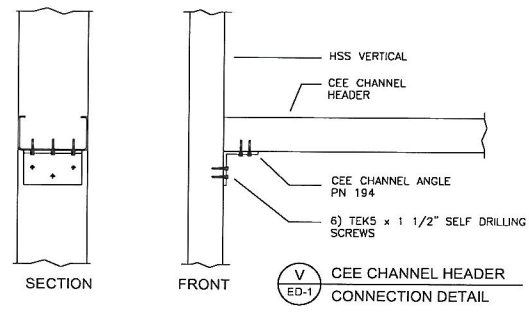

V CEE CHANNEL HEADER
ED-1 CONNECTION DETAIL

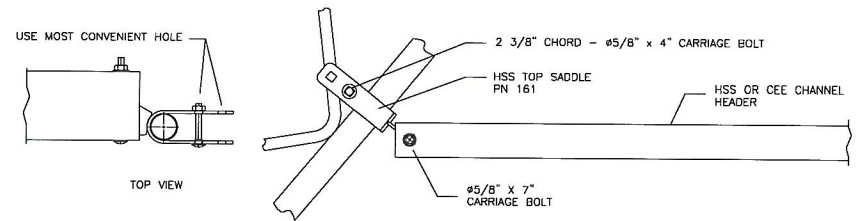

W HEADER / CEE CHANNEL TO TRUSS
ED-1 CONNECTION DETAIL



TF: 800-407-5846
www.britespanbuildings.com

REV #	CR #	DESCRIPTION	DATE
0		ISSUED FOR CONSTRUCTION	02.AUG.2019

DEALER:
COVER-ALL BUILDINGS OF WV INC.
P.O. BOX 727
BRIDGEPORT, WV. 26330

CUSTOMER:
WV DIVISION OF HIGHWAYS
BURNSVILLE HQTS RT.1 BOX 435
BURNSVILLE, WV. 26335

THIS DRAWING IS PROPERTY OF BRITESPAN BUILDING SYSTEMS INC. ANY REPRODUCTION IN WHOLE OR IN PART WITHOUT THE EXPRESSED WRITTEN CONSENT OF BRITESPAN BUILDING SYSTEMS INC. IS PROHIBITED. THIS DRAWING IS NOT TO SCALE UNLESS OTHERWISE NOTED.

DRAWN BY:
TWF
CHECKED BY:
CJM

PROJECT:
ATLAS 18
40' x 70' - 320 GM
14' oc

ORDER ID:
SO# 6855-01
WIDTH-STEEL-FAB-HSS-HSSDROP
40-320-220-18-II

DRAWING TITLE:
ENDWALL DETAILS
SHEET NO.:
ED-1
PAGE NO.:
013 /13

BID BOND

KNOW ALL MEN BY THESE PRESENTS, That we, the undersigned, R & T Enterprises, Inc.
of Bridgeport, WV, as Principal, and Western Surety Company
of Chicago, IL, a corporation organized and existing under the laws of the State of
SD with its principal office in the City of Chicago, as Surety, are held and firmly bound unto the State
of West Virginia, as Obligee, in the penal sum of Five Percent of Amount Bid (\$ 5%) for the payment of which,
well and truly to be made, we jointly and severally bind ourselves, our heirs, administrators, executors, successors and assigns.

The Condition of the above obligation is such that whereas the Principal has submitted to the Purchasing Section of the
Department of Administration a certain bid or proposal, attached hereto and made a part hereof, to enter into a contract in writing for
WVDOH Sugar Grove Salt Shed - Roofing System

NOW THEREFORE,

- (a) If said bid shall be rejected, or
- (b) If said bid shall be accepted and the Principal shall enter into a contract in accordance with the bid or proposal
attached hereto and shall furnish any other bonds and insurance required by the bid or proposal, and shall in all other respects perform
the agreement created by the acceptance of said bid, then this obligation shall be null and void, otherwise this obligation shall remain in
full force and effect. It is expressly understood and agreed that the liability of the Surety for any and all claims hereunder shall, in no
event, exceed the penal amount of this obligation as herein stated.

The Surety, for the value received, hereby stipulates and agrees that the obligations of said Surety and its bond shall be in no
way impaired or affected by any extension of the time within which the Obligee may accept such bid, and said Surety does hereby
waive notice of any such extension.

WITNESS, the following signatures and seals of Principal and Surety, executed and sealed by a proper officer of Principal and
Surety, or by Principal individually if Principal is an individual, this 17th day of August, 2021.

Principal Seal

R & T Enterprises, Inc. Nathaniel G. Robrig
(Name of Principal)
By: [Signature]
(Must be President, Vice President, or
Duly Authorized Agent)
President
(Title)

Surety Seal

Western Surety Company
(Name of Surety)
By: [Signature]
Kimberly L. Miles Licensed WV Resident Agent Attorney-in-Fact

**IMPORTANT – Surety executing bonds must be licensed in West Virginia to transact surety insurance, must affix its seal, and
must attach a power of attorney with its seal affixed.**

Western Surety Company

POWER OF ATTORNEY APPOINTING INDIVIDUAL ATTORNEY-IN-FACT

Know All Men By These Presents, That WESTERN SURETY COMPANY, a South Dakota corporation, is a duly organized and existing corporation having its principal office in the City of Sioux Falls, and State of South Dakota, and that it does by virtue of the signature and seal herein affixed hereby make, constitute and appoint

Andrew K Teeter, Kimberly L Miles, Douglas P Taylor, Kimberly S Burdette, Jaime L Carpenter, Individually

of Charleston, WV, its true and lawful Attorney(s)-in-Fact with full power and authority hereby conferred to sign, seal and execute for and on its behalf bonds, undertakings and other obligatory instruments of similar nature

- In Unlimited Amounts -

and to bind it thereby as fully and to the same extent as if such instruments were signed by a duly authorized officer of the corporation and all the acts of said Attorney, pursuant to the authority hereby given, are hereby ratified and confirmed.

This Power of Attorney is made and executed pursuant to and by authority of the By-Law printed on the reverse hereof, duly adopted, as indicated, by the shareholders of the corporation.

In Witness Whereof, WESTERN SURETY COMPANY has caused these presents to be signed by its Vice President and its corporate seal to be hereto affixed on this 5th day of April, 2016.

WESTERN SURETY COMPANY



Paul T. Bruflat
Paul T. Bruflat, Vice President

State of South Dakota }
County of Minnehaha } ss

On this 5th day of April, 2016, before me personally came Paul T. Bruflat, to me known, who, being by me duly sworn, did depose and say: that he resides in the City of Sioux Falls, State of South Dakota; that he is the Vice President of WESTERN SURETY COMPANY described in and which executed the above instrument; that he knows the seal of said corporation; that the seal affixed to the said instrument is such corporate seal; that it was so affixed pursuant to authority given by the Board of Directors of said corporation and that he signed his name thereto pursuant to like authority, and acknowledges same to be the act and deed of said corporation.

My commission expires
June 23, 2021

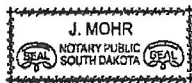

J. Mohr
J. Mohr, Notary Public

CERTIFICATE

I, L. Nelson, Assistant Secretary of WESTERN SURETY COMPANY do hereby certify that the Power of Attorney hereinabove set forth is still in force, and further certify that the By-Law of the corporation printed on the reverse hereof is still in force. In testimony whereof I have hereunto subscribed my name and affixed the seal of the said corporation this 17th day of August, 2021.



WESTERN SURETY COMPANY

L. Nelson
L. Nelson, Assistant Secretary

STATE OF WEST VIRGINIA
Purchasing Division

PURCHASING AFFIDAVIT

CONSTRUCTION CONTRACTS: Under W. Va. Code § 5-22-1(i), the contracting public entity shall not award a construction contract to any bidder that is known to be in default on any monetary obligation owed to the state or a political subdivision of the state, including, but not limited to, obligations related to payroll taxes, property taxes, sales and use taxes, fire service fees, or other fines or fees.

ALL CONTRACTS: Under W. Va. Code §5A-3-10a, no contract or renewal of any contract may be awarded by the state or any of its political subdivisions to any vendor or prospective vendor when the vendor or prospective vendor or a related party to the vendor or prospective vendor is a debtor and: (1) the debt owed is an amount greater than one thousand dollars in the aggregate; or (2) the debtor is in employer default.

EXCEPTION: The prohibition listed above does not apply where a vendor has contested any tax administered pursuant to chapter eleven of the W. Va. Code, workers' compensation premium, permit fee or environmental fee or assessment and the matter has not become final or where the vendor has entered into a payment plan or agreement and the vendor is not in default of any of the provisions of such plan or agreement.

DEFINITIONS:

"Debt" means any assessment, premium, penalty, fine, tax or other amount of money owed to the state or any of its political subdivisions because of a judgment, fine, permit violation, license assessment, defaulted workers' compensation premium, penalty or other assessment presently delinquent or due and required to be paid to the state or any of its political subdivisions, including any interest or additional penalties accrued thereon.

"Employer default" means having an outstanding balance or liability to the old fund or to the uninsured employers' fund or being in policy default, as defined in W. Va. Code § 23-2c-2, failure to maintain mandatory workers' compensation coverage, or failure to fully meet its obligations as a workers' compensation self-insured employer. An employer is not in employer default if it has entered into a repayment agreement with the Insurance Commissioner and remains in compliance with the obligations under the repayment agreement.

"Related party" means a party, whether an individual, corporation, partnership, association, limited liability company or any other form or business association or other entity whatsoever, related to any vendor by blood, marriage, ownership or contract through which the party has a relationship of ownership or other interest with the vendor so that the party will actually or by effect receive or control a portion of the benefit, profit or other consideration from performance of a vendor contract with the party receiving an amount that meets or exceeds five percent of the total contract amount.

AFFIRMATION: By signing this form, the vendor's authorized signer affirms and acknowledges under penalty of law for false swearing (W. Va. Code §61-5-3) that: (1) for construction contracts, the vendor is not in default on any monetary obligation owed to the state or a political subdivision of the state, and (2) for all other contracts, that neither vendor nor any related party owe a debt as defined above and that neither vendor nor any related party are in employer default as defined above, unless the debt or employer default is permitted under the exception above.

WITNESS THE FOLLOWING SIGNATURE:

Vendor's Name: Red Enterprises, Inc.

Authorized Signature: [Signature] Date: 8-30-2021

State of WV

County of Harrison, to-wit:

Taken, subscribed, and sworn to before me this 30 day of August, 2021.

My Commission expires November 17, 2025

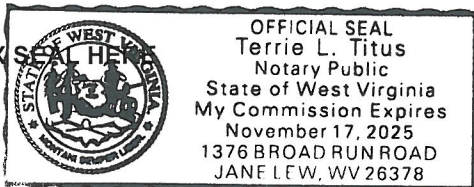

NOTARY PUBLIC [Signature]



**State of West Virginia
DRUG FREE WORKPLACE CONFORMANCE AFFIDAVIT
West Virginia Code §21-1D-5**

I, Nathaniel G. Risher, after being first duly sworn, depose and state as follows:

1. I am an employee of RHT Enterprises, Inc.; and,
(Company Name)
2. I do hereby attest that RHT Enterprises, Inc.
(Company Name)

maintains a written plan for a drug-free workplace policy and that such plan and policy are in compliance with **West Virginia Code §21-1D**.

The above statements are sworn to under the penalty of perjury.

Printed Name: Nathaniel G. Risher
 Signature: [Handwritten Signature]
 Title: President
 Company Name: RHT Enterprises, Inc.
 Date: 8-30-2021

STATE OF WEST VIRGINIA,

COUNTY OF Harrison, TO-WIT:

Taken, subscribed and sworn to before me this 30 day of August, 2021.

By Commission expires November 17, 2025

(Seal)

[Handwritten Signature]
 (Notary Public)

