



Purchasing Division  
 2019 Washington Street East  
 Post Office Box 50130  
 Charleston, WV 25305-0130

State of West Virginia  
 Request for Quotation  
 13 - Equipment

Proc Folder: 616608

Doc Description: ADDENDUM 1 STEEL DOUBLE DRUM VIBRATORY ROLLER (7020EC03)

Proc Type: Central Master Agreement

Date Issued	Solicitation Closes	Solicitation No	Version
2019-09-27	2019-10-08 13:30:00	CRFQ 0803 DOT2000000026	2

**BID RECEIVING LOCATION**

BID CLERK  
 DEPARTMENT OF ADMINISTRATION  
 PURCHASING DIVISION  
 2019 WASHINGTON ST E  
 CHARLESTON  
 US

WV 25305

**VENDOR**

Vendor Name, Address and Telephone Number:

West Virginia Tractor Company  
 P.O. Box 473  
 Charleston, WV 25322  
  
 304-346-5301

RECEIVED  
 2019 OCT -8 AM 9:46  
 WV PURCHASING  
 DIVISION

**FOR INFORMATION CONTACT THE BUYER**

Crystal G Hustead  
 (304) 558-2402  
 crystal.g.hustead@wv.gov

Signature X

*Crystal G Hustead*

FEIN #

550621655

DATE

10-7-2019

All offers subject to all terms and conditions contained in this solicitation

**ADDITIONAL INFORMATION:**

THE STATE OF WEST VIRGINIA PURCHASING DIVISION FOR THE AGENCY, WEST VIRGINIA DIVISION OF HIGHWAYS, IS SOLICITING BIDS TO ESTABLISH AN OPEN-END CONTRACT FOR STEEL DOUBLE DRUM VIBRATORY ROLLER PER THE ATTACHED DOCUMENTS.

QUESTIONS REGARDING THE SOLICITATION MUST BE SUBMITTED IN WRITING TO CRYSTAL.G.HUSTEAD@WV.GOV PRIOR TO THE QUESTION PERIOD DEADLINE CONTAINED IN THE INSTRUCTIONS TO VENDORS SUBMITTING BIDS.

INVOICE TO	SHIP TO
DIVISION OF HIGHWAYS EQUIPMENT DIVISION RT 33 83 BRUSHY ROAD CROSSING, PO BOX 610 BUCKHANNON WV26201 US	DIVISION OF HIGHWAYS EQUIPMENT DIVISION 83 BRUSHY FORK RD CROSSING BUCKHANNON WV 26201 US

Line	Comm Ln Desc	Qty	Unit Issue	Unit Price	Total Price
1	CLASS 592 STEEL DOUBLE DRUM VIBRATORY ROLLER	15.00000	EA		

Comm Code	Manufacturer	Specification	Model #
22101505			

**Extended Description :**

CLASS 592 STEEL DOUBLE DRUM VIBRATORY ROLLER

**SCHEDULE OF EVENTS**

Line	Event	Event Date
1	MANDATORY PRE-BID MEETING	2019-09-12
2	VENDOR QUESTION DEADLINE	2019-09-23

Exhibit A Pricing Page

CRFQ DOT2000000026

STEEL DOUBLE DRUM VIBRATORY ROLLER (7020EC03)

Item No.	Description:	Make/Model & Year	Estimated Unit Quantity	Unit Price	Total Cost
1	Steel Double Drum Vibratory Roller	BOMAG BW 151 AD-5 2020 and later as ordered	15	\$93,990	\$1,409,850
<b>Total Bid Amount</b> 					\$1,409,850

Vendor Information

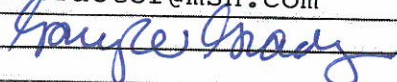
Company Name:	West Virginia Tractor Company
Contract Manager:	Gary W. Grady
Address:	P.O. Box 473 Charleston, WV 25322
Phone:	304-346-5301
Fax:	304-346-5305
Email:	wvtractor@msn.com
Signature:	

**REQUEST FOR QUOTATION**  
**CRFQ DOT2000000026**  
**(WVDOH CLASS 592) Steel Double Drum Vibratory Roller (7020EC03)**

---

**8.2 Reports:** Vendor shall provide quarterly reports and annual summaries to the Agency showing the Agency's items purchased, quantities of items purchased, and total dollar value of the items purchased. Vendor shall also provide reports, upon request, showing the items purchased during the term of this Contract, the quantity purchased for each of those items, and the total value of purchases for each of those items. Failure to supply such reports may be grounds for cancellation of this Contract.

**8.3 Contract Manager:** During its performance of this Contract, Vendor must designate and maintain a primary contract manager responsible for overseeing Vendor's responsibilities under this Contract. The Contract manager must be available during normal business hours to address any customer service or other issues related to this Contract. Vendor should list its Contract manager and his or her contact information below.

**Contract Manager:** Gary W. Grady  
**Telephone Number:** 304-346-5301  
**Fax Number:** 304-346-5301  
**Email Address:** wvtractor@msn.com

**DESIGNATED CONTACT:** Vendor appoints the individual identified in this Section as the Contract Administrator and the initial point of contact for matters relating to this Contract.

Gary W. Grady, President

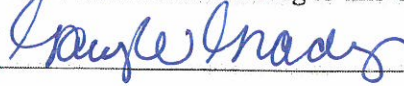

(Name, Title)

Gary W. Grady, President

(Printed Name and Title)

P.O. Box 473 Charleston, WV 25322

(Address)

304-346-5301                      304-346-5305

(Phone Number) / (Fax Number)

wvtractor@msn.com

(email address)

**CERTIFICATION AND SIGNATURE:** By signing below, or submitting documentation through wvOASIS, I certify that I have reviewed this Solicitation in its entirety; that I understand the requirements, terms and conditions, and other information contained herein; that this bid, offer or proposal constitutes an offer to the State that cannot be unilaterally withdrawn; that the product or service proposed meets the mandatory requirements contained in the Solicitation for that product or service, unless otherwise stated herein; that the Vendor accepts the terms and conditions contained in the Solicitation, unless otherwise stated herein; that I am submitting this bid, offer or proposal for review and consideration; that I am authorized by the vendor to execute and submit this bid, offer, or proposal, or any documents related thereto on vendor's behalf; that I am authorized to bind the vendor in a contractual relationship; and that to the best of my knowledge, the vendor has properly registered with any State agency that may require registration.

West Virginia Tractor Company

(Company)

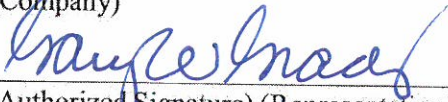

President

(Authorized Signature) (Representative Name, Title)

Gary W. Grady President

(Printed Name and Title of Authorized Representative)

10-7-2019

(Date)

304-346-5301                      304-346-5305

(Phone Number) (Fax Number)

ADDENDUM ACKNOWLEDGEMENT FORM  
SOLICITATION NO.: CRFQ DOT2000000026

Instructions: Please acknowledge receipt of all addenda issued with this solicitation by completing this addendum acknowledgment form. Check the box next to each addendum received and sign below. Failure to acknowledge addenda may result in bid disqualification.

Acknowledgment: I hereby acknowledge receipt of the following addenda and have made the necessary revisions to my proposal, plans and/or specification, etc.

Addendum Numbers Received:  
(Check the box next to each addendum received)

- |  |  |
|--|--|
| <input checked="" type="checkbox"/> Addendum No. 1 | <input type="checkbox"/> Addendum No. 6  |
| <input type="checkbox"/> Addendum No. 2            | <input type="checkbox"/> Addendum No. 7  |
| <input type="checkbox"/> Addendum No. 3            | <input type="checkbox"/> Addendum No. 8  |
| <input type="checkbox"/> Addendum No. 4            | <input type="checkbox"/> Addendum No. 9  |
| <input type="checkbox"/> Addendum No. 5            | <input type="checkbox"/> Addendum No. 10 |

I understand that failure to confirm the receipt of addenda may be cause for rejection of this bid. I further understand that any verbal representation made or assumed to be made during any oral discussion held between Vendor's representatives and any state personnel is not binding. Only the information issued in writing and added to the specifications by an official addendum is binding.

West Virginia Tractor Company

Company

  
Authorized Signature

10-7-2019

Date

NOTE: This addendum acknowledgment should be submitted with the bid to expedite document processing.

## West Virginia Ethics Commission



### Disclosure of Interested Parties to Contracts

Pursuant to *W. Va. Code* § 6D-1-2, a state agency may not enter into a contract, or a series of related contracts, that has/have an actual or estimated value of \$1 million or more until the business entity submits to the contracting state agency a Disclosure of Interested Parties to the applicable contract. In addition, the business entity awarded a contract is obligated to submit a supplemental Disclosure of Interested Parties reflecting any new or differing interested parties to the contract within 30 days following the completion or termination of the applicable contract.

For purposes of complying with these requirements, the following definitions apply:

*"Business entity"* means any entity recognized by law through which business is conducted, including a sole proprietorship, partnership or corporation, but does not include publicly traded companies listed on a national or international stock exchange.

*"Interested party"* or *"Interested parties"* means:

- (1) A business entity performing work or service pursuant to, or in furtherance of, the applicable contract, including specifically sub-contractors;
- (2) the person(s) who have an ownership interest equal to or greater than 25% in the business entity performing work or service pursuant to, or in furtherance of, the applicable contract. (This subdivision does not apply to a publicly traded company); and
- (3) the person or business entity, if any, that served as a compensated broker or intermediary to actively facilitate the applicable contract or negotiated the terms of the applicable contract with the state agency. (This subdivision does not apply to persons or business entities performing legal services related to the negotiation or drafting of the applicable contract.)

*"State agency"* means a board, commission, office, department or other agency in the executive, judicial or legislative branch of state government, including publicly funded institutions of higher education: Provided, that for purposes of *W. Va. Code* § 6D-1-2, the West Virginia Investment Management Board shall not be deemed a state agency nor subject to the requirements of that provision.

The contracting business entity must complete this form and submit it to the contracting state agency prior to contract award and to complete another form within 30 days of contract completion or termination.

*This form was created by the State of West Virginia Ethics Commission, 210 Brooks Street, Suite 300, Charleston, WV 25301-1804. Telephone: (304)558-0664; fax: (304)558-2169; e-mail: [ethics@wv.gov](mailto:ethics@wv.gov); website: [www.ethics.wv.gov](http://www.ethics.wv.gov).*

West Virginia Ethics Commission  
**Disclosure of Interested Parties to Contracts**

(Required by W. Va. Code § 6D-1-2)

West Virginia Tractor Company

Name of Contracting Business Entity: \_\_\_\_\_ Address: P.O. Box 473  
Charleston, WV 25322

Name of Authorized Agent: Gary W. Grady Address: Charleston, WV 25322

Contract Number: DOT20\*26 Contract Description: Steel Double Drum Vibratory Roller

Governmental agency awarding contract: DOT-WVDOH

Check here if this is a Supplemental Disclosure

List the Names of Interested Parties to the contract which are known or reasonably anticipated by the contracting business entity for each category below (attach additional pages if necessary):

1. Subcontractors or other entities performing work or service under the Contract

Check here if none, otherwise list entity/individual names below.

2. Any person or entity who owns 25% or more of contracting entity (not applicable to publicly traded entities)

Check here if none, otherwise list entity/individual names below.

Gary W. and Christine B. Grady

Steve Basham

Susan T. Martin

3. Any person or entity that facilitated, or negotiated the terms of, the applicable contract (excluding legal services related to the negotiation or drafting of the applicable contract)

Check here if none, otherwise list entity/individual names below.

Signature: Gary W. Grady

Date Signed: 10-7-2019

**Notary Verification**

West Virginia

Kanawha

State of \_\_\_\_\_, County of \_\_\_\_\_

I, Gary W. Grady

the authorized agent of the contracting business entity listed above, being duly sworn, acknowledge that the Disclosure herein is being made under oath and under the penalty of perjury.

Taken, sworn to and subscribed before me this 7th day of October, 2019

Steven B. Basham

Notary Public's Signature

**To be completed by State Agency:**

Date Received by State Agency: \_\_\_\_\_

Date submitted to Ethics Commission: \_\_\_\_\_

Governmental agency submitting Disclosure: \_\_\_\_\_

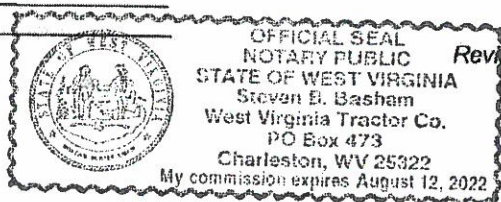



STATE OF WEST VIRGINIA  
Purchasing Division

**PURCHASING AFFIDAVIT**

**CONSTRUCTION CONTRACTS:** Under W. Va. Code § 5-22-1(i), the contracting public entity shall not award a construction contract to any bidder that is known to be in default on any monetary obligation owed to the state or a political subdivision of the state, including, but not limited to, obligations related to payroll taxes, property taxes, sales and use taxes, fire service fees, or other fines or fees.

**ALL CONTRACTS:** Under W. Va. Code §5A-3-10a, no contract or renewal of any contract may be awarded by the state or any of its political subdivisions to any vendor or prospective vendor when the vendor or prospective vendor or a related party to the vendor or prospective vendor is a debtor and: (1) the debt owed is an amount greater than one thousand dollars in the aggregate; or (2) the debtor is in employer default.

**EXCEPTION:** The prohibition listed above does not apply where a vendor has contested any tax administered pursuant to chapter eleven of the W. Va. Code, workers' compensation premium, permit fee or environmental fee or assessment and the matter has not become final or where the vendor has entered into a payment plan or agreement and the vendor is not in default of any of the provisions of such plan or agreement.

**DEFINITIONS:**

**"Debt"** means any assessment, premium, penalty, fine, tax or other amount of money owed to the state or any of its political subdivisions because of a judgment, fine, permit violation, license assessment, defaulted workers' compensation premium, penalty or other assessment presently delinquent or due and required to be paid to the state or any of its political subdivisions, including any interest or additional penalties accrued thereon.

**"Employer default"** means having an outstanding balance or liability to the old fund or to the uninsured employers' fund or being in policy default, as defined in W. Va. Code § 23-2c-2, failure to maintain mandatory workers' compensation coverage, or failure to fully meet its obligations as a workers' compensation self-insured employer. An employer is not in employer default if it has entered into a repayment agreement with the Insurance Commissioner and remains in compliance with the obligations under the repayment agreement.

**"Related party"** means a party, whether an individual, corporation, partnership, association, limited liability company or any other form or business association or other entity whatsoever, related to any vendor by blood, marriage, ownership or contract through which the party has a relationship of ownership or other interest with the vendor so that the party will actually or by effect receive or control a portion of the benefit, profit or other consideration from performance of a vendor contract with the party receiving an amount that meets or exceeds five percent of the total contract amount.

**AFFIRMATION:** By signing this form, the vendor's authorized signer affirms and acknowledges under penalty of law for false swearing (W. Va. Code §61-5-3) that: (1) for construction contracts, the vendor is not in default on any monetary obligation owed to the state or a political subdivision of the state, and (2) for all other contracts, that neither vendor nor any related party owe a debt as defined above and that neither vendor nor any related party are in employer default as defined above, unless the debt or employer default is permitted under the exception above.

**WITNESS THE FOLLOWING SIGNATURE:**

Vendor's Name: West Virginia Tractor Company

Authorized Signature: *Gaule Gray* Date: 10-7-19

State of West Virginia

County of Kanawha, to-wit:

Taken, subscribed, and sworn to before me this 7 day of October, 2019.

My Commission expires August 12, 2022.

**AFFIX SEAL HERE**

**NOTARY PUBLIC** *Steven B. Basham*

*Purchasing Affidavit (Revised 01/19/2018)*

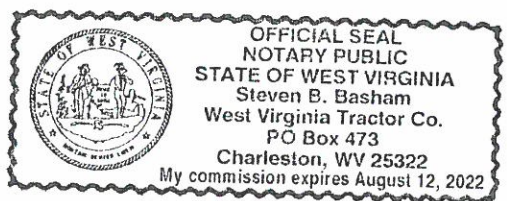

# State of West Virginia

## VENDOR PREFERENCE CERTIFICATE

Certification and application is hereby made for Preference in accordance with **West Virginia Code**, §5A-3-37. (Does not apply to construction contracts). **West Virginia Code**, §5A-3-37, provides an opportunity for qualifying vendors to request (at the time of bid) preference for their residency status. Such preference is an evaluation method only and will be applied only to the cost bid in accordance with the **West Virginia Code**. This certificate for application is to be used to request such preference. The Purchasing Division will make the determination of the Vendor Preference, if applicable.

**1. Application is made for 2.5% vendor preference for the reason checked:**

- Bidder is an individual resident vendor and has resided continuously in West Virginia, or bidder is a partnership, association or corporation resident vendor and has maintained its headquarters or principal place of business continuously in West Virginia, for four (4) years immediately preceding the date of this certification; **or**,
- Bidder is a resident vendor partnership, association, or corporation with at least eighty percent of ownership interest of bidder held by another entity that meets the applicable four year residency requirement; **or**,
- Bidder is a nonresident vendor which has an affiliate or subsidiary which employs a minimum of one hundred state residents and which has maintained its headquarters or principal place of business within West Virginia continuously for the four (4) years immediately preceding the date of this certification; **or**,

**2. Application is made for 2.5% vendor preference for the reason checked:**

- Bidder is a resident vendor who certifies that, during the life of the contract, on average at least 75% of the employees working on the project being bid are residents of West Virginia who have resided in the state continuously for the two years immediately preceding submission of this bid; **or**,

**3. Application is made for 2.5% vendor preference for the reason checked:**

- Bidder is a nonresident vendor that employs a minimum of one hundred state residents, or a nonresident vendor which has an affiliate or subsidiary which maintains its headquarters or principal place of business within West Virginia and employs a minimum of one hundred state residents, and for purposes of producing or distributing the commodities or completing the project which is the subject of the bidder's bid and continuously over the entire term of the project, on average at least seventy-five percent of the bidder's employees or the bidder's affiliate's or subsidiary's employees are residents of West Virginia who have resided in the state continuously for the two immediately preceding years and the vendor's bid; **or**,

**4. Application is made for 5% vendor preference for the reason checked:**

- Bidder meets either the requirement of both subdivisions (1) and (2) or subdivision (1) and (3) as stated above; **or**,

**5. Application is made for 3.5% vendor preference who is a veteran for the reason checked:**

- Bidder is an individual resident vendor who is a veteran of the United States armed forces, the reserves or the National Guard and has resided in West Virginia continuously for the four years immediately preceding the date on which the bid is submitted; **or**,

**6. Application is made for 3.5% vendor preference who is a veteran for the reason checked:**

- Bidder is a resident vendor who is a veteran of the United States armed forces, the reserves or the National Guard, if, for purposes of producing or distributing the commodities or completing the project which is the subject of the vendor's bid and continuously over the entire term of the project, on average at least seventy-five percent of the vendor's employees are residents of West Virginia who have resided in the state continuously for the two immediately preceding years.

**7. Application is made for preference as a non-resident small, women- and minority-owned business, in accordance with West Virginia Code §5A-3-59 and West Virginia Code of State Rules.**

- Bidder has been or expects to be approved prior to contract award by the Purchasing Division as a certified small, women- and minority-owned business.

**8. Application is made for reciprocal preference.**

- Bidder is a West Virginia resident and is requesting reciprocal preference to the extent that it applies.

Bidder understands if the Secretary of Revenue determines that a Bidder receiving preference has failed to continue to meet the requirements for such preference, the Secretary may order the Director of Purchasing to: (a) rescind the contract or purchase order; or (b) assess a penalty against such Bidder in an amount not to exceed 5% of the bid amount and that such penalty will be paid to the contracting agency or deducted from any unpaid balance on the contract or purchase order.

By submission of this certificate, Bidder agrees to disclose any reasonably requested information to the Purchasing Division and authorizes the Department of Revenue to disclose to the Director of Purchasing appropriate information verifying that Bidder has paid the required business taxes, provided that such information does not contain the amounts of taxes paid nor any other information deemed by the Tax Commissioner to be confidential.

**Bidder hereby certifies that this certificate is true and accurate in all respects; and that if a contract is issued to Bidder and if anything contained within this certificate changes during the term of the contract, Bidder will notify the Purchasing Division in writing immediately.**

Bidder: West Virginia Tractor Company

Signed: 

Date: 10-7-2019

Title: President



# CERTIFICATE OF GARAGE INSURANCE

DATE (MM/DD/YYYY)  
03/18/2019

**THIS CERTIFICATE IS ISSUED AS A MATTER OF INFORMATION ONLY AND CONFERS NO RIGHTS UPON THE CERTIFICATE HOLDER. THIS CERTIFICATE DOES NOT AFFIRMATIVELY OR NEGATIVELY AMEND, EXTEND OR ALTER THE COVERAGE AFFORDED BY THE POLICIES BELOW. THIS CERTIFICATE OF INSURANCE DOES NOT CONSTITUTE A CONTRACT BETWEEN THE ISSUING INSURER(S), AUTHORIZED REPRESENTATIVE OR PRODUCER, AND THE CERTIFICATE HOLDER.**

**IMPORTANT: If the certificate holder is an ADDITIONAL INSURED, the policy(ies) must have ADDITIONAL INSURED provisions or be endorsed. If SUBROGATION IS WAIVED, subject to the terms and conditions of the policy, certain policies may require an endorsement. A statement on this certificate does not confer rights to the certificate holder in lieu of such endorsement(s).**

<b>PRODUCER</b> Jeremy Stanford	<b>CONTACT NAME:</b> Sentry Customer Service
	<b>PHONE (A/C, No, Ext):</b> 800-473-6879 <b>FAX (A/C, No):</b> 800-514-7191
	<b>EMAIL ADDRESS:</b> businessproducts_direct@sentry.com
<b>INSURER(S) AFFORDING COVERAGE</b>	
<b>INSURER A :</b> Sentry Select Insurance Company	<b>NAIC #</b> 21180
<b>INSURED</b> West Virginia Tractor Co. PO Box 473 214 Virginia Street West Charleston, WV 25322	<b>INSURER B :</b>
	<b>INSURER C :</b>
	<b>INSURER D :</b>
	<b>INSURER E :</b>
	<b>INSURER F :</b>

**COVERAGES      PROD / CUSTOMER ID:      CERTIFICATE #: 1311744      REVISION #:**

THIS IS TO CERTIFY THAT THE POLICIES OF INSURANCE LISTED BELOW HAVE BEEN ISSUED TO THE INSURED NAMED ABOVE FOR THE POLICY PERIOD INDICATED. NOTWITHSTANDING ANY REQUIREMENT, TERM OR CONDITION OF ANY CONTRACT OR OTHER DOCUMENT WITH RESPECT TO WHICH THIS CERTIFICATE MAY BE ISSUED OR MAY PERTAIN, THE INSURANCE AFFORDED BY THE POLICIES DESCRIBED HEREIN IS SUBJECT TO ALL THE TERMS, EXCLUSIONS AND CONDITIONS OF SUCH POLICIES. LIMITS SHOWN MAY HAVE BEEN REDUCED BY PAID CLAIMS.

INSR LTR	TYPE OF INSURANCE	ADDL INSRD	SUBR WVD	POLICY NUMBER	POLICY EFF (MM/DD/YYYY)	POLICY EXP (MM/DD/YYYY)	LIMITS	
A	<input checked="" type="checkbox"/> GARAGE LIABILITY <input type="checkbox"/> ANY AUTO OWNED AUTOS ONLY <input type="checkbox"/> HIRED AUTOS ONLY <input type="checkbox"/> NON-OWNED AUTOS USED IN GARAGE BUSINESS			A0053698001	04/01/2019	04/01/2020	AUTO ONLY (Ea accident)	\$ 500,000
							OTHER THAN AUTO ONLY	EA ACCIDENT \$ 500,000 AGGREGATE \$ 2,500,000
A	<input type="checkbox"/> GARAGE KEEPERS LIABILITY <input type="checkbox"/> LEGAL LIABILITY <input checked="" type="checkbox"/> DIRECT BASIS <input type="checkbox"/> PRIMARY <input type="checkbox"/> EXCESS			A0053698001	04/01/2019	04/01/2020	<input checked="" type="checkbox"/> COMP / OTC SPECIFIED PERILS    LOC	1    \$ 250,000
							<input checked="" type="checkbox"/> COLLISION    LOC	1    \$ 250,000
							LOC	\$
A	<input checked="" type="checkbox"/> COMMERCIAL GENERAL LIABILITY <input type="checkbox"/> CLAIMS-MADE <input checked="" type="checkbox"/> OCCUR			A0053698005	04/01/2019	04/01/2020	EACH OCCURRENCE	\$ 500,000
							DAMAGE TO RENTED PREMISES (Ea occurrence)	\$ 100,000
							MED EXP (Any one person)	\$ 5,000
							PERSONAL & ADV INJURY	\$ 500,000
							GENERAL AGGREGATE	\$ 1,500,000
A	<input checked="" type="checkbox"/> UMBRELLA LIAB <input checked="" type="checkbox"/> OCCUR <input checked="" type="checkbox"/> EXCESS LIAB <input type="checkbox"/> CLAIMS-MADE			A0053698008	04/01/2019	04/01/2020	EACH OCCURRENCE	\$ 2,000,000
							AGGREGATE	\$ 6,000,000
							PRODUCTS - COMP/OP AGG	\$ 6,000,000
	<input type="checkbox"/> DED <input type="checkbox"/> RETENTION \$							
	<b>WORKERS COMPENSATION AND EMPLOYERS' LIABILITY</b> ANY PROPRIETOR/PARTNER/EXECUTIVE OFFICER/MEMBER EXCLUDED? <input type="checkbox"/> Y / N (Mandatory in NH) If yes, describe under REMARKS below	N / A					<input type="checkbox"/> PER STATUTE <input type="checkbox"/> OTH-ER	
							E.L. EACH ACCIDENT	\$
							E.L. DISEASE - EA EMPLOYEE	\$
							E.L. DISEASE - POLICY LIMIT	\$

REMARKS (ACORD 101, Additional Remarks Schedule, may be attached if more space is required)  
Refer to attached

### CERTIFICATE HOLDER

WV DOH  
83 Brushy Road Xing  
PO Box 610  
Buckhannon, WV 26201-0610

### CANCELLATION

SHOULD ANY OF THE ABOVE DESCRIBED POLICIES BE CANCELLED BEFORE THE EXPIRATION DATE THEREOF, NOTICE WILL BE DELIVERED IN ACCORDANCE WITH THE POLICY PROVISIONS.

AUTHORIZED REPRESENTATIVE

ACORD 30 (2016/03)

Page 1 of 2

© 2010-2015 ACORD CORPORATION. All rights reserved.

A0053698  
Sentry Select Insurance Company

The ACORD name and logo are registered marks of ACORD

03/18/2019

1 00001 000000000 19077 0 N

c8c42b67-6709-4e1b-9224-0c7e37138b41

0027020044349226781026201061010



AGENCY CUSTOMER ID: XXXXXX1655

LOC #: \_\_\_\_\_

### ADDITIONAL REMARKS SCHEDULE

Page 2 of 2

<b>AGENCY</b> Jeremy Stanford		<b>NAMED INSURED</b> West Virginia Tractor Co.	
<b>POLICY NUMBER</b> A0053698001			
<b>CARRIER</b> Sentry Select Insurance Company	<b>NAIC CODE</b> 21180	<b>EFFECTIVE DATE:</b> 04/01/2019	

#### ADDITIONAL REMARKS

THIS ADDITIONAL REMARKS FORM IS A SCHEDULE TO ACORD FORM,

FORM NUMBER: ACORD 30    FORM TITLE: Certificate Of Garage Insurance

#### General Liability

WV DOH AND STATE OF WEST VIRGINIA ARE ADDITIONAL INSURED ON THE GENERAL LIABILITY, PER THE POLICY PROVISIONS IF REQUIRED AS SUCH IN WRITTEN CONTRACT WITH THE NAMED INSURED. GARAGE LIABILITY INCLUDES THE AUTOMOBILE LIABILITY. ANY AUTO COVERAGE INCLUDED. EXCESS/UMBRELLA LIABILITY FOLLOWS FORM.



# SUPERIOR TECHNOLOGY. OPTIMAL COMPACTION.

ARTICULATED TANDEM ROLLERS, 15,000 LB AND OVER.



# FIVE GOOD REASONS TO CHOOSE BOMAG.

# 1

## MAINTENANCE: FAST!

Daily maintenance is essential and with EasyService all maintenance points can be easily reached from the ground. And without any grease nipples.

# 5

## ECONOMY: OUTSTANDING!

ECOMODE provides load-dependent and economical working without high engine speeds. Giving excellent fuel economy and maximum efficiency on every type of road construction project.



# 4

## VIBRATION: THREE CHOICES!

Only BOMAG tandem rollers offer you three vibration systems. With double vibration, TanGO and ASPHALT MANAGER you have three technologies to choose from.

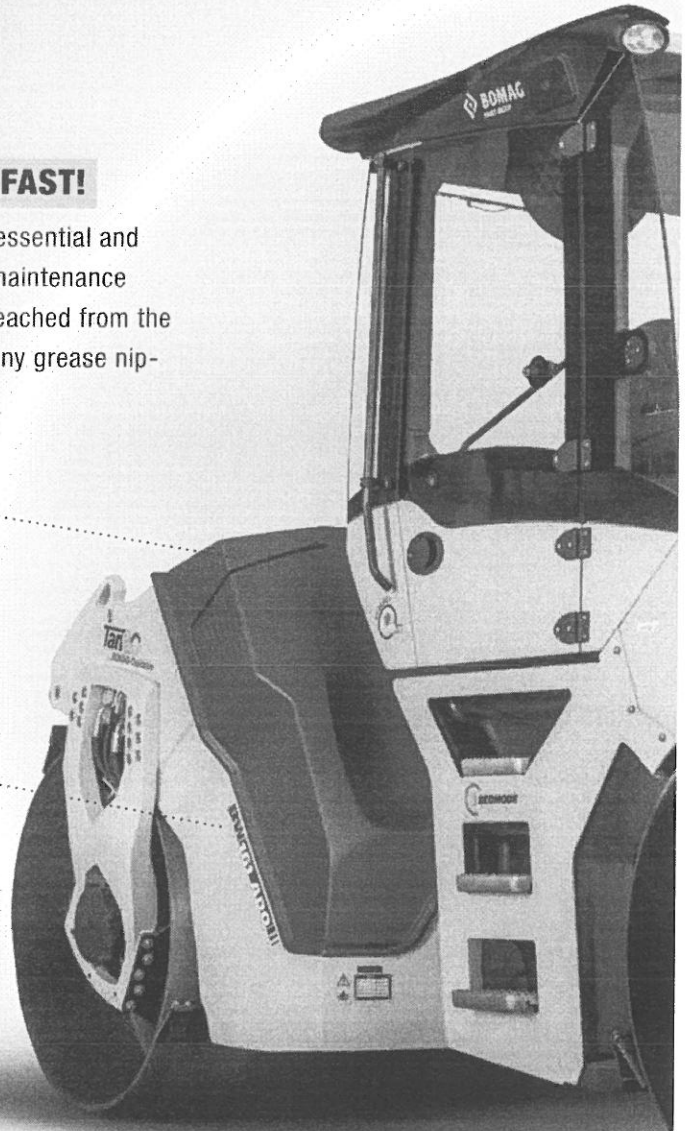



# 2

## **OPERATORS STATION: OPTIMISED!**

BOMAG always considers the roller operator. The operator's work place provides the best view and offers space and operating comfort at the highest level. This ensures good workmanship and efficiency.

# 3

## **COMPACTION: RIGHT FROM THE GET-GO!**

Simple and reliable compaction thanks to ECONOMIZER and BCM. Unnecessary passes are avoided, compaction is accurately documented. Optimised compaction is so easy.



## YOUR CHOICE.

*Each application is different – all construction sites come with new challenges. This is why the right philosophy is not what matters in asphalt compaction, but the right technology! With BOMAG you can choose how to match your operation and your work. We always have the right technology at hand for every application. And all from one source.*



### OUR STANDARD: DOUBLE VIBRATION

With two amplitudes and individually operable drums, this technology covers a wide range of applications on many projects. Proverbial BOMAG quality goes without saying and our equipment specs meet every requirement.

### FOR SENSITIVE WORK: TanGO

Wherever careful compaction is required, TanGO oscillation from BOMAG is the answer. The high wear-resistant drums and a factory warranty of 6,000 operating hours always put you on the safe side.

### NO MORE GUESSWORK: ASPHALT MANAGER.

Exclusively from BOMAG. This is a Manager that you really can trust. Dial-in the layer thickness and off you go. Everything is controlled and monitored by the ASPHALT MANAGER: material, degree of compaction, temperature, control of the direction of compaction. The operator just concentrates on the rolling pattern and converses with colleagues on interconnected rolling operations.



Which manufacturer offers a choice of three vibration systems? BOMAG. Because BOMAG knows exactly what every contractor wants.





# TECHNICAL DATA

TANDEM ROLLERS

BW 141 AD-5, BW 151 AD-5, BW 154 AD-5



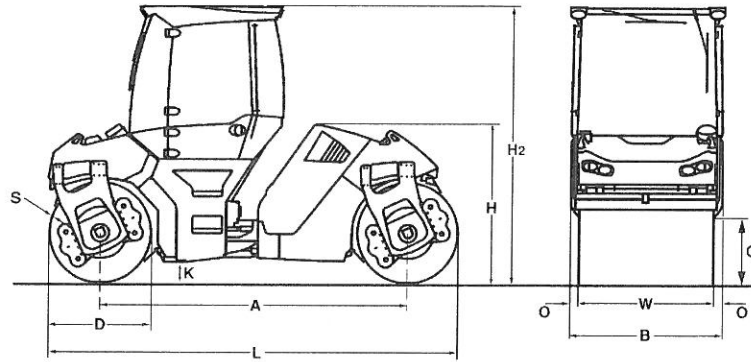

**Dimensions in in**

	A	B	C	D	H	H2	K	L	O	S	W
BW 141 AD-5	129.9	65.5	28.7	43.3	88.2	118.1	9.8	173.2	3.2	0.6	59.1
BW 151 AD-5	129.9	74.2	28.7	43.3	86.6	118.1	9.8	173.2	3.2	0.6	66.1
BW 154 AD-5	129.9	74.2	28.7	43.3	88.2	118.1	9.8	173.2	3.2	0.6	66.1

**Shipping dimensions in cub.yd**

BW 141 AD-5  
 BW 151 AD-5  
 BW 154 AD-5

**without ROPS**

21.443  
 23.336  
 23.767

**with ROPS**

28.712  
 31.824  
 31.824

Machine type	Compaction output (cub.yd/h) at recommended soil layer thicknesses		
	Gravel, sand	Mixed soil	Silt, clay
BW 141 AD-5	183.1-366.2	157.0-327.0	85.0-170.0
BW 151 AD-5	209.3-418.5	196.2-392.4	98.1-196.2

Machine type	Compaction output (t/h) at different asphalt layer thicknesses		
	0.8-1.6 in	2.4-3.1 in	3.9-5.5 in
BW 141 AD-5	35-70	70-150	100-180
BW 151 AD-5	40-80	80-170	120-200
BW 154 AD-5	40-80	80-170	120-200

Technical Data		BOMAG BW 141 AD-5	BOMAG BW 151 AD-5	BOMAG BW 154 AD-5
<b>Weights</b>				
Operating weight CECE w. cab. ....	lb	15,212	16,755	18,298
Axle load, front CECE .....	lb	7,848	8,598	9,370
Axle load, rear CECE .....	lb	7,363	8,157	8,929
Static linear load, front CECE .....	lb/in	132.7	130.0	141.7
Static linear load, rear CECE .....	lb/in	124.9	123.2	135.0
Grossweight .....	lb	19,180	20,503	21,826
<b>Dimensions</b>				
Track radius, inner .....	in	176.4	172.8	172.8
<b>Drums</b>				
Split drum .....		no	no	front + rear
<b>Driving Characteristics</b>				
Max. travel speed .....	mph	0- 7.5	0- 7.5	0- 7.5
Max. gradeability without/with vibr. ...	%	40/30	40/30	36/30
<b>Drive</b>				
Engine manufacturer .....		Kubota	Kubota	Kubota
Type .....		V3307 CR-T	V3307 CR-T	V3307 CR-T
Emission stage .....		3b/4	3b/4	3b/4
Cooling .....		water	water	water
Number of cylinders .....		4	4	4
Performance ISO 14396 .....	kW	55.4	55.4	55.4
Speed .....	min-1	2,400	2,400	2,400
Electric equipment .....	V	12	12	12
<b>Brakes</b>				
Service brake .....		hydrost.	hydrost.	hydrost.
Parking brake .....		multi disc	multi disc	multi disc
<b>Steering</b>				
Steering system .....		oscil.artic.	oscil.artic.	oscil.artic.
<b>Exciter system</b>				
Vibrating drum .....		front + rear	front + rear	front + rear
Autom. vibr. shut off .....		standard	standard	standard
Frequency .....	vpm	2,700/3,300	2,700/3,300	2,700/3,300
Amplitude .....	in	0.028/0.011	0.027/0.010	0.024/0.012
Centrifugal force .....	lb	16,861/10,116	16,861/10,116	20,008/14,613
Centrifugal force .....	t	7.6/4.6	7.6/4.6	9.1/6.6
<b>Capacities</b>				
Fuel .....	gal	33.0	33.0	33.0
Water .....	gal	158.5	158.5	158.5

Technical modifications reserved. Machines may be shown with options.

### Standard Equipment

- 2 amplitudes / 2 frequencies
- ECOMODE
- Autom. vibration operation
- Individual vibration control
- Driver's seat, slewable
  - laterally slidable with steering wheel
- Emergency stop button
- On-board computer
  - engine speed
  - Speedometer
  - Fuel consumption
  - Engine temperature
- V-belt protection
- Pressure sprinkling system with 2 pumps
- Indicator and hazard lights
- Back-up alarm
- Battery disconnect switch
- Compartments for documents and tools

### Optional Equipment

- ROPS cabin with seat belts
  - + heating, Ventilation
  - + 4 Working head lights
- ROPS cabin with air conditioning
- Rotary beacon
- Crab-walk to both sides (6.7in)
- 2 LED-lights for cabin roof (flatbeam)
- Edge cutter
- Special painting
- Environmentally compliant hydraulic oil
- Radio/Radio preparation
- ROPS/FOPS with safety belt
- Precision spreader BS150 laterally slidable
- Asphalt temperature display
- Additional weight 600kg (BW151AD-5)
- Lighting for drum edge front and rear
- Seat heating
- Frequency 4,200vpm
- Approval by the German TÜV
- BOMAG TELEMATIC POWER
- Outside mirrors
- ECONOMIZER
- BCM-Documentation system



PRUS 921 00 010

190916 Sa

**BOMAG Americas, Inc.**  
125 Blue Granite Parkway  
Ridgeway, SC 29130  
USA  
Tel. +1 803 3370700  
Fax +1 803 3370800  
[www.bomag.com/us](http://www.bomag.com/us)



**BOMAG** FAYAT GROUP  
BOMAG Americas, Inc.  
125 Blue Granite Parkway • Ridgeway, SC 29130  
Tel: 803 337-0700 • Fax: 803 337-0800



# PRODUCT WARRANTY

[www.bomag.com/us](http://www.bomag.com/us)

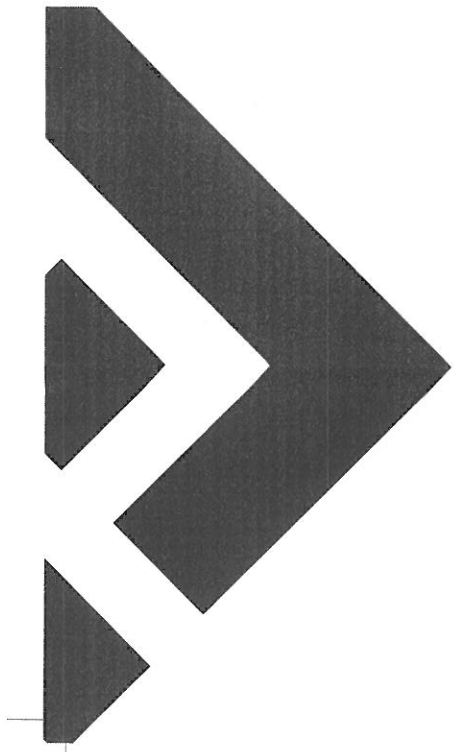

## CERTIFICATE OF GENERAL EQUIPMENT WARRANTY

**BOMAG Americas, Inc.** warrants new compaction equipment products sold by it to be free of defects in materials or workmanship at the time of manufacture. This Warranty is subject to the following conditions:

- A. The warranty period for all ride-on compaction, stabilization, milling, and paving products is twelve (12) consecutive months or 1000 hours, whichever comes first, covering parts and labor from the Date of Delivery for initial use.
- B. The warranty period for all walk-behind compaction products is twelve (12) consecutive months covering parts and labor from the Date of Delivery for initial use.
- C. The warranty period for the refuse compactor is twelve (12) consecutive months or 2000 hours, whichever comes first, covering parts and labor from the Date of Delivery for initial use.

**BOMAG Americas, Inc.** obligation and liability under this warranty is expressly limited to the cost, exclusive of freight, duty, taxes, handling charges, of, during normal working hours, replacing or, at the sole option of **BOMAG Americas, Inc.**, repairing by an authorized BOMAG Americas equipment distributor, parts determined, upon inspection to have been defective in material or workmanship within the applicable period, to be not as warranted.

- D. The warranty for replacement or repair parts installed in the product shall be six (6) months from the Date of Installation. This warranty is limited to providing a replacement part; not including freight, duty, taxes, handling charges or cost of installation; to replace that part found not to be as warranted or, in the alternative, at the sole option of **BOMAG Americas, Inc.**, the cost, excluding travel and freight, of repairs, during normal working hours, to that part found to be not as warranted.

**THIS WARRANTY IS EXCLUSIVE AND IN LIEU OF ALL OTHER REPRESENTATIONS AND WARRANTIES, EXPRESSED OR IMPLIED, INCLUDING BUT NOT LIMITED TO ANY IMPLIED WARRANTY OF MERCHANTABILITY OR FITNESS FOR A PARTICULAR PURPOSE. BOMAG AMERICAS' OBLIGATION SHALL NOT INCLUDE ANY LIABILITY FOR DIRECT, INDIRECT, INCIDENTAL OR CONSEQUENTIAL DAMAGE OR DELAY.**

This warranty covers only defects in materials and workmanship or noncompliance in products sold by **BOMAG Americas, Inc.**

Warranty coverage is not extended to repairs or parts and services required as a result of:

### 1. Normal or accelerated wear and tear.

Specific items might include, but are not limited to:

- |           |                                 |
|-----------|---------------------------------|
| A. Brakes | E. Seals and Packings schedules |
| B. Belts  | F. Tires                        |
| C. Hoses  | G. Fuses                        |
| D. Bulbs  | H. Clutches                     |

### 2. Alterations, not approved by BOMAG Americas, Inc.

Including installation of "unapproved" accessories.

### 3. Abuse.

Specific examples might include, but are not limited to are:

- A. Overloading
- B. Misapplication
- C. Improper Operation and Storage
- D. Neglect

### 4. Lack of Maintenance.

Including:

- A. Failure to inspect and maintain in accordance with published schedules
- B. Improper Repair
- C. Use of "unapproved" parts

### 5. Periodic maintenance which is performed in accordance with BOMAG Americas, Inc. published schedules.

Specific items might include, but are not limited to:

- A. Tune-up Parts
- B. Filters
- C. Spark Plugs
- D. Oil/Grease, Lube/Fuel

### 6. Certain products manufactured by other suppliers are covered by warranties extended by the original product manufacturers.

Examples include, but are not limited to:

- A. Batteries
- B. Tires
- C. **Engines**
- D. Attachments and Trade Accessories