



State of West Virginia
 Department of Administration
 Purchasing Division
 2019 Washington Street East
 Post Office Box 50130
 Charleston, WV 25305-0130

Request for Quotation

RFQ NUMBER
PRI11561

PAGE
1

ADDRESS CORRESPONDENCE TO ATTENTION OF:
TARA LYLE
304-558-2544

VENDOR

RFQ COPY
 TYPE NAME/ADDRESS HERE
Matheny Motors
4125 1st Avenue
Nitro WV 25143

SHIP TO

WV PRISON INDUSTRIES
617 LEON SULLIVAN WAY
CHARLESTON, WV
25301 **304-558-2945**

DATE PRINTED	TERMS OF SALE	SHIP VIA	F.O.B.	FREIGHT TERMS		
01/09/2012						
BID OPENING DATE: 02/16/2012		BID OPENING TIME 01:30PM				
LINE	QUANTITY	UOP	CAT. NO.	ITEM NUMBER	UNIT PRICE	AMOUNT
1001	1	EA		070-53	\$79,617.00	\$79,617.00
<p>DELIVERY TRUCK</p> <p>THE WEST VIRGINIA PURCHASING DIVISION FOR THE AGENCY, WEST VIRGINIA CORRECTIONAL INDUSTRIES, IS SOLICITING BIDS FOR ONE (1) 2011 OR NEWER DELIVERY TRUCK, PER THE ATTACHED SPECIFICATIONS.</p> <p>INQUIRIES:</p> <p>WRITTEN QUESTIONS WILL BE ACCEPTED UNTIL CLOSE OF BUSINESS ON 01/31/2012. QUESTIONS MAY BE SENT VIA USPS, FAX, COURIER OR E-MAIL. IN ORDER TO ASSURE NO VENDOR RECEIVES AN UNFAIR ADVANTAGE, NO SUBSTANTIVE QUESTIONS WILL BE ANSWERED ORALLY. IF POSSIBLE, E-MAIL QUESTIONS ARE PREFERRED. ADDRESS INQUIRIES TO:</p> <p>TARA LYLE DEPARTMENT OF ADMINISTRATION PURCHASING DIVISION 2019 WASHINGTON STREET, EAST CHARLESTON, WV 25305</p> <p>FAX: 304-558-4115 EMAIL: TARA.L.LYLE@WV.GOV</p> <p>CANCELLATION: THE DIRECTOR OF PURCHASING RESERVES THE RIGHT TO CANCEL THIS CONTRACT IMMEDIATELY UPON WRITTEN NOTICE TO THE VENDOR IF THE COMMODITIES AND/OR SERVICES SUPPLIED ARE OF AN INFERIOR QUALITY OR DO NOT CONFORM</p>						

SEE REVERSE SIDE FOR TERMS AND CONDITIONS

TELEPHONE 304-769-5860 DATE 2/15/2012

ADDRESS CHANGES TO BE NOTED ABOVE

FEIN 55-032-0770

WHEN RESPONDING TO RFQ, INSERT NAME AND ADDRESS IN SPACE ABOVE I AM FILLING IN FOR 'VENDOR'

SIGNATURE *Jackie A. ...*
 TITLE Sales Consultant

GENERAL TERMS & CONDITIONS REQUEST FOR QUOTATION (RFQ) AND REQUEST FOR PROPOSAL (RFP)

1. Awards will be made in the best interest of the State of West Virginia.
2. The State may accept or reject in part, or in whole, any bid.
3. Prior to any award, the apparent successful vendor must be properly registered with the Purchasing Division and have paid the required \$125 fee.
4. All services performed or goods delivered under State Purchase Order/Contracts are to be continued for the term of the Purchase Order/Contracts, contingent upon funds being appropriated by the Legislature or otherwise being made available. In the event funds are not appropriated or otherwise available for these services or goods this Purchase Order/Contract becomes void and of no effect after June 30.
5. Payment may only be made after the delivery and acceptance of goods or services.
6. Interest may be paid for late payment in accordance with the *West Virginia Code*.
7. Vendor preference will be granted upon written request in accordance with the *West Virginia Code*.
8. The State of West Virginia is exempt from federal and state taxes and will not pay or reimburse such taxes.
9. The Director of Purchasing may cancel any Purchase Order/Contract upon 30 days written notice to the seller.
10. The laws of the State of West Virginia and the *Legislative Rules* of the Purchasing Division shall govern the purchasing process.
11. Any reference to automatic renewal is hereby deleted. The Contract may be renewed only upon mutual written agreement of the parties.
12. **BANKRUPTCY:** In the event the vendor/contractor files for bankruptcy protection, the State may deem this contract null and void, and terminate such contract without further order.
13. **HIPAA BUSINESS ASSOCIATE ADDENDUM:** The West Virginia State Government HIPAA Business Associate Addendum (BAA), approved by the Attorney General, is available online at www.state.wv.us/admin/purchase/vrc/hipaa.html and is hereby made part of the agreement provided that the Agency meets the definition of a Cover Entity (45 CFR §160.103) and will be disclosing Protected Health Information (45 CFR §160.103) to the vendor.
14. **CONFIDENTIALITY:** The vendor agrees that he or she will not disclose to anyone, directly or indirectly, any such personally identifiable information or other confidential information gained from the agency, unless the individual who is the subject of the information consents to the disclosure in writing or the disclosure is made pursuant to the agency's policies, procedures, and rules. Vendor further agrees to comply with the Confidentiality Policies and Information Security Accountability Requirements, set forth in <http://www.state.wv.us/admin/purchase/privacy/noticeConfidentiality.pdf>.
15. **LICENSING:** Vendors must be licensed and in good standing in accordance with any and all state and local laws and requirements by any state or local agency of West Virginia, including, but not limited to, the West Virginia Secretary of State's Office, the West Virginia Tax Department, and the West Virginia Insurance Commission. The vendor must provide all necessary releases to obtain information to enable the director or spending unit to verify that the vendor is licensed and in good standing with the above entities.
16. **ANTITRUST:** In submitting a bid to any agency for the State of West Virginia, the bidder offers and agrees that if the bid is accepted the bidder will convey, sell, assign or transfer to the State of West Virginia all rights, title and interest in and to all causes of action it may now or hereafter acquire under the antitrust laws of the United States and the State of West Virginia for price fixing and/or unreasonable restraints of trade relating to the particular commodities or services purchased or acquired by the State of West Virginia. Such assignment shall be made and become effective at the time the purchasing agency tenders the initial payment to the bidder.

I certify that this bid is made without prior understanding, agreement, or connection with any corporation, firm, limited liability company, partnership, or person or entity submitting a bid for the same material, supplies, equipment or services and is in all respects fair and without collusion or Fraud. I further certify that I am authorized to sign the certification on behalf of the bidder or this bid.

INSTRUCTIONS TO BIDDERS

1. Use the quotation forms provided by the Purchasing Division. Complete all sections of the quotation form.
2. Items offered must be in compliance with the specifications. Any deviation from the specifications must be clearly indicated by the bidder. Alternates offered by the bidder as **EQUAL** to the specifications must be clearly defined. A bidder offering an alternate should attach complete specifications and literature to the bid. The Purchasing Division may waive minor deviations to specifications.
3. Unit prices shall prevail in case of discrepancy. All quotations are considered F.O.B. destination unless alternate shipping terms are clearly identified in the quotation.
4. All quotations must be delivered by the bidder to the office listed below prior to the date and time of the bid opening. Failure of the bidder to deliver the quotations on time will result in bid disqualifications: Department of Administration, Purchasing Division, 2019 Washington Street East, P.O. Box 50130, Charleston, WV 25305-0130
5. Communication during the solicitation, bid, evaluation or award periods, except through the Purchasing Division, is strictly prohibited (W.Va. C.S.R. §148-1-6.6).



State of West Virginia
 Department of Administration
 Purchasing Division
 2019 Washington Street East
 Post Office Box 50130
 Charleston, WV 25305-0130

Request for Quotation

RFQ NUMBER
PRI11561

PAGE
2

ADDRESS CORRESPONDENCE TO ATTENTION OF:
TARA LYLE
304-558-2544

VENDOR
 RFQ COPY
 TYPE NAME/ADDRESS HERE
Matheny Motors
4125 1st Avenue
Nitro WV 25143

SHIP TO
WV PRISON INDUSTRIES
617 LEON SULLIVAN WAY
CHARLESTON, WV
25301
304-558-2945

DATE PRINTED 01/09/2012	TERMS OF SALE	SHIP VIA	F.O.B.	FREIGHT TERMS
BID OPENING DATE: 02/16/2012	BID OPENING TIME 01:30PM			

LINE	QUANTITY	UOP	CAT. NO.	ITEM NUMBER	UNIT PRICE	AMOUNT
<p>TO THE SPECIFICATIONS OF THE BID AND CONTRACT HEREIN.</p> <p>BANKRUPTCY: IN THE EVENT THE VENDOR/CONTRACTOR FILES FOR BANKRUPTCY PROTECTION, THE STATE MAY DEEM THE CONTRACT NULL AND VOID, AND TERMINATE SUCH CONTRACT WITHOUT FURTHER ORDER.</p> <p>THE MODEL/BRAND/SPECIFICATIONS NAMED HEREIN ESTABLISH THE ACCEPTABLE LEVEL OF QUALITY ONLY AND ARE NOT INTENDED TO REFLECT A PREFERENCE OR FAVOR ANY PARTICULAR BRAND OR VENDOR. VENDORS WHO ARE BIDDING ALTERNATES SHOULD SO STATE AND INCLUDE PERTINENT LITERATURE AND SPECIFICATIONS. FAILURE TO PROVIDE INFORMATION FOR ANY ALTERNATES MAY BE GROUNDS FOR REJECTION OF THE BID. THE STATE RESERVES THE RIGHT TO WAIVE MINOR IRREGULARITIES IN BIDS OR SPECIFICATIONS IN ACCORDANCE WITH SECTION 148-1-4(F) OF THE WEST VIRGINIA LEGISLATIVE RULES AND REGULATIONS.</p> <p>ANY INDIVIDUAL SIGNING THIS BID IS CERTIFYING THAT: (1) HE OR SHE IS AUTHORIZED BY THE BIDDER TO EXECUTE THE BID OR ANY DOCUMENTS RELATED THERETO ON BEHALF OF THE BIDDER, (2) THAT HE OR SHE IS AUTHORIZED TO BIND THE BIDDER IN A CONTRACTUAL RELATIONSHIP, AND (3) THAT THE BIDDER HAS PROPERLY REGISTERED WITH ANY STATE AGENCIES THAT MAY REQUIRE REGISTRATION.</p> <p>VENDOR PREFERENCE CERTIFICATE</p> <p>THIS TEAM EXHIBIT HAS BEEN REPLACED BY THE ONLINE VERSION WHICH IS AVAILABLE HERE: HTTP://WWW.STATE.WV.US/ADMIN/PURCHASE/VRC/VENPREF.PDF</p> <p>NOTICE</p>						

SEE REVERSE SIDE FOR TERMS AND CONDITIONS

TELEPHONE **304-769-5860** DATE **2/15/2012**

ADDRESS CHANGES TO BE NOTED ABOVE

WHEN RESPONDING TO RFQ, INSERT NAME AND ADDRESS IN SPACE ABOVE LABELED 'VENDOR'

SIGNATURE *Jack...*
 TITLE **Sales Consultant** FEIN **55-032-0770**



State of West Virginia
 Department of Administration
 Purchasing Division
 2019 Washington Street East
 Post Office Box 50130
 Charleston, WV 25305-0130

Request for Quotation

RFQ NUMBER
PRI11561

PAGE
3

ADDRESS CORRESPONDENCE TO ATTENTION OF:
TARA LYLE
304-558-2544

VENDOR

RFQ COPY
 TYPE NAME/ADDRESS HERE
Matheny Motors
4125 1st Avenue
Nitro WV 25143

SHIP TO

WV PRISON INDUSTRIES
617 LEON SULLIVAN WAY
CHARLESTON, WV
25301
304-558-2945

DATE PRINTED	TERMS OF SALE	SHIP VIA	F.O.B.	FREIGHT TERMS
01/09/2012				

BID OPENING DATE: **02/16/2012** BID OPENING TIME **01:30PM**

LINE	QUANTITY	UOP	CAT NO.	ITEM NUMBER	UNIT PRICE	AMOUNT
<p>A SIGNED BID MUST BE SUBMITTED TO:</p> <p>DEPARTMENT OF ADMINISTRATION PURCHASING DIVISION BUILDING 15 2019 WASHINGTON STREET, EAST CHARLESTON, WV 25305-0130</p> <p>THE BID SHOULD CONTAIN THIS INFORMATION ON THE FACE OF THE ENVELOPE OR THE BID MAY NOT BE CONSIDERED:</p> <p>SEALED BID</p> <p>BUYER:-----TL/32-----</p> <p>RFQ. NO.:-----PRI11561-----</p> <p>BID OPENING DATE:-----2/16/2012-----</p> <p>BID OPENING TIME:-----1:30 PM-----</p> <p>PLEASE PROVIDE A FAX NUMBER IN CASE IT IS NECESSARY TO CONTACT YOU REGARDING YOUR BID: -----304-769-5865-----</p> <p>CONTACT PERSON (PLEASE PRINT CLEARLY): -----Jack Cummings-----</p>						

SEE REVERSE SIDE FOR TERMS AND CONDITIONS

SIGNATURE: *Jack Cummings* TELEPHONE: **304-769-5860** DATE: **2/15/2012**

TITLE: **Sales Consultant** FEIN: **55-032-0770** ADDRESS CHANGES TO BE NOTED ABOVE

WHEN RESPONDING TO RFQ. INSERT NAME AND ADDRESS IN SPACE ABOVE LABELED 'VENDOR'

PRI11561**2011 or Newer Delivery Truck**

- GVWR 26,000, minimum
- Diesel engine shall be a minimum of 230 hp.
- Exhaust break w/driver controls
- AM/FM radio
- Air conditioned cab
- Transmission to be Allison 2500RDS or equal
- 6-speed automatic transmission
- Front tires 11r22.5g rated 12,350 lbs. Premium highway tread, minimum
- Rear tires 11r22.5g rated 23,000 lbs. Highway traction, minimum
- Axle ratio 3.90:1 or equal
- Wheelbase no less than 260"
- Nose cone on top of cab
- Dual fuel tanks, minimum 100 gallon total
- Dual ac/dc fuel tank heaters with manual switch to change from truck power to 110 ac power when plugged in via power cord
- Air brake system
- Rear dust shields
- Heated side mirrors
- Truck and body shall be painted white
- Driver seat shall be air suspension, high
- Passenger seat shall be two-man vinyl
- Frame mounted tool box 18"x18"x36", minimum
- On-spot chains mounted
- 24' dry freight van body
- Plywood lined 3/8" full, minimum
- Inside height 96", minimum
- Roll up rear door
- 1-1/8" hardwood floor, minimum
- Threshold steel diamond plate 1/8" x 23"
- Scuff side galvanized steel
- Translucent roof
- Two dome lights
- Two rows e-track each side
- 3300 lb capacity tuc-a-way lift gate with 80" x 48" aluminum platform or equal
- Aluminum body sides
- Fork lift package

- 1/2" plywood liner front, minimum
- Triangle kit & 5# fire extinguishers

Warranty:

All bidders must provide a copy of the manufacturer's warranty

Delivery:

Delivery costs shall be included with your bid. The truck shall be delivered to the agency with 90 days of award of this contract.

Award:

The contract will be awarded to one vendor with the lowest grand total meeting all of the specifications with the most complete bid.

PR11561 - Bid Form

Bid Form

Item #	Description	Quantity	Unit Price	Extended Amount
1	2011 or newer delivery truck per the specifications	1	79,617.00	\$ 79,617.00
			GRAND TOTAL:	\$ 79,617.00

Failure to use this form may result in disqualification

Bidder / Vendor Information:

Matheny Motors

Vendor Name:

Jack Cummings

Contact Name:

4125 1st Avenue

Address:

Nitro WV 25143

304-769-5860

Phone No.:

304-769-5865

Fax No.:

jcummings@mathenymotors.com

Email Address:

Authorized Signature:

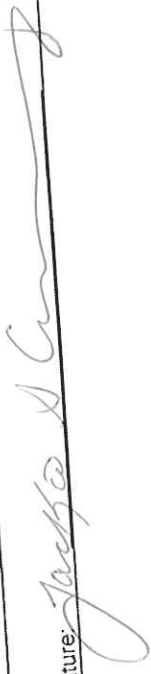

RFQ No. PRI11561

STATE OF WEST VIRGINIA
Purchasing Division

PURCHASING AFFIDAVIT

West Virginia Code §5A-3-10a states: No contract or renewal of any contract may be awarded by the state or any of its political subdivisions to any vendor or prospective vendor when the vendor or prospective vendor or a related party to the vendor or prospective vendor is a debtor and the debt owned is an amount greater than one thousand dollars in the aggregate

DEFINITIONS:

"Debt" means any assessment, premium, penalty, fine, tax or other amount of money owed to the state or any of its political subdivisions because of a judgment, fine, permit violation, license assessment, defaulted workers' compensation premium, penalty or other assessment presently delinquent or due and required to be paid to the state or any of its political subdivisions, including any interest or additional penalties accrued thereon.

"Debtor" means any individual, corporation, partnership, association, Limited Liability Company or any other form or business association owing a debt to the state or any of its political subdivisions. "Political subdivision" means any county commission; municipality; county board of education; any instrumentality established by a county or municipality; any separate corporation or instrumentality established by one or more counties or municipalities, as permitted by law; or any public body charged by law with the performance of a government function or whose jurisdiction is coextensive with one or more counties or municipalities. "Related party" means a party, whether an individual, corporation, partnership, association, limited liability company or any other form or business association or other entity whatsoever, related to any vendor by blood, marriage, ownership or contract through which the party has a relationship of ownership or other interest with the vendor so that the party will actually or by effect receive or control a portion of the benefit, profit or other consideration from performance of a vendor contract with the party receiving an amount that meets or exceeds five percent of the total contract amount.

EXCEPTION: The prohibition of this section does not apply where a vendor has contested any tax administered pursuant to chapter eleven of this code, workers' compensation premium, permit fee or environmental fee or assessment and the matter has not become final or where the vendor has entered into a payment plan or agreement and the vendor is not in default of any of the provisions of such plan or agreement.

Under penalty of law for false swearing (*West Virginia Code §61-5-3*), it is hereby certified that the vendor affirms and acknowledges the information in this affidavit and is in compliance with the requirements as stated.

WITNESS THE FOLLOWING SIGNATURE

Vendor's Name: Matheny Motors

Authorized Signature: *[Signature]* Date: 2/15/2012

State of WV

County of Putnam, to-wit:

Taken, subscribed, and sworn to before me this 15th day of FEBRUARY, 2012.

My Commission expires Nov. 9, 2021.

NOTARY PUBLIC *[Signature]*

AFFIX SEAL HERE



Rev. 09/08

State of West Virginia VENDOR PREFERENCE CERTIFICATE

Certification and application* is hereby made for Preference in accordance with *West Virginia Code*, §5A-3-37. (Does not apply to construction contracts). *West Virginia Code*, §5A-3-37, provides an opportunity for qualifying vendors to request (at the time of bid) preference for their residency status. Such preference is an evaluation method only and will be applied only to the cost bid in accordance with the *West Virginia Code*. This certificate for application is to be used to request such preference. The Purchasing Division will make the determination of the Resident Vendor Preference, if applicable.

1. Application is made for 2.5% resident vendor preference for the reason checked:
 Bidder is an individual resident vendor and has resided continuously in West Virginia for four (4) years immediately preceding the date of this certification; or,
 Bidder is a partnership, association or corporation resident vendor and has maintained its headquarters or principal place of business continuously in West Virginia for four (4) years immediately preceding the date of this certification; or 80% of the ownership interest of Bidder is held by another individual, partnership, association or corporation resident vendor who has maintained its headquarters or principal place of business continuously in West Virginia for four (4) years immediately preceding the date of this certification; or,
 Bidder is a nonresident vendor which has an affiliate or subsidiary which employs a minimum of one hundred state residents and which has maintained its headquarters or principal place of business within West Virginia continuously for the four (4) years immediately preceding the date of this certification; or,
2. Application is made for 2.5% resident vendor preference for the reason checked:
 Bidder is a resident vendor who certifies that, during the life of the contract, on average at least 75% of the employees working on the project being bid are residents of West Virginia who have resided in the state continuously for the two years immediately preceding submission of this bid; or,
3. Application is made for 2.5% resident vendor preference for the reason checked:
 Bidder is a nonresident vendor employing a minimum of one hundred state residents or is a nonresident vendor with an affiliate or subsidiary which maintains its headquarters or principal place of business within West Virginia employing a minimum of one hundred state residents who certifies that, during the life of the contract, on average at least 75% of the employees or Bidder's affiliate's or subsidiary's employees are residents of West Virginia who have resided in the state continuously for the two years immediately preceding submission of this bid; or,
4. Application is made for 5% resident vendor preference for the reason checked:
 Bidder meets either the requirement of both subdivisions (1) and (2) or subdivision (1) and (3) as stated above; or,
5. Application is made for 3.5% resident vendor preference who is a veteran for the reason checked:
 Bidder is an individual resident vendor who is a veteran of the United States armed forces, the reserves or the National Guard and has resided in West Virginia continuously for the four years immediately preceding the date on which the bid is submitted; or,
6. Application is made for 3.5% resident vendor preference who is a veteran for the reason checked:
 Bidder is a resident vendor who is a veteran of the United States armed forces, the reserves or the National Guard, if, for purposes of producing or distributing the commodities or completing the project which is the subject of the vendor's bid and continuously over the entire term of the project, on average at least seventy-five percent of the vendor's employees are residents of West Virginia who have resided in the state continuously for the two immediately preceding years.

Bidder understands if the Secretary of Revenue determines that a Bidder receiving preference has failed to continue to meet the requirements for such preference, the Secretary may order the Director of Purchasing to: (a) reject the bid; or (b) assess a penalty against such Bidder in an amount not to exceed 5% of the bid amount and that such penalty will be paid to the contracting agency or deducted from any unpaid balance on the contract or purchase order.

By submission of this certificate, Bidder agrees to disclose any reasonably requested information to the Purchasing Division and authorizes the Department of Revenue to disclose to the Director of Purchasing appropriate information verifying that Bidder has paid the required business taxes, provided that such information does not contain the amounts of taxes paid nor any other information deemed by the Tax Commissioner to be confidential.

Under penalty of law for false swearing (*West Virginia Code*, §61-5-3), Bidder hereby certifies that this certificate is true and accurate in all respects; and that if a contract is issued to Bidder and if anything contained within this certificate changes during the term of the contract, Bidder will notify the Purchasing Division in writing immediately.

Bidder: Matheny Motors
Date: 2/15/2012

Signed: 
Title: Sales Consultant

*Check any combination of preference consideration(s) indicated above, which you are entitled to receive.



State of West Virginia
 Department of Administration
 Purchasing Division
 2019 Washington Street East
 Post Office Box 50130
 Charleston, WV 25305-0130

Request for Quotation

RFQ NUMBER
PRI11561

PAGE
1

ADDRESS CORRESPONDENCE TO ATTENTION OF:
TARA LYLE
304-558-2544

VENDOR

RFQ COPY
 TYPE NAME/ADDRESS HERE
Matheny Motors
4125 1st Avenue
Nitro WV 25143

SHIP TO

WV PRISON INDUSTRIES
617 LEON SULLIVAN WAY
CHARLESTON, WV
25301
304-558-2945

DATE PRINTED	TERMS OF SALE	SHIP VIA	F.O.B.	FREIGHT TERMS		
01/31/2012						
BID OPENING DATE: 02/16/2012		BID OPENING TIME: 01:30PM				
LINE	QUANTITY	UOP	CAT. NO.	ITEM NUMBER	UNIT PRICE	AMOUNT
0001	1	EA		070-53	\$79,617.00	\$79,617.00
ADDENDUM NO. 1 1. QUESTIONS AND ANSWERS ARE ATTACHED. 2. ADDENDUM ACKNOWLEDGEMENT IS ATTACHED. THIS DOCUMENT SHOULD BE SIGNED AND RETURNED WITH YOUR BID. FAILURE TO SIGN AND RETURN MAY RESULT IN DISQUALIFICATION OF YOUR BID. END OF ADDENDUM NO. 1 DELIVERY TRUCK ***** THIS IS THE END OF RFQ PRI11561 ***** TOTAL:						
SEE REVERSE SIDE FOR TERMS AND CONDITIONS					TELEPHONE	DATE
					304-769-5860	2/15/2012
SIGNATURE		FEIN		ADDRESS CHANGES TO BE NOTED ABOVE		
<i>Jacko A. [Signature]</i>		55-032-0770				
TITLE Sales Consultant						
WHEN RESPONDING TO RFQ INSERT NAME AND ADDRESS IN SPACE ABOVE LABELLED 'VENDOR'						

GENERAL TERMS & CONDITIONS
REQUEST FOR QUOTATION (RFQ) AND REQUEST FOR PROPOSAL (RFP)

1. Awards will be made in the best interest of the State of West Virginia.
 2. The State may accept or reject in part, or in whole, any bid.
 3. Prior to any award, the apparent successful vendor must be properly registered with the Purchasing Division and have paid the required \$125 fee.
 4. All services performed or goods delivered under State Purchase Order/Contracts are to be continued for the term of the Purchase Order/Contracts, contingent upon funds being appropriated by the Legislature or otherwise being made available. In the event funds are not appropriated or otherwise available for these services or goods this Purchase Order/Contract becomes void and of no effect after June 30.
 5. Payment may only be made after the delivery and acceptance of goods or services.
 6. Interest may be paid for late payment in accordance with the *West Virginia Code*.
 7. Vendor preference will be granted upon written request in accordance with the *West Virginia Code*.
 8. The State of West Virginia is exempt from federal and state taxes and will not pay or reimburse such taxes.
 9. The Director of Purchasing may cancel any Purchase Order/Contract upon 30 days written notice to the seller.
 10. The laws of the State of West Virginia and the *Legislative Rules* of the Purchasing Division shall govern the purchasing process.
 11. Any reference to automatic renewal is hereby deleted. The Contract may be renewed only upon mutual written agreement of the parties.
 12. **BANKRUPTCY:** In the event the vendor/contractor files for bankruptcy protection, the State may deem this contract null and void, and terminate such contract without further order.
 13. **HIPAA BUSINESS ASSOCIATE ADDENDUM:** The West Virginia State Government HIPAA Business Associate Addendum (BAA), approved by the Attorney General, is available online at www.state.wv.us/admin/purchase/vrc/hipaa.html and is hereby made part of the agreement provided that the Agency meets the definition of a Cover Entity (45 CFR §160.103) and will be disclosing Protected Health Information (45 CFR §160.103) to the vendor.
 14. **CONFIDENTIALITY:** The vendor agrees that he or she will not disclose to anyone, directly or indirectly, any such personally identifiable information or other confidential information gained from the agency, unless the individual who is the subject of the information consents to the disclosure in writing or the disclosure is made pursuant to the agency's policies, procedures, and rules. Vendor further agrees to comply with the Confidentiality Policies and Information Security Accountability Requirements, set forth in <http://www.state.wv.us/admin/purchase/privacy/noticeConfidentiality.pdf>.
 15. **LICENSING:** Vendors must be licensed and in good standing in accordance with any and all state and local laws and requirements by any state or local agency of West Virginia, including, but not limited to, the West Virginia Secretary of State's Office, the West Virginia Tax Department, and the West Virginia Insurance Commission. The vendor must provide all necessary releases to obtain information to enable the director or spending unit to verify that the vendor is licensed and in good standing with the above entities.
 16. **ANTITRUST:** In submitting a bid to any agency for the State of West Virginia, the bidder offers and agrees that if the bid is accepted the bidder will convey, sell, assign or transfer to the State of West Virginia all rights, title and interest in and to all causes of action it may now or hereafter acquire under the antitrust laws of the United States and the State of West Virginia for price fixing and/or unreasonable restraints of trade relating to the particular commodities or services purchased or acquired by the State of West Virginia. Such assignment shall be made and become effective at the time the purchasing agency tenders the initial payment to the bidder.
- I certify that this bid is made without prior understanding, agreement, or connection with any corporation, firm, limited liability company, partnership, or person or entity submitting a bid for the same material, supplies, equipment or services and is in all respects fair and without collusion or fraud. I further certify that I am authorized to sign the certification on behalf of the bidder or this bid.

INSTRUCTIONS TO BIDDERS

1. Use the quotation forms provided by the Purchasing Division. Complete all sections of the quotation form.
2. Items offered must be in compliance with the specifications. Any deviation from the specifications must be clearly indicated by the bidder. Alternates offered by the bidder as EQUAL to the specifications must be clearly defined. A bidder offering an alternate should attach complete specifications and literature to the bid. The Purchasing Division may waive minor deviations to specifications.
3. Unit prices shall prevail in case of discrepancy. All quotations are considered F.O.B. destination unless alternate shipping terms are clearly identified in the quotation.
4. All quotations must be delivered by the bidder to the office listed below prior to the date and time of the bid opening. Failure of the bidder to deliver the quotations on time will result in bid disqualifications: Department of Administration, Purchasing Division, 2019 Washington Street East, P.O. Box 50130, Charleston, WV 25305-0130
5. Communication during the solicitation, bid, evaluation or award periods, except through the Purchasing Division, is strictly prohibited (W.Va. C.S.R. §148-1-6.6).

PRI11561
Addendum # 1

QUESTIONS:

Q1: Axle Ratio to be 3.90:1; statement should be corrected to reflect the top miles per hour that you would like the unit to run. Ratios for each engine vary by this selection and maximum engine RPM's assigned to that engine. Thus, road speed will dictate ratio.

A1: 70 miles per hour.

Q2: Wheelbase no less than 260"; Cab to axle dimensions are normally utilized to best meet the body being installed; 24 foot bodies normally require something in the 186" CA range. Wheelbases vary from manufacturer to manufacturer. But the correct CA will be in this range.

A2: 186" CA range is acceptable.

Q3: Dual fuel tanks, minimum 100 gal. total; We suggest adding the verbiage "Aluminum" to this specification. Steel fuel tanks do not weather well in our environment (rust and corrosion) and new low sulphur fuels also take a toll on the inside of the steel tanks over time.

A3: Change the fuel tank specification from steel to aluminum.

Q4: Dual ac/dc fuel tank heaters with manual switch to change from truck power to 110 ac power when plugged in via power cord; we suggest using "Heated Fuel Water Separator" in lieu of the ac/dc fuel tank heater. Winter environment in West Virginia does not require such radical fuel heaters and the change can save the division money on the purchase.

A4: Agency will not change this specification. Our trucks travel the entire state and in the past we have had freezing issues in the Huttonsville, Martinsburg areas as well as other areas of the State. We must have the ac/dc fuel tank heaters.

The bid opening remains 2/16/2012 at 1:30 pm.

No additional questions will be accepted on this RFQ.

EXHIBIT 10

PRI11561

REQUISITION NO.:

ADDENDUM ACKNOWLEDGEMENT

I HEREBY ACKNOWLEDGE RECEIPT OF THE FOLLOWING CHECKED
ADDENDUM(S) AND HAVE MADE THE NECESSARY REVISIONS TO MY
PROPOSAL, PLANS AND/OR SPECIFICATION, ETC.

ADDENDUM NO.'S:

NO. 1 ^X

NO. 2

NO. 3

NO. 4

NO. 5

I UNDERSTAND THAT FAILURE TO CONFIRM THE RECEIPT OF THE
ADDENDUM(S) MAY BE CAUSE FOR REJECTION OF BIDS. VENDOR
MUST CLEARLY UNDERSTAND THAT ANY VERBAL
REPRESENTATION MADE OR ASSUMED TO BE MADE DURING ANY
ORAL DISCUSSION HELD BETWEEN VENDOR'S REPRESENTATIVES
AND ANY STATE PERSONNEL IS NOT BINDING. ONLY THE
INFORMATION ISSUED IN WRITING AND ADDED TO THE
SPECIFICATIONS BY AN OFFICIAL ADDENDUM IS BINDING.

.....
SIGNATURE

Matheny Motors

.....

COMPANY

2/15/2012

.....

DATE

REV. 11/96



MATHENY MOTOR TRUCK CO.

Established 1922

3rd & Ann Streets • P.O. Box 1304

Parkersburg, WV 26102

(304) 485-4418 • (304) 485-2577 fax

www.mathenymotors.com

February 15, 2012

Tara Lyle
Department of Administration
Purchasing Division
2019 Washington St East
Charleston, WV 25305

RE: PRI11561

Ms. Lyle,

Thank you for this opportunity to submit a proposal on your vehicle needs. Please find attached the warranty information, standards list, and invoice for a 2011 Hino that we currently have in stock. This vehicle meets or exceeds your specs with the following exceptions:

GVW – 25,950
Engine HP – 220
Transmission – 2200 RDS
Fuel Tank – Single 52 Gallon
No dust shields on rear brakes
No heated mirrors

Please also find attached a copy of the box specs, warranty information and lift gate information.

A handwritten signature in cursive script, appearing to read "Jack Cummings", is written over the typed name and title.

Jack Cummings (Commercial Sales Consultant)
Matheny Commercial Trucks
4125 1st Avenue
Nitro, WV 25143
Office 304-769-5860
Fax 304-769-5865
Cell 304-539-3817
www.mathenymotors.com

PONTIAC BUICK

GMC

SUZUKI



HINO TRUCKS
A Hino Group Company



JERR-DAN
A Daimler Truck Corporation Company



ACN Number:	06-1119075
Invoice Number:	9 0029603
Order Number:	633601
Invoice Date:	09/22/10
Due Date:	10/02/10
Page Number:	1

Vehicle Invoice

Ship Date: 09/22/10

Dealer Address:

Remit To:

Ship To:

HINO TRUCKS OF WILLIAMSTO
THIRD AND ANN STREETS
PO BOX 1304
PARKERSBURG, WV 26102

Will Call
Customer pick up
Pick up WV

VIN NUMBER: 5PVNJ8JT4B4S52937	DEALER CODE: 84710	TERMS OF PAYMENT: 10 Days
-------------------------------	--------------------	---------------------------

Finance	TOYOTA FINANCIAL SERVICES	Key code	73396
Dealer Order #	MMT Stock	Engine Code	10655
Reference #		Transmission code	6311009120

Code	Description	Suggested Retail
268A-11	2011 HINO 268A GVWR 25,950LBS	65598.00
BATZB	Battery-GR31	103.00
CLDS	Cold Package	459.00
HORZA	Air Horn	106.00
KB7RDS	Auto-Allison 2200RDS (PTO)	3845.00
PWDL	Power Windows & Door Locks	470.00
RSHOCK	Shocks-Rear	433.00
R529AT	Rear Axle Ratio 5.29AT	
SAFETY KIT-LO	Safety Kit - Fire Ext/Triangle	113.00
SEAT70DF-LO	Seats-Sears70 FabricDriveronly	783.00
T	253" WB / 185.6" CA	
Z01AB	Synthetic Fluids-Allison Trans	268.00
TOTAL VEHICLE AND OPTIONS		\$72,178.00
07 EMISSION SURCHARGE		\$6,700.00
FREIGHT CHARGES		\$1,525.00
INVOICE TOTAL		\$80,403.00
MFR FLOOR PLAN		180 DAYS
EXPIRES		03/21/11



“ The design of the Hino cab provides great visibility for inspecting overhead distribution lines. The Hino handles exceptionally well. ”
CENTER POINT ENERGY, HOUSTON, TEXAS

TRUCKS | DEALERS | FINANCE | PARTS | SERVICE | BUSINESS IN MOTION | PARTNERS | ABOUT HINO | NEWS | SEARCH | CONTACT HINONET
TRUCKS | 2012 MODELS | 2011 MODELS | 2010 MODELS | 2009 MODELS | 2008 MODELS | PREOWNED

CLASS 6 238 | 258ALP | 258LP | 268 | 268A CLASS 7 338 | 338 CT CLASS 4 155 CLASS 5 195 LEARN MORE >>

HINO MODEL 268A

DIMENSIONS >

CHASSIS WEIGHTS >

POWERLINE & PERFORMANCE >

ENGINE >

WEIGHT CAPACITIES >

LIQUID CAPACITIES >

AXLE / SUSPENSION >

FRAME >

STEERING >

BRAKES >

CLUTCH >

WHEELS / TIRES >

CAB EQUIPMENT >

DASH INSTRUMENTATION >

ELECTRICAL EQUIPMENT >

CHASSIS EQUIPMENT >

OPTIONS >

NOTES >

2012 MODEL COMPARISON [.xls]

DOWNLOAD PDF > MODEL SPECS

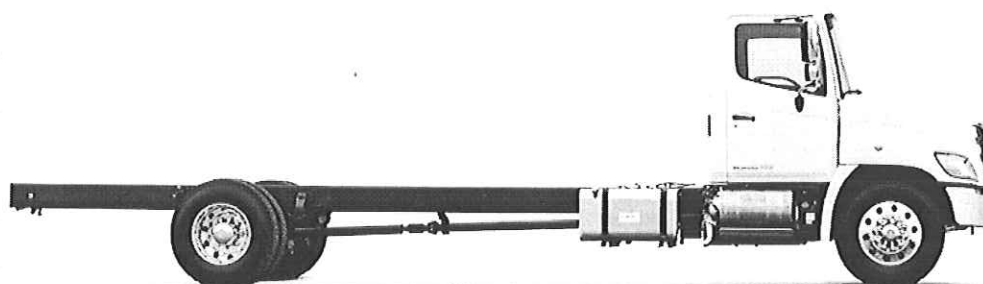

AT A GLANCE:
25950 GVW Hino 268A medium-duty truck

NOTE : All specifications of the products are within normal manufacturing allowances and tolerances. Hino Motors Sales U.S.A., Inc. reserves the right to alter specifications at any time without previous notice. Some optional items of equipment may require extra time due to the need for their adaptation on the product line.

DIMENSIONS									
Wheelbase	A in.	152/G	175/J	187/L	205/M	217/P	235/R	253/T	271/V
Overall length	B in.	242.6	278.6	302.6	320.6	354.6	372.6	390.6	390.6
Overall width	C in.	96.3	96.3	96.3	96.3	96.3	96.3	96.3	96.3
Overall height	D in.	106.5	106.5	106.5	106.5	106.5	106.5	106.5	106.5
Cab to axle	E in.	84.6	107.6	119.6	137.6	149.6	167.6	185.6	203.6
Rear overhang	F in.	50.0	63.0	75.0	75.0	97.0	97.0	97.0	79.0
Frame height at									
Front axle	G in.	36.4	36.4	36.4	36.4	36.4	36.4	36.4	36.4
Rear axle	H in.	40.0	40.0	40.0	40.0	40.0	40.0	40.0	40.0
Road clearance (at diff. axle)	J in.	11.2	11.2	11.2	11.2	11.2	11.2	11.2	11.2
Tread									
Front	K in.	79.3	79.3	79.3	79.3	79.3	79.3	79.3	79.3
Rear	L in.	72.2	72.2	72.2	72.2	72.2	72.2	72.2	72.2
Turning radius									
Curb to Curb	ft.	42.0	47.5	50.5	54.7	57.7	62.1	66.4	70.8
Wall to Wall	ft.	45.4	50.9	53.9	58.7	61.1	65.5	69.8	74.2

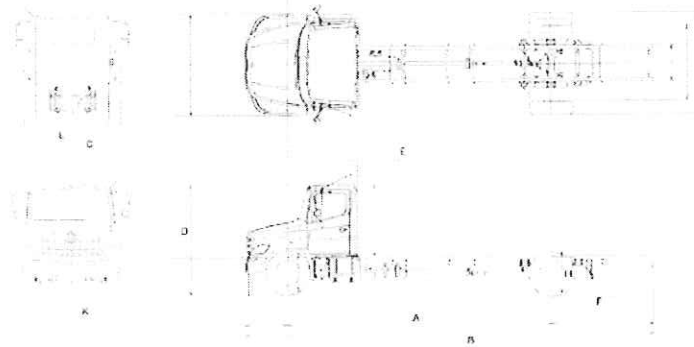

[Return to top ↑](#)

CHASSIS WEIGHTS (On standard specification, without spare tire & standard tool set)										
GVW	Total weight	lb.	9,950	9,900	9,960	10,060	10,170	10,240	10,270	10,320
	Front axle	lb.	6,035	6,205	6,265	6,365	6,400	6,490	6,515	6,650
	Rear axle	lb.	3,915	3,695	3,695	3,695	3,770	3,750	3,725	3,670

[Return to top ↑](#)

POWERTRAIN AND PERFORMANCE						
25,950 lbs. GVW						
Powertrain		STD	OPT	OPT	OPT	OPT
Max. speed mph		78	85	82	78	85
Startability (tan.0) %		34.3	31.2	32.3	39.6	36.0
Transmission	Model	Allison 2200 HS/RDS			Allison 2500 RDS	
	Type	Six-speed automatic			Six-speed automatic	
Ratios	1st	3.102			3.512	
	2nd	1.811			1.896	
	3rd	1.406			1.439	
	4th	1.000			1.000	
	5th	0.712			0.737	
	6th	0.610			0.640	
	Rev	4.492			5.086	
Rear Axle Gear Ratios		5.57	5.13	5.29	5.57	5.13
Tires (standard)		11R22.5-14				

* Max speed is limited by speed limiter.

[Return to top ↑](#)

ENGINE	
Model	J08E-VC
Type	Diesel 4-cycle, 6-cylinder in-line water-cooled, dry cylinder line
Combustion system	Direct injection type
Max. output (SAE Gross)	220HP at 2,500 rpm
Max. torque (SAE Gross)	520 lb.-ft. at 1,500 rpm
Bore and stroke	4.41 x 5.12 in.
Piston displacement	8L
Fuel injection system	Common rail (HP-4)
Governor	Electronically controlled
Intake system	Turbocharged and intercooled
Air cleaner	Paper filter type (Donaldson)
Fan clutch	Bimetal thermostat sensor regulates fan speed
Glow plugs	Standard
Air compressor	Single cylinder, 10.3 cfm @ 1,250 rpm

HINOWATCH (service free of charge)	
3 year unlimited roadside assistance	
<ul style="list-style-type: none"> • Lockout Service • Battery Jumpstart • Information • Warranty Towing (2 year coverage) 	

[Return to top ↑](#)

WEIGHT CAPACITIES		
Front axle	lbs.	10,000
Rear axle	lbs.	19,000
Front spring	lbs.	12,000
Rear spring	lbs.	21,000

LIQUID CAPACITIES		
Fuel tank	gal.	52
Cooling system	gal.	6.6; Allison 2200HS
Engine oil	qt.	16.2
DEF tank	gal.	4.7

AXLE / SUSPENSION	
Front axle	MFS-10 series reversed Elliot, "I" beam (oil lubricated type)
Front spring	Taper-leaf springs shock absorber
Rear axle	RS19-145 series, full-floating, single reduction, single-speed by hypoid gearings with oil lubricated type
Rear spring	Semi-elliptic air spring with shock absorbers

[Return to top ↑](#)

FRAME		
Ladder type		Straight C Channel
Width	in.	34
Yield strength	PSI	80,000
Resisting bending moment (one side)	in.-lbs.	1,031,900 (no reinforcement)

STEERING	
Steering column	Tilt and telescopic with lock adjustability
Steering system	TRW recirculating ball, with hydraulic booster, integral type

[Return to top ↑](#)

BRAKES	
Service brake	Full air, dual circuit, "S" cam type, leading and trailing shoes, with automatic adjustment
Disc diameter x pad area (in. ²) x thickness (in.)	Front: 15 x 4 x 0.73 Rear: 16.5 x 7 x 0.85
Control	Full air dual circuit with Antilock Brake System (ABS)
Parking brake	Spring brake acting on rear wheels
Exhaust brake	Electric-pneumatic with valve in exhaust pipe

[Return to top ↑](#)

WHEELS / TIRES	
6 Wheels	22.5 x 8.25 10- stud disc.
Wheel style	Steel, powder coated
6 Tires	11R22.5(G)
Tire pattern	Fr-rib Rr-lug type

CAB EQUIPMENT	
Air conditioning	Standard
Cab construction	All steel welded
Cigarette lighter	Equipped
Coat hook	One (rear panel)
Cruise control	Standard
Cup holders	Standard
Door pockets	Two
Driver's seat	2-way adjustable seat with arm rest and air suspension, covered with vinyl
Heater/Defroster	18,357 BTU/h
Mirrors	Four, 1-flat and 1-convex at each side
Overhead consoles	Two
Passenger's seat	Bench type, covered with vinyl
Seat belts	3-point type (driver and passenger), one 2-point type (center)
Seating capacity	Three
Speakers	Two
Sun visors	Two
Ventilator	Electric forced air
Windshield	Laminated
Windshield wipers	Dual electric, 2-speed/intermittent

[Return to top ↑](#)

DASH INSTRUMENTATION	
Meters and gauges ft. lb. system	
Speedometer-mph (km/h)	
Odometer (mile)	
Fuel gauge / DEF gauge	
Coolant temperature gauge	
Engine tachometer	
Warning and pilot lamps and buzzers/audio	
Oil pressure warning lamp and buzzer	
Brake pressure warning lamp and buzzer	
Coolant level warning lamp and buzzer	
Battery charging warning lamp	
High beam indicator lamp	
Turn signal pilot lamp	
Parking brake warning lamp	
Engine control system warning lamp	
ABS warning lamp	
DEF quantity and quality audio	
Driver Information Display (multilingual)	
Instant and trip fuel consumption	
DPR monitor	
Maintenance	
Engine/vehicle diagnostics	

[Return to top ↑](#)

ELECTRICAL EQUIPMENT	
Batteries	Two, parallel connection, each 12V
Capacity	1200 CCA
Alternator	12 V, 130 A, brush Delco
Starter	12 V, 4.0 kW Denso
Stereo	AM/FM radio with CD
Headlamps	Daytime running
Back-up lamps	
Dome lamp	
Electric horn (dual)	
Front side marker lamps	
Side-flasher lamp	
Stop/Tail lamps	
Trucklite LED marker lamps (front)	

[Return to top ↑](#)

CHASSIS EQUIPMENT	
Radiator grille	Chrome
Fuel tank	Aluminum
Fuel pre-filter	Heated pre-filter (dust) and sedimenter (water)
Reflectors	Two rear, two front side
Tow hook	One at front
Air dryer	Bendix, heated
Air tank	68L

[Return to top ↑](#)

OPTIONAL EQUIPMENT	
Air horn	
Air ride suspension - Hendrickson	
Air ride suspension dump valve - Electric	
Alternator - 12 V, 135 A, brushless Delco	
Anti-Siphon device insert in fuel tank	
Back-up aid alarm	
Battery - Absorbed glass mat 31 configuration, 1850 CCA	
Battery - Three parallel connection each 12 V (GR27x3)	
Battery - Two or three parallel connection each 12 V (GR31 type)	
Bumper, front - Black and 4 inch extension (available 3 piece)	
Bumper, front - White and 4 inch extension (available 3 piece)	
Bumper, front - White 3 piece (available with 1 or 2 tow hooks)	
Bumper, front - Chrome and 4 inch extension	
Bumper, front - Chrome (available with 1 or 2 tow hooks)	
Cab paint, exterior - Black or red (factory)	
Cab paint, exterior - Additional options available upon request	
Cold weather package - Power heated mirrors (available in chrome) - Engine block heater	
Differential lock with controls	
Engine block heater	
Engine idle shutdown	
Exhaust system - Vertical stack type	
Fuel tank - Dual 52 gal	
Fuel tank - Single 95 gal.	
Keyed alike - Matching key codes	
Mirrors, fender - Chrome (both sides or passenger only)	
Mirrors, outside rearview - Chrome	
Mirrors, power heated (available in Chrome)	
Power windows and power door locks (available with keyless entry)	
Seats - Fabric with reclining single person passenger seat	
Seats - Vinyl with reclining single person passenger seat	
Seats - Fabric with two person bench seat	
Seats seat - Vinyl black or fabric black/silver (upgrade driver seat only or with passenger seat upgrade)	
Shock absorbers, rear	
Stabilizer, rear (leaf suspension only)	
Synthetic fluids - Auto transmission and rear differential	
Tire pattern - Rib on rear	
Tire size - 255/70R22.5-16(H)	
Tire size - 295/75R22.5-14(G)	
Tire size - 255/80R22.5-14(G)	
Transmission, automatic - Allison 2200 RDS	
Transmission, automatic - Allison 2500 RDS	
Wheels - Alcoa polished aluminum	
Wheels - Powder coated gray	

[Return to top ↑](#)

CAB CONFIGURATION OPTIONS	
Extended cab	30" cab extension, available with full width bench seat or 26" day bunk
Clean Chassis CA	Standard with 50 gal fuel tank mounted under cab (driver side)
Righ hand drive, dual-steer sit down	Driver controls mounted on both sides of cab

NOTES

All specifications of the products are with normal manufacturing allowances and tolerances. Hino Motors Sales U.S.A., Inc. reserves the right to alter specifications at any time without previous notice. Some optional items of equipment may require extra time due to the need for their adaption on the product line.

[Return to top ↑](#)



TERMS | PRIVACY ©2009 HINO MOTORS SALES U.S.A., INC.

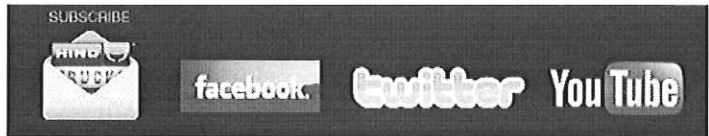

STAY UP TO DATE WITH OUR NEWSLETTER OR BY FOLLOWING US ON THESE SITES

2012 MODELS

Medium Duty Trucks:
238 / 258ALP / 258LP
268 / 268A
338 / 338CT

2011 MODELS

Medium Duty Trucks:
238 / 258ALP / 258LP
268 / 268A
338 / 338CT

2010 MODELS

Light Duty Trucks:
145
165
Medium Duty Trucks:
185
238 / 258ALP / 258LP
268 / 268A
338 / 338CT

PREOWNED TRUCKS

Hino Preowned Trucks Listings

TRUCK DEALERS

All Dealers/Search
Truck Dealers by State:
Alabama
Arizona
Arkansas
California
Colorado
Connecticut
Delaware
Florida
Georgia
Guam
Hawaii
Illinois
Indiana
Iowa
Kansas
Kentucky
Louisiana
Maine
Maryland
Massachusetts
Michigan
Minnesota
Mississippi
Missouri
Nebraska
New Hampshire
New Jersey
New Mexico
New York
North Carolina
Ohio
Oklahoma
Oregon
Pennsylvania
Puerto Rico
Rhode Island
South Dakota
Tennessee
Texas
Utah
Vermont
Virginia
Washington
West Virginia
Wisconsin

PARTS

Distribution Center
Promotions
Genuine Parts
Literature
Hino Style Parts
Parts Downloads:
2009-2010 quick ref card
2005-2008 quick ref guide
1998-2004 quick ref guide
1984-1997 quick ref guide
Hino Style accessories guide

SERVICE

Warranty
HinoWatch
Publications
Service Info Available Off-Site:
Service Information
Diagnostic Equipment
Body Builder Manuals
Online Service Information

BUSINESS IN MOTION

Hino Engines
Hino Driveline
Hino Cab Design
Hino Serviceability
Case Studies
EPA 2010
Case Studies:
Dump Truck
Utility Truck
Box Truck
Aerial Device / Bucket Truck
Refuse Collection
Roll Back / Tow Truck
Available Off-Site:
HinoSCR.com

PARTNERS

Transmissions
Suspension
Tires
Axles
Wheels

ABOUT HINO

Hino History
Hino & Toyota
Hino Assembly
Our Mission

NEWS

Latest News
News Archives
Media and PR

EVENTS

Events List
Available Off-Site:
HinoEvents.com

CONTACT US

Direct Access Directory
Email
Become A Dealer
Careers
Facebook
Twitter
Youtube

SPECIAL ANNOUNCEMENTS

Fraudulent Email Advisory

EXTERNAL HINO SITES

HinoEvents.com
HinoSCR.com
HinoInsight.com
HinoPreownedTrucks.com

WARRANTY COVERAGE



A Toyota Group Company

2012MY 4 x 2 CONVENTIONAL HINO TRUCKS

DESCRIPTION	MONTHS	MILEAGE
BASIC VEHICLE Provides warranty coverage against defects in material and workmanship for 24 months / unlimited mileage. Includes towing to the nearest Hino dealer for warrantable failures. (Adjustments and expendables such as bulbs and fuses are covered for 90 days / 3,000 miles. Batteries are covered for 12 months / unlimited mileage).	24	Unlimited
BASE ENGINE Provides warranty coverage against defects in material and workmanship for 36 months / unlimited miles for the cylinder block, cylinder head, water pump, intake and exhaust manifold, injection supply pump, engine fuel injectors, turbocharger, and all internal engine components.	36	Unlimited
EXTENDED ENGINE Provides warranty coverage against defects in material and workmanship for 60 months / 250,000 miles for camshaft, camshaft housing, connecting rod, crankshaft, cylinder block, cylinder head and cover, flywheel housing, intake manifold, intake pipe, oil pump, pistons, liners, piston pins, timing gears, engine fuel injectors, fuel injection supply pump and turbocharger.	60	250,000
EMISSION WARRANTY Provides warranty coverage against defects in material and workmanship for 60 months / 100,000 miles, whichever occurs first, for the emission control system.	60	100,000
FRAME RAILS & CROSS MEMBERS Provides warranty coverage against structural cracks in the frame caused by defects in material and workmanship for 48 months / unlimited mileage.	48	Unlimited
CAB Provides warranty coverage against corrosion perforation of the cab structure for 48 months / unlimited mileage.	48	Unlimited
AUTOMATIC TRANSMISSION: ALLISON 2000 SERIES Warranty covers repairs and / or replacement at Allison Transmission's option to correct any transmission malfunction resulting from defects in material or workmanship occurring during the period. Allison Transmissions are warranted by the manufacturer for the time and mileage specified.	36	Unlimited
AUTOMATIC TRANSMISSION: ALLISON 3000 SERIES Warranty covers repairs and / or replacement at Allison Transmission's option to correct any transmission malfunction resulting from defects in material or workmanship occurring during the period. Allison Transmissions are warranted by the manufacturer for the time and mileage specified.	24	Unlimited
ANTI-LOCK BRAKING SYSTEM (ABS) AIR/HYDRAULIC Upon expiration of the Basic Vehicle Warranty (24 months), the ABS will continue to be covered for up to 36 months / 300,000 miles, whichever occurs first.	24-36	300,000

Hino reserves the right to amend all warranty terms and conditions.

**"HIGHEST IN CUSTOMER SATISFACTION WITH CONVENTIONAL MEDIUM DUTY ENGINES, THREE YEARS IN A ROW."
AND "HIGHEST IN CUSTOMER SATISFACTION WITH CONVENTIONAL MEDIUM DUTY TRUCKS."**

1. Hino received the highest numerical score among conventional medium duty engines and transmissions in the proprietary LD, Power and Kinetics 2008-2009 Medium Duty Truck Engine and Transmission Customer Satisfaction Study™. Study based on responses from 1,225 respondents, measuring 5 manufacturers. Survey was of primary maintainers and owner/operators and measures opinions of primary maintainers of two-year-old (by model year) Medium Duty (Class 5, 6, and 7) trucks. Proprietary study results are based on experiences and perceptions of consumers surveyed in June-August 2010. Your experiences may vary. Visit www.hino.com.

2. Hino received the highest numerical score among conventional medium duty trucks in the proprietary LD, Power and Kinetics 2010 Medium Duty Truck Engine and Transmission Customer Satisfaction Study™. Study based on responses from 1,218 respondents, measuring 8 manufacturers. Survey was of primary maintainers and owner/operators and measures opinions of primary maintainers of two-year-old (by model year) Medium Duty (Class 5, 6, and 7) trucks (2009 model year). Proprietary study results are based on experiences and perceptions of consumers surveyed in June-August 2010. Your experiences may vary. Visit www.hino.com.

WWW.HINO.COM



HINOWATCH COVERAGE



A Toyota Group Company

2012MY 4 x 2 CONVENTIONAL HINO TRUCKS

HinoWatch is a 24/7/365 roadside assistance program that covers your new Hino truck for the first 3 years of ownership regardless of mileage. HinoWatch offers Hino owners roadside assistance throughout the United States and Canada.

Simply call the toll free number, 1-866-365-HINO (4466), and provide your Vehicle Identification Number (VIN), current truck location and problem description. All calls to HinoWatch are at no charge to Hino customers. A HinoWatch representative can assist customers in one of sixty-five languages and will help you with arrangements to get you back on the road quickly.

HINOWATCH COVERS THE FOLLOWING SERVICES AT NO-CHARGE TO THE CUSTOMERS.

LOCKOUT SERVICE

If you are locked out of your truck, HinoWatch will coordinate help to get you into your truck so you can get back on the road quickly.

BATTERY JUMPSTART

If your batteries are dead, HinoWatch will coordinate help with a jumpstart to get you back on the road quickly.

INFORMATION

Customers can call anytime for information such as the nearest authorized Hino dealer or simply to get answers to basic vehicle questions.

ADDITIONAL SERVICES HINOWATCH CAN COORDINATE FOR CUSTOMERS (CHARGES NOT COVERED BY HINOWATCH)

TOWING

HinoWatch will help owners arrange a tow truck if needed. If towing is required to an authorized Hino dealer due to a failure that is covered by Hino warranty, the customer will be reimbursed for the towing expense at the completion of the repairs through the dealer. If towing is not due to a warranty covered failure, the tow bill will be not be reimbursed to the customer.

ROADSIDE SERVICE

HinoWatch will assist the customer in arranging for roadside service assistance if requested. Expenses for roadside service assistance are not covered by HinoWatch or Hino warranty.

TIRE SERVICE

HinoWatch will assist the customer in arranging for roadside tire service if requested. HinoWatch will connect you to a local tire service provider that can assist you with roadside tire repairs.

OUT OF FUEL / DIESEL EXHAUST FLUID (DEF)

A HinoWatch vendor will arrive with fuel^{1,2} or DEF^{1,3} to get you on your way.

1. Customer is responsible for fuel, DEF, and roadside service costs. 2. 2005-2010 model year Hino trucks receive fuel and roadside service at no cost. 3. DEF only for use with 2011/2012 model year Hino trucks.



1807 N. Bloomington St.
 Streator, IL 61364
 Ph: 815-672-3211 or 800-443-0843
 Fax: 815-672-1490
sales@ustruckbody.com

Matheny Motor Truck Co.
 4125 1st Avenue
 Nitro ,WV 25143
jcumings@mathenymotors.com
 Attn: Jack Cummings
 Quantity: 1

Date: 1/30/2012
 Quote #: MD27898
 revised (2)
 Model: VA 24 96 96
 Phone: (304) 769 5860
 Fax:

ALUMINUM VAN BODY QUOTATION

LENGTH: 24' I.D. WIDTH: 96" O.D. HEIGHT: 96" I.D.

Construction:	(.040) Pre-painted white aluminum panels with high strength extruded aluminum (not steel) "Z" posts on 16" centers. Seven front wall posts (not five) for added strength and durability. Extruded aluminum front corner radius posts, (not roll formed) for maximum strength.
Roof:	(.060) translucent roof panel with anti-snag roof bows on 24" centers, "Zephyr" 12" fuel saving roof radius design with heavy-duty cast aluminum (not plastic) corner castings.
Rear Frame:	11 Ga. Galvaneal steel, internally and externally reinforced, and gusseted at all stress points, painted to match.
Side Door(s):	None.
Rear Door:	Standard plastic covered ¾" plywood roll up, 88"wide x 90.5" high clear opening. Stainless steel rivets and "E" coated hardware.
Rear:	Interlift ILP-33 tuck under liftgate, 3300 lb. capacity 80" x 48" aluminum platform, level ride operation, HD 2 step dock bumper with rubber blocks, cab cut off switch.
Grab Handle(s):	Curb side and road side on rear frame.
Rear Lighting:	Utilize OEM tail lights.
Floor:	1-1/8" high quality domestic laminated hardwood. 24" x 1/8" steel threshold plate at rear, with front edge routed into flooring.
Cross members:	3" steel I-Beam cross members on 12" centers with full steel wheel pan support over wheel area.
Interior Sides:	Sides - 3/8" full height premium plywood.
Interior Front:	Front - 1/2" full height premium plywood.
Interior Ties:	Sides - Two (2) row(s) recessed "E" Track @ ___ & ___" on center. Front - None.

MD27898 / PAGE 2

Scuff Plate:	Sides - 12" x 14 Ga. galvanized steel. Front - 12" x 14 Ga. galvanized steel extending below floor, welded to front understructure for maximum front wall strength.
Lights:	Interior - Two (2) dome light(s) with switch at rear, inside door on curbside. <i>Note: When switch is supplied by chassis OEM, dome light will be wired to factory switch in cab.</i> Exterior - per FMVSS - 108 with reflectors.
Undercoating:	Petroleum base undercoating applied, (not paint) full understructure.
Mounting:	Hardwood isolator with 5/8" zinc plated U-bolts installed through custom cut steel crush pipes between chassis frame. Structural steel channel anti-shift "side standards" welded to structural steel long sills. Complete factory mounting on drop shipped chassis with "U.S. Truck Body" or customer supplied mud flaps.
Understructure:	Unless noted below in ADDITIONAL FEATURES, this body is quoted and built for a single axle chassis. Tandem axle chassis require the <i>additional cost option</i> for our <i>Tandem Axle Reinforcement Package</i> .

Total Installed Price, F.O.B. Streator, IL: \$14,737.00

ADDITIONAL FEATURES INCLUDED IN THE ABOVE PRICING:

1. Four additional cross members at rear on 6" centers.
2. One Day Mount with liftgate.
3. Nose Cone installed.
4. 36" long x 18" high x 24" deep 11 Ga. steel tool box with locking handle installed under body on road side near front.

OPTIONS NOT INCLUDED IN THE ABOVE PRICING:

1. 102" O.D. body model: Add \$345.

TERMS: Net 20 Days. This quotation is firm for a 30 day period, subject to change without notification beyond 30 days. Any applicable state tax, or Federal Excise Tax on bodies mounted on chassis exceeding 33,000 lbs. GVW is not included and will be added as applicable. I have read and approve the above quotation and terms and indicated options that I want included into the base pricing. I authorize U.S. Truck Body to complete the above work at the price as illustrated. Note: Transportation charges when included herein for other than F.O.B. Streator, IL are subject to fluctuation up or down based upon the then current fuel surcharge in effect as applied by the carrier and will be adjusted accordingly due to fuel price volatility.

Customer Signature of Acceptance to Proceed With Order: _____
 Purchase Order #: _____ Date of Acceptance: _____
 E.T.A. of Chassis to Streator, IL: _____ Last Eight of V.I.N: _____
 Year / Make / Model of Chassis: _____
 Suspension Type (Circle One): Air Ride Spring Tire Size: _____
 Wheelbase: _____ Cab to Axle: _____

ILP PALLET PRO

2500 and 3300 lbs. Capacity

MBB PALFINGER

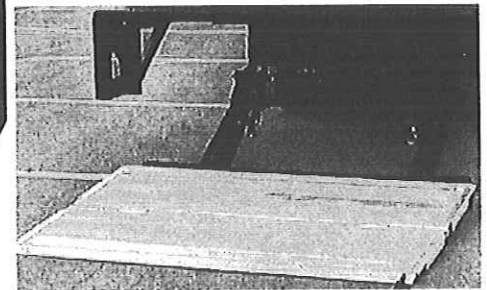
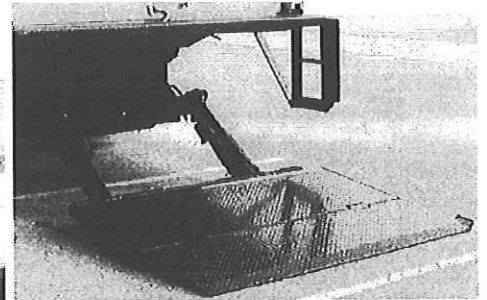
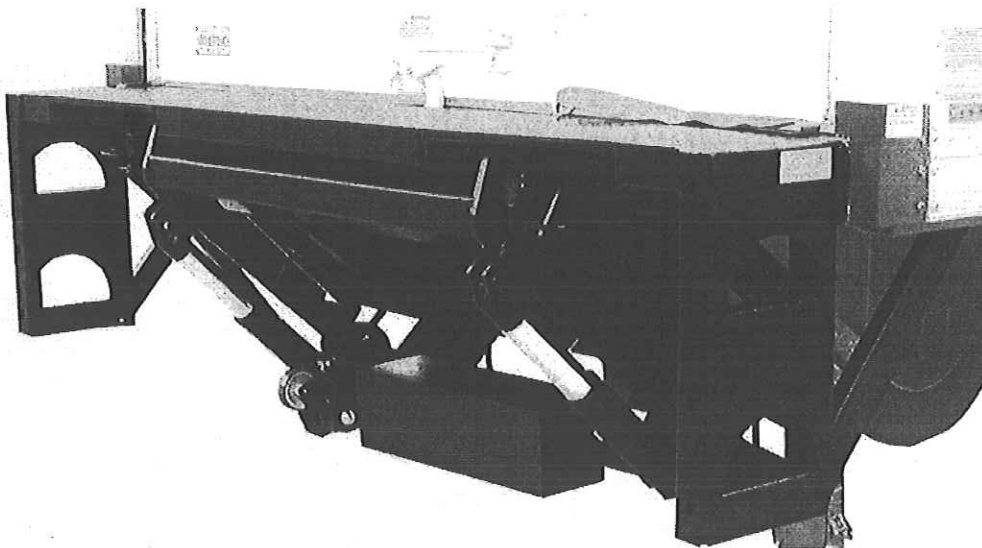

-OPTIMIZED-
FLEXIBILITY
DURABILITY
PROFITABILITY

The ILP Pallet Pro provides a lot of value for a small premium. Level ride platforms available in a variety of sizes from 48", 54", 60" x 80". Units are available in several steel and aluminum combinations.

LARGE Platform Lift! SMALL Platform Price!

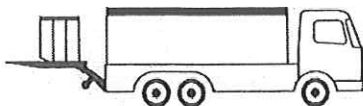

HEAVY DUTY CONSTRUCTION

- Bushings & zerks at all pivot points
- Heat treated pins
- Wide lift arm:
 - Provides added stability
 - Accepts a fixed hitch
- Thermo protected powerpack
- Increases life of components
- 150 AMP circuit breaker

BUILT IN STANDARD/ SAFETY FEATURES

- Dual cylinder stability
- Cab shut off switch
- Hydraulic cylinder locks on cylinder ports
- Adjustable roller and dual torsion assist offer minimum effort for platform folding
- Level ride platform
- Wide bed height range:
 - The 48" platform unit can be installed on as low as 38" laden bed height/up to 53" unladen

The MBB PALFINGER Pallet Pro, offering a platform size, level ride and lift capacity to handle many palletized or carted freight safely at a budget price.

MBB PALFINGER liftgates are pre-filled with aerospace hydraulic fluid. Our standard hydraulic cylinder lock provides added stability, better user control and improved safety.

The two cylinder mid arm design can accommodate a fixed receiver hitch. The platform rotates on an adjustable roller to adapt for different bed height installations.

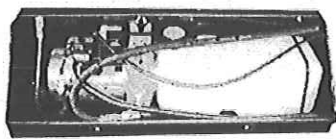

The thermo protected PowerPack is fully enclosed in a H/D powder coated steel box for protection and easy inspection. By using over sized quality components, we minimize maintenance and downtime.



The ILP incorporates our double torsions on both the main and folded section. The unique leveling joint on the ILP does not rotate on the ground. This makes the ILP an exceptionally smooth operating lift.

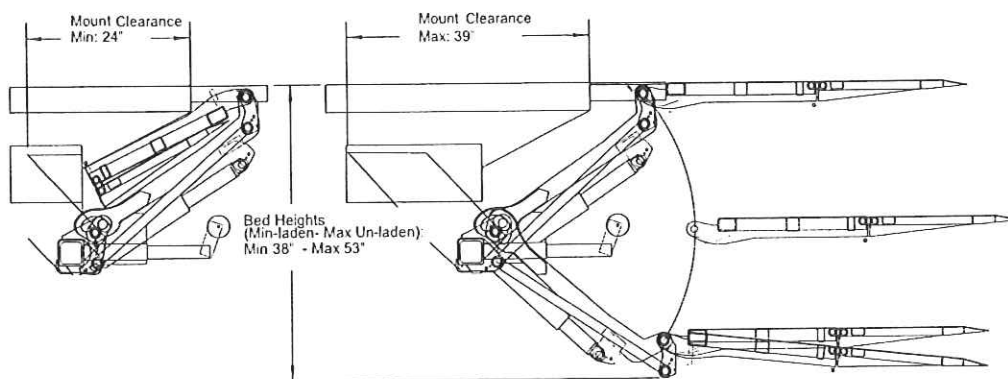

LIFTGATE OPTIONS:

- Auxiliary truck and trailer kits
- Dock bumpers
- Rubber pads
- Cart stops
- DOT rear impact guard
- Extra heavy duty trailer dock bumpers
- Hand held remote
- Aluminum tip sections
- All aluminum platforms
- Wireless remote
- 2" Receiver hitch

Model	Lifting Capacity (lbs)	Platform Length (inches)	Platform Width (inches)	Bed Height (inches)	Approx. Weight (lbs)	Mount Clearance (inches)
ILP 25	2500	48	80	38 - 53	750	21 - 30
ILP 33	3300	48	80	38 - 53	840	21 - 30
ILP 33	3300	54	80	45 - 55	900	24 - 34
ILP 33	3300	60	80	45 - 55	930	24 - 34

28 REASONS TO CHOOSE

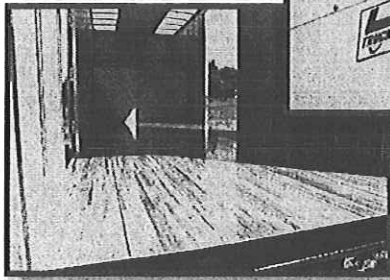
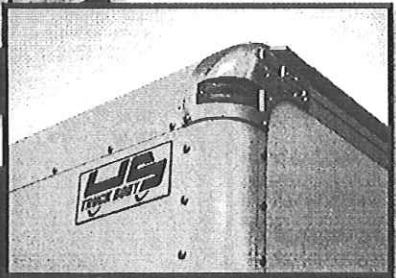
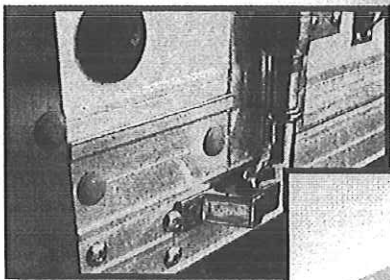

Since 1945, U.S. TRUCK BODY has been providing the transportation industry with high quality van bodies. There are many reasons to choose U.S. TRUCK BODY over our competition, but here we are going to present just 28. Let us show you how our bodies will add value to your operation. Give us a shot to quote your next van body purchase.

1-800-443-0843 • www.ustruckbody.com • sales@ustruckbody.com

WHY U.S. TRUCK BODY IS THE BEST IN CLASS VAN BODY BUILDER

1. Front corner radius is constructed of 1/8" aluminum extrusion (not roll formed).
2. Aluminum model has seven posts (not five) on front wall for maximum strength.
3. Shortest lead times in the industry.
4. Flooring is high quality domestic laminated hardwood (not pine or Malaysian).
5. Aluminum model has solid rivet spacing on 2.5" centers on every (not every other) seam.
6. Front corner castings are heavy duty aluminum (not plastic or composite) for longer life.
7. Decades and decades of experienced staff to assist with every van body specification and application.
8. DuraPlate panel (not plymetal) construction on all side and rear swing doors.
9. Fastest turn around on quotes in the industry.
10. Front wall scuff plate extends below floor welded to understructure.
11. Premium stainless steel (not zinc coated) bar lock hardware on rear swing doors.
12. Red and white LED lamps are standard with tail lights in rear frame option.
13. Dock bumpers are steel reinforced (not wood filled) with standard rubber bumpers.
14. Longitudinals are gusseted to every (not alternating) cross member.
15. Standard model roll up door has E coated hardware and stainless steel rivets.
16. Steel crush pipes installed on U bolts to prevent chassis frame damage.
17. Hardwood filler boards are steel banded to frame rails for no movement.
18. Front 10" roof radius designed for maximum air flow & fuel efficiency.
19. Tapered (not a trough) rear threshold prevents rot and water seepage from bumper.
20. Stainless steel rear frame is standard on all rear swing door equipped bodies.
21. Undercoating is heavy petroleum based (not just paint) on full understructure.
22. Exclusive underbody handles are standard equipment on all side doors.
23. Heavy duty extruded aluminum hinges on all swing doors.
24. Only stainless steel bolts, screws and aluminum fasteners used in construction.
25. All wiring is enclosed in plastic loom to protect against contact wear.
26. Pre-build available of some models pending chassis arrival.
27. No extra charge for translucent roof panel in lieu of aluminum panel.
28. Two 5/16" (not 1/4" or smaller) screws per board into flooring at every crossmember.

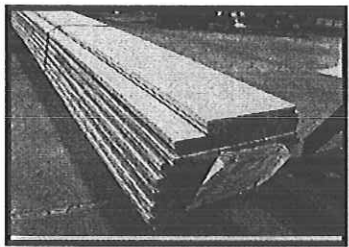
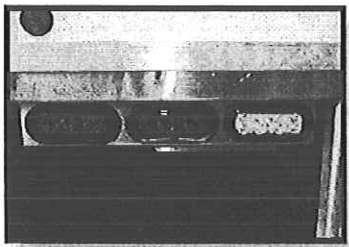
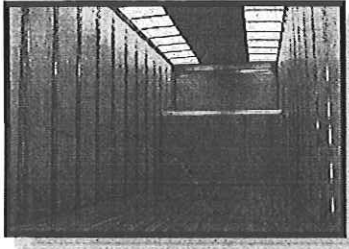

U.S. Truck Body • 1807 North Bloomington St. • Streator, IL 61364
Ph: 800-4430-0843 • 815-672-3211 • Fx: 815-672-1490
E-mail: sales@ustruckbody.com • Web: www.ustruckbody.com



U.S. TRUCK BODY 5-YEAR LIMITED WARRANTY

U.S. Truck Body warrants its FRP, aluminum and Freight Plate bodies, to the original purchaser, to be free from defects in material and workmanship for five (5) years from the date of delivery. Warranted for one year from date of delivery, are wood flooring, exterior paints and other finishes, wiring installation, caulking and protection against water leaks. Products and parts which are sold by U.S. Truck Body but not manufactured by U.S. Truck Body are not warranted by U.S. Truck Body, but are sold only with the warranties, if any, of the applicable manufacturer thereof. U.S. Truck Body hereby assigns to Purchasers, to the extent assignable, the applicable manufacturer's warranty for such products not manufactured by U.S. Truck Body. This Limited Warranty does not cover any problems that result from U.S. Truck Body bodies being subject to "Abnormal Usage". By "Abnormal Usage" U.S. Truck Body means that the body is used in the manner and for the purposes which the applicable body is not intended to be used. This Limited Warranty does not cover damage, without limitation, resulting from corrosive, hazardous or inherently unsafe cargo; or minor imperfections or defects which do not generally impair or affect the fair market value of the body or its suitability for its intended use; or damage or defects attributable to normal wear and usage.

Specifically excluded, without limitation are any and all warranties of merchantability and of fitness for a particular purpose. U.S. Truck Body shall not be liable for any amount in excess of the truck body purchase price, and in no event for special, indirect, consequential or incidental damages arising out of, or in connection with this warranty or the U.S. Truck Body bodies hereunder. No party shall make any repair under this warranty without the prior written consent of U.S. Truck Body. If U.S. Truck Body requests it, purchaser at its cost shall deliver the defective truck body to U.S. Truck Body or its designee for repairs.

Any claim under this warranty must be made within thirty (30) days from the date such claim should reasonably been discovered. Timeliness of notification being of the essence, Purchaser's late notification relieves U.S. Truck Body of all liability hereunder.

